

## TECHNICAL ASSISTANCE TO THE MANUFACTURE, CONSTRUCTION AND ASSEMBLY OIL PIPELINE FLOW PUMPS



1<sup>st</sup> Autor Name: Kellson Takenaka  
Position: Mechanical Engineer  
Company: Petrobras

Mr. Kellson works in machinery technical evaluation for more than 08 years. This experience includes vibration diagnostic and performance evaluation of pumps, compressors, steam turbines, gas turbines and gearboxes.



2<sup>nd</sup> Autor Name: Joilson S. Rangel Junior  
Position: Technical Consultant  
Company: Petrobras

Mr. Joilson works in machinery technical support on fabrication process, tests evaluation, construction and commissioning activities for more than 10 years. He received a Master Degree of Rotodynamic and Vibration from the Federal Univesity of Rio de Janeiro (UFRJ) on 2009.



3<sup>rd</sup> Autor Name: Edson Mesquita Marinho  
Position: Senior Mechanical Technician  
Company: Petrobras

Working in machinery maintenance, design and inspection for 40 years. This experience includes oil industry (onshore and offshore units). For 35 years, the professional had taught in one of the most prestigious school of mechanical technology in Brazil, in areas like material testing, hydraulic machines, pumping systems, maintenance and industrial lubricating.

### ABSTRACT

This paper reports the experiences acquired through the modifications and improvements implemented in the manufacture, construction and assembly of the oil flow centrifugal pumps. A Brazilian oil pipeline pumping capacity expansion, on Rio Grande do Sul – South Region of Brazil, was conceived aiming at refinery processing increase project from 20,000 m<sup>3</sup>/day to 30,000 m<sup>3</sup>/day, besides changing the product profile from processed product to national high viscosity national oils. Due to this reason, a new pump park and a new intermediate pump station have been erected. Thus, the oil received by a tanker and stored at the first pump park should be sending through a 97 km long and 560 mm diameter oil pipeline. In order to get such oil flow done, 03 new main pumps have been installed at the first pump park, one of them being a stand-by one, and other 03 pumps at second pump park, one of them being also a stand-by.

During the startup of news pumps, high vibration levels were observed in the rotors and in the equipment structures. The values defined by the manufacturer for equipment alarm and shutdown were, respectively, 50.0  $\mu\text{m}$  and 75.0  $\mu\text{m}$ , measured on the pump rotors in the bearing region. However, the global vibration levels of the pumps reached 110.0  $\mu\text{m}$  during the startup attended by the manufacturers. The equipment warranty period started after that, and a detailed activity planning was drawn up with the purpose of keeping the new pumps running at the lowest possible operational risk and avoiding a production reduction at Refinery. Simultaneously, various actions were taken in order to identify the vibration sources and reduce its intensity to the lowest possible values. After equipment modifications, median vibration values at 15.0  $\mu\text{m}$  were obtained. The logistics adopted in this process and the activities carried out to eliminate the causes of the high pump vibrations prevented an approximately

US\$ 25 million loss for the Customer and ensured an expressive increase in the equipment operational continuity reliability.

## INTRODUCTION

The refinery production capacity expansion project through the oil pipeline was divided into the modernization and pumping capacity increase of an existing pump park and creation of a new second pump park. The refinery was initially supplied with oil by the old pump park 20,000 m<sup>3</sup>/h flow-limited transfer pumps. With modernization and capacity expansion, it would be possible to send directly to refinery 24,000 m<sup>3</sup>/h oil averages. This step of the project should be concluded within approximately 06 months before the second pump park operation startup. With operating in series, the pumping capacity for the refinery would be expanded to 30,000 m<sup>3</sup>/h. This would meet the refinery's demand after its expansion.

## PROJECT CHARACTERISTICS

The centrifugal pumps applied to flow system are built according to BB1-type (Between Bearings) construction, as classified under the *American Petroleum Institute (API) 610 – 8<sup>th</sup> edition - Centrifugal Pumps for Petroleum, Heavy Duty Chemical, and Gas Industry Services* [1] Standard. Although being of the same model when compared to pumps made the twice pump park.

This equipment was designed by supplier and built to operate with diverse oil types, with densities ranging from 720.0 kg/m<sup>3</sup> to 940.0 kg/m<sup>3</sup> and viscosities ranging from 0.5 cP and 500.0 cP, according to refinery production programming.

The main pumps operate in series, at approximately 1950.0 m<sup>3</sup>/h flows for light oil and 1350.0 m<sup>3</sup>/m for heavy oil. The discharge pressure at the first park pumps is 50.0 kgf/cm<sup>2</sup>. After running 45.0 km through the oil pipeline, the product reaches the second park pumps at 6.0 kgf/cm<sup>2</sup>. In the second pump park, the oil is re-pumped to Refinery, and once more expelled through the pump discharge at 50.0 kgf/cm<sup>2</sup>.

These pumps were the first equipment purchased by the Customer for this service to operate with an impeller radial double-outlet design. This change was implemented by the manufacturer as an improvement in this centrifugal pump model building process (Figure 1).

The pumps park concept of remote operation aided by a continuous monitoring system of the vibrations and temperatures on the equipment's bearings is another important characteristic of this design. The system's remote operation is carried out by the National Operational Control Center (*Centro Nacional de Controle Operacional - CNCO*), in Rio de Janeiro – Southeast Region of Brazil, without any local

attendance, thus configuring a completely unattended operation. For this reason, the data supervision, control and acquisition system is extremely important to the equipment's operational availability.

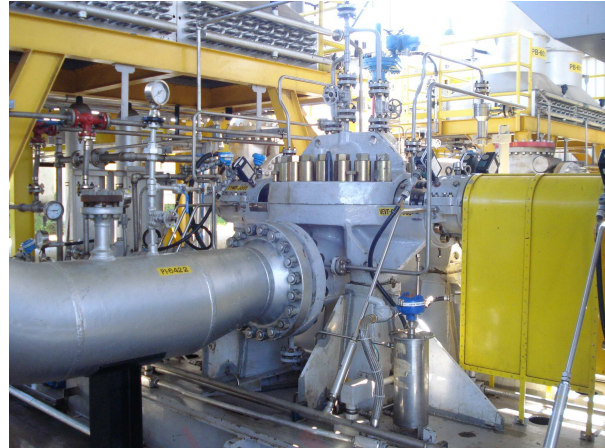

Figure 1: Oil pipeline pump

## DYNAMIC INSTABILITY CHARACTERISTIC

Since their startup, pumps have presented high vibration levels, reaching global values of up to 110.0  $\mu\text{m}$ , whose amplitude varied according to the pumped oil density. The manufacturing standard [1] defines 30.0  $\mu\text{m}$  as the maximum global vibration value obtained during the pump tests at the manufacturer's facilities as measured on the pump rotors in the bearing area. The values defined by the manufacturer for equipment alarm and shutdown were, respectively, 50.0  $\mu\text{m}$  and 75.0  $\mu\text{m}$ . Therefore, the operation of the equipment in field started in extreme operational status, with high risks of mechanical failure and, consequently, refinery supply shortage.

In equipment running with hydrodynamic bearings, which sustaining pressure is created by the relative displacement between the shaft and the oil film, monitoring becomes necessary through displacement sensors (proximeters). Proximeters are inductive sensors sensitive to the corresponding electromagnetic camp variation. For the correct identification of the shaft position in relation to the bearing and the reliable measurement of the shaft displacement values (radially measured), it is necessary to utilize 02 sensors assembled with a 90° spacing between them, as shown in Figures 2 and 3.

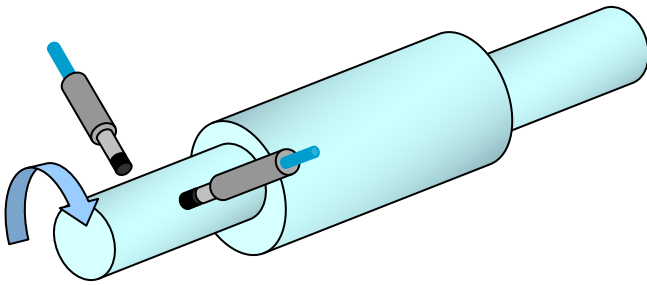

Figure 2: Sensors positioning schematic illustration

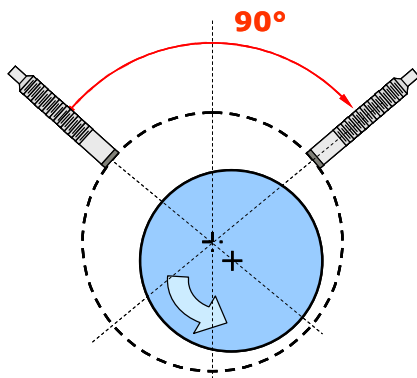

Figure 3: Proximeter assembly angle

Through the vibration analysis, obtained by the utilization of proximeters in this project, a great variation of the vibration amplitude with low frequencies excitations was verified, including the measurement in the time domain (temporal), confirming the values presented by the supervision. Such variation indicated bearing axis instability.

### PROBABLE CAUSES FOR THE DYNAMIC INSTABILITY

After the dynamic monitoring, the probable following causes were indicated:

- Fluid turbulent flow at the impeller's inlet caused by the piping design configuration;
- Typical metal base frequency very close to the pump's operational frequency;
- Impeller's hydraulic unbalance;
- Rotor misalignment due to casing casting and/or machining deviations;
- Excessive bearing clearance.

### DIFFICULTIES FOUND

Among the difficulties found in the investigation process of the problem root cause, we can mention:

- The first pumps already in field and operating in highly unfavorable dynamic conditions;
- The second pumps already built, in plant-test phase and, originally manufactured in the same way as problems pumps;
- Planning for intervention in pumps operating at the first pump park, depending on short low-demand periods in Refinery processing schedule;
- Interface with manufacturer;

### LOGISTIC SCHEDULE

In face of the difficulties found, the following activities schedule was established:

- Three pumps would return, one by one, to the manufacturer's premises for re-work, without, however, interrupting pumping to Refinery. Thus, the terminal would start to operate during a determined period without a standby equipment;
- Three other pumps would be kept at the manufacturer's premises for re-work;
- The pump delivery term should not change the work construction timeline;
- All the changes to be implemented in the equipment would depend on Customer approval/knowledge;
- All the modifications carried out, transport, subcontracting, etc. should be performed without onus to Customer.

### PROPOSED ALTERNATIVES

With the in-plant equipment disassembly and Customer reasonable supervision, other failures were identified in the equipment that could be contributing to the high vibration levels under operation. Therefore, new guidelines were established to eliminate the problem:

- Replacement of the impellers for parts melted in ceramic molds;
- Verification of the impeller and rotating assembly's dynamic balance;
- Superficial finish suitability (run out) in the vibration sensors' operating region;
- Replacement of the bearings that presented excessive clearance;
- Modification of the forced-lubrication pump coupling sleeve;
- Verification of the melted casings' manufacturing dimensional clearances and tolerances;
- In-plant mechanical operation and performance testing, in plant, as per in-field pipeline layout.

## CRITICAL ANALYSIS OF PROPOSED ALTERNATIVES

### Impeller replacement

The replacement of the impellers originally melted in sand mold for components melted in ceramic molds aimed at eliminating the maximum of dimensional deviations (of approximately 20%) in the impeller fluid exit areas. A greater dimensional uniformity in this region provides a better radial distribution of pressure and, consequently, a greater rotor hydraulic balance.



Figure 4: Impeller detail

### Rotating Assembly Balance

During the verification of the pump impellers' residual balance level according to ISO 1940 [2], the execution procedure was found not to be a guarantee of satisfactory results repeatability. The impeller's fixing mode in the balancing machine, through a conic device, did not present enough centralization and hardness.

Another deviation observed was the non utilization of the wear rings during the individual balance process of the impellers. In addition, the bearing box deflector rings were not assembled during the complete rotating assembly balance either.

After the changes implemented by supplier in the device and in the balancing execution procedure, substantial improvement was achieved on the rotating assembly balancing repeatability and final values.

### Superficial finish on sensors area

With the rotor disassembly, it was evidenced that the manufacturer has not carried out the effective control of the shaft's run-out in the proximeter operating region (Figure 5).

According to the manufacturing standard applied to the specification for combined electric and mechanical run-out, it shall not exceed 25% of the maximum allowed peak-to-peak vibration amplitude, or  $12.0\ \mu\text{m}$ , which happens to be the lowest.

The mechanical run-out reduction in the vibration sensor region was carried out through

burnishing. After this operation, the values reached in all shafts were under  $9.0\ \mu\text{m}$ .

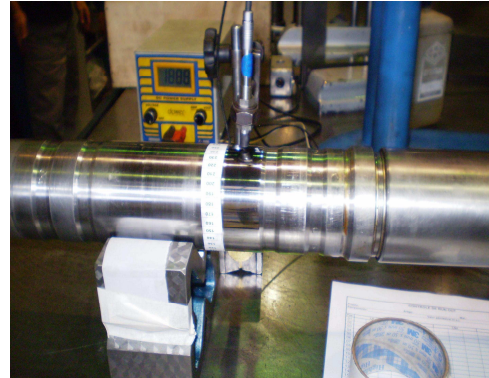

Figure 5: Shaft run-out verification

### Sliding-bearing clearance suitability

No measurement record of the assembly clearances of the original bearings' bushings was found. After their dimensional inspection, it was observed the use of bearings with diameters close to or superior to the design maximum values.

Bearing bushings were changed and further dimensional control was carried out by third qualified inspector, in order to guarantee the assembly tolerances.

The sliding bearings used are of four segments type, that is, they have four (04) lobules in the bearing perimeter in order to form an oil wedge. This building characteristic provides the material with high hardness and damping, when it works within the assembly allowed clearances.

### Main pump coupling sleeve modification

The forced-lubrication main pump coupling sleeve design (Figures 6 and 7), manufacturing and assembly were changed with the purpose of eliminating the vibration induced to the oil transfer pump shaft in the bearing region on the opposite side to the coupling (LOA).

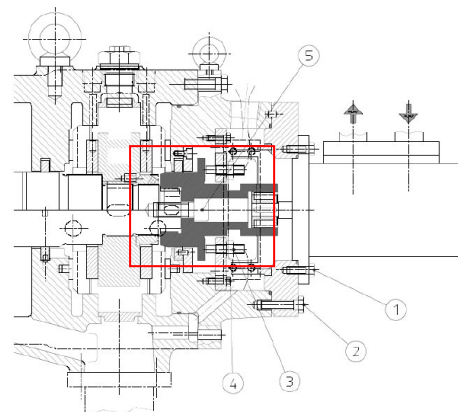

Figure 6: Forced-lubrication pump fixing sleeve detail



Figure 7: Original sleeve

The main changes implemented in the coupling sleeve were the following:

- Sleeve fixation onto the main shaft, through 180° out-of-phase and round-profiled pins in order to mitigate the effects of possible misalignments with the main pump shaft (figure 8);
- Alteration of the diameter of the bolt which fixes the sleeve onto the main shaft from M12 to M16, in order to ensure the 0.05mm maximum stipulated beat, and, consequently, the assembly repeatability (figure 8);
- Superficial sleeve hardness increase through nitriding, in order to eliminate possible distortion effects of the coupling sleeve during operation (figure 8);

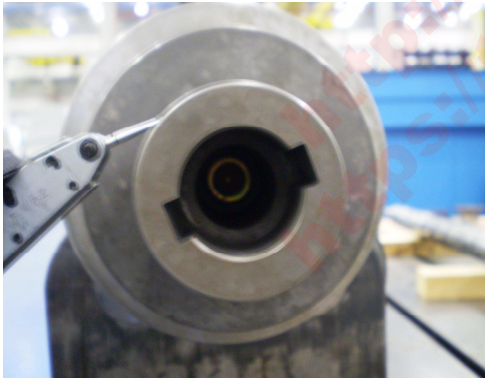

Figure 8: Modified sleeve

#### **Verification of the melted casing manufacturing clearances and dimensional tolerances**

A dimensional inspection was carried out in all melted casings under ASTM A216 WCB [3]. Such three-dimensional measurements were carried out with the casings opened and closed aiming at verifying the clearances, flatness, perpendicularity, circularity and parallelism of the following regions:

- Bearing box setting face;
- Mechanical seal setting face;
- Stationary wear rings setting face.

Although no considerable wear was found that would cause discard of parts, the measurements carried out with closed casings proved to be more effective and reliable, therefore the manufacturer's procedure was recommended.

#### **Mechanical Performance and Operation Testing on the testing bench**

After the implementation of all the changes and improvements, the pumps were assembled on the manufacturer's bench to be tested as to mechanical performance and operation. Customer requested that all the tests were carried out attempting to simulate as much as possible the in-field operational conditions. Therefore, the manufacturer should use the following equipment for the test:

- Pipelines of the same field diameter in order to simulate the flow speed influence;
- Field pipeline lay out with a turn placed 1.0 meter away from the suction, in order to verify the turbulent flow influence, as per Figure 09;
- Forced-lubrication main pump assembled and pressurized in closed circuit to simulate the dynamic efforts induced in the shaft end.

During tests, the following parameters were monitored:

- Bearing mechanical vibration;
- Shaft mechanical vibration;
- Bearing external temperature;
- Oil temperature;
- Noise level;
- Manometric height x flow;
- Efficiency x flow
- Consumed power x flow;
- NPSH x flow

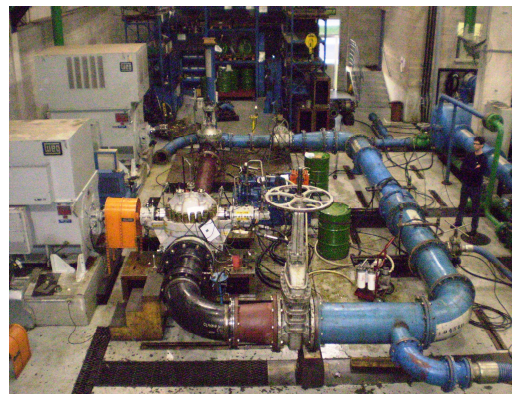

Figure 9: Layout for performance testing

Test showed that, after the implementation of all changes and improvements, the evaluated points presented pretty satisfactory results when compared to those recommended by the manufacturing standard [1].

### Commissioning

While the modifications and improvements were being implemented in the stand-by pump, Refinery kept being supplied by the twice pumps in extreme vibration conditions. Due to this situation, some pumping units' components were damaged, such as sensors, transmitters, indicators, etc. The operational continuity of the O2 unit was only possible due to the possibility of immediate removal of these components from the idle facilities.

With the activities end of in-plant activities, the pumps were assembled and commissioned at the respective terminals. For the commissioning of the Second Pump Park, a sequence of individual field tests was defined. If each one of them presented satisfactory dynamic condition, the next step would be the test together with the main pumps.

After the commissioning of the first two pumps the presented mechanical results were very satisfactory. The mechanical vibration values were below 18.0  $\mu\text{m}$ , with 50.0  $\mu\text{m}$  being an alarm level. During these individual tests, the pumps operated at 1200.0  $\text{m}^3/\text{h}$ , close to the minimal flow and out of the equipment operation preferred region.

As expected, the pumps working in series with the pumps of the Second Pump Park at the design flow (1950.0  $\text{m}^3/\text{h}$ ) presented an even better dynamic condition and vibration values below 12.0  $\mu\text{m}$ . The temperature values are found constant and within the manufacturing standard [1] accepted limits throughout the whole commissioning.

### CONCLUSIONS

The technical appraisals and the logistic planning carried out in this specialized assistance increased the reliability and operational continuity of the units and avoided a high loss to the Customer.

If the new park oil pumps were not kept in operation, it would require approximately 10 days to resume the old system's operation, which would reduce the refinery production in this period from 20,000  $\text{m}^3/\text{day}$  to 17,000  $\text{m}^3/\text{day}$ , with the gradual consumption of its inventory of approximately 200,000  $\text{m}^3$ . It would represent an invoicing fall to refinery, besides an additional cost of oil tanker's demurrage, which, together, would reach U\$ 4.5 million. If we consider that the new park Oil Pumps would have a 24,000  $\text{m}^3/\text{day}$  pumping capacity, the resumption of the old system would accordingly result in a 4,000  $\text{m}^3/\text{day}$  reduction in the expected oil flow capacity to Refinery. Further assuming that 180 days were required for the equipment removal and reinstallation after the implementation of all modifications and improvements, this would result in an invoicing fall of around U\$ 20 million.

The whole equipment is currently operating with vibration levels lower than 20.0  $\mu\text{m}$ , and the manufacturer's initial recommendations as to equipment's alarm and shut down levels respectively equal to 50.0  $\mu\text{m}$  and 75.0  $\mu\text{m}$  were kept. These measures caused a significant increase in the equipment operational continuity and reliability.

### REFERENCES

- [1] Centrifugal Pumps for Petroleum, Heavy Duty Chemical, and Gas Industry Services - American Petroleum Institute Standard – 610 - eighth edition
- [2] Mechanical Vibration – Balance Quality requirements for rotor in constant (rigid) state – ISO 1940 – 1:2003
- [3] Industrial Pumps – 2<sup>nd</sup> edition Falco, Reinaldo de
- [4] Equipamentos Mecânicos – Análise de Falhas e Solução de Problemas – Luiz Otavio Affonso
- [5] Desempenho de Turbomáquinas no Campo – Guilherme Leibsohn Martins