

SCALE 1 : 10

UNLESS OTHERWISE SPECIFIED: DIMENSIONS ARE IN MILLIMETERS SURFACE FINISH: TOLERANCES: LINEAR: ANGULAR:			FINISH:	DEBUR AND BREAK SHARP EDGES	DO NOT SCALE DRAWING	REVISION	
					تیم مکترونیک دانشگاه آزاد		
					پروژه غلطک ورق گالوانیزه		
DRAWN			TITLE:			Assem1	
CHK'D			DWG NO.				A4
APPV'D			SCALE:1:20				SHEET 1 OF 9
MFG			WEIGHT:				
Q.A			MATERIAL:				

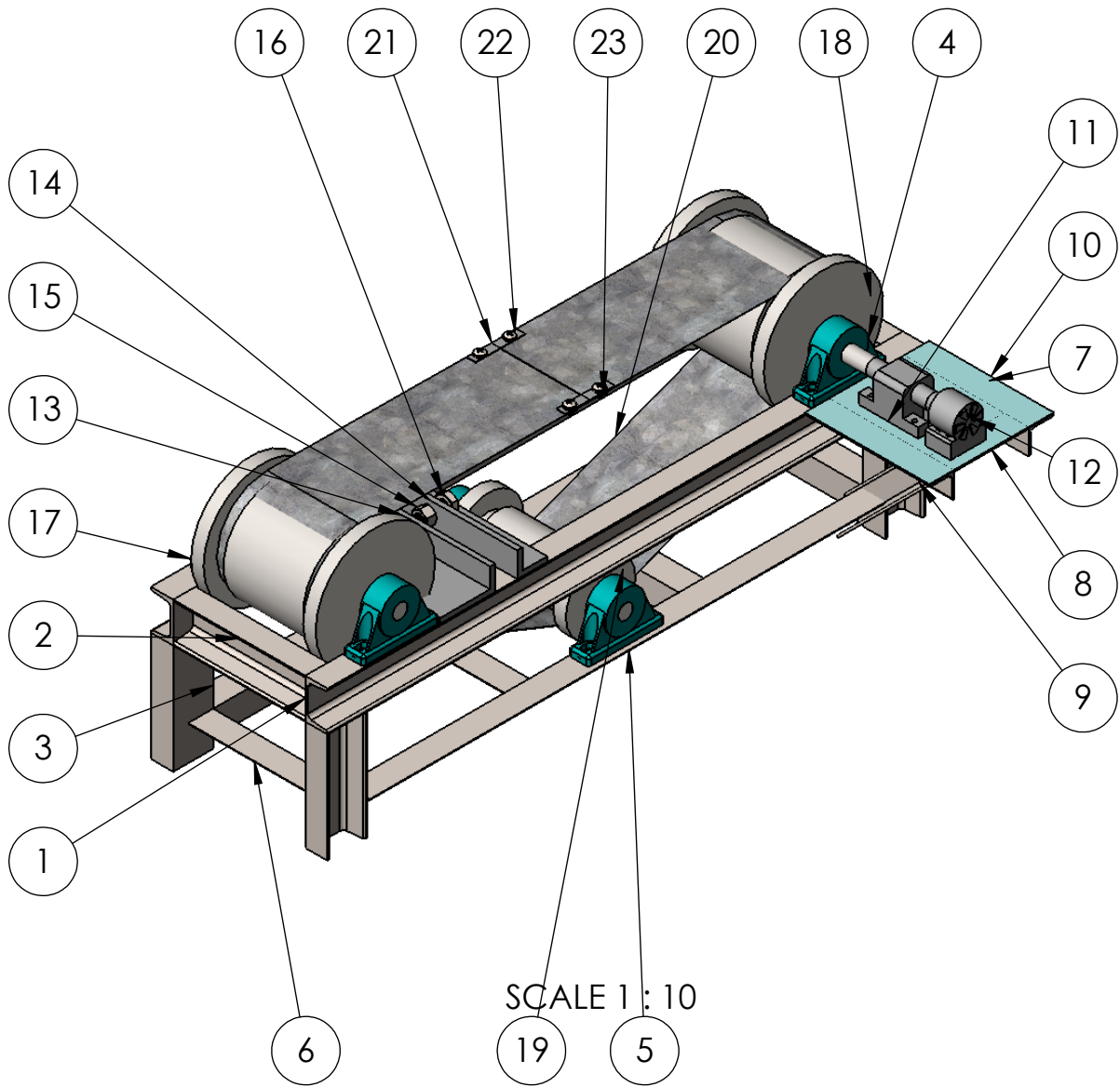

UNLESS OTHERWISE SPECIFIED:
 DIMENSIONS ARE IN MILLIMETERS
 SURFACE FINISH:
 TOLERANCES:
 LINEAR:
 ANGULAR:

FINISH:

DEBUR AND
 BREAK SHARP
 EDGES

DO NOT SCALE DRAWING

REVISION

	NAME	SIGNATURE	DATE		
DRAWN					
CHK'D					
APPV'D					
MFG					
Q.A				MATERIAL:	
				WEIGHT:	

TITLE:	
DWG NO.	Assem1
SCALE:1:20	A4
SHEET 2 OF 9	

ITEM NO.	PART NUMBER	DESCRIPTION	QTY.
1	CH 80 x 8x1200		2
2	CH 80 x 8x265		2
3	CH 80 x 8x220		4
4	block bearing		6
5	50x50x4x1040		2
6	50x50x4x265		4
7	50x50x4x250		2
8	50x50x4x150		1
9	50x50x4x353		1
10	motor base plate		1
11	gear reducer		1
12	motor		1
13	jack1		1
14	jack2		1
15	Hexagon Nut ISO - 4034 - M20 - S		1
16	ISO 7411 - M20 x 75 --- 75-WS		1
17	drum31		1
18	drum32		1
19	drum33		1
20	rolled plate3		1
21	bolt plate		2
22	ISO 7045 - M10 x 12 - Z --- 12S		4
23	Square nut DIN 562 M10 - SW16 -S		4

UNLESS OTHERWISE SPECIFIED: DIMENSIONS ARE IN MILLIMETERS SURFACE FINISH: TOLERANCES: LINEAR: ANGULAR:		FINISH:	DEBUR AND BREAK SHARP EDGES	DO NOT SCALE DRAWING	REVISION
NAME	SIGNATURE	DATE		TITLE:	
DRAWN					
CHK'D					
APPV'D					
MFG					
Q.A			MATERIAL:	DWG NO.	Assem1
					A4
			WEIGHT:	SCALE:1:20	SHEET 3 OF 9

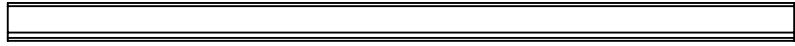
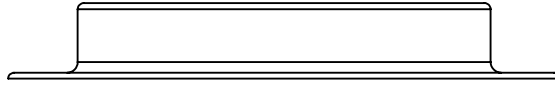
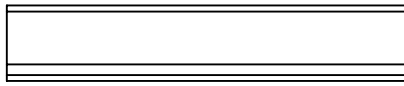
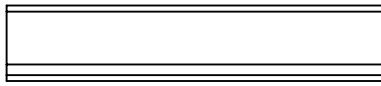
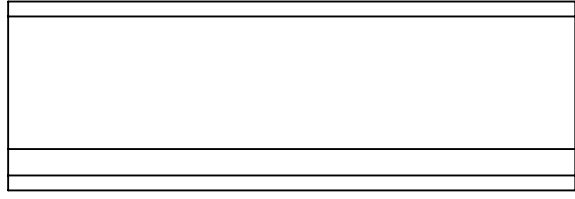
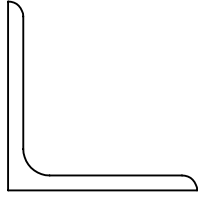

UNLESS OTHERWISE SPECIFIED:
 DIMENSIONS ARE IN MILLIMETERS
 SURFACE FINISH:
 TOLERANCES:
 LINEAR:
 ANGULAR:

FINISH:

DEBUR AND
 BREAK SHARP
 EDGES

DO NOT SCALE DRAWING

REVISION

	NAME	SIGNATURE	DATE			
DRAWN						
CHK'D						
APPV'D						
MFG						
Q.A						
					MATERIAL:	
					WEIGHT:	

TITLE:	
DWG NO.	Assem1
SCALE:1:2	A4
SHEET 4 OF 9	

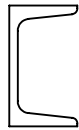
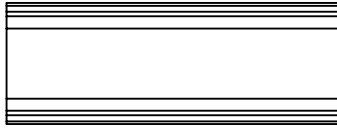
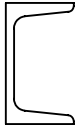

UNLESS OTHERWISE SPECIFIED:
 DIMENSIONS ARE IN MILLIMETERS
 SURFACE FINISH:
 TOLERANCES:
 LINEAR:
 ANGULAR:

FINISH:

DEBUR AND
 BREAK SHARP
 EDGES

DO NOT SCALE DRAWING

REVISION

	NAME	SIGNATURE	DATE		
DRAWN					
CHK'D					
APPV'D					
MFG					
Q.A				MATERIAL:	
				WEIGHT:	

TITLE:	
DWG NO.	Assem1
A4	
SCALE:1:5	SHEET 5 OF 9

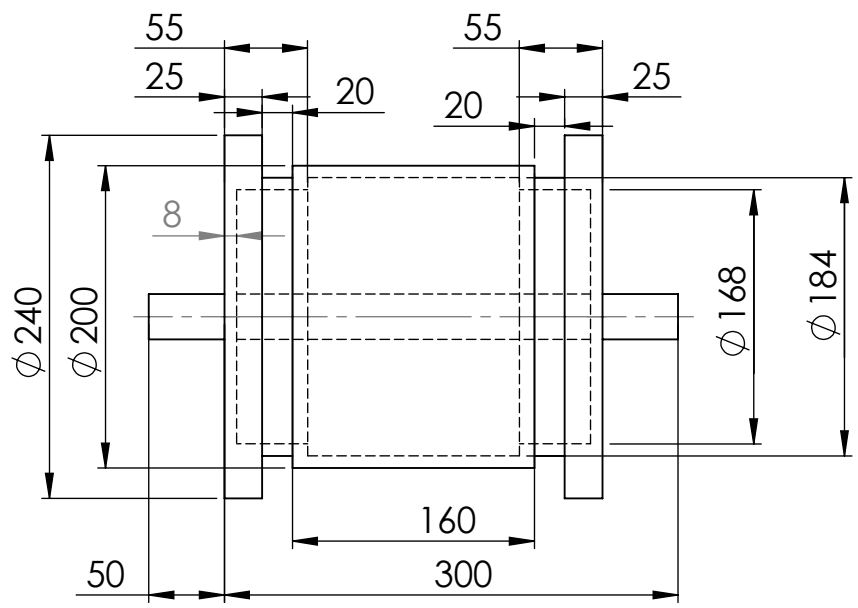
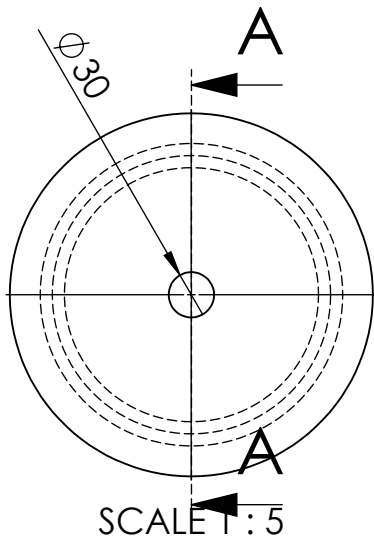

SCALE 1 : 5

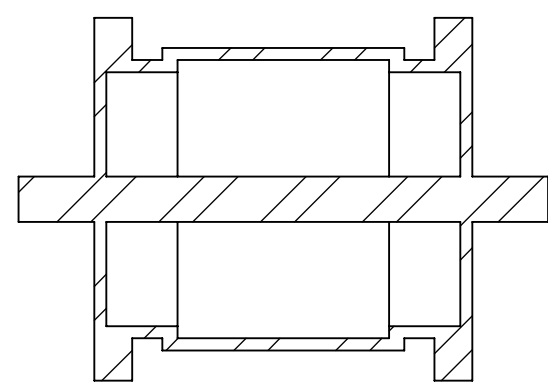
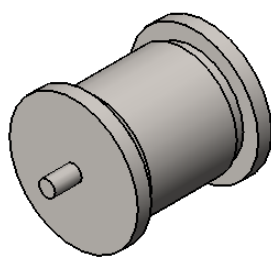

SECTION A-A

SCALE 1 : 5

Density = 0.007800 grams per cubic millimeter

Mass = 21698.323237 grams

UNLESS OTHERWISE SPECIFIED: DIMENSIONS ARE IN MILLIMETERS SURFACE FINISH: TOLERANCES: LINEAR: ANGULAR:				FINISH:		DEBUR AND BREAK SHARP EDGES		DO NOT SCALE DRAWING		REVISION	
DRAWN				SIGNATURE		DATE		TITLE:			
CHK'D											
APPV'D											
MFG											
Q.A.						MATERIAL:		DWG NO.		Assem1	
								SCALE:1:10		SHEET 6 OF 9	
										A4	

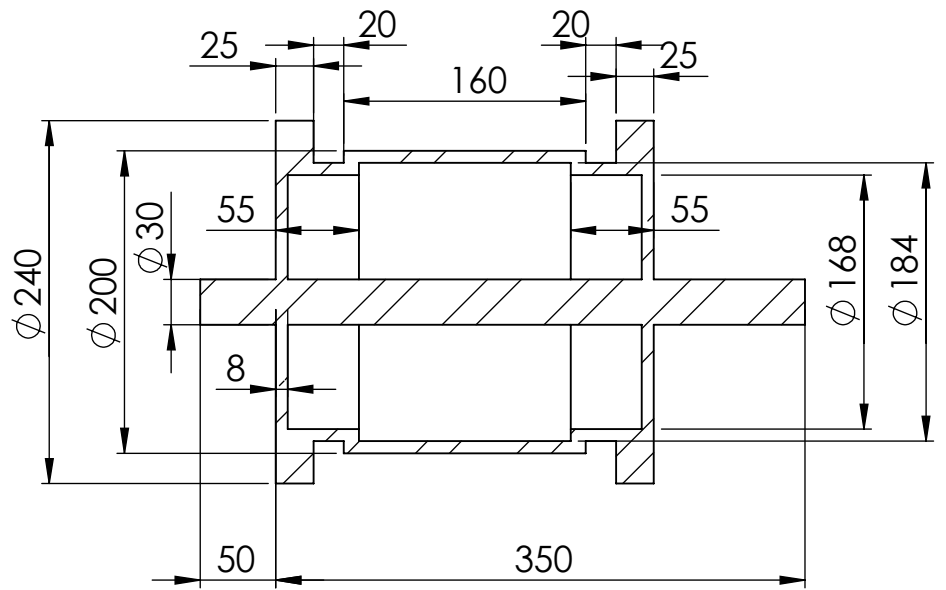
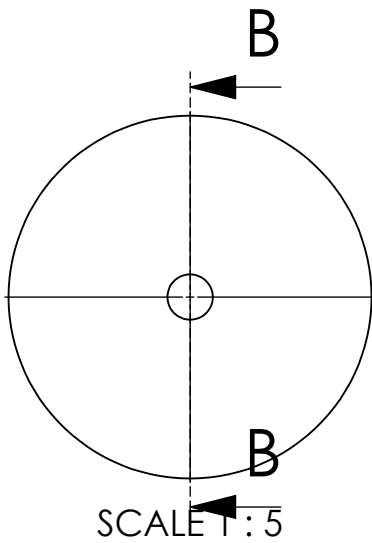

SECTION B-B

SCALE 1 : 5

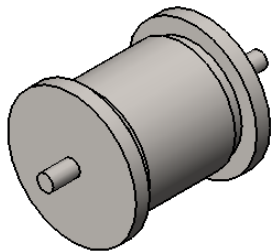

Density = 0.01 grams per cubic millimeter

Mass = 21974.00 grams

UNLESS OTHERWISE SPECIFIED: DIMENSIONS ARE IN MILLIMETERS SURFACE FINISH: TOLERANCES: LINEAR: ANGULAR:			FINISH:			DEBUR AND BREAK SHARP EDGES			DO NOT SCALE DRAWING			REVISION		
DRAWN			SIGNATURE			DATE			TITLE:					
CHK'D														
APPV'D														
MFG														
Q.A.						MATERIAL:			DWG NO.			Assem1		
												A4		
						WEIGHT:			SCALE:1:10			SHEET 7 OF 9		

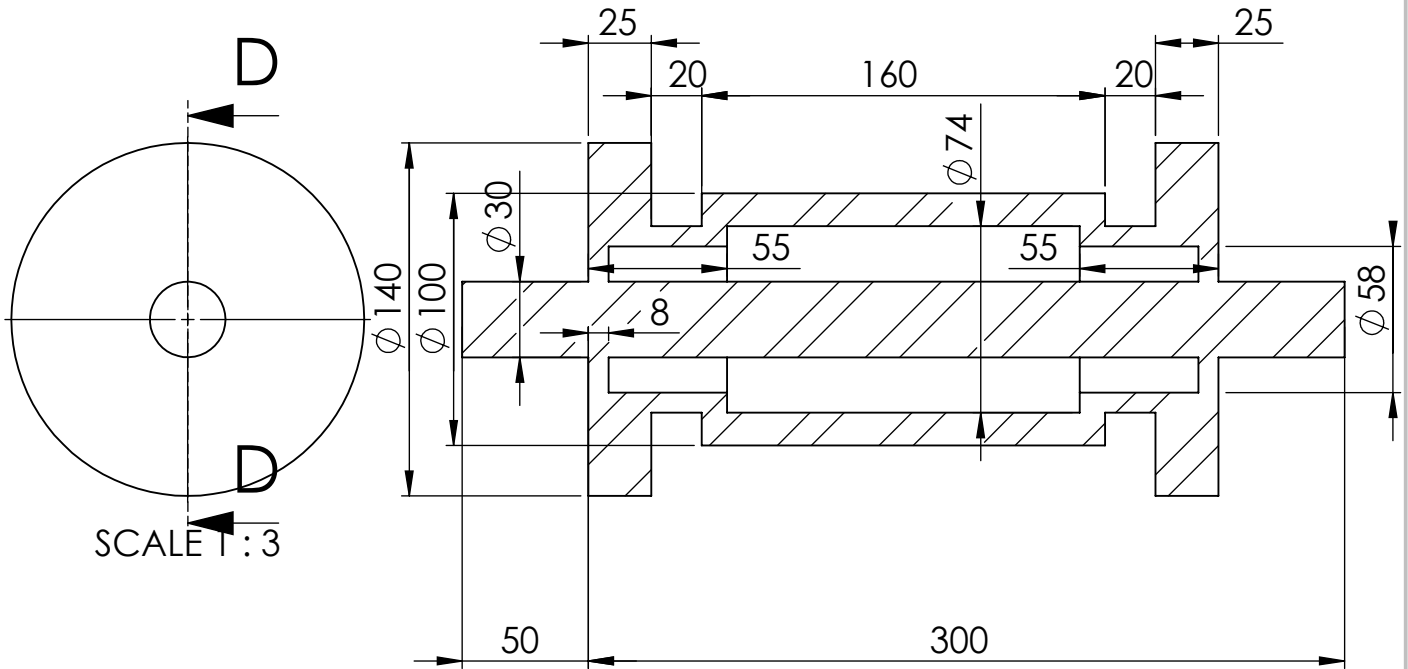

SECTION D-D

SCALE 1 : 3

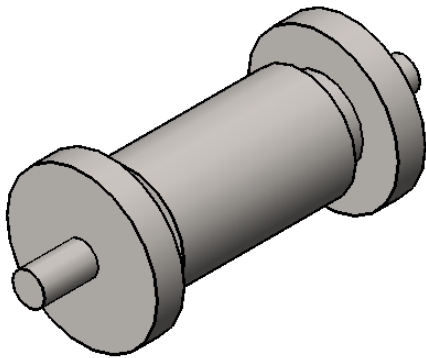

Density = 0.007800 grams per cubic millimeter

Mass = 12355.031907 grams

UNLESS OTHERWISE SPECIFIED: DIMENSIONS ARE IN MILLIMETERS SURFACE FINISH: TOLERANCES: LINEAR: ANGULAR:				FINISH:		DEBUR AND BREAK SHARP EDGES		DO NOT SCALE DRAWING		REVISION	
DRAWN				SIGNATURE		DATE		TITLE:			
CHK'D											
APPV'D											
MFG											
Q.A.						MATERIAL:		DWG NO.		Assem1	
								SCALE:1:5		A4	
						WEIGHT:		SHEET 8 OF 9			

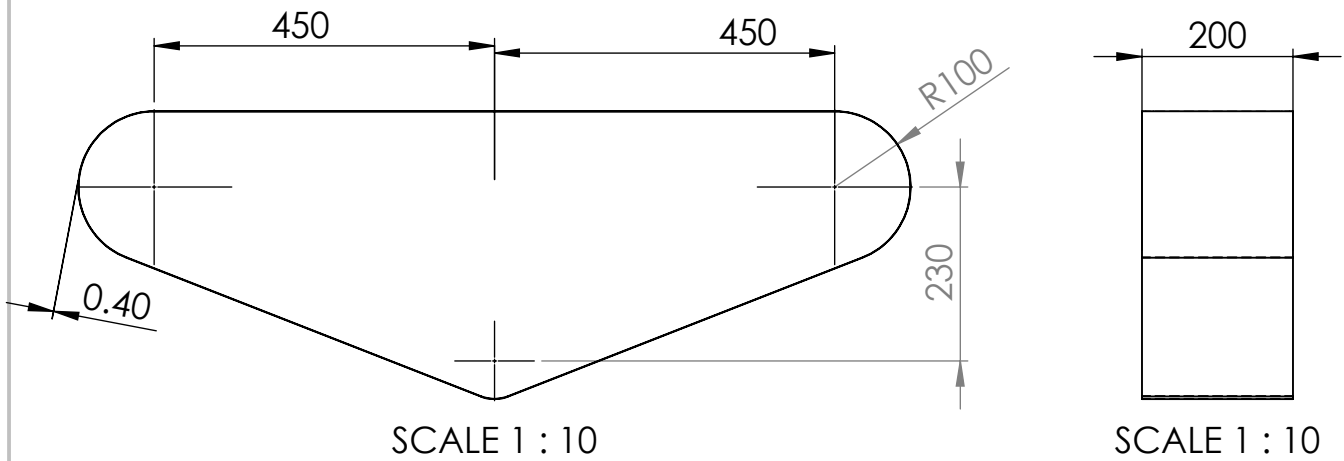

Galvanized steel

Density = 0.007870 grams per cubic millimeter

Mass = 1571.133989 grams

Total Length: 2495.76mm
rolled plate3.SLDPRT

UNLESS OTHERWISE SPECIFIED: DIMENSIONS ARE IN MILLIMETERS SURFACE FINISH: TOLERANCES: LINEAR: ANGULAR:				FINISH:		DEBUR AND BREAK SHARP EDGES		DO NOT SCALE DRAWING		REVISION	
DRAWN				SIGNATURE		DATE		TITLE:			
CHK'D											
APPV'D											
MFG											
Q.A						MATERIAL:		DWG NO.		Assem1	
										A4	
						WEIGHT:		SCALE:1:20		SHEET 9 OF 9	