

MICHAEL LAI ERHARD KREMPLE DAVID RUBEN

INTRODUCTION TO
CONTINUUM
MECHANICS



FOURTH EDITION

Introduction to Continuum Mechanics

Fourth Edition

This page intentionally left blank

Introduction to Continuum Mechanics

Fourth Edition

W. Michael Lai

Professor Emeritus of Mechanical Engineering and Orthopedic Bioengineering
Columbia University, New York, NY, USA

David Rubin

Senior Scientist
Weidlinger Associates, Inc., New York, NY, USA

Erhard Krempf

Professor Emeritus of Mechanical Engineering
Rensselaer Polytechnic Institute, Troy, NY, USA



AMSTERDAM • BOSTON • HEIDELBERG • LONDON
NEW YORK • OXFORD • PARIS • SAN DIEGO
SAN FRANCISCO • SINGAPORE • SYDNEY • TOKYO
Butterworth-Heinemann is an imprint of Elsevier



Butterworth-Heinemann is an imprint of Elsevier
30 Corporate Drive, Suite 400, Burlington, MA 01803, USA
Linacre House, Jordan Hill, Oxford OX2 8DP, UK

Copyright © 2010, Elsevier Inc. All rights reserved.

No part of this publication may be reproduced, stored in a retrieval system, or transmitted in any form or by any means, electronic, mechanical, photocopying, recording, or otherwise, without the prior written permission of the publisher.

Permissions may be sought directly from Elsevier's Science & Technology Rights Department in Oxford, UK: phone: (+44) 1865 843830, fax: (+44) 1865 853333, email: permissions@elsevier.com. You may also complete your request online via the Elsevier homepage (<http://www.elsevier.com>), by selecting "Support & Contact" then "Copyright and Permission" and then "Obtaining Permissions."

Library of Congress Cataloging-in-Publication Data

Application submitted

British Library Cataloguing-in-Publication Data

A catalogue record for this book is available from the British Library.

ISBN: 978-0-7506-8560-3

For information on all Butterworth-Heinemann publications,
visit our web site at: www.elsevierdirect.com

Printed in the United States of America

09 10 11 12 13 10 9 8 7 6 5 4 3 2 1

Working together to grow
libraries in developing countries

www.elsevier.com | www.bookaid.org | www.sabre.org

ELSEVIER

BOOK AID
International

Sabre Foundation

Table of Contents

Preface to the Fourth Edition.....	xiii
Chapter 1 Introduction.....	1
1.1 Introduction	1
1.2 What Is Continuum Mechanics?	1
Chapter 2 Tensors.....	3
Part A: Indicjal Notation.....	3
2.1 Summation Convention, Dummy Indices	3
2.2 Free Indices	4
2.3 The Kronecker Delta.....	5
2.4 The Permutation Symbol	6
2.5 Indicjal Notation Manipulations	7
Problems for Part A	8
Part B: Tensors.....	9
2.6 Tensor: A Linear Transformation.....	9
2.7 Components of a Tensor.....	11
2.8 Components of a Transformed Vector	14
2.9 Sum of Tensors	16
2.10 Product of Two Tensors	16
2.11 Transpose of a Tensor	18
2.12 Dyadic Product of Vectors	19
2.13 Trace of a Tensor.....	20
2.14 Identity Tensor and Tensor Inverse.....	20
2.15 Orthogonal Tensors.....	22
2.16 Transformation Matrix Between Two Rectangular Cartesian Coordinate Systems.....	24
2.17 Transformation Law for Cartesian Components of a Vector.....	26
2.18 Transformation Law for Cartesian Components of a Tensor	27
2.19 Defining Tensor by Transformation Laws	29
2.20 Symmetric and Antisymmetric Tensors	31
2.21 The Dual Vector of an Antisymmetric Tensor.....	32
2.22 Eigenvalues and Eigenvectors of a Tensor.....	34
2.23 Principal Values and Principal Directions of Real Symmetric Tensors	38
2.24 Matrix of a Tensor with Respect to Principal Directions	39
2.25 Principal Scalar Invariants of a Tensor.....	40
Problems for Part B.....	41

Part C: Tensor Calculus	45
2.26 Tensor-Valued Functions of a Scalar.....	45
2.27 Scalar Field and Gradient of a Scalar Function.....	47
2.28 Vector Field and Gradient of a Vector Function.....	50
2.29 Divergence of a Vector Field and Divergence of a Tensor Field.....	50
2.30 Curl of a Vector Field.....	52
2.31 Laplacian of a Scalar Field.....	52
2.32 Laplacian of a Vector Field.....	52
Problems for Part C.....	53
Part D: Curvilinear Coordinates	54
2.33 Polar Coordinates.....	54
2.34 Cylindrical Coordinates.....	59
2.35 Spherical Coordinates.....	61
Problems for Part D.....	67
Chapter 3 Kinematics of a Continuum	69
3.1 Description of Motions of a Continuum.....	69
3.2 Material Description and Spatial Description.....	72
3.3 Material Derivative.....	74
3.4 Acceleration of a Particle.....	76
3.5 Displacement Field.....	81
3.6 Kinematic Equation for Rigid Body Motion.....	82
3.7 Infinitesimal Deformation.....	84
3.8 Geometrical Meaning of the Components of the Infinitesimal Strain Tensor.....	88
3.9 Principal Strain.....	93
3.10 Dilatation.....	93
3.11 The Infinitesimal Rotation Tensor.....	94
3.12 Time Rate of Change of a Material Element.....	95
3.13 The Rate of Deformation Tensor.....	95
3.14 The Spin Tensor and the Angular Velocity Vector.....	98
3.15 Equation of Conservation of Mass.....	99
3.16 Compatibility Conditions for Infinitesimal Strain Components.....	101
3.17 Compatibility Condition for Rate of Deformation Components.....	104
3.18 Deformation Gradient.....	105
3.19 Local Rigid Body Motion.....	106
3.20 Finite Deformation.....	106
3.21 Polar Decomposition Theorem.....	110
3.22 Calculation of Stretch and Rotation Tensors from the Deformation Gradient.....	111
3.23 Right Cauchy-Green Deformation Tensor.....	114
3.24 Lagrangian Strain Tensor.....	118

3.25	Left Cauchy-Green Deformation Tensor	121
3.26	Eulerian Strain Tensor	125
3.27	Change of Area Due to Deformation.....	128
3.28	Change of Volume Due to Deformation.....	129
3.29	Components of Deformation Tensors in Other Coordinates.....	131
3.30	Current Configuration as the Reference Configuration.....	139
Appendix 3.1:	Necessary and Sufficient Conditions for Strain Compatibility	140
Appendix 3.2:	Positive Definite Symmetric Tensors	143
Appendix 3.3:	The Positive Definite Root of $\mathbf{U}^2 = \mathbf{D}$	143
	Problems for Chapter 3	145
Chapter 4	Stress and Integral Formulations of General Principles.....	155
4.1	Stress Vector	155
4.2	Stress Tensor	156
4.3	Components of Stress Tensor.....	158
4.4	Symmetry of Stress Tensor: Principle of Moment of Momentum	159
4.5	Principal Stresses	162
4.6	Maximum Shearing Stresses.....	162
4.7	Equations of Motion: Principle of Linear Momentum.....	168
4.8	Equations of Motion in Cylindrical and Spherical Coordinates	170
4.9	Boundary Condition for the Stress Tensor	171
4.10	Piola Kirchhoff Stress Tensors	174
4.11	Equations of Motion Written with Respect to the Reference Configuration	179
4.12	Stress Power	180
4.13	Stress Power in Terms of the Piola-Kirchhoff Stress Tensors.....	181
4.14	Rate of Heat Flow Into a Differential Element by Conduction.....	183
4.15	Energy Equation.....	184
4.16	Entropy Inequality.....	185
4.17	Entropy Inequality in Terms of the Helmholtz Energy Function.....	186
4.18	Integral Formulations of the General Principles of Mechanics	187
Appendix 4.1:	Determination of Maximum Shearing Stress and the Planes on Which It Acts	191
	Problems for Chapter 4	194
Chapter 5	The Elastic Solid	201
5.1	Mechanical Properties.....	201
5.2	Linearly Elastic Solid	204
Part A:	Isotropic Linearly Elastic Solid.....	207
5.3	Isotropic Linearly Elastic Solid.....	207
5.4	Young's Modulus, Poisson's Ratio, Shear Modulus, and Bulk Modulus.....	209
5.5	Equations of the Infinitesimal Theory of Elasticity	213

5.6	Navier Equations of Motion for Elastic Medium.....	215
5.7	Navier Equations in Cylindrical and Spherical Coordinates.....	216
5.8	Principle of Superposition	218
A.1	Plane Elastic Waves	218
5.9	Plane Irrotational Waves.....	218
5.10	Plane Equivoluminal Waves.....	221
5.11	Reflection of Plane Elastic Waves.....	226
5.12	Vibration of an Infinite Plate	229
A.2	Simple Extension, Torsion and Pure Bending	231
5.13	Simple Extension	231
5.14	Torsion of a Circular Cylinder.....	234
5.15	Torsion of a Noncircular Cylinder: St. Venant's Problem.....	239
5.16	Torsion of Elliptical Bar.....	240
5.17	Prandtl's Formulation of the Torsion Problem.....	242
5.18	Torsion of a Rectangular Bar.....	246
5.19	Pure Bending of a Beam	247
A.3	Plane Stress and Plane Strain Solutions	250
5.20	Plane Strain Solutions.....	250
5.21	Rectangular Beam Bent by End Couples.....	253
5.22	Plane Stress Problem	254
5.23	Cantilever Beam with End Load.....	255
5.24	Simply Supported Beam Under Uniform Load.....	258
5.25	Slender Bar Under Concentrated Forces and St. Venant's Principle	260
5.26	Conversion for Strains Between Plane Strain and Plane Stress Solutions	262
5.27	Two-Dimensional Problems in Polar Coordinates.....	264
5.28	Stress Distribution Symmetrical About an Axis.....	265
5.29	Displacements for Symmetrical Stress Distribution in Plane Stress Solution.....	265
5.30	Thick-Walled Circular Cylinder Under Internal and External Pressure.....	267
5.31	Pure Bending of a Curved Beam	268
5.32	Initial Stress in a Welded Ring.....	270
5.33	Airy Stress Function $\varphi = f(r) \cos n\theta$ and $\varphi = f(r) \sin n\theta$	270
5.34	Stress Concentration Due to a Small Circular Hole in a Plate under Tension.....	274
5.35	Stress Concentration Due to a Small Circular Hole in a Plate under Pure Shear	276
5.36	Simple Radial Distribution of Stresses in a Wedge Loaded at the Apex	277
5.37	Concentrated Line Load on a 2-D Half-Space: The Flamont Problem.....	278
A.4	Elastostatic Problems Solved with Potential Functions	279
5.38	Fundamental Potential Functions for Elastostatic Problems	279
5.39	Kelvin Problem: Concentrated Force at the Interior of an Infinite Elastic Space.....	290
5.40	Boussinesq Problem: Normal Concentrated Load on an Elastic Half-Space.....	293
5.41	Distributive Normal Load on the Surface of an Elastic Half-Space	296
5.42	Hollow Sphere Subjected to Uniform Internal and External Pressure	297

5.43	Spherical Hole in a Tensile Field.....	298
5.44	Indentation by a Rigid Flat-Ended Smooth Indenter on an Elastic Half-Space	300
5.45	Indentation by a Smooth Rigid Sphere on an Elastic Half-Space	302
Appendix 5A.1: Solution of the Integral Equation in Section 5.45		306
Problems for Chapter 5, Part A		309
Part B: Anisotropic Linearly Elastic Solid		319
5.46	Constitutive Equations for an Anisotropic Linearly Elastic Solid.....	319
5.47	Plane of Material Symmetry.....	321
5.48	Constitutive Equation for a Monoclinic Linearly Elastic Solid.....	323
5.49	Constitutive Equation for an Orthotropic Linearly Elastic Solid.....	324
5.50	Constitutive Equation for a Transversely Isotropic Linearly Elastic Material.....	325
5.51	Constitutive Equation for an Isotropic Linearly Elastic Solid.....	327
5.52	Engineering Constants for an Isotropic Linearly Elastic Solid.....	328
5.53	Engineering Constants for a Transversely Isotropic Linearly Elastic Solid.....	329
5.54	Engineering Constants for an Orthotropic Linearly Elastic Solid	330
5.55	Engineering Constants for a Monoclinic Linearly Elastic Solid	332
Problems for Part B.....		333
Part C: Isotropic Elastic Solid Under Large Deformation		334
5.56	Change of Frame.....	334
5.57	Constitutive Equation for an Elastic Medium Under Large Deformation.....	338
5.58	Constitutive Equation for an Isotropic Elastic Medium.....	340
5.59	Simple Extension of an Incompressible Isotropic Elastic Solid	342
5.60	Simple Shear of an Incompressible Isotropic Elastic Rectangular Block	343
5.61	Bending of an Incompressible Isotropic Rectangular Bar.....	344
5.62	Torsion and Tension of an Incompressible Isotropic Solid Cylinder	347
Appendix 5C.1: Representation of Isotropic Tensor-Valued Functions		349
Problems for Part C.....		351
Chapter 6	Newtonian Viscous Fluid	353
6.1	Fluids	353
6.2	Compressible and Incompressible Fluids.....	354
6.3	Equations of Hydrostatics	355
6.4	Newtonian Fluids	357
6.5	Interpretation of λ and μ	358
6.6	Incompressible Newtonian Fluid.....	359
6.7	Navier-Stokes Equations for Incompressible Fluids.....	360
6.8	Navier-Stokes Equations for Incompressible Fluids in Cylindrical and Spherical Coordinates.....	364
6.9	Boundary Conditions	365
6.10	Streamline, Pathline, Steady, Unsteady, Laminar, and Turbulent Flow.....	365
6.11	Plane Couette Flow	368

6.12	Plane Poiseuille Flow.....	368
6.13	Hagen-Poiseuille Flow	371
6.14	Plane Couette Flow of Two Layers of Incompressible Viscous Fluids	372
6.15	Couette Flow	374
6.16	Flow Near an Oscillating Plane.....	375
6.17	Dissipation Functions for Newtonian Fluids.....	376
6.18	Energy Equation for a Newtonian Fluid	378
6.19	Vorticity Vector	379
6.20	Irrotational Flow.....	381
6.21	Irrotational Flow of an Inviscid Incompressible Fluid of Homogeneous Density.....	382
6.22	Irrotational Flows As Solutions of Navier-Stokes Equation	384
6.23	Vorticity Transport Equation for Incompressible Viscous Fluid with a Constant Density.....	385
6.24	Concept of a Boundary Layer	388
6.25	Compressible Newtonian Fluid	389
6.26	Energy Equation in Terms of Enthalpy	390
6.27	Acoustic Wave	392
6.28	Irrotational, Barotropic Flows of an Inviscid Compressible Fluid	395
6.29	One-Dimensional Flow of a Compressible Fluid	398
6.30	Steady Flow of a Compressible Fluid Exiting a Large Tank Through a Nozzle.....	399
6.31	Steady Laminar Flow of a Newtonian Fluid in a Thin Elastic Tube: An Application to Pressure-Flow Relation in a Pulmonary Blood Vessel.....	401
	Problems for Chapter 6.....	403
Chapter 7	The Reynolds Transport Theorem and Applications.....	411
7.1	Green's Theorem.....	411
7.2	Divergence Theorem.....	414
7.3	Integrals Over a Control Volume and Integrals Over a Material Volume.....	417
7.4	The Reynolds Transport Theorem.....	418
7.5	The Principle of Conservation of Mass	420
7.6	The Principle of Linear Momentum.....	422
7.7	Moving Frames	427
7.8	A Control Volume Fixed with Respect to a Moving Frame	430
7.9	The Principle of Moment of Momentum.....	430
7.10	The Principle of Conservation of Energy	432
7.11	The Entropy Inequality: The Second Law of Thermodynamics.....	436
	Problems for Chapter 7.....	438

Chapter 8	Non-Newtonian Fluids	443
	Part A: Linear Viscoelastic Fluid.....	444
8.1	Linear Maxwell Fluid	444
8.2	A Generalized Linear Maxwell Fluid with Discrete Relaxation Spectra	450
8.3	Integral Form of the Linear Maxwell Fluid and of the Generalized Linear Maxwell Fluid with Discrete Relaxation Spectra.....	451
8.4	A Generalized Linear Maxwell Fluid with a Continuous Relaxation Spectrum.....	452
8.5	Computation of Relaxation Spectrum and Relaxation Function.....	454
	Part B: Nonlinear Viscoelastic Fluid	456
8.6	Current Configuration as Reference Configuration.....	456
8.7	Relative Deformation Gradient.....	457
8.8	Relative Deformation Tensors	459
8.9	Calculations of the Relative Deformation Tensor	460
8.10	History of the Relative Deformation Tensor and Rivlin-Ericksen Tensors	463
8.11	Rivlin-Ericksen Tensors in Terms of Velocity Gradient: The Recursive Formula.....	468
8.12	Relation Between Velocity Gradient and Deformation Gradient	471
8.13	Transformation Law for the Relative Deformation Tensors Under a Change of Frame	471
8.14	Transformation Law for Rivlin-Ericksen Tensors Under a Change of Frame.....	474
8.15	Incompressible Simple Fluid	474
8.16	Special Single Integral-Type Nonlinear Constitutive Equations.....	475
8.17	General Single Integral-Type Nonlinear Constitutive Equations.....	478
8.18	Differential-Type Constitutive Equations for Incompressible Fluids	481
8.19	Objective Rate of Stress	483
8.20	Rate-Type Constitutive Equations	487
	Part C: Viscometric Flow of an Incompressible Simple Fluid.....	491
8.21	Viscometric Flow	491
8.22	Stresses in Viscometric Flow of an Incompressible Simple Fluid	493
8.23	Channel Flow	495
8.24	Couette Flow	497
	Appendix 8.1: Gradient of Second-Order Tensor for Orthogonal Coordinates	501
	Problems for Chapter 8	506
	References	511
	Index.....	513

This page intentionally left blank

Preface to the Fourth Edition

The first as well as the second (SI/Metric) editions of this book, published in 1974 and 1978, respectively, were prepared for use as a text for an undergraduate course in continuum mechanics. The third edition, published in 1994, broadened the coverage of the earlier editions so that it could be used as a text for a one- or two-semester graduate course in continuum mechanics. In this fourth edition, the coverage is further broadened so that it may be used as a text for a one- or two-semester graduate course in either continuum mechanics or theory of elasticity. In the following, we list the additions and changes to the third edition:

- Seven new appendices are included in this new edition: (1) derivation of the necessary and sufficient conditions for strain compatibility, (2) on positive definite symmetric tensors, (3) on the positive definite roots of $[\mathbf{U}]^2 = \mathbf{a}$ a positive definite diagonal matrix, (4) determination of maximum shearing stress and the planes on which it acts, (5) representation of isotropic tensor-valued function, (6) on the solution of an integral equation, related to the indentation problem in elasticity, and (7) derivation of the components of the gradient of a second-order tensor in cylindrical and spherical coordinates. We expect that readers of this text are familiar with matrices; therefore, the appendix on matrices, which was in the older editions, has been eliminated.
- The title of Chapter 4 has been changed to “Stresses and Integral Formulations of General Principles.” The last section of this chapter, after the subject of stresses is concluded, is devoted to the integral formulation of the field equations. The purpose of this additional section is twofold: (1) to provide an alternate approach to the formulation of field equations, and (2) to put all field equations in one place for easy reference before specific constitutive models are discussed. This approach is favored by several reviewers of the current edition; the authors are indebted to their suggestions. The title of Chapter 7 has been changed to “The Reynolds Theorem and Applications.”
- In the chapter on elasticity (Chapter 5), there are now 18 sections on plane strain and plane stress problems in this edition, compared to five in the third edition. In addition, Prandtl’s formulation of the torsion problem is now included in the text rather than in the problems. Furthermore, nine new sections on the potential function approach to the solutions of three-dimensional elastostatic problems, such as the Kelvin problem, the Boussinesq problem, and the indentation problems, have been added. Selected potential functions and the stress field and strain field they generated are given in examples (rather than in tabulated form) from pedagogical considerations. That is, most examples are designed to lead students to complete the derivations rather than simply go to a table. This approach is consistent with our approach since the first edition—that one can cover advanced topics in an elementary way using examples that go from simple to complex.
- Invariant definitions of the Laplacian of a scalar function and of a vector function have been added to Part D of Chapter 2, including detail derivations of their components in cylindrical and spherical coordinates. Components of the gradient of a second-order tensor, which is a third-order tensor, are derived in an appendix in Chapter 8 for these two coordinate systems. With these additions, the text is self-sufficient insofar as obtaining, in cylindrical coordinates and spherical coordinates, all the mathematical expressions and equations used in this text (e.g., material derivatives, divergence of the stress tensor, Navier-Stokes equations, scalar and vector potential functions, Rivlin-Ericksen tensors, and so on). Although all these results can be obtained very elegantly using a generalized tensor approach, there are definite merits in deriving them using basic vector operations, particularly when only cylindrical and spherical coordinates are of interest.

- Some problems and examples in the previous editions have been revised or eliminated from this edition. There are about 10% more problems and examples in this new edition.
- For instructors using this text in a university course, an instructor's solutions manual is available by registering at the publisher's Website, www.textbooks.elsevier.com.

The authors would like to acknowledge, with thanks, our receipt of a grant from the Elsevier Publishing Company, which has encouraged us to undertake this task resulting in this fourth edition. We also want to thank Professor Gerard Artesian of Columbia University, Professor William C. Van Buskirk of the New Jersey Institute of Technology, Professor Rebecca Dupaix of Ohio State University, Professor Mark Kachanov of Tufts University, and Professor David Nicholson of the University of Central Florida for their valuable suggestions for this edition.

W. Michael Lai
David Rubin
Erhard Krempf
January 2009

Introduction

1.1 INTRODUCTION

Matter is formed of molecules, which in turn consist of atoms and subatomic particles. Thus, matter is not continuous. However, there are many aspects of everyday experience regarding the behaviors of materials, such as the deflection of a structure under loads, the rate of discharge of water in a pipe under a pressure gradient, or the drag force experienced by a body moving in the air, that can be described and predicted with theories that pay no attention to the molecular structure of materials. The theory that aims to describe relationships among gross phenomena, neglecting the structure of material on a smaller scale, is known as *continuum theory*. The continuum theory regards matter as indefinitely divisible. Thus, within this theory, one accepts the idea of an infinitesimal volume of materials, referred to as a *particle* in the continuum, and in every neighborhood of a particle there are always neighboring particles.

Whether the continuum theory is justified or not depends on the given situation. For example, although the continuum approach adequately describes the behaviors of real materials in many circumstances, it does not yield results that are in accord with experimental observations in the propagation of waves of extremely small wavelength. On the other hand, a rarefied gas may be adequately described by a continuum in certain circumstances. At any rate, it is misleading to justify the continuum approach on the basis of the number of molecules in a given volume. After all, an infinitesimal volume in the limit contains no molecules at all. Neither is it necessary to infer that quantities occurring in a continuum theory must be interpreted as certain particular statistical averages. In fact, it has been known that the same continuum equations can be arrived at by different hypotheses about the molecular structure and definitions of gross variables. Though molecular-statistical theory, whenever available, does enhance understanding of the continuum theory, the point to be made is simply that whether the continuum theory is justified in a given situation is a matter of experimental test and of philosophy. Suffice it to say that more than 200 years of experience have justified such a theory in a wide variety of situations.

1.2 WHAT IS CONTINUUM MECHANICS?

Continuum mechanics studies the response of materials to different loading conditions. Its subject matter can be divided into two main parts: (1) general principles common to all media and (2) constitutive equations defining idealized materials. The general principles are axioms considered to be self-evident from our experience with the physical world, such as conservation of mass; the balance of linear momentum, moment of

momentum, and energy; and the entropy inequality law. Mathematically, there are two equivalent forms of the general principles: (1) the integral form, formulated for a finite volume of material in the continuum, and (2) the field equations for differential volume of material (particles) at every point of the field of interest. Field equations are often derived from the integral form. They can also be derived directly from the free body of a differential volume. The latter approach seems to better suit beginners. In this text both approaches are presented. Field equations are important wherever the variations of the variables in the field are either of interest by themselves or are needed to get the desired information. On the other hand, the integral forms of conservation laws lend themselves readily to certain approximate solutions.

The second major part of the theory of continuum mechanics concerns the “constitutive equations” that are used to define idealized materials. Idealized materials represent certain aspects of the mechanical behaviors of natural materials. For example, for many materials, under restricted conditions, the deformation caused by the application of loads disappears with the removal of the loads. This aspect of material behaviors is represented by the constitutive equation of an elastic body. Under even more restricted conditions, the state of stress at a point depends linearly on the change of lengths and angles suffered by elements at the point measured from the state where the external and internal forces vanish. The previous expression defines the linearly elastic solid. Another example is supplied by the classical definition of viscosity, which is based on the assumption that the state of stress depends linearly on the instantaneous rates of change of lengths and angles. Such a constitutive equation defines the linearly viscous fluid. The mechanical behaviors of real materials vary not only from material to material but also with different loading conditions for a given material. This leads to the formulation of many constitutive equations defining the many different aspects of material behaviors.

In this text we present four idealized models and study the behaviors they represent by means of some solutions of boundary-value problems. The idealized materials chosen are (1) the isotropic and anisotropic linearly elastic solid, (2) the isotropic incompressible nonlinear elastic solid, (3) the linearly viscous fluid, including the inviscid fluid, and (4) the non-Newtonian incompressible fluid.

One important requirement that must be satisfied by all quantities used in the formulation of a physical law is that they be coordinate invariant. In the following chapter, we discuss such quantities.

Tensors

As mentioned in the introduction, all laws of continuum mechanics must be formulated in terms of quantities that are independent of coordinates. It is the purpose of this chapter to introduce such mathematical entities. We begin by introducing a shorthand notation—the *indicial notation*—in Part A of this chapter, which is followed by the concept of tensors, introduced as a linear transformation in Part B. Tensor calculus is considered in Part C, and expressions for the components in cylindrical and spherical coordinates for tensors resulting from operations such as the gradient, the divergence, and the Laplacian of them are derived in Part D.

PART A: INDICIAL NOTATION

2.1 SUMMATION CONVENTION, DUMMY INDICES

Consider the sum

$$s = a_1x_1 + a_2x_2 + \dots + a_nx_n. \quad (2.1.1)$$

We can write the preceding equation in a compact form using a summation sign:

$$s = \sum_{i=1}^n a_i x_i. \quad (2.1.2)$$

It is obvious that the following equations have exactly the same meaning as Eq. (2.1.2):

$$s = \sum_{j=1}^n a_j x_j, \quad s = \sum_{m=1}^n a_m x_m, \quad s = \sum_{k=1}^n a_k x_k. \quad (2.1.3)$$

The index i in Eq. (2.1.2), or j or m or k in Eq. (2.1.3), is a dummy index in the sense that the sum is independent of the letter used for the index. We can further simplify the writing of Eq. (2.1.1) if we adopt the following convention: Whenever an index is repeated once, it is a dummy index indicating a summation with the index running through the integral numbers $1, 2, \dots, n$.

This convention is known as *Einstein's summation convention*. Using this convention, Eq. (2.1.1) can be written simply as:

$$s = a_i x_i \quad \text{or} \quad s = a_j x_j \quad \text{or} \quad s = a_m x_m, \quad \text{etc.} \quad (2.1.4)$$

It is emphasized that expressions such as $a_i b_i x_i$ or $a_m b_m x_m$ are *not* defined within this convention. That is, *an index should never be repeated more than once* when the summation convention is used. Therefore, an expression of the form

$$\sum_{i=1}^n a_i b_i x_i,$$

must retain its summation sign.

In the following, we shall always take the number of terms n in a summation to be 3, so that, for example:

$$a_i x_i = a_1 x_1 + a_2 x_2 + a_3 x_3, \quad a_{ii} = a_{11} + a_{22} + a_{33}.$$

The summation convention obviously can be used to express a double sum, a triple sum, and so on. For example, we can write:

$$\alpha = \sum_{i=1}^3 \sum_{j=1}^3 a_{ij} x_i x_j$$

concisely as

$$\alpha = a_{ij} x_i x_j. \quad (2.1.5)$$

Expanding in full, Eq. (2.1.5) gives a sum of nine terms in the right-hand side, i.e.,

$$\begin{aligned} \alpha = a_{ij} x_i x_j &= a_{11} x_1 x_1 + a_{12} x_1 x_2 + a_{13} x_1 x_3 + a_{21} x_2 x_1 + a_{22} x_2 x_2 + a_{23} x_2 x_3 \\ &+ a_{31} x_3 x_1 + a_{32} x_3 x_2 + a_{33} x_3 x_3. \end{aligned}$$

For newcomers, it is probably better to perform the preceding expansion in two steps: first, sum over i , and then sum over j (or vice versa), i.e.,

$$a_{ij} x_i x_j = a_{1j} x_1 x_j + a_{2j} x_2 x_j + a_{3j} x_3 x_j,$$

where

$$a_{1j} x_1 x_j = a_{11} x_1 x_1 + a_{12} x_1 x_2 + a_{13} x_1 x_3,$$

and so on. Similarly, the indicial notation $a_{ijk} x_i x_j x_k$ represents a triple sum of 27 terms, that is,

$$\sum_{i=1}^3 \sum_{j=1}^3 \sum_{k=1}^3 a_{ijk} x_i x_j x_k = a_{ijk} x_i x_j x_k. \quad (2.1.6)$$

2.2 FREE INDICES

Consider the following system of three equations:

$$\begin{aligned} x_1' &= a_{11} x_1 + a_{12} x_2 + a_{13} x_3, \\ x_2' &= a_{21} x_1 + a_{22} x_2 + a_{23} x_3, \\ x_3' &= a_{31} x_1 + a_{32} x_2 + a_{33} x_3. \end{aligned} \quad (2.2.1)$$

Using the summation convention, Eqs. (2.2.1) can be written as:

$$\begin{aligned} x_1' &= a_{1m} x_m, \\ x_2' &= a_{2m} x_m, \\ x_3' &= a_{3m} x_m, \end{aligned} \quad (2.2.2)$$

which can be shortened into

$$x'_i = a_{im} x_m, \quad i = 1, 2, 3. \tag{2.2.3}$$

An index that appears *only once* in each term of an equation such as the index i in Eq. (2.2.3) is called a *free index*. Unless stated otherwise, we agree that a free index takes on the integral number 1, 2 or 3. Thus, $x'_i = a_{im}x_m$ is shorthand for three equations, each having a sum of three terms on its right-hand side. Another simple example of a free index is the following equation defining the components of a vector \mathbf{a} in terms of a dot product with each of the base vectors \mathbf{e}_i ,

$$a_i = \mathbf{a} \cdot \mathbf{e}_i, \tag{2.2.4}$$

and clearly the vector \mathbf{a} can also be expressed in terms of its components as

$$\mathbf{a} = a_i \mathbf{e}_i. \tag{2.2.5}$$

A further example is given by

$$\mathbf{e}'_i = Q_{mi} \mathbf{e}_m, \tag{2.2.6}$$

representing

$$\begin{aligned} \mathbf{e}'_1 &= Q_{11}\mathbf{e}_1 + Q_{21}\mathbf{e}_2 + Q_{31}\mathbf{e}_3, \\ \mathbf{e}'_2 &= Q_{12}\mathbf{e}_1 + Q_{22}\mathbf{e}_2 + Q_{32}\mathbf{e}_3, \\ \mathbf{e}'_3 &= Q_{13}\mathbf{e}_1 + Q_{23}\mathbf{e}_2 + Q_{33}\mathbf{e}_3. \end{aligned} \tag{2.2.7}$$

We note that $x'_j = a_{jm}x_m$ is the same as Eq. (2.2.3) and $\mathbf{e}'_j = Q_{mj}\mathbf{e}_m$ is the same as Eq. (2.2.6). However, $a_i = b_j$ is a meaningless equation. *The free index appearing in every term of an equation must be the same.* Thus, the following equations are meaningful:

$$a_i + k_i = c_i \quad \text{or} \quad a_i + b_i c_j d_j = f_i.$$

If there are two free indices appearing in an equation such as:

$$T_{ij} = A_{im}A_{jm}, \tag{2.2.8}$$

then the equation is a shorthand for the nine equations, each with a sum of three terms on the right-hand side. In fact,

$$\begin{aligned} T_{11} &= A_{1m}A_{1m} = A_{11}A_{11} + A_{12}A_{12} + A_{13}A_{13}, \\ T_{12} &= A_{1m}A_{2m} = A_{11}A_{21} + A_{12}A_{22} + A_{13}A_{23}, \\ T_{13} &= A_{1m}A_{3m} = A_{11}A_{31} + A_{12}A_{32} + A_{13}A_{33}, \\ T_{21} &= A_{2m}A_{1m} = A_{21}A_{11} + A_{22}A_{12} + A_{23}A_{13}, \\ &\dots\dots\dots \\ T_{33} &= A_{3m}A_{3m} = A_{31}A_{31} + A_{32}A_{32} + A_{33}A_{33}. \end{aligned}$$

2.3 THE KRONECKER DELTA

The *Kronecker delta*, denoted by δ_{ij} , is defined as:

$$\delta_{ij} = \begin{cases} 1 & \text{if } i = j, \\ 0 & \text{if } i \neq j. \end{cases} \tag{2.3.1}$$

That is,

$$\delta_{11} = \delta_{22} = \delta_{33} = 1, \quad \delta_{12} = \delta_{13} = \delta_{21} = \delta_{23} = \delta_{31} = \delta_{32} = 0. \quad (2.3.2)$$

In other words, the matrix of the Kronecker delta is the identity matrix:

$$[\delta_{ij}] = \begin{bmatrix} \delta_{11} & \delta_{12} & \delta_{13} \\ \delta_{21} & \delta_{22} & \delta_{23} \\ \delta_{31} & \delta_{32} & \delta_{33} \end{bmatrix} = \begin{bmatrix} 1 & 0 & 0 \\ 0 & 1 & 0 \\ 0 & 0 & 1 \end{bmatrix}. \quad (2.3.3)$$

We note the following:

(a) $\delta_{ii} = \delta_{11} + \delta_{22} + \delta_{33} = 1 + 1 + 1,$

that is,

$$\delta_{ii} = 3. \quad (2.3.4)$$

(b) $\delta_{1m}a_m = \delta_{11}a_1 + \delta_{12}a_2 + \delta_{13}a_3 = \delta_{11}a_1 = a_1,$

$$\delta_{2m}a_m = \delta_{21}a_1 + \delta_{22}a_2 + \delta_{23}a_3 = \delta_{22}a_2 = a_2,$$

$$\delta_{3m}a_m = \delta_{31}a_1 + \delta_{32}a_2 + \delta_{33}a_3 = \delta_{33}a_3 = a_3,$$

that is,

$$\delta_{im}a_m = a_i. \quad (2.3.5)$$

(c) $\delta_{1m}T_{mj} = \delta_{11}T_{1j} + \delta_{12}T_{2j} + \delta_{13}T_{3j} = T_{1j},$

$$\delta_{2m}T_{mj} = \delta_{21}T_{1j} + \delta_{22}T_{2j} + \delta_{23}T_{3j} = T_{2j},$$

$$\delta_{3m}T_{mj} = \delta_{31}T_{1j} + \delta_{32}T_{2j} + \delta_{33}T_{3j} = T_{3j},$$

that is,

$$\delta_{im}T_{mj} = T_{ij}. \quad (2.3.6)$$

In particular,

$$\delta_{im}\delta_{mj} = \delta_{ij}, \quad \delta_{im}\delta_{mn}\delta_{nj} = \delta_{ij}, \quad \text{etc.} \quad (2.3.7)$$

(d) If $\mathbf{e}_1, \mathbf{e}_2, \mathbf{e}_3$ are unit vectors perpendicular to one another, then clearly,

$$\mathbf{e}_i \cdot \mathbf{e}_j = \delta_{ij}. \quad (2.3.8)$$

2.4 THE PERMUTATION SYMBOL

The *permutation symbol*, denoted by ε_{ijk} , is defined by:

$$\varepsilon_{ijk} = \begin{cases} 1 \\ -1 \\ 0 \end{cases} \equiv \text{according to whether } i, j, k \begin{cases} \text{form an even} \\ \text{form an odd} \\ \text{do not form} \end{cases} \text{ permutation of } 1, 2, 3, \quad (2.4.1)$$

i.e.,

$$\begin{aligned} \varepsilon_{123} = \varepsilon_{231} = \varepsilon_{312} &= +1, \\ \varepsilon_{213} = \varepsilon_{321} = \varepsilon_{132} &= -1, \\ \varepsilon_{111} = \varepsilon_{112} = \varepsilon_{222} &= \dots = 0. \end{aligned} \quad (2.4.2)$$

We note that

$$\varepsilon_{ijk} = \varepsilon_{jki} = \varepsilon_{kij} = -\varepsilon_{jik} = -\varepsilon_{kji} - \varepsilon_{ikj}. \quad (2.4.3)$$

If $\{\mathbf{e}_1, \mathbf{e}_2, \mathbf{e}_3\}$ is a right-handed triad, then

$$\mathbf{e}_1 \times \mathbf{e}_2 = \mathbf{e}_3, \quad \mathbf{e}_2 \times \mathbf{e}_1 = -\mathbf{e}_3, \quad \mathbf{e}_2 \times \mathbf{e}_3 = \mathbf{e}_1, \quad \mathbf{e}_3 \times \mathbf{e}_2 = -\mathbf{e}_1, \quad \text{etc.}, \quad (2.4.4)$$

which can be written in a short form as

$$\mathbf{e}_i \times \mathbf{e}_j = \varepsilon_{ijk} \mathbf{e}_k = \varepsilon_{jki} \mathbf{e}_k = \varepsilon_{kij} \mathbf{e}_k. \quad (2.4.5)$$

Now, if $\mathbf{a} = a_i \mathbf{e}_i$ and $\mathbf{b} = b_j \mathbf{e}_j$, then, since the cross-product is distributive, we have

$$\mathbf{a} \times \mathbf{b} = (a_i \mathbf{e}_i) \times (b_j \mathbf{e}_j) = a_i b_j (\mathbf{e}_i \times \mathbf{e}_j) = a_i b_j \varepsilon_{ijk} \mathbf{e}_k. \quad (2.4.6)$$

The following useful identity can be proven (see Prob. 2.12):

$$\varepsilon_{ijm} \varepsilon_{klm} = \delta_{ik} \delta_{jl} - \delta_{il} \delta_{jk}. \quad (2.4.7)$$

2.5 INDICIAL NOTATION MANIPULATIONS

(a) *Substitution:* If

$$a_i = U_{im} b_m, \quad (i)$$

and

$$b_i = V_{im} c_m, \quad (ii)$$

then, in order to substitute the b_i in Eq. (ii) into the b_m in Eq. (i), we must first change the free index in Eq. (ii) from i to m and the dummy index m to some other letter—say, n —so that

$$b_m = V_{mn} c_n. \quad (iii)$$

Now Eqs. (i) and (iii) give

$$a_i = U_{im} V_{mn} c_n. \quad (iv)$$

Note that Eq. (iv) represents three equations, each having a sum of nine terms on its right-hand side.

(b) *Multiplication:* If

$$p = a_m b_m \quad \text{and} \quad q = c_m d_m,$$

then

$$pq = a_m b_m c_n d_n.$$

It is important to note that $pq \neq a_m b_m c_m d_m$. In fact, the right-hand side of this expression, i.e., $a_m b_m c_m d_m$, is not even defined in the summation convention, and further, it is obvious that

$$pq \neq \sum_{m=1}^3 a_m b_m c_m d_m.$$

Since the dot product of vectors is distributive, therefore, if $\mathbf{a} = a_i \mathbf{e}_i$ and $\mathbf{b} = b_j \mathbf{e}_j$, then

$$\mathbf{a} \cdot \mathbf{b} = (a_i \mathbf{e}_i) \cdot (b_j \mathbf{e}_j) = a_i b_j (\mathbf{e}_i \cdot \mathbf{e}_j).$$

In particular, if $\mathbf{e}_1, \mathbf{e}_2, \mathbf{e}_3$ are unit vectors perpendicular to one another, then $\mathbf{e}_i \cdot \mathbf{e}_j = \delta_{ij}$ so that

$$\mathbf{a} \cdot \mathbf{b} = a_i b_j \delta_{ij} = a_i b_i = a_1 b_1 + a_2 b_2 + a_3 b_3,$$

which is the familiar expression for the evaluation of the dot product in terms of the vector components.

(c) *Factoring*: If

$$T_{ij} n_j - \lambda n_i = 0,$$

then, using the Kronecker delta, we can write $n_i = \delta_{ij} n_j$, so that we have

$$T_{ij} n_j - \lambda \delta_{ij} n_j = 0.$$

Thus,

$$(T_{ij} - \lambda \delta_{ij}) n_j = 0.$$

(d) *Contraction*: The operation of identifying two indices is known as a *contraction*. Contraction indicates a sum on the index. For example, T_{ii} is the contraction of T_{ij} with

$$T_{ii} = T_{11} + T_{22} + T_{33}.$$

If

$$T_{ij} = \lambda \Delta \delta_{ij} + 2\mu E_{ij},$$

then

$$T_{ii} = \lambda \Delta \delta_{ii} + 2\mu E_{ii} = 3\lambda \Delta + 2\mu E_{ii}.$$

PROBLEMS FOR PART A

2.1 Given

$$[S_{ij}] = \begin{bmatrix} 1 & 0 & 2 \\ 0 & 1 & 2 \\ 3 & 0 & 3 \end{bmatrix} \quad \text{and} \quad [a_i] = \begin{bmatrix} 1 \\ 2 \\ 3 \end{bmatrix},$$

evaluate (a) S_{ii} , (b) $S_{ij} S_{ij}$, (c) $S_{ji} S_{ji}$, (d) $S_{jk} S_{kj}$, (e) $a_m a_m$, (f) $S_{mn} a_m a_n$, and (g) $S_{nm} a_m a_n$.

2.2 Determine which of these equations has an identical meaning with $a_i = Q_{ij} a'_j$.

(a) $a_p = Q_{pm} a'_m$, (b) $a_p = Q_{qp} a'_q$, (c) $a_m = a'_n Q_{mn}$.

2.3 Given the following matrices

$$[a_i] = \begin{bmatrix} 1 \\ 0 \\ 2 \end{bmatrix}, \quad [B_{ij}] = \begin{bmatrix} 2 & 3 & 0 \\ 0 & 5 & 1 \\ 0 & 2 & 1 \end{bmatrix},$$

demonstrate the equivalence of the subscripted equations and the corresponding matrix equations in the following two problems:

(a) $b_i = B_{ij} a_j$ and $[b] = [B][a]$ and (b) $s = B_{ij} a_i a_j$ and $s = [a]^T [B][a]$.

- 2.4 Write in indicial notation the matrix equation (a) $[A] = [B][C]$, (b) $[D] = [B]^T[C]$ and (c) $[E] = [B]^T[C][F]$.
- 2.5 Write in indicial notation the equation (a) $s = A_1^2 + A_2^2 + A_3^2$ and (b) $\frac{\partial^2 \phi}{\partial x_1^2} + \frac{\partial^2 \phi}{\partial x_2^2} + \frac{\partial^2 \phi}{\partial x_3^2} = 0$.
- 2.6 Given that $S_{ij} = a_i a_j$ and $S'_{ij} = a'_i a'_j$, where $a'_i = Q_{mi} a_m$ and $a'_j = Q_{nj} a_n$, and $Q_{ik} Q_{jk} = \delta_{ij}$, show that $S'_{ii} = S_{ii}$.
- 2.7 Write $a_i = \frac{\partial v_i}{\partial t} + v_j \frac{\partial v_i}{\partial x_j}$ in long form.
- 2.8 Given that $T_{ij} = 2\mu E_{ij} + \lambda E_{kk} \delta_{ij}$, show that
 (a) $T_{ij} E_{ij} = 2\mu E_{ij} E_{ij} + \lambda (E_{kk})^2$ and (b) $T_{ij} T_{ij} = 4\mu^2 E_{ij} E_{ij} + (E_{kk})^2 (4\mu\lambda + 3\lambda^2)$.
- 2.9 Given that $a_i = T_{ij} b_j$, and $a'_i = T'_{ij} b'_j$, where $a_i = Q_{im} a'_m$ and $T_{ij} = Q_{im} Q_{jn} T'_{mn}$,
 (a) show that $Q_{im} T'_{mn} b'_n = Q_{im} Q_{jn} T'_{mn} b_j$ and (b) if $Q_{ik} Q_{im} = \delta_{km}$, then $T'_{kn} (b'_n - Q_{jn} b_j) = 0$.
- 2.10 Given

$$[a_i] = \begin{bmatrix} 1 \\ 2 \\ 0 \end{bmatrix}, \quad [b_i] = \begin{bmatrix} 0 \\ 2 \\ 3 \end{bmatrix},$$

evaluate $[d_i]$, if $d_k = \varepsilon_{ijk} a_i b_j$, and show that this result is the same as $d_k = (\mathbf{a} \times \mathbf{b}) \cdot \mathbf{e}_k$.

- 2.11 (a) If $\varepsilon_{ijk} T_{ij} = 0$, show that $T_{ij} = T_{ji}$, and (b) show that $\delta_{ij} \varepsilon_{ijk} = 0$.
- 2.12 Verify the following equation: $\varepsilon_{ijm} \varepsilon_{klm} = \delta_{ik} \delta_{jl} - \delta_{il} \delta_{jk}$. *Hint:* There are six cases to be considered: (1) $i = j$, (2) $i = k$, (3) $i = l$, (4) $j = k$, (5) $j = l$, and (6) $k = l$.
- 2.13 Use the identity $\varepsilon_{ijm} \varepsilon_{klm} = \delta_{ik} \delta_{jl} - \delta_{il} \delta_{jk}$ as a shortcut to obtain the following results: (a) $\varepsilon_{ilm} \varepsilon_{jlm} = 2\delta_{ij}$ and (b) $\varepsilon_{ijk} \varepsilon_{ijk} = 6$.
- 2.14 Use the identity $\varepsilon_{ijm} \varepsilon_{klm} = \delta_{ik} \delta_{jl} - \delta_{il} \delta_{jk}$ to show that $\mathbf{a} \times (\mathbf{b} \times \mathbf{c}) = (\mathbf{a} \cdot \mathbf{c})\mathbf{b} - (\mathbf{a} \cdot \mathbf{b})\mathbf{c}$.
- 2.15 Show that (a) if $T_{ij} = -T_{ji}$, then $T_{ij} a_i a_j = 0$, (b) if $T_{ij} = -T_{ji}$, and $S_{ij} = S_{ji}$, then $T_{ij} S_{ij} = 0$.
- 2.16 Let $T_{ij} = \frac{1}{2}(S_{ij} + S_{ji})$ and $R_{ij} = \frac{1}{2}(S_{ij} - S_{ji})$, show that $T_{ij} = T_{ji}$, $R_{ij} = -R_{ji}$, and $S_{ij} = T_{ij} + R_{ij}$.
- 2.17 Let $f(x_1, x_2, x_3)$ be a function of x_1 , x_2 , and x_3 and let $v_i(x_1, x_2, x_3)$ be three functions of x_1 , x_2 , and x_3 . Express the total differential df and dv_i in indicial notation.
- 2.18 Let $|A_{ij}|$ denote the determinant of the matrix $[A_{ij}]$. Show that $|A_{ij}| = \varepsilon_{ijk} A_{i1} A_{j2} A_{k3}$.

PART B: TENSORS

2.6 TENSOR: A LINEAR TRANSFORMATION

Let \mathbf{T} be a transformation that transforms any vector into another vector. If \mathbf{T} transforms \mathbf{a} into \mathbf{c} and \mathbf{b} into \mathbf{d} , we write $\mathbf{T}\mathbf{a} = \mathbf{c}$ and $\mathbf{T}\mathbf{b} = \mathbf{d}$.

If \mathbf{T} has the following linear properties:

$$\mathbf{T}(\mathbf{a} + \mathbf{b}) = \mathbf{T}\mathbf{a} + \mathbf{T}\mathbf{b}, \quad (2.6.1)$$

$$\mathbf{T}(\alpha\mathbf{a}) = \alpha\mathbf{T}\mathbf{a}, \quad (2.6.2)$$

where \mathbf{a} and \mathbf{b} are two arbitrary vectors and α is an arbitrary scalar, then \mathbf{T} is called a *linear transformation*. It is also called a *second-order tensor* or simply a *tensor*.* An alternative and equivalent definition of a linear transformation is given by the single linear property:

$$\mathbf{T}(\alpha\mathbf{a} + \beta\mathbf{b}) = \alpha\mathbf{T}\mathbf{a} + \beta\mathbf{T}\mathbf{b}, \quad (2.6.3)$$

where \mathbf{a} and \mathbf{b} are two arbitrary vectors and α and β are arbitrary scalars. If two tensors, \mathbf{T} and \mathbf{S} , transform any arbitrary vector \mathbf{a} identically, these two tensors are the same, that is, if $\mathbf{T}\mathbf{a} = \mathbf{S}\mathbf{a}$ for any \mathbf{a} , then $\mathbf{T} = \mathbf{S}$. We note, however, that two different tensors may transform specific vectors identically.

Example 2.6.1

Let \mathbf{T} be a nonzero transformation that transforms every vector into a fixed nonzero vector \mathbf{n} . Is this transformation a tensor?

Solution

Let \mathbf{a} and \mathbf{b} be any two vectors; then $\mathbf{T}\mathbf{a} = \mathbf{n}$ and $\mathbf{T}\mathbf{b} = \mathbf{n}$. Since $\mathbf{a} + \mathbf{b}$ is also a vector, therefore $\mathbf{T}(\mathbf{a} + \mathbf{b}) = \mathbf{n}$. Clearly $\mathbf{T}(\mathbf{a} + \mathbf{b})$ does not equal $\mathbf{T}\mathbf{a} + \mathbf{T}\mathbf{b}$. Thus, this transformation is not a linear one. In other words, it is not a tensor.

Example 2.6.2

Let \mathbf{T} be a transformation that transforms every vector into a vector that is k times the original vector. Is this transformation a tensor?

Solution

Let \mathbf{a} and \mathbf{b} be arbitrary vectors and α and β be arbitrary scalars; then, by the definition of \mathbf{T} ,

$$\mathbf{T}\mathbf{a} = k\mathbf{a}, \quad \mathbf{T}\mathbf{b} = k\mathbf{b} \quad \text{and} \quad \mathbf{T}(\alpha\mathbf{a} + \beta\mathbf{b}) = k(\alpha\mathbf{a} + \beta\mathbf{b}). \quad (i)$$

Clearly,

$$\mathbf{T}(\alpha\mathbf{a} + \beta\mathbf{b}) = \alpha k\mathbf{a} + \beta k\mathbf{b} = \alpha\mathbf{T}\mathbf{a} + \beta\mathbf{T}\mathbf{b}. \quad (ii)$$

Therefore, \mathbf{T} is a linear transformation. In other words, it is a tensor. If $k = 0$, then the tensor transforms all vectors into a zero vector (null vector). This tensor is the *zero tensor* or *null tensor* and is symbolized by the boldface $\mathbf{0}$.

Example 2.6.3

Consider a transformation \mathbf{T} that transforms every vector into its mirror image with respect to a fixed plane. Is \mathbf{T} a tensor?

Solution

Consider a parallelogram in space with its sides representing vectors \mathbf{a} and \mathbf{b} and its diagonal the vector sum of \mathbf{a} and \mathbf{b} . Since the parallelogram remains a parallelogram after the reflection, the diagonal (the resultant vector)

*Scalars and vectors are sometimes called the *zeroth order tensor* and the *first-order tensor*, respectively. Even though they can also be defined algebraically, in terms of certain operational rules, we choose not to do so. The geometrical concept of scalars and vectors, with which we assume readers are familiar, is quite sufficient for our purpose.

of the reflected parallelogram is clearly both $\mathbf{T}(\mathbf{a} + \mathbf{b})$ (the reflected $\mathbf{a} + \mathbf{b}$) and $\mathbf{T}\mathbf{a} + \mathbf{T}\mathbf{b}$ (the sum of the reflected \mathbf{a} and the reflected \mathbf{b}). That is, $\mathbf{T}(\mathbf{a} + \mathbf{b}) = \mathbf{T}\mathbf{a} + \mathbf{T}\mathbf{b}$. Also, for an arbitrary scalar α , the reflection of $\alpha\mathbf{a}$ is obviously the same as α times the reflection of \mathbf{a} , that is, $\mathbf{T}(\alpha\mathbf{a}) = \alpha(\mathbf{T}\mathbf{a})$, because both vectors have the same magnitude given by α times the magnitude of \mathbf{a} and in the same direction. Thus, \mathbf{T} is a tensor.

Example 2.6.4

When a rigid body undergoes a rotation about some axis \mathbf{n} , vectors drawn in the rigid body in general change their directions. That is, the rotation transforms vectors drawn in the rigid body into other vectors. Denote this transformation by \mathbf{R} . Is \mathbf{R} a tensor?

Solution

Consider a parallelogram embedded in the rigid body with its sides representing vectors \mathbf{a} and \mathbf{b} and its diagonal representing the resultant $(\mathbf{a} + \mathbf{b})$. Since the parallelogram remains a parallelogram after a rotation about any axis, the diagonal (the resultant vector) of the rotated parallelogram is clearly both $\mathbf{R}(\mathbf{a} + \mathbf{b})$ (the rotated $\mathbf{a} + \mathbf{b}$) and $\mathbf{R}\mathbf{a} + \mathbf{R}\mathbf{b}$ (the sum of the rotated \mathbf{a} and the rotated \mathbf{b}). That is, $\mathbf{R}(\mathbf{a} + \mathbf{b}) = \mathbf{R}\mathbf{a} + \mathbf{R}\mathbf{b}$. A similar argument as that used in the previous example leads to $\mathbf{R}(\alpha\mathbf{a}) = \alpha(\mathbf{R}\mathbf{a})$. Thus, \mathbf{R} is a tensor.

Example 2.6.5

Let \mathbf{T} be a tensor that transforms the specific vectors \mathbf{a} and \mathbf{b} as follows:

$$\begin{aligned}\mathbf{T}\mathbf{a} &= \mathbf{a} + 2\mathbf{b}, \\ \mathbf{T}\mathbf{b} &= \mathbf{a} - \mathbf{b}.\end{aligned}$$

Given a vector $\mathbf{c} = 2\mathbf{a} + \mathbf{b}$, find $\mathbf{T}\mathbf{c}$.

Solution

Using the linearity property of tensors, we have

$$\mathbf{T}\mathbf{c} = \mathbf{T}(2\mathbf{a} + \mathbf{b}) = 2\mathbf{T}\mathbf{a} + \mathbf{T}\mathbf{b} = 2(\mathbf{a} + 2\mathbf{b}) + (\mathbf{a} - \mathbf{b}) = 3\mathbf{a} + 3\mathbf{b}.$$

2.7 COMPONENTS OF A TENSOR

The components of a vector depend on the base vectors used to describe the components. This will also be true for tensors.

Let $\mathbf{e}_1, \mathbf{e}_2, \mathbf{e}_3$ be unit vectors in the direction of the x_1, x_2, x_3 , respectively, of a rectangular Cartesian coordinate system. Under a transformation \mathbf{T} , these vectors $\mathbf{e}_1, \mathbf{e}_2, \mathbf{e}_3$ become $\mathbf{T}\mathbf{e}_1, \mathbf{T}\mathbf{e}_2, \mathbf{T}\mathbf{e}_3$. Each of these $\mathbf{T}\mathbf{e}_i$, being a vector, can be written as:

$$\begin{aligned}\mathbf{T}\mathbf{e}_1 &= T_{11}\mathbf{e}_1 + T_{21}\mathbf{e}_2 + T_{31}\mathbf{e}_3, \\ \mathbf{T}\mathbf{e}_2 &= T_{12}\mathbf{e}_1 + T_{22}\mathbf{e}_2 + T_{32}\mathbf{e}_3, \\ \mathbf{T}\mathbf{e}_3 &= T_{13}\mathbf{e}_1 + T_{23}\mathbf{e}_2 + T_{33}\mathbf{e}_3,\end{aligned}\tag{2.7.1}$$

or

$$\mathbf{T}\mathbf{e}_i = T_{ji}\mathbf{e}_j.\tag{2.7.2}$$

The components T_{ij} in the preceding equations are defined as the components of the tensor \mathbf{T} . These components can be put in a matrix as follows:

$$[\mathbf{T}] = \begin{bmatrix} T_{11} & T_{12} & T_{13} \\ T_{21} & T_{22} & T_{23} \\ T_{31} & T_{32} & T_{33} \end{bmatrix}. \quad (2.7.3)$$

This matrix is called the *matrix of the tensor* \mathbf{T} with respect to the set of base vectors $\{\mathbf{e}_i\}$. We note that, because of the way we have chosen to denote the components of transformation of the base vectors, the elements of the first column in the matrix are components of the vector $\mathbf{T}\mathbf{e}_1$, those in the second column are the components of the vector $\mathbf{T}\mathbf{e}_2$, and those in the third column are the components of $\mathbf{T}\mathbf{e}_3$.

Example 2.7.1

Obtain the matrix for the tensor \mathbf{T} that transforms the base vectors as follows:

$$\begin{aligned} \mathbf{T}\mathbf{e}_1 &= 4\mathbf{e}_1 + \mathbf{e}_2, \\ \mathbf{T}\mathbf{e}_2 &= 2\mathbf{e}_1 + 3\mathbf{e}_3, \\ \mathbf{T}\mathbf{e}_3 &= -\mathbf{e}_1 + 3\mathbf{e}_2 + \mathbf{e}_3. \end{aligned} \quad (i)$$

Solution

By Eq. (2.7.1),

$$[\mathbf{T}] = \begin{bmatrix} 4 & 2 & -1 \\ 1 & 0 & 3 \\ 0 & 3 & 1 \end{bmatrix}. \quad (ii)$$

Example 2.7.2

Let \mathbf{T} transform every vector into its mirror image with respect to a fixed plane; if \mathbf{e}_1 is normal to the reflection plane (\mathbf{e}_2 and \mathbf{e}_3 are parallel to this plane), find a matrix of \mathbf{T} .

Solution

Since the normal to the reflection plane is transformed into its negative and vectors parallel to the plane are not altered, we have

$$\mathbf{T}\mathbf{e}_1 = -\mathbf{e}_1, \quad \mathbf{T}\mathbf{e}_2 = \mathbf{e}_2, \quad \mathbf{T}\mathbf{e}_3 = \mathbf{e}_3$$

which corresponds to

$$[\mathbf{T}] = \begin{bmatrix} -1 & 0 & 0 \\ 0 & 1 & 0 \\ 0 & 0 & 1 \end{bmatrix}_{\mathbf{e}_i}$$

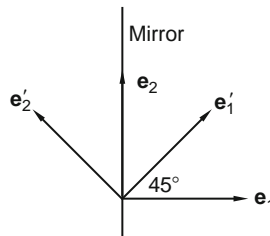

FIGURE 2.7-1

We note that this is only one of the infinitely many matrices of the tensor \mathbf{T} ; each depends on a particular choice of base vectors. In the preceding matrix, the choice of \mathbf{e}_i is indicated at the bottom-right corner of the matrix. If we choose \mathbf{e}'_1 and \mathbf{e}'_2 to be on a plane perpendicular to the mirror, with each making 45° with the mirror, as shown in Figure 2.7-1, and \mathbf{e}'_3 pointing straight out from the paper, then we have

$$\mathbf{T}\mathbf{e}'_1 = \mathbf{e}'_2, \quad \mathbf{T}\mathbf{e}'_2 = \mathbf{e}'_1, \quad \mathbf{T}\mathbf{e}'_3 = \mathbf{e}'_3.$$

Thus, with respect to $\{\mathbf{e}'_i\}$, the matrix of the tensor is

$$[\mathbf{T}]' = \begin{bmatrix} 0 & 1 & 0 \\ 1 & 0 & 0 \\ 0 & 0 & 1 \end{bmatrix}_{\mathbf{e}'_i}.$$

Throughout this book, we denote the matrix of a tensor \mathbf{T} with respect to the basis $\{\mathbf{e}_i\}$ by either $[\mathbf{T}]$ or $[T_{ij}]$ and with respect to the basis $\{\mathbf{e}'_i\}$ by either $[\mathbf{T}]'$ or $[T'_{ij}]$. The last two matrices should not be confused with $[\mathbf{T}']$, which represents the matrix of the tensor \mathbf{T}' with respect to the basis $\{\mathbf{e}_i\}$, not the matrix of \mathbf{T} with respect to the primed basis $\{\mathbf{e}'_i\}$.

Example 2.7.3

Let \mathbf{R} correspond to a right-hand rotation of a rigid body about the x_3 -axis by an angle θ (Figure 2.7-2). Find a matrix of \mathbf{R} .

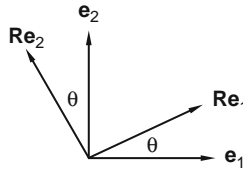

FIGURE 2.7-2

Solution

From Figure 2.7-2, it is clear that

$$\begin{aligned} \mathbf{Re}_1 &= \cos\theta\mathbf{e}_1 + \sin\theta\mathbf{e}_2, \\ \mathbf{Re}_2 &= -\sin\theta\mathbf{e}_1 + \cos\theta\mathbf{e}_2, \\ \mathbf{Re}_3 &= \mathbf{e}_3. \end{aligned}$$

which corresponds to

$$[\mathbf{R}] = \begin{bmatrix} \cos\theta & -\sin\theta & 0 \\ \sin\theta & \cos\theta & 0 \\ 0 & 0 & 1 \end{bmatrix}_{\mathbf{e}_i}.$$

Example 2.7.4

Obtain the matrix for the tensor \mathbf{T} , which transforms the base vectors as follows:

$$\begin{aligned}\mathbf{T}\mathbf{e}_1 &= \mathbf{e}_1 + 2\mathbf{e}_2 + 3\mathbf{e}_3, \\ \mathbf{T}\mathbf{e}_2 &= 4\mathbf{e}_1 + 5\mathbf{e}_2 + 6\mathbf{e}_3, \\ \mathbf{T}\mathbf{e}_3 &= 7\mathbf{e}_1 + 8\mathbf{e}_2 + 9\mathbf{e}_3.\end{aligned}$$

Solution

By inspection,

$$[\mathbf{T}] = \begin{bmatrix} 1 & 4 & 7 \\ 2 & 5 & 8 \\ 3 & 6 & 9 \end{bmatrix}.$$

This example emphasizes again the convention we use to write the matrix of a tensor: The components of $\mathbf{T}\mathbf{e}_1$ fill the first column, the components of $\mathbf{T}\mathbf{e}_2$ fill the second column, and so on. The reason for this choice of convention will become obvious in the next section.

Since $\mathbf{e}_1 \cdot \mathbf{e}_2 = \mathbf{e}_2 \cdot \mathbf{e}_3 = \mathbf{e}_3 \cdot \mathbf{e}_1 = 0$ (because they are mutually perpendicular), it can be easily verified from Eq. (2.7.1) that

$$\begin{aligned}T_{11} &= \mathbf{e}_1 \cdot \mathbf{T}\mathbf{e}_1, & T_{12} &= \mathbf{e}_1 \cdot \mathbf{T}\mathbf{e}_2, & T_{13} &= \mathbf{e}_1 \cdot \mathbf{T}\mathbf{e}_3, \\ T_{21} &= \mathbf{e}_2 \cdot \mathbf{T}\mathbf{e}_1, & T_{22} &= \mathbf{e}_2 \cdot \mathbf{T}\mathbf{e}_2, & T_{23} &= \mathbf{e}_2 \cdot \mathbf{T}\mathbf{e}_3, \\ T_{31} &= \mathbf{e}_3 \cdot \mathbf{T}\mathbf{e}_1, & T_{32} &= \mathbf{e}_3 \cdot \mathbf{T}\mathbf{e}_2, & T_{33} &= \mathbf{e}_3 \cdot \mathbf{T}\mathbf{e}_3,\end{aligned}\tag{2.7.4}$$

or

$$T_{ij} = \mathbf{e}_i \cdot \mathbf{T}\mathbf{e}_j.\tag{2.7.5}$$

These equations are totally equivalent to Eq. (2.7.1) [or Eq. (2.7.2)] and can also be regarded as the definition of the components of a tensor \mathbf{T} . They are often more convenient to use than Eq. (2.7.2).

We note again that the components of a tensor depend on the coordinate systems through the set of base vectors. Thus,

$$T'_{ij} = \mathbf{e}'_i \cdot \mathbf{T}\mathbf{e}'_j,\tag{2.7.6}$$

where T'_{ij} are the components of the same tensor \mathbf{T} with respect to the base vectors $\{\mathbf{e}'_i\}$. It is important to note that vectors and tensors are independent of coordinate systems, but *their components* are dependent on the coordinate systems.

2.8 COMPONENTS OF A TRANSFORMED VECTOR

Given the vector \mathbf{a} and the tensor \mathbf{T} , which transforms \mathbf{a} into \mathbf{b} (i.e., $\mathbf{b} = \mathbf{T}\mathbf{a}$), we wish to compute the components of \mathbf{b} from the components of \mathbf{a} and the components of \mathbf{T} . Let the components of \mathbf{a} with respect to $\{\mathbf{e}_1, \mathbf{e}_2, \mathbf{e}_3\}$ be (a_1, a_2, a_3) , that is,

$$\mathbf{a} = a_1\mathbf{e}_1 + a_2\mathbf{e}_2 + a_3\mathbf{e}_3,\tag{2.8.1}$$

then

$$\mathbf{b} = \mathbf{Ta} = \mathbf{T}(a_1\mathbf{e}_1 + a_2\mathbf{e}_2 + a_3\mathbf{e}_3) = a_1\mathbf{Te}_1 + a_2\mathbf{Te}_2 + a_3\mathbf{Te}_3,$$

thus,

$$\begin{aligned} b_1 &= \mathbf{b} \cdot \mathbf{e}_1 = \mathbf{e}_1 \cdot \mathbf{T}(a_1\mathbf{e}_1 + a_2\mathbf{e}_2 + a_3\mathbf{e}_3) = a_1(\mathbf{e}_1 \cdot \mathbf{Te}_1) + a_2(\mathbf{e}_1 \cdot \mathbf{Te}_2) + a_3(\mathbf{e}_1 \cdot \mathbf{Te}_3), \\ b_2 &= \mathbf{b} \cdot \mathbf{e}_2 = \mathbf{e}_2 \cdot \mathbf{T}(a_1\mathbf{e}_1 + a_2\mathbf{e}_2 + a_3\mathbf{e}_3) = a_1(\mathbf{e}_2 \cdot \mathbf{Te}_1) + a_2(\mathbf{e}_2 \cdot \mathbf{Te}_2) + a_3(\mathbf{e}_2 \cdot \mathbf{Te}_3), \\ b_3 &= \mathbf{b} \cdot \mathbf{e}_3 = \mathbf{e}_3 \cdot \mathbf{T}(a_1\mathbf{e}_1 + a_2\mathbf{e}_2 + a_3\mathbf{e}_3) = a_1(\mathbf{e}_3 \cdot \mathbf{Te}_1) + a_2(\mathbf{e}_3 \cdot \mathbf{Te}_2) + a_3(\mathbf{e}_3 \cdot \mathbf{Te}_3). \end{aligned}$$

By Eqs. (2.7.4), we have

$$\begin{aligned} b_1 &= T_{11}a_1 + T_{12}a_2 + T_{13}a_3, \\ b_2 &= T_{21}a_1 + T_{22}a_2 + T_{23}a_3, \\ b_3 &= T_{31}a_1 + T_{32}a_2 + T_{33}a_3. \end{aligned} \quad (2.8.2)$$

We can write the preceding three equations in matrix form as:

$$\begin{bmatrix} b_1 \\ b_2 \\ b_3 \end{bmatrix} = \begin{bmatrix} T_{11} & T_{12} & T_{13} \\ T_{21} & T_{22} & T_{23} \\ T_{31} & T_{32} & T_{33} \end{bmatrix} \begin{bmatrix} a_1 \\ a_2 \\ a_3 \end{bmatrix}, \quad (2.8.3)$$

or

$$[\mathbf{b}] = [\mathbf{T}][\mathbf{a}]. \quad (2.8.4)$$

We can also derive Eq. (2.8.2) using indicial notations as follows: From $\mathbf{a} = a_i\mathbf{e}_i$, we get $\mathbf{Ta} = \mathbf{T}(a_i\mathbf{e}_i) = a_i\mathbf{Te}_i$. Since $\mathbf{Te}_i = T_{ji}\mathbf{e}_j$ [Eq. (2.7.2)], $\mathbf{b} = \mathbf{Ta} = a_iT_{ji}\mathbf{e}_j$ so that

$$b_m = \mathbf{b} \cdot \mathbf{e}_m = a_iT_{ji}\mathbf{e}_j \cdot \mathbf{e}_m = a_iT_{ji}\delta_{jm} = a_iT_{mi},$$

that is,

$$b_m = a_iT_{mi} = T_{mi}a_i. \quad (2.8.5)$$

Eq. (2.8.5) is nothing but Eq. (2.8.2) in indicial notation.

We see that for the tensorial equation $\mathbf{b} = \mathbf{Ta}$, there corresponds a matrix equation of exactly the same form, that is, $[\mathbf{b}] = [\mathbf{T}][\mathbf{a}]$. This is the reason we adopted the convention that $\mathbf{Te}_i = T_{ji}\mathbf{e}_j$ (i.e., $\mathbf{Te}_1 = T_{11}\mathbf{e}_1 + T_{21}\mathbf{e}_2 + T_{31}\mathbf{e}_3$, etc.). If we had adopted the convention that $\mathbf{Te}_i = T_{ij}\mathbf{e}_j$ (i.e., $\mathbf{Te}_1 = T_{11}\mathbf{e}_1 + T_{12}\mathbf{e}_2 + T_{13}\mathbf{e}_3$, etc.), then we would have obtained $[\mathbf{b}] = [\mathbf{T}]^T[\mathbf{a}]$ for the tensorial equation $\mathbf{b} = \mathbf{Ta}$, which would not be as natural.

Example 2.8.1

Given that a tensor \mathbf{T} transforms the base vectors as follows:

$$\begin{aligned} \mathbf{Te}_1 &= 2\mathbf{e}_1 - 6\mathbf{e}_2 + 4\mathbf{e}_3, \\ \mathbf{Te}_2 &= 3\mathbf{e}_1 + 4\mathbf{e}_2 - 1\mathbf{e}_3, \\ \mathbf{Te}_3 &= -2\mathbf{e}_1 + 1\mathbf{e}_2 + 2\mathbf{e}_3. \end{aligned}$$

how does this tensor transform the vector $\mathbf{a} = \mathbf{e}_1 + 2\mathbf{e}_2 + 3\mathbf{e}_3$?

Solution

Use the matrix equation

$$\begin{bmatrix} b_1 \\ b_2 \\ b_3 \end{bmatrix} = \begin{bmatrix} 2 & 3 & -2 \\ -6 & 4 & 1 \\ 4 & -1 & 2 \end{bmatrix} \begin{bmatrix} 1 \\ 2 \\ 3 \end{bmatrix} = \begin{bmatrix} 2 \\ 5 \\ 8 \end{bmatrix},$$

we obtain $\mathbf{b} = 2\mathbf{e}_1 + 5\mathbf{e}_2 + 8\mathbf{e}_3$.

2.9 SUM OF TENSORS

Let \mathbf{T} and \mathbf{S} be two tensors. The sum of \mathbf{T} and \mathbf{S} , denoted by $\mathbf{T} + \mathbf{S}$, is defined by

$$(\mathbf{T} + \mathbf{S})\mathbf{a} = \mathbf{T}\mathbf{a} + \mathbf{S}\mathbf{a} \quad (2.9.1)$$

for any vector \mathbf{a} . It is easily seen that $\mathbf{T} + \mathbf{S}$, so defined, is indeed a tensor. To find the components of $\mathbf{T} + \mathbf{S}$, let

$$\mathbf{W} = \mathbf{T} + \mathbf{S}. \quad (2.9.2)$$

The components of \mathbf{W} are [see Eqs. (2.7.5)]

$$W_{ij} = \mathbf{e}_i \cdot (\mathbf{T} + \mathbf{S})\mathbf{e}_j = \mathbf{e}_i \cdot \mathbf{T}\mathbf{e}_j + \mathbf{e}_i \cdot \mathbf{S}\mathbf{e}_j,$$

that is,

$$W_{ij} = T_{ij} + S_{ij}. \quad (2.9.3)$$

In matrix notation, we have

$$[\mathbf{W}] = [\mathbf{T}] + [\mathbf{S}], \quad (2.9.4)$$

and that the tensor sum is consistent with the matrix sum.

2.10 PRODUCT OF TWO TENSORS

Let \mathbf{T} and \mathbf{S} be two tensors and \mathbf{a} be an arbitrary vector. Then \mathbf{TS} and \mathbf{ST} are defined to be the transformations (easily seen to be tensors) such that

$$(\mathbf{TS})\mathbf{a} = \mathbf{T}(\mathbf{S}\mathbf{a}), \quad (2.10.1)$$

and

$$(\mathbf{ST})\mathbf{a} = \mathbf{S}(\mathbf{T}\mathbf{a}). \quad (2.10.2)$$

The components of \mathbf{TS} are

$$(\mathbf{TS})_{ij} = \mathbf{e}_i \cdot (\mathbf{TS})\mathbf{e}_j = \mathbf{e}_i \cdot \mathbf{T}(\mathbf{S}\mathbf{e}_j) = \mathbf{e}_i \cdot \mathbf{T}S_{mj}\mathbf{e}_m = S_{mj}\mathbf{e}_i \cdot \mathbf{T}\mathbf{e}_m = S_{mj}T_{im}, \quad (2.10.3)$$

that is,

$$(\mathbf{TS})_{ij} = T_{im}S_{mj}. \quad (2.10.4)$$

Similarly,

$$(\mathbf{ST})_{ij} = S_{im}T_{mj}. \quad (2.10.5)$$

Eq. (2.10.4) is equivalent to the matrix equation:

$$[\mathbf{TS}] = [\mathbf{T}][\mathbf{S}], \tag{2.10.6}$$

whereas Eq. (2.10.5) is equivalent to the matrix equation:

$$[\mathbf{ST}] = [\mathbf{S}][\mathbf{T}]. \tag{2.10.7}$$

The two products are, in general, different. Thus, it is clear that in general $\mathbf{TS} \neq \mathbf{ST}$. That is, in general, the tensor product is not commutative.

If \mathbf{T} , \mathbf{S} , and \mathbf{V} are three tensors, then, by repeatedly using the definition (2.10.1), we have

$$(\mathbf{T}(\mathbf{SV}))\mathbf{a} \equiv \mathbf{T}((\mathbf{SV})\mathbf{a}) \equiv \mathbf{T}(\mathbf{S}(\mathbf{V}\mathbf{a})) \quad \text{and} \quad (\mathbf{TS})(\mathbf{V}\mathbf{a}) \equiv \mathbf{T}(\mathbf{S}(\mathbf{V}\mathbf{a})), \tag{2.10.8}$$

that is,

$$\mathbf{T}(\mathbf{SV}) = (\mathbf{TS})\mathbf{V} = \mathbf{TSV}. \tag{2.10.9}$$

Thus, the tensor product is associative. It is, therefore, natural to define the integral positive powers of a tensor by these simple products, so that

$$\mathbf{T}^2 = \mathbf{TT}, \quad \mathbf{T}^3 = \mathbf{TTT}, \dots \tag{2.10.10}$$

Example 2.10.1

- (a) Let \mathbf{R} correspond to a 90° right-hand rigid body rotation about the x_3 -axis. Find the matrix of \mathbf{R} .
- (b) Let \mathbf{S} correspond to a 90° right-hand rigid body rotation about the x_1 -axis. Find the matrix of \mathbf{S} .
- (c) Find the matrix of the tensor that corresponds to the rotation \mathbf{R} , followed by \mathbf{S} .
- (d) Find the matrix of the tensor that corresponds to the rotation \mathbf{S} , followed by \mathbf{R} .
- (e) Consider a point P whose initial coordinates are $(1,1,0)$. Find the new position of this point after the rotations of part (c). Also find the new position of this point after the rotations of part (d).

Solution

- (a) Let $\{\mathbf{e}_1, \mathbf{e}_2, \mathbf{e}_3\}$ be a set of right-handed unit base vector with \mathbf{e}_3 along the axis of rotation of the rigid body. Then,

$$\mathbf{R}\mathbf{e}_1 = \mathbf{e}_2, \quad \mathbf{R}\mathbf{e}_2 = -\mathbf{e}_1, \quad \mathbf{R}\mathbf{e}_3 = \mathbf{e}_3,$$

that is,

$$[\mathbf{R}] = \begin{bmatrix} 0 & -1 & 0 \\ 1 & 0 & 0 \\ 0 & 0 & 1 \end{bmatrix}.$$

- (b) In a manner similar to (a), the transformation of the base vectors is given by:

$$\mathbf{S}\mathbf{e}_1 = \mathbf{e}_1, \quad \mathbf{S}\mathbf{e}_2 = \mathbf{e}_3, \quad \mathbf{S}\mathbf{e}_3 = -\mathbf{e}_2,$$

that is,

$$[\mathbf{S}] = \begin{bmatrix} 1 & 0 & 0 \\ 0 & 0 & -1 \\ 0 & 1 & 0 \end{bmatrix}.$$

- (c) Since $\mathbf{S}(\mathbf{R}\mathbf{a}) = (\mathbf{S}\mathbf{R})\mathbf{a}$, the resultant rotation is given by the single transformation $\mathbf{S}\mathbf{R}$ whose components are given by the matrix:

$$[\mathbf{S}\mathbf{R}] = \begin{bmatrix} 1 & 0 & 0 \\ 0 & 0 & -1 \\ 0 & 1 & 0 \end{bmatrix} \begin{bmatrix} 0 & -1 & 0 \\ 1 & 0 & 0 \\ 0 & 0 & 1 \end{bmatrix} = \begin{bmatrix} 0 & -1 & 0 \\ 0 & 0 & -1 \\ 1 & 0 & 0 \end{bmatrix}.$$

- (d) In a manner similar to (c), the resultant rotation is given by the single transformation $\mathbf{R}\mathbf{S}$ whose components are given by the matrix:

$$[\mathbf{R}\mathbf{S}] = \begin{bmatrix} 0 & -1 & 0 \\ 1 & 0 & 0 \\ 0 & 0 & 1 \end{bmatrix} \begin{bmatrix} 1 & 0 & 0 \\ 0 & 0 & -1 \\ 0 & 1 & 0 \end{bmatrix} = \begin{bmatrix} 0 & 0 & 1 \\ 1 & 0 & 0 \\ 0 & 1 & 0 \end{bmatrix}.$$

- (e) Let \mathbf{r} be the initial position of the material point P . Let \mathbf{r}^* and \mathbf{r}^{**} be the rotated position of P after the rotations of part (c) and part (d), respectively. Then

$$[\mathbf{r}^*] = [\mathbf{S}\mathbf{R}][\mathbf{r}] = \begin{bmatrix} 0 & -1 & 0 \\ 0 & 0 & -1 \\ 1 & 0 & 0 \end{bmatrix} \begin{bmatrix} 1 \\ 1 \\ 0 \end{bmatrix} = \begin{bmatrix} -1 \\ 0 \\ 1 \end{bmatrix},$$

that is,

$$\mathbf{r}^* = -\mathbf{e}_1 + \mathbf{e}_3,$$

and

$$[\mathbf{r}^{**}] = [\mathbf{R}\mathbf{S}][\mathbf{r}] = \begin{bmatrix} 0 & 0 & 1 \\ 1 & 0 & 0 \\ 0 & 1 & 0 \end{bmatrix} \begin{bmatrix} 1 \\ 1 \\ 0 \end{bmatrix} = \begin{bmatrix} 0 \\ 1 \\ 1 \end{bmatrix},$$

that is,

$$\mathbf{r}^{**} = \mathbf{e}_2 + \mathbf{e}_3.$$

This example further illustrates that the order of rotations is significant.

2.11 TRANSPOSE OF A TENSOR

The transpose of a tensor \mathbf{T} , denoted by \mathbf{T}^T , is defined to be the tensor that satisfies the following identity for all vectors \mathbf{a} and \mathbf{b} :

$$\mathbf{a} \cdot \mathbf{T}\mathbf{b} = \mathbf{b} \cdot \mathbf{T}^T\mathbf{a}. \quad (2.11.1)$$

It can be easily seen that \mathbf{T}^T is a tensor (see Prob. 2.34). From the preceding definition, we have

$$\mathbf{e}_j \cdot \mathbf{T}\mathbf{e}_i = \mathbf{e}_i \cdot \mathbf{T}^T\mathbf{e}_j. \quad (2.11.2)$$

Thus,

$$T_{ji} = T_{ij}^T, \quad (2.11.3)$$

or

$$[\mathbf{T}]^T = [\mathbf{T}^T], \quad (2.11.4)$$

that is, the matrix of \mathbf{T}^T is the transpose of the matrix \mathbf{T} . We also note that by Eq. (2.11.1), we have

$$\mathbf{a} \cdot \mathbf{T}^T \mathbf{b} = \mathbf{b} \cdot (\mathbf{T}^T)^T \mathbf{a}. \quad (2.11.5)$$

Thus, $\mathbf{b} \cdot \mathbf{T} \mathbf{a} = \mathbf{b} \cdot (\mathbf{T}^T)^T \mathbf{a}$ for any \mathbf{a} and \mathbf{b} , so that

$$(\mathbf{T}^T)^T = \mathbf{T}. \quad (2.11.6)$$

It can be easily established that (see Prob. 2.34)

$$(\mathbf{TS})^T = \mathbf{S}^T \mathbf{T}^T. \quad (2.11.7)$$

That is, the transpose of a product of the tensors is equal to the product of transposed tensors in reverse order, which is consistent with the equivalent matrix identity. More generally,

$$(\mathbf{ABC} \dots \mathbf{D})^T = \mathbf{D}^T \dots \mathbf{C}^T \mathbf{B}^T \mathbf{A}^T. \quad (2.11.8)$$

2.12 DYADIC PRODUCT OF VECTORS

The dyadic product of vectors \mathbf{a} and \mathbf{b} , denoted* by \mathbf{ab} , is defined to be the transformation that transforms any vector \mathbf{c} according to the rule:

$$(\mathbf{ab})\mathbf{c} = \mathbf{a}(\mathbf{b} \cdot \mathbf{c}). \quad (2.12.1)$$

Now, for any vectors \mathbf{c} , \mathbf{d} , and any scalars α and β , we have, from the preceding rule,

$$\begin{aligned} (\mathbf{ab})(\alpha\mathbf{c} + \beta\mathbf{d}) &= \mathbf{a}(\mathbf{b} \cdot (\alpha\mathbf{c} + \beta\mathbf{d})) = \mathbf{a}((\alpha\mathbf{b} \cdot \mathbf{c}) + (\beta\mathbf{b} \cdot \mathbf{d})) = \alpha\mathbf{a}(\mathbf{b} \cdot \mathbf{c}) + \beta\mathbf{a}(\mathbf{b} \cdot \mathbf{d}) \\ &= \alpha(\mathbf{ab})\mathbf{c} + \beta(\mathbf{ab})\mathbf{d}. \end{aligned} \quad (2.12.2)$$

Thus, the dyadic product \mathbf{ab} is a linear transformation.

Let $\mathbf{W} = \mathbf{ab}$, then the components of \mathbf{W} are:

$$W_{ij} = \mathbf{e}_i \cdot \mathbf{W} \mathbf{e}_j = \mathbf{e}_i \cdot (\mathbf{ab})\mathbf{e}_j = \mathbf{e}_i \cdot \mathbf{a}(\mathbf{b} \cdot \mathbf{e}_j) = a_i b_j, \quad (2.12.3)$$

that is,

$$W_{ij} = a_i b_j, \quad (2.12.4)$$

or

$$[\mathbf{W}] = \begin{bmatrix} a_1 b_1 & a_1 b_2 & a_1 b_3 \\ a_2 b_1 & a_2 b_2 & a_2 b_3 \\ a_3 b_1 & a_3 b_2 & a_3 b_3 \end{bmatrix} = \begin{bmatrix} a_1 \\ a_2 \\ a_3 \end{bmatrix} [b_1 \quad b_2 \quad b_3]. \quad (2.12.5)$$

In particular, the dyadic products of the base vectors \mathbf{e}_i are:

$$[\mathbf{e}_1 \mathbf{e}_1] = \begin{bmatrix} 1 & 0 & 0 \\ 0 & 0 & 0 \\ 0 & 0 & 0 \end{bmatrix}, \quad [\mathbf{e}_1 \mathbf{e}_2] = \begin{bmatrix} 0 & 1 & 0 \\ 0 & 0 & 0 \\ 0 & 0 & 0 \end{bmatrix} \dots \quad (2.12.6)$$

*Some authors write $\mathbf{a} \otimes \mathbf{b}$ for \mathbf{ab} . Also, some authors write $(\mathbf{ab}) \cdot \mathbf{c}$ for $(\mathbf{ab})\mathbf{c}$ and $\mathbf{c} \cdot (\mathbf{ab})$ for $(\mathbf{ab})^T \mathbf{c}$.

Thus, it is clear that any tensor \mathbf{T} can be expressed as:

$$\mathbf{T} = T_{11}\mathbf{e}_1\mathbf{e}_1 + T_{12}\mathbf{e}_1\mathbf{e}_2 + T_{13}\mathbf{e}_1\mathbf{e}_3 + T_{21}\mathbf{e}_2\mathbf{e}_1 + \dots = T_{ij}\mathbf{e}_i\mathbf{e}_j. \quad (2.12.7)$$

2.13 TRACE OF A TENSOR

The *trace* of a tensor is a scalar that obeys the following rules: For any tensor \mathbf{T} and \mathbf{S} and any vectors \mathbf{a} and \mathbf{b} ,

$$\begin{aligned} \text{tr}(\mathbf{T} + \mathbf{S}) &= \text{tr } \mathbf{T} + \text{tr } \mathbf{S}, \\ \text{tr}(\alpha \mathbf{T}) &= \alpha \text{tr } \mathbf{T}, \\ \text{tr}(\mathbf{ab}) &= \mathbf{a} \cdot \mathbf{b}. \end{aligned} \quad (2.13.1)$$

In terms of tensor components, using Eq. (2.12.7),

$$\text{tr } \mathbf{T} = \text{tr}(T_{ij}\mathbf{e}_i\mathbf{e}_j) = T_{ij}\text{tr}(\mathbf{e}_i\mathbf{e}_j) = T_{ij}\mathbf{e}_i \cdot \mathbf{e}_j = T_{ij}\delta_{ij} = T_{ii}. \quad (2.13.2)$$

That is,

$$\text{tr } \mathbf{T} = T_{11} + T_{22} + T_{33} = \text{sum of diagonal elements.} \quad (2.13.3)$$

It is, therefore, obvious that

$$\text{tr } \mathbf{T}^T = \text{tr } \mathbf{T}. \quad (2.13.4)$$

Example 2.13.1

Show that for any second-order tensor \mathbf{A} and \mathbf{B}

$$\text{tr}(\mathbf{AB}) = \text{tr}(\mathbf{BA}). \quad (2.13.5)$$

Solution

Let $\mathbf{C} = \mathbf{AB}$, then $C_{ij} = A_{im}B_{mj}$, so that $\text{tr}(\mathbf{AB}) = \text{tr } \mathbf{C} = C_{ij} = A_{im}B_{mi}$.

Let $\mathbf{D} = \mathbf{BA}$, then $D_{ij} = B_{im}A_{mj}$, so that $\text{tr}(\mathbf{BA}) = \text{tr } \mathbf{D} = D_{ij} = B_{im}A_{mi}$. But $B_{im}A_{mi} = B_{mi}A_{im}$ (change of dummy indices); therefore, we have the desired result

$$\text{tr}(\mathbf{AB}) = \text{tr}(\mathbf{BA}).$$

2.14 IDENTITY TENSOR AND TENSOR INVERSE

The linear transformation that transforms every vector into itself is called an *identity tensor*. Denoting this special tensor by \mathbf{I} , we have for any vector \mathbf{a} ,

$$\mathbf{Ia} = \mathbf{a}. \quad (2.14.1)$$

In particular,

$$\mathbf{Ie}_1 = \mathbf{e}_1, \quad \mathbf{Ie}_2 = \mathbf{e}_2, \quad \mathbf{Ie}_3 = \mathbf{e}_3. \quad (2.14.2)$$

Thus the (Cartesian) components of the identity tensor are:

$$I_{ij} = \mathbf{e}_i \cdot \mathbf{I} \mathbf{e}_j = \mathbf{e}_i \cdot \mathbf{e}_j = \delta_{ij}, \quad (2.14.3)$$

that is,

$$[\mathbf{I}] = \begin{bmatrix} 1 & 0 & 0 \\ 0 & 1 & 0 \\ 0 & 0 & 1 \end{bmatrix}. \quad (2.14.4)$$

It is obvious that the identity matrix is the matrix of \mathbf{I} for *all rectangular Cartesian coordinates* and that $\mathbf{T}\mathbf{I} = \mathbf{I}\mathbf{T} = \mathbf{T}$ for any tensor \mathbf{T} . We also note that if $\mathbf{T}\mathbf{a} = \mathbf{a}$ for any arbitrary \mathbf{a} , then $\mathbf{T} = \mathbf{I}$.

Example 2.14.1

Write the tensor \mathbf{T} , defined by the equation $\mathbf{T}\mathbf{a} = \alpha\mathbf{a}$, where α is a constant and \mathbf{a} is arbitrary, in terms of the identity tensor, and find its components.

Solution

Using Eq. (2.14.1), we can write $\alpha\mathbf{a}$ as $\alpha\mathbf{I}\mathbf{a}$, so that

$$\mathbf{T}\mathbf{a} = \alpha\mathbf{a} = \alpha\mathbf{I}\mathbf{a}.$$

Since \mathbf{a} is arbitrary, therefore,

$$\mathbf{T} = \alpha\mathbf{I}.$$

The components of this tensor are clearly $T_{ij} = \alpha\delta_{ij}$.

Given a tensor \mathbf{T} , if a tensor \mathbf{S} exists such that

$$\mathbf{S}\mathbf{T} = \mathbf{I}, \quad (2.14.5)$$

then we call \mathbf{S} the inverse of \mathbf{T} and write

$$\mathbf{S} = \mathbf{T}^{-1}. \quad (2.14.6)$$

To find the components of the inverse of a tensor \mathbf{T} is to find the inverse of the matrix of \mathbf{T} . From the study of matrices, we know that the inverse exists if and only if $\det \mathbf{T} \neq 0$ (that is, \mathbf{T} is nonsingular) and in this case,

$$[\mathbf{T}]^{-1}[\mathbf{T}] = [\mathbf{T}][\mathbf{T}]^{-1} = [\mathbf{I}]. \quad (2.14.7)$$

Thus, the inverse of a tensor satisfies the following relation:

$$\mathbf{T}^{-1}\mathbf{T} = \mathbf{T}\mathbf{T}^{-1} = \mathbf{I}. \quad (2.14.8)$$

It can be shown (see Prob. 2.35) that for the tensor inverse, the following relations are satisfied:

$$(\mathbf{T}^T)^{-1} = (\mathbf{T}^{-1})^T, \quad (2.14.9)$$

and

$$(\mathbf{T}\mathbf{S})^{-1} = \mathbf{S}^{-1}\mathbf{T}^{-1}. \quad (2.14.10)$$

We note that if the inverse exists, we have the reciprocal relations that

$$\mathbf{T}\mathbf{a} = \mathbf{b} \quad \text{and} \quad \mathbf{a} = \mathbf{T}^{-1}\mathbf{b}. \quad (2.14.11)$$

This indicates that when a tensor is invertible, there is a one-to-one mapping of vectors \mathbf{a} and \mathbf{b} . On the other hand, if a tensor \mathbf{T} does not have an inverse, then, for a given \mathbf{b} , there are in general more than one \mathbf{a} that transform into \mathbf{b} . This fact is illustrated in the following example.

Example 2.14.2

Consider the tensor $\mathbf{T} = \mathbf{cd}$ (the dyadic product of \mathbf{c} and \mathbf{d}).

- (a) Obtain the determinant of \mathbf{T} .
 (b) Show that if $\mathbf{Ta} = \mathbf{b}$, then $\mathbf{T}(\mathbf{a} + \mathbf{h}) = \mathbf{b}$, where \mathbf{h} is any vector perpendicular to the vector \mathbf{d} .

Solution

$$(a) \quad [\mathbf{T}] = \begin{bmatrix} c_1 \\ c_2 \\ c_3 \end{bmatrix} [d_1 \quad d_2 \quad d_3] = \begin{bmatrix} c_1 d_1 & c_1 d_2 & c_1 d_3 \\ c_2 d_1 & c_2 d_2 & c_2 d_3 \\ c_3 d_1 & c_3 d_2 & c_3 d_3 \end{bmatrix} \quad \text{and} \quad \det [\mathbf{T}] = c_1 c_2 c_3 d_1 d_2 d_3 \begin{vmatrix} 1 & 1 & 1 \\ 1 & 1 & 1 \\ 1 & 1 & 1 \end{vmatrix} = 0.$$

That is, \mathbf{T} is a singular tensor, for which an inverse does not exist.

- (b) $\mathbf{T}(\mathbf{a} + \mathbf{h}) = (\mathbf{cd})(\mathbf{a} + \mathbf{h}) = \mathbf{c}(\mathbf{d} \cdot \mathbf{a}) + \mathbf{c}(\mathbf{d} \cdot \mathbf{h})$. Now $\mathbf{d} \cdot \mathbf{h} = 0$ (\mathbf{h} is perpendicular to \mathbf{d}); therefore,

$$\mathbf{T}(\mathbf{a} + \mathbf{h}) = \mathbf{c}(\mathbf{d} \cdot \mathbf{a}) = (\mathbf{cd})\mathbf{a} = \mathbf{Ta} = \mathbf{b}.$$

That is, all vectors $\mathbf{a} + \mathbf{h}$ transform into the vector \mathbf{b} , and it is not a one-to-one transformation.

2.15 ORTHOGONAL TENSORS

An *orthogonal tensor* is a linear transformation under which the transformed vectors preserve their lengths and angles. Let \mathbf{Q} denote an orthogonal tensor; then by definition, $|\mathbf{Qa}| = |\mathbf{a}|$, $|\mathbf{Qb}| = |\mathbf{b}|$, and $\cos(\mathbf{a}, \mathbf{b}) = \cos(\mathbf{Qa}, \mathbf{Qb})$. Therefore,

$$\mathbf{Qa} \cdot \mathbf{Qb} = \mathbf{a} \cdot \mathbf{b} \quad (2.15.1)$$

for any vectors \mathbf{a} and \mathbf{b} .

Since by the definition of transpose, Eq. (2.11.1), $(\mathbf{Qa}) \cdot (\mathbf{Qb}) = \mathbf{b} \cdot \mathbf{Q}^T(\mathbf{Qa})$, thus

$$\mathbf{b} \cdot \mathbf{a} = \mathbf{b} \cdot (\mathbf{Q}^T \mathbf{Q})\mathbf{a} \quad \text{or} \quad \mathbf{b} \cdot \mathbf{Ia} = \mathbf{b} \cdot \mathbf{Q}^T \mathbf{Qa}.$$

Since \mathbf{a} and \mathbf{b} are arbitrary, it follows that

$$\mathbf{Q}^T \mathbf{Q} = \mathbf{I}. \quad (2.15.2)$$

This means that for an orthogonal tensor, the inverse is simply the transpose,

$$\mathbf{Q}^{-1} = \mathbf{Q}^T. \quad (2.15.3)$$

Thus [see Eq. (2.14.8)],

$$\mathbf{Q}^T \mathbf{Q} = \mathbf{Q} \mathbf{Q}^T = \mathbf{I}. \quad (2.15.4)$$

In matrix notation, Eq. (2.15.4) takes the form:

$$[\mathbf{Q}]^T[\mathbf{Q}] = [\mathbf{Q}][\mathbf{Q}]^T = [\mathbf{I}], \quad (2.15.5)$$

and in subscript notation, we have

$$Q_{mi}Q_{mj} = Q_{im}Q_{jm} = \delta_{ij}. \quad (2.15.6)$$

Example 2.15.1

The tensor given in Example 2.7.2, being a reflection, is obviously an orthogonal tensor. Verify that $[\mathbf{T}][\mathbf{T}]^T = [\mathbf{I}]$ for the $[\mathbf{T}]$ in that example. Also, find the determinant of $[\mathbf{T}]$.

Solution

Evaluating the matrix product:

$$[\mathbf{T}][\mathbf{T}]^T = \begin{bmatrix} -1 & 0 & 0 \\ 0 & 1 & 0 \\ 0 & 0 & 1 \end{bmatrix} \begin{bmatrix} -1 & 0 & 0 \\ 0 & 1 & 0 \\ 0 & 0 & 1 \end{bmatrix} = \begin{bmatrix} 1 & 0 & 0 \\ 0 & 1 & 0 \\ 0 & 0 & 1 \end{bmatrix}.$$

The determinant of \mathbf{T} is

$$|\mathbf{T}| = \begin{vmatrix} -1 & 0 & 0 \\ 0 & 1 & 0 \\ 0 & 0 & 1 \end{vmatrix} = -1.$$

Example 2.15.2

The tensor given in Example 2.7.3, being a rigid body rotation, is obviously an orthogonal tensor. Verify that $[\mathbf{R}][\mathbf{R}]^T = [\mathbf{I}]$ for the $[\mathbf{R}]$ in that example. Also find the determinant of $[\mathbf{R}]$.

Solution

$$[\mathbf{R}][\mathbf{R}]^T = \begin{bmatrix} \cos \theta & -\sin \theta & 0 \\ \sin \theta & \cos \theta & 0 \\ 0 & 0 & 1 \end{bmatrix} \begin{bmatrix} \cos \theta & \sin \theta & 0 \\ -\sin \theta & \cos \theta & 0 \\ 0 & 0 & 1 \end{bmatrix} = \begin{bmatrix} 1 & 0 & 0 \\ 0 & 1 & 0 \\ 0 & 0 & 1 \end{bmatrix},$$

$$\det[\mathbf{R}] = |\mathbf{R}| = \begin{vmatrix} \cos \theta & -\sin \theta & 0 \\ \sin \theta & \cos \theta & 0 \\ 0 & 0 & 1 \end{vmatrix} = 1.$$

The determinant of the matrix of any orthogonal tensor \mathbf{Q} is easily shown to be equal to either $+1$ or -1 . In fact, since

$$[\mathbf{Q}][\mathbf{Q}]^T = [\mathbf{I}],$$

therefore,

$$|[\mathbf{Q}][\mathbf{Q}]^T| = |\mathbf{Q}||\mathbf{Q}^T| = |\mathbf{I}|.$$

Now $|\mathbf{Q}| = |\mathbf{Q}^T|$ and $|\mathbf{I}| = 1$, therefore, $|\mathbf{Q}|^2 = 1$, thus

$$|\mathbf{Q}| = \pm 1. \quad (2.15.7)$$

From the previous examples, we can see that for a rotation tensor the determinant is $+1$, whereas for a reflection tensor, it is -1 .

2.16 TRANSFORMATION MATRIX BETWEEN TWO RECTANGULAR CARTESIAN COORDINATE SYSTEMS

Suppose that $\{\mathbf{e}_1, \mathbf{e}_2, \mathbf{e}_3\}$ and $\{\mathbf{e}'_1, \mathbf{e}'_2, \mathbf{e}'_3\}$ are unit vectors corresponding to two rectangular Cartesian coordinate systems (see Figure 2.16-1). It is clear that $\{\mathbf{e}_1, \mathbf{e}_2, \mathbf{e}_3\}$ can be made to coincide with $\{\mathbf{e}'_1, \mathbf{e}'_2, \mathbf{e}'_3\}$ through either a rigid body rotation (if both bases are same-handed) or a rotation followed by a reflection (if different-handed). That is, $\{\mathbf{e}_i\}$ and $\{\mathbf{e}'_i\}$ are related by an orthogonal tensor \mathbf{Q} through the equations below.

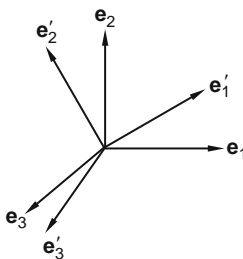

FIGURE 2.16-1

$$\mathbf{e}'_i = \mathbf{Q}\mathbf{e}_i = Q_{mi}\mathbf{e}_m, \quad (2.16.1)$$

that is,

$$\begin{aligned} \mathbf{e}'_1 &= Q_{11}\mathbf{e}_1 + Q_{21}\mathbf{e}_2 + Q_{31}\mathbf{e}_3, \\ \mathbf{e}'_2 &= Q_{12}\mathbf{e}_1 + Q_{22}\mathbf{e}_2 + Q_{32}\mathbf{e}_3, \\ \mathbf{e}'_3 &= Q_{13}\mathbf{e}_1 + Q_{23}\mathbf{e}_2 + Q_{33}\mathbf{e}_3, \end{aligned} \quad (2.16.2)$$

where

$$Q_{im}Q_{jm} = Q_{mi}Q_{mj} = \delta_{ij}, \quad (2.16.3)$$

or

$$\mathbf{Q}\mathbf{Q}^T = \mathbf{Q}^T\mathbf{Q} = \mathbf{I}. \quad (2.16.4)$$

We note that

$$\begin{aligned} Q_{11} &= \mathbf{e}_1 \cdot \mathbf{Q}\mathbf{e}_1 = \mathbf{e}_1 \cdot \mathbf{e}'_1 = \text{cosine of the angle between } \mathbf{e}_1 \text{ and } \mathbf{e}'_1, \\ Q_{12} &= \mathbf{e}_1 \cdot \mathbf{Q}\mathbf{e}_2 = \mathbf{e}_1 \cdot \mathbf{e}'_2 = \text{cosine of the angle between } \mathbf{e}_1 \text{ and } \mathbf{e}'_2, \text{ etc.} \end{aligned}$$

That is, in general, $Q_{ij} = \text{cosine of the angle between } \mathbf{e}_i \text{ and } \mathbf{e}'_j$, which may be written:

$$Q_{ij} = \cos(\mathbf{e}_i, \mathbf{e}'_j). \quad (2.16.5)$$

The matrix of these direction cosines, i.e., the matrix

$$[\mathbf{Q}] = \begin{bmatrix} Q_{11} & Q_{12} & Q_{13} \\ Q_{21} & Q_{22} & Q_{23} \\ Q_{31} & Q_{32} & Q_{33} \end{bmatrix}, \quad (2.16.6)$$

is called the *transformation matrix* between $\{\mathbf{e}_1, \mathbf{e}_2, \mathbf{e}_3\}$ and $\{\mathbf{e}'_1, \mathbf{e}'_2, \mathbf{e}'_3\}$. Using this matrix, we shall obtain in the following sections the relationship between the two sets of components, with respect to these two sets of base vectors, of a vector and a tensor.

Example 2.16.1

Let $\{\mathbf{e}'_1, \mathbf{e}'_2, \mathbf{e}'_3\}$ be obtained by rotating the basis $\{\mathbf{e}_1, \mathbf{e}_2, \mathbf{e}_3\}$ about the \mathbf{e}_3 axis through 30° , as shown in Figure 2.16-2. In this figure, \mathbf{e}_3 and \mathbf{e}'_3 coincide.

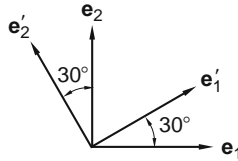

FIGURE 2.16-2

Solution

We can obtain the transformation matrix in two ways:

- Using Eq. (2.16.5), we have

$$\begin{aligned} Q_{11} &= \cos(\mathbf{e}_1, \mathbf{e}'_1) = \cos 30^\circ = \sqrt{3}/2, & Q_{12} &= \cos(\mathbf{e}_1, \mathbf{e}'_2) = \cos 120^\circ = -1/2, & Q_{13} &= \cos(\mathbf{e}_1, \mathbf{e}'_3) = \cos 90^\circ = 0, \\ Q_{21} &= \cos(\mathbf{e}_2, \mathbf{e}'_1) = \cos 60^\circ = 1/2, & Q_{22} &= \cos(\mathbf{e}_2, \mathbf{e}'_2) = \cos 30^\circ = \sqrt{3}/2, & Q_{23} &= \cos(\mathbf{e}_2, \mathbf{e}'_3) = \cos 90^\circ = 0, \\ Q_{31} &= \cos(\mathbf{e}_3, \mathbf{e}'_1) = \cos 90^\circ = 0, & Q_{32} &= \cos(\mathbf{e}_3, \mathbf{e}'_2) = \cos 90^\circ = 0, & Q_{33} &= \cos(\mathbf{e}_3, \mathbf{e}'_3) = \cos 0^\circ = 1. \end{aligned}$$

- It is easier to simply look at Figure 2.16-2 and decompose each of the \mathbf{e}'_i into its components in the $\{\mathbf{e}_1, \mathbf{e}_2, \mathbf{e}_3\}$ directions, i.e.,

$$\begin{aligned} \mathbf{e}'_1 &= \cos 30^\circ \mathbf{e}_1 + \sin 30^\circ \mathbf{e}_2 = \frac{\sqrt{3}}{2} \mathbf{e}_1 + \frac{1}{2} \mathbf{e}_2, \\ \mathbf{e}'_2 &= -\sin 30^\circ \mathbf{e}_1 + \cos 30^\circ \mathbf{e}_2 = -\frac{1}{2} \mathbf{e}_1 + \frac{\sqrt{3}}{2} \mathbf{e}_2, \\ \mathbf{e}'_3 &= \mathbf{e}_3. \end{aligned}$$

Thus, by Eq. (2.16.2), we have

$$[\mathbf{Q}] = \begin{bmatrix} \sqrt{3}/2 & -1/2 & 0 \\ 1/2 & \sqrt{3}/2 & 0 \\ 0 & 0 & 1 \end{bmatrix}.$$

2.17 TRANSFORMATION LAW FOR CARTESIAN COMPONENTS OF A VECTOR

Consider any vector \mathbf{a} . The Cartesian components of the vector \mathbf{a} with respect to $\{\mathbf{e}_1, \mathbf{e}_2, \mathbf{e}_3\}$ are:

$$a_i = \mathbf{a} \cdot \mathbf{e}_i, \quad (2.17.1)$$

and its components with respect to $\{\mathbf{e}'_1, \mathbf{e}'_2, \mathbf{e}'_3\}$ are:

$$a'_i = \mathbf{a} \cdot \mathbf{e}'_i. \quad (2.17.2)$$

Now $\mathbf{e}'_i = Q_{mi}\mathbf{e}_m$ [see Eq. (2.16.1)]; therefore,

$$a'_i = \mathbf{a} \cdot Q_{mi}\mathbf{e}_m = Q_{mi}(\mathbf{a} \cdot \mathbf{e}_m), \quad (2.17.3)$$

that is,

$$a'_i = Q_{mi}a_m. \quad (2.17.4)$$

In matrix notation, Eq. (2.17.4) is

$$\begin{bmatrix} a'_1 \\ a'_2 \\ a'_3 \end{bmatrix} = \begin{bmatrix} Q_{11} & Q_{21} & Q_{31} \\ Q_{12} & Q_{22} & Q_{32} \\ Q_{13} & Q_{23} & Q_{33} \end{bmatrix} \begin{bmatrix} a_1 \\ a_2 \\ a_3 \end{bmatrix}, \quad (2.17.5)$$

or

$$[\mathbf{a}]' = [\mathbf{Q}]^T[\mathbf{a}]. \quad (2.17.6)$$

Equation (2.17.4), or Eq. (2.17.5), or Eq. (2.17.6) is the transformation law relating components of the *same* vector with respect to different rectangular Cartesian unit bases. It is very important to note that in Eq. (2.17.6), $[\mathbf{a}]'$ denotes the matrix of the vector \mathbf{a} with respect to the primed basis $\{\mathbf{e}'_i\}$, and $[\mathbf{a}]$ denotes the same vector with respect to the unprimed basis $\{\mathbf{e}_i\}$. Eq. (2.17.6) is not the same as $\mathbf{a}' = \mathbf{Q}^T\mathbf{a}$. The distinction is that $[\mathbf{a}]'$ and $[\mathbf{a}]$ are matrices of the same vector, whereas \mathbf{a} and \mathbf{a}' are two different vectors— \mathbf{a}' being the transformed vector of \mathbf{a} (through the transformation $\mathbf{a}' = \mathbf{Q}^T\mathbf{a}$).

If we premultiply Eq. (2.17.6) with $[\mathbf{Q}]$, we get

$$[\mathbf{a}] = [\mathbf{Q}][\mathbf{a}]'. \quad (2.17.7)$$

The indicial notation for this equation is:

$$a_i = Q_{im}a'_m. \quad (2.17.8)$$

Example 2.17.1

Given that the components of a vector \mathbf{a} with respect to $\{\mathbf{e}_i\}$ are given to be $[2,0,0]$. That is, $\mathbf{a} = 2\mathbf{e}_1$, find its components with respect to $\{\mathbf{e}'_i\}$, where the $\{\mathbf{e}'_i\}$ axes are obtained by a 90° counter-clockwise rotation of the $\{\mathbf{e}_i\}$ axis about its \mathbf{e}_3 axis.

Solution

The answer to the question is obvious from Figure 2.17-1, that is,

$$\mathbf{a} = 2\mathbf{e}_1 = -2\mathbf{e}'_2.$$

To show that we can get the same answer from Eq. (2.17.6), we first obtain the transformation matrix of \mathbf{Q} . Since $\mathbf{e}'_1 = \mathbf{e}_2$, $\mathbf{e}'_2 = -\mathbf{e}_1$ and $\mathbf{e}'_3 = \mathbf{e}_3$, we have

$$[\mathbf{Q}] = \begin{bmatrix} 0 & -1 & 0 \\ 1 & 0 & 0 \\ 0 & 0 & 1 \end{bmatrix}.$$

Thus,

$$[\mathbf{a}]' = [\mathbf{Q}]^T [\mathbf{a}] = \begin{bmatrix} 0 & 1 & 0 \\ -1 & 0 & 0 \\ 0 & 0 & 1 \end{bmatrix} \begin{bmatrix} 2 \\ 0 \\ 0 \end{bmatrix} = \begin{bmatrix} 0 \\ -2 \\ 0 \end{bmatrix},$$

that is,

$$\mathbf{a} = -2\mathbf{e}'_2.$$

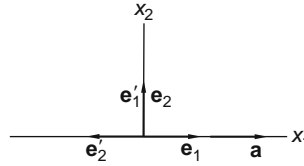

FIGURE 2.17-1

2.18 TRANSFORMATION LAW FOR CARTESIAN COMPONENTS OF A TENSOR

Consider any tensor \mathbf{T} . The components of \mathbf{T} with respect to the basis $\{\mathbf{e}_1, \mathbf{e}_2, \mathbf{e}_3\}$ are:

$$T_{ij} = \mathbf{e}_i \cdot \mathbf{T} \mathbf{e}_j. \quad (2.18.1)$$

Its components with respect to $\{\mathbf{e}'_1, \mathbf{e}'_2, \mathbf{e}'_3\}$ are:

$$T'_{ij} = \mathbf{e}'_i \cdot \mathbf{T} \mathbf{e}'_j. \quad (2.18.2)$$

With $\mathbf{e}'_i = Q_{mi} \mathbf{e}_m$, we have

$$T'_{ij} = Q_{mi} \mathbf{e}_m \cdot \mathbf{T} Q_{nj} \mathbf{e}_n = Q_{mi} Q_{nj} \mathbf{e}_m \cdot \mathbf{T} \mathbf{e}_n,$$

that is,

$$T'_{ij} = Q_{mi} Q_{nj} T_{mn}. \quad (2.18.3)$$

In matrix notation, the preceding equation reads:

$$\begin{bmatrix} T'_{11} & T'_{12} & T'_{13} \\ T'_{21} & T'_{22} & T'_{23} \\ T'_{31} & T'_{32} & T'_{33} \end{bmatrix} = \begin{bmatrix} Q_{11} & Q_{21} & Q_{31} \\ Q_{12} & Q_{22} & Q_{32} \\ Q_{13} & Q_{23} & Q_{33} \end{bmatrix} \begin{bmatrix} T_{11} & T_{12} & T_{13} \\ T_{21} & T_{22} & T_{23} \\ T_{31} & T_{32} & T_{33} \end{bmatrix} \begin{bmatrix} Q_{11} & Q_{12} & Q_{13} \\ Q_{21} & Q_{22} & Q_{23} \\ Q_{31} & Q_{32} & Q_{33} \end{bmatrix}, \quad (2.18.4)$$

or

$$[\mathbf{T}]' = [\mathbf{Q}]^T [\mathbf{T}] [\mathbf{Q}]. \quad (2.18.5)$$

We can also express the unprimed components in terms of the primed components. Indeed, if we premultiply the preceding equation with $[\mathbf{Q}]$ and post-multiply it with $[\mathbf{Q}]^T$, we obtain, since

$$[\mathbf{Q}][\mathbf{Q}]^T = [\mathbf{Q}]^T[\mathbf{Q}] = [\mathbf{I}], \quad (2.18.6)$$

$$[\mathbf{T}] = [\mathbf{Q}][\mathbf{T}'][\mathbf{Q}]^T. \quad (2.18.7)$$

In indicial notation, Eq. (2.18.7) reads

$$T_{ij} = Q_{im}Q_{jn}T'_{mn}. \quad (2.18.8)$$

Equations (2.18.5) [or Eq. (2.18.3)] and Eq. (2.18.7) [or Eq. (2.18.8)] are the transformation laws relating components of the *same* tensor with respect to different Cartesian unit bases. Again, it is important to note that in Eqs. (2.18.5) and (2.18.7), $[\mathbf{T}]$ and $[\mathbf{T}]'$ are different matrices of the *same* tensor \mathbf{T} . We note that the equation $[\mathbf{T}]' = [\mathbf{Q}]^T[\mathbf{T}][\mathbf{Q}]$ differs from $\mathbf{T}' = \mathbf{Q}^T\mathbf{T}\mathbf{Q}$ in that the former relates the components of the same tensor \mathbf{T} whereas the latter relates the two different tensors \mathbf{T} and \mathbf{T}' .

Example 2.18.1

Given that with respect to the basis $\{\mathbf{e}_1, \mathbf{e}_2, \mathbf{e}_3\}$, the matrix of a tensor \mathbf{T} is given by

$$[\mathbf{T}] = \begin{bmatrix} 0 & 1 & 0 \\ 1 & 2 & 0 \\ 0 & 0 & 1 \end{bmatrix}.$$

Find $[\mathbf{T}]'$, that is, find the matrix of \mathbf{T} with respect to the \mathbf{e}'_i basis, where $\{\mathbf{e}'_1, \mathbf{e}'_2, \mathbf{e}'_3\}$ is obtained by rotating $\{\mathbf{e}_1, \mathbf{e}_2, \mathbf{e}_3\}$ about its \mathbf{e}_3 -axis through 90° (see Figure 2.17-1).

Solution

Since $\mathbf{e}'_1 = \mathbf{e}_2$, $\mathbf{e}'_2 = -\mathbf{e}_1$ and $\mathbf{e}'_3 = \mathbf{e}_3$, by Eq. (2.7.1) we have

$$[\mathbf{Q}] = \begin{bmatrix} 0 & -1 & 0 \\ 1 & 0 & 0 \\ 0 & 0 & 1 \end{bmatrix}.$$

Thus, Eq. (2.18.5) gives

$$[\mathbf{T}]' = \begin{bmatrix} 0 & 1 & 0 \\ -1 & 0 & 0 \\ 0 & 0 & 1 \end{bmatrix} \begin{bmatrix} 0 & 1 & 0 \\ 1 & 2 & 0 \\ 0 & 0 & 1 \end{bmatrix} \begin{bmatrix} 0 & -1 & 0 \\ 1 & 0 & 0 \\ 0 & 0 & 1 \end{bmatrix} = \begin{bmatrix} 2 & -1 & 0 \\ -1 & 0 & 0 \\ 0 & 0 & 1 \end{bmatrix},$$

that is,

$$T'_{11} = 2, \quad T'_{12} = -1, \quad T'_{13} = 0, \quad T'_{22} = 0, \quad T'_{23} = 0, \quad T'_{33} = 1.$$

Example 2.18.2

Given a tensor \mathbf{T} and its components T_{ij} and T'_{ij} with respect to two sets of bases $\{\mathbf{e}_j\}$ and $\{\mathbf{e}'_j\}$. Show that T_{ij} is invariant with respect to these bases, i.e., $T_{ij} = T'_{ij}$.

Solution

The primed components are related to the unprimed components by Eq. (2.18.3):

$$T'_{ij} = Q_{mi}Q_{nj}T_{mn},$$

thus,

$$T'_{ij} = Q_{mi}Q_{nj}T_{mn}.$$

But $Q_{mi}Q_{ni} = \delta_{mn}$ [Eq. (2.15.6)], therefore,

$$T'_{ij} = \delta_{mn}T_{mn} = T_{mm} = T_{ii},$$

that is,

$$T_{11} + T_{22} + T_{33} = T'_{11} + T'_{22} + T'_{33}.$$

We see from Example 2.18.1 that we can calculate all nine components of a tensor \mathbf{T} with respect to $\{\mathbf{e}'_i\}$ from the matrix $[T]_{\{\mathbf{e}_i\}}$ by using Eq. (2.18.5). However, there are often times when we need only a few components. Then it is more convenient to use Eq. (2.18.1). In matrix form, this equation is written:

$$T'_{ij} = [\mathbf{e}'_i]^T [\mathbf{T}] [\mathbf{e}'_j], \quad (2.18.9)$$

where $[\mathbf{e}'_i]^T$ denote the row matrix whose elements are the components of \mathbf{e}'_i with respect to the basis $\{\mathbf{e}_i\}$.

Example 2.18.3

Obtain T'_{12} for the tensor \mathbf{T} and the bases $\{\mathbf{e}_i\}$ and $\{\mathbf{e}'_i\}$ given in Example 2.18.1 by using Eq. (2.18.1).

Solution

Since $\mathbf{e}'_1 = \mathbf{e}_2$ and $\mathbf{e}'_2 = -\mathbf{e}_1$, therefore,

$$T'_{12} = \mathbf{e}'_1 \cdot \mathbf{T} \mathbf{e}'_2 = \mathbf{e}_2 \cdot \mathbf{T} (-\mathbf{e}_1) = -T_{21} = -1.$$

Alternatively, using Eq. (2.18.9), we have

$$T'_{12} = [\mathbf{e}'_1]^T [\mathbf{T}] [\mathbf{e}'_2] = [0 \ 1 \ 0] \begin{bmatrix} 0 & 1 & 0 \\ 1 & 2 & 0 \\ 0 & 0 & 1 \end{bmatrix} \begin{bmatrix} -1 \\ 0 \\ 0 \end{bmatrix} = [0 \ 1 \ 0] \begin{bmatrix} 0 \\ -1 \\ 0 \end{bmatrix} = -1.$$

2.19 DEFINING TENSOR BY TRANSFORMATION LAWS

Equation (2.17.4) or (2.18.3) states that when the components of a vector or a tensor with respect to $\{\mathbf{e}_1, \mathbf{e}_2, \mathbf{e}_3\}$ are known, then its components with respect to any $\{\mathbf{e}'_1, \mathbf{e}'_2, \mathbf{e}'_3\}$ are uniquely determined from them. In other words, the components a_i or T_{ij} with respect to one set of $\{\mathbf{e}_1, \mathbf{e}_2, \mathbf{e}_3\}$ completely characterize a vector or a tensor. Thus, it is perfectly meaningful to use a statement such as “*consider a tensor T_{ij} ,*” meaning consider the tensor \mathbf{T} whose components with respect to some set of $\{\mathbf{e}_1, \mathbf{e}_2, \mathbf{e}_3\}$ are T_{ij} . In fact, an alternative way of defining a tensor is through the use of transformation laws relating components of a tensor with respect to different bases. Confining ourselves to only rectangular Cartesian coordinate systems and using unit vectors along positive coordinate directions as base vectors, we now define Cartesian components of tensors of different orders in terms of their transformation laws in the following, where the primed quantities are

referred to basis $\{\mathbf{e}'_1, \mathbf{e}'_2, \mathbf{e}'_3\}$ and unprimed quantities to basis $\{\mathbf{e}_1, \mathbf{e}_2, \mathbf{e}_3\}$, where the \mathbf{e}'_i and \mathbf{e}_i are related by $\mathbf{e}'_i = \mathbf{Q}\mathbf{e}_i$, \mathbf{Q} being an orthogonal transformation:

$$\begin{array}{ll}
 \alpha' = \alpha & \text{zeroth-order tensor (or scalar),} \\
 a'_i = Q_{mi}a_m & \text{first-order tensor (or vector),} \\
 T'_{ij} = Q_{mi}Q_{nj}T_{mn} & \text{second-order tensor (or tensor),} \\
 S'_{ijk} = Q_{mi}Q_{nj}Q_{rk}S_{mnr} & \text{third-order tensor,} \\
 C'_{ijkl} = Q_{mi}Q_{nj}Q_{rk}Q_{sl}C_{mnrsl} & \text{fourth-order tensor,} \\
 \dots & \dots
 \end{array} \tag{2.19.1}$$

Using the preceding transformation laws, we can easily establish the following three rules for tensor components: (1) the addition rule, (2) the multiplication rule, and (3) the quotient rule.

1. *The addition rule.* If T_{ij} and S_{ij} are components of any two second-order tensors, then $T_{ij} + S_{ij}$ are components of a second-order tensor. Similarly, if T_{ijk} and S_{ijk} are components of any two third-order tensors, then $T_{ijk} + S_{ijk}$ are components of a third-order tensor.

To prove this rule, we note that since $T'_{ijk} = Q_{mi}Q_{nj}Q_{rk}T_{mnr}$ and $S'_{ijk} = Q_{mi}Q_{nj}Q_{rk}S_{mnr}$, thus,

$$T'_{ijk} + S'_{ijk} = Q_{mi}Q_{nj}Q_{rk}T_{mnr} + Q_{mi}Q_{nj}Q_{rk}S_{mnr} = Q_{mi}Q_{nj}Q_{rk}(T_{mnr} + S_{mnr}).$$

Letting

$$W'_{ijk} = T'_{ijk} + S'_{ijk} \quad \text{and} \quad W_{mnr} = T_{mnr} + S_{mnr},$$

we have

$$W'_{ijk} = Q_{mi}Q_{nj}Q_{rk}W_{mnr},$$

that is, W_{ijk} are components of a third-order tensor.

2. *The multiplication rule.* Let a_i be components of any vector and T_{ij} be components of any tensor. We can form many kinds of products from these components. Examples are (a) $a_i a_j$, (b) $a_i a_j a_k$, (c) $T_{ij} T_{kl}$, (d) $T_{ij} T_{jk}$, etc. It can be proved that these products are components of a tensor whose order is equal to the number of free indices. For example, $a_i a_j$ are components of a second-order tensor, $a_i a_j a_k$ are components of a third-order tensor, $T_{ij} T_{kl}$ are components of a fourth-order tensor, and $T_{ij} T_{jk}$ are components of a second-order tensor.

To prove that $a_i a_j$ are components of a second-order tensor, we let $S_{ij} = a_i a_j$ and $S'_{ij} = a'_i a'_j$, then, since a_i are components of the vector \mathbf{a} , $a'_i = Q_{mi} a_m$ and $a'_j = Q_{nj} a_n$, so that

$$S'_{ij} = Q_{mi} a_m Q_{nj} a_n = Q_{mi} Q_{nj} a_m a_n = Q_{mi} Q_{nj} S_{mn},$$

thus,

$$S'_{ij} = Q_{mi} Q_{nj} S_{mn},$$

which is the transformation law for a second-order tensor.

To prove that $T_{ij} T_{kl}$ are components of a fourth-order tensor, let $M_{ijkl} = T_{ij} T_{kl}$; then we have

$$M'_{ijkl} = T'_{ij} T'_{kl} = Q_{mi} Q_{nj} T_{mn} Q_{rk} Q_{sl} T_{rs} = Q_{mi} Q_{nj} Q_{rk} Q_{sl} T_{mn} T_{rs},$$

that is,

$$M'_{ijkl} = Q_{mi} Q_{nj} Q_{rk} Q_{sl} M_{mnrsl},$$

which is the transformation law for a fourth-order tensor. It is quite clear from the proofs given above that the order of the tensor whose components are obtained from the multiplication of components of tensors

is determined by the number of free indices; no free index corresponds to a scalar, one free index corresponds to a vector, two free indices correspond to a second-order tensor, and so on.

3. *Quotient rule.* If a_i are components of an arbitrary vector, T_{ij} are components of an arbitrary tensor, and $a_i = T_{ij}b_j$ for all coordinates, then b_i are components of a vector.

To prove this, we note that since a_i are components of a vector and T_{ij} are components of a second-order tensor, therefore,

$$a_i = Q_{im}a'_m, \quad (\text{i})$$

and

$$T_{ij} = Q_{im}Q_{jn}T'_{mn}. \quad (\text{ii})$$

Now, substituting Eq. (i) and Eq. (ii) into the equation $a_i = T_{ij}b_j$, we have

$$Q_{im}a'_m = Q_{im}Q_{jn}T'_{mn}b_j. \quad (\text{iii})$$

But the equation $a_i = T_{ij}b_j$ is true for all coordinates, thus we also have

$$a'_i = T'_{ij}b'_j \quad \text{and} \quad a'_m = T'_{mn}b'_n, \quad (\text{iv})$$

and thus Eq. (iii) becomes

$$Q_{im}T'_{mn}b'_n = Q_{im}Q_{jn}T'_{mn}b_j. \quad (\text{v})$$

Multiplying the preceding equation with Q_{ik} and noting that $Q_{ik}Q_{im} = \delta_{km}$, we get

$$\delta_{km}T'_{mn}b'_n = \delta_{km}Q_{jn}T'_{mn}b_j \quad \text{or} \quad T'_{kn}b'_n = Q_{jn}T'_{kn}b_j,$$

thus,

$$T'_{kn}(b'_n - Q_{jn}b_j) = 0. \quad (\text{vi})$$

Since this equation is to be true for any tensor \mathbf{T} , therefore $b'_n - Q_{jn}b_j$ must be identically zero. Thus,

$$b'_n = Q_{jn}b_j. \quad (\text{vii})$$

This is the transformation law for the components of a vector. Thus, b_i are components of a vector.

Another example that will be important later when we discuss the relationship between stress and strain for an elastic body is the following: If T_{ij} and E_{ij} are components of arbitrary second-order tensors \mathbf{T} and \mathbf{E} , and

$$T_{ij} = C_{ijkl}E_{kl}, \quad (\text{viii})$$

for all coordinates, then C_{ijkl} are components of a fourth-order tensor. The proof for this example follows exactly the same steps as in the previous example.

2.20 SYMMETRIC AND ANTISYMMETRIC TENSORS

A tensor is said to be symmetric if $\mathbf{T} = \mathbf{T}^T$. Thus, the components of a symmetric tensor have the property

$$T_{ij} = T_{ji}, \quad (2.20.1)$$

that is,

$$T_{12} = T_{21}, \quad T_{13} = T_{31}, \quad T_{23} = T_{32}. \quad (2.20.2)$$

A tensor is said to be antisymmetric if $\mathbf{T} = -\mathbf{T}^T$. Thus the components of an antisymmetric tensor have the property

$$T_{ij} = -T_{ji}, \quad (2.20.3)$$

that is,

$$T_{11} = T_{22} = T_{33} = 0, \quad T_{12} = -T_{21}, \quad T_{13} = -T_{31}, \quad T_{23} = -T_{32}. \quad (2.20.4)$$

Any tensor \mathbf{T} can always be decomposed into the sum of a symmetric tensor and an antisymmetric tensor. In fact,

$$\mathbf{T} = \mathbf{T}^S + \mathbf{T}^A, \quad (2.20.5)$$

where

$$\mathbf{T}^S = \frac{\mathbf{T} + \mathbf{T}^T}{2} \text{ is symmetric and } \mathbf{T}^A = \frac{\mathbf{T} - \mathbf{T}^T}{2} \text{ is anti-symmetric.} \quad (2.20.6)$$

It is not difficult to prove that the decomposition is unique (see Prob. 2.47).

2.21 THE DUAL VECTOR OF AN ANTISYMMETRIC TENSOR

The diagonal elements of an antisymmetric tensor are always zero, and, of the six nondiagonal elements, only three are independent, because $T_{12} = -T_{21}$, $T_{23} = -T_{32}$ and $T_{31} = -T_{13}$. Thus an antisymmetric tensor has really only three components, just like a vector. Indeed, it does behave like a vector. More specifically, for every antisymmetric tensor \mathbf{T} there is a corresponding vector \mathbf{t}^A such that for every vector \mathbf{a} , the transformed vector of \mathbf{a} under \mathbf{T} , i.e., $\mathbf{T}\mathbf{a}$, can be obtained from the cross-product of \mathbf{t}^A with the vector \mathbf{a} . That is,

$$\mathbf{T}\mathbf{a} = \mathbf{t}^A \times \mathbf{a}. \quad (2.21.1)$$

This vector \mathbf{t}^A is called the *dual vector* of the antisymmetric tensor. It is also known as the *axial vector*. That such a vector indeed can be found is demonstrated here.

From Eq. (2.21.1), we have

$$\begin{aligned} T_{12} &= \mathbf{e}_1 \cdot \mathbf{T}\mathbf{e}_2 = \mathbf{e}_1 \cdot \mathbf{t}^A \times \mathbf{e}_2 = \mathbf{t}^A \cdot \mathbf{e}_2 \times \mathbf{e}_1 = -\mathbf{t}^A \cdot \mathbf{e}_3 = -t_3^A, \\ T_{31} &= \mathbf{e}_3 \cdot \mathbf{T}\mathbf{e}_1 = \mathbf{e}_3 \cdot \mathbf{t}^A \times \mathbf{e}_1 = \mathbf{t}^A \cdot \mathbf{e}_1 \times \mathbf{e}_3 = -\mathbf{t}^A \cdot \mathbf{e}_2 = -t_2^A, \\ T_{23} &= \mathbf{e}_2 \cdot \mathbf{T}\mathbf{e}_3 = \mathbf{e}_2 \cdot \mathbf{t}^A \times \mathbf{e}_3 = \mathbf{t}^A \cdot \mathbf{e}_3 \times \mathbf{e}_2 = -\mathbf{t}^A \cdot \mathbf{e}_1 = -t_1^A. \end{aligned} \quad (2.21.2)$$

Similar derivations will give $T_{21} = t_3^A$, $T_{13} = t_2^A$, $T_{32} = t_1^A$ and $T_{11} = T_{22} = T_{33} = 0$. Thus, only an antisymmetric tensor has a dual vector defined by Eq. (2.21.1). It is given by

$$\mathbf{t}^A = -(T_{23}\mathbf{e}_1 + T_{31}\mathbf{e}_2 + T_{12}\mathbf{e}_3) = T_{32}\mathbf{e}_1 + T_{13}\mathbf{e}_2 + T_{21}\mathbf{e}_3 \quad (2.21.3)$$

or, in indicial notation,

$$2\mathbf{t}^A = -\varepsilon_{ijk}T_{jk}\mathbf{e}_i. \quad (2.21.4)$$

The calculations of dual vectors have several uses. For example, it allows us to easily obtain the axis of rotation for a finite rotation tensor. In fact, the axis of rotation is parallel to the dual vector of the

antisymmetric part of the rotation tensor (see Example 2.21.2). Also, in Chapter 3 it will be shown that the dual vector can be used to obtain the infinitesimal angles of rotation of material elements under infinitesimal deformation (Section 3.11) and to obtain the angular velocity of material elements in general motion (Section 3.14).

Example 2.21.1

Given

$$[\mathbf{T}] = \begin{bmatrix} 1 & 2 & 3 \\ 4 & 2 & 1 \\ 1 & 1 & 1 \end{bmatrix}.$$

- (a) Decompose the tensor into a symmetric and an antisymmetric part.
- (b) Find the dual vector for the antisymmetric part.
- (c) Verify $\mathbf{T}^A \mathbf{a} = \mathbf{t}^A \times \mathbf{a}$ for $\mathbf{a} = \mathbf{e}_1 + \mathbf{e}_3$.

Solution

- (a) $[\mathbf{T}] = [\mathbf{T}^S] + [\mathbf{T}^A]$, where

$$[\mathbf{T}^S] = \frac{[\mathbf{T}] + [\mathbf{T}]^T}{2} = \begin{bmatrix} 1 & 3 & 2 \\ 3 & 2 & 1 \\ 2 & 1 & 1 \end{bmatrix}, [\mathbf{T}^A] = \frac{[\mathbf{T}] - [\mathbf{T}]^T}{2} = \begin{bmatrix} 0 & -1 & 1 \\ 1 & 0 & 0 \\ -1 & 0 & 0 \end{bmatrix}.$$

- (b) The dual vector of \mathbf{T}^A is

$$\mathbf{t}^A = -(T_{23}^A \mathbf{e}_1 + T_{31}^A \mathbf{e}_2 + T_{12}^A \mathbf{e}_3) = -(0\mathbf{e}_1 - \mathbf{e}_2 - \mathbf{e}_3) = \mathbf{e}_2 + \mathbf{e}_3.$$

- (c) Let $\mathbf{b} = \mathbf{T}^A \mathbf{a}$. Then

$$[\mathbf{b}] = \begin{bmatrix} 0 & -1 & 1 \\ 1 & 0 & 0 \\ -1 & 0 & 0 \end{bmatrix} \begin{bmatrix} 1 \\ 0 \\ 1 \end{bmatrix} = \begin{bmatrix} 1 \\ 1 \\ -1 \end{bmatrix},$$

that is,

$$\mathbf{b} = \mathbf{e}_1 + \mathbf{e}_2 - \mathbf{e}_3.$$

We note that $\mathbf{t}^A \times \mathbf{a} = (\mathbf{e}_2 + \mathbf{e}_3) \times (\mathbf{e}_1 + \mathbf{e}_3) = -\mathbf{e}_3 + \mathbf{e}_1 + \mathbf{e}_2 = \mathbf{b}$.

Example 2.21.2

Given that \mathbf{R} is a rotation tensor and that \mathbf{m} is a unit vector in the direction of the axis of rotation, prove that the dual vector \mathbf{q} of \mathbf{R}^A is parallel to \mathbf{m} .

Solution

Since \mathbf{m} is parallel to the axis of rotation, therefore,

$$\mathbf{R}\mathbf{m} = \mathbf{m}.$$

Multiplying the preceding equation by \mathbf{R}^T and noticing that $\mathbf{R}^T \mathbf{R} = \mathbf{I}$, we then also have the equation $\mathbf{R}^T \mathbf{m} = \mathbf{m}$. Thus,

$$(\mathbf{R} - \mathbf{R}^T)\mathbf{m} = \mathbf{0} \quad \text{or} \quad 2\mathbf{R}^A \mathbf{m} = \mathbf{0},$$

but $\mathbf{R}^A \mathbf{m} = \mathbf{q} \times \mathbf{m}$, where \mathbf{q} is the dual vector of \mathbf{R}^A . Therefore,

$$\mathbf{q} \times \mathbf{m} = \mathbf{0}, \quad (2.21.5)$$

that is, \mathbf{q} is parallel to \mathbf{m} . We note that it can be shown [see Prob. 2.54(b)] that if θ denotes the right-hand rotation angle, then

$$\mathbf{q} = (\sin \theta) \mathbf{m}. \quad (2.21.6)$$

2.22 EIGENVALUES AND EIGENVECTORS OF A TENSOR

Consider a tensor \mathbf{T} . If \mathbf{a} is a vector that transforms under \mathbf{T} into a vector parallel to itself, that is,

$$\mathbf{T}\mathbf{a} = \lambda \mathbf{a}, \quad (2.22.1)$$

then \mathbf{a} is an *eigenvector* and λ is the corresponding *eigenvalue*.

If \mathbf{a} is an eigenvector with corresponding eigenvalue λ of the linear transformation \mathbf{T} , any vector parallel to \mathbf{a} is also an eigenvector with the same eigenvalue λ . In fact, for any scalar α

$$\mathbf{T}(\alpha \mathbf{a}) = \alpha \mathbf{T}\mathbf{a} = \alpha(\lambda \mathbf{a}) = \lambda(\alpha \mathbf{a}). \quad (2.22.2)$$

Thus, an eigenvector, as defined by Eq. (2.22.1), has an arbitrary length. For definiteness, *we shall agree that all eigenvectors sought will be of unit length*.

A tensor may have infinitely many eigenvectors. In fact, since $\mathbf{I}\mathbf{a} = \mathbf{a}$, any vector is an eigenvector for the identity tensor \mathbf{I} , with eigenvalues all equal to unity. For the tensor $\beta \mathbf{I}$, the same is true except that the eigenvalues are all equal to β .

Some tensors only have eigenvectors in one direction. For example, for any rotation tensor that effects a rigid body rotation about an axis through an angle not equal to an integral multiple of π , only those vectors that are parallel to the axis of rotation will remain parallel to themselves.

Let \mathbf{n} be a unit eigenvector. Then

$$\mathbf{T}\mathbf{n} = \lambda \mathbf{n} = \lambda \mathbf{I}\mathbf{n}, \quad (2.22.3)$$

thus,

$$(\mathbf{T} - \lambda \mathbf{I})\mathbf{n} = \mathbf{0} \quad \text{with} \quad \mathbf{n} \cdot \mathbf{n} = 1. \quad (2.22.4)$$

Let $\mathbf{n} = \alpha_i \mathbf{e}_i$; then, in component form,

$$(T_{ij} - \lambda \delta_{ij})\alpha_j = 0 \quad \text{with} \quad \alpha_j \alpha_j = 1. \quad (2.22.5)$$

In long form, we have

$$\begin{aligned} (T_{11} - \lambda)\alpha_1 + T_{12}\alpha_2 + T_{13}\alpha_3 &= 0, \\ T_{21}\alpha_1 + (T_{22} - \lambda)\alpha_2 + T_{23}\alpha_3 &= 0, \\ T_{31}\alpha_1 + T_{32}\alpha_2 + (T_{33} - \lambda)\alpha_3 &= 0. \end{aligned} \quad (2.22.6)$$

Equations (2.22.6) are a system of linear homogeneous equations in α_1 , α_2 and α_3 . Obviously, a solution for this system is $\alpha_1 = \alpha_2 = \alpha_3 = 0$. This is known as the *trivial solution*. This solution simply states the

obvious fact that $\mathbf{a} = \mathbf{0}$ satisfies the equation $\mathbf{T}\mathbf{a} = \lambda\mathbf{a}$, independent of the value of λ . To find the nontrivial eigenvectors for \mathbf{T} , we note that a system of homogeneous, linear equations admits a nontrivial solution only if the determinant of its coefficients vanishes. That is,

$$|\mathbf{T} - \lambda\mathbf{I}| = 0, \quad (2.22.7)$$

that is,

$$\begin{vmatrix} T_{11} - \lambda & T_{12} & T_{13} \\ T_{21} & T_{22} - \lambda & T_{23} \\ T_{31} & T_{32} & T_{33} - \lambda \end{vmatrix} = 0. \quad (2.22.8)$$

Expanding the determinant results in a cubic equation in λ . It is called the *characteristic equation* of \mathbf{T} . The roots of this characteristic equation are the *eigenvalues* of \mathbf{T} .

Equations (2.22.6), together with the equation

$$\alpha_1^2 + \alpha_2^2 + \alpha_3^2 = 1, \quad (2.22.9)$$

allow us to obtain eigenvectors of unit length. The procedure for finding the eigenvalues and eigenvectors of a tensor are best illustrated by example.

Example 2.22.1

Find the eigenvalues and eigenvectors for the tensor whose components are

$$[\mathbf{T}] = \begin{bmatrix} 2 & 0 & 0 \\ 0 & 2 & 0 \\ 0 & 0 & 2 \end{bmatrix}.$$

Solution

We note that this tensor is $2\mathbf{I}$, so that $\mathbf{T}\mathbf{a} = 2\mathbf{I}\mathbf{a} = 2\mathbf{a}$ for any vector \mathbf{a} . Therefore, by the definition of eigenvector [see Eq. (2.22.1)], any direction is a direction for an eigenvector. The eigenvalue for every direction is the same, which is 2. However, we can also use Eq. (2.22.8) to find the eigenvalues and Eqs. (2.22.6) to find the eigenvectors. Indeed, Eq. (2.22.8) gives, for this tensor, the following characteristic equation:

$$(2 - \lambda)^3 = 0,$$

so we have a triple root $\lambda = 2$. Substituting this value in Eqs. (2.22.6), we have

$$(2 - 2)\alpha_1 = 0, \quad (2 - 2)\alpha_2 = 0, \quad (2 - 2)\alpha_3 = 0.$$

Thus, all three equations are automatically satisfied for arbitrary values of α_1 , α_2 and α_3 so that every direction is a direction for an eigenvector. We can choose any three noncoplanar directions as the three independent eigenvectors; on them all other eigenvectors depend. In particular, we can choose $\{\mathbf{e}_1, \mathbf{e}_2, \mathbf{e}_3\}$ as a set of independent eigenvectors.

Example 2.22.2

Show that if $T_{21} = T_{31} = 0$, then $\pm\mathbf{e}_1$ are eigenvectors of \mathbf{T} with eigenvalue T_{11} .

Solution

From $\mathbf{T}\mathbf{e}_1 = T_{11}\mathbf{e}_1 + T_{21}\mathbf{e}_2 + T_{31}\mathbf{e}_3$, we have

$$\mathbf{T}\mathbf{e}_1 = T_{11}\mathbf{e}_1 \quad \text{and} \quad \mathbf{T}(-\mathbf{e}_1) = T_{11}(-\mathbf{e}_1).$$

Thus, by definition, Eq. (2.22.1), $\pm\mathbf{e}_1$ are eigenvectors with T_{11} as its eigenvalue. Similarly, if $T_{12} = T_{32} = 0$, then $\pm\mathbf{e}_2$ are eigenvectors with corresponding eigenvalue T_{22} , and if $T_{13} = T_{23} = 0$, then $\pm\mathbf{e}_3$ are eigenvectors with corresponding eigenvalue T_{33} .

Example 2.22.3

Given that

$$[\mathbf{T}] = \begin{bmatrix} 2 & 0 & 0 \\ 0 & 2 & 0 \\ 0 & 0 & 3 \end{bmatrix}.$$

Find the eigenvalues and their corresponding eigenvectors.

Solution

The characteristic equation is

$$(2 - \lambda)^2(3 - \lambda) = 0.$$

Thus, $\lambda_1 = 3$, $\lambda_2 = \lambda_3 = 2$ (obviously the ordering of the eigenvalues is arbitrary). These results are obvious in view of Example 2.22.2. In fact, that example also tells us that the eigenvectors corresponding to $\lambda_1 = 3$ are $\pm\mathbf{e}_3$ and eigenvectors corresponding to $\lambda_2 = \lambda_3 = 2$ are $\pm\mathbf{e}_1$ and $\pm\mathbf{e}_2$. However, there are actually infinitely many eigenvectors corresponding to the double root. In fact, since

$$\mathbf{T}\mathbf{e}_1 = 2\mathbf{e}_1 \quad \text{and} \quad \mathbf{T}\mathbf{e}_2 = 2\mathbf{e}_2,$$

therefore, for any α and β ,

$$\mathbf{T}(\alpha\mathbf{e}_1 + \beta\mathbf{e}_2) = \alpha\mathbf{T}\mathbf{e}_1 + \beta\mathbf{T}\mathbf{e}_2 = 2\alpha\mathbf{e}_1 + 2\beta\mathbf{e}_2 = 2(\alpha\mathbf{e}_1 + \beta\mathbf{e}_2),$$

that is, $\alpha\mathbf{e}_1 + \beta\mathbf{e}_2$ is an eigenvector with eigenvalue 2. This fact can also be obtained from Eqs. (2.22.6). With $\lambda = 2$, these equations give

$$0\alpha_1 = 0, \quad 0\alpha_2 = 0, \quad \alpha_3 = 0.$$

Thus, $\alpha_1 = \text{arbitrary}$, $\alpha_2 = \text{arbitrary}$, and $\alpha_3 = 0$, so that any vector perpendicular to \mathbf{e}_3 , that is, any $\mathbf{n} = \alpha_1\mathbf{e}_1 + \alpha_2\mathbf{e}_2$, is an eigenvector.

Example 2.22.4

Find the eigenvalues and eigenvectors for the tensor

$$[\mathbf{T}] = \begin{bmatrix} 2 & 0 & 0 \\ 0 & 3 & 4 \\ 0 & 4 & -3 \end{bmatrix}.$$

Solution

The characteristic equation gives

$$|\mathbf{T} - \lambda\mathbf{I}| = \begin{vmatrix} 2 - \lambda & 0 & 0 \\ 0 & 3 - \lambda & 4 \\ 0 & 4 & -3 - \lambda \end{vmatrix} = (2 - \lambda)(\lambda^2 - 25) = 0.$$

Thus, there are three distinct eigenvalues, $\lambda_1 = 2$, $\lambda_2 = 5$ and $\lambda_3 = -5$.

Corresponding to $\lambda_1 = 2$, Eqs. (2.22.6) gives

$$0\alpha_1 = 0, \quad \alpha_2 + 4\alpha_3 = 0, \quad 4\alpha_2 - 5\alpha_3 = 0,$$

and we also have Eq. (2.22.9):

$$\alpha_1^2 + \alpha_2^2 + \alpha_3^2 = 1.$$

Thus, $\alpha_2 = \alpha_3 = 0$ and $\alpha_1 = \pm 1$ so that the eigenvector corresponding to $\lambda_1 = 2$ is

$$\mathbf{n}_1 = \pm \mathbf{e}_1.$$

We note that from the Example 2.22.2, this eigenvalue 2 and the corresponding eigenvectors $\mathbf{n}_1 = \pm \mathbf{e}_1$ can be written by inspection.

Corresponding to $\lambda_2 = 5$, we have

$$-3\alpha_1 = 0, \quad -2\alpha_2 + 4\alpha_3 = 0, \quad 4\alpha_2 - 8\alpha_3 = 0,$$

thus (note the second and third equations are the same),

$$\alpha_1 = 0, \quad \alpha_2 = 2\alpha_3,$$

and the unit eigenvectors corresponding to $\lambda_2 = 5$ are

$$\mathbf{n}_2 = \pm \frac{1}{\sqrt{5}}(2\mathbf{e}_2 + \mathbf{e}_3).$$

Similarly for $\lambda_3 = -5$, the unit eigenvectors are

$$\mathbf{n}_3 = \pm \frac{1}{\sqrt{5}}(-\mathbf{e}_2 + 2\mathbf{e}_3).$$

All the examples given here have three eigenvalues that are real. It can be shown that if a tensor is real (i.e., with real components) and symmetric, then all its eigenvalues are real. If a tensor is real but not symmetric, then two of the eigenvalues may be complex conjugates. The following is such an example.

Example 2.22.5

Find the eigenvalues and eigenvectors for the rotation tensor \mathbf{R} corresponding to a 90° rotation about the \mathbf{e}_3 (see Example 2.10.1).

Solution

With

$$[\mathbf{R}] = \begin{bmatrix} 0 & -1 & 0 \\ 1 & 0 & 0 \\ 0 & 0 & 1 \end{bmatrix},$$

the characteristic equation is

$$\begin{vmatrix} 0 - \lambda & -1 & 0 \\ 1 & 0 - \lambda & 0 \\ 0 & 0 & 1 - \lambda \end{vmatrix} = 0,$$

that is,

$$\lambda^2(1 - \lambda) + (1 - \lambda) = (1 - \lambda)(\lambda^2 + 1) = 0.$$

Thus, only one eigenvalue is real, namely $\lambda_1 = 1$; the other two, $\lambda_2 = +\sqrt{-1}$ and $\lambda_3 = -\sqrt{-1}$, are imaginary. Only real eigenvalues are of interest to us. We shall therefore compute only the eigenvector corresponding to $\lambda_1 = 1$. From

$$(0 - 1)\alpha_1 - \alpha_2 = 0, \quad \alpha_1 - \alpha_2 = 0, \quad (1 - 1)\alpha_3 = 0,$$

and

$$\alpha_1^2 + \alpha_2^2 + \alpha_3^2 = 1,$$

we obtain $\alpha_1 = 0$, $\alpha_2 = 0$, $\alpha_3 = \pm 1$, that is,

$$\mathbf{n} = \pm \mathbf{e}_3,$$

which, of course, are parallel to the axis of rotation.

2.23 PRINCIPAL VALUES AND PRINCIPAL DIRECTIONS OF REAL SYMMETRIC TENSORS

In the following chapters, we shall encounter several real tensors (stress tensor, strain tensor, rate of deformation tensor, etc.) that are symmetric. The following significant theorem can be proven: *The eigenvalues of any real symmetric tensor are all real* (we omit the proof). Thus, for a real symmetric tensor, there always exist at least three real eigenvectors, which we shall also call the *principal directions*. The corresponding eigenvalues are called the *principal values*.

We now prove that there always exist three principal directions that are mutually perpendicular. Let \mathbf{n}_1 and \mathbf{n}_2 be two eigenvectors corresponding to the eigenvalues λ_1 and λ_2 , respectively, of a tensor \mathbf{T} . Then

$$\mathbf{T}\mathbf{n}_1 = \lambda_1\mathbf{n}_1, \tag{2.23.1}$$

and

$$\mathbf{T}\mathbf{n}_2 = \lambda_2\mathbf{n}_2. \tag{2.23.2}$$

Thus,

$$\mathbf{n}_2 \cdot \mathbf{T}\mathbf{n}_1 = \lambda_1\mathbf{n}_2 \cdot \mathbf{n}_1, \tag{2.23.3}$$

and

$$\mathbf{n}_1 \cdot \mathbf{T}\mathbf{n}_2 = \lambda_2 \mathbf{n}_1 \cdot \mathbf{n}_2. \quad (2.23.4)$$

For a symmetric tensor, $\mathbf{T} = \mathbf{T}^T$, so that

$$\mathbf{n}_1 \cdot \mathbf{T}\mathbf{n}_2 = \mathbf{n}_2 \cdot \mathbf{T}^T \mathbf{n}_1 = \mathbf{n}_2 \cdot \mathbf{T}\mathbf{n}_1. \quad (2.23.5)$$

Thus, from Eqs. (2.23.3) and (2.23.4), we have

$$(\lambda_1 - \lambda_2)(\mathbf{n}_1 \cdot \mathbf{n}_2) = 0. \quad (2.23.6)$$

It follows that if λ_1 is not equal to λ_2 , then $\mathbf{n}_1 \cdot \mathbf{n}_2 = 0$, that is, \mathbf{n}_1 and \mathbf{n}_2 are perpendicular to each other. We have thus proved that if the eigenvalues of a symmetric tensor are all distinct, then *the three principal directions are mutually perpendicular*.

Next, let us suppose that \mathbf{n}_1 and \mathbf{n}_2 are two eigenvectors corresponding to the same eigenvalue λ . Then, by definition, $\mathbf{T}\mathbf{n}_1 = \lambda\mathbf{n}_1$ and $\mathbf{T}\mathbf{n}_2 = \lambda\mathbf{n}_2$ so that for any α and β ,

$$\mathbf{T}(\alpha\mathbf{n}_1 + \beta\mathbf{n}_2) = \alpha\mathbf{T}\mathbf{n}_1 + \beta\mathbf{T}\mathbf{n}_2 = \alpha\lambda\mathbf{n}_1 + \beta\lambda\mathbf{n}_2 = \lambda(\alpha\mathbf{n}_1 + \beta\mathbf{n}_2).$$

That is, $(\alpha\mathbf{n}_1 + \beta\mathbf{n}_2)$ is also an eigenvector with the same eigenvalue λ . In other words, if there are two distinct eigenvectors with the same eigenvalue, then there are infinitely many eigenvectors (which form a plane) with the same eigenvalue. This situation arises when the characteristic equation has a repeated root (see Example 2.22.3). Suppose the characteristic equation has roots $\lambda_1 = \lambda_2 = \lambda$ and λ_3 (λ_3 distinct from λ). Let \mathbf{n}_3 be the eigenvector corresponding to λ_3 ; then \mathbf{n}_3 is perpendicular to any eigenvector of λ . Therefore there exist infinitely many sets of three mutually perpendicular principal directions, each containing \mathbf{n}_3 and any two mutually perpendicular eigenvectors of the repeated root λ .

In the case of a triple root, $\lambda_1 = \lambda_2 = \lambda_3 = \lambda$, any vector is an eigenvector (see Example 2.22.1) so that there exist infinitely many sets of three mutually perpendicular principal directions.

From these discussions, we conclude that for every real symmetric tensor there exists at least one triad of principal directions that are mutually perpendicular.

2.24 MATRIX OF A TENSOR WITH RESPECT TO PRINCIPAL DIRECTIONS

We have shown that for a real symmetric tensor, there always exist three principal directions that are mutually perpendicular. Let \mathbf{n}_1 , \mathbf{n}_2 and \mathbf{n}_3 be unit vectors in these directions. Then, using \mathbf{n}_1 , \mathbf{n}_2 and \mathbf{n}_3 as base vectors, the components of the tensor are

$$\begin{aligned} T_{11} &= \mathbf{n}_1 \cdot \mathbf{T}\mathbf{n}_1 = \mathbf{n}_1 \cdot \lambda_1 \mathbf{n}_1 = \lambda_1 \mathbf{n}_1 \cdot \mathbf{n}_1 = \lambda_1, \\ T_{22} &= \mathbf{n}_2 \cdot \mathbf{T}\mathbf{n}_2 = \mathbf{n}_2 \cdot \lambda_2 \mathbf{n}_2 = \lambda_2 \mathbf{n}_2 \cdot \mathbf{n}_2 = \lambda_2, \\ T_{33} &= \mathbf{n}_3 \cdot \mathbf{T}\mathbf{n}_3 = \mathbf{n}_3 \cdot \lambda_3 \mathbf{n}_3 = \lambda_3 \mathbf{n}_3 \cdot \mathbf{n}_3 = \lambda_3, \\ T_{12} &= \mathbf{n}_1 \cdot \mathbf{T}\mathbf{n}_2 = \mathbf{n}_1 \cdot \lambda_2 \mathbf{n}_2 = \lambda_2 \mathbf{n}_1 \cdot \mathbf{n}_2 = 0, \\ T_{13} &= \mathbf{n}_1 \cdot \mathbf{T}\mathbf{n}_3 = \mathbf{n}_1 \cdot \lambda_3 \mathbf{n}_3 = \lambda_3 \mathbf{n}_1 \cdot \mathbf{n}_3 = 0, \\ T_{23} &= \mathbf{n}_2 \cdot \mathbf{T}\mathbf{n}_3 = \mathbf{n}_2 \cdot \lambda_3 \mathbf{n}_3 = \lambda_3 \mathbf{n}_2 \cdot \mathbf{n}_3 = 0, \end{aligned} \quad (2.24.1)$$

that is,

$$[\mathbf{T}] = \begin{bmatrix} \lambda_1 & 0 & 0 \\ 0 & \lambda_2 & 0 \\ 0 & 0 & \lambda_3 \end{bmatrix}_{\mathbf{n}_i}. \quad (2.24.2)$$

Thus, the matrix is diagonal and the diagonal elements are the eigenvalues of \mathbf{T} .

We now show that the principal values of a tensor \mathbf{T} include the maximum and the minimum values that the diagonal elements of any matrix of \mathbf{T} can have. First, for any unit vector $\mathbf{e}'_1 = \alpha\mathbf{n}_1 + \beta\mathbf{n}_2 + \gamma\mathbf{n}_3$,

$$T'_{11} = \mathbf{e}'_1 \cdot \mathbf{T} \mathbf{e}'_1 = [\alpha \quad \beta \quad \gamma] \begin{bmatrix} \lambda_1 & 0 & 0 \\ 0 & \lambda_2 & 0 \\ 0 & 0 & \lambda_3 \end{bmatrix} \begin{bmatrix} \alpha \\ \beta \\ \gamma \end{bmatrix}, \quad (2.24.3)$$

that is,

$$T'_{11} = \lambda_1 \alpha^2 + \lambda_2 \beta^2 + \lambda_3 \gamma^2. \quad (2.24.4)$$

Without loss of generality, let

$$\lambda_1 \geq \lambda_2 \geq \lambda_3. \quad (2.24.5)$$

Then, noting that $\alpha^2 + \beta^2 + \gamma^2 = 1$, we have

$$\lambda_1 = \lambda_1(\alpha^2 + \beta^2 + \gamma^2) \geq \lambda_1 \alpha^2 + \lambda_2 \beta^2 + \lambda_3 \gamma^2, \quad (2.24.6)$$

that is,

$$\lambda_1 \geq T'_{11}. \quad (2.24.7)$$

We also have

$$\lambda_1 \alpha^2 + \lambda_2 \beta^2 + \lambda_3 \gamma^2 \geq \lambda_3(\alpha^2 + \beta^2 + \gamma^2) = \lambda_3, \quad (2.24.8)$$

that is,

$$T'_{11} \geq \lambda_3. \quad (2.24.9)$$

Thus, the maximum value of the principal values of \mathbf{T} is the maximum value of the diagonal elements of *all matrices* of \mathbf{T} , and the minimum value of the principal values of \mathbf{T} is the minimum value of the diagonal elements of *all matrices* of \mathbf{T} . It is important to remember that for a given \mathbf{T} , there are infinitely many matrices and therefore, infinitely many diagonal elements, of which the maximum principal value is the maximum of all of them and the minimum principal value is the minimum of all of them.

2.25 PRINCIPAL SCALAR INVARIANTS OF A TENSOR

The characteristic equation of a tensor \mathbf{T} , $|T_{ij} - \lambda \delta_{ij}| = 0$ can be written as:

$$\lambda^3 - I_1 \lambda^2 + I_2 \lambda - I_3 = 0, \quad (2.25.1)$$

where

$$I_1 = T_{11} + T_{22} + T_{33} = T_{ii} = \text{tr} \mathbf{T}, \quad (2.25.2)$$

$$I_2 = \begin{vmatrix} T_{11} & T_{12} \\ T_{21} & T_{22} \end{vmatrix} + \begin{vmatrix} T_{22} & T_{23} \\ T_{32} & T_{33} \end{vmatrix} + \begin{vmatrix} T_{11} & T_{13} \\ T_{31} & T_{33} \end{vmatrix} = \frac{1}{2} (T_{ii} T_{jj} - T_{ij} T_{ji}) = \frac{1}{2} [(\text{tr} \mathbf{T})^2 - \text{tr}(\mathbf{T}^2)], \quad (2.25.3)$$

$$I_3 = \begin{vmatrix} T_{11} & T_{12} & T_{13} \\ T_{21} & T_{22} & T_{23} \\ T_{31} & T_{32} & T_{33} \end{vmatrix} = \det [\mathbf{T}]. \quad (2.25.4)$$

Since by definition, the eigenvalues of \mathbf{T} do not depend on the choices of the base vectors, therefore the coefficients of Eq. (2.25.1) will not depend on any particular choices of basis. They are called the *principal scalar invariants* of \mathbf{T} .

We note that, in terms of the eigenvalues of \mathbf{T} , which are the roots of Eq. (2.25.1), the scalar invariants take the simple form

$$\begin{aligned} I_1 &= \lambda_1 + \lambda_2 + \lambda_3, \\ I_2 &= \lambda_1\lambda_2 + \lambda_2\lambda_3 + \lambda_3\lambda_1, \\ I_3 &= \lambda_1\lambda_2\lambda_3. \end{aligned} \quad (2.25.5)$$

Example 2.25.1

For the tensor of Example 2.22.4, first find the principal scalar invariants and then evaluate the eigenvalues using Eq. (2.25.1).

Solution

The matrix of \mathbf{T} is

$$[\mathbf{T}] = \begin{bmatrix} 2 & 0 & 0 \\ 0 & 3 & 4 \\ 0 & 4 & -3 \end{bmatrix}.$$

Thus,

$$\begin{aligned} I_1 &= 2 + 3 - 3 = 2, \\ I_2 &= \begin{vmatrix} 2 & 0 \\ 0 & 3 \end{vmatrix} + \begin{vmatrix} 3 & 4 \\ 4 & -3 \end{vmatrix} + \begin{vmatrix} 2 & 0 \\ 0 & -3 \end{vmatrix} = -25, \\ I_3 &= |\mathbf{T}| = -50. \end{aligned}$$

These values give the characteristic equation as

$$\lambda^3 - 2\lambda^2 - 25\lambda + 50 = 0,$$

or

$$(\lambda - 2)(\lambda - 5)(\lambda + 5) = 0.$$

Thus the eigenvalues are $\lambda = 2$, $\lambda = 5$ and $\lambda = -5$, as previously determined.

PROBLEMS FOR PART B

- 2.19** A transformation \mathbf{T} operates on any vector \mathbf{a} to give $\mathbf{T}\mathbf{a} = \mathbf{a}/|\mathbf{a}|$, where $|\mathbf{a}|$ is the magnitude of \mathbf{a} . Show that \mathbf{T} is not a linear transformation.
- 2.20** (a) A tensor \mathbf{T} transforms every vector \mathbf{a} into a vector $\mathbf{T}\mathbf{a} = \mathbf{m} \times \mathbf{a}$, where \mathbf{m} is a specified vector. Show that \mathbf{T} is a linear transformation. (b) If $\mathbf{m} = \mathbf{e}_1 + \mathbf{e}_2$, find the matrix of the tensor \mathbf{T} .
- 2.21** A tensor \mathbf{T} transforms the base vectors \mathbf{e}_1 and \mathbf{e}_2 such that $\mathbf{T}\mathbf{e}_1 = \mathbf{e}_1 + \mathbf{e}_2$, $\mathbf{T}\mathbf{e}_2 = \mathbf{e}_1 - \mathbf{e}_2$. If $\mathbf{a} = 2\mathbf{e}_1 + 3\mathbf{e}_2$ and $\mathbf{b} = 3\mathbf{e}_1 + 2\mathbf{e}_2$, use the linear property of \mathbf{T} to find (a) $\mathbf{T}\mathbf{a}$, (b) $\mathbf{T}\mathbf{b}$, and (c) $\mathbf{T}(\mathbf{a}+\mathbf{b})$.
- 2.22** Obtain the matrix for the tensor \mathbf{T} , that transforms the base vectors as follows: $\mathbf{T}\mathbf{e}_1 = 2\mathbf{e}_1 + \mathbf{e}_3$, $\mathbf{T}\mathbf{e}_2 = \mathbf{e}_2 + 3\mathbf{e}_3$, $\mathbf{T}\mathbf{e}_3 = -\mathbf{e}_1 + 3\mathbf{e}_2$.
- 2.23** Find the matrix of the tensor \mathbf{T} that transforms any vector \mathbf{a} into a vector $\mathbf{b} = \mathbf{m}(\mathbf{a} \cdot \mathbf{n})$ where $\mathbf{m} = \frac{\sqrt{2}}{2}(\mathbf{e}_1 + \mathbf{e}_2)$ and $\mathbf{n} = \frac{\sqrt{2}}{2}(-\mathbf{e}_1 + \mathbf{e}_3)$.

- 2.24 (a) A tensor \mathbf{T} transforms every vector into its mirror image with respect to the plane whose normal is \mathbf{e}_2 . Find the matrix of \mathbf{T} . (b) Do part (a) if the plane has a normal in the \mathbf{e}_3 direction.
- 2.25 (a) Let \mathbf{R} correspond to a right-hand rotation of angle θ about the x_1 -axis. Find the matrix of \mathbf{R} . (b) Do part (a) if the rotation is about the x_2 -axis. The coordinates are right-handed.
- 2.26 Consider a plane of reflection that passes through the origin. Let \mathbf{n} be a unit normal vector to the plane and let \mathbf{r} be the position vector for a point in space. (a) Show that the reflected vector for \mathbf{r} is given by $\mathbf{Tr} = \mathbf{r} - 2(\mathbf{r} \cdot \mathbf{n})\mathbf{n}$, where \mathbf{T} is the transformation that corresponds to the reflection. (b) Let $\mathbf{n} = (\mathbf{e}_1 + \mathbf{e}_2 + \mathbf{e}_3)/\sqrt{3}$; find the matrix of \mathbf{T} . (c) Use this linear transformation to find the mirror image of the vector $\mathbf{a} = \mathbf{e}_1 + 2\mathbf{e}_2 + 3\mathbf{e}_3$.
- 2.27 Knowing that the reflected vector for \mathbf{r} is given by $\mathbf{Tr} = \mathbf{r} - 2(\mathbf{r} \cdot \mathbf{n})\mathbf{n}$ (see the previous problem), where \mathbf{T} is the transformation that corresponds to the reflection and \mathbf{n} is the normal to the mirror, show that in dyadic notation the reflection tensor is given by $\mathbf{T} = \mathbf{I} - 2\mathbf{nn}$ and find the matrix of \mathbf{T} if the normal of the mirror is given by $\mathbf{n} = (\mathbf{e}_1 + \mathbf{e}_2 + \mathbf{e}_3)/\sqrt{3}$.
- 2.28 A rotation tensor \mathbf{R} is defined by the relation $\mathbf{R}\mathbf{e}_1 = \mathbf{e}_2$, $\mathbf{R}\mathbf{e}_2 = \mathbf{e}_3$, $\mathbf{R}\mathbf{e}_3 = \mathbf{e}_1$. (a) Find the matrix of \mathbf{R} and verify that $\mathbf{R}^T\mathbf{R} = \mathbf{I}$ and $\det \mathbf{R} = 1$ and (b) find a unit vector in the direction of the axis of rotation that could have been used to effect this particular rotation.
- 2.29 A rigid body undergoes a right-hand rotation of angle θ about an axis that is in the direction of the unit vector \mathbf{m} . Let the origin of the coordinates be on the axis of rotation and \mathbf{r} be the position vector for a typical point in the body. (a) Show that the rotated vector of \mathbf{r} is given by: $\mathbf{Rr} = (1 - \cos\theta)(\mathbf{m} \cdot \mathbf{r})\mathbf{m} + \cos\theta\mathbf{r} + \sin\theta(\mathbf{m} \times \mathbf{r})$, where \mathbf{R} is the rotation tensor. (b) Let $\mathbf{m} = (\mathbf{e}_1 + \mathbf{e}_2 + \mathbf{e}_3)/\sqrt{3}$, find the matrix for \mathbf{R} .
- 2.30 For the rotation about an arbitrary axis \mathbf{m} by an angle θ , (a) show that the rotation tensor is given by $\mathbf{R} = (1 - \cos\theta)(\mathbf{mm}) + \cos\theta\mathbf{I} + \sin\theta\mathbf{E}$, where \mathbf{mm} denotes that dyadic product of \mathbf{m} and \mathbf{m} , and \mathbf{E} is the antisymmetric tensor whose dual vector (or axial vector) is \mathbf{m} , (b) find \mathbf{R}^A , the antisymmetric part of \mathbf{R} and (c) show that the dual vector for \mathbf{R}^A is given by $(\sin \theta)\mathbf{m}$. *Hint:* $\mathbf{Rr} = (1 - \cos\theta)(\mathbf{m} \cdot \mathbf{r})\mathbf{m} + \cos\theta\mathbf{r} + \sin\theta(\mathbf{m} \times \mathbf{r})$ (see previous problem).
- 2.31 (a) Given a mirror whose normal is in the direction of \mathbf{e}_2 , find the matrix of the tensor \mathbf{S} , which first transforms every vector into its mirror image and then transforms them by a 45° right-hand rotation about the \mathbf{e}_1 -axis. (b) Find the matrix of the tensor \mathbf{T} , which first transforms every vector by a 45° right-hand rotation about the \mathbf{e}_1 -axis and then transforms them by a reflection with respect to a mirror (with normal \mathbf{e}_2). (c) Consider the vector $\mathbf{a} = \mathbf{e}_1 + 2\mathbf{e}_2 + 3\mathbf{e}_3$; find the transformed vector by using the transformation \mathbf{S} . (d) For the same vector $\mathbf{a} = \mathbf{e}_1 + 2\mathbf{e}_2 + 3\mathbf{e}_3$, find the transformed vector by using the transformation \mathbf{T} .
- 2.32 Let \mathbf{R} correspond to a right-hand rotation of angle θ about the x_3 -axis; (a) find the matrix of \mathbf{R}^2 . (b) Show that \mathbf{R}^2 corresponds to a rotation of angle 2θ about the same axis. (c) Find the matrix of \mathbf{R}^n for any integer n .
- 2.33 Rigid body rotations that are small can be described by an orthogonal transformation $\mathbf{R} = \mathbf{I} + \varepsilon\mathbf{R}^*$, where $\varepsilon \rightarrow 0$ as the rotation angle approaches zero. Consider two successive small rotations, \mathbf{R}_1 and \mathbf{R}_2 ; show that the final result does not depend on the order of rotations.
- 2.34 Let \mathbf{T} and \mathbf{S} be any two tensors. Show that (a) \mathbf{T}^T is a tensor, (b) $\mathbf{T}^T + \mathbf{S}^T = (\mathbf{T} + \mathbf{S})^T$, and (c) $(\mathbf{TS})^T = \mathbf{S}^T\mathbf{T}^T$.
- 2.35 For arbitrary tensors \mathbf{T} and \mathbf{S} , without relying on the component form, prove that (a) $(\mathbf{T}^{-1})^T = (\mathbf{T}^T)^{-1}$ and (b) $(\mathbf{TS})^{-1} = \mathbf{S}^{-1}\mathbf{T}^{-1}$.

- 2.36** Let $\{\mathbf{e}_i\}$ and $\{\mathbf{e}'_i\}$ be two rectangular Cartesian base vectors. (a) Show that if $\mathbf{e}'_i = Q_{mi}\mathbf{e}_m$, then $\mathbf{e}_i = Q_{im}\mathbf{e}'_m$. (b) Verify $Q_{mi}Q_{mj} = \delta_{ij} = Q_{im}Q_{jm}$.
- 2.37** The basis $\{\mathbf{e}'_i\}$ is obtained by a 30° counterclockwise rotation of the $\{\mathbf{e}_i\}$ basis about the \mathbf{e}_3 axis. (a) Find the transformation matrix $[\mathbf{Q}]$ relating the two sets of basis. (b) By using the vector transformation law, find the components of $\mathbf{a} = \sqrt{3}\mathbf{e}_1 + \mathbf{e}_2$ in the primed basis, i.e., find a'_i and (c) do part (b) geometrically.
- 2.38** Do the previous problem with the $\{\mathbf{e}'_i\}$ basis obtained by a 30° clockwise rotation of the $\{\mathbf{e}_i\}$ basis about the \mathbf{e}_3 axis.
- 2.39** The matrix of a tensor \mathbf{T} with respect to the basis $\{\mathbf{e}_i\}$ is

$$[\mathbf{T}] = \begin{bmatrix} 1 & 5 & -5 \\ 5 & 0 & 0 \\ -5 & 0 & 1 \end{bmatrix}.$$

Find T'_{11} , T'_{12} and T'_{31} with respect to a right-handed basis $\{\mathbf{e}'_i\}$ where \mathbf{e}'_1 is in the direction of $-\mathbf{e}_2 + 2\mathbf{e}_3$ and \mathbf{e}'_2 is in the direction of \mathbf{e}_1 .

- 2.40** (a) For the tensor of the previous problem, find $[T'_{ij}]$, i.e., $[\mathbf{T}]_{\mathbf{e}'_i}$ where $\{\mathbf{e}'_i\}$ is obtained by a 90° right-hand rotation about the \mathbf{e}_3 axis and (b) obtain T'_{ii} and the determinant $|T'_{ij}|$ and compare them with T_{ii} and $|T_{ij}|$.
- 2.41** The dot product of two vectors $\mathbf{a} = a_i\mathbf{e}_i$ and $\mathbf{b} = b_i\mathbf{e}_i$ is equal to a_ib_i . Show that the dot product is a scalar invariant with respect to orthogonal transformations of coordinates.
- 2.42** If T_{ij} are the components of a tensor, (a) show that $T_{ij}T_{ij}$ is a scalar invariant with respect to orthogonal transformations of coordinates, (b) evaluate $T_{ij}T_{ij}$ with respect to the basis $\{\mathbf{e}_i\}$ for $[\mathbf{T}] = \begin{bmatrix} 1 & 0 & 0 \\ 1 & 2 & 5 \\ 1 & 2 & 3 \end{bmatrix}_{\mathbf{e}_i}$, (c) find $[\mathbf{T}]'$ if $\mathbf{e}'_i = \mathbf{Q}\mathbf{e}_i$, where $[\mathbf{Q}] = \begin{bmatrix} 0 & 0 & 1 \\ 1 & 0 & 0 \\ 0 & 1 & 0 \end{bmatrix}_{\mathbf{e}_i}$, and (d) verify for the above that $T'_{ij}T'_{ij} = T_{ij}T_{ij}$.
- 2.43** Let $[\mathbf{T}]$ and $[\mathbf{T}]'$ be two matrices of the same tensor \mathbf{T} . Show that $\det[\mathbf{T}] = \det[\mathbf{T}]'$.
- 2.44** (a) If the components of a third-order tensor are R_{ijk} , show that R_{ik} are components of a vector. (b) If the components of a fourth-order tensor are R_{ijkl} , show that R_{ikl} are components of a second-order tensor. (c) What are components of $R_{ik\dots}$ if $R_{ijk\dots}$ are components of a tensor of n^{th} order?
- 2.45** The components of an arbitrary vector \mathbf{a} and an arbitrary second tensor \mathbf{T} are related by a triply subscripted quantity R_{ijk} in the manner $a_i = R_{ijk}T_{jk}$ for any rectangular Cartesian basis $\{\mathbf{e}_i\}$. Prove that R_{ijk} are the components of a third-order tensor.
- 2.46** For any vector \mathbf{a} and any tensor \mathbf{T} , show that (a) $\mathbf{a} \cdot \mathbf{T}^A \mathbf{a} = 0$ and (b) $\mathbf{a} \cdot \mathbf{T} \mathbf{a} = \mathbf{a} \cdot \mathbf{T}^S \mathbf{a}$, where \mathbf{T}^A and \mathbf{T}^S are antisymmetric and symmetric part of \mathbf{T} , respectively.
- 2.47** Any tensor can be decomposed into a symmetric part and an antisymmetric part, that is, $\mathbf{T} = \mathbf{T}^S + \mathbf{T}^A$. Prove that the decomposition is unique. (*Hint*: Assume that it is not true and show contradiction.)
- 2.48** Given that a tensor \mathbf{T} has the matrix $[\mathbf{T}] = \begin{bmatrix} 1 & 2 & 3 \\ 4 & 5 & 6 \\ 7 & 8 & 9 \end{bmatrix}$, (a) find the symmetric part and the antisymmetric part of \mathbf{T} and (b) find the dual vector (or axial vector) of the antisymmetric part of \mathbf{T} .

2.49 Prove that the only possible real eigenvalues of an orthogonal tensor \mathbf{Q} are $\lambda = \pm 1$. Explain the direction of the eigenvectors corresponding to them for a proper orthogonal (rotation) tensor and for an improper orthogonal (reflection) tensor.

2.50 Given the improper orthogonal tensor $[\mathbf{Q}] = \frac{1}{3} \begin{bmatrix} 1 & -2 & -2 \\ -2 & 1 & -2 \\ -2 & -2 & 1 \end{bmatrix}$. (a) Verify that $\det [\mathbf{Q}] = -1$.

(b) Verify that the eigenvalues are $\lambda = 1$ and -1 . (c) Find the normal to the plane of reflection (i.e., eigenvectors corresponding to $\lambda = -1$) and (d) find the eigenvectors corresponding to $\lambda = 1$ (vectors parallel to the plane of reflection).

2.51 Given that tensors \mathbf{R} and \mathbf{S} have the same eigenvector \mathbf{n} and corresponding eigenvalues r_1 and s_1 , respectively, find an eigenvalue and the corresponding eigenvector for $\mathbf{T} = \mathbf{RS}$.

2.52 Show that if \mathbf{n} is a real eigenvector of an antisymmetric tensor \mathbf{T} , then the corresponding eigenvalue vanishes.

2.53 (a) Show that \mathbf{a} is an eigenvector for the dyadic product \mathbf{ab} of vectors \mathbf{a} and \mathbf{b} with eigenvalue $\mathbf{a} \cdot \mathbf{b}$, (b) find the first principal scalar invariant of the dyadic product \mathbf{ab} and (c) show that the second and the third principal scalar invariant of the dyadic product \mathbf{ab} vanish, and that zero is a double eigenvalue of \mathbf{ab} .

2.54 For any rotation tensor, a set of basis $\{\mathbf{e}'_i\}$ may be chosen with \mathbf{e}'_3 along the axis of rotation so that $\mathbf{R}\mathbf{e}'_1 = \cos\theta\mathbf{e}'_1 + \sin\theta\mathbf{e}'_2$, $\mathbf{R}\mathbf{e}'_2 = -\sin\theta\mathbf{e}'_1 + \cos\theta\mathbf{e}'_2$, $\mathbf{R}\mathbf{e}'_3 = \mathbf{e}'_3$, where θ is the angle of right-hand rotation. (a) Find the antisymmetric part of \mathbf{R} with respect to the basis $\{\mathbf{e}'_i\}$, i.e., find $[\mathbf{R}^\Lambda]_{\mathbf{e}'_i}$. (b) Show that the dual vector of \mathbf{R}^Λ is given by $\mathbf{t}^\Lambda = \sin\theta\mathbf{e}'_3$ and (c) show that the first scalar invariant of \mathbf{R} is given by $1 + 2\cos\theta$. That is, for any given rotation tensor \mathbf{R} , its axis of rotation and the angle of rotation can be obtained from the dual vector of \mathbf{R}^Λ and the first scalar invariant of \mathbf{R} .

2.55 The rotation of a rigid body is described by $\mathbf{R}\mathbf{e}_1 = \mathbf{e}_2$, $\mathbf{R}\mathbf{e}_2 = \mathbf{e}_3$, $\mathbf{R}\mathbf{e}_3 = \mathbf{e}_1$. Find the axis of rotation and the angle of rotation. Use the result of the previous problem.

2.56 Given the tensor $[\mathbf{Q}] = \begin{bmatrix} -1 & 0 & 0 \\ 0 & -1 & 0 \\ 0 & 0 & 1 \end{bmatrix}$. (a) Show that the given tensor is a rotation tensor. (b) Verify

that the eigenvalues are $\lambda = 1$ and -1 . (c) Find the direction for the axis of rotation (i.e., eigenvectors corresponding to $\lambda = 1$). (d) Find the eigenvectors corresponding to $\lambda = -1$ and (e) obtain the angle of rotation using the formula $I_1 = 1 + 2\cos\theta$ (see Prob. 2.54), where I_1 is the first scalar invariant of the rotation tensor.

2.57 Let \mathbf{F} be an arbitrary tensor. (a) Show that $\mathbf{F}^T\mathbf{F}$ and $\mathbf{F}\mathbf{F}^T$ are both symmetric tensors. (b) If $\mathbf{F} = \mathbf{Q}\mathbf{U} = \mathbf{V}\mathbf{Q}$, where \mathbf{Q} is orthogonal, show that $\mathbf{U}^2 = \mathbf{F}^T\mathbf{F}$ and $\mathbf{V}^2 = \mathbf{F}\mathbf{F}^T$. (c) If λ and \mathbf{n} are eigenvalue and the corresponding eigenvector for \mathbf{U} , find the eigenvalue and eigenvector for \mathbf{V} .

2.58 Verify that the second principal scalar invariant of a tensor \mathbf{T} can be written: $I_2 = \frac{T_{ii}T_{jj}}{2} - \frac{T_{ij}T_{ji}}{2}$.

2.59 A tensor \mathbf{T} has a matrix $[\mathbf{T}]$ given below. (a) Write the characteristic equation and find the principal values and their corresponding principal directions. (b) Find the principal scalar invariants. (c) If \mathbf{n}_1 , \mathbf{n}_2 , \mathbf{n}_3 are the principal directions, write $[\mathbf{T}]_{\mathbf{n}_i}$. (d) Could the following matrix $[\mathbf{S}]$ represent the same

tensor \mathbf{T} with respect to some basis? $[\mathbf{T}] = \begin{bmatrix} 5 & 4 & 0 \\ 4 & -1 & 0 \\ 0 & 0 & 3 \end{bmatrix}$, $[\mathbf{S}] = \begin{bmatrix} 7 & 2 & 0 \\ 2 & 1 & 0 \\ 0 & 0 & -1 \end{bmatrix}$.

2.60 Do the previous problem for the following matrix: $[\mathbf{T}] = \begin{bmatrix} 3 & 0 & 0 \\ 0 & 0 & 4 \\ 0 & 4 & 0 \end{bmatrix}$.

2.61 A tensor \mathbf{T} has a matrix given below. Find the principal values and three mutually perpendicular principal directions.

$$[\mathbf{T}] = \begin{bmatrix} 1 & 1 & 0 \\ 1 & 1 & 0 \\ 0 & 0 & 2 \end{bmatrix}.$$

PART C: TENSOR CALCULUS

2.26 TENSOR-VALUED FUNCTIONS OF A SCALAR

Let $\mathbf{T} = \mathbf{T}(t)$ be a tensor-valued function of a scalar t (such as time). The derivative of \mathbf{T} with respect to t is defined to be a second-order tensor given by:

$$\frac{d\mathbf{T}}{dt} = \lim_{\Delta t \rightarrow 0} \frac{\mathbf{T}(t + \Delta t) - \mathbf{T}(t)}{\Delta t}. \quad (2.26.1)$$

The following identities can be easily established:

$$\frac{d}{dt}(\mathbf{T} + \mathbf{S}) = \frac{d\mathbf{T}}{dt} + \frac{d\mathbf{S}}{dt}, \quad (2.26.2)$$

$$\frac{d}{dt}(\alpha(t)\mathbf{T}) = \frac{d\alpha}{dt}\mathbf{T} + \alpha \frac{d\mathbf{T}}{dt}, \quad (2.26.3)$$

$$\frac{d}{dt}(\mathbf{T}\mathbf{S}) = \frac{d\mathbf{T}}{dt}\mathbf{S} + \mathbf{T} \frac{d\mathbf{S}}{dt}, \quad (2.26.4)$$

$$\frac{d}{dt}(\mathbf{T}\mathbf{a}) = \frac{d\mathbf{T}}{dt}\mathbf{a} + \mathbf{T} \frac{d\mathbf{a}}{dt}, \quad (2.26.5)$$

$$\frac{d}{dt}(\mathbf{T}^T) = \left(\frac{d\mathbf{T}}{dt}\right)^T. \quad (2.26.6)$$

We shall prove here only Eq. (2.26.5). The other identities can be proven in a similar way. Using the definition given in Eq. (2.26.1), we have

$$\begin{aligned} \frac{d}{dt}(\mathbf{T}\mathbf{a}) &= \lim_{\Delta t \rightarrow 0} \frac{\mathbf{T}(t + \Delta t)\mathbf{a}(t + \Delta t) - \mathbf{T}(t)\mathbf{a}(t)}{\Delta t} \\ &= \lim_{\Delta t \rightarrow 0} \frac{\mathbf{T}(t + \Delta t)\mathbf{a}(t + \Delta t) - \mathbf{T}(t)\mathbf{a}(t) - \mathbf{T}(t)\mathbf{a}(t + \Delta t) + \mathbf{T}(t)\mathbf{a}(t + \Delta t)}{\Delta t} \\ &= \lim_{\Delta t \rightarrow 0} \frac{\mathbf{T}(t + \Delta t)\mathbf{a}(t + \Delta t) - \mathbf{T}(t)\mathbf{a}(t + \Delta t) + \mathbf{T}(t)\mathbf{a}(t + \Delta t) - \mathbf{T}(t)\mathbf{a}(t)}{\Delta t} \\ &= \lim_{\Delta t \rightarrow 0} \frac{\mathbf{T}(t + \Delta t) - \mathbf{T}(t)}{\Delta t} \mathbf{a}(t + \Delta t) + \lim_{\Delta t \rightarrow 0} \mathbf{T}(t) \frac{\mathbf{a}(t + \Delta t) - \mathbf{a}(t)}{\Delta t}. \end{aligned}$$

Thus,

$$\frac{d(\mathbf{T}\mathbf{a})}{dt} = \frac{d\mathbf{T}}{dt}\mathbf{a} + \mathbf{T} \frac{d\mathbf{a}}{dt}.$$

Example 2.26.1

Show that in Cartesian coordinates, the components of $d\mathbf{T}/dt$, i.e., $(d\mathbf{T}/dt)_{ij}$ are given by the derivatives of the components dT_{ij}/dt .

Solution

From

$$T_{ij} = \mathbf{e}_i \cdot \mathbf{T} \mathbf{e}_j,$$

we have

$$\frac{dT_{ij}}{dt} = \frac{d\mathbf{e}_i}{dt} \cdot \mathbf{T} \mathbf{e}_j + \mathbf{e}_i \cdot \frac{d\mathbf{T}}{dt} \mathbf{e}_j + \mathbf{e}_i \cdot \mathbf{T} \frac{d\mathbf{e}_j}{dt}.$$

Since the base vectors are fixed, their derivatives are zero; therefore,

$$\frac{dT_{ij}}{dt} = \mathbf{e}_i \cdot \frac{d\mathbf{T}}{dt} \mathbf{e}_j = \left(\frac{d\mathbf{T}}{dt} \right)_{ij}.$$

Example 2.26.2

Show that for an orthogonal tensor $\mathbf{Q}(t)$, $\left(\frac{d\mathbf{Q}}{dt} \right) \mathbf{Q}^T$ is an antisymmetric tensor.

Solution

Since $\mathbf{Q}\mathbf{Q}^T = \mathbf{I}$, we have

$$\frac{d(\mathbf{Q}\mathbf{Q}^T)}{dt} = \mathbf{Q} \frac{d\mathbf{Q}^T}{dt} + \frac{d\mathbf{Q}}{dt} \mathbf{Q}^T = \frac{d\mathbf{I}}{dt} = \mathbf{0}.$$

Since [see Eq. (2.26.6)] $\frac{d\mathbf{Q}^T}{dt} = \left(\frac{d\mathbf{Q}}{dt} \right)^T$, therefore, the above equation leads to

$$\mathbf{Q} \left(\frac{d\mathbf{Q}}{dt} \right)^T = - \frac{d\mathbf{Q}}{dt} \mathbf{Q}^T.$$

Now $\mathbf{Q} \left(\frac{d\mathbf{Q}}{dt} \right)^T = \left(\frac{d\mathbf{Q}}{dt} \mathbf{Q}^T \right)^T$; therefore,

$$\left(\frac{d\mathbf{Q}}{dt} \mathbf{Q}^T \right)^T = - \frac{d\mathbf{Q}}{dt} \mathbf{Q}^T,$$

that is, $\left(\frac{d\mathbf{Q}}{dt} \right) \mathbf{Q}^T$ is an antisymmetric tensor.

Example 2.26.3

A time-dependent rigid body rotation about a fixed point can be represented by a rotation tensor $\mathbf{R}(t)$, so that a position vector \mathbf{r}_0 is transformed through the rotation into $\mathbf{r}(t) = \mathbf{R}(t)\mathbf{r}_0$. Derive the equation

$$\frac{d\mathbf{r}}{dt} = \boldsymbol{\omega} \times \mathbf{r}, \quad (2.26.7)$$

where $\boldsymbol{\omega}$ is the dual vector of the antisymmetric tensor $\frac{d\mathbf{R}}{dt} \mathbf{R}^T$.

Solution

From $\mathbf{r}(t) = \mathbf{R}(t)\mathbf{r}_0$, we obtain

$$\frac{d\mathbf{r}}{dt} = \frac{d\mathbf{R}}{dt} \mathbf{r}_0 = \frac{d\mathbf{R}}{dt} \mathbf{R}^{-1} \mathbf{r} = \frac{d\mathbf{R}}{dt} \mathbf{R}^T \mathbf{r}. \quad (\text{i})$$

But $\frac{d\mathbf{R}}{dt} \mathbf{R}^T$ is an antisymmetric tensor (see the previous example, Example 2.26.2) so that

$$\frac{d\mathbf{r}}{dt} = \boldsymbol{\omega} \times \mathbf{r}, \quad (\text{ii})$$

where $\boldsymbol{\omega}$ is the dual vector of $\frac{d\mathbf{R}}{dt} \mathbf{R}^T$. From the well-known equation in rigid body kinematics, we can identify $\boldsymbol{\omega}$ as the angular velocity of the rigid body.

2.27 SCALAR FIELD AND GRADIENT OF A SCALAR FUNCTION

Let $\phi(\mathbf{r})$ be a scalar-valued function of the position vector \mathbf{r} . That is, for each position \mathbf{r} , $\phi(\mathbf{r})$ gives the value of a scalar, such as density, temperature, or electric potential at the point. In other words, $\phi(\mathbf{r})$ describes a scalar field. Associated with a scalar field is a vector field, called the *gradient* of ϕ . The gradient of ϕ at a point is defined to be a vector, denoted by $\text{grad } \phi$ or by $\nabla\phi$ such that its dot product with $d\mathbf{r}$ gives the difference of the values of the scalar at $\mathbf{r} + d\mathbf{r}$ and \mathbf{r} , i.e.,

$$d\phi = \phi(\mathbf{r} + d\mathbf{r}) - \phi(\mathbf{r}) = \nabla\phi \cdot d\mathbf{r}. \quad (2.27.1)$$

If dr denote the magnitude of $d\mathbf{r}$, and \mathbf{e} the unit vector in the direction of $d\mathbf{r}$ (Note: $\mathbf{e} = d\mathbf{r}/dr$). Then the above equation gives, for $d\mathbf{r}$ in the \mathbf{e} direction,

$$\frac{d\phi}{dr} = \nabla\phi \cdot \mathbf{e}. \quad (2.27.2)$$

That is, the component of $\nabla\phi$ in the direction of \mathbf{e} gives the rate of change of ϕ in that direction (directional derivative). In particular, the components of $\nabla\phi$ in the coordinate directions \mathbf{e}_i are given by

$$\frac{\partial\phi}{\partial x_i} = \left(\frac{d\phi}{dr} \right)_{\mathbf{e}_i - d\mathbf{r}} = \nabla\phi \cdot \mathbf{e}_i. \quad (2.27.3)$$

Therefore, the Cartesian components of $\nabla\phi$ are $\partial\phi/\partial x_i$, that is,

$$\nabla\phi = \frac{\partial\phi}{\partial x_1} \mathbf{e}_1 + \frac{\partial\phi}{\partial x_2} \mathbf{e}_2 + \frac{\partial\phi}{\partial x_3} \mathbf{e}_3 = \frac{\partial\phi}{\partial x_i} \mathbf{e}_i. \quad (2.27.4)$$

The gradient vector has a simple geometrical interpretation. For example, if $\phi(\mathbf{r})$ describes a temperature field, then, on a surface of constant temperature (i.e., isothermal surface), $\phi = \text{constant}$. Let \mathbf{r} be a point on an isothermal surface. Then, for any and all neighboring point $\mathbf{r} + d\mathbf{r}$ on the same isothermal surface, $d\phi = 0$. Thus, $\nabla\phi \cdot d\mathbf{r} = 0$. In other words, $\nabla\phi$ is a vector, perpendicular to the surface at the point \mathbf{r} . On the other hand, the dot product $\nabla\phi \cdot d\mathbf{r}$ is a maximum when $d\mathbf{r}$ is in the same direction as $\nabla\phi$. In other words, $\nabla\phi$ is greatest if $d\mathbf{r}$ is normal to the surface of constant ϕ and in this case, $d\phi = |\nabla\phi|dr$, or

$$\left(\frac{d\phi}{dr} \right)_{\max} = |\nabla\phi|, \quad (2.27.5)$$

for $d\mathbf{r}$ in the direction normal to the surface of constant temperature.

Example 2.27.1

If $\phi = x_1x_2 + 2x_3$, find a unit vector \mathbf{n} normal to the surface of a constant ϕ passing through the point $(2,1,0)$.

Solution

By Eq. (2.27.4),

$$\nabla\phi = \frac{\partial\phi}{\partial x_1}\mathbf{e}_1 + \frac{\partial\phi}{\partial x_2}\mathbf{e}_2 + \frac{\partial\phi}{\partial x_3}\mathbf{e}_3 = x_2\mathbf{e}_1 + x_1\mathbf{e}_2 + 2\mathbf{e}_3.$$

At the point $(2,1,0)$, $\nabla\phi = \mathbf{e}_1 + 2\mathbf{e}_2 + 2\mathbf{e}_3$. Thus,

$$\mathbf{n} = \frac{1}{3}(\mathbf{e}_1 + 2\mathbf{e}_2 + 2\mathbf{e}_3).$$

Example 2.27.2

If \mathbf{q} denotes the heat flux vector (rate of heat transfer/area), the Fourier heat conduction law states that

$$\mathbf{q} = -k\nabla\Theta, \quad (\text{i})$$

where Θ is the temperature field and k is thermal conductivity. If $\Theta = 2(x_1^2 + x_2^2)$, find $\nabla\Theta$ at the location $A(1,0)$ and $B(1/\sqrt{2}, 1/\sqrt{2})$. Sketch curves of constant Θ (isotherms) and indicate the vectors \mathbf{q} at the two points.

Solution

By Eq. (2.27.4),

$$\nabla\Theta = \frac{\partial\Theta}{\partial x_1}\mathbf{e}_1 + \frac{\partial\Theta}{\partial x_2}\mathbf{e}_2 + \frac{\partial\Theta}{\partial x_3}\mathbf{e}_3 = 4x_1\mathbf{e}_1 + 4x_2\mathbf{e}_2.$$

Thus,

$$\mathbf{q} = -4k(x_1\mathbf{e}_1 + x_2\mathbf{e}_2).$$

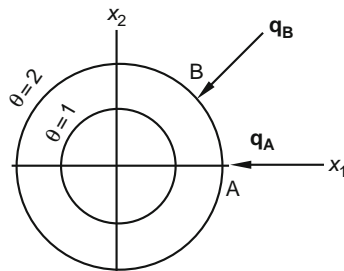

FIGURE 2.27-1

At point A ,

$$\mathbf{q}_A = -4k\mathbf{e}_1,$$

and at point B ,

$$\mathbf{q}_B = -2\sqrt{2}k(\mathbf{e}_1 + \mathbf{e}_2).$$

Clearly, the isotherms, Figure 2.27-1, are circles and the heat flux is an inward radial vector (consistent with heat flowing from higher to lower temperatures).

Example 2.27.3

A more general heat conduction law can be given in the following form:

$$\mathbf{q} = -\mathbf{K}\nabla\Theta,$$

where \mathbf{K} is a tensor known as thermal conductivity tensor. (a) What tensor \mathbf{K} corresponds to the Fourier heat conduction law mentioned in the previous example? (b) Find \mathbf{q} if $\Theta = 2x_1 + 3x_2$, and

$$[\mathbf{K}] = \begin{bmatrix} 2 & -1 & 0 \\ -1 & 2 & 0 \\ 0 & 0 & 3 \end{bmatrix}.$$

Solution

(a) Clearly, $\mathbf{K} = k\mathbf{I}$, so that $\mathbf{q} = -k\mathbf{I}\nabla\Theta = -k\nabla\Theta$.

(b) $\nabla\Theta = 2\mathbf{e}_1 + 3\mathbf{e}_2$ and

$$[\mathbf{q}] = - \begin{bmatrix} 2 & -1 & 0 \\ -1 & 2 & 0 \\ 0 & 0 & 3 \end{bmatrix} \begin{bmatrix} 2 \\ 3 \\ 0 \end{bmatrix} = \begin{bmatrix} -1 \\ -4 \\ 0 \end{bmatrix}$$

that is,

$$\mathbf{q} = -\mathbf{e}_1 - 4\mathbf{e}_2,$$

which is clearly not normal to the isotherm (see Figure 2.27-2).

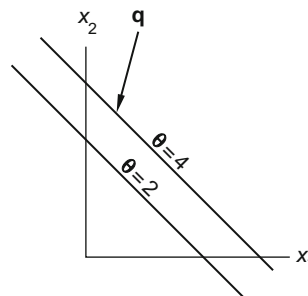

FIGURE 2.27-2

2.28 VECTOR FIELD AND GRADIENT OF A VECTOR FUNCTION

Let $\mathbf{v}(\mathbf{r})$ be a vector-valued function of position describing, for example, a displacement or a velocity field. Associated with $\mathbf{v}(\mathbf{r})$, is a tensor field, called the *gradient* of \mathbf{v} , which is of considerable importance. The gradient of \mathbf{v} (denoted by $\nabla\mathbf{v}$ or $\text{grad } \mathbf{v}$) is defined to be the second-order tensor, which, when operating on $d\mathbf{r}$, gives the difference of \mathbf{v} at $\mathbf{r} + d\mathbf{r}$ and \mathbf{r} . That is,

$$d\mathbf{v} = \mathbf{v}(\mathbf{r} + d\mathbf{r}) - \mathbf{v}(\mathbf{r}) = (\nabla\mathbf{v})d\mathbf{r}. \quad (2.28.1)$$

Again, let dr denote $|d\mathbf{r}|$ and \mathbf{e} denote $d\mathbf{r}/dr$; we have

$$\left(\frac{d\mathbf{v}}{dr}\right)_{\text{in } \mathbf{e}\text{-direction}} = (\nabla\mathbf{v})\mathbf{e}. \quad (2.28.2)$$

Therefore, the second-order tensor $\nabla\mathbf{v}$ transforms a unit vector \mathbf{e} into the vector describing the rate of change of \mathbf{v} in that direction. In Cartesian coordinates,

$$\left(\frac{d\mathbf{v}}{dr}\right)_{\text{in } \mathbf{e}_j\text{-direction}} = \frac{\partial\mathbf{v}}{\partial x_j} = (\nabla\mathbf{v})\mathbf{e}_j, \quad (2.28.3)$$

therefore, the components of $\nabla\mathbf{v}$ in indicial notation are given by

$$(\nabla\mathbf{v})_{ij} = \mathbf{e}_i \cdot (\nabla\mathbf{v})\mathbf{e}_j = \mathbf{e}_i \cdot \frac{\partial\mathbf{v}}{\partial x_j} = \frac{\partial(\mathbf{v} \cdot \mathbf{e}_i)}{\partial x_j} = \frac{\partial v_i}{\partial x_j}, \quad (2.28.4)$$

and in matrix form

$$[\nabla\mathbf{v}] = \begin{bmatrix} \frac{\partial v_1}{\partial x_1} & \frac{\partial v_1}{\partial x_2} & \frac{\partial v_1}{\partial x_3} \\ \frac{\partial v_2}{\partial x_1} & \frac{\partial v_2}{\partial x_2} & \frac{\partial v_2}{\partial x_3} \\ \frac{\partial v_3}{\partial x_1} & \frac{\partial v_3}{\partial x_2} & \frac{\partial v_3}{\partial x_3} \end{bmatrix}. \quad (2.28.5)$$

Geometrical interpretation of $\nabla\mathbf{v}$ will be given later in connection with the deformation of a continuum (Chapter 3).

2.29 DIVERGENCE OF A VECTOR FIELD AND DIVERGENCE OF A TENSOR FIELD

Let $\mathbf{v}(\mathbf{r})$ be a vector field. The *divergence* of $\mathbf{v}(\mathbf{r})$ is defined to be a scalar field given by the trace of the gradient of \mathbf{v} . That is,

$$\text{div } \mathbf{v} \equiv \text{tr}(\nabla\mathbf{v}). \quad (2.29.1)$$

In Cartesian coordinates, this gives

$$\text{div } \mathbf{v} = \frac{\partial v_1}{\partial x_1} + \frac{\partial v_2}{\partial x_2} + \frac{\partial v_3}{\partial x_3} = \frac{\partial v_i}{\partial x_i}. \quad (2.29.2)$$

Let $\mathbf{T}(\mathbf{r})$ be a tensor field. The divergence of $\mathbf{T}(\mathbf{r})$ is defined to be a vector field, denoted by $\text{div } \mathbf{T}$, such that for any vector \mathbf{a}

$$(\text{div } \mathbf{T}) \cdot \mathbf{a} \equiv \text{div}(\mathbf{T}^T \mathbf{a}) - \text{tr}(\mathbf{T}^T \nabla \mathbf{a}). \quad (2.29.3)$$

To find the Cartesian components of the vector $\text{div } \mathbf{T}$, let $\mathbf{b} = \text{div } \mathbf{T}$, then (*Note:* $\nabla \mathbf{e}_i = \mathbf{0}$ for Cartesian coordinates), from (2.29.3), we have

$$b_i = \mathbf{b} \cdot \mathbf{e}_i = \text{div}(\mathbf{T}^T \mathbf{e}_i) - \text{tr}(\mathbf{T}^T \nabla \mathbf{e}_i) = \text{div}(T_{ij} \mathbf{e}_j) - 0 = \partial T_{ij} / \partial x_j. \quad (2.29.4)$$

In other words,

$$\text{div } \mathbf{T} = (\partial T_{ij} / \partial x_j) \mathbf{e}_i. \quad (2.29.5)^*$$

Example 2.29.1

Let $\alpha = \alpha(\mathbf{r})$ and $\mathbf{a} = \mathbf{a}(\mathbf{r})$. Show that $\text{div}(\alpha \mathbf{a}) = \alpha \text{div } \mathbf{a} + (\nabla \alpha) \cdot \mathbf{a}$.

Solution

Let $\mathbf{b} = \alpha \mathbf{a}$. Then $b_i = \alpha a_i$, so

$$\text{div } \mathbf{b} = \frac{\partial b_i}{\partial x_i} = \alpha \frac{\partial a_i}{\partial x_i} + \frac{\partial \alpha}{\partial x_i} a_i.$$

That is,

$$\text{div}(\alpha \mathbf{a}) = \alpha \text{div } \mathbf{a} + (\nabla \alpha) \cdot \mathbf{a}. \quad (2.29.6)$$

Example 2.29.2

Given $\alpha = \alpha(\mathbf{r})$ and $\mathbf{T} = \mathbf{T}(\mathbf{r})$, show that

$$\text{div}(\alpha \mathbf{T}) = \mathbf{T}(\nabla \alpha) + \alpha \text{div } \mathbf{T}. \quad (2.29.7)$$

Solution

We have, from (2.29.5),

$$\text{div}(\alpha \mathbf{T}) = \frac{\partial(\alpha T_{ij})}{\partial x_j} \mathbf{e}_i = \frac{\partial \alpha}{\partial x_j} T_{ij} \mathbf{e}_i + \alpha \frac{\partial T_{ij}}{\partial x_j} \mathbf{e}_i = \mathbf{T}(\nabla \alpha) + \alpha \text{div } \mathbf{T}.$$

*We note that the Cartesian components of the third-order tensor $\mathbf{M} \equiv \nabla \mathbf{T} = \nabla(T_{ij} \mathbf{e}_j \mathbf{e}_i)$ are $\partial T_{ij} / \partial x_k$. In terms of $\mathbf{M} = M_{ijk} \mathbf{e}_j \mathbf{e}_i \mathbf{e}_k$, $\text{div } \mathbf{T}$ is a vector given by $M_{ijj} \mathbf{e}_i$. More on the components of $\nabla \mathbf{T}$ will be given in Chapter 8.

2.30 CURL OF A VECTOR FIELD

Let $\mathbf{v}(\mathbf{r})$ be a vector field. The *curl* of $\mathbf{v}(\mathbf{r})$ is defined to be a vector field given by twice the dual vector of the antisymmetric part of $\nabla\mathbf{v}$. That is

$$\text{curl } \mathbf{v} \equiv 2\mathbf{t}^{\mathbf{A}}, \quad (2.30.1)$$

where $\mathbf{t}^{\mathbf{A}}$ is the dual vector of $(\nabla\mathbf{v})^{\mathbf{A}}$.

In rectangular Cartesian coordinates,

$$[\nabla\mathbf{v}]^{\mathbf{A}} = \begin{bmatrix} 0 & \frac{1}{2} \left(\frac{\partial v_1}{\partial x_2} - \frac{\partial v_2}{\partial x_1} \right) & \frac{1}{2} \left(\frac{\partial v_1}{\partial x_3} - \frac{\partial v_3}{\partial x_1} \right) \\ -\frac{1}{2} \left(\frac{\partial v_1}{\partial x_2} - \frac{\partial v_2}{\partial x_1} \right) & 0 & \frac{1}{2} \left(\frac{\partial v_2}{\partial x_3} - \frac{\partial v_3}{\partial x_2} \right) \\ -\frac{1}{2} \left(\frac{\partial v_1}{\partial x_3} - \frac{\partial v_3}{\partial x_1} \right) & -\frac{1}{2} \left(\frac{\partial v_2}{\partial x_3} - \frac{\partial v_3}{\partial x_2} \right) & 0 \end{bmatrix}. \quad (2.30.2)$$

Thus, the curl of $\mathbf{v}(\mathbf{r})$ is given by [see Eq. (2.21.3)]:

$$\text{curl } \mathbf{v} = 2\mathbf{t}^{\mathbf{A}} = \left(\frac{\partial v_3}{\partial x_2} - \frac{\partial v_2}{\partial x_3} \right) \mathbf{e}_1 + \left(\frac{\partial v_1}{\partial x_3} - \frac{\partial v_3}{\partial x_1} \right) \mathbf{e}_2 + \left(\frac{\partial v_2}{\partial x_1} - \frac{\partial v_1}{\partial x_2} \right) \mathbf{e}_3. \quad (2.30.3)$$

It can be easily verified that in indicial notation

$$\text{curl } \mathbf{v} = -\varepsilon_{ijk} \frac{\partial v_j}{\partial x_k} \mathbf{e}_i. \quad (2.30.4)$$

2.31 LAPLACIAN OF A SCALAR FIELD

Let $f(\mathbf{r})$ be a scalar-valued function of the position vector \mathbf{r} . The definition of the Laplacian of a scalar field is given by

$$\nabla^2 f = \text{div} (\nabla f) = \text{tr}(\nabla(\nabla f)). \quad (2.31.1)$$

In rectangular coordinates the Laplacian becomes

$$\nabla^2 f = \text{tr}(\nabla(\nabla f)) = \frac{\partial^2 f}{\partial x_i \partial x_i} = \frac{\partial^2 f}{\partial x_1^2} + \frac{\partial^2 f}{\partial x_2^2} + \frac{\partial^2 f}{\partial x_3^2}. \quad (2.31.2)$$

2.32 LAPLACIAN OF A VECTOR FIELD

Let $\mathbf{v}(\mathbf{r})$ be a vector field. The Laplacian of \mathbf{v} is defined by the following:

$$\nabla^2 \mathbf{v} = \nabla (\text{div } \mathbf{v}) - \text{curl} (\text{curl } \mathbf{v}). \quad (2.32.1)$$

In rectangular coordinates,

$$\nabla(\operatorname{div} \mathbf{v}) = \frac{\partial}{\partial x_i} \left(\frac{\partial v_k}{\partial x_k} \right) \mathbf{e}_i, \quad \operatorname{curl} \mathbf{v} = -\varepsilon_{zjk} \left(\frac{\partial v_j}{\partial x_k} \right) \mathbf{e}_z, \quad (2.32.2)$$

and

$$\operatorname{curl}(\operatorname{curl} \mathbf{v}) = -\varepsilon_{iz\beta} \frac{\partial}{\partial x_\beta} \left(-\varepsilon_{zjk} \frac{\partial v_j}{\partial x_k} \right) \mathbf{e}_i = \varepsilon_{iz\beta} \varepsilon_{zjk} \frac{\partial}{\partial x_\beta} \left(\frac{\partial v_j}{\partial x_k} \right) \mathbf{e}_i. \quad (2.32.3)$$

Now $\varepsilon_{iz\beta} \varepsilon_{zjk} = -\varepsilon_{zi\beta} \varepsilon_{zjk} = -(\delta_{ij} \delta_{\beta k} - \delta_{ik} \delta_{\beta j})$ [see Prob. 2.12], therefore,

$$\operatorname{curl}(\operatorname{curl} \mathbf{v}) = -(\delta_{ij} \delta_{\beta k} - \delta_{ik} \delta_{\beta j}) \frac{\partial}{\partial x_\beta} \left(\frac{\partial v_j}{\partial x_k} \right) \mathbf{e}_i = \left\{ -\frac{\partial}{\partial x_\beta} \left(\frac{\partial v_i}{\partial x_\beta} \right) + \frac{\partial}{\partial x_\beta} \left(\frac{\partial v_\beta}{\partial x_i} \right) \right\} \mathbf{e}_i. \quad (2.32.4)$$

Thus,

$$\nabla^2 \mathbf{v} = \nabla(\operatorname{div} \mathbf{v}) - \operatorname{curl}(\operatorname{curl} \mathbf{v}) = \frac{\partial}{\partial x_i} \left(\frac{\partial v_k}{\partial x_k} \right) \mathbf{e}_i - \left\{ -\frac{\partial}{\partial x_\beta} \left(\frac{\partial v_i}{\partial x_\beta} \right) + \frac{\partial}{\partial x_i} \left(\frac{\partial v_\beta}{\partial x_\beta} \right) \right\} \mathbf{e}_i. \quad (2.32.5)$$

That is, in rectangular coordinates,

$$\nabla^2 \mathbf{v} = \frac{\partial^2 v_i}{\partial x_\beta \partial x_\beta} \mathbf{e}_i = \nabla^2 v_i \mathbf{e}_i. \quad (2.32.6)$$

In long form,

$$\nabla^2 \mathbf{v} = \left(\frac{\partial^2 v_1}{\partial x_1^2} + \frac{\partial^2 v_1}{\partial x_2^2} + \frac{\partial^2 v_1}{\partial x_3^2} \right) \mathbf{e}_1 + \left(\frac{\partial^2 v_2}{\partial x_1^2} + \frac{\partial^2 v_2}{\partial x_2^2} + \frac{\partial^2 v_2}{\partial x_3^2} \right) \mathbf{e}_2 + \left(\frac{\partial^2 v_3}{\partial x_1^2} + \frac{\partial^2 v_3}{\partial x_2^2} + \frac{\partial^2 v_3}{\partial x_3^2} \right) \mathbf{e}_3. \quad (2.32.7)$$

Expressions for the polar, cylindrical, and spherical coordinate systems are given in Part D.

PROBLEMS FOR PART C

2.62 Prove the identity $\frac{d}{dt}(\mathbf{T} + \mathbf{S}) = \frac{d\mathbf{T}}{dt} + \frac{d\mathbf{S}}{dt}$ using the definition of derivative of a tensor.

2.63 Prove the identity $\frac{d}{dt}(\mathbf{T}\mathbf{S}) = \mathbf{T} \frac{d\mathbf{S}}{dt} + \frac{d\mathbf{T}}{dt} \mathbf{S}$ using the definition of derivative of a tensor.

2.64 Prove that $\frac{d\mathbf{T}^T}{dt} = \left(\frac{d\mathbf{T}}{dt} \right)^T$ by differentiating the definition $\mathbf{a} \cdot \mathbf{T}\mathbf{b} = \mathbf{b} \cdot \mathbf{T}^T \mathbf{a}$, where \mathbf{a} and \mathbf{b} are arbitrary constant vectors.

2.65 Consider the scalar field $\phi = x_1^2 + 3x_1x_2 + 2x_3$. (a) Find the unit vector normal to the surface of constant ϕ at the origin and at (1,0,1). (b) What is the maximum value of the directional derivative of ϕ at the origin? at (1,0,1)? (c) Evaluate $d\phi/dr$ at the origin if $d\mathbf{r} = ds(\mathbf{e}_1 + \mathbf{e}_3)$.

2.66 Consider the ellipsoidal surface defined by the equation $x^2/a^2 + y^2/b^2 + z^2/b^2 = 1$. Find the unit vector normal to the surface at a given point (x, y, z) .

- 2.67 Consider the temperature field given by $\Theta = 3x_1x_2$. (a) If $\mathbf{q} = -k\nabla\Theta$, find the heat flux at the point $A(1,1,1)$. (b) If $\mathbf{q} = -\mathbf{K}\nabla\Theta$, find the heat flux at the same point, where

$$[\mathbf{K}] = \begin{bmatrix} k & 0 & 0 \\ 0 & 2k & 0 \\ 0 & 0 & 3k \end{bmatrix}.$$

- 2.68 Let $\phi(x_1, x_2, x_3)$ and $\psi(x_1, x_2, x_3)$ be scalar fields, and let $\mathbf{v}(x_1, x_2, x_3)$ and $\mathbf{w}(x_1, x_2, x_3)$ be vector fields. By writing the subscripted components form, verify the following identities:

- (a) $\nabla(\phi + \psi) = \nabla\phi + \nabla\psi$, sample solution:

$$[\nabla(\phi + \psi)]_i = \frac{\partial(\phi + \psi)}{\partial x_i} = \frac{\partial\phi}{\partial x_i} + \frac{\partial\psi}{\partial x_i} = \nabla\phi + \nabla\psi,$$

- (b) $\text{div}(\mathbf{v} + \mathbf{w}) = \text{div } \mathbf{v} + \text{div } \mathbf{w}$, (c) $\text{div}(\phi\mathbf{v}) = (\nabla\phi)\mathbf{v} + \phi(\text{div } \mathbf{v})$ and (d) $\text{div}(\text{curl } \mathbf{v}) = 0$.

- 2.69 Consider the vector field $\mathbf{v} = x_1^2\mathbf{e}_1 + x_2^2\mathbf{e}_2 + x_3^2\mathbf{e}_3$. For the point $(1,1,0)$, find (a) $\nabla\mathbf{v}$, (b) $(\nabla\mathbf{v})\mathbf{v}$, (c) $\text{div } \mathbf{v}$ and $\text{curl } \mathbf{v}$, and (d) the differential $d\mathbf{v}$ for $d\mathbf{r} = ds(\mathbf{e}_1 + \mathbf{e}_2 + \mathbf{e}_3)/\sqrt{3}$.

PART D: CURVILINEAR COORDINATES

In Part C, the Cartesian components for various vector and tensor operations such as the gradient, the divergence, and the Laplacian of a scalar field and tensor fields were derived. In this part, components in polar, cylindrical, and spherical coordinates for these same operations will be derived.

2.33 POLAR COORDINATES

Consider polar coordinates (r, θ) , (see Figure 2.33-1) such that

$$r = \sqrt{x_1^2 + x_2^2} \quad \text{and} \quad \theta = \tan^{-1} \frac{x_2}{x_1}. \quad (2.33.1)$$

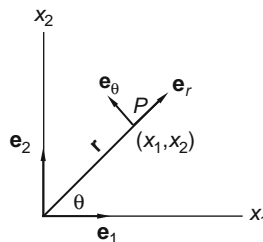

FIGURE 2.33-1

The unit base vectors \mathbf{e}_r and \mathbf{e}_θ can be expressed in terms of the Cartesian base vectors \mathbf{e}_1 and \mathbf{e}_2 as

$$\mathbf{e}_r = \cos\theta\mathbf{e}_1 + \sin\theta\mathbf{e}_2, \quad \mathbf{e}_\theta = -\sin\theta\mathbf{e}_1 + \cos\theta\mathbf{e}_2. \quad (2.33.2)$$

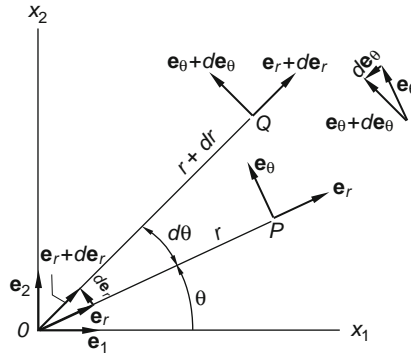

FIGURE 2.33-2

These unit base vectors vary in direction as θ changes. In fact, from Eqs. (2.33.2), we have

$$d\mathbf{e}_r = (-\sin\theta\mathbf{e}_1 + \cos\theta\mathbf{e}_2)d\theta = d\theta\mathbf{e}_\theta, \quad d\mathbf{e}_\theta = (-\cos\theta\mathbf{e}_1 - \sin\theta\mathbf{e}_2)d\theta = -d\theta\mathbf{e}_r. \quad (2.33.3)$$

The geometrical representation of $d\mathbf{e}_r$ and $d\mathbf{e}_\theta$ are shown in Figure 2.33-2, where one notes that $\mathbf{e}_r(P)$ has rotated an infinitesimal angle $d\theta$ to become $\mathbf{e}_r(Q) = \mathbf{e}_r(P) + d\mathbf{e}_r$, where $d\mathbf{e}_r$ is perpendicular to $\mathbf{e}_r(P)$ with a magnitude $|d\mathbf{e}_r| = (1)d\theta = d\theta$. Similarly, $d\mathbf{e}_\theta$ is perpendicular to $\mathbf{e}_\theta(P)$ but pointing in the negative \mathbf{e}_r direction, and its magnitude is also $d\theta$.

Now, from the position vector

$$\mathbf{r} = r\mathbf{e}_r, \quad (2.33.4)$$

we have

$$d\mathbf{r} = d\mathbf{r}_e + r d\mathbf{e}_r. \quad (2.33.5)$$

Using Eq. (2.33.3), we get

$$d\mathbf{r} = d\mathbf{r}_e + rd\theta\mathbf{e}_\theta. \quad (2.33.6)$$

The geometrical representation of this equation is also easily seen if one notes that $d\mathbf{r}$ is the vector PQ in the preceding figure.

The components of ∇f , $\nabla \mathbf{v}$, $\text{div } \mathbf{v}$, $\text{div } \mathbf{T}$, $\nabla^2 f$ and $\nabla^2 \mathbf{v}$ in polar coordinates will now be obtained.

(i) Components of ∇f :

Let $f(r, \theta)$ be a scalar field. By definition of the gradient of f , we have

$$df = \nabla f \cdot d\mathbf{r} = (a_r\mathbf{e}_r + a_\theta\mathbf{e}_\theta) \cdot (d\mathbf{r}_e + rd\theta\mathbf{e}_\theta) = a_r dr + a_\theta r d\theta, \quad (2.33.7)$$

where a_r and a_θ are components of ∇f in the \mathbf{e}_r and \mathbf{e}_θ direction, respectively. But from calculus,

$$df = \frac{\partial f}{\partial r} dr + \frac{\partial f}{\partial \theta} d\theta. \quad (2.33.8)$$

Since Eqs. (2.33.7) and (2.33.8) must yield the same result for all increments $dr, d\theta$, we have

$$a_r = \frac{\partial f}{\partial r}, \quad a_\theta = \frac{1}{r} \frac{\partial f}{\partial \theta}, \quad (2.33.9)$$

thus,

$$\nabla f = \frac{\partial f}{\partial r} \mathbf{e}_r + \frac{1}{r} \frac{\partial f}{\partial \theta} \mathbf{e}_\theta. \quad (2.33.10)$$

(ii) Components of $\nabla \mathbf{v}$: Let

$$\mathbf{v}(r, \theta) = v_r(r, \theta) \mathbf{e}_r + v_\theta(r, \theta) \mathbf{e}_\theta. \quad (2.33.11)$$

By definition of $\nabla \mathbf{v}$, we have

$$d\mathbf{v} = \nabla \mathbf{v} d\mathbf{r}. \quad (2.33.12)$$

Let $\mathbf{T} = \nabla \mathbf{v}$. Then

$$d\mathbf{v} = \mathbf{T} d\mathbf{r} = \mathbf{T}(dr \mathbf{e}_r + rd\theta \mathbf{e}_\theta) = dr \mathbf{T} \mathbf{e}_r + rd\theta \mathbf{T} \mathbf{e}_\theta. \quad (2.33.13)$$

Now

$$\mathbf{T} \mathbf{e}_r = T_{rr} \mathbf{e}_r + T_{\theta r} \mathbf{e}_\theta \quad \text{and} \quad \mathbf{T} \mathbf{e}_\theta = T_{r\theta} \mathbf{e}_r + T_{\theta\theta} \mathbf{e}_\theta, \quad (2.33.14)$$

therefore,

$$d\mathbf{v} = (T_{rr} dr + T_{r\theta} rd\theta) \mathbf{e}_r + (T_{\theta r} dr + T_{\theta\theta} rd\theta) \mathbf{e}_\theta. \quad (2.33.15)$$

From Eq. (2.33.11), we also have

$$d\mathbf{v} = dv_r \mathbf{e}_r + v_r d\mathbf{e}_r + dv_\theta \mathbf{e}_\theta + v_\theta d\mathbf{e}_\theta. \quad (2.33.16)$$

Since [see Eq. (2.33.3)]

$$d\mathbf{e}_r = d\theta \mathbf{e}_\theta, \quad d\mathbf{e}_\theta = -d\theta \mathbf{e}_r, \quad (2.33.17)$$

therefore, Eq. (2.33.16) becomes

$$d\mathbf{v} = (dv_r - v_\theta d\theta) \mathbf{e}_r + (v_r d\theta + dv_\theta) \mathbf{e}_\theta. \quad (2.33.18)$$

From calculus,

$$dv_r = \frac{\partial v_r}{\partial r} dr + \frac{\partial v_r}{\partial \theta} d\theta, \quad dv_\theta = \frac{\partial v_\theta}{\partial r} dr + \frac{\partial v_\theta}{\partial \theta} d\theta. \quad (2.33.19)$$

Substituting Eq. (2.33.19) into Eq. (2.33.18), we have

$$d\mathbf{v} = \left[\frac{\partial v_r}{\partial r} dr + \left(\frac{\partial v_r}{\partial \theta} - v_\theta \right) d\theta \right] \mathbf{e}_r + \left[\frac{\partial v_\theta}{\partial r} dr + \left(\frac{\partial v_\theta}{\partial \theta} + v_r \right) d\theta \right] \mathbf{e}_\theta. \quad (2.33.20)$$

Eq. (2.33.15) and Eq. (2.33.20), then, give

$$\frac{\partial v_r}{\partial r} dr + \left(\frac{\partial v_r}{\partial \theta} - v_\theta \right) d\theta = T_{rr} dr + T_{r\theta} rd\theta, \quad \frac{\partial v_\theta}{\partial r} dr + \left(\frac{\partial v_\theta}{\partial \theta} + v_r \right) d\theta = T_{\theta r} dr + T_{\theta\theta} rd\theta. \quad (2.33.21)$$

Eq. (2.33.21) must hold for any values of dr and $d\theta$. Thus,

$$T_{rr} = \frac{\partial v_r}{\partial r}, \quad T_{r\theta} = \frac{1}{r} \left(\frac{\partial v_r}{\partial \theta} - v_\theta \right), \quad T_{\theta r} = \frac{\partial v_\theta}{\partial r}, \quad T_{\theta\theta} = \frac{1}{r} \left(\frac{\partial v_\theta}{\partial \theta} + v_r \right). \quad (2.33.22)$$

In matrix form,

$$[\nabla \mathbf{v}] = \begin{bmatrix} \frac{\partial v_r}{\partial r} & \frac{1}{r} \left(\frac{\partial v_r}{\partial \theta} - v_\theta \right) \\ \frac{\partial v_\theta}{\partial r} & \frac{1}{r} \left(\frac{\partial v_\theta}{\partial \theta} + v_r \right) \end{bmatrix}. \quad (2.33.23)$$

(iii) **div \mathbf{v} :**

Using the components of $\nabla \mathbf{v}$ given in (ii), that is, Eq. (2.33.23), we have

$$\operatorname{div} \mathbf{v} = \operatorname{tr}(\nabla \mathbf{v}) = \frac{\partial v_r}{\partial r} + \frac{1}{r} \left(\frac{\partial v_\theta}{\partial \theta} + v_r \right). \quad (2.33.24)$$

(iv) **Components of curl \mathbf{v} :**

The antisymmetric part of $\nabla \mathbf{v}$ is

$$[\nabla \mathbf{v}]^A = \frac{1}{2} \begin{bmatrix} 0 & \frac{1}{r} \left(\frac{\partial v_r}{\partial \theta} - v_\theta \right) - \frac{\partial v_\theta}{\partial r} \\ - \left\{ \frac{1}{r} \left(\frac{\partial v_r}{\partial \theta} - v_\theta \right) - \frac{\partial v_\theta}{\partial r} \right\} & 0 \end{bmatrix}. \quad (2.33.25)$$

Therefore, from the definition that $\operatorname{curl} \mathbf{v} =$ twice the dual vector of $(\nabla \mathbf{v})^A$, we have

$$\operatorname{curl} \mathbf{v} = \left(\frac{\partial v_\theta}{\partial r} + \frac{v_\theta}{r} - \frac{1}{r} \frac{\partial v_r}{\partial \theta} \right) \mathbf{e}_3. \quad (2.33.26)$$

(v) **Components of div \mathbf{T} :**

The invariant definition of the divergence of a second-order tensor is

$$(\operatorname{div} \mathbf{T}) \cdot \mathbf{a} = \operatorname{div}(\mathbf{T}^T \mathbf{a}) - \operatorname{tr}((\nabla \mathbf{a}) \mathbf{T}^T) \text{ for any } \mathbf{a}. \quad (2.33.27)$$

Take $\mathbf{a} = \mathbf{e}_r$; then the preceding equation gives

$$(\operatorname{div} \mathbf{T})_r = \operatorname{div}(\mathbf{T}^T \mathbf{e}_r) - \operatorname{tr}((\nabla \mathbf{e}_r) \mathbf{T}^T). \quad (2.33.28)$$

To evaluate the first term on the right-hand side, we note that

$$\mathbf{T}^T \mathbf{e}_r = T_{rr} \mathbf{e}_r + T_{r\theta} \mathbf{e}_\theta, \quad (2.33.29)$$

so that according to Eq. (2.33.24),

$$\operatorname{div}(\mathbf{T}^T \mathbf{e}_r) = \operatorname{div}(T_{rr} \mathbf{e}_r + T_{r\theta} \mathbf{e}_\theta) = \frac{\partial T_{rr}}{\partial r} + \frac{1}{r} \left(\frac{\partial T_{r\theta}}{\partial \theta} + T_{rr} \right). \quad (2.33.30)$$

To evaluate the second term, we first use Eq. (2.33.23) to obtain $\nabla \mathbf{e}_r$. In fact, since $\mathbf{e}_r = (1)\mathbf{e}_r + (0)\mathbf{e}_\theta$, we have, with $v_r = 1$ and $v_\theta = 0$,

$$[\nabla \mathbf{e}_r] = \begin{bmatrix} 0 & 0 \\ 0 & \frac{1}{r} \end{bmatrix}, \quad [\nabla \mathbf{e}_r][\mathbf{T}^T] = \begin{bmatrix} 0 & 0 \\ \frac{T_{r\theta}}{r} & \frac{T_{\theta\theta}}{r} \end{bmatrix}, \quad \text{tr}([\nabla \mathbf{e}_r][\mathbf{T}^T]) = \frac{T_{\theta\theta}}{r}. \quad (2.33.31)$$

Thus, Eq. (2.33.28) gives

$$(\text{div } \mathbf{T})_r = \frac{\partial T_{rr}}{\partial r} + \frac{1}{r} \frac{\partial T_{r\theta}}{\partial \theta} + \frac{T_{rr} - T_{\theta\theta}}{r}. \quad (2.33.32)$$

In a similar manner, one can derive

$$(\text{div } \mathbf{T})_\theta = \frac{\partial T_{\theta r}}{\partial r} + \frac{1}{r} \frac{\partial T_{\theta\theta}}{\partial \theta} + \frac{T_{r\theta} + T_{\theta r}}{r}. \quad (2.33.33)$$

(vi) Laplacian of $f(\mathbf{x})$:

Given a scalar field $f(\mathbf{x})$, the Laplacian of $f(\mathbf{x})$ is given by $\nabla^2 f = \text{div}(\nabla f) = \text{tr}(\nabla(\nabla f))$. In polar coordinates,

$$\nabla f = \frac{\partial f}{\partial r} \mathbf{e}_r + \frac{1}{r} \frac{\partial f}{\partial \theta} \mathbf{e}_\theta. \quad (2.33.34)$$

From, $\text{div } \mathbf{v} = \frac{\partial v_r}{\partial r} + \frac{1}{r} \frac{\partial v_\theta}{\partial \theta} + \frac{v_r}{r}$, we have

$$\nabla^2 f = \text{div } \nabla f = \frac{\partial^2 f}{\partial r^2} + \frac{1}{r^2} \frac{\partial^2 f}{\partial \theta^2} + \frac{1}{r} \frac{\partial f}{\partial r}. \quad (2.33.35)$$

(vii) Laplacian of a vector field $\mathbf{v}(\mathbf{x})$:

Laplacian of \mathbf{v} is given by: $\nabla^2 \mathbf{v} = \nabla(\text{div } \mathbf{v}) - \text{curl curl } \mathbf{v}$. Now, in polar coordinates:

$$\begin{aligned} \nabla(\text{div } \mathbf{v}) &= \frac{\partial}{\partial r} \left(\frac{\partial v_r}{\partial r} + \frac{1}{r} \frac{\partial v_\theta}{\partial \theta} + \frac{v_r}{r} \right) \mathbf{e}_r + \frac{1}{r} \frac{\partial}{\partial \theta} \left(\frac{\partial v_r}{\partial r} + \frac{1}{r} \frac{\partial v_\theta}{\partial \theta} + \frac{v_r}{r} \right) \mathbf{e}_\theta \\ &= \left(\frac{\partial^2 v_r}{\partial r^2} + \frac{1}{r} \frac{\partial^2 v_\theta}{\partial r \partial \theta} - \frac{1}{r^2} \frac{\partial v_\theta}{\partial \theta} + \frac{1}{r} \frac{\partial v_r}{\partial r} - \frac{v_r}{r^2} \right) \mathbf{e}_r + \left(\frac{1}{r} \frac{\partial^2 v_r}{\partial \theta \partial r} + \frac{1}{r^2} \frac{\partial^2 v_\theta}{\partial \theta^2} + \frac{1}{r^2} \frac{\partial v_r}{\partial \theta} \right) \mathbf{e}_\theta, \end{aligned} \quad (2.33.36)$$

and

$$\text{curl } \mathbf{v} = \left(\frac{\partial v_\theta}{\partial r} + \frac{v_\theta}{r} - \frac{1}{r} \frac{\partial v_r}{\partial \theta} \right) \mathbf{e}_z. \quad (2.33.37)$$

Since [see Eq. (2.34.7)]

$$\text{curl } \mathbf{v} = \left(\frac{1}{r} \frac{\partial v_z}{\partial \theta} - \frac{\partial v_\theta}{\partial z} \right) \mathbf{e}_r + \left(\frac{\partial v_r}{\partial z} - \frac{\partial v_z}{\partial r} \right) \mathbf{e}_\theta + \left(\frac{\partial v_\theta}{\partial r} + \frac{v_\theta}{r} - \frac{1}{r} \frac{\partial v_r}{\partial \theta} \right) \mathbf{e}_z,$$

therefore,

$$(\text{curl curl } \mathbf{v})_r = \frac{1}{r} \frac{\partial}{\partial \theta} \left(\frac{\partial v_\theta}{\partial r} + \frac{v_\theta}{r} - \frac{1}{r} \frac{\partial v_r}{\partial \theta} \right) = \left(\frac{1}{r} \frac{\partial^2 v_\theta}{\partial \theta \partial r} + \frac{1}{r^2} \frac{\partial v_\theta}{\partial \theta} - \frac{1}{r^2} \frac{\partial^2 v_r}{\partial \theta^2} \right), \quad (2.33.38)$$

$$(\text{curl curl } \mathbf{v})_\theta = -\frac{\partial}{\partial r} \left(\frac{\partial v_\theta}{\partial r} + \frac{v_\theta}{r} - \frac{1}{r} \frac{\partial v_r}{\partial \theta} \right) = \left(-\frac{\partial^2 v_\theta}{\partial r^2} - \frac{1}{r} \frac{\partial v_\theta}{\partial r} + \frac{v_\theta}{r^2} + \frac{1}{r} \frac{\partial^2 v_r}{\partial r \partial \theta} - \frac{1}{r^2} \frac{\partial v_r}{\partial \theta} \right). \quad (2.33.39)$$

Thus,

$$(\nabla^2 \mathbf{v})_r = \frac{\partial^2 v_r}{\partial r^2} + \frac{1}{r^2} \frac{\partial^2 v_r}{\partial \theta^2} + \frac{\partial^2 v_r}{\partial z^2} + \frac{1}{r} \frac{\partial v_r}{\partial r} - \frac{2}{r^2} \frac{\partial v_\theta}{\partial \theta} - \frac{v_r}{r^2}, \quad (2.33.40)$$

and

$$(\nabla^2 \mathbf{v})_\theta = \frac{\partial^2 v_\theta}{\partial r^2} + \frac{1}{r^2} \frac{\partial^2 v_\theta}{\partial \theta^2} + \frac{1}{r} \frac{\partial v_\theta}{\partial r} + \frac{2}{r^2} \frac{\partial v_r}{\partial \theta} - \frac{v_\theta}{r^2}. \quad (2.33.41)$$

2.34 CYLINDRICAL COORDINATES

In cylindrical coordinates, the position of a point P is determined by (r, θ, z) , where r and θ determine the position of the vertical projection of the point P on the xy plane (the point P' in Figure 2.34-1) and the coordinate z determines the height of the point P from the xy plane. In other words, the cylindrical coordinates is a polar coordinate (r, θ) in the xy plane plus a coordinate z perpendicular to the xy plane.

We shall denote the position vector of P by \mathbf{R} , rather than \mathbf{r} , to avoid confusion between the position vector \mathbf{R} and the coordinate r (which is a radial distance in the xy plane). The unit vector \mathbf{e}_r and \mathbf{e}_θ are on the xy plane and it is clear from Figure 2.34-1 that

$$\mathbf{R} = r\mathbf{e}_r + z\mathbf{e}_z, \quad (2.34.1)$$

and

$$d\mathbf{R} = dr\mathbf{e}_r + r d\mathbf{e}_r + dz\mathbf{e}_z + z d\mathbf{e}_z. \quad (2.34.2)$$

In the preceding equation, $d\mathbf{e}_r$ is given by exactly the same equation given earlier for the polar coordinates [Eq. (2.33.3)]. We note also that \mathbf{e}_z never changes its direction or magnitude regardless where the point P is, thus $d\mathbf{e}_z = 0$. Therefore,

$$d\mathbf{R} = dr\mathbf{e}_r + rd\theta\mathbf{e}_\theta + dz\mathbf{e}_z. \quad (2.34.3)$$

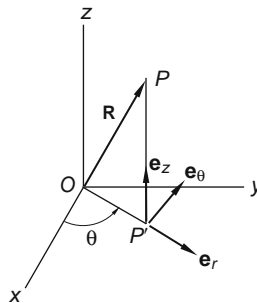

FIGURE 2.34-1

By retracing all the steps used in the previous section on polar coordinates, we can easily obtain the following results:

(i) Components of ∇f :

$$\nabla f = \frac{\partial f}{\partial r} \mathbf{e}_r + \frac{1}{r} \frac{\partial f}{\partial \theta} \mathbf{e}_\theta + \frac{\partial f}{\partial z} \mathbf{e}_z. \quad (2.34.4)$$

(ii) Components of $\nabla \mathbf{v}$:

$$[\nabla \mathbf{v}] = \begin{bmatrix} \frac{\partial v_r}{\partial r} & \frac{1}{r} \left(\frac{\partial v_r}{\partial \theta} - v_\theta \right) & \frac{\partial v_r}{\partial z} \\ \frac{\partial v_\theta}{\partial r} & \frac{1}{r} \left(\frac{\partial v_\theta}{\partial \theta} + v_r \right) & \frac{\partial v_\theta}{\partial z} \\ \frac{\partial v_z}{\partial r} & \frac{1}{r} \frac{\partial v_z}{\partial \theta} & \frac{\partial v_z}{\partial z} \end{bmatrix}. \quad (2.34.5)$$

(iii) $\operatorname{div} \mathbf{v}$:

$$\operatorname{div} \mathbf{v} = \frac{\partial v_r}{\partial r} + \frac{1}{r} \left(\frac{\partial v_\theta}{\partial \theta} + v_r \right) + \frac{\partial v_z}{\partial z}. \quad (2.34.6)$$

(iv) Components of $\operatorname{curl} \mathbf{v}$:

The vector $\operatorname{curl} \mathbf{v} =$ twice the dual vector of $(\nabla \mathbf{v})^A$, thus,

$$\operatorname{curl} \mathbf{v} = \left(\frac{1}{r} \frac{\partial v_z}{\partial \theta} - \frac{\partial v_\theta}{\partial z} \right) \mathbf{e}_r + \left(\frac{\partial v_r}{\partial z} - \frac{\partial v_z}{\partial r} \right) \mathbf{e}_\theta + \left(\frac{\partial v_\theta}{\partial r} + \frac{v_\theta}{r} - \frac{1}{r} \frac{\partial v_r}{\partial \theta} \right) \mathbf{e}_z. \quad (2.34.7)$$

(v) Components of $\operatorname{div} \mathbf{T}$:

$$(\operatorname{div} \mathbf{T})_r = \frac{\partial T_{rr}}{\partial r} + \frac{1}{r} \frac{\partial T_{r\theta}}{\partial \theta} + \frac{T_{rr} - T_{\theta\theta}}{r} + \frac{\partial T_{rz}}{\partial z}, \quad (2.34.8)$$

$$(\operatorname{div} \mathbf{T})_\theta = \frac{\partial T_{\theta r}}{\partial r} + \frac{1}{r} \frac{\partial T_{\theta\theta}}{\partial \theta} + \frac{T_{r\theta} + T_{\theta r}}{r} + \frac{\partial T_{\theta z}}{\partial z}, \quad (2.34.9)$$

$$(\operatorname{div} \mathbf{T})_z = \frac{\partial T_{zr}}{\partial r} + \frac{1}{r} \frac{\partial T_{z\theta}}{\partial \theta} + \frac{\partial T_{zz}}{\partial z} + \frac{T_{zr}}{r}. \quad (2.34.10)$$

(vi) Laplacian of f :

$$\nabla^2 f = \operatorname{div} \nabla f = \frac{\partial^2 f}{\partial r^2} + \frac{1}{r^2} \frac{\partial^2 f}{\partial \theta^2} + \frac{1}{r} \frac{\partial f}{\partial r} + \frac{\partial^2 f}{\partial z^2}. \quad (2.34.11)$$

(vii) Laplacian of \mathbf{v} :

$$(\nabla^2 \mathbf{v})_r = \frac{\partial^2 v_r}{\partial r^2} + \frac{1}{r^2} \frac{\partial^2 v_r}{\partial \theta^2} + \frac{\partial^2 v_r}{\partial z^2} + \frac{1}{r} \frac{\partial v_r}{\partial r} - \frac{v_r}{r^2} - \frac{2}{r^2} \frac{\partial v_\theta}{\partial \theta}, \quad (2.34.12)$$

$$(\nabla^2 \mathbf{v})_\theta = \frac{\partial^2 v_\theta}{\partial r^2} + \frac{1}{r^2} \frac{\partial^2 v_\theta}{\partial \theta^2} + \frac{\partial^2 v_\theta}{\partial z^2} + \frac{1}{r} \frac{\partial v_\theta}{\partial r} + \frac{2}{r^2} \frac{\partial v_r}{\partial \theta} - \frac{v_\theta}{r^2}, \quad (2.34.13)$$

$$(\nabla^2 \mathbf{v})_z = \frac{\partial^2 v_z}{\partial r^2} + \frac{1}{r^2} \frac{\partial^2 v_z}{\partial \theta^2} + \frac{1}{r} \frac{\partial v_z}{\partial r} + \frac{\partial^2 v_z}{\partial z^2}. \quad (2.34.14)$$

2.35 SPHERICAL COORDINATES

In Figure 2.35-1, we show the spherical coordinates (r, θ, ϕ) of a general point P . In this figure, \mathbf{e}_r , \mathbf{e}_θ and \mathbf{e}_ϕ are unit vectors in the direction of increasing r , θ and ϕ , respectively.

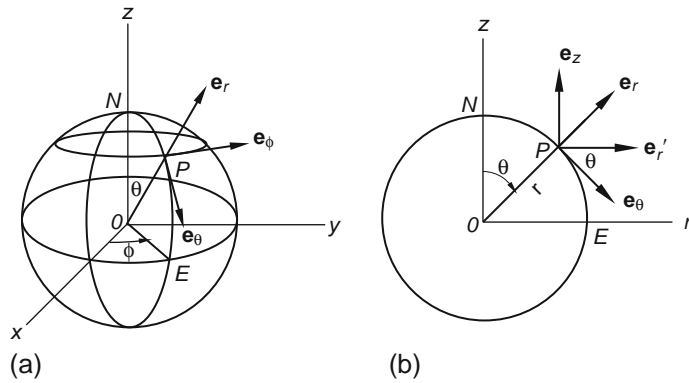

FIGURE 2.35-1

The position vector for the point P can be written as

$$\mathbf{r} = r\mathbf{e}_r, \quad (2.35.1)$$

where r is the magnitude of the vector \mathbf{r} . Thus,

$$d\mathbf{r} = dr\mathbf{e}_r + r d\mathbf{e}_r. \quad (2.35.2)$$

To evaluate $d\mathbf{e}_r$, we note from Figure 2.35-1(b) that

$$\mathbf{e}_r = \cos\theta\mathbf{e}_z + \sin\theta\mathbf{e}'_r, \quad \mathbf{e}_\theta = \cos\theta\mathbf{e}'_\theta - \sin\theta\mathbf{e}_z, \quad (2.35.3)$$

where \mathbf{e}'_r is the unit vector in the OE (i.e., r') direction (r' is in the xy plane). Thus,

$$d\mathbf{e}_r = -\sin\theta d\theta\mathbf{e}_z + \cos\theta d\mathbf{e}_z + \cos\theta d\theta\mathbf{e}'_r + \sin\theta d\mathbf{e}'_r = (-\sin\theta\mathbf{e}_z + \cos\theta\mathbf{e}'_r)d\theta + \sin\theta d\mathbf{e}'_r,$$

that is,

$$d\mathbf{e}_r = d\theta\mathbf{e}_\theta + \sin\theta d\mathbf{e}'_r. \quad (2.35.4)$$

Now, just as in polar coordinates, due to $d\phi$,

$$d\mathbf{e}'_r = d\phi\mathbf{e}_\phi, \quad (2.35.5)$$

therefore,

$$d\mathbf{e}_r = d\theta\mathbf{e}_\theta + \sin\theta d\phi\mathbf{e}_\phi. \quad (2.35.6)$$

Now, from the second equation of (2.35.3), we have,

$$d\mathbf{e}_\theta = -\sin\theta d\theta\mathbf{e}'_r + \cos\theta d\mathbf{e}'_r - \cos\theta d\theta\mathbf{e}_z = -(\sin\theta\mathbf{e}'_r + \cos\theta\mathbf{e}_z)d\theta + \cos\theta d\mathbf{e}'_r.$$

Using Eq. (2.35.3) and Eq. (2.35.5), the preceding equation becomes

$$d\mathbf{e}_\theta = -\mathbf{e}_r d\theta + \cos\theta d\phi\mathbf{e}_\phi. \quad (2.35.7)$$

From Figure 2.35-1(a) and similar to the polar coordinate, we have

$$d\mathbf{e}_\phi = d\phi(-\mathbf{e}'_r). \quad (2.35.8)$$

With $\mathbf{e}'_r = \cos\theta\mathbf{e}_\theta + \sin\theta\mathbf{e}_r$ (see Figure 2.35-1(b)), the preceding equation becomes

$$d\mathbf{e}_\phi = -\sin\theta d\phi\mathbf{e}_r - \cos\theta d\phi\mathbf{e}_\theta. \quad (2.35.9)$$

Summarizing the preceding, we have

$$d\mathbf{e}_r = d\theta\mathbf{e}_\theta + \sin\theta d\phi\mathbf{e}_\phi, \quad d\mathbf{e}_\theta = -\mathbf{e}_r d\theta + \cos\theta d\phi\mathbf{e}_\phi, \quad d\mathbf{e}_\phi = -\sin\theta d\phi\mathbf{e}_r - \cos\theta d\phi\mathbf{e}_\theta, \quad (2.35.10)$$

and from Eq. (2.35.2), we have

$$d\mathbf{r} = d\mathbf{r}_e + r d\theta\mathbf{e}_\theta + r \sin\theta d\phi\mathbf{e}_\phi. \quad (2.35.11)$$

We can now obtain the components of ∇f , $\nabla\mathbf{v}$, $\text{div } \mathbf{v}$, $\text{curl } \mathbf{v}$, $\text{div } \mathbf{T}$, $\nabla^2 f$, and $\nabla^2 \mathbf{v}$ for spherical coordinates.

(i) Components of ∇f :

Let $f(r, \theta, \phi)$ be a scalar field. By the definition of ∇f , we have

$$df = \nabla f \cdot d\mathbf{r} = [(\nabla f)_r \mathbf{e}_r + (\nabla f)_\theta \mathbf{e}_\theta + (\nabla f)_\phi \mathbf{e}_\phi] \cdot (d\mathbf{r}_e + r d\theta\mathbf{e}_\theta + r \sin\theta d\phi\mathbf{e}_\phi), \quad (2.35.12)$$

that is,

$$df = (\nabla f)_r dr + (\nabla f)_\theta r d\theta + (\nabla f)_\phi r \sin\theta d\phi. \quad (2.35.13)$$

From calculus, the total derivative of df is

$$df = \frac{\partial f}{\partial r} dr + \frac{\partial f}{\partial \theta} d\theta + \frac{\partial f}{\partial \phi} d\phi. \quad (2.35.14)$$

Comparing Eq. (2.35.14) and Eq. (2.35.13), we have

$$(\nabla f)_r = \frac{\partial f}{\partial r}, \quad (\nabla f)_\theta = \frac{1}{r} \frac{\partial f}{\partial \theta}, \quad (\nabla f)_\phi = \frac{1}{r \sin\theta} \frac{\partial f}{\partial \phi}. \quad (2.35.15)$$

(ii) Components of $\nabla\mathbf{v}$:

Let the vector field be represented by

$$\mathbf{v}(r, \theta, \phi) = v_r(r, \theta, \phi)\mathbf{e}_r + v_\theta(r, \theta, \phi)\mathbf{e}_\theta + v_\phi(r, \theta, \phi)\mathbf{e}_\phi. \quad (2.35.16)$$

Letting $\mathbf{T} = \nabla \mathbf{v}$, we have

$$d\mathbf{v} = \mathbf{T}d\mathbf{r} = \mathbf{T}(dr\mathbf{e}_r + r d\theta\mathbf{e}_\theta + r \sin\theta d\phi\mathbf{e}_\phi) = dr\mathbf{T}\mathbf{e}_r + r d\theta\mathbf{T}\mathbf{e}_\theta + r \sin\theta d\phi\mathbf{T}\mathbf{e}_\phi. \quad (2.35.17)$$

By the definition of components of a tensor \mathbf{T} in spherical coordinates, we have

$$\begin{aligned} \mathbf{T}\mathbf{e}_r &= T_{rr}\mathbf{e}_r + T_{r\theta}\mathbf{e}_\theta + T_{r\phi}\mathbf{e}_\phi, \\ \mathbf{T}\mathbf{e}_\theta &= T_{r\theta}\mathbf{e}_r + T_{\theta\theta}\mathbf{e}_\theta + T_{\theta\phi}\mathbf{e}_\phi, \\ \mathbf{T}\mathbf{e}_\phi &= T_{r\phi}\mathbf{e}_r + T_{\theta\phi}\mathbf{e}_\theta + T_{\phi\phi}\mathbf{e}_\phi. \end{aligned} \quad (2.35.18)$$

Substituting these into Eq. (2.35.17), we get

$$d\mathbf{v} = (T_{rr}dr + T_{r\theta}rd\theta + T_{r\phi}r \sin\theta d\phi)\mathbf{e}_r + (T_{\theta\theta}rd\theta + T_{\theta r}dr + T_{\theta\phi}r \sin\theta d\phi)\mathbf{e}_\theta + (T_{\phi r}dr + T_{\phi\theta}rd\theta + T_{\phi\phi}r \sin\theta d\phi)\mathbf{e}_\phi. \quad (2.35.19)$$

We also have, from Eq. (2.35.16),

$$d\mathbf{v} = dv_r\mathbf{e}_r + v_r d\mathbf{e}_r + dv_\theta\mathbf{e}_\theta + v_\theta d\mathbf{e}_\theta + dv_\phi\mathbf{e}_\phi + v_\phi d\mathbf{e}_\phi. \quad (2.35.20)$$

Using the expression for the total derivatives:

$$\begin{aligned} dv_r &= \frac{\partial v_r}{\partial r} dr + \frac{\partial v_r}{\partial \theta} d\theta + \frac{\partial v_r}{\partial \phi} d\phi, \\ dv_\theta &= \frac{\partial v_\theta}{\partial r} dr + \frac{\partial v_\theta}{\partial \theta} d\theta + \frac{\partial v_\theta}{\partial \phi} d\phi, \\ dv_\phi &= \frac{\partial v_\phi}{\partial r} dr + \frac{\partial v_\phi}{\partial \theta} d\theta + \frac{\partial v_\phi}{\partial \phi} d\phi, \end{aligned} \quad (2.35.21)$$

Eq. (2.35.10) and Eq. (2.35.20) become

$$\begin{aligned} d\mathbf{v} &= \left\{ \frac{\partial v_r}{\partial r} dr + \left(\frac{\partial v_r}{\partial \theta} - v_\theta \right) d\theta + \left(\frac{\partial v_r}{\partial \phi} - v_\phi \sin\theta \right) d\phi \right\} \mathbf{e}_r \\ &+ \left\{ \frac{\partial v_\theta}{\partial r} dr + \left(v_r + \frac{\partial v_\theta}{\partial \theta} \right) d\theta + \left(\frac{\partial v_\theta}{\partial \phi} - v_\phi \cos\theta \right) d\phi \right\} \mathbf{e}_\theta \\ &+ \left\{ \frac{\partial v_\phi}{\partial r} dr + \frac{\partial v_\phi}{\partial \theta} d\theta + \left(\frac{\partial v_\phi}{\partial \phi} + v_r \sin\theta + v_\theta \cos\theta \right) d\phi \right\} \mathbf{e}_\phi. \end{aligned} \quad (2.35.22)$$

Now, comparing Eq. (2.35.22) with Eq. (2.35.19), we have

$$\begin{aligned} (T_{rr}dr + T_{r\theta}rd\theta + T_{r\phi}r \sin\theta d\phi) &= \left\{ \frac{\partial v_r}{\partial r} dr + \left(\frac{\partial v_r}{\partial \theta} - v_\theta \right) d\theta + \left(\frac{\partial v_r}{\partial \phi} - v_\phi \sin\theta \right) d\phi \right\}, \\ (T_{\theta r}dr + T_{\theta\theta}rd\theta + T_{\theta\phi}r \sin\theta d\phi) &= \left\{ \frac{\partial v_\theta}{\partial r} dr + \left(v_r + \frac{\partial v_\theta}{\partial \theta} \right) d\theta + \left(\frac{\partial v_\theta}{\partial \phi} - v_\phi \cos\theta \right) d\phi \right\}, \\ (T_{\phi r}dr + T_{\phi\theta}rd\theta + T_{\phi\phi}r \sin\theta d\phi) &= \left\{ \frac{\partial v_\phi}{\partial r} dr + \frac{\partial v_\phi}{\partial \theta} d\theta + \left(\frac{\partial v_\phi}{\partial \phi} + v_r \sin\theta + v_\theta \cos\theta \right) d\phi \right\}. \end{aligned} \quad (2.35.23)$$

These equations must be valid for arbitrary values of dr , $d\theta$ and $d\phi$, therefore,

$$\begin{aligned}
 T_{rr} &= \frac{\partial v_r}{\partial r}, & T_{r\theta}r &= \left(\frac{\partial v_r}{\partial \theta} - v_\theta \right), & T_{r\phi}r \sin \theta &= \left(\frac{\partial v_r}{\partial \phi} - v_\phi \sin \theta \right), \\
 T_{\theta r} &= \frac{\partial v_\theta}{\partial r}, & T_{\theta\theta}r &= \left(v_r + \frac{\partial v_\theta}{\partial \theta} \right), & T_{\theta\phi}r \sin \theta &= \left(\frac{\partial v_\theta}{\partial \phi} - v_\phi \cos \theta \right), \\
 T_{\phi r} &= \frac{\partial v_\phi}{\partial r}, & T_{\phi\theta}r &= \frac{\partial v_\phi}{\partial \theta}, & T_{\phi\phi}r \sin \theta &= \left(\frac{\partial v_\phi}{\partial \phi} + v_r \sin \theta + v_\theta \cos \theta \right).
 \end{aligned} \tag{2.35.24}$$

In matrix form, we have

$$[\nabla \mathbf{v}] = \begin{bmatrix} \frac{\partial v_r}{\partial r} & \frac{1}{r} \frac{\partial v_r}{\partial \theta} - \frac{v_\theta}{r} & \frac{1}{r \sin \theta} \frac{\partial v_r}{\partial \phi} - \frac{v_\phi}{r} \\ \frac{\partial v_\theta}{\partial r} & \frac{1}{r} \frac{\partial v_\theta}{\partial \theta} + \frac{v_r}{r} & \frac{1}{r \sin \theta} \frac{\partial v_\theta}{\partial \phi} - \frac{v_\phi \cot \theta}{r} \\ \frac{\partial v_\phi}{\partial r} & \frac{1}{r} \frac{\partial v_\phi}{\partial \theta} & \frac{1}{r \sin \theta} \frac{\partial v_\phi}{\partial \phi} + \frac{v_r}{r} + \frac{v_\theta \cot \theta}{r} \end{bmatrix}. \tag{2.35.25}$$

(iii) $\text{div } \mathbf{v}$:

Using Eq. (2.35.25), we obtain

$$\begin{aligned}
 \text{div } \mathbf{v} &= \text{tr}(\nabla \mathbf{v}) = \frac{\partial v_r}{\partial r} + \frac{1}{r} \frac{\partial v_\theta}{\partial \theta} + \frac{1}{r \sin \theta} \frac{\partial v_\phi}{\partial \phi} + \frac{2v_r}{r} + \frac{v_\theta \cot \theta}{r} \\
 &= \frac{1}{r^2} \frac{\partial(r^2 v_r)}{\partial r} + \frac{1}{r \sin \theta} \frac{\partial(v_\theta \sin \theta)}{\partial \theta} + \frac{1}{r \sin \theta} \frac{\partial v_\phi}{\partial \phi}.
 \end{aligned} \tag{2.35.26}$$

(iv) Components of $\text{curl } \mathbf{v}$:

The vector $\text{curl } \mathbf{v} = \text{twice the dual vector of } (\nabla \mathbf{v})^A$, therefore

$$\begin{aligned}
 \text{curl } \mathbf{v} &= \left\{ \frac{v_\phi \cot \theta}{r} + \frac{1}{r} \frac{\partial v_\phi}{\partial \theta} - \frac{1}{r \sin \theta} \frac{\partial v_\theta}{\partial \phi} \right\} \mathbf{e}_r + \left\{ \frac{1}{r \sin \theta} \frac{\partial v_r}{\partial \phi} - \frac{1}{r} \frac{\partial(rv_\phi)}{\partial r} \right\} \mathbf{e}_\theta \\
 &\quad + \left\{ \frac{1}{r} \frac{\partial(rv_\theta)}{\partial r} - \frac{1}{r} \frac{\partial v_r}{\partial \theta} \right\} \mathbf{e}_\phi.
 \end{aligned} \tag{2.35.27}$$

(v) Components of $\text{div } \mathbf{T}$:

Using the definition of $\text{div } \mathbf{T}$ given in Eq. (2.33.27) and take $\mathbf{a} = \mathbf{e}_r$, we have

$$(\text{div } \mathbf{T})_r = \text{div}(\mathbf{T}^T \mathbf{e}_r) - \text{tr}((\nabla \mathbf{e}_r) \mathbf{T}^T). \tag{2.35.28}$$

To evaluate the first term on the right-hand side, we note that

$$\mathbf{T}^T \mathbf{e}_r = T_{rr} \mathbf{e}_r + T_{r\theta} \mathbf{e}_\theta + T_{r\phi} \mathbf{e}_\phi, \tag{2.35.29}$$

so that by using Eq. (2.35.26) for the divergence of a vector in spherical coordinates, we obtain,

$$\operatorname{div}(\mathbf{T}^T \mathbf{e}_r) = \frac{1}{r^2} \frac{\partial(r^2 T_{rr})}{\partial r} + \frac{1}{r \sin \theta} \frac{\partial(T_{r\theta} \sin \theta)}{\partial \theta} + \frac{1}{r \sin \theta} \frac{\partial T_{r\phi}}{\partial \phi}. \quad (2.35.30)$$

To evaluate the second term in Eq. (2.35.28), we first used Eq. (2.35.25) to evaluate $\nabla \mathbf{e}_r$, then calculate $(\nabla \mathbf{e}_r) \mathbf{T}^T$:

$$[\nabla \mathbf{e}_r] = \begin{bmatrix} 0 & 0 & 0 \\ 0 & 1/r & 0 \\ 0 & 0 & 1/r \end{bmatrix}, \quad [(\nabla \mathbf{e}_r) \mathbf{T}^T] = \begin{bmatrix} 0 & 0 & 0 \\ T_{r\theta}/r & T_{\theta\theta}/r & T_{\phi\theta}/r \\ T_{r\phi}/r & T_{\theta\phi}/r & T_{\phi\phi}/r \end{bmatrix} \quad (2.35.31)$$

thus,

$$\operatorname{tr}((\nabla \mathbf{e}_r) \mathbf{T}^T) = \frac{T_{\theta\theta}}{r} + \frac{T_{\phi\phi}}{r}. \quad (2.35.32)$$

Substituting Eq. (2.35.32) and Eq. (2.35.30) into Eq. (2.35.28), we obtain,

$$(\operatorname{div} \mathbf{T})_r = \frac{1}{r^2} \frac{\partial(r^2 T_{rr})}{\partial r} + \frac{1}{r \sin \theta} \frac{\partial(T_{r\theta} \sin \theta)}{\partial \theta} + \frac{1}{r \sin \theta} \frac{\partial T_{r\phi}}{\partial \phi} - \frac{T_{\theta\theta} + T_{\phi\phi}}{r}. \quad (2.35.33)$$

In a similar manner, we can obtain (see Prob. 2.75)

$$(\operatorname{div} \mathbf{T})_\theta = \frac{1}{r^3} \frac{\partial(r^3 T_{\theta r})}{\partial r} + \frac{1}{r \sin \theta} \frac{\partial(T_{\theta\theta} \sin \theta)}{\partial \theta} + \frac{1}{r \sin \theta} \frac{\partial T_{\theta\phi}}{\partial \phi} + \frac{T_{r\theta} - T_{\theta r} - T_{\phi\theta} \cot \theta}{r} \quad (2.35.34)$$

$$(\operatorname{div} \mathbf{T})_\phi = \frac{1}{r^3} \frac{\partial(r^3 T_{\phi r})}{\partial r} + \frac{1}{r \sin \theta} \frac{\partial(T_{\phi\theta} \sin \theta)}{\partial \theta} + \frac{1}{r \sin \theta} \frac{\partial T_{\phi\phi}}{\partial \phi} + \frac{T_{r\phi} - T_{\phi r} + T_{\theta\phi} \cot \theta}{r}. \quad (2.35.35)$$

(vi) Laplacian of f :
From

$$\begin{aligned} \operatorname{div} \mathbf{v} &= \frac{1}{r^2} \frac{\partial(r^2 v_r)}{\partial r} + \frac{1}{r \sin \theta} \frac{\partial v_\theta \sin \theta}{\partial \theta} + \frac{1}{r \sin \theta} \frac{\partial v_\phi}{\partial \phi}, \\ \nabla f &= \frac{\partial f}{\partial r} \mathbf{e}_r + \frac{1}{r} \frac{\partial f}{\partial \theta} \mathbf{e}_\theta + \frac{1}{r \sin \theta} \frac{\partial f}{\partial \phi} \mathbf{e}_\phi, \end{aligned} \quad (2.35.36)$$

we have

$$\begin{aligned} \nabla^2 f &= \operatorname{div}(\nabla f) = \frac{1}{r^2} \frac{\partial}{\partial r} \left(r^2 \frac{\partial f}{\partial r} \right) + \frac{1}{r \sin \theta} \frac{\partial}{\partial \theta} \left(\frac{1}{r} \frac{\partial f}{\partial \theta} \sin \theta \right) + \frac{1}{r \sin \theta} \frac{\partial}{\partial \phi} \left(\frac{1}{r \sin \theta} \frac{\partial f}{\partial \phi} \right) \\ &= \frac{\partial^2 f}{\partial r^2} + \frac{2}{r} \frac{\partial f}{\partial r} + \frac{1}{r^2} \left(\frac{\partial^2 f}{\partial \theta^2} \right) + \frac{\cot \theta}{r^2} \frac{\partial f}{\partial \theta} + \frac{1}{r^2 \sin^2 \theta} \left(\frac{\partial^2 f}{\partial \phi^2} \right). \end{aligned} \quad (2.35.37)$$

(vii) Laplacian of a vector function \mathbf{v} :

It can be obtained (see Prob. 2.75)

$$\begin{aligned} \nabla(\operatorname{div} \mathbf{v}) &= \left(\frac{1}{r^2} \frac{\partial^2 r^2 v_r}{\partial r^2} - \frac{2}{r^3} \frac{\partial r^2 v_r}{\partial r} + \frac{1}{r \sin \theta} \left(\frac{\partial^2 v_\theta \sin \theta}{\partial r \partial \theta} + \frac{\partial^2 v_\phi}{\partial r \partial \phi} \right) - \frac{1}{r^2 \sin \theta} \left(\frac{\partial v_\theta \sin \theta}{\partial \theta} + \frac{\partial v_\phi}{\partial \phi} \right) \right) \mathbf{e}_r \\ &+ \left(\frac{1}{r^3} \frac{\partial^2 r^2 v_r}{\partial \theta \partial r} + \frac{1}{r^2 \sin \theta} \left(\frac{\partial^2 v_\theta \sin \theta}{\partial \theta^2} + \frac{\partial^2 v_\theta \sin \theta}{\partial \theta^2} \right) - \frac{1}{r^2} \left(\frac{\cos \theta}{\sin^2 \theta} \right) \frac{\partial v_\theta \sin \theta}{\partial \theta} + \frac{1}{r^2} \frac{\partial}{\partial \theta} \frac{1}{\sin \theta} \frac{\partial v_\phi}{\partial \phi} \right) \mathbf{e}_\theta \\ &+ \left(\frac{1}{r^3 \sin \theta} \frac{\partial}{\partial \phi} \frac{\partial (r^2 v_r)}{\partial r} + \frac{1}{r^2 \sin^2 \theta} \frac{\partial^2 (v_\theta \sin \theta)}{\partial \phi \partial \theta} + \frac{1}{r^2 \sin^2 \theta} \frac{\partial^2 v_\phi}{\partial \phi^2} \right) \mathbf{e}_\phi, \end{aligned} \quad (2.35.38)$$

and

$$\begin{aligned} \operatorname{curl} \operatorname{curl} \mathbf{v} &= \left\{ \frac{1}{r^2} \left(\frac{\partial^2 r v_\theta}{\partial \theta \partial r} - \frac{\partial^2 v_r}{\partial \theta^2} \right) + \frac{\cot \theta}{r} \left(\frac{1}{r} \frac{\partial r v_\theta}{\partial r} - \frac{1}{r} \frac{\partial v_r}{\partial \theta} \right) - \left(\frac{1}{r^2 \sin^2 \theta} \frac{\partial^2 v_r}{\partial \phi^2} - \frac{1}{r^2 \sin \theta} \frac{\partial^2 r v_\phi}{\partial \phi \partial r} \right) \right\} \mathbf{e}_r \\ &+ \left\{ \frac{1}{r^2 \sin^2 \theta} \left(\frac{\partial^2 v_\phi \sin \theta}{\partial \phi \partial \theta} - \frac{\partial^2 v_\theta}{\partial \phi^2} \right) - \frac{1}{r^2} \left(\frac{\partial r v_\theta}{\partial r} - \frac{\partial v_r}{\partial \theta} \right) - \left(\frac{1}{r} \frac{\partial^2 r v_\theta}{\partial r^2} - \frac{1}{r^2} \frac{\partial r v_\theta}{\partial r} - \frac{1}{r} \frac{\partial^2 v_r}{\partial r \partial \theta} + \frac{1}{r^2} \frac{\partial v_r}{\partial \theta} \right) \right\} \mathbf{e}_\theta \\ &+ \left\{ \left(\frac{1}{r \sin \theta} \frac{\partial v_r}{\partial r \partial \phi} - \frac{1}{r^2} \frac{1}{\sin \theta} \frac{\partial v_r}{\partial \phi} - \frac{1}{r} \frac{\partial^2 r v_\phi}{\partial r^2} + \frac{1}{r^2} \frac{\partial r v_\phi}{\partial r} \right) + \frac{1}{r^2} \left(\frac{1}{\sin \theta} \frac{\partial v_r}{\partial \phi} - \frac{\partial r v_\phi}{\partial r} \right) \right. \\ &\left. + \left(-\frac{1}{r^2} \frac{1}{\sin \theta} \left(-v_\phi \sin \theta + \sin \theta \frac{\partial^2 v_\phi}{\partial \theta^2} - \frac{\partial^2 v_\theta}{\partial \theta \partial \phi} \right) + \frac{\cos \theta}{r^2 \sin^2 \theta} \left(\frac{\partial v_\phi \sin \theta}{\partial \theta} - \frac{\partial v_\theta}{\partial \phi} \right) \right) \right\} \mathbf{e}_\phi. \end{aligned} \quad (2.35.39)$$

Thus, $\nabla^2 \mathbf{v} = \nabla(\operatorname{div} \mathbf{v}) - \operatorname{curl} \operatorname{curl} \mathbf{v}$ leads to:

$$(\nabla^2 \mathbf{v})_r = \left(\frac{1}{r^2} \frac{\partial^2 r^2 v_r}{\partial r^2} - \frac{2}{r^3} \frac{\partial r^2 v_r}{\partial r} + \frac{1}{r^2} \frac{\partial^2 v_r}{\partial \theta^2} + \frac{\cot \theta}{r^2} \frac{\partial v_r}{\partial \theta} + \frac{1}{r^2 \sin^2 \theta} \frac{\partial^2 v_r}{\partial \phi^2} - \frac{2}{r^2 \sin \theta} \frac{\partial v_\theta \sin \theta}{\partial \theta} \right), \quad (2.35.40)$$

$$(\nabla^2 \mathbf{v})_\theta = \left(\frac{1}{r^2} \frac{\partial}{\partial r} \left(r^2 \frac{\partial v_\theta}{\partial r} \right) + \frac{1}{r^2} \frac{\partial}{\partial \theta} \left\{ \frac{1}{\sin \theta} \frac{\partial}{\partial \theta} (v_\theta \sin \theta) \right\} + \frac{1}{r^2 \sin^2 \theta} \frac{\partial^2 v_\theta}{\partial \phi^2} \right), \quad (2.35.41)$$

$$(\nabla^2 \mathbf{v})_\phi = \left(\frac{1}{r^2} \frac{\partial}{\partial r} \left(r^2 \frac{\partial v_\phi}{\partial r} \right) + \frac{1}{r^2} \frac{\partial}{\partial \theta} \left\{ \frac{1}{\sin \theta} \frac{\partial}{\partial \theta} (v_\phi \sin \theta) \right\} + \frac{1}{r^2 \sin^2 \theta} \frac{\partial^2 v_\phi}{\partial \phi^2} \right). \quad (2.35.42)$$

PROBLEMS FOR PART D

2.70 Calculate $\operatorname{div} \mathbf{u}$ for the following vector field in cylindrical coordinates:

(a) $u_r = u_\theta = 0, \quad u_z = A + Br^2.$

(b) $u_r = \sin \theta / r, \quad u_\theta = u_z = 0.$

(c) $u_r = r^2 \sin \theta / 2, \quad u_\theta = r^2 \cos \theta / 2, \quad u_z = 0.$

2.71 Calculate $\nabla \mathbf{u}$ for the following vector field in cylindrical coordinates:

$$u_r = A/r, \quad u_\theta = Br, \quad u_z = 0.$$

2.72 Calculate $\operatorname{div} \mathbf{u}$ for the following vector field in spherical coordinates:

$$u_r = Ar + \frac{B}{r^2}, \quad u_\theta = u_\phi = 0.$$

2.73 Calculate $\nabla \mathbf{u}$ for the following vector field in spherical coordinates:

$$u_r = Ar + B/r^2, \quad u_\theta = u_\phi = 0.$$

2.74 From the definition of the Laplacian of a vector, $\nabla^2 \mathbf{v} = \nabla(\operatorname{div} \mathbf{v}) - \operatorname{curl} \operatorname{curl} \mathbf{v}$, derive the following results in cylindrical coordinates:

$$\begin{aligned} (\nabla^2 \mathbf{v})_r &= \left(\frac{\partial^2 v_r}{\partial r^2} + \frac{1}{r^2} \frac{\partial^2 v_r}{\partial \theta^2} + \frac{\partial^2 v_r}{\partial z^2} - \frac{2}{r^2} \frac{\partial v_\theta}{\partial \theta} + \frac{1}{r} \frac{\partial v_r}{\partial r} - \frac{v_r}{r^2} \right) \quad \text{and} \\ (\nabla^2 \mathbf{v})_\theta &= \frac{\partial^2 v_\theta}{\partial r^2} + \frac{1}{r^2} \frac{\partial^2 v_\theta}{\partial \theta^2} + \frac{\partial^2 v_\theta}{\partial z^2} + \frac{1}{r} \frac{\partial v_\theta}{\partial r} + \frac{2}{r^2} \frac{\partial v_r}{\partial \theta} - \frac{v_\theta}{r^2}. \end{aligned}$$

2.75 From the definition of the Laplacian of a vector, $\nabla^2 \mathbf{v} = \nabla(\operatorname{div} \mathbf{v}) - \operatorname{curl} \operatorname{curl} \mathbf{v}$, derive the following result in spherical coordinates:

$$(\nabla^2 \mathbf{v})_r = \left(\frac{1}{r^2} \frac{\partial^2 r^2 v_r}{\partial r^2} - \frac{2}{r^3} \frac{\partial r^2 v_r}{\partial r} + \frac{1}{r^2} \frac{\partial^2 v_r}{\partial \theta^2} + \frac{\cot \theta}{r^2} \frac{\partial v_r}{\partial \theta} + \frac{1}{r^2 \sin^2 \theta} \frac{\partial^2 v_r}{\partial \phi^2} - \frac{2}{r^2 \sin \theta} \frac{\partial v_\theta \sin \theta}{\partial \theta} - \frac{2}{r^2 \sin \theta} \frac{\partial v_\phi}{\partial \phi} \right).$$

2.76 From the equation $(\operatorname{div} \mathbf{T}) \cdot \mathbf{a} = \operatorname{div}(\mathbf{T}^T \mathbf{a}) - \operatorname{tr}(\mathbf{T}^T \nabla \mathbf{a})$ [see Eq. (2.29.3)], verify that in polar coordinates the θ -component of the vector $(\operatorname{div} \mathbf{T})$ is:

$$(\operatorname{div} \mathbf{T})_\theta = \frac{\partial T_{\theta r}}{\partial r} + \frac{1}{r} \frac{\partial T_{\theta \theta}}{\partial \theta} + \frac{T_{r\theta} + T_{\theta r}}{r}.$$

2.77 Calculate $\operatorname{div} \mathbf{T}$ for the following tensor field in cylindrical coordinates:

$$T_{rr} = A + \frac{B}{r^2}, \quad T_{\theta\theta} = A - \frac{B}{r^2}, \quad T_{zz} = \text{constant}, \quad T_{r\theta} = T_{\theta r} = T_{rz} = T_{zr} = T_{\theta z} = T_{z\theta} = 0.$$

2.78 Calculate $\operatorname{div} \mathbf{T}$ for the following tensor field in cylindrical coordinates:

$$T_{rr} = \frac{Az}{R^3} - \frac{3Br^2z}{R^5}, \quad T_{\theta\theta} = \frac{Az}{R^3}, \quad T_{zz} = -\left(\frac{Az}{R^3} + \frac{3Bz^3}{R^5}\right), \quad T_{rz} = T_{zr} = -\left(\frac{Ar}{R^3} + \frac{3Brz^2}{R^5}\right),$$

$$T_{r\theta} = T_{\theta r} = T_{\theta z} = T_{z\theta} = 0, \quad R^2 = r^2 + z^2.$$

2.79 Calculate $\operatorname{div} \mathbf{T}$ for the following tensor field in spherical coordinates:

$$T_{rr} = A - \frac{2B}{r^3}, \quad T_{\theta\theta} = T_{\phi\phi} = A + \frac{B}{r^3}, \quad T_{r\theta} = T_{\theta r} = T_{\theta\phi} = T_{\phi\theta} = T_{r\phi} = T_{\phi r} = 0.$$

2.80 From the equation $(\operatorname{div} \mathbf{T}) \cdot \mathbf{a} = \operatorname{div}(\mathbf{T}^T \mathbf{a}) - \operatorname{tr}(\mathbf{T}^T \nabla \mathbf{a})$ [see Eq. (2.29.3)], verify that in spherical coordinates the θ -component of the vector $(\operatorname{div} \mathbf{T})$ is:

$$(\operatorname{div} \mathbf{T})_{\theta} = \frac{1}{r^3} \frac{\partial(r^3 T_{\theta r})}{\partial r} + \frac{1}{r \sin \theta} \frac{\partial(T_{\theta\theta} \sin \theta)}{\partial \theta} + \frac{1}{r \sin \theta} \frac{\partial T_{\theta\phi}}{\partial \phi} + \frac{T_{r\theta} - T_{\theta r} - T_{\phi\phi} \cot \theta}{r}.$$

Kinematics of a Continuum

The branch of mechanics in which materials are treated as continuous is known as *continuum mechanics*. Thus, in this theory, one speaks of an infinitesimal volume of material, the totality of which forms a body. One also speaks of a particle in a continuum, meaning, in fact, an infinitesimal volume of material. This chapter is concerned with the kinematics of such particles.

3.1 DESCRIPTION OF MOTIONS OF A CONTINUUM

In particle kinematics, the path line of a particle is described by a vector function of time t ,

$$\mathbf{r} = \mathbf{r}(t), \quad (3.1.1)$$

where $\mathbf{r}(t) = x_1(t)\mathbf{e}_1 + x_2(t)\mathbf{e}_2 + x_3(t)\mathbf{e}_3$ is the position vector. In component form, the previous equation reads:

$$x_1 = x_1(t), \quad x_2 = x_2(t), \quad x_3 = x_3(t). \quad (3.1.2)$$

If there are N particles, there are N path lines, each of which is described by one of the equations:

$$\mathbf{r}_n = \mathbf{r}_n(t), \quad n = 1, 2, 3 \dots N. \quad (3.1.3)$$

That is, for the particle number 1, the path line is given by $\mathbf{r}_1(t)$, for the particle number 2, it is given by $\mathbf{r}_2(t)$, etc.

For a continuum, there are infinitely many particles. Therefore, it is not possible to identify particles by assigning each of them a number in the same way as in the kinematics of particles. However, it is possible to identify them by the position they occupy at some reference time t_0 .

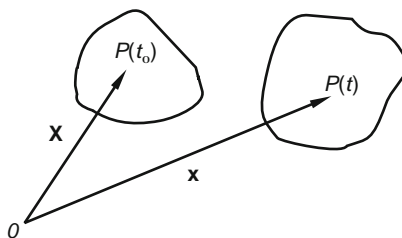

FIGURE 3.1-1

For example, if a particle of a continuum was at the position (1, 2, 3) at time $t = 0$, the set of coordinates (1, 2, 3) can be used to identify this particle. In general, therefore, if a particle of a continuum was at the position (X_1, X_2, X_3) at the reference time t_0 , the set of coordinates (X_1, X_2, X_3) can be used to identify this particle. Thus, in general, the path lines of every particle in a continuum can be described by a vector equation of the form

$$\mathbf{x} = \mathbf{x}(\mathbf{X}, t) \quad \text{with} \quad \mathbf{X} = \mathbf{x}(\mathbf{X}, t_0), \quad (3.1.4)$$

where $\mathbf{x} = x_1\mathbf{e}_1 + x_2\mathbf{e}_2 + x_3\mathbf{e}_3$ is the position vector at time t for the particle P (see Figure 3.1-1), which was at $\mathbf{X} = X_1\mathbf{e}_1 + X_2\mathbf{e}_2 + X_3\mathbf{e}_3$ at time t_0 . In component form, Eq. (3.1.4) takes the form:

$$\begin{aligned} x_1 &= x_1(X_1, X_2, X_3, t), & X_1 &= x_1(X_1, X_2, X_3, t_0), \\ x_2 &= x_2(X_1, X_2, X_3, t), & X_2 &= x_2(X_1, X_2, X_3, t_0), \\ x_3 &= x_3(X_1, X_2, X_3, t), & X_3 &= x_3(X_1, X_2, X_3, t_0), \end{aligned} \quad (3.1.5)$$

or

$$x_i = x_i(X_1, X_2, X_3, t) \quad \text{with} \quad X_i = x_i(X_1, X_2, X_3, t_0). \quad (3.1.6)$$

In Eq. (3.1.5), the triple (X_1, X_2, X_3) serves to identify the different particles of the body and is known as the *material coordinates*. Eq. (3.1.5) [or Eq. (3.1.6)] is said to define a *motion* for a continuum; these equations describe the *path line* for every *particle* in the continuum.

Example 3.1.1

Consider the motion

$$\mathbf{x} = \mathbf{X} + ktX_2\mathbf{e}_1, \quad (i)$$

where $\mathbf{x} = x_1\mathbf{e}_1 + x_2\mathbf{e}_2 + x_3\mathbf{e}_3$ is the position vector at time t for a particle P that was at $\mathbf{X} = X_1\mathbf{e}_1 + X_2\mathbf{e}_2 + X_3\mathbf{e}_3$ at $t = 0$. Sketch the configuration at time t for a body which, at $t = 0$, has the shape of a cube of unit sides as shown.

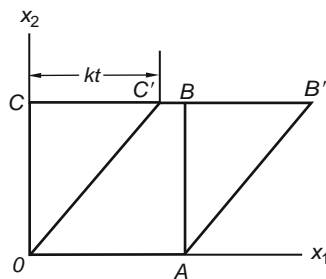

FIGURE 3.1-2

Solution

From Eq. (i), we have

$$x_1 = X_1 + ktX_2, \quad x_2 = X_2, \quad x_3 = X_3. \quad (ii)$$

At $t = 0$, the particle O is located at $(0, 0, 0)$. Thus, for this particle, the material coordinates are

$$X_1 = 0, \quad X_2 = 0, \quad X_3 = 0.$$

Substituting these values for X_i in Eq. (ii), we get, for all time t ,

$$(x_1, x_2, x_3) = (0, 0, 0).$$

In other words, this particle remains at $(0, 0, 0)$ at all times. Similarly, the material coordinates for the particle A are

$$(X_1, X_2, X_3) = (1, 0, 0),$$

and the position for A at time t is

$$(x_1, x_2, x_3) = (1, 0, 0).$$

Thus, the particle A also does not move with time. In fact, since the material coordinates for the points on the material line OA are

$$(X_1, X_2, X_3) = (X_1, 0, 0),$$

for them, the positions at time t are

$$(x_1, x_2, x_3) = (X_1, 0, 0).$$

That is, the whole material line OA is motionless. On the other hand, the material coordinates for the material line CB are

$$(X_1, X_2, X_3) = (X_1, 1, 0),$$

so that according to Eq. (ii)

$$(x_1, x_2, x_3) = (X_1 + kt, 1, 0).$$

In other words, the material line has moved horizontally through a distance of kt (see Figure 3.1-2). The material coordinates for the material line OC are

$$(X_1, X_2, X_3) = (0, X_2, 0),$$

so that for the particles on this line

$$(x_1, x_2, x_3) = (ktX_2, X_2, 0).$$

The fact that $x_1 = ktX_2$ means that the straight material line OC remains a straight line OC' at time t , as shown in Figure 3.1-2. The situation for the material line AB is similar. Thus, at time t , the side view of the cube changes from that of a square to a parallelogram, as shown in Figure 3.1-2.

Since $x_3 = X_3$ at all time for all particles, it is clear that all motions are parallel to the plane $x_3 = 0$. The motion given in this example is known as the *simple shearing motion*.

Example 3.1.2

Let $Y_1 = -X_1$, $Y_2 = X_2$, and $Y_3 = X_3$. Express the simple shearing motion given in Example 3.1.1 in terms of (Y_1, Y_2, Y_3) .

Solution

Straightforward substitutions give

$$x_1 = -Y_1 + ktY_2, \quad x_2 = Y_2, \quad x_3 = Y_3.$$

These equations, i.e., $x_i = x_i(Y_1, Y_2, Y_3, t)$ also describe the simple shearing motion just as the equations given in the previous example. The triples (Y_1, Y_2, Y_3) are also material coordinates in that they also identify the particles in the continuum, although they are not the coordinates of the particles at any time. This example demonstrates the fact that though the positions of the particles at some reference time t_0 can be used as the material coordinates, the material coordinates need not be the positions of the particle at any particular time. However, within this book, all material coordinates will be coordinates of the particles at some reference time.

3.2 MATERIAL DESCRIPTION AND SPATIAL DESCRIPTION

When a continuum is in motion, its temperature Θ , its velocity \mathbf{v} , and its stress tensor \mathbf{T} (to be defined in the next chapter) may change with time. We can describe these changes as follows.

1. Following the particles, i.e., we express Θ , \mathbf{v} , \mathbf{T} as functions of the particles [identified by the material coordinates (X_1, X_2, X_3)] and time t . In other words, we express

$$\begin{aligned}\Theta &= \hat{\Theta}(X_1, X_2, X_3, t), \\ \mathbf{v} &= \hat{\mathbf{v}}(X_1, X_2, X_3, t), \\ \mathbf{T} &= \hat{\mathbf{T}}(X_1, X_2, X_3, t).\end{aligned}\tag{3.2.1}$$

Such a description is known as the *material description*. Other names for it are the *Lagrangian description* and the *reference description*.

2. Observing the changes at fixed locations, i.e., we express Θ , \mathbf{v} , \mathbf{T} as functions of fixed position and time. Thus,

$$\begin{aligned}\Theta &= \tilde{\Theta}(x_1, x_2, x_3, t), \\ \mathbf{v} &= \tilde{\mathbf{v}}(x_1, x_2, x_3, t), \\ \mathbf{T} &= \tilde{\mathbf{T}}(x_1, x_2, x_3, t).\end{aligned}\tag{3.2.2}$$

Such a description is known as a *spatial description* or *Eulerian description*. The triple (x_1, x_2, x_3) locates the fixed position of points in the physical space and is known as the *spatial coordinates*. The spatial coordinates x_i of a particle at any time t are related to the material coordinates X_i of the particle by Eq. (3.1.5). We note that in spatial description, what is described (or measured) is the change of quantities at a fixed location as a function of time. Spatial positions are occupied by different particles at different times. Therefore, the spatial description does not provide direct information regarding changes in particle properties as they move about. The material and spatial descriptions are, of course, related by the motion, Eq. (3.1.4). That is, if the motion is known, one description can be obtained from the other, as illustrated by the following example.

Example 3.2.1

Given the motion of a continuum to be

$$x_1 = X_1 + ktX_2, \quad x_2 = (1 + kt)X_2, \quad x_3 = X_3.\tag{i}$$

If the temperature field is given by the spatial description

$$\Theta = \alpha(x_1 + x_2),\tag{ii}$$

(a) find the material description of temperature and (b) obtain the velocity and the rate of change of temperature for particular material particles and express the answer in both a material and a spatial description.

Solution

(a) Substituting Eq. (i) into Eq. (ii), we obtain the material description for the temperature,

$$\Theta = \alpha(x_1 + x_2) = \alpha X_1 + \alpha(1 + 2kt)X_2. \quad (\text{iii})$$

(b) Since a particular material particle is designated by a specific \mathbf{X} , its velocity will be given by

$$v_i = \left(\frac{\partial X_i}{\partial t} \right)_{X_i\text{-fixed}}, \quad (\text{iv})$$

so that from Eq. (i)

$$v_1 = kX_2, \quad v_2 = kX_2, \quad v_3 = 0. \quad (\text{v})$$

This is the material description of the velocity field. To obtain the spatial description, we make use of Eq. (i) again, where we have

$$X_2 = \frac{x_2}{(1 + kt)}. \quad (\text{vi})$$

Therefore, the spatial description for the velocity field is

$$v_1 = \frac{kx_2}{(1 + kt)}, \quad v_2 = \frac{kx_2}{(1 + kt)}, \quad v_3 = 0. \quad (\text{vii})$$

From Eq. (iii), in material description, the rate of change of temperature for particular material particles is given by

$$\left(\frac{\partial \Theta}{\partial t} \right)_{X_i\text{-fixed}} = 2\alpha kX_2. \quad (\text{viii})$$

To obtain the spatial description, we substitute Eq. (vi) in Eq. (viii):

$$\left(\frac{\partial \Theta}{\partial t} \right)_{X_i\text{-fixed}} = \frac{2\alpha kx_2}{(1 + kt)}.$$

We note that even though the given temperature field is independent of time, each particle experiences changes of temperature since it flows from one spatial position to another.

Example 3.2.2

The position at time t of a particle initially at (X_1, X_2, X_3) is given by the equations

$$x_1 = X_1 + k(X_1 + X_2)t, \quad x_2 = X_2 + k(X_1 + X_2)t, \quad x_3 = X_3. \quad (\text{i})$$

(a) Find the velocity at $t = 2$ for the particle that was at $(1, 1, 0)$ at the reference time.

(b) Find the velocity at $t = 2$ for the particle that is at the position $(1, 1, 0)$ at $t = 2$.

Solution

$$(a) \quad v_1 = \left(\frac{\partial X_1}{\partial t} \right)_{X_i\text{-fixed}} = k(X_1 + X_2), \quad v_2 = \left(\frac{\partial X_2}{\partial t} \right)_{X_i\text{-fixed}} = k(X_1 + X_2), \quad v_3 = 0. \quad (ii)$$

For the particle $(X_1, X_2, X_3) = (1, 1, 0)$, the velocity at $t = 2$ is

$$v_1 = k(1 + 1) = 2k, \quad v_2 = k(1 + 1) = 2k, \quad v_3 = 0,$$

that is,

$$\mathbf{v} = 2k\mathbf{e}_1 + 2k\mathbf{e}_2.$$

(b) We need to calculate the reference position (X_1, X_2, X_3) that was occupied by the particle which, at $t = 2$, is at $(x_1, x_2, x_3) = (1, 1, 0)$. To do this, we substitute this condition into Eq. (i) and solve for (X_1, X_2, X_3) , that is,

$$1 = (1 + 2k)X_1 + 2kX_2, \quad 1 = (1 + 2k)X_2 + 2kX_1,$$

thus,

$$X_1 = \frac{1}{1 + 4k}, \quad X_2 = \frac{1}{1 + 4k}.$$

Substituting these values in Eq. (ii), we obtain

$$v_1 = \frac{2k}{1 + 4k}, \quad v_2 = \frac{2k}{1 + 4k}, \quad v_3 = 0.$$

3.3 MATERIAL DERIVATIVE

The time rate of change of a quantity (such as temperature or velocity or stress tensor) of a material particle is known as a *material derivative*. We shall denote the material derivative by D/Dt .

1. When a material description of a scalar quantity is used, we have

$$\Theta = \hat{\Theta}(X_1, X_2, X_3, t), \quad (3.3.1)$$

then,

$$\frac{D\Theta}{Dt} = \left(\frac{\partial \hat{\Theta}}{\partial t} \right)_{X_i\text{-fixed}}. \quad (3.3.2)$$

2. When a spatial description of the same quantity is used, we have

$$\Theta = \tilde{\Theta}(x_1, x_2, x_3, t), \quad (3.3.3)$$

where x_i , the coordinates of the present positions of material particles at time t are related to the material coordinates by the known motion $x_i = \hat{x}_i(X_1, X_2, X_3, t)$. Then,

$$\frac{D\Theta}{Dt} = \left(\frac{\partial \hat{\Theta}}{\partial t} \right)_{X_i\text{-fixed}} = \left(\frac{\partial \tilde{\Theta}}{\partial x_1} \right) \frac{\partial \hat{x}_1}{\partial t} + \left(\frac{\partial \tilde{\Theta}}{\partial x_2} \right) \frac{\partial \hat{x}_2}{\partial t} + \left(\frac{\partial \tilde{\Theta}}{\partial x_3} \right) \frac{\partial \hat{x}_3}{\partial t} + \left(\frac{\partial \tilde{\Theta}}{\partial t} \right)_{x_i\text{-fixed}}, \quad (3.3.4)$$

where $\frac{\partial \hat{x}_1}{\partial t}$, $\frac{\partial \hat{x}_2}{\partial t}$, and $\frac{\partial \hat{x}_3}{\partial t}$ are to be obtained with fixed values of the X_i 's. When rectangular Cartesian coordinates are used, these are the velocity components v_i of the particle X_i . Thus, the material derivative in rectangular coordinates is

$$\frac{D\Theta}{Dt} = \left(\frac{\partial \hat{\Theta}}{\partial t} \right)_{X_i\text{-fixed}} = \frac{\partial \tilde{\Theta}}{\partial t} + v_1 \left(\frac{\partial \tilde{\Theta}}{\partial x_1} \right) + v_2 \left(\frac{\partial \tilde{\Theta}}{\partial x_2} \right) + v_3 \left(\frac{\partial \tilde{\Theta}}{\partial x_3} \right), \quad (3.3.5)$$

or, in indicial notation,

$$\frac{D\Theta}{Dt} = \left(\frac{\partial \hat{\Theta}}{\partial t} \right)_{X_i\text{-fixed}} = \frac{\partial \tilde{\Theta}}{\partial t} + v_i \left(\frac{\partial \tilde{\Theta}}{\partial x_i} \right), \quad (3.3.6)$$

and in direct notation,

$$\frac{D\Theta}{Dt} = \frac{\partial \tilde{\Theta}}{\partial t} + \mathbf{v} \cdot \nabla \tilde{\Theta}. \quad (3.3.7)$$

It should be emphasized that these equations are for Θ in a spatial description, that is, $\Theta = \tilde{\Theta}(x_1, x_2, x_3, t)$. Note that if the temperature field is independent of time and if the velocity of a particle is perpendicular to $\nabla \tilde{\Theta}$ (i.e., the particle is moving along the path of constant Θ), then, as expected, $\frac{D\Theta}{Dt} = 0$. In the following, for simplicity, whenever it is obvious which kind of function we are dealing with (material and spatial), we shall omit the super-hat or super-tilde on the function.

Note again that Eq. (3.3.5) or Eq. (3.3.6) is valid only for rectangular Cartesian coordinates, whereas Eq. (3.3.7) has the advantage that it is valid for all coordinate systems. For a specific coordinate system, all that is needed is the appropriate expression for the gradient. For example, in cylindrical coordinates (r, θ, z) ,

$$\mathbf{v} = v_r \mathbf{e}_r + v_\theta \mathbf{e}_\theta + v_z \mathbf{e}_z, \quad (3.3.8)$$

and from Eq. (2.34.4)

$$\nabla \Theta = \frac{\partial \Theta}{\partial r} \mathbf{e}_r + \frac{1}{r} \frac{\partial \Theta}{\partial \theta} \mathbf{e}_\theta + \frac{\partial \Theta}{\partial z} \mathbf{e}_z, \quad (3.3.9)$$

thus,

$$\frac{D\Theta}{Dt} = \frac{\partial \Theta}{\partial t} + v_r \frac{\partial \Theta}{\partial r} + \frac{v_\theta}{r} \frac{\partial \Theta}{\partial \theta} + v_z \frac{\partial \Theta}{\partial z}. \quad (3.3.10)$$

In spherical coordinates,

$$\mathbf{v} = v_r \mathbf{e}_r + v_\theta \mathbf{e}_\theta + v_\phi \mathbf{e}_\phi, \quad (3.3.11)$$

and from Eq. (2.35.15)

$$(\nabla\Theta)_r = \frac{\partial\Theta}{\partial r}, \quad (\nabla\Theta)_\theta = \frac{1}{r} \frac{\partial\Theta}{\partial\theta}, \quad (\nabla\Theta)_\phi = \frac{1}{r \sin\theta} \frac{\partial\Theta}{\partial\phi}, \quad (3.3.12)$$

thus,

$$\frac{D\Theta}{Dt} = \frac{\partial\Theta}{\partial t} + v_r \frac{\partial\Theta}{\partial r} + \frac{v_\theta}{r} \frac{\partial\Theta}{\partial\theta} + \frac{v_\phi}{r \sin\theta} \frac{\partial\Theta}{\partial\phi}. \quad (3.3.13)$$

Example 3.3.1

Use Eq. (3.3.7) to obtain $D\Theta/Dt$ for the motion and temperature field given in Example 3.2.1.

Solution

From Example 3.2.1, we have

$$\mathbf{v} = \frac{kx_2}{1+kt} (\mathbf{e}_1 + \mathbf{e}_2) \quad \text{and} \quad \Theta = \alpha(x_1 + x_2).$$

The gradient of Θ is simply $\alpha\mathbf{e}_1 + \alpha\mathbf{e}_2$, therefore,

$$\frac{D\Theta}{Dt} = 0 + \frac{kx_2}{1+kt} (\mathbf{e}_1 + \mathbf{e}_2) \cdot (\alpha\mathbf{e}_1 + \alpha\mathbf{e}_2) = \frac{2\alpha kx_2}{1+kt}.$$

3.4 ACCELERATION OF A PARTICLE

The acceleration of a particle is the rate of change of velocity of the particle. It is, therefore, the material derivative of velocity. If the motion of a continuum is given by Eq. (3.1.4), i.e.,

$$\mathbf{x} = \mathbf{x}(\mathbf{X}, t) \quad \text{with} \quad \mathbf{X} = \mathbf{x}(\mathbf{X}, t_0), \quad (3.4.1)$$

then the velocity \mathbf{v} at time t of a particle \mathbf{X} is given by

$$\mathbf{v} = \left(\frac{\partial\mathbf{x}}{\partial t} \right)_{\mathbf{X}, \text{fixed}} \equiv \frac{D\mathbf{x}}{Dt}, \quad (3.4.2)$$

and the acceleration \mathbf{a} at time t of a particle \mathbf{X} is given by

$$\mathbf{a} = \left(\frac{\partial\mathbf{v}}{\partial t} \right)_{\mathbf{X}, \text{fixed}} \equiv \frac{D\mathbf{v}}{Dt}. \quad (3.4.3)$$

Thus, if the material description of velocity $\mathbf{v}(\mathbf{X}, t)$ is known [or is obtained from Eq. (3.4.2)], then the acceleration is very easily computed, simply taking the partial derivative with respect to time of the function. On the other hand, if only the spatial description of velocity [i.e., $\mathbf{v} = \mathbf{v}(\mathbf{x}, t)$] is known, the computation of acceleration is not as simple. We derive the formulas for its computation in the following:

1. Rectangular Cartesian coordinates (x_1, x_2, x_3) . With

$$\mathbf{v} = v_1(x_1, x_2, x_3, t)\mathbf{e}_1 + v_2(x_1, x_2, x_3, t)\mathbf{e}_2 + v_3(x_1, x_2, x_3, t)\mathbf{e}_3, \quad (3.4.4)$$

we have, since the base vectors \mathbf{e}_1 , \mathbf{e}_2 , and \mathbf{e}_3 are fixed vectors,

$$\mathbf{a} = \frac{D\mathbf{v}}{Dt} = \frac{Dv_1}{Dt} \mathbf{e}_1 + \frac{Dv_2}{Dt} \mathbf{e}_2 + \frac{Dv_3}{Dt} \mathbf{e}_3. \quad (3.4.5)$$

In component form, we have

$$a_i = \frac{Dv_i}{Dt} = \frac{\partial v_i}{\partial t} + v_1 \frac{\partial v_i}{\partial x_1} + v_2 \frac{\partial v_i}{\partial x_2} + v_3 \frac{\partial v_i}{\partial x_3}, \quad (3.4.6)$$

or

$$a_i = \frac{\partial v_i}{\partial t} + v_j \frac{\partial v_i}{\partial x_j}. \quad (3.4.7)$$

In a form valid for all coordinate systems, we have

$$\mathbf{a} = \frac{\partial \mathbf{v}}{\partial t} + (\nabla \mathbf{v}) \mathbf{v}. \quad (3.4.8)^*$$

2. Cylindrical coordinates (r, θ, z) . With

$$\mathbf{v} = v_r(r, \theta, z, t) \mathbf{e}_r + v_\theta(r, \theta, z, t) \mathbf{e}_\theta + v_z(r, \theta, z, t) \mathbf{e}_z \quad (3.4.9)$$

and [see Eq. (2.34.5)]

$$[\nabla \mathbf{v}] = \begin{bmatrix} \frac{\partial v_r}{\partial r} & \frac{1}{r} \left(\frac{\partial v_r}{\partial \theta} - v_\theta \right) & \frac{\partial v_r}{\partial z} \\ \frac{\partial v_\theta}{\partial r} & \frac{1}{r} \left(\frac{\partial v_\theta}{\partial \theta} + v_r \right) & \frac{\partial v_\theta}{\partial z} \\ \frac{\partial v_z}{\partial r} & \frac{1}{r} \frac{\partial v_z}{\partial \theta} & \frac{\partial v_z}{\partial z} \end{bmatrix}, \quad (3.4.10)$$

we have

$$\begin{bmatrix} a_r \\ a_\theta \\ a_z \end{bmatrix} = \begin{bmatrix} \frac{\partial v_r}{\partial t} \\ \frac{\partial v_\theta}{\partial t} \\ \frac{\partial v_z}{\partial t} \end{bmatrix} + \begin{bmatrix} \frac{\partial v_r}{\partial r} & \frac{1}{r} \left(\frac{\partial v_r}{\partial \theta} - v_\theta \right) & \frac{\partial v_r}{\partial z} \\ \frac{\partial v_\theta}{\partial r} & \frac{1}{r} \left(\frac{\partial v_\theta}{\partial \theta} + v_r \right) & \frac{\partial v_\theta}{\partial z} \\ \frac{\partial v_z}{\partial r} & \frac{1}{r} \frac{\partial v_z}{\partial \theta} & \frac{\partial v_z}{\partial z} \end{bmatrix} \begin{bmatrix} v_r \\ v_\theta \\ v_z \end{bmatrix}, \quad (3.4.11)$$

*In dyadic notation, the preceding equation is written as $\mathbf{a} = \frac{\partial \mathbf{v}}{\partial t} + \mathbf{v} \cdot (\tilde{\nabla} \mathbf{v})$, where $\tilde{\nabla} = (\mathbf{e}_m \partial / \partial x_m)$.

thus,

$$\begin{aligned}
 a_r &= \frac{\partial v_r}{\partial t} + v_r \frac{\partial v_r}{\partial r} + \frac{v_\theta}{r} \left(\frac{\partial v_r}{\partial \theta} - v_\theta \right) + v_z \frac{\partial v_r}{\partial z}, \\
 a_\theta &= \frac{\partial v_\theta}{\partial t} + v_r \frac{\partial v_\theta}{\partial r} + \frac{v_\theta}{r} \left(\frac{\partial v_\theta}{\partial \theta} + v_r \right) + v_z \frac{\partial v_\theta}{\partial z}, \\
 a_z &= \frac{\partial v_z}{\partial t} + v_r \frac{\partial v_z}{\partial r} + \frac{v_\theta}{r} \frac{\partial v_z}{\partial \theta} + v_z \frac{\partial v_z}{\partial z}.
 \end{aligned} \tag{3.4.12}$$

3. Spherical coordinates (r, θ, ϕ) . With

$$\mathbf{v} = v_r(r, \theta, \phi, t)\mathbf{e}_r + v_\theta(r, \theta, \phi, t)\mathbf{e}_\theta + v_\phi(r, \theta, \phi, t)\mathbf{e}_\phi \tag{3.4.13}$$

and [see Eq. (2.35.25)],

$$[\nabla \mathbf{v}] = \begin{bmatrix} \frac{\partial v_r}{\partial r} & \left(\frac{1}{r} \frac{\partial v_r}{\partial \theta} - \frac{v_\theta}{r} \right) & \left(\frac{1}{r \sin \theta} \frac{\partial v_r}{\partial \phi} - \frac{v_\phi}{r} \right) \\ \frac{\partial v_\theta}{\partial r} & \left(\frac{1}{r} \frac{\partial v_\theta}{\partial \theta} + \frac{v_r}{r} \right) & \left(\frac{1}{r \sin \theta} \frac{\partial v_\theta}{\partial \phi} - \frac{v_\phi \cot \theta}{r} \right) \\ \frac{\partial v_\phi}{\partial r} & \frac{1}{r} \frac{\partial v_\phi}{\partial \theta} & \left(\frac{1}{r \sin \theta} \frac{\partial v_\phi}{\partial \phi} + \frac{v_r}{r} + \frac{v_\theta \cot \theta}{r} \right) \end{bmatrix}, \tag{3.4.14}$$

we have

$$\begin{bmatrix} a_r \\ a_\theta \\ a_z \end{bmatrix} = \begin{bmatrix} \frac{\partial v_r}{\partial t} \\ \frac{\partial v_\theta}{\partial t} \\ \frac{\partial v_z}{\partial t} \end{bmatrix} + \begin{bmatrix} \frac{\partial v_r}{\partial r} & \frac{1}{r} \left(\frac{\partial v_r}{\partial \theta} - v_\theta \right) & \frac{1}{r \sin \theta} \left(\frac{\partial v_r}{\partial \phi} - v_\phi \sin \theta \right) \\ \frac{\partial v_\theta}{\partial r} & \frac{1}{r} \left(\frac{\partial v_\theta}{\partial \theta} + v_r \right) & \frac{1}{r \sin \theta} \left(\frac{\partial v_\theta}{\partial \phi} - v_\phi \cos \theta \right) \\ \frac{\partial v_\phi}{\partial r} & \frac{1}{r} \frac{\partial v_\phi}{\partial \theta} & \left(\frac{1}{r \sin \theta} \frac{\partial v_\phi}{\partial \phi} + \frac{v_r}{r} + \frac{v_\theta \cot \theta}{r} \right) \end{bmatrix} \begin{bmatrix} v_r \\ v_\theta \\ v_\phi \end{bmatrix}, \tag{3.4.15}$$

and thus,

$$\begin{aligned}
 a_r &= \frac{\partial v_r}{\partial t} + v_r \frac{\partial v_r}{\partial r} + \frac{v_\theta}{r} \left(\frac{\partial v_r}{\partial \theta} - v_\theta \right) + \frac{v_\phi}{r \sin \theta} \left(\frac{\partial v_r}{\partial \phi} - v_\phi \sin \theta \right), \\
 a_\theta &= \frac{\partial v_\theta}{\partial t} + v_r \frac{\partial v_\theta}{\partial r} + \frac{v_\theta}{r} \left(\frac{\partial v_\theta}{\partial \theta} + v_r \right) + \frac{v_\phi}{r \sin \theta} \left(\frac{\partial v_\theta}{\partial \phi} - v_\phi \cos \theta \right), \\
 a_\phi &= \frac{\partial v_\phi}{\partial t} + v_r \frac{\partial v_\phi}{\partial r} + \frac{v_\theta}{r} \frac{\partial v_\phi}{\partial \theta} + \frac{v_\phi}{r \sin \theta} \left(\frac{\partial v_\phi}{\partial \phi} + v_r \sin \theta + v_\theta \cos \theta \right).
 \end{aligned} \tag{3.4.16}$$

Example 3.4.1

(a) Find the velocity field associated with the motion of a rigid body rotating with angular velocity $\boldsymbol{\omega} = \omega \mathbf{e}_3$ in Cartesian and in polar coordinates. (b) Using the velocity field of part (a), evaluate the acceleration field.

Solution

(a) For rigid body rotation

$$\mathbf{v} = \boldsymbol{\omega} \times \mathbf{x}. \quad (\text{i})$$

In Cartesian coordinates,

$$\mathbf{v} = \omega \mathbf{e}_3 \times (x_1 \mathbf{e}_1 + x_2 \mathbf{e}_2 + x_3 \mathbf{e}_3) = \omega x_1 \mathbf{e}_2 - \omega x_2 \mathbf{e}_1, \quad (\text{ii})$$

that is,

$$v_1 = -\omega x_2, \quad v_2 = \omega x_1, \quad v_3 = 0. \quad (\text{iii})$$

In cylindrical coordinates,

$$\mathbf{v} = \omega \mathbf{e}_z \times (r \mathbf{e}_r) = r \omega \mathbf{e}_\theta, \quad (\text{iv})$$

that is,

$$v_r = 0, \quad v_\theta = \omega r, \quad v_z = 0. \quad (\text{v})$$

(b) We can use either Eq. (iii) or Eq. (v) to find the acceleration. Using Eq. (iii) and Eq. (3.4.7), we obtain

$$\begin{aligned} a_1 &= 0 + (-\omega x_2)(0) + (\omega x_1)(-\omega) + (0)(0) = -\omega^2 x_1, \\ a_2 &= 0 + (-\omega x_2)(\omega) + (\omega x_1)(0) + (0)(0) = -\omega^2 x_2, \\ a_3 &= 0, \end{aligned} \quad (\text{vi})$$

that is,

$$\mathbf{a} = -\omega^2 (x_1 \mathbf{e}_1 + x_2 \mathbf{e}_2) = -\omega^2 \mathbf{r}, \quad (\text{vii})$$

or, using Eq. (v) and Eq. (3.4.12), we obtain

$$\begin{aligned} a_r &= 0 + 0 + \frac{v_\theta}{r} (0 - v_\theta) + 0 = -\frac{(v_\theta)^2}{r} = -r\omega^2, \\ a_\theta &= 0 + 0 + \frac{v_\theta}{r} (0 + 0) + 0 = 0, \\ a_z &= 0 + 0 + \frac{v_\theta}{r} 0 + 0 = 0, \end{aligned} \quad (\text{viii})$$

that is,

$$\mathbf{a} = -r\omega^2 \mathbf{e}_r = -\omega^2 \mathbf{r}. \quad (\text{ix})$$

We note that in this example, even though at every spatial position, the velocity does not change with time, but the velocity of every particle does change with time so that it has a centripetal acceleration.

Example 3.4.2

Given the velocity field

$$v_1 = \frac{kx_1}{1+kt}, \quad v_2 = \frac{kx_2}{1+kt}, \quad v_3 = \frac{kx_3}{1+kt}.$$

(a) Find the acceleration field and (b) find the path line $\mathbf{x} = \hat{\mathbf{x}}(X, t)$.

Solution

(a) With

$$v_i = \frac{kx_i}{1+kt},$$

we have

$$a_i = \frac{\partial v_i}{\partial t} + v_j \frac{\partial v_i}{\partial x_j} = -\frac{k^2 x_i}{(1+kt)^2} + \frac{kx_j}{1+kt} \frac{k\delta_{ij}}{1+kt} = -\frac{k^2 x_i}{(1+kt)^2} + \frac{k^2 x_i}{(1+kt)^2} = 0,$$

or

$$\mathbf{a} = \mathbf{0}.$$

We note that in this example, even though at any spatial position (except the origin) the velocity is observed to be changing with time, the actual velocity of a particular particle is a constant with a zero acceleration.

(b) Since

$$v_i = \left(\frac{\partial x_i}{\partial t} \right)_{x_j \text{-fixed}} = \frac{kx_i}{1+kt},$$

therefore,

$$\int_{X_1}^{x_1} \frac{dx_1}{kx_1} = \int_0^t \frac{dt}{1+kt},$$

that is,

$$\frac{1}{k} (\ln x_1 - \ln X_1) = \frac{1}{k} \ln(1+kt),$$

or

$$x_1 = (1+kt)X_1.$$

Similarly,

$$x_2 = (1+kt)X_2,$$

$$x_3 = (1+kt)X_3.$$

These path-line equations show that each particle's displacement varies linearly with time so that its motion is acceleration-less.

3.5 DISPLACEMENT FIELD

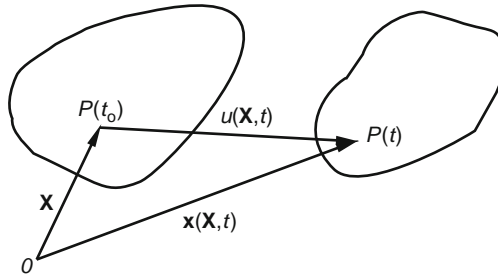

FIGURE 3.5-1

The displacement vector of a particle in a continuum (identified by its material coordinate \mathbf{X}), from the reference position $P(t_0)$, to the current position $P(t)$, is given by the vector from $P(t_0)$ to $P(t)$ (see Figure 3.5-1) and is denoted by $\mathbf{u}(\mathbf{X}, t)$. That is,

$$\mathbf{u}(\mathbf{X}, t) = \mathbf{x}(\mathbf{X}, t) - \mathbf{X}. \quad (3.5.1)$$

From the preceding equation, it is clear that whenever the path lines of a continuum are known, its displacement field is also known. Thus, the motion of a continuum can be described either by the path lines as given in Eq. (3.1.4) or by its displacement vector field as given by Eq. (3.5.1).

Example 3.5.1

The position at time t of a particle initially at (X_1, X_2, X_3) is given by

$$x_1 = X_1 + (X_1 + X_2)kt, \quad x_2 = X_2 + (X_1 + X_2)kt, \quad x_3 = X_3,$$

obtain the displacement field.

Solution

$$\begin{aligned} u_1 &= x_1 - X_1 = (X_1 + X_2)kt, \\ u_2 &= x_2 - X_2 = (X_1 + X_2)kt, \\ u_3 &= x_3 - X_3 = 0. \end{aligned}$$

Example 3.5.2

The deformed configuration of a continuum is given by

$$x_1 = \frac{1}{2}X_1, \quad x_2 = X_2, \quad x_3 = X_3,$$

obtain the displacement field.

Solution

$$u_1 = x_1 - X_1 = \frac{1}{2}X_1 - X_1 = -\frac{1}{2}X_1, \quad u_2 = x_2 - X_2 = X_2 - X_2 = 0, \quad u_3 = x_3 - X_3 = X_3 - X_3 = 0.$$

This motion represents a state of confined compression.

3.6 KINEMATIC EQUATION FOR RIGID BODY MOTION

(a) *Rigid body translation.* For this motion, the kinematic equation of motion is given by

$$\mathbf{x} = \mathbf{X} + \mathbf{c}(t), \quad (3.6.1)$$

where $\mathbf{c}(0) = \mathbf{0}$. We note that the displacement vector, $\mathbf{u} = \mathbf{x} - \mathbf{X} = \mathbf{c}(t)$, is independent of \mathbf{X} . That is, every material point is displaced in an identical manner, with the same magnitude and the same direction at time t .

(b) *Rigid body rotation about a fixed point.* For this motion, the kinematic equation of motion is given by

$$\mathbf{x} - \mathbf{b} = \mathbf{R}(t)(\mathbf{X} - \mathbf{b}), \quad (3.6.2)$$

where $\mathbf{R}(t)$ is a proper orthogonal tensor (i.e., a rotation tensor; see Section 2.15, with $\mathbf{R}(0) = \mathbf{I}$), and \mathbf{b} is a constant vector. We note when $\mathbf{X} = \mathbf{b}$, $\mathbf{x} = \mathbf{b}$ so that the material point $\mathbf{X} = \mathbf{b}$ is always at the spatial point $\mathbf{x} = \mathbf{b}$ so that the rotation is about the fixed point $\mathbf{x} = \mathbf{b}$. If the rotation is about the origin, then $\mathbf{b} = \mathbf{0}$, and

$$\mathbf{x} = \mathbf{R}(t)\mathbf{X}. \quad (3.6.3)$$

(c) *General rigid body motion.* The equation describing a general rigid body motion is given by

$$\mathbf{x} = \mathbf{R}(t)(\mathbf{X} - \mathbf{b}) + \mathbf{c}(t), \quad (3.6.4)$$

where $\mathbf{R}(t)$ is a rotation tensor with $\mathbf{R}(0) = \mathbf{I}$ and $\mathbf{c}(t)$ is a vector with $\mathbf{c}(0) = \mathbf{b}$. Equation (3.6.4) states that the motion is described by a translation $\mathbf{c}(t)$ of an arbitrary chosen material base point $\mathbf{X} = \mathbf{b}$ plus a rotation $\mathbf{R}(t)$ about the base point.

Example 3.6.1

Show that for the motion given by (3.6.2) there is no change in the distance between any pair of material points.

Solution

Consider two material points $\mathbf{X}^{(1)}$ and $\mathbf{X}^{(2)}$ in the body; we have, from Eq. (3.6.2),

$$\begin{aligned} \mathbf{x}^{(1)} - \mathbf{b} &= \mathbf{R}(t)(\mathbf{X}^{(1)} - \mathbf{b}), \\ \mathbf{x}^{(2)} - \mathbf{b} &= \mathbf{R}(t)(\mathbf{X}^{(2)} - \mathbf{b}), \end{aligned}$$

so that

$$\mathbf{x}^{(1)} - \mathbf{x}^{(2)} = \mathbf{R}(t)(\mathbf{X}^{(1)} - \mathbf{X}^{(2)}).$$

That is, due to the motion, the material vector $\Delta \mathbf{x} \equiv \mathbf{x}^{(1)} - \mathbf{x}^{(2)}$ changes to $\Delta \mathbf{x} \equiv \mathbf{x}^{(1)} - \mathbf{x}^{(2)}$ with

$$\Delta \mathbf{x} = \mathbf{R}(t)\Delta \mathbf{X}.$$

Let $\Delta \ell$ and ΔL be the length of $\Delta \mathbf{x}$ and $\Delta \mathbf{X}$, respectively, we have

$$(\Delta \ell)^2 = \Delta \mathbf{x} \cdot \Delta \mathbf{x} = (\mathbf{R}(t)\Delta \mathbf{X}) \cdot (\mathbf{R}(t)\Delta \mathbf{X}).$$

Using the definition of transpose and the fact that $\mathbf{R}^T \mathbf{R} = \mathbf{I}$, the right side of the preceding equation becomes

$$(\mathbf{R}(t)\Delta \mathbf{X}) \cdot (\mathbf{R}(t)\Delta \mathbf{X}) = \Delta \mathbf{X} \cdot \mathbf{R}^T \mathbf{R} \Delta \mathbf{X} = \Delta \mathbf{X} \cdot \mathbf{I} \Delta \mathbf{X} = \Delta \mathbf{X} \cdot \Delta \mathbf{X}.$$

Thus,

$$(\Delta \ell)^2 = (\Delta L)^2,$$

that is, $\Delta \ell = \Delta L$.

Example 3.6.2

From Eq. (3.6.4), derive the relation between the velocity of a general material point in the rigid body with the angular velocity of the body and the velocity of the arbitrary chosen material point.

Solution

Taking the material derivative of Eq. (3.6.4), we obtain

$$\mathbf{v} = \dot{\mathbf{R}}(\mathbf{X} - \mathbf{b}) + \dot{\mathbf{c}}(t).$$

Here we have used a super dot to denote a material derivative. Now, from Eq. (3.6.4) again, we have

$$(\mathbf{X} - \mathbf{b}) = \mathbf{R}^T(\mathbf{x} - \mathbf{c}).$$

Thus,

$$\mathbf{v} = \dot{\mathbf{R}}\mathbf{R}^T(\mathbf{x} - \mathbf{c}) + \dot{\mathbf{c}}(t).$$

Now, by taking the time derivative of the equation $\mathbf{R}\mathbf{R}^T = \mathbf{I}$, we have

$$\dot{\mathbf{R}}\mathbf{R}^T + \mathbf{R}\dot{\mathbf{R}}^T = \mathbf{0}.$$

As a consequence,

$$\dot{\mathbf{R}}\mathbf{R}^T = -\mathbf{R}\dot{\mathbf{R}}^T = -(\dot{\mathbf{R}}\mathbf{R}^T)^T.$$

That is, $\dot{\mathbf{R}}\mathbf{R}^T$ is an antisymmetric tensor, which is equivalent to a dual vector $\boldsymbol{\omega}$ such that $(\dot{\mathbf{R}}\mathbf{R}^T)\mathbf{a} = \boldsymbol{\omega} \times \mathbf{a}$ for any vector \mathbf{a} (see Section 2.21). Thus,

$$\mathbf{v} = \boldsymbol{\omega} \times (\mathbf{x} - \mathbf{c}) + \dot{\mathbf{c}}(t).$$

If for a general material point, we measure its position vector \mathbf{r} from the position at time t of the chosen material base point, i.e., $\mathbf{r} = \mathbf{x} - \mathbf{c}$, then we obtain the well-known equation below:

$$\mathbf{v} = \boldsymbol{\omega} \times \mathbf{r} + \dot{\mathbf{c}}(t).$$

3.7 INFINITESIMAL DEFORMATION

There are many important engineering problems that involve structural members or machine parts for which the deformation is very small (mathematically treated as infinitesimal). In this section, we derive the tensor that characterizes the deformation of such bodies.

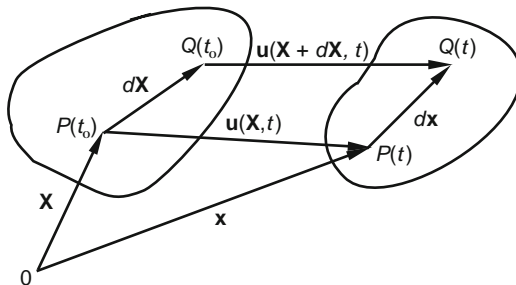

FIGURE 3.7-1

Consider a body having a particular configuration at some reference time t_0 , changes to another configuration at time t . Referring to Figure 3.7-1, a typical material point P undergoes a displacement \mathbf{u} so that it arrives at the position

$$\mathbf{x} = \mathbf{X} + \mathbf{u}(\mathbf{X}, t). \quad (3.7.1)$$

A neighboring point Q at $\mathbf{X} + d\mathbf{X}$ arrives at $\mathbf{x} + d\mathbf{x}$, which is related to $\mathbf{X} + d\mathbf{X}$ by

$$\mathbf{x} + d\mathbf{x} = \mathbf{X} + d\mathbf{X} + \mathbf{u}(\mathbf{X} + d\mathbf{X}, t). \quad (3.7.2)$$

Subtracting Eq. (3.7.1) from Eq. (3.7.2), we obtain

$$d\mathbf{x} = d\mathbf{X} + \mathbf{u}(\mathbf{X} + d\mathbf{X}, t) - \mathbf{u}(\mathbf{X}, t). \quad (3.7.3)$$

Using the definition of gradient of a vector function [see Eq. (2.28.1)], Eq. (3.7.3) becomes

$$d\mathbf{x} = d\mathbf{X} + (\nabla \mathbf{u})d\mathbf{X}, \quad (3.7.4)$$

where $\nabla \mathbf{u}$ is a second-order tensor known as the *displacement gradient*. The matrix of $\nabla \mathbf{u}$ with respect to rectangular Cartesian coordinates ($\mathbf{X} = X_i \mathbf{e}_i$ and $\mathbf{u} = u_i \mathbf{e}_i$) is

$$[\nabla \mathbf{u}] = \begin{bmatrix} \frac{\partial u_1}{\partial X_1} & \frac{\partial u_1}{\partial X_2} & \frac{\partial u_1}{\partial X_3} \\ \frac{\partial u_2}{\partial X_1} & \frac{\partial u_2}{\partial X_2} & \frac{\partial u_2}{\partial X_3} \\ \frac{\partial u_3}{\partial X_1} & \frac{\partial u_3}{\partial X_2} & \frac{\partial u_3}{\partial X_3} \end{bmatrix}. \quad (3.7.5)$$

Example 3.7.1

Given the following displacement components

$$u_1 = kX_2^2, \quad u_2 = u_3 = 0. \quad (i)$$

- (a) Sketch the deformed shape of the unit square $OABC$ shown in Figure 3.7-2.
 (b) Find the deformed vectors (i.e., $d\mathbf{x}^{(1)}$ and $d\mathbf{x}^{(2)}$) of the material elements $d\mathbf{X}^{(1)} = dX_1\mathbf{e}_1$ and $d\mathbf{X}^{(2)} = dX_2\mathbf{e}_2$, which were at the point C .
 (c) Determine the ratio of the deformed to the undeformed lengths of the differential elements (known as *stretch*) of part (b) and the change in angle between these elements.

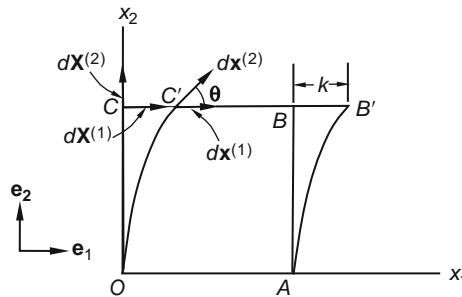

FIGURE 3.7-2

Solution

- (a) For the material line OA , $X_2 = 0$, therefore, from Eq. (i), $u_1 = u_2 = u_3 = 0$. That is, the line is not displaced. For the material line CB , $X_2 = 1$, $u_1 = k$, $u_2 = u_3 = 0$, the line is displaced by k units to the right. For the material line OC and AB , $u_1 = kX_2^2$, $u_2 = u_3 = 0$, each line becomes parabolic in shape. Thus, the deformed shape is given by $OAB'C'$ shown in Figure 3.7-2.
 (b) For the material point C , the matrix of the displacement gradient is

$$[\nabla\mathbf{u}] = \begin{bmatrix} 0 & 2kX_2 & 0 \\ 0 & 0 & 0 \\ 0 & 0 & 0 \end{bmatrix}_{X_2=1} = \begin{bmatrix} 0 & 2k & 0 \\ 0 & 0 & 0 \\ 0 & 0 & 0 \end{bmatrix}. \quad (ii)$$

Therefore, for $d\mathbf{X}^{(1)} = dX_1\mathbf{e}_1$, from Eq. (3.7.4), we have

$$d\mathbf{x}^{(1)} = d\mathbf{X}^{(1)} + (\nabla\mathbf{u})d\mathbf{X}^{(1)} = dX_1\mathbf{e}_1 + 0 = dX_1\mathbf{e}_1, \quad (iii)$$

and for $d\mathbf{X}^{(2)} = dX_2\mathbf{e}_2$,

$$d\mathbf{x}^{(2)} = d\mathbf{X}^{(2)} + (\nabla\mathbf{u})d\mathbf{X}^{(2)} = dX_2\mathbf{e}_2 + 2kdX_2\mathbf{e}_1 = dX_2(2k\mathbf{e}_1 + \mathbf{e}_2). \quad (iv)$$

- (c) From Eqs. (iii) and (iv), we have

$$|d\mathbf{x}^{(1)}| = dX_1 \quad \text{and} \quad |d\mathbf{x}^{(2)}| = dX_2\sqrt{4k^2 + 1},$$

therefore,

$$\frac{|d\mathbf{x}^{(1)}|}{|d\mathbf{X}^{(1)}|} = 1 \quad \text{and} \quad \frac{|d\mathbf{x}^{(2)}|}{|d\mathbf{X}^{(2)}|} = \sqrt{4k^2 + 1}, \quad (\text{v})$$

and

$$\cos \theta = \frac{d\mathbf{x}^{(1)} \cdot d\mathbf{x}^{(2)}}{|d\mathbf{x}^{(1)}| |d\mathbf{x}^{(2)}|} = \frac{2k}{\sqrt{1 + 4k^2}}. \quad (\text{vi})$$

If k is very small, we have the case of small deformations, and by the binomial theorem, we have, from Eq. (v), keeping only the first power of k ,

$$\frac{|d\mathbf{x}^{(1)}|}{|d\mathbf{X}^{(1)}|} = 1 \quad \text{and} \quad \frac{|d\mathbf{x}^{(2)}|}{|d\mathbf{X}^{(2)}|} = \sqrt{4k^2 + 1} \approx 1 + 2k^2 \approx 1,$$

and from Eq. (vi),

$$\cos \theta \approx 2k.$$

If γ denotes the decrease in angle, then

$$\cos \theta = \cos\left(\frac{\pi}{2} - \gamma\right) = \sin \gamma = 2k.$$

Now, for very small k , γ is also small, so that $\sin \gamma \approx \gamma$ and we have

$$\gamma \approx 2k.$$

We can write Eq. (3.7.4), i.e., $d\mathbf{x} = d\mathbf{X} + (\nabla\mathbf{u})d\mathbf{X}$ as

$$d\mathbf{x} = \mathbf{F}d\mathbf{X}, \quad (3.7.6)$$

where

$$\mathbf{F} = \mathbf{I} + \nabla\mathbf{u}. \quad (3.7.7)$$

Here \mathbf{F} is known as the *deformation gradient* because it is the gradient of the function $\hat{\mathbf{x}}(X, t)$ describing the motion, i.e., $\mathbf{x} = \hat{\mathbf{x}}(X, t)$.

To find the relationship between ds (the length of $d\mathbf{x}$) and dS (the length of $d\mathbf{X}$), we take the dot product of Eq. (3.7.6) with itself:

$$d\mathbf{x} \cdot d\mathbf{x} = \mathbf{F}d\mathbf{X} \cdot \mathbf{F}d\mathbf{X} = d\mathbf{X} \cdot (\mathbf{F}^T\mathbf{F})d\mathbf{X}, \quad (3.7.8)$$

that is,

$$ds^2 = d\mathbf{X} \cdot \mathbf{C}d\mathbf{X}, \quad (3.7.9)$$

where

$$\mathbf{C} = \mathbf{F}^T\mathbf{F}. \quad (3.7.10)$$

The tensor \mathbf{C} is known as the *right Cauchy-Green deformation tensor*. We note that if $\mathbf{C} = \mathbf{I}$, then $ds^2 = dS^2$. Therefore, $\mathbf{C} = \mathbf{I}$ corresponds to a rigid body motion (translation and/or rotation). From Eq. (3.7.7), we have

$$\mathbf{C} = \mathbf{F}^T\mathbf{F} = (\mathbf{I} + \nabla\mathbf{u})^T(\mathbf{I} + \nabla\mathbf{u}) = \mathbf{I} + \nabla\mathbf{u} + (\nabla\mathbf{u})^T + (\nabla\mathbf{u})^T(\nabla\mathbf{u}). \quad (3.7.11)$$

Let

$$\mathbf{E}^* = \frac{1}{2} [\nabla \mathbf{u} + (\nabla \mathbf{u})^T + (\nabla \mathbf{u})^T (\nabla \mathbf{u})], \quad (3.7.12)$$

then Eq. (3.7.11) becomes

$$\mathbf{C} = \mathbf{I} + 2\mathbf{E}^*. \quad (3.7.13)$$

Since $\mathbf{C} = \mathbf{I}$ corresponds to a rigid body motion, Eq. (3.7.13) clearly shows that the tensor \mathbf{E}^* characterizes the changes of lengths in the continuum due to displacements of the material points. This tensor \mathbf{E}^* is known as the *Lagrange strain tensor*. It is a finite deformation tensor.

In this section, we consider only cases where the components of the displacement vector as well as their partial derivatives are all very small (mathematically infinitesimal) so that the absolute value of every component of $(\nabla \mathbf{u})^T (\nabla \mathbf{u})$ is a small quantity of higher order than those of the components of $(\nabla \mathbf{u})$. For such cases

$$\mathbf{C} \approx \mathbf{I} + 2\mathbf{E}, \quad (3.7.14)$$

where

$$\mathbf{E} = \frac{1}{2} [\nabla \mathbf{u} + (\nabla \mathbf{u})^T] = \text{symmetric part of } (\nabla \mathbf{u}). \quad (3.7.15)$$

This tensor \mathbf{E} is known as the *infinitesimal strain tensor*. In Cartesian coordinates

$$E_{ij} = \frac{1}{2} \left(\frac{\partial u_i}{\partial X_j} + \frac{\partial u_j}{\partial X_i} \right). \quad (3.7.16)$$

Consider two material elements $d\mathbf{X}^{(1)}$ and $d\mathbf{X}^{(2)}$. Due to motion, they become $d\mathbf{x}^{(1)}$ and $d\mathbf{x}^{(2)}$ at time t . We have, for small deformation, from Eq. (3.7.6) and Eq. (3.7.14),

$$d\mathbf{x}^{(1)} \cdot d\mathbf{x}^{(2)} = \mathbf{F}d\mathbf{X}^{(1)} \cdot \mathbf{F}d\mathbf{X}^{(2)} = d\mathbf{X}^{(1)} \cdot \mathbf{C}d\mathbf{X}^{(2)} = d\mathbf{X}^{(1)} \cdot (\mathbf{I} + 2\mathbf{E})d\mathbf{X}^{(2)}, \quad (3.7.17)$$

that is,

$$d\mathbf{x}^{(1)} \cdot d\mathbf{x}^{(2)} = d\mathbf{X}^{(1)} \cdot d\mathbf{X}^{(2)} + 2d\mathbf{X}^{(1)} \cdot \mathbf{E}d\mathbf{X}^{(2)}. \quad (3.7.18)$$

This equation will be used in the next section to establish the meaning of the components of the infinitesimal strain tensor \mathbf{E} .

Using the expressions derived in Parts C and D of Chapter 2, we can obtain the matrices of infinitesimal strain tensor \mathbf{E} in terms of the components of the displacement gradients in rectangular coordinates, cylindrical coordinates, and spherical coordinates.

(a) Rectangular coordinates:

$$[\mathbf{E}] = \begin{bmatrix} \frac{\partial u_1}{\partial X_1} & \frac{1}{2} \left(\frac{\partial u_1}{\partial X_2} + \frac{\partial u_2}{\partial X_1} \right) & \frac{1}{2} \left(\frac{\partial u_1}{\partial X_3} + \frac{\partial u_3}{\partial X_1} \right) \\ \frac{1}{2} \left(\frac{\partial u_1}{\partial X_2} + \frac{\partial u_2}{\partial X_1} \right) & \frac{\partial u_2}{\partial X_2} & \frac{1}{2} \left(\frac{\partial u_2}{\partial X_3} + \frac{\partial u_3}{\partial X_2} \right) \\ \frac{1}{2} \left(\frac{\partial u_1}{\partial X_3} + \frac{\partial u_3}{\partial X_1} \right) & \frac{1}{2} \left(\frac{\partial u_2}{\partial X_3} + \frac{\partial u_3}{\partial X_2} \right) & \frac{\partial u_3}{\partial X_3} \end{bmatrix}. \quad (3.7.19)$$

(b) Cylindrical coordinates:

$$[\mathbf{E}] = \begin{bmatrix} \frac{\partial u_r}{\partial r} & \frac{1}{2} \left(\frac{1}{r} \frac{\partial u_r}{\partial \theta} - \frac{u_\theta}{r} + \frac{\partial u_\theta}{\partial r} \right) & \frac{1}{2} \left(\frac{\partial u_r}{\partial z} + \frac{\partial u_z}{\partial r} \right) \\ \frac{1}{2} \left(\frac{1}{r} \frac{\partial u_r}{\partial \theta} - \frac{u_\theta}{r} + \frac{\partial u_\theta}{\partial r} \right) & \frac{1}{r} \frac{\partial u_\theta}{\partial \theta} + \frac{u_r}{r} & \frac{1}{2} \left(\frac{\partial u_\theta}{\partial z} + \frac{1}{r} \frac{\partial u_z}{\partial \theta} \right) \\ \frac{1}{2} \left(\frac{\partial u_r}{\partial z} + \frac{\partial u_z}{\partial r} \right) & \frac{1}{2} \left(\frac{\partial u_\theta}{\partial z} + \frac{1}{r} \frac{\partial u_z}{\partial \theta} \right) & \frac{\partial u_z}{\partial z} \end{bmatrix}. \quad (3.7.20)$$

(c) Spherical coordinates:

$$[\mathbf{E}] = \begin{bmatrix} \frac{\partial u_r}{\partial r} & \frac{1}{2} \left(\frac{1}{r} \frac{\partial u_r}{\partial \theta} - \frac{u_\theta}{r} + \frac{\partial u_\theta}{\partial r} \right) & \frac{1}{2} \left(\frac{1}{r \sin \theta} \frac{\partial u_r}{\partial \phi} - \frac{u_\phi}{r} + \frac{\partial u_\phi}{\partial r} \right) \\ E_{21} = E_{12} & \frac{1}{r} \frac{\partial u_\theta}{\partial \theta} + \frac{u_r}{r} & \frac{1}{2} \left(\frac{1}{r \sin \theta} \frac{\partial u_\theta}{\partial \phi} - \frac{u_\phi \cot \theta}{r} + \frac{1}{r} \frac{\partial u_\phi}{\partial \theta} \right) \\ E_{31} = E_{13} & E_{32} = E_{23} & \frac{1}{r \sin \theta} \frac{\partial u_\phi}{\partial \phi} + \frac{u_r}{r} + \frac{u_\theta \cot \theta}{r} \end{bmatrix}. \quad (3.7.21)$$

3.8 GEOMETRICAL MEANING OF THE COMPONENTS OF THE INFINITESIMAL STRAIN TENSOR

(a) *Diagonal elements of E.* Consider the single material element $d\mathbf{X}^{(1)} = d\mathbf{X}^{(2)} = d\mathbf{X} = dS\mathbf{n}$, where \mathbf{n} is a unit vector and dS is the length of $d\mathbf{X}$. Due to motion, $d\mathbf{X}$ becomes $d\mathbf{x}$ with a length of ds . Eq. (3.7.18) gives $d\mathbf{x} \cdot d\mathbf{x} = d\mathbf{X} \cdot d\mathbf{X} + 2dS\mathbf{n} \cdot \mathbf{E}dS\mathbf{n}$. That is,

$$ds^2 = dS^2 + 2dS^2(\mathbf{n} \cdot \mathbf{E}\mathbf{n}). \quad (3.8.1)$$

For small deformation, $ds^2 - dS^2 = (ds - dS)(ds + dS) \approx 2dS(ds - dS)$. Thus, Eq. (3.8.1) gives:

$$\frac{ds - dS}{dS} = \mathbf{n} \cdot \mathbf{E}\mathbf{n} = E_{nn} \text{ (no sum on } n\text{)}. \quad (3.8.2)$$

This equation states that the unit elongation (i.e., increase in length per unit original length) for the element that was in the direction \mathbf{n} , is given by $\mathbf{n} \cdot \mathbf{E}\mathbf{n}$. In particular, if the element was in the \mathbf{e}_1 direction in the reference state, then $\mathbf{n} = \mathbf{e}_1$ and $\mathbf{e}_1 \cdot \mathbf{E}\mathbf{e}_1 = E_{11}$, etc. Thus,

E_{11} is the unit elongation for an element originally in the x_1 direction.

E_{22} is the unit elongation for an element originally in the x_2 direction.

E_{33} is the unit elongation for an element originally in the x_3 direction.

These components (the diagonal elements of \mathbf{E}) are also known as the *normal strains*.

- (b) *The off diagonal elements of \mathbf{E} .* Let $d\mathbf{X}^{(1)} = dS_1\mathbf{m}$ and $d\mathbf{X}^{(2)} = dS_2\mathbf{n}$, where \mathbf{m} and \mathbf{n} are unit vectors perpendicular to each other. Due to motion, $d\mathbf{X}^{(1)}$ becomes $d\mathbf{x}^{(1)}$ with length ds_1 and $d\mathbf{X}^{(2)}$ becomes $d\mathbf{x}^{(2)}$ with length ds_2 . Let the angle between the two deformed vectors $d\mathbf{x}^{(1)}$ and $d\mathbf{x}^{(2)}$ be denoted by θ . Then Eq. (3.7.18) gives

$$ds_1 ds_2 \cos \theta = 2dS_1 dS_2 \mathbf{m} \cdot \mathbf{E} \mathbf{n}. \quad (3.8.3)$$

If we let

$$\theta = \frac{\pi}{2} - \gamma, \quad (3.8.4)$$

then γ measures the small decrease in angle between $d\mathbf{X}^{(1)}$ and $d\mathbf{X}^{(2)}$ (known as the *shear strain*) due to deformation. Since

$$\cos\left(\frac{\pi}{2} - \gamma\right) = \sin \gamma, \quad (3.8.5)$$

and for small strain

$$\sin \gamma \approx \gamma, \quad \frac{ds_1}{dS_1} \approx 1, \quad \frac{ds_2}{dS_2} \approx 1, \quad (3.8.6)$$

therefore, Eq. (3.8.3) becomes

$$\gamma = 2(\mathbf{m} \cdot \mathbf{E} \mathbf{n}). \quad (3.8.7)$$

In particular, if the elements were in the \mathbf{e}_1 and \mathbf{e}_2 directions before deformation, then $\mathbf{m} \cdot \mathbf{E} \mathbf{n} = \mathbf{e}_1 \cdot \mathbf{E} \mathbf{e}_2 = E_{12}$, etc., so that, according to Eq. (3.8.7):

$2E_{12}$ gives the decrease in angle between two elements initially in the x_1 and x_2 directions.

$2E_{13}$ gives the decrease in angle between two elements initially in the x_1 and x_3 directions.

$2E_{23}$ gives the decrease in angle between two elements initially in the x_2 and x_3 directions.

Example 3.8.1

Given the displacement components

$$u_1 = kX_2^2, \quad u_2 = u_3 = 0, \quad k = 10^{-4}, \quad (i)$$

- (a) Obtain the infinitesimal strain tensor \mathbf{E} .
 (b) Using the strain tensor \mathbf{E} , find the unit elongation for the material elements $d\mathbf{X}^{(1)} = dX_1\mathbf{e}_1$ and $d\mathbf{X}^{(2)} = dX_2\mathbf{e}_2$, which were at the point $C(0, 1, 0)$ of Figure 3.8-1. Also find the decrease in angle between these two elements.
 (c) Compare the results with those of Example 3.7.1.

Solution

- (a) We have

$$[\nabla \mathbf{u}] = \begin{bmatrix} 0 & 2kX_2 & 0 \\ 0 & 0 & 0 \\ 0 & 0 & 0 \end{bmatrix}, \quad (ii)$$

therefore,

$$[\mathbf{E}] = [(\nabla \mathbf{u})^S] = \begin{bmatrix} 0 & kX_2 & 0 \\ kX_2 & 0 & 0 \\ 0 & 0 & 0 \end{bmatrix}. \quad (\text{iii})$$

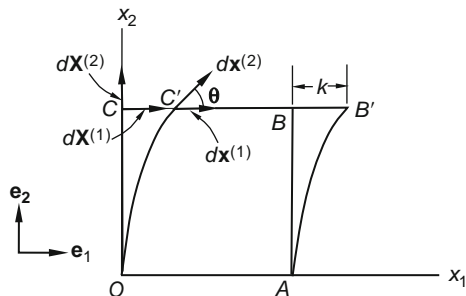

FIGURE 3.8-1

(b) At point C, $X_2 = 1$, therefore,

$$[\mathbf{E}] = [\nabla \mathbf{u}]^S = \begin{bmatrix} 0 & k & 0 \\ k & 0 & 0 \\ 0 & 0 & 0 \end{bmatrix}. \quad (\text{iv})$$

For the element $d\mathbf{X}^{(1)} = dX_1 \mathbf{e}_1$, the unit elongation is E_{11} , which is zero. For the element $d\mathbf{X}^{(2)} = dX_2 \mathbf{e}_2$, the unit elongation is E_{22} , which is also zero. The decrease in angle between these elements is given by $2E_{12}$, which is equal to $2k$, i.e., 2×10^{-4} radians.

(c) In Example 3.7.1, we found that

$$\frac{|d\mathbf{x}^{(1)}|}{|d\mathbf{X}^{(1)}|} = 1, \quad \frac{|d\mathbf{x}^{(2)}|}{|d\mathbf{X}^{(2)}|} = \sqrt{4k^2 + 1} \quad \text{and} \quad \sin \gamma = 2k, \quad (\text{v})$$

i.e.,

$$\frac{|d\mathbf{x}^{(1)}| - |d\mathbf{X}^{(1)}|}{|d\mathbf{X}^{(1)}|} = 0 \quad \text{and} \quad \frac{|d\mathbf{x}^{(2)}| - |d\mathbf{X}^{(2)}|}{|d\mathbf{X}^{(2)}|} = \sqrt{4k^2 + 1} - 1 \approx 1 + 2k^2 - 1 = 2k^2 \approx 0,$$

and $\gamma \approx 2 \times 10^{-4}$.

Comparing the results of part (b) with part (c), we see that the result of part (b), where infinitesimal strain tensor was used, is accurate up to the order of k .

Example 3.8.2

Given the displacement field

$$u_1 = k(2X_1 + X_2^2), \quad u_2 = k(X_1^2 - X_2^2), \quad u_3 = 0, \quad k = 10^{-4}. \quad (\text{i})$$

- (a) Find the unit elongation and the change of angle for the two material elements $d\mathbf{X}^{(1)} = dX_1\mathbf{e}_1$ and $d\mathbf{X}^{(2)} = dX_2\mathbf{e}_2$ that emanate from a particle designated by $\mathbf{X} = \mathbf{e}_1 - \mathbf{e}_2$.
- (b) Find the deformed position of these two elements: $d\mathbf{X}^{(1)}$ and $d\mathbf{X}^{(2)}$.

Solution

- (a) We evaluate $[\nabla\mathbf{u}]$ and $[\mathbf{E}]$ at $(X_1, X_2, X_3) = (1, -1, 0)$ as

$$[\nabla\mathbf{u}] = k \begin{bmatrix} 2 & -2 & 0 \\ 2 & 2 & 0 \\ 0 & 0 & 0 \end{bmatrix}, \quad [\mathbf{E}] = [\nabla\mathbf{u}]^S = k \begin{bmatrix} 2 & 0 & 0 \\ 0 & 2 & 0 \\ 0 & 0 & 0 \end{bmatrix}. \quad (ii)$$

Since $E_{11} = E_{22} = 2k$, both elements have a unit elongation of 2×10^{-4} . Further, since $E_{12} = 0$, these line elements remain perpendicular to each other.

- (b) From Eq. (3.7.4),

$$[d\mathbf{x}^{(1)}] = [d\mathbf{X}^{(1)}] + [\nabla\mathbf{u}][d\mathbf{X}^{(1)}] = \begin{bmatrix} dX_1 \\ 0 \\ 0 \end{bmatrix} + k \begin{bmatrix} 2 & -2 & 0 \\ 2 & 2 & 0 \\ 0 & 0 & 0 \end{bmatrix} \begin{bmatrix} dX_1 \\ 0 \\ 0 \end{bmatrix} = dX_1 \begin{bmatrix} 1 + 2k \\ 2k \\ 0 \end{bmatrix}, \quad (iii)$$

and

$$[d\mathbf{x}^{(2)}] = [d\mathbf{X}^{(2)}] + [\nabla\mathbf{u}][d\mathbf{X}^{(2)}] = \begin{bmatrix} 0 \\ dX_2 \\ 0 \end{bmatrix} + k \begin{bmatrix} 2 & -2 & 0 \\ 2 & 2 & 0 \\ 0 & 0 & 0 \end{bmatrix} \begin{bmatrix} 0 \\ dX_2 \\ 0 \end{bmatrix} = dX_2 \begin{bmatrix} -2k \\ 1 + 2k \\ 0 \end{bmatrix}. \quad (iv)$$

The deformed positions of these elements are sketched in Figure 3.8-2. Note from the diagram that

$$\alpha \approx \tan \alpha = \frac{2kdX_1}{dX_1(1 + 2k)} = \frac{2k}{(1 + 2k)} \approx 2k, \quad (v)$$

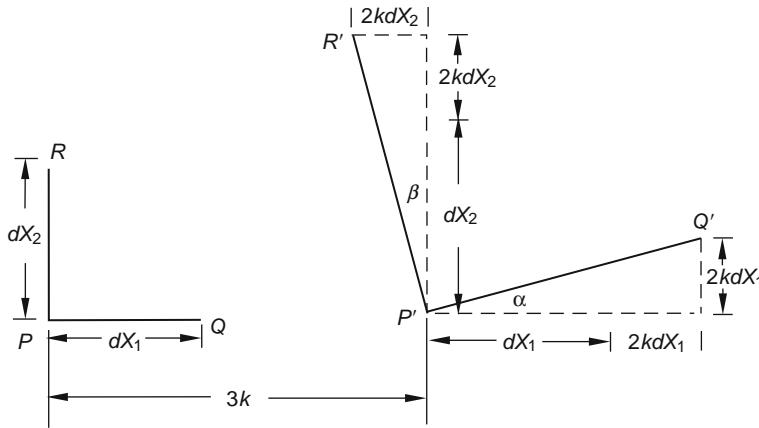

FIGURE 3.8-2

and

$$\beta \approx \tan \beta = \frac{2k dX_2}{dX_2(1+2k)} \approx 2k. \quad (\text{vi})$$

Thus, as previously obtained, there is no change of angle between $d\mathbf{X}^{(1)}$ and $d\mathbf{X}^{(2)}$.

Example 3.8.3

A unit cube with edges parallel to the coordinate axes is given a displacement field

$$u_1 = kX_1, \quad u_2 = u_3 = 0, \quad k = 10^{-4}. \quad (\text{i})$$

Find the increase in length of the diagonal AB (see Figure 3.8-3) (a) by using the infinitesimal strain tensor \mathbf{E} and (b) by geometry.

Solution

(a) We have

$$[\mathbf{E}] = \begin{bmatrix} k & 0 & 0 \\ 0 & 0 & 0 \\ 0 & 0 & 0 \end{bmatrix}. \quad (\text{ii})$$

Since the diagonal element was originally in the direction $\mathbf{n} = \frac{\sqrt{2}}{2}(\mathbf{e}_1 + \mathbf{e}_2)$, its unit elongation is given by

$$E_{nn} = \mathbf{n} \cdot \mathbf{E} \mathbf{n} = \begin{bmatrix} \sqrt{2}/2 & \sqrt{2}/2 & 0 \end{bmatrix} \begin{bmatrix} k & 0 & 0 \\ 0 & 0 & 0 \\ 0 & 0 & 0 \end{bmatrix} \begin{bmatrix} \sqrt{2}/2 \\ \sqrt{2}/2 \\ 0 \end{bmatrix} = \frac{k}{2} \text{ (no sum on } n\text{)}. \quad (\text{iii})$$

Since $AB = \sqrt{2}$,

$$\Delta AB = \frac{k}{2} \sqrt{2}. \quad (\text{iv})$$

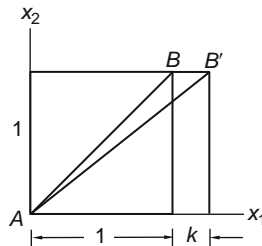

FIGURE 3.8-3

(b) Geometrically,

$$\Delta AB = AB' - AB = \left[1 + (1 + k)^2\right]^{1/2} - \sqrt{2} = \sqrt{2} \left[1 + k + (k^2/2)\right]^{1/2} - \sqrt{2}. \quad (v)$$

Now,

$$\left[1 + k + k^2/2\right]^{1/2} = 1 + \frac{1}{2} \left(k + \frac{k^2}{2}\right) + \dots \approx 1 + \frac{1}{2}k. \quad (vi)$$

Therefore, in agreement with part (a),

$$\Delta AB = \frac{k}{2} \sqrt{2}. \quad (vii)$$

3.9 PRINCIPAL STRAIN

Since the strain tensor \mathbf{E} is symmetric, there exist at least three mutually perpendicular directions ($\mathbf{n}_1, \mathbf{n}_2, \mathbf{n}_3$) with respect to which the matrix of \mathbf{E} is diagonal (see Section 2.23). That is,

$$[\mathbf{E}]_{\mathbf{n}_i} = \begin{bmatrix} E_1 & 0 & 0 \\ 0 & E_2 & 0 \\ 0 & 0 & E_3 \end{bmatrix}. \quad (3.9.1)$$

Geometrically, this means that infinitesimal line elements in the directions of ($\mathbf{n}_1, \mathbf{n}_2, \mathbf{n}_3$) remain mutually perpendicular after deformation. These directions are known as *principal directions*. The unit elongations along the principal directions (i.e., E_1, E_2, E_3) are the eigenvalues of \mathbf{E} , or *principal strains*. They include the maximum and the minimum normal strains among all directions emanating from the particle. For a given \mathbf{E} , the principal strains are to be found from the characteristic equation of \mathbf{E} , i.e.,

$$\lambda^3 - I_1 \lambda^2 + I_2 \lambda - I_3 = 0, \quad (3.9.2)$$

where

$$I_1 = E_{11} + E_{22} + E_{33}, \quad (3.9.3)$$

$$I_2 = \begin{vmatrix} E_{11} & E_{12} \\ E_{21} & E_{22} \end{vmatrix} + \begin{vmatrix} E_{22} & E_{23} \\ E_{32} & E_{33} \end{vmatrix} + \begin{vmatrix} E_{11} & E_{13} \\ E_{31} & E_{33} \end{vmatrix}, \quad (3.9.4)$$

$$I_3 = |\mathbf{E}_{ij}|. \quad (3.9.5)$$

The coefficients I_1, I_2 and I_3 are called the *principal scalar invariants* of the strain tensor.

3.10 DILATATION

The first scalar invariant of the infinitesimal strain tensor has a simple geometric meaning. For a specific deformation, consider the three material lines that emanate from a single point P and are in the principal directions. These lines define a rectangular parallelepiped whose sides have been elongated from the initial

lengths dS_1 , dS_2 , and dS_3 to $dS_1(1 + E_1)$, $dS_2(1 + E_2)$, and $dS_3(1 + E_3)$, where E_1 , E_2 , and E_3 are the principal strains. The change $\Delta(dV)$ in this material volume dV is

$$\begin{aligned}\Delta(dV) &= dS_1 dS_2 dS_3 (1 + E_1)(1 + E_2)(1 + E_3) - dS_1 dS_2 dS_3 \\ &= dS_1 dS_2 dS_3 (E_1 + E_2 + E_3) + \text{higher order terms in } E_i.\end{aligned}\quad (3.10.1)$$

For small deformation

$$e \equiv \frac{\Delta(dV)}{dV} = E_1 + E_2 + E_3 = \text{the first principal scalar invariant.} \quad (3.10.2)$$

Thus, in general,

$$e = E_{ii} = \frac{\partial u_i}{\partial X_i} = \text{div } \mathbf{u}. \quad (3.10.3)$$

This unit volume change is known as *dilatation*. In terms of displacements, we have:

In rectangular Cartesian coordinates:

$$e = \frac{\partial u_1}{\partial x_1} + \frac{\partial u_2}{\partial x_2} + \frac{\partial u_3}{\partial x_3}. \quad (3.10.4)$$

In cylindrical coordinates:

$$e = \frac{\partial u_r}{\partial r} + \frac{1}{r} \left(\frac{\partial u_\theta}{\partial \theta} + u_r \right) + \frac{\partial u_z}{\partial z}. \quad (3.10.5)$$

In spherical coordinates:

$$e = \frac{\partial u_r}{\partial r} + \frac{1}{r} \frac{\partial u_\theta}{\partial \theta} + \frac{2u_r}{r} + \frac{1}{r \sin \theta} \frac{\partial u_\phi}{\partial \phi} + \frac{u_\theta \cot \theta}{r}. \quad (3.10.6)$$

3.11 THE INFINITESIMAL ROTATION TENSOR

Decomposing $\nabla \mathbf{u}$ into a symmetric part \mathbf{E} and an antisymmetric part $\mathbf{\Omega}$, Eq. (3.7.4) can be written as

$$d\mathbf{x} = d\mathbf{X} + (\nabla \mathbf{u})d\mathbf{X} = d\mathbf{X} + (\mathbf{E} + \mathbf{\Omega})d\mathbf{X}, \quad (3.11.1)$$

where $\mathbf{\Omega} = (\nabla \mathbf{u})^A$, the antisymmetric part of $\nabla \mathbf{u}$, is known as the *infinitesimal rotation tensor*. We see that the change of direction of $d\mathbf{X}$ in general comes from two sources, the infinitesimal deformation tensor \mathbf{E} and the infinitesimal rotation tensor $\mathbf{\Omega}$. However, for any $d\mathbf{X}$ that is in the direction of an eigenvector of \mathbf{E} , there is no change in direction due to \mathbf{E} , only that due to $\mathbf{\Omega}$. Therefore, the tensor $\mathbf{\Omega}$ represents the infinitesimal rotation of the triad of the eigenvectors of \mathbf{E} . It can be described by a vector \mathbf{t}^A (dual vector of the antisymmetric tensor $\mathbf{\Omega}$) in the sense that

$$\mathbf{t}^A \times d\mathbf{X} = \mathbf{\Omega}d\mathbf{X}, \quad (3.11.2)$$

where (see Section 2.21)

$$\mathbf{t}^A = \Omega_{32}\mathbf{e}_1 + \Omega_{13}\mathbf{e}_2 + \Omega_{21}\mathbf{e}_3. \quad (3.11.3)$$

Thus, $(\Omega_{32}, \Omega_{13}, \Omega_{21})$ gives the infinitesimal angle of rotation about the \mathbf{e}_1 , \mathbf{e}_2 and \mathbf{e}_3 axes of the triad of the material elements that are in the principal direction of \mathbf{E} .

3.12 TIME RATE OF CHANGE OF A MATERIAL ELEMENT

Let us consider a material element located at \mathbf{x} at time t . We wish to compute $(D/Dt)d\mathbf{x}$, the rate of change of length and direction of the material element $d\mathbf{x}$. From $\mathbf{x} = \mathbf{x}(\mathbf{X}, t)$, we have

$$d\mathbf{x} = \mathbf{x}(\mathbf{X} + d\mathbf{X}, t) - \mathbf{x}(\mathbf{X}, t). \quad (3.12.1)$$

Taking the material derivative of this equation, we obtain

$$\frac{D}{Dt}d\mathbf{x} = \frac{D}{Dt}\mathbf{x}(\mathbf{X} + d\mathbf{X}, t) - \frac{D}{Dt}\mathbf{x}(\mathbf{X}, t). \quad (3.12.2)$$

Now $D\mathbf{x}/Dt$ is the velocity, which can be expressed in material description as $\hat{\mathbf{v}}(\mathbf{X}, \mathbf{t})$ or, in spatial description, $\tilde{\mathbf{v}}(\mathbf{x}, \mathbf{t})$. (Note that $\hat{\mathbf{v}}$ and $\tilde{\mathbf{v}}$ are two different functions describing the same velocity.) That is,

$$\frac{D}{Dt}d\mathbf{x} = \hat{\mathbf{v}}(\mathbf{X}, t) - \hat{\mathbf{v}}(\mathbf{X}, t) = \tilde{\mathbf{v}}(\mathbf{x}, t). \quad (3.12.3)$$

Equation (3.12.2) becomes

$$\frac{D}{Dt}d\mathbf{x} = \hat{\mathbf{v}}(\mathbf{X} + d\mathbf{X}, t) - \hat{\mathbf{v}}(\mathbf{X}, t) = \tilde{\mathbf{v}}(\mathbf{x} + d\mathbf{x}, t) - \tilde{\mathbf{v}}(\mathbf{x}, t), \quad (3.12.4)$$

or

$$\frac{D}{Dt}d\mathbf{x} = (\nabla_{\mathbf{X}}\hat{\mathbf{v}})d\mathbf{X} = (\nabla_{\mathbf{x}}\tilde{\mathbf{v}})d\mathbf{x}. \quad (3.12.5)$$

The subscript \mathbf{X} or \mathbf{x} for the gradient ∇ serves to emphasize whether it is taken with respect to the material description or the spatial description of the velocity function.

In the following, the spatial description of the velocity function will be used exclusively so that the notation $(\nabla\mathbf{v})$ will be understood to mean $(\nabla_{\mathbf{x}}\tilde{\mathbf{v}})$. Thus we write Eq. (3.12.5) simply as

$$\frac{D}{Dt}d\mathbf{x} = (\nabla\mathbf{v})d\mathbf{x}. \quad (3.12.6)$$

With respect to rectangular Cartesian coordinates,

$$[\nabla\mathbf{v}] = \begin{bmatrix} \frac{\partial v_1}{\partial x_1} & \frac{\partial v_1}{\partial x_2} & \frac{\partial v_1}{\partial x_3} \\ \frac{\partial v_2}{\partial x_1} & \frac{\partial v_2}{\partial x_2} & \frac{\partial v_2}{\partial x_3} \\ \frac{\partial v_3}{\partial x_1} & \frac{\partial v_3}{\partial x_2} & \frac{\partial v_3}{\partial x_3} \end{bmatrix}. \quad (3.12.7)$$

3.13 THE RATE OF DEFORMATION TENSOR

The velocity gradient $(\nabla\mathbf{v})$ can be decomposed into a symmetric part and an antisymmetric part as follows:

$$(\nabla\mathbf{v}) = \mathbf{D} + \mathbf{W}, \quad (3.13.1)$$

where \mathbf{D} is the symmetric part, i.e.,

$$\mathbf{D} = \frac{1}{2} [(\nabla \mathbf{v}) + (\nabla \mathbf{v})^T], \quad (3.13.2)$$

and \mathbf{W} is the antisymmetric part, i.e.,

$$\mathbf{W} = \frac{1}{2} [(\nabla \mathbf{v}) - (\nabla \mathbf{v})^T]. \quad (3.13.3)$$

The symmetric part \mathbf{D} is known as the *rate of deformation tensor* and the antisymmetric part \mathbf{W} as the *spin tensor*. The reason for these names will become apparent soon. With respect to rectangular Cartesian coordinates, the components of \mathbf{D} and \mathbf{W} are given here:

$$[\mathbf{D}] = \begin{bmatrix} \frac{\partial v_1}{\partial x_1} & \frac{1}{2} \left(\frac{\partial v_1}{\partial x_2} + \frac{\partial v_2}{\partial x_1} \right) & \frac{1}{2} \left(\frac{\partial v_1}{\partial x_3} + \frac{\partial v_3}{\partial x_1} \right) \\ \frac{1}{2} \left(\frac{\partial v_1}{\partial x_2} + \frac{\partial v_2}{\partial x_1} \right) & \frac{\partial v_2}{\partial x_2} & \frac{1}{2} \left(\frac{\partial v_2}{\partial x_3} + \frac{\partial v_3}{\partial x_2} \right) \\ \frac{1}{2} \left(\frac{\partial v_1}{\partial x_3} + \frac{\partial v_3}{\partial x_1} \right) & \frac{1}{2} \left(\frac{\partial v_2}{\partial x_3} + \frac{\partial v_3}{\partial x_2} \right) & \frac{\partial v_3}{\partial x_3} \end{bmatrix}, \quad (3.13.4)$$

and

$$[\mathbf{W}] = \begin{bmatrix} 0 & \frac{1}{2} \left(\frac{\partial v_1}{\partial x_2} - \frac{\partial v_2}{\partial x_1} \right) & \frac{1}{2} \left(\frac{\partial v_1}{\partial x_3} - \frac{\partial v_3}{\partial x_1} \right) \\ -\frac{1}{2} \left(\frac{\partial v_1}{\partial x_2} - \frac{\partial v_2}{\partial x_1} \right) & 0 & \frac{1}{2} \left(\frac{\partial v_2}{\partial x_3} - \frac{\partial v_3}{\partial x_2} \right) \\ -\frac{1}{2} \left(\frac{\partial v_1}{\partial x_3} - \frac{\partial v_3}{\partial x_1} \right) & -\frac{1}{2} \left(\frac{\partial v_2}{\partial x_3} - \frac{\partial v_3}{\partial x_2} \right) & 0 \end{bmatrix}. \quad (3.13.5)$$

With respect to cylindrical and spherical coordinates, the matrices for \mathbf{D} take the same form as those given in Section 3.7 [Eqs. (3.7.20) and (3.7.21)] for the tensor \mathbf{E} , and those for \mathbf{W} can be obtained from the equations for the gradients given in Eq. (3.4.10) and Eq. (3.4.14) by taking their antisymmetric part.

We now show that the rate of change of length of $d\mathbf{x}$ is described by the tensor \mathbf{D} . Let $d\mathbf{x} = ds\mathbf{n}$, where \mathbf{n} is a unit vector, then

$$d\mathbf{x} \cdot d\mathbf{x} = (ds)^2. \quad (3.13.6)$$

Taking the material derivative of the above equation, we have

$$2d\mathbf{x} \cdot \frac{D}{Dt} d\mathbf{x} = 2ds \frac{D(ds)}{Dt}. \quad (3.13.7)$$

Now, from Eqs. (3.12.6) and (3.13.1),

$$d\mathbf{x} \cdot \frac{D}{Dt} d\mathbf{x} = d\mathbf{x} \cdot (\nabla \mathbf{v}) d\mathbf{x} = d\mathbf{x} \cdot (\mathbf{D} + \mathbf{W}) d\mathbf{x} = d\mathbf{x} \cdot \mathbf{D} d\mathbf{x} + d\mathbf{x} \cdot \mathbf{W} d\mathbf{x}. \quad (3.13.8)$$

But, using the definition of transpose and the antisymmetric property of \mathbf{W} , we have

$$d\mathbf{x} \cdot \mathbf{W}d\mathbf{x} = d\mathbf{x} \cdot \mathbf{W}^T d\mathbf{x} = -d\mathbf{x} \cdot \mathbf{W}d\mathbf{x} = 0. \quad (3.13.9)$$

Thus, Eq. (3.13.8) becomes

$$d\mathbf{x} \cdot \frac{D}{Dt} d\mathbf{x} = d\mathbf{x} \cdot \mathbf{D}d\mathbf{x}, \quad (3.13.10)$$

and Eq. (3.13.7) leads to

$$ds \frac{D(ds)}{Dt} = d\mathbf{x} \cdot \mathbf{D}d\mathbf{x}. \quad (3.13.11)$$

With $d\mathbf{x} = ds\mathbf{n}$, Eq. (3.13.11) can also be written:

$$\frac{1}{ds} \frac{D(ds)}{Dt} = \mathbf{n} \cdot \mathbf{D}\mathbf{n} = D_{nn} \text{ (no sum on } n). \quad (3.13.12)$$

Equation (3.13.12) states that for a material element in the direction of \mathbf{n} , its *rate of extension* (i.e., its rate of change of length per unit length) is given by D_{nn} (no sum on n). The rate of extension is known as *stretching*. In particular

- D_{11} = rate of extension for an element that is in the \mathbf{e}_1 direction,
- D_{22} = rate of extension for an element that is in the \mathbf{e}_2 direction,
- D_{33} = rate of extension for an element that is in the \mathbf{e}_3 direction.

We note that since $\mathbf{v}dt$ gives the infinitesimal displacement undergone by a particle during the time interval dt , the interpretation just given can be inferred from those for the infinitesimal strain components. Thus we obviously will have the following results (see also Prob. 3.46):

- $2D_{12}$ = rate of decrease of angle (from $\pi/2$) of two elements in \mathbf{e}_1 and \mathbf{e}_2 directions,
- $2D_{13}$ = rate of decrease of angle (from $\pi/2$) of two elements in \mathbf{e}_1 and \mathbf{e}_3 directions,
- $2D_{23}$ = rate of decrease of angle (from $\pi/2$) of two elements in \mathbf{e}_2 and \mathbf{e}_3 directions.

These rates of decrease of angle are also known as the *rates of shear*, or *shearing*. Also, the first scalar invariant of the rate of deformation tensor \mathbf{D} gives the rate of change of volume per unit volume (see also Prob. 3.47). That is,

$$D_{11} + D_{22} + D_{33} = \frac{1}{dV} \frac{D}{Dt} dV, \quad (3.13.13)$$

or, in terms of velocity components, we have

$$\frac{1}{dV} \frac{D}{Dt} dV = \frac{\partial v_i}{\partial x_i} = \text{div } \mathbf{v}. \quad (3.13.14)$$

Since \mathbf{D} is symmetric, we also have the result that there always exist three mutually perpendicular directions (eigenvectors of \mathbf{D}) along which the stretchings (eigenvalues of \mathbf{D}) include a maximum and a minimum value among all different elements extending from a material point.

Example 3.13.1

Given the velocity field:

$$v_1 = kx_2, \quad v_2 = v_3 = 0. \quad (i)$$

- (a) Find the rate of deformation tensor and spin tensor.
 (b) Determine the rate of extension of the following material elements:

$$d\mathbf{x}^{(1)} = ds_1\mathbf{e}_1, \quad d\mathbf{x}^{(2)} = ds_2\mathbf{e}_2 \quad \text{and} \quad d\mathbf{x}^{(3)} = (ds/\sqrt{5})(\mathbf{e}_1 + 2\mathbf{e}_2). \quad (\text{ii})$$

- (c) Find the maximum and the minimum rate of extension.

Solution

- (a) The matrix of the velocity gradient is

$$[\nabla\mathbf{v}] = \begin{bmatrix} 0 & k & 0 \\ 0 & 0 & 0 \\ 0 & 0 & 0 \end{bmatrix}. \quad (\text{iii})$$

So the rate of deformation tensor and the spin tensor are

$$[\mathbf{D}] = \begin{bmatrix} 0 & k/2 & 0 \\ k/2 & 0 & 0 \\ 0 & 0 & 0 \end{bmatrix} \quad \text{and} \quad [\mathbf{W}] = \begin{bmatrix} 0 & k/2 & 0 \\ -k/2 & 0 & 0 \\ 0 & 0 & 0 \end{bmatrix}. \quad (\text{iv})$$

- (b) The material element $d\mathbf{x}^{(1)}$ is currently in the \mathbf{e}_1 direction and therefore its rate of extension is $D_{11} = 0$. Similarly, the rate of extension of $d\mathbf{x}^{(2)}$ is $D_{22} = 0$. For the element $d\mathbf{x}^{(3)} = (ds/\sqrt{5})(\mathbf{e}_1 + 2\mathbf{e}_2)$,

$$\frac{1}{ds} \frac{D(ds)}{Dt} = \mathbf{n} \cdot \mathbf{D}\mathbf{n} = \frac{1}{5} [1 \quad 2 \quad 0] \begin{bmatrix} 0 & k/2 & 0 \\ k/2 & 0 & 0 \\ 0 & 0 & 0 \end{bmatrix} \begin{bmatrix} 1 \\ 2 \\ 0 \end{bmatrix} = \frac{2}{5}k. \quad (\text{v})$$

- (c) From the characteristic equation

$$|\mathbf{D} - \lambda\mathbf{1}| = -\lambda \left(\lambda^2 - \frac{k^2}{4} \right) = 0, \quad (\text{vi})$$

we determine the eigenvalues of the tensor \mathbf{D} as $\lambda_1 = 0$, $\lambda_2 = k/2$ and $\lambda_3 = -k/2$. Thus, the maximum rate of extension is $k/2$ and the minimum rate of extension is $-k/2$ (the minus sign indicates a maximum rate of shortening). The eigenvectors $\mathbf{n}_1 = (\sqrt{2}/2)(\mathbf{e}_1 + \mathbf{e}_2)$ and $\mathbf{n}_2 = (\sqrt{2}/2)(\mathbf{e}_1 - \mathbf{e}_2)$ give the directions of the elements having the maximum and the minimum stretching, respectively.

3.14 THE SPIN TENSOR AND THE ANGULAR VELOCITY VECTOR

In Section 2.21 of Chapter 2, it was shown that an antisymmetric tensor \mathbf{W} is equivalent to a vector $\boldsymbol{\omega}$ in the sense that for any vector \mathbf{a}

$$\mathbf{W}\mathbf{a} = \boldsymbol{\omega} \times \mathbf{a}. \quad (3.14.1)$$

The vector $\boldsymbol{\omega}$ is called the *dual vector* or *axial vector* of the tensor \mathbf{W} and is related to the three nonzero components of \mathbf{W} by the relation:

$$\boldsymbol{\omega} = -(W_{23}\mathbf{e}_1 + W_{31}\mathbf{e}_2 + W_{12}\mathbf{e}_3). \quad (3.14.2)$$

Thus, for the spin tensor \mathbf{W} , we have

$$\mathbf{W}d\mathbf{x} = \boldsymbol{\omega} \times d\mathbf{x}, \quad (3.14.3)$$

and therefore,

$$\frac{D}{Dt}d\mathbf{x} = (\nabla\mathbf{v})d\mathbf{x} = (\mathbf{D} + \mathbf{W})d\mathbf{x} = \mathbf{D}d\mathbf{x} + \boldsymbol{\omega} \times d\mathbf{x}. \quad (3.14.4)$$

We have already seen in the previous section that \mathbf{W} does not contribute to the rate of change of length of the material vector $d\mathbf{x}$. Thus, Eq. (3.14.3) shows that its effect on $d\mathbf{x}$ is simply to rotate it (without changing its length) with an angular velocity $\boldsymbol{\omega}$.

It should be noted, however, that the rate of deformation tensor \mathbf{D} also contributes to the rate of change of direction of $d\mathbf{x}$ as well, so that in general, most material vectors $d\mathbf{x}$ rotate with an angular velocity different from $\boldsymbol{\omega}$ (while changing their lengths). Indeed, it can be proved that in general, only the three material vectors that are in the principal directions of \mathbf{D} do rotate with the angular velocity $\boldsymbol{\omega}$ (while changing their lengths; see Prob. 3.48).

3.15 EQUATION OF CONSERVATION OF MASS

Having derived the expression for the rate of increase of volume for a particle in a continuum, we are in a position to formulate an important principle in continuum mechanics: the principle of *conservation of mass*. The principle states that if we follow an infinitesimal volume of material through its motion, its volume dV and density ρ may change but its total mass ρdV will remain unchanged. That is,

$$\frac{D}{Dt}(\rho dV) = 0, \quad (3.15.1)$$

i.e.,

$$\rho \frac{D}{Dt}(dV) + \frac{D\rho}{Dt}dV = 0. \quad (3.15.2)$$

Using Eq. (3.13.14), we obtain

$$\rho \frac{\partial v_i}{\partial x_i} + \frac{D\rho}{Dt} = 0, \quad (3.15.3)$$

or, in invariant form,

$$\rho \operatorname{div} \mathbf{v} + \frac{D\rho}{Dt} = 0, \quad (3.15.4)$$

where in the spatial description,

$$\frac{D\rho}{Dt} = \frac{\partial \rho}{\partial t} + \mathbf{v} \cdot \nabla \rho. \quad (3.15.5)$$

Equation (3.15.4) is the *equation of conservation of mass*, also known as the *equation of continuity*.

In Cartesian coordinates, Eq. (3.15.4) reads:

$$\rho \left(\frac{\partial v_1}{\partial x_1} + \frac{\partial v_2}{\partial x_2} + \frac{\partial v_3}{\partial x_3} \right) + \frac{\partial \rho}{\partial t} + v_1 \frac{\partial \rho}{\partial x_1} + v_2 \frac{\partial \rho}{\partial x_2} + v_3 \frac{\partial \rho}{\partial x_3} = 0. \quad (3.15.6)$$

In cylindrical coordinates, it reads:

$$\rho \left(\frac{\partial v_r}{\partial r} + \frac{1}{r} \frac{\partial v_\theta}{\partial \theta} + \frac{v_r}{r} + \frac{\partial v_z}{\partial z} \right) + \frac{\partial \rho}{\partial t} + v_r \frac{\partial \rho}{\partial r} + \frac{v_\theta}{r} \frac{\partial \rho}{\partial \theta} + v_z \frac{\partial \rho}{\partial z} = 0. \quad (3.15.7)$$

In spherical coordinates, it reads:

$$\rho \left(\frac{\partial v_r}{\partial r} + \frac{1}{r} \frac{\partial v_\theta}{\partial \theta} + \frac{2v_r}{r} + \frac{1}{r \sin \theta} \frac{\partial v_\phi}{\partial \phi} + \frac{v_\theta \cot \theta}{r} \right) + \frac{\partial \rho}{\partial t} + v_r \frac{\partial \rho}{\partial r} + \frac{v_\theta}{r} \frac{\partial \rho}{\partial \theta} + \frac{v_\phi}{r \sin \theta} \frac{\partial \rho}{\partial \phi} = 0. \quad (3.15.8)$$

For an *incompressible material*, the material derivative of the density is zero and the mass conservation equation reduces to simply

$$\operatorname{div} \mathbf{v} = 0. \quad (3.15.9)$$

In rectangular Cartesian coordinates:

$$\frac{\partial v_1}{\partial x_1} + \frac{\partial v_2}{\partial x_2} + \frac{\partial v_3}{\partial x_3} = 0. \quad (3.15.10)$$

In cylindrical coordinates:

$$\frac{\partial v_r}{\partial r} + \frac{1}{r} \frac{\partial v_\theta}{\partial \theta} + \frac{v_r}{r} + \frac{\partial v_z}{\partial z} = 0. \quad (3.15.11)$$

In spherical coordinates:

$$\frac{\partial v_r}{\partial r} + \frac{1}{r} \frac{\partial v_\theta}{\partial \theta} + \frac{2v_r}{r} + \frac{1}{r \sin \theta} \frac{\partial v_\phi}{\partial \phi} + \frac{v_\theta \cot \theta}{r} = 0. \quad (3.15.12)$$

Example 3.15.1

For the velocity field of

$$v_i = \frac{kx_i}{1 + kt},$$

find the density of a material particle as a function of time.

Solution

From the conservation of mass equation,

$$\frac{D\rho}{Dt} = -\rho \frac{\partial v_i}{\partial x_i} = -\rho k \frac{\delta_{ii}}{1 + kt} = -\frac{3\rho k}{1 + kt},$$

thus,

$$\int_{\rho_0}^{\rho} \frac{d\rho}{\rho} = - \int_0^t \frac{3k dt}{1 + kt},$$

from which we obtain

$$\rho = \frac{\rho_0}{(1 + kt)^3}.$$

3.16 COMPATIBILITY CONDITIONS FOR INFINITESIMAL STRAIN COMPONENTS

When any three displacement functions u_1 , u_2 and u_3 are given, one can always determine the six strain components in any region where the partial derivatives $\frac{\partial u_i}{\partial X_j}$ exist. On the other hand, when the six strain components (E_{11} , E_{22} , E_{33} , E_{12} , E_{13} , E_{23}) are arbitrarily prescribed in some region, in general, there may not exist three displacement functions u_1 , u_2 and u_3 satisfying the following six equations defining the strain-displacement relationships.

$$\frac{\partial u_1}{\partial X_1} = E_{11}, \quad (3.16.1)$$

$$\frac{\partial u_2}{\partial X_2} = E_{22}, \quad (3.16.2)$$

$$\frac{\partial u_3}{\partial X_3} = E_{33}, \quad (3.16.3)$$

$$\frac{1}{2} \left(\frac{\partial u_1}{\partial X_2} + \frac{\partial u_2}{\partial X_1} \right) = E_{12}, \quad (3.16.4)$$

$$\frac{1}{2} \left(\frac{\partial u_1}{\partial X_3} + \frac{\partial u_3}{\partial X_1} \right) = E_{13}, \quad (3.16.5)$$

$$\frac{1}{2} \left(\frac{\partial u_2}{\partial X_3} + \frac{\partial u_3}{\partial X_2} \right) = E_{23}. \quad (3.16.6)$$

For example, if we let

$$E_{11} = kX_2^2, \quad E_{22} = E_{33} = E_{12} = E_{13} = E_{23} = 0, \quad (i)$$

then, from Eq. (3.16.1),

$$\frac{\partial u_1}{\partial X_1} = E_{11} = kX_2^2 \quad \text{and therefore,} \quad u_1 = kX_1X_2^2 + f(X_2, X_3), \quad (ii)$$

and from Eq. (3.16.2),

$$\frac{\partial u_2}{\partial X_2} = E_{22} = 0 \quad \text{and therefore,} \quad u_2 = g(X_1, X_3), \quad (iii)$$

where f and g are arbitrary integration functions. Now, since $E_{12} = 0$, we must have, from Eq. (3.16.4),

$$\frac{\partial u_1}{\partial X_2} + \frac{\partial u_2}{\partial X_1} = 0. \quad (iv)$$

Using Eq. (ii) and Eq. (iii), we get from Eq. (iv)

$$2kX_1X_2 + \frac{\partial f(X_2, X_3)}{\partial X_2} + \frac{\partial g(X_1, X_3)}{\partial X_1} = 0. \quad (v)$$

Since the second or third term of the preceding equation cannot have terms of the form X_1X_2 , the preceding equation can never be satisfied. In other words, there is no displacement field corresponding to this given E_{ij} . That is, *the given six strain components are not compatible.*

We now state the following theorem: If $E_{ij}(X_1, X_2, X_3)$ are continuous functions having continuous second partial derivatives in a simply connected region, then the necessary and sufficient conditions for the existence of single-valued continuous functions u_1 , u_2 and u_3 satisfying the six equations Eq. (3.16.1) to Eq. (3.16.6) are:

$$\frac{\partial^2 E_{11}}{\partial X_2^2} + \frac{\partial^2 E_{22}}{\partial X_1^2} = 2 \frac{\partial^2 E_{12}}{\partial X_1 \partial X_2}, \quad (3.16.7)$$

$$\frac{\partial^2 E_{22}}{\partial X_3^2} + \frac{\partial^2 E_{33}}{\partial X_2^2} = 2 \frac{\partial^2 E_{23}}{\partial X_2 \partial X_3}, \quad (3.16.8)$$

$$\frac{\partial^2 E_{33}}{\partial X_1^2} + \frac{\partial^2 E_{11}}{\partial X_3^2} = 2 \frac{\partial^2 E_{31}}{\partial X_3 \partial X_1}, \quad (3.16.9)$$

$$\frac{\partial^2 E_{11}}{\partial X_2 \partial X_3} = \frac{\partial}{\partial X_1} \left(-\frac{\partial E_{23}}{\partial X_1} + \frac{\partial E_{31}}{\partial X_2} + \frac{\partial E_{12}}{\partial X_3} \right), \quad (3.16.10)$$

$$\frac{\partial^2 E_{22}}{\partial X_3 \partial X_1} = \frac{\partial}{\partial X_2} \left(-\frac{\partial E_{31}}{\partial X_2} + \frac{\partial E_{12}}{\partial X_3} + \frac{\partial E_{23}}{\partial X_1} \right), \quad (3.16.11)$$

$$\frac{\partial^2 E_{33}}{\partial X_1 \partial X_2} = \frac{\partial}{\partial X_3} \left(-\frac{\partial E_{12}}{\partial X_3} + \frac{\partial E_{23}}{\partial X_1} + \frac{\partial E_{31}}{\partial X_2} \right). \quad (3.16.12)$$

The preceding six equations are known as the *equations of compatibility* (or *integrability conditions*). That these conditions are necessary can be easily proved as follows: From

$$\frac{\partial u_1}{\partial X_1} = E_{11} \quad \text{and} \quad \frac{\partial u_2}{\partial X_2} = E_{22},$$

we get

$$\frac{\partial^2 E_{11}}{\partial X_2^2} = \frac{\partial^3 u_1}{\partial X_2^2 \partial X_1} \quad \text{and} \quad \frac{\partial^2 E_{22}}{\partial X_1^2} = \frac{\partial^3 u_2}{\partial X_1^2 \partial X_2}.$$

Now, since the left-hand side of each of the preceding two equations is, by postulate, continuous, the right-hand side of each equation is continuous, and so the order of differentiation is immaterial, so that

$$\frac{\partial^2 E_{11}}{\partial X_2^2} = \frac{\partial^2}{\partial X_1 \partial X_2} \left(\frac{\partial u_1}{\partial X_2} \right) \quad \text{and} \quad \frac{\partial^2 E_{22}}{\partial X_1^2} = \frac{\partial^2}{\partial X_1 \partial X_2} \left(\frac{\partial u_2}{\partial X_1} \right).$$

Thus,

$$\frac{\partial^2 E_{11}}{\partial X_2^2} + \frac{\partial^2 E_{22}}{\partial X_1^2} = \frac{\partial^2}{\partial X_1 \partial X_2} \left(\frac{\partial u_1}{\partial X_2} \right) + \frac{\partial^2}{\partial X_1 \partial X_2} \left(\frac{\partial u_2}{\partial X_1} \right) = \frac{\partial^2}{\partial X_1 \partial X_2} \left(\frac{\partial u_1}{\partial X_2} + \frac{\partial u_2}{\partial X_1} \right) = 2 \frac{\partial^2 E_{12}}{\partial X_1 \partial X_2}.$$

The other five equations can be similarly established. The proof that the conditions are also sufficient (under the conditions stated in the theorem) will be given in Appendix 3.1. In Example 3.16.1, we give an instance where the conditions are not sufficient for a region which is not simply connected. A region of space is said to be simply connected if every closed curve drawn in the region can be shrunk to a point, by continuous deformation, without passing out of the boundaries of the region. For example, the solid prismatic bar whose cross-section is shown in Figure 3.16-1(a) is simply connected whereas the prismatic tube represented in Figure 3.16-1(b) is not simply connected.

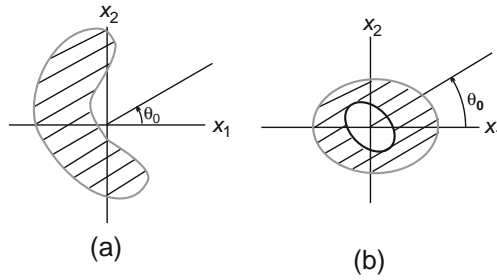

FIGURE 3.16-1

We note that since each term in all the compatibility conditions involves second partial derivatives with respect to the coordinates, *if the strain components are linear functions of coordinates, the compatibility conditions will obviously be satisfied.*

Example 3.16.1

Will the strain components obtained from the following displacement functions be compatible?

$$u_1 = X_1^3, \quad u_2 = e^{X_1}, \quad u_3 = \sin X_2.$$

Solution

The answer is yes. There is no need to check, because the displacement functions are given and therefore exist!

Example 3.16.2

Does the following strain field represent a compatible strain field?

$$[\mathbf{E}] = k \begin{bmatrix} 2X_1 & X_1 + 2X_2 & 0 \\ X_1 + 2X_2 & 2X_1 & 0 \\ 0 & 0 & 2X_3 \end{bmatrix}.$$

Solution

Since all strain components are linear functions of (X_1, X_2, X_3) , the compatibility equations are clearly satisfied. We note that the given strain components are obviously continuous functions having continuous second derivatives (in fact, continuous derivatives of all orders) in any bounded region. Thus, the existence of single-valued continuous displacement field in any bounded simply connected region is ensured by the theorem stated previously. In fact, it can be easily verified that

$$u_1 = k(X_1^2 + X_2^2), \quad u_2 = k(2X_1X_2 + X_1^2), \quad u_3 = kX_3^2.$$

Example 3.16.3

For the following strain field

$$E_{11} = -\frac{X_2}{X_1^2 + X_2^2}, \quad E_{12} = \frac{X_1}{2(X_1^2 + X_2^2)}, \quad E_{22} = E_{33} = E_{23} = E_{13} = 0, \quad (i)$$

does there exist single-valued continuous displacement fields for the cylindrical body with the normal cross-section shown in Figure 3.16-1(a)? Or for the body with the normal cross-section shown in Figure 3.16-1(b), where the origin of the axes is inside the hole of the cross-section?

Solution

Of the six compatibility conditions, only the first one needs to be checked; the others are automatically satisfied.

Now,

$$\frac{\partial E_{11}}{\partial X_2} = -\frac{(X_1^2 + X_2^2) - X_2(2X_2)}{(X_1^2 + X_2^2)^2} = \frac{X_2^2 - X_1^2}{(X_1^2 + X_2^2)^2}, \quad \frac{\partial E_{22}}{\partial X_1} = 0, \quad (\text{ii})$$

and

$$2\frac{\partial E_{12}}{\partial X_1} = \frac{(X_1^2 + X_2^2) - 2X_1^2}{(X_1^2 + X_2^2)^2} = \frac{X_2^2 - X_1^2}{(X_1^2 + X_2^2)^2} = \frac{\partial E_{11}}{\partial X_2}. \quad (\text{iii})$$

Thus, the condition

$$\frac{\partial^2 E_{11}}{\partial X_2^2} + \frac{\partial^2 E_{22}}{\partial X_1^2} = 2\frac{\partial^2 E_{12}}{\partial X_1 \partial X_2}, \quad (\text{iv})$$

is satisfied, and the existence of (u_1, u_2, u_3) is assured. In fact, it can be easily verified that for the given E_{ij} ,

$$u_1 = \arctan \frac{X_2}{X_1}, \quad u_2 = 0, \quad u_3 = 0 \quad (\text{v})$$

(to which, of course, any rigid body displacement field can be added). Now $\arctan(X_2/X_1)$ is a multiple-valued function, having infinitely many values corresponding to a point (X_1, X_2, X_3) . For example, for the point $(X_1, X_2, X_3) = (1, 0, 0)$, $\arctan(X_2/X_1) = 0, 2\pi, 4\pi$, etc. It can be made a single-valued function by the restriction

$$\theta_0 \leq \arctan \frac{X_2}{X_1} < \theta_0 + 2\pi, \quad (\text{vi})$$

for any θ_0 . For a simply connected region such as that shown in Figure 3.16-1(a), a θ_0 can be chosen so that such a restriction makes $u_1 = \arctan(X_2/X_1)$ a single-valued continuous displacement for the region. But for the body shown in Figure 3.16-1(b), the function $u_1 = \arctan(X_2/X_1)$, under the same restriction as in Eq. (vi), is discontinuous along the line $\theta = \theta_0$ in the body (in fact, u_1 jumps by the value of 2π in crossing the line). Thus, for this so-called doubly connected region, there does not exist a single-valued continuous u_1 corresponding to the given E_{ij} , even though the compatibility equations are satisfied.

3.17 COMPATIBILITY CONDITION FOR RATE OF DEFORMATION COMPONENTS

When any three velocity functions v_1, v_2 and v_3 are given, one can always determine the six rates of deformation components in any region where the partial derivatives $\partial v_i/\partial x_j$ exist. On the other hand, when the six components $(D_{11}, D_{22}, D_{33}, D_{12}, D_{13}, D_{23})$ are arbitrarily prescribed in some region, in general, there may not exist three velocity functions v_1, v_2 and v_3 , satisfying the following six equations defining the rate of deformation-velocity relationships.

$$\begin{aligned} \frac{\partial v_1}{\partial x_1} &= D_{11}, & \frac{\partial v_2}{\partial x_2} &= D_{22}, & \frac{\partial v_3}{\partial x_3} &= D_{33}, \\ \frac{\partial v_1}{\partial x_2} + \frac{\partial v_2}{\partial x_1} &= 2D_{12}, & \frac{\partial v_2}{\partial x_3} + \frac{\partial v_3}{\partial x_2} &= 2D_{23}, & \frac{\partial v_3}{\partial x_1} + \frac{\partial v_1}{\partial x_3} &= 2D_{13}. \end{aligned} \quad (3.17.1)$$

The compatibility conditions for the rate of deformation components are similar to those of the infinitesimal strain components, i.e.,

$$\frac{\partial^2 D_{11}}{\partial x_2^2} + \frac{\partial^2 D_{22}}{\partial x_1^2} = 2 \frac{\partial^2 D_{12}}{\partial x_1 \partial x_2}, \text{ etc.},$$

and

$$\frac{\partial^2 D_{11}}{\partial x_2 \partial x_3} = \frac{\partial}{\partial x_1} \left(-\frac{\partial D_{23}}{\partial x_1} + \frac{\partial D_{31}}{\partial x_2} + \frac{\partial D_{12}}{\partial x_3} \right), \text{ etc.}$$

We note that if one deals directly with differentiable velocity functions $v_i(x_1, x_2, x_3, t)$, as is often the case in fluid mechanics, the question of compatibility does not arise.

3.18 DEFORMATION GRADIENT

We recall that the general motion of a continuum is described by

$$\mathbf{x} = \mathbf{x}(\mathbf{X}, t), \quad (3.18.1)$$

where \mathbf{x} is the spatial position at time t of a material particle with material coordinate \mathbf{X} . A material element $d\mathbf{X}$ at the reference configuration is transformed, through motion, into a material element $d\mathbf{x}$ at time t . The relation between $d\mathbf{X}$ and $d\mathbf{x}$ is given by

$$d\mathbf{x} = \mathbf{x}(\mathbf{X} + d\mathbf{X}, t) - \mathbf{x}(\mathbf{X}, t) = (\nabla \mathbf{x})d\mathbf{X}, \quad (3.18.2)$$

i.e.,

$$d\mathbf{x} = \mathbf{F}d\mathbf{X}, \quad (3.18.3)$$

where

$$\mathbf{F} = \nabla \mathbf{x}, \quad (3.18.4)$$

denotes the gradient with respect to the material coordinate \mathbf{X} of the function $\mathbf{x}(\mathbf{X}, t)$. It is a tensor known as the *deformation gradient* tensor. In terms of the displacement vector \mathbf{u} , where $\mathbf{x} = \mathbf{X} + \mathbf{u}$, we have

$$\mathbf{F} = \mathbf{I} + \nabla \mathbf{u}. \quad (3.18.5)$$

We note that physics requires that $d\mathbf{x}$ can be zero only if $d\mathbf{X}$ is zero. Thus, \mathbf{F}^{-1} exists and

$$d\mathbf{X} = \mathbf{F}^{-1}d\mathbf{x}. \quad (3.18.6)$$

Also, physics does not allow for a reflection in deformation, so that $\mathbf{Fe}_1 \cdot \mathbf{Fe}_2 \times \mathbf{Fe}_3$ must have the same sign as $\mathbf{e}_1 \cdot \mathbf{e}_2 \times \mathbf{e}_3$, which is positive.[†] Since $\mathbf{Fe}_1 \cdot \mathbf{Fe}_2 \times \mathbf{Fe}_3 = \det \mathbf{F}$ (note: $\mathbf{a} \cdot \mathbf{b} \times \mathbf{c} = \text{determinant whose rows are components of the vectors } \mathbf{a}, \mathbf{b} \text{ and } \mathbf{c}$), we have

$$\det \mathbf{F} > 0. \quad (3.18.7)$$

[†]So long as $\{\mathbf{e}_1, \mathbf{e}_2, \mathbf{e}_3\}$ is a right-handed basis.

Example 3.18.1

Given the following motions in rectangular coordinates:

$$x_1 = X_1 + \alpha X_1^2 t, \quad x_2 = X_2 - k(X_2 + X_3)t, \quad x_3 = X_3 + k(X_2 - X_3)t.$$

Obtain the deformation gradient at $t = 0$ and at $t = 1/k$.

Solution

$$[\mathbf{F}] = \begin{bmatrix} \frac{\partial x_i}{\partial X_j} \end{bmatrix} = \begin{bmatrix} 1 + 2\alpha X_1 t & 0 & 0 \\ 0 & 1 - kt & -kt \\ 0 & kt & 1 - kt \end{bmatrix}.$$

At $t = 0$,

$$[\mathbf{F}] = \begin{bmatrix} 1 & 0 & 0 \\ 0 & 1 & 0 \\ 0 & 0 & 1 \end{bmatrix} = [\mathbf{I}],$$

and at $t = 1/k$,

$$[\mathbf{F}] = \begin{bmatrix} 1 + 2(\alpha/k)X_1 & 0 & 0 \\ 0 & 0 & -1 \\ 0 & 1 & 0 \end{bmatrix}.$$

3.19 LOCAL RIGID BODY MOTION

In Section 3.6, we discussed the case where the entire body undergoes rigid body displacements from the configuration at a reference time t_0 to that at a particular time t . For a body in general motion, however, it is possible that the body as a whole undergoes deformations while some (infinitesimally) small volumes of material inside the body undergo rigid body motion. For example, for the motion given in the last example, at $t = 1/k$ and $X_1 = 0$,

$$[\mathbf{F}] = \begin{bmatrix} 1 & 0 & 0 \\ 0 & 0 & -1 \\ 0 & 1 & 0 \end{bmatrix}.$$

It is easy to verify that the preceding \mathbf{F} is a rotation tensor \mathbf{R} (i.e., $\mathbf{F}\mathbf{F}^T = \mathbf{I}$ and $\det \mathbf{F} = +1$). Thus, every infinitesimal material volume with material coordinates $(0, X_2, X_3)$ undergoes a rigid body displacement from the reference position to the position at $t = 1/k$.

3.20 FINITE DEFORMATION

Deformations at a material point \mathbf{X} of a body are characterized by changes of distances between any pair of material points within a small neighborhood of \mathbf{X} . Since, through motion, a material element $d\mathbf{X}$ becomes $d\mathbf{x} = \mathbf{F}d\mathbf{X}$, whatever deformation there may be at \mathbf{X} is embodied in the deformation gradient. We have

already seen that if \mathbf{F} is a proper orthogonal tensor, there is no deformation at \mathbf{X} . In the following, we first consider the case where the deformation gradient \mathbf{F} is a positive definite symmetric tensor before going to the more general cases.

We shall use the notation \mathbf{U} for a deformation gradient that is symmetric and positive definite (i.e., for any real vector \mathbf{a} , $\mathbf{a} \cdot \mathbf{U}\mathbf{a} \geq 0$, where $\mathbf{a} \cdot \mathbf{U}\mathbf{a} = 0$ if and only if $\mathbf{a} = \mathbf{0}$). Clearly the eigenvalues of such a tensor are all positive. For such a deformation gradient, we write

$$d\mathbf{x} = \mathbf{U}d\mathbf{X}. \tag{3.20.1}$$

In this case, the material within a small neighborhood of \mathbf{X} is said to be in a state of *pure stretch* deformation (from the reference configuration). Of course, Eq. (3.20.1) includes the special case where the motion is homogeneous, i.e., $\mathbf{x} = \mathbf{U}\mathbf{X}$, ($\mathbf{U} = \text{constant tensor}$), in which case, the entire body is in a state of pure stretch.

Since \mathbf{U} is real and symmetric, there always exist three mutually perpendicular directions with respect to which the matrix of \mathbf{U} is diagonal. Thus, if $\mathbf{e}_1, \mathbf{e}_2, \mathbf{e}_3$ are these principal directions, with $\lambda_1, \lambda_2, \lambda_3$ as their eigenvalues, respectively, we have

$$[\mathbf{U}] = \begin{bmatrix} \lambda_1 & 0 & 0 \\ 0 & \lambda_2 & 0 \\ 0 & 0 & \lambda_3 \end{bmatrix}_{\{\mathbf{e}_i\}}. \tag{3.20.2}$$

Thus, for the element $d\mathbf{X}^{(1)} = dX_1\mathbf{e}_1$, Eq. (3.20.2) gives

$$d\mathbf{x}^{(1)} = \lambda_1 dX_1\mathbf{e}_1 = \lambda_1 d\mathbf{X}^{(1)}. \tag{3.20.3}$$

Similarly, for the elements $d\mathbf{X}^{(2)} = dX_2\mathbf{e}_2$ and $d\mathbf{X}^{(3)} = dX_3\mathbf{e}_3$, we have

$$d\mathbf{x}^{(2)} = \lambda_2 d\mathbf{X}^{(2)}, \tag{3.20.4}$$

and

$$d\mathbf{x}^{(3)} = \lambda_3 d\mathbf{X}^{(3)}. \tag{3.20.5}$$

We see that along each of these directions, the deformed element is in the same direction as the undeformed element. If the eigenvalues are distinct, these will be the only elements that do not change their directions. The ratio of the deformed length to the original length is called the *stretch*, i.e.,

$$\text{Stretch} = \frac{|d\mathbf{x}|}{|d\mathbf{X}|}. \tag{3.20.6}$$

Thus, the eigenvalues of \mathbf{U} are the principal stretches; they therefore include the maximum and the minimum stretches.

Example 3.20.1

Given that at time t

$$x_1 = 3X_1, \quad x_2 = 4X_2, \quad x_3 = X_3. \tag{i}$$

Referring to Figure 3.20-1, find the stretches for the following material lines: (a) OP , (b) OQ , and (c) OB .

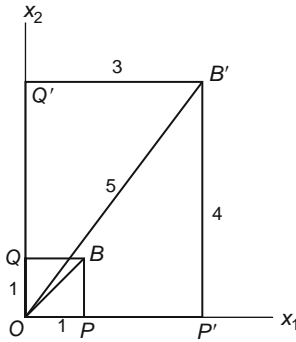

FIGURE 3.20-1

Solution

The matrix of the deformation gradient for the given motion is

$$[\mathbf{F}] = \begin{bmatrix} 3 & 0 & 0 \\ 0 & 4 & 0 \\ 0 & 0 & 1 \end{bmatrix}, \quad (\text{ii})$$

which is a symmetric and positive definite matrix and which is independent of X_i (i.e., the same for all material points). Thus, the given deformation is a homogeneous pure stretch deformation. The eigenvectors are obviously \mathbf{e}_1 , \mathbf{e}_2 , \mathbf{e}_3 with corresponding eigenvalues 3, 4, and 1. Thus:

- (a) At the deformed state, the line OP triples its original length and remains parallel to the x_1 -axis; stretch $= \lambda_1 = 3$.
- (b) At the deformed state, the line OQ quadruples its original length and remains parallel to the x_2 -axis; stretch $= \lambda_2 = 4$. This is the maximum stretch for the given motion.
- (c) For the material line OB ,

$$d\mathbf{X} = dS \left(\frac{\mathbf{e}_1 + \mathbf{e}_2}{\sqrt{2}} \right). \quad (\text{iii})$$

Its deformed vector is $d\mathbf{x} = \mathbf{F}d\mathbf{X}$:

$$[d\mathbf{x}] = \frac{dS}{\sqrt{2}} \begin{bmatrix} 3 & 0 & 0 \\ 0 & 4 & 0 \\ 0 & 0 & 1 \end{bmatrix} \begin{bmatrix} 1 \\ 1 \\ 0 \end{bmatrix} = \frac{dS}{\sqrt{2}} \begin{bmatrix} 3 \\ 4 \\ 0 \end{bmatrix}, \quad (\text{iv})$$

i.e.,

$$d\mathbf{x} = \frac{dS}{\sqrt{2}} (3\mathbf{e}_1 + 4\mathbf{e}_2). \quad (\text{v})$$

Thus, for OB , the stretch is

$$\frac{|d\mathbf{x}|}{|d\mathbf{X}|} = \frac{(5dS/\sqrt{2})}{dS} = \frac{5}{1.414} = 3.54. \tag{vi}$$

Before deformation, the material line OB makes an angle of 45° with the x_1 - axis. In the deformed state, from Eq. (v), we see that it makes an angle of $\tan^{-1}(4/3)$. The preceding results are easily confirmed by the geometry shown in Figure 3.20-1.

Example 3.20.2

For a material sphere with center at \mathbf{X} and described by $|d\mathbf{X}| = \epsilon$, under a symmetric deformation gradient \mathbf{U} , what does the sphere become after the deformation?

Solution

Let $\mathbf{e}_1, \mathbf{e}_2, \mathbf{e}_3$ be the principal directions for \mathbf{U} . Then, with respect to $\{\mathbf{e}_1, \mathbf{e}_2, \mathbf{e}_3\}$, a material element $d\mathbf{X}$ can be written

$$d\mathbf{X} = dX_1\mathbf{e}_1 + dX_2\mathbf{e}_2 + dX_3\mathbf{e}_3. \tag{3.20.7}$$

In the deformed state, this material vector becomes

$$d\mathbf{x} = dx_1\mathbf{e}_1 + dx_2\mathbf{e}_2 + dx_3\mathbf{e}_3. \tag{3.20.8}$$

\mathbf{U} is diagonal with diagonal elements λ_1, λ_2 and λ_3 ; therefore, $d\mathbf{x} = \mathbf{U}d\mathbf{X}$ gives

$$dx_1 = \lambda_1 dX_1, \quad dx_2 = \lambda_2 dX_2, \quad dx_3 = \lambda_3 dX_3. \tag{3.20.9}$$

Thus, the sphere

$$(dX_1)^2 + (dX_2)^2 + (dX_3)^2 = \epsilon^2, \tag{3.20.10}$$

becomes

$$\left(\frac{dx_1}{\lambda_1}\right)^2 + \left(\frac{dx_2}{\lambda_2}\right)^2 + \left(\frac{dx_3}{\lambda_3}\right)^2 = \epsilon^2. \tag{3.20.11}$$

This is the equation of an ellipsoid with its axis parallel to the eigenvectors of \mathbf{U} (see Figure 3.20-2).

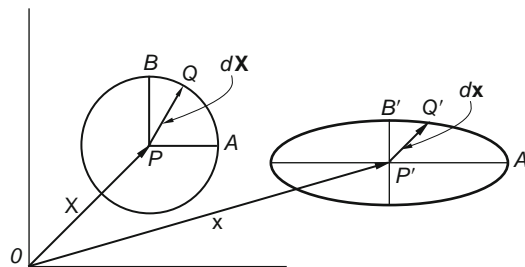

FIGURE 3.20-2

3.21 POLAR DECOMPOSITION THEOREM

In the previous two sections, we considered two special deformation gradients \mathbf{F} : a proper orthogonal \mathbf{F} (denoted by \mathbf{R}), describing rigid body displacements, and a symmetric positive definite \mathbf{F} (denoted by \mathbf{U}), describing pure stretch deformation tensor. It can be shown that for any real tensor \mathbf{F} with a nonzero determinant (i.e., \mathbf{F}^{-1} exists), one can always decompose it into the product of a proper orthogonal tensor and a symmetric tensor. That is,

$$\mathbf{F} = \mathbf{R}\mathbf{U}, \quad (3.21.1)$$

or

$$\mathbf{F} = \mathbf{V}\mathbf{R}. \quad (3.21.2)$$

In the preceding two equations, \mathbf{U} and \mathbf{V} are positive definite symmetric tensors, known as the *right stretch tensor* and *left stretch tensor*, respectively, and \mathbf{R} (the same in both equations) is a proper orthogonal tensor. Eqs. (3.21.1) and (3.21.2) are known as the *polar decomposition theorem*. The decomposition is unique in that there is only one \mathbf{R} , one \mathbf{U} , and one \mathbf{V} satisfying the preceding equations. The proof of this theorem consists of two steps: (1) Establishing a procedure that always enables one to obtain a positive definite symmetric tensor \mathbf{U} and a proper orthogonal tensor \mathbf{R} (or a positive definite symmetric tensor \mathbf{V} and a proper orthogonal tensor \mathbf{R}) that satisfy Eq. (3.21.1) [or Eq. (3.21.2)] and (2) proving that the \mathbf{U} , \mathbf{V} , and \mathbf{R} so obtained are unique.

The procedures for obtaining the tensors \mathbf{U} , \mathbf{V} , and \mathbf{R} for a given \mathbf{F} will be demonstrated in Example 3.22.1. The proof of the uniqueness of the decompositions will be given in Example 3.22.2. Before doing that, we shall first discuss the geometric interpretations of the preceding two equations.

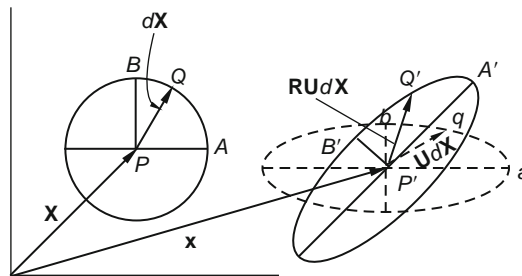

FIGURE 3.21-1

For any material element $d\mathbf{X}$ at \mathbf{X} , the deformation gradient transforms it (i.e., $d\mathbf{X}$) into a vector $d\mathbf{x}$:

$$d\mathbf{x} = \mathbf{F}d\mathbf{X} = \mathbf{R}\mathbf{U}d\mathbf{X}. \quad (3.21.3)$$

Now, $\mathbf{U}d\mathbf{X}$ describes a pure stretch deformation (Section 3.20) in which there are three mutually perpendicular directions (the eigenvectors of \mathbf{U}) along each of which the material element $d\mathbf{X}$ stretches (i.e., becomes longer or shorter), but does not rotate. Figure 3.20-2 of Example 3.20.2 depicts the effect of \mathbf{U} on a spherical volume $|d\mathbf{X}| = \text{constant}$. Now, in Figure 3.21-1, under \mathbf{U} , the spherical volume at \mathbf{X} becomes an ellipsoid at \mathbf{x} , depicted in dashed lines. The effect of \mathbf{R} in $\mathbf{R}(\mathbf{U}d\mathbf{X})$ is then simply to rotate this (dashed line) ellipsoid through a rigid body rotation to its final configuration, depicted as a (solid line) ellipsoid

in the same figure (Figure 3.21-1). Similarly, the effect of the same deformation gradient can be viewed as a rigid body rotation (described by \mathbf{R}) of the sphere followed by a pure stretch of the sphere resulting in the same ellipsoid as described in the last paragraph.

From the polar decomposition, $\mathbf{F} = \mathbf{R}\mathbf{U} = \mathbf{V}\mathbf{R}$, it follows immediately that

$$\mathbf{U} = \mathbf{R}^T\mathbf{V}\mathbf{R}. \quad (3.21.4)$$

While geometrically speaking, it makes no difference whether we view the motion as being a rotation followed by a pure stretch or as a pure stretch followed by a rotation, they do lead to two different stretch tensors (\mathbf{U} or \mathbf{V}) whose components have different geometrical meanings (to be discussed in the following several sections). Furthermore, based on these two stretch tensors, two commonly used deformation tensors are defined (see Sections 3.23 and 3.25), the so-called right Cauchy-Green tensor $\mathbf{C}(\equiv \mathbf{U}^2)$ and the left Cauchy-Green tensor $\mathbf{B}(\equiv \mathbf{V}^2)$. In Chapter 5, we show that the tensor \mathbf{B} is objective (independent of observer), whereas the tensor \mathbf{C} is nonobjective. This important difference is relevant to the formulation of the constitutive equations for a continuum under large deformation (see Part C, Chapter 5).

3.22 CALCULATION OF STRETCH AND ROTATION TENSORS FROM THE DEFORMATION GRADIENT

Using Eq. (3.21.1), we have

$$\mathbf{F}^T\mathbf{F} = (\mathbf{R}\mathbf{U})^T(\mathbf{R}\mathbf{U}) = \mathbf{U}^T\mathbf{R}^T\mathbf{R}\mathbf{U} = \mathbf{U}^T\mathbf{U} = \mathbf{U}\mathbf{U}, \quad (3.22.1)$$

that is,

$$\mathbf{U}^2 = \mathbf{F}^T\mathbf{F}. \quad (3.22.2)$$

For a given \mathbf{F} , Eq. (3.22.2) allows us to calculate a unique \mathbf{U} , which is positive definite (see example that follows). Once \mathbf{U} is obtained, \mathbf{R} can be obtained from the equation

$$\mathbf{R} = \mathbf{F}\mathbf{U}^{-1}. \quad (3.22.3)$$

We now demonstrate that the \mathbf{R} so obtained is indeed an orthogonal tensor. We have

$$\mathbf{R}^T\mathbf{R} = (\mathbf{F}\mathbf{U}^{-1})^T(\mathbf{F}\mathbf{U}^{-1}) = (\mathbf{U}^{-1})^T\mathbf{F}^T\mathbf{F}\mathbf{U}^{-1} = \mathbf{U}^{-1}\mathbf{U}\mathbf{U}^{-1} = \mathbf{I}. \quad (3.22.4)$$

The left stretch tensor \mathbf{V} can be obtained from

$$\mathbf{V} = \mathbf{F}\mathbf{R}^T = \mathbf{R}\mathbf{U}\mathbf{R}^T. \quad (3.22.5)$$

Example 3.22.1

Given

$$x_1 = X_1, \quad x_2 = -3X_3, \quad x_3 = 2X_2.$$

Find (a) the deformation gradient \mathbf{F} , (b) the right stretch tensor \mathbf{U} , (c) the rotation tensor \mathbf{R} , and (d) the left stretch tensor \mathbf{V} .

Solution

$$(a) \quad [\mathbf{F}] = \begin{bmatrix} \frac{\partial x_i}{\partial X_j} \end{bmatrix} = \begin{bmatrix} 1 & 0 & 0 \\ 0 & 0 & -3 \\ 0 & 2 & 0 \end{bmatrix},$$

$$(b) \quad [\mathbf{U}^2] = [\mathbf{F}]^T [\mathbf{F}] = \begin{bmatrix} 1 & 0 & 0 \\ 0 & 0 & 2 \\ 0 & -3 & 0 \end{bmatrix} \begin{bmatrix} 1 & 0 & 0 \\ 0 & 0 & -3 \\ 0 & 2 & 0 \end{bmatrix} = \begin{bmatrix} 1 & 0 & 0 \\ 0 & 4 & 0 \\ 0 & 0 & 9 \end{bmatrix}.$$

There is only one positive definite root for the preceding equation, which is (see Appendix 3.3).

$$[\mathbf{U}] = \begin{bmatrix} 1 & 0 & 0 \\ 0 & 2 & 0 \\ 0 & 0 & 3 \end{bmatrix}.$$

$$(c) \quad [\mathbf{R}] = [\mathbf{F}] [\mathbf{U}^{-1}] = \begin{bmatrix} 1 & 0 & 0 \\ 0 & 0 & -3 \\ 0 & 2 & 0 \end{bmatrix} \begin{bmatrix} 1 & 0 & 0 \\ 0 & 1/2 & 0 \\ 0 & 0 & 1/3 \end{bmatrix} = \begin{bmatrix} 1 & 0 & 0 \\ 0 & 0 & -1 \\ 0 & 1 & 0 \end{bmatrix}.$$

$$(d) \quad [\mathbf{V}] = [\mathbf{F}] [\mathbf{R}^T] = \begin{bmatrix} 1 & 0 & 0 \\ 0 & 0 & -3 \\ 0 & 2 & 0 \end{bmatrix} \begin{bmatrix} 1 & 0 & 0 \\ 0 & 0 & 1 \\ 0 & -1 & 0 \end{bmatrix} = \begin{bmatrix} 1 & 0 & 0 \\ 0 & 3 & 0 \\ 0 & 0 & 2 \end{bmatrix},$$

or, using Eq. (3.22.5),

$$[\mathbf{V}] = [\mathbf{R}] [\mathbf{U}] [\mathbf{R}^T] = \begin{bmatrix} 1 & 0 & 0 \\ 0 & 0 & -1 \\ 0 & 1 & 0 \end{bmatrix} \begin{bmatrix} 1 & 0 & 0 \\ 0 & 2 & 0 \\ 0 & 0 & 3 \end{bmatrix} \begin{bmatrix} 1 & 0 & 0 \\ 0 & 0 & 1 \\ 0 & -1 & 0 \end{bmatrix} = \begin{bmatrix} 1 & 0 & 0 \\ 0 & 3 & 0 \\ 0 & 0 & 2 \end{bmatrix}.$$

In the preceding example, the calculation of $[\mathbf{U}]$ is simple because $[\mathbf{F}^T \mathbf{F}]$ happens to be diagonal. If $[\mathbf{F}^T \mathbf{F}]$ is not diagonal, one can first diagonalize it and obtain the one positive definite diagonal matrix $[\mathbf{U}]$, with respect to the principal axes of $[\mathbf{F}^T \mathbf{F}]$. After that, one can then use the transformation law discussed in Chapter 2 to obtain the matrix with respect to the original basis (see Example 3.23.1).

Example 3.22.2

Show that (a) if $\mathbf{F} = \mathbf{R}_1 \mathbf{U}_1 = \mathbf{R}_2 \mathbf{U}_2$, then $\mathbf{U}_1 = \mathbf{U}_2$ and $\mathbf{R}_1 = \mathbf{R}_2$ and (b) if $\mathbf{F} = \mathbf{R} \mathbf{U} = \mathbf{V} \mathbf{R}'$, then $\mathbf{R} = \mathbf{R}'$. That is, the decomposition of \mathbf{F} is unique.

Solution

- (a) Assuming that there are two proper orthogonal tensors \mathbf{R}_1 and \mathbf{R}_2 and two positive definite symmetric tensors \mathbf{U}_1 and \mathbf{U}_2 such that

$$\mathbf{F} = \mathbf{R}_1 \mathbf{U}_1 = \mathbf{R}_2 \mathbf{U}_2. \quad (\text{i})$$

Then $(\mathbf{R}_1 \mathbf{U}_1)^\top = (\mathbf{R}_2 \mathbf{U}_2)^\top$ so that

$$\mathbf{U}_1 (\mathbf{R}_1)^\top = \mathbf{U}_2 (\mathbf{R}_2)^\top. \quad (\text{ii})$$

From Eq. (i) and Eq. (ii), we have

$$\mathbf{U}_1 (\mathbf{R}_1)^\top \mathbf{R}_1 \mathbf{U}_1 = \mathbf{U}_2 (\mathbf{R}_2)^\top \mathbf{R}_2 \mathbf{U}_2.$$

That is,

$$\mathbf{U}_1^2 = \mathbf{U}_2^2. \quad (\text{iii})$$

Thus, \mathbf{U}_1 and \mathbf{U}_2 are the same positive definite tensors (see Appendix 3.3). That is,

$$\mathbf{U}_1 = \mathbf{U}_2 = \mathbf{U}.$$

Now, from $\mathbf{R}_1 \mathbf{U} = \mathbf{R}_2 \mathbf{U}$, we have $(\mathbf{R}_1 - \mathbf{R}_2) \mathbf{U} = 0$, where \mathbf{U} is positive definite (all eigenvalues $\lambda_i > 0$), therefore, $\mathbf{R}_1 - \mathbf{R}_2 = 0$ (see Prob. 3.74). That is,

$$\mathbf{R}_1 = \mathbf{R}_2 = \mathbf{R}.$$

- (b) Since

$$\mathbf{F} = \mathbf{V} \mathbf{R}' = \mathbf{R}' (\mathbf{R}')^{-1} \mathbf{V} \mathbf{R}' = \mathbf{R}' \{ (\mathbf{R}')^{-1} \mathbf{V} \mathbf{R}' \} = \mathbf{R} \mathbf{U},$$

therefore, from the results of (a)

$$\mathbf{R}' = \mathbf{R},$$

and

$$\mathbf{U} = \mathbf{R}^{-1} \mathbf{V} \mathbf{R} = \mathbf{R}^\top \mathbf{V} \mathbf{R}.$$

From the decomposition theorem, we see that what is responsible for the deformation of a volume of material in a continuum in general motion is the stretch tensor, either the *right stretch tensor* \mathbf{U} or the *left stretch tensor* \mathbf{V} . Obviously, $\mathbf{U}^2 (\equiv \mathbf{C})$ and $\mathbf{V}^2 (\equiv \mathbf{B})$ also characterize the deformation, as do many other tensors related to them, such as the Lagrangean strain tensor \mathbf{E}^* (Section 3.24) and the Eulerian strain tensor \mathbf{e}^* (Section 3.26). In the following we discuss these tensors in detail, including the geometrical meanings of their components. It is useful to be familiar with all these tensors not only because they appear in many works on continuum mechanics but also because one particular tensor may be more suitable to a particular problem than others. For example, the tensor \mathbf{E}^* is more suitable for problems formulated in terms of the material coordinates, whereas \mathbf{e}^* is more suitable in terms of the spatial coordinates. As another example, the equation $\mathbf{T} = \alpha \mathbf{B}$, where \mathbf{T} is the Cauchy stress tensor (to be defined in Chapter 4) and α is a constant, is an acceptable stress-deformation relationship,

whereas $\mathbf{T} = \alpha\mathbf{C}$ is not because the tensor \mathbf{B} is independent of observers whereas the tensor \mathbf{C} is not, and all laws of mechanics must be independent of observers (see Part C, Chapter 5).

In the following sections, we discuss those tensors that have been commonly used to describe finite deformations for a continuum.

3.23 RIGHT CAUCHY-GREEN DEFORMATION TENSOR

Let

$$\mathbf{C} = \mathbf{U}^2, \quad (3.23.1)$$

where \mathbf{U} is the right stretch tensor. The tensor \mathbf{C} is known as the *right Cauchy-Green deformation tensor* (also known as *Green's deformation tensor*). We note that if there is no deformation, $\mathbf{U} = \mathbf{C} = \mathbf{I}$. From Eq. (3.22.2), we have

$$\mathbf{C} = \mathbf{F}^T\mathbf{F}. \quad (3.23.2)$$

The components of \mathbf{C} have very simple geometric meanings, which we describe here.

Consider two material elements $d\mathbf{X}^{(1)}$ and $d\mathbf{X}^{(2)}$, which deform into $d\mathbf{x}^{(1)} = \mathbf{F}d\mathbf{X}^{(1)}$ and $d\mathbf{x}^{(2)} = \mathbf{F}d\mathbf{X}^{(2)}$. We have

$$d\mathbf{x}^{(1)} \cdot d\mathbf{x}^{(2)} = \mathbf{F}d\mathbf{X}^{(1)} \cdot \mathbf{F}d\mathbf{X}^{(2)} = d\mathbf{X}^{(1)} \cdot \mathbf{F}^T\mathbf{F}d\mathbf{X}^{(2)}, \quad (3.23.3)$$

i.e.,

$$d\mathbf{x}^{(1)} \cdot d\mathbf{x}^{(2)} = d\mathbf{X}^{(1)} \cdot \mathbf{C}d\mathbf{X}^{(2)}. \quad (3.23.4)$$

Thus, if $d\mathbf{x} = ds_1\mathbf{n}$ is the deformed vector of the material element $d\mathbf{X} = dS_1\mathbf{e}_1$, then letting $d\mathbf{X}^{(1)} = d\mathbf{X}^{(2)} = d\mathbf{X} = dS_1\mathbf{e}_1$ in Eq. (3.23.4), we get

$$(ds_1)^2 = (dS_1)^2\mathbf{e}_1 \cdot \mathbf{C}\mathbf{e}_1 \quad \text{for } d\mathbf{X}^{(1)} = dS_1\mathbf{e}_1. \quad (3.23.5)$$

That is

$$C_{11} = \left(\frac{ds_1}{dS_1}\right)^2 \quad \text{for a material element } d\mathbf{X} = dS_1\mathbf{e}_1. \quad (3.23.6)$$

Similarly,

$$C_{22} = \left(\frac{ds_2}{dS_2}\right)^2 \quad \text{for a material element } d\mathbf{X} = dS_2\mathbf{e}_2, \quad (3.23.7)$$

and

$$C_{33} = \left(\frac{ds_3}{dS_3}\right)^2 \quad \text{for a material element } d\mathbf{X} = dS_3\mathbf{e}_3. \quad (3.23.8)$$

It is important to note that, in general, $U_{11} \neq \sqrt{C_{11}}$, $U_{22} \neq \sqrt{C_{22}}$, $U_{33} \neq \sqrt{C_{33}}$, etc., so that the stretches are in general not given by the diagonal elements of $[\mathbf{U}]$, except when it is a diagonal matrix.

Next, consider two material elements $d\mathbf{X}^{(1)} = dS_1\mathbf{e}_1$ and $d\mathbf{X}^{(2)} = dS_2\mathbf{e}_2$, which deform into $d\mathbf{x}^{(1)} = ds_1\mathbf{m}$ and $d\mathbf{x}^{(2)} = ds_2\mathbf{n}$, where \mathbf{m} and \mathbf{n} are unit vectors having an angle of β between them. Then Eq. (3.23.4) gives

$$ds_1 ds_2 \cos \beta = dS_1 dS_2 \mathbf{e}_1 \cdot \mathbf{C} \mathbf{e}_2, \quad (3.23.9)$$

that is,

$$C_{12} = \frac{ds_1 ds_2}{dS_1 dS_2} \cos (d\mathbf{x}^{(1)}, d\mathbf{x}^{(2)}), \quad \text{for } d\mathbf{X}^{(1)} = dS_1 \mathbf{e}_1 \quad \text{and} \quad d\mathbf{X}^{(2)} = dS_2 \mathbf{e}_2. \quad (3.23.10)$$

Similarly,

$$C_{13} = \frac{ds_1 ds_3}{dS_1 dS_3} \cos (d\mathbf{x}^{(1)}, d\mathbf{x}^{(3)}), \quad \text{for } d\mathbf{X}^{(1)} = dS_1 \mathbf{e}_1 \quad \text{and} \quad d\mathbf{X}^{(3)} = dS_3 \mathbf{e}_3 \quad (3.23.11)$$

and

$$C_{23} = \frac{ds_2 ds_3}{dS_2 dS_3} \cos (d\mathbf{x}^{(2)}, d\mathbf{x}^{(3)}), \quad \text{for } d\mathbf{X}^{(2)} = dS_2 \mathbf{e}_2 \quad \text{and} \quad d\mathbf{X}^{(3)} = dS_3 \mathbf{e}_3. \quad (3.23.12)$$

Example 3.23.1

Given

$$x_1 = X_1 + 2X_2, \quad x_2 = X_2, \quad x_3 = X_3. \quad (i)$$

- (a) Obtain the right Cauchy-Green deformation tensor \mathbf{C} .
- (b) Obtain the principal values of \mathbf{C} and the corresponding principal directions.
- (c) Obtain the matrices of \mathbf{U} and \mathbf{U}^{-1} with respect to the principal directions.
- (d) Obtain the matrices \mathbf{U} and \mathbf{U}^{-1} with respect to the $\{\mathbf{e}_j\}$ basis.
- (e) Obtain the matrix of \mathbf{R} with respect to the $\{\mathbf{e}_j\}$ basis.

Solution

- (a) From (i), we obtain

$$[\mathbf{F}] = \begin{bmatrix} 1 & 2 & 0 \\ 0 & 1 & 0 \\ 0 & 0 & 1 \end{bmatrix}. \quad (ii)$$

$$[\mathbf{C}] = [\mathbf{F}]^T [\mathbf{F}] = \begin{bmatrix} 1 & 0 & 0 \\ 2 & 1 & 0 \\ 0 & 0 & 1 \end{bmatrix} \begin{bmatrix} 1 & 2 & 0 \\ 0 & 1 & 0 \\ 0 & 0 & 1 \end{bmatrix} = \begin{bmatrix} 1 & 2 & 0 \\ 2 & 5 & 0 \\ 0 & 0 & 1 \end{bmatrix}. \quad (iii)$$

The eigenvalues of \mathbf{C} and their corresponding eigenvectors are easily found to be

$$\lambda_1 = 5.828, \quad \mathbf{n}_1 = \frac{1}{2.613} (\mathbf{e}_1 + 2.414\mathbf{e}_2) = 0.3827\mathbf{e}_1 + 0.9238\mathbf{e}_2,$$

$$\lambda_2 = 0.1716, \quad \mathbf{n}_2 = \frac{1}{1.0824} (\mathbf{e}_1 - 0.4142\mathbf{e}_2) = 0.9238\mathbf{e}_1 - 0.3827\mathbf{e}_2, \quad (iv)$$

$$\lambda_3 = 1, \quad \mathbf{n}_3 = \mathbf{e}_3.$$

The matrix of \mathbf{C} with respect to the principal axes of \mathbf{C} is

$$[\mathbf{C}] = \begin{bmatrix} 5.828 & 0 & 0 \\ 0 & 0.1716 & 0 \\ 0 & 0 & 1 \end{bmatrix}. \quad (\text{v})$$

(c) The matrix of \mathbf{U} and \mathbf{U}^{-1} with respect to the principal axes of \mathbf{C} is

$$[\mathbf{U}]_{\mathbf{n}_i} = \begin{bmatrix} \sqrt{5.828} & 0 & 0 \\ 0 & \sqrt{0.1716} & 0 \\ 0 & 0 & 1 \end{bmatrix} = \begin{bmatrix} 2.414 & 0 & 0 \\ 0 & 0.4142 & 0 \\ 0 & 0 & 1 \end{bmatrix}, \quad (\text{vi})$$

$$[\mathbf{U}^{-1}]_{\mathbf{n}_i} = \begin{bmatrix} 1/2.414 & 0 & 0 \\ 0 & 1/0.4142 & 0 \\ 0 & 0 & 1 \end{bmatrix} = \begin{bmatrix} 0.4142 & 0 & 0 \\ 0 & 2.4142 & 0 \\ 0 & 0 & 1 \end{bmatrix}. \quad (\text{vii})$$

(d) The matrices of \mathbf{U} and \mathbf{U}^{-1} with respect to the $\{\mathbf{e}_i\}$ basis are given by:

$$\begin{aligned} [\mathbf{U}]_{\mathbf{e}_i} &= \begin{bmatrix} 0.3827 & 0.9238 & 0 \\ 0.9238 & -0.3827 & 0 \\ 0 & 0 & 1 \end{bmatrix} \begin{bmatrix} 2.414 & 0 & 0 \\ 0 & 0.4142 & 0 \\ 0 & 0 & 1 \end{bmatrix} \begin{bmatrix} 0.3827 & 0.9238 & 0 \\ 0.9238 & -0.3827 & 0 \\ 0 & 0 & 1 \end{bmatrix} \\ &= \begin{bmatrix} 0.7070 & 0.7070 & 0 \\ 0.7070 & 2.121 & 0 \\ 0 & 0 & 1 \end{bmatrix}, \end{aligned} \quad (\text{viii})$$

and

$$\begin{aligned} [\mathbf{U}^{-1}]_{\mathbf{e}_i} &= \begin{bmatrix} 0.3827 & 0.9238 & 0 \\ 0.9238 & -0.3827 & 0 \\ 0 & 0 & 1 \end{bmatrix} \begin{bmatrix} 0.4142 & 0 & 0 \\ 0 & 2.414 & 0 \\ 0 & 0 & 1 \end{bmatrix} \begin{bmatrix} 0.3827 & 0.9238 & 0 \\ 0.9238 & -0.3827 & 0 \\ 0 & 0 & 1 \end{bmatrix} \\ &= \begin{bmatrix} 2.121 & -0.7070 & 0 \\ -0.7070 & 0.7070 & 0 \\ 0 & 0 & 1 \end{bmatrix}. \end{aligned} \quad (\text{ix})$$

$$(\text{e}) \quad [\mathbf{R}]_{\mathbf{e}_i} = [\mathbf{F}][\mathbf{U}^{-1}] = \begin{bmatrix} 1 & 2 & 0 \\ 0 & 1 & 0 \\ 0 & 0 & 1 \end{bmatrix} \begin{bmatrix} 2.121 & -0.7070 & 0 \\ -0.7070 & 0.7070 & 0 \\ 0 & 0 & 1 \end{bmatrix} = \begin{bmatrix} 0.707 & 0.707 & 0 \\ -0.707 & 0.707 & 0 \\ 0 & 0 & 1 \end{bmatrix}. \quad (\text{x})$$

Example 3.23.2

Consider the simple shear deformation given by (see Figure 3.23-1)

$$x_1 = X_1 + kX_2, \quad x_2 = X_2, \quad x_3 = X_3.$$

- (a) What is the stretch for an element that was in the direction of \mathbf{e}_1 ?
 (b) What is the stretch for an element that was in the direction of \mathbf{e}_2 ?

- (c) What is the stretch for an element that was in the direction of $\mathbf{e}_1 + \mathbf{e}_2$?
 (d) In the deformed configuration, what is the angle between the two elements that were in the directions of \mathbf{e}_1 and \mathbf{e}_2 ?

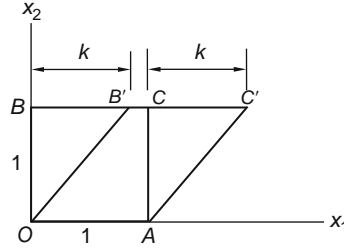

FIGURE 3.23-1

Solution

$$[\mathbf{F}] = \begin{bmatrix} 1 & k & 0 \\ 0 & 1 & 0 \\ 0 & 0 & 1 \end{bmatrix}, \quad [\mathbf{C}] = [\mathbf{F}]^T [\mathbf{F}] = \begin{bmatrix} 1 & 0 & 0 \\ k & 1 & 0 \\ 0 & 0 & 1 \end{bmatrix} \begin{bmatrix} 1 & k & 0 \\ 0 & 1 & 0 \\ 0 & 0 & 1 \end{bmatrix} = \begin{bmatrix} 1 & k & 0 \\ k & 1+k^2 & 0 \\ 0 & 0 & 1 \end{bmatrix}$$

- (a) For $d\mathbf{X}^{(1)} = dS_1 \mathbf{e}_1$, $ds_1/dS_1 = 1$.
 (b) For $d\mathbf{X}^{(2)} = dS_2 \mathbf{e}_2$, $ds_2/dS_2 = \sqrt{1+k^2}$.
 (c) For $d\mathbf{X} = (dS/\sqrt{2})(\mathbf{e}_1 + \mathbf{e}_2) = dS \mathbf{e}'_1$.

$$\left(\frac{ds}{dS}\right)^2 = C'_{11} = \frac{1}{2} [1, 1, 0] \begin{bmatrix} 1 & k & 0 \\ k & 1+k^2 & 0 \\ 0 & 0 & 1 \end{bmatrix} \begin{bmatrix} 1 \\ 1 \\ 0 \end{bmatrix} = 1 + k + \frac{k^2}{2}, \quad \text{thus,} \quad \frac{ds}{dS} = \sqrt{1 + k + \frac{k^2}{2}}$$

- (d) For $d\mathbf{X}^{(1)} = dS_1 \mathbf{e}_1$ and $d\mathbf{X}^{(2)} = dS_2 \mathbf{e}_2$, from Eq. (3.23.10) and the results in (a) and (b),

$$\cos(d\mathbf{x}^{(1)}, d\mathbf{x}^{(2)}) = \frac{dS_1 dS_2}{ds_1 ds_2} C_{12} = \frac{k}{\sqrt{1+k^2}}.$$

Example 3.23.3

Show that (a) the eigenvectors of \mathbf{U} and \mathbf{C} are the same and (b) an element that was in the principal direction \mathbf{n} of \mathbf{C} becomes, in the deformed state, an element in the direction of \mathbf{Rn} .

Solution

- (a) $\mathbf{U}\mathbf{n} = \lambda\mathbf{n}$; therefore, $\mathbf{U}^2\mathbf{n} = \lambda\mathbf{U}\mathbf{n} = \lambda^2\mathbf{n}$, i.e.,

$$\mathbf{C}\mathbf{n} = \lambda^2\mathbf{n}.$$

Thus, \mathbf{n} is also an eigenvector of \mathbf{C} with λ^2 as its eigenvalue.

(b) If $d\mathbf{X} = dS\mathbf{n}$, where \mathbf{n} is a principal direction of \mathbf{U} and \mathbf{C} , then $\mathbf{U}d\mathbf{X} = dS\mathbf{U}\mathbf{n} = dS\lambda\mathbf{n}$ so that

$$d\mathbf{x} = \mathbf{F}d\mathbf{X} = \mathbf{R}\mathbf{U}d\mathbf{X} = \lambda dS(\mathbf{R}\mathbf{n}).$$

That is, the deformed vector is in the direction of $\mathbf{R}\mathbf{n}$.

3.24 LAGRANGIAN STRAIN TENSOR

Let

$$\mathbf{E}^* = \frac{1}{2}(\mathbf{C} - \mathbf{I}), \quad (3.24.1)$$

where \mathbf{C} is the right Cauchy-Green deformation tensor and \mathbf{I} is the identity tensor. The tensor \mathbf{E}^* is known as the *Lagrangian finite strain tensor*. We note that if there is no deformation, $\mathbf{C} = \mathbf{I}$ and $\mathbf{E}^* = \mathbf{0}$.

From Eq. (3.23.4), we have

$$d\mathbf{x}^{(1)} \cdot d\mathbf{x}^{(2)} - d\mathbf{X}^{(1)} \cdot d\mathbf{X}^{(2)} = d\mathbf{X}^{(1)} \cdot (\mathbf{C} - \mathbf{I})d\mathbf{X}^{(2)}, \quad (3.24.2)$$

i.e.,

$$d\mathbf{x}^{(1)} \cdot d\mathbf{x}^{(2)} - d\mathbf{X}^{(1)} \cdot d\mathbf{X}^{(2)} = 2d\mathbf{X}^{(1)} \cdot \mathbf{E}^*d\mathbf{X}^{(2)}. \quad (3.24.3)$$

For a material element $d\mathbf{X} = dS_1\mathbf{e}_1$ deforming into $d\mathbf{x} = ds_1\mathbf{n}$, where \mathbf{n} is a unit vector, Eq. (3.24.3), with $d\mathbf{X}^{(1)} = d\mathbf{X}^{(2)} = d\mathbf{X} = dS_1\mathbf{e}_1$ and $d\mathbf{x}^{(1)} = d\mathbf{x}^{(2)} = d\mathbf{x} = ds_1\mathbf{n}$, gives

$$ds_1^2 - dS_1^2 = 2dS_1^2\mathbf{e}_1 \cdot \mathbf{E}^*\mathbf{e}_1. \quad (3.24.4)$$

Thus,

$$E_{11}^* = \frac{ds_1^2 - dS_1^2}{2dS_1^2} \quad \text{for } d\mathbf{X} = dS_1\mathbf{e}_1 \text{ deforming into } d\mathbf{x} = ds_1\mathbf{n}. \quad (3.24.5)$$

Similarly,

$$E_{22}^* = \frac{ds_2^2 - dS_2^2}{2dS_2^2} \quad \text{for } d\mathbf{X} = dS_2\mathbf{e}_2 \text{ deforming into } d\mathbf{x} = ds_2\mathbf{m}, \quad (3.24.6)$$

and

$$E_{33}^* = \frac{ds_3^2 - dS_3^2}{2dS_3^2} \quad \text{for } d\mathbf{X} = dS_3\mathbf{e}_3 \text{ deforming into } d\mathbf{x} = ds_3\mathbf{q}, \quad (3.24.7)$$

where \mathbf{n} , \mathbf{m} and \mathbf{q} are unit vectors, not mutually perpendicular in general. They are mutually perpendicular if $\{\mathbf{e}_1, \mathbf{e}_2, \mathbf{e}_3\}$ are eigenvectors of \mathbf{E}^* .

By considering two material elements $d\mathbf{X}^{(1)} = dS_1\mathbf{e}_1$ and $d\mathbf{X}^{(2)} = dS_2\mathbf{e}_2$, deforming into $d\mathbf{x}^{(1)} = ds_1\mathbf{n}$ and $d\mathbf{x}^{(2)} = ds_2\mathbf{m}$, then Eq. (3.24.3) gives

$$ds_1ds_2 \cos(\mathbf{dx}^{(1)}, \mathbf{dx}^{(2)}) = 2dS_1dS_2\mathbf{e}_1 \cdot \mathbf{E}^*\mathbf{e}_2. \quad (3.24.8)$$

That is,

$$2\mathbf{E}_{12}^* = \frac{ds_1 ds_2}{dS_1 dS_2} \cos(\mathbf{n}, \mathbf{m}). \quad (3.24.9)$$

The meanings for $2E_{13}^*$ and $2E_{23}^*$ can be established in a similar manner.

We can also express the components of \mathbf{E}^* in terms of the displacement components. From $\mathbf{C} = \mathbf{F}^T \mathbf{F}$ and $\mathbf{F} = \mathbf{I} + \nabla \mathbf{u}$, Eq. (3.24.1) leads to

$$\mathbf{E}^* = \frac{1}{2}(\mathbf{F}^T \mathbf{F} - \mathbf{I}) = \frac{1}{2} [\nabla \mathbf{u} + (\nabla \mathbf{u})^T] + \frac{1}{2} (\nabla \mathbf{u})^T (\nabla \mathbf{u}). \quad (3.24.10)$$

In indicial notation, we have

$$E_{ij}^* = \frac{1}{2} \left(\frac{\partial u_i}{\partial X_j} + \frac{\partial u_j}{\partial X_i} \right) + \frac{1}{2} \frac{\partial u_m}{\partial X_i} \frac{\partial u_m}{\partial X_j}, \quad (3.24.11)$$

and in long form,

$$E_{11}^* = \frac{\partial u_1}{\partial X_1} + \frac{1}{2} \left[\left(\frac{\partial u_1}{\partial X_1} \right)^2 + \left(\frac{\partial u_2}{\partial X_1} \right)^2 + \left(\frac{\partial u_3}{\partial X_1} \right)^2 \right], \quad (3.24.12)$$

$$E_{12}^* = \frac{1}{2} \left(\frac{\partial u_1}{\partial X_2} + \frac{\partial u_2}{\partial X_1} \right) + \frac{1}{2} \left[\left(\frac{\partial u_1}{\partial X_1} \right) \left(\frac{\partial u_1}{\partial X_2} \right) + \left(\frac{\partial u_2}{\partial X_1} \right) \left(\frac{\partial u_2}{\partial X_2} \right) + \left(\frac{\partial u_3}{\partial X_1} \right) \left(\frac{\partial u_3}{\partial X_2} \right) \right], \quad (3.24.13)$$

and so on. We note that for small values of displacement gradients, these equations reduce to those of the infinitesimal strain tensor.

Example 3.24.1

For the simple shear deformation

$$x_1 = X_1 + kX_2, \quad x_2 = X_2, \quad x_3 = X_3$$

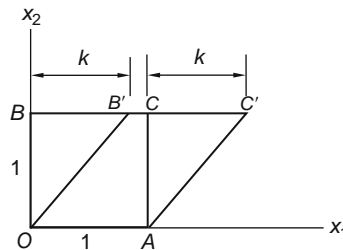

FIGURE 3.24-1

- Compute the Lagrangian strain tensor \mathbf{E}^* .
- Referring to Figure 3.24-1, by a simple geometric consideration, find the deformed length of the element OB .
- Compare the results of (b) with E_{22}^* .

Solution

(a) Using the $[C]$ obtained in Example 3.23.2, we easily obtain from the equation $2E^* = C - I$

$$[E^*] = \frac{1}{2} \left(\begin{bmatrix} 1 & k & 0 \\ k & 1+k^2 & 0 \\ 0 & 0 & 1 \end{bmatrix} - [I] \right) = \begin{bmatrix} 0 & k/2 & 0 \\ k/2 & k^2/2 & 0 \\ 0 & 0 & 0 \end{bmatrix}.$$

(b) From Figure 3.24-1, we see from geometry that $OB' = \sqrt{1+k^2}$.

(c) We have $E_{22}^* = k^2/2$; thus,

$$\frac{(\Delta s)^2 - (\Delta S)^2}{2(\Delta S)^2} = \frac{k^2}{2}.$$

Thus, with $\Delta S = OB = 1$ and $\Delta s = OB'$, we have

$$OB' = (\Delta s) = (\Delta S)\sqrt{1+k^2} = \sqrt{1+k^2}.$$

This is the same result as in (b). We note that if k is very small, then $OB' = OB$ to the first order of k .

Example 3.24.2

Consider the displacement components corresponding to a uniaxial strain field:

$$u_1 = kX_1, \quad u_2 = u_3 = 0. \tag{i}$$

- (a) Calculate both the Lagrangian strain tensor E^* and the infinitesimal strain tensor E .
- (b) Use the finite strain component E_{11}^* and the infinitesimal strain component E_{11} to calculate $(\Delta s/\Delta S)$ for the element $\Delta X = \Delta S e_1$.
- (c) For an element $\Delta X = \Delta S(e_1 + e_2)/\sqrt{2}$, calculate $(\Delta s/\Delta S)$ from both the finite strain tensor E^* and the infinitesimal strain tensor E .

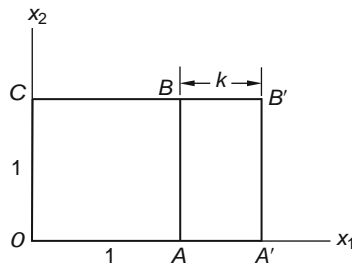

FIGURE 3.24-2

Solution

$$(a) \quad [\mathbf{E}] = [(\nabla \mathbf{u})^S] = \begin{bmatrix} k & 0 & 0 \\ 0 & 0 & 0 \\ 0 & 0 & 0 \end{bmatrix}, \text{ and } [\mathbf{E}^*] = [(\nabla \mathbf{u})^S] + \frac{1}{2} [\nabla \mathbf{u}]^T [\nabla \mathbf{u}] = \begin{bmatrix} k + (k^2/2) & 0 & 0 \\ 0 & 0 & 0 \\ 0 & 0 & 0 \end{bmatrix}. \quad (ii)$$

(b) Based on $E_{11}^* = k + \frac{k^2}{2}$, we have $\frac{(\Delta s)^2 - (\Delta S)^2}{2(\Delta S)^2} = k + \frac{k^2}{2}$; therefore, $(\Delta s)^2 = (\Delta S)^2(1 + 2k + k^2)$.
That is,

$$\Delta s = \Delta S(1 + k). \quad (iii)$$

On the other hand, based on $E_{11} = k$, $\frac{\Delta s - \Delta S}{\Delta S} = k$, therefore, in this case, the infinitesimal theory also gives

$$\Delta s = \Delta S(1 + k). \quad (iv)$$

This is confirmed by the geometry shown in Figure 3.24-2.

(c) Let $\mathbf{e}'_1 = \frac{1}{\sqrt{2}}(\mathbf{e}_1 + \mathbf{e}_2)$; then

$$E_{11}^{t*} = \frac{1}{2} [1, 1, 0] \begin{bmatrix} k + k^2/2 & 0 & 0 \\ 0 & 0 & 0 \\ 0 & 0 & 0 \end{bmatrix} \begin{bmatrix} 1 \\ 1 \\ 0 \end{bmatrix} = \frac{k}{2} + \frac{k^2}{4} = \frac{(\Delta s)^2 - (\Delta S)^2}{2(\Delta S)^2}. \quad (v)$$

Thus,

$$\Delta s = \Delta S \sqrt{1 + k + k^2/2}. \quad (vi)$$

This result is easily confirmed by the geometry in Figure 3.24-2, where we see that the diagonal length of OB changes from $\Delta S = \sqrt{2}$ to $\Delta s = \sqrt{(1+k)^2 + 1} = \sqrt{2} \sqrt{1 + k + k^2/2}$ (length of OB') so that $\Delta s = \Delta S \sqrt{1 + k + k^2/2}$, as in the previous equation.

On the other hand, using the infinitesimal tensor, we have $E'_{11} = \mathbf{e}'_1 \cdot \mathbf{E} \mathbf{e}'_1 = k/2$, so that

$$\Delta s = [1 + (k/2)] \Delta S. \quad (vii)$$

We note that, for small k , $\sqrt{1 + k + k^2/2} \approx 1 + (1/2)(k + k^2/2) + \dots \approx 1 + (k/2)$ so that Eq. (vi) reduces to Eq. (vii).

3.25 LEFT CAUCHY-GREEN DEFORMATION TENSOR

Let

$$\mathbf{B} = \mathbf{V}^2, \quad (3.25.1)$$

where \mathbf{V} is the left stretch tensor. The tensor \mathbf{B} is known as the *left Cauchy-Green deformation tensor* (also known as *Finger deformation tensor*). We note that if there is no deformation, $\mathbf{V} = \mathbf{B} = \mathbf{U} = \mathbf{C} = \mathbf{I}$.

From $\mathbf{F} = \mathbf{VR}$ [Eq. (3.21.2)], it can be easily verified that

$$\mathbf{B} = \mathbf{FF}^T. \quad (3.25.2)$$

Substituting $\mathbf{F} = \mathbf{R}\mathbf{U}$ in Eq. (3.25.2), we obtain the relations between \mathbf{B} and \mathbf{C} as follows:

$$\mathbf{B} = \mathbf{R}\mathbf{C}\mathbf{R}^T \quad \text{and} \quad \mathbf{C} = \mathbf{R}^T\mathbf{B}\mathbf{R}. \quad (3.25.3)$$

We also note that if \mathbf{n} is an eigenvector of \mathbf{C} with eigenvalue λ , then $\mathbf{R}\mathbf{n}$ is an eigenvector of \mathbf{B} with the same eigenvalue λ .

The components of \mathbf{B} have very simple geometric meanings, which we describe here.

Consider a material element $d\mathbf{X} = dS\mathbf{n}$, where $\mathbf{n} = \mathbf{R}^T\mathbf{e}_1$, \mathbf{R} being the rotation tensor, associated with the deformation gradient \mathbf{F} , which deforms $d\mathbf{X} = dS\mathbf{n}$ into $d\mathbf{x} = dsm$, where \mathbf{m} is a unit vector. From Eq. (3.23.4),

$$ds^2 = dS^2\mathbf{n} \cdot \mathbf{C}\mathbf{n} = dS^2\mathbf{R}^T\mathbf{e}_1 \cdot \mathbf{C}\mathbf{R}^T\mathbf{e}_1 = dS^2\mathbf{e}_1 \cdot \mathbf{R}\mathbf{C}\mathbf{R}^T\mathbf{e}_1, \quad (3.25.4)$$

that is,

$$ds^2 = dS^2\mathbf{e}_1 \cdot \mathbf{B}\mathbf{e}_1 \quad \text{for} \quad d\mathbf{X} = dS(\mathbf{R}^T\mathbf{e}_1). \quad (3.25.5)$$

Thus,

$$B_{11} = \left(\frac{ds_1}{dS_1}\right)^2 \quad \text{for a material element} \quad d\mathbf{X} = dS_1(\mathbf{R}^T\mathbf{e}_1). \quad (3.25.6)$$

Similarly,

$$B_{22} = \left(\frac{ds_2}{dS_2}\right)^2 \quad \text{for a material element} \quad d\mathbf{X} = dS_2(\mathbf{R}^T\mathbf{e}_2), \quad (3.25.7)$$

and

$$B_{33} = \left(\frac{ds_3}{dS_3}\right)^2 \quad \text{for a material element} \quad d\mathbf{X} = dS_3(\mathbf{R}^T\mathbf{e}_3). \quad (3.25.8)$$

Next, consider two material elements $d\mathbf{X}^{(1)} = dS_1\mathbf{R}^T\mathbf{e}_1$ and $d\mathbf{X}^{(2)} = dS_2\mathbf{R}^T\mathbf{e}_2$, which deform into $d\mathbf{x}^{(1)} = ds_1\mathbf{m}$ and $d\mathbf{x}^{(2)} = ds_2\mathbf{n}$, where \mathbf{m} and \mathbf{n} are unit vectors having an angle of β between them; then Eq. (3.23.4) gives

$$ds_1ds_2 \cos \beta = dS_1dS_2\mathbf{R}^T\mathbf{e}_1 \cdot \mathbf{C}(\mathbf{R}^T\mathbf{e}_2) = dS_1dS_2\mathbf{e}_1 \cdot \mathbf{R}\mathbf{C}\mathbf{R}^T\mathbf{e}_2 = dS_1dS_2\mathbf{e}_1 \cdot \mathbf{B}\mathbf{e}_2, \quad (3.25.9)$$

that is,

$$B_{12} = \frac{ds_1ds_2}{dS_1dS_2} \cos(d\mathbf{x}^{(1)}, d\mathbf{x}^{(2)}) \quad \text{for} \quad d\mathbf{X}^{(1)} = dS_1(\mathbf{R}^T\mathbf{e}_1) \quad \text{and} \quad d\mathbf{X}^{(2)} = dS_2(\mathbf{R}^T\mathbf{e}_2). \quad (3.25.10)$$

Similarly,

$$B_{13} = \frac{ds_1ds_3}{dS_1dS_3} \cos(d\mathbf{x}^{(1)}, d\mathbf{x}^{(3)}) \quad \text{for} \quad d\mathbf{X}^{(1)} = dS_1(\mathbf{R}^T\mathbf{e}_1) \quad \text{and} \quad d\mathbf{X}^{(3)} = dS_3(\mathbf{R}^T\mathbf{e}_3), \quad (3.25.11)$$

and

$$B_{23} = \frac{ds_2ds_3}{dS_2dS_3} \cos(d\mathbf{x}^{(2)}, d\mathbf{x}^{(3)}) \quad \text{for} \quad d\mathbf{X}^{(2)} = dS_2(\mathbf{R}^T\mathbf{e}_2) \quad \text{and} \quad d\mathbf{X}^{(3)} = dS_3(\mathbf{R}^T\mathbf{e}_3). \quad (3.25.12)$$

We can also express the components of \mathbf{B} in terms of the displacement components. Using Eq. (3.18.5), we have

$$\mathbf{B} = \mathbf{F}\mathbf{F}^T = (\mathbf{I} + \nabla\mathbf{u})(\mathbf{I} + \nabla\mathbf{u})^T = \mathbf{I} + \nabla\mathbf{u} + (\nabla\mathbf{u})^T + (\nabla\mathbf{u})(\nabla\mathbf{u})^T. \quad (3.25.13)$$

In indicial notation, we have

$$B_{ij} = \delta_{ij} + \left(\frac{\partial u_i}{\partial X_j} + \frac{\partial u_j}{\partial X_i}\right) + \left(\frac{\partial u_i}{\partial X_m}\right)\left(\frac{\partial u_j}{\partial X_m}\right). \quad (3.25.14)$$

We note that for small displacement gradients, $\frac{1}{2}(B_{ij} - \delta_{ij}) = E_{ij}$.

Example 3.25.1

For the simple shear deformation

$$x_1 = X_1 + kX_2, \quad x_2 = X_2, \quad x_3 = X_3. \quad (3.25.15)$$

- (a) Obtain the Cauchy-Green deformation tensor \mathbf{C} and \mathbf{B} .
 (b) Use the relation $\mathbf{B} = \mathbf{R}\mathbf{C}\mathbf{R}^T$ to verify that for this simple shear deformation:

$$[\mathbf{R}] = \frac{1}{\sqrt{1+k^2/4}} \begin{bmatrix} 1 & k/2 & 0 \\ -k/2 & 1 & 0 \\ 0 & 0 & \sqrt{1+k^2/4} \end{bmatrix}. \quad (3.25.16)$$

- (c) Verify that

$$[\mathbf{U}] = \frac{1}{\sqrt{1+k^2/4}} \begin{bmatrix} 1 & k/2 & 0 \\ k/2 & 1+k^2/2 & 0 \\ 0 & 0 & \sqrt{1+k^2/4} \end{bmatrix}.$$

- (d) Calculate $\mathbf{R}^T\mathbf{e}_1$ and $\mathbf{R}^T\mathbf{e}_2$.
 (e) Sketch both the undeformed and the deformed position for the element $\mathbf{R}^T\mathbf{e}_1$ and the element $\mathbf{R}^T\mathbf{e}_2$. Calculate the stretches for these two elements from the geometry in the figure and compare it with B_{11} and B_{22} .

Solution

- (a) We have

$$[\mathbf{F}] = \begin{bmatrix} 1 & k & 0 \\ 0 & 1 & 0 \\ 0 & 0 & 1 \end{bmatrix}. \quad (3.25.17)$$

Thus,

$$[\mathbf{C}] = [\mathbf{F}^T\mathbf{F}] = \begin{bmatrix} 1 & 0 & 0 \\ k & 1 & 0 \\ 0 & 0 & 1 \end{bmatrix} \begin{bmatrix} 1 & k & 0 \\ 0 & 1 & 0 \\ 0 & 0 & 1 \end{bmatrix} = \begin{bmatrix} 1 & k & 0 \\ k & 1+k^2 & 0 \\ 0 & 0 & 1 \end{bmatrix}, \quad (3.25.18)$$

$$[\mathbf{B}] = [\mathbf{F}\mathbf{F}^T] = \begin{bmatrix} 1 & k & 0 \\ 0 & 1 & 0 \\ 0 & 0 & 1 \end{bmatrix} \begin{bmatrix} 1 & 0 & 0 \\ k & 1 & 0 \\ 0 & 0 & 1 \end{bmatrix} = \begin{bmatrix} 1+k^2 & k & 0 \\ k & 1 & 0 \\ 0 & 0 & 1 \end{bmatrix}. \quad (3.25.19)$$

(b) Using Eq. (3.25.16), we have

$$\begin{aligned}
 [\mathbf{R}][\mathbf{C}][\mathbf{R}]^T &= \frac{1}{\sqrt{1+k^2/4}} \times \frac{1}{\sqrt{1+k^2/4}} \\
 &\times \begin{bmatrix} 1 & k/2 & 0 \\ -k/2 & 1 & 0 \\ 0 & 0 & \sqrt{1+k^2/4} \end{bmatrix} \begin{bmatrix} 1 & k & 0 \\ k & 1+k^2 & 0 \\ 0 & 0 & 1 \end{bmatrix} \begin{bmatrix} 1 & -k/2 & 0 \\ k/2 & 1 & 0 \\ 0 & 0 & \sqrt{1+k^2/4} \end{bmatrix} \\
 &= \frac{1}{(1+k^2/4)} \begin{bmatrix} (1+k^2)(1+k^2/4) & k(1+k^2/4) & 0 \\ k(1+k^2/4) & (1+k^2/4) & 0 \\ 0 & 0 & (1+k^2/4) \end{bmatrix} = \begin{bmatrix} (1+k^2) & k & 0 \\ k & 1 & 0 \\ 0 & 0 & 1 \end{bmatrix}.
 \end{aligned}$$

Thus, for the given \mathbf{R} , we have $[\mathbf{R}][\mathbf{C}][\mathbf{R}]^T = [\mathbf{B}]$.

(c) For the given $[\mathbf{U}]$,

$$\begin{aligned}
 [\mathbf{U}]^2 &= \frac{1}{1+k^2/4} \begin{bmatrix} 1 & k/2 & 0 \\ k/2 & 1+k^2/2 & 0 \\ 0 & 0 & \sqrt{1+k^2/4} \end{bmatrix} \begin{bmatrix} 1 & k/2 & 0 \\ k/2 & 1+k^2/2 & 0 \\ 0 & 0 & \sqrt{1+k^2/4} \end{bmatrix} \\
 &= \frac{1}{1+k^2/4} \begin{bmatrix} 1+k^2/4 & k(1+k^2/4) & 0 \\ k(1+k^2/4) & (1+k^2)(1+k^2/4) & 0 \\ 0 & 0 & (1+k^2/4) \end{bmatrix} = \begin{bmatrix} 1 & k & 0 \\ k & 1+k^2 & 0 \\ 0 & 0 & 1 \end{bmatrix} = [\mathbf{C}].
 \end{aligned}$$

Thus, $[\mathbf{U}]$ is the stretch tensor.

(d) $\mathbf{R}^T \mathbf{e}_1 = [\mathbf{e}_1 + (k/2)\mathbf{e}_2]d$, and $\mathbf{R}^T \mathbf{e}_2 = [(-k/2)\mathbf{e}_1 + \mathbf{e}_2]d$, where $d = 1/\sqrt{1+k^2/4}$.

(e) Referring to Figure 3.25-1, $\mathbf{R}^T \mathbf{e}_2$ is depicted by OE . After deformation, it becomes OE' ; the distance between E and E' is kd , which is $2(kd/2)$ so that OE' is the mirror image (with respect to the line OB) of OE and has the same length as OE . Thus, from geometry, the stretch for this element is unity. This checks with the value of B_{22} , which is also unity. Also, in the same figure, OG is the vector $\mathbf{R}^T \mathbf{e}_1$. After deformation, it becomes OG' . The square of the length of OG' is

$$\begin{aligned}
 (ds)^2 &= (d + k^2 d/2)^2 + (kd/2)^2 = d^2[(1 + k^2/2)^2 + k^2/4] \\
 &= d^2(1 + k^2 + k^4/4 + k^2/4) = d^2(1 + k^2)(1 + k^2/4) = (1 + k^2),
 \end{aligned}$$

and the length of $\mathbf{R}^T \mathbf{e}_1$ is $dS = 1$; therefore, $(ds/dS)^2 = 1 + k^2$, which is the same as B_{11} .

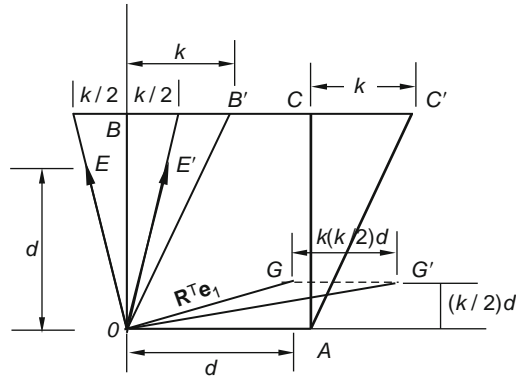

FIGURE 3.25-1

3.26 EULERIAN STRAIN TENSOR

Let

$$\mathbf{e}^* = \frac{1}{2}(\mathbf{I} - \mathbf{B}^{-1}), \quad (3.26.1)$$

where $\mathbf{B} = \mathbf{F}\mathbf{F}^T$ is the left Cauchy-Green deformation tensor. The tensor \mathbf{e}^* is known as the *Eulerian strain tensor*. We note that if there is no deformation, $\mathbf{B}^{-1} = \mathbf{I}$ and $\mathbf{e}^* = 0$.

The geometric meaning of the component of \mathbf{e}^* and \mathbf{B}^{-1} are described here.

From $d\mathbf{x} = \mathbf{F}d\mathbf{X}$, we have

$$d\mathbf{X} = \mathbf{F}^{-1}d\mathbf{x}, \quad (3.26.2)$$

where \mathbf{F}^{-1} is the inverse of \mathbf{F} . In rectangular Cartesian coordinates, Eq. (3.26.2) reads

$$dX_i = F_{ij}^{-1}dx_j. \quad (3.26.3)$$

Thus,

$$F_{ij}^{-1} = \frac{\partial X_i}{\partial x_j}, \quad (3.26.4)$$

where $X_i = X_i(x_1, x_2, x_3, t)$ is the inverse of $x_i = x_i(X_1, X_2, X_3, t)$. In other words, when rectangular Cartesian coordinates are used for both the reference and the current configuration,

$$[\mathbf{F}^{-1}] = \begin{bmatrix} \frac{\partial X_1}{\partial x_1} & \frac{\partial X_1}{\partial x_2} & \frac{\partial X_1}{\partial x_3} \\ \frac{\partial X_2}{\partial x_1} & \frac{\partial X_2}{\partial x_2} & \frac{\partial X_2}{\partial x_3} \\ \frac{\partial X_3}{\partial x_1} & \frac{\partial X_3}{\partial x_2} & \frac{\partial X_3}{\partial x_3} \end{bmatrix}. \quad (3.26.5)$$

Now,

$$d\mathbf{X}^{(1)} \cdot d\mathbf{X}^{(2)} = \mathbf{F}^{-1} d\mathbf{x}^{(1)} \cdot \mathbf{F}^{-1} d\mathbf{x}^{(2)} = d\mathbf{x}^{(1)} \cdot (\mathbf{F}^{-1})^T \mathbf{F}^{-1} d\mathbf{x}^{(2)} = d\mathbf{x}^{(1)} \cdot (\mathbf{F}\mathbf{F}^T)^{-1} d\mathbf{x}^{(2)},$$

i.e.,

$$d\mathbf{X}^{(1)} \cdot d\mathbf{X}^{(2)} = d\mathbf{x}^{(1)} \cdot \mathbf{B}^{-1} d\mathbf{x}^{(2)}, \quad (3.26.6)$$

and

$$d\mathbf{x}^{(1)} \cdot d\mathbf{x}^{(2)} - d\mathbf{X}^{(1)} \cdot d\mathbf{X}^{(2)} = d\mathbf{x}^{(1)} \cdot (\mathbf{I} - \mathbf{B}^{-1}) d\mathbf{x}^{(2)}, \quad (3.26.7)$$

that is,

$$d\mathbf{x}^{(1)} \cdot d\mathbf{x}^{(2)} - d\mathbf{X}^{(1)} \cdot d\mathbf{X}^{(2)} = 2d\mathbf{x}^{(1)} \cdot \mathbf{e}^* d\mathbf{x}^{(2)}. \quad (3.26.8)$$

Thus, if we consider a material element, which at time t is in the direction of \mathbf{e}_1 , i.e., $d\mathbf{x} = ds\mathbf{e}_1$, and which at the reference time is $d\mathbf{X} = dS\mathbf{n}$, where \mathbf{n} is a unit vector, then Eqs. (3.26.6) and (3.26.8) give

$$\frac{dS^2}{ds^2} = \mathbf{e}_1 \cdot \mathbf{B}^{-1} \mathbf{e}_1 = B_{11}^{-1}, \quad (3.26.9)$$

and

$$\frac{ds^2 - dS^2}{2ds^2} = \mathbf{e}_1 \cdot \mathbf{e}^* \mathbf{e}_1 = \mathbf{e}_{11}^*, \quad (3.26.10)$$

respectively. Similar meanings hold for the other diagonal elements of \mathbf{B}^{-1} and \mathbf{e}^* .

By considering two material elements $d\mathbf{x}^{(1)} = ds_1\mathbf{e}_1$ and $d\mathbf{x}^{(2)} = ds_2\mathbf{e}_2$ at time t corresponding to $d\mathbf{X}^{(1)} = dS_1\mathbf{n}$ and $d\mathbf{X}^{(2)} = dS_2\mathbf{m}$ at the reference time, where \mathbf{n} and \mathbf{m} are unit vectors, Eqs. (3.26.6) and (3.26.8) give

$$\frac{dS_1 dS_2}{ds_1 ds_2} \cos(\mathbf{n}, \mathbf{m}) = \mathbf{e}_1 \cdot \mathbf{B}^{-1} \mathbf{e}_2 = B_{12}^{-1}, \quad (3.26.11)$$

and

$$-\frac{ds_1 ds_2}{2ds_1 ds_2} \cos(\mathbf{n}, \mathbf{m}) = \mathbf{e}_{12}^*, \quad (3.26.12)$$

respectively.

We can also express \mathbf{B}^{-1} and \mathbf{e}^* in terms of the displacement components. From $\mathbf{u} = \mathbf{x} - \mathbf{X}$, we can write

$$\mathbf{X} = \mathbf{x} - \mathbf{u}(x_1, x_2, x_3, t) \quad \text{or} \quad X_i = x_i - u_i(x_1, x_2, x_3, t), \quad (3.26.13)$$

where we have used the spatial description of the displacement field because we intend to differentiate this equation with respect to the spatial coordinates x_i . Thus, from Eq. (3.26.13), we have

$$\frac{\partial X_i}{\partial x_j} = \delta_{ij} - \frac{\partial u_i}{\partial x_j} \quad \text{or} \quad \mathbf{F}^{-1} = \mathbf{I} - \nabla_{\mathbf{x}} \mathbf{u}, \quad (3.26.14)$$

therefore, from $\mathbf{B}^{-1} = (\mathbf{F}\mathbf{F}^T)^{-1} = (\mathbf{F}^{-1})^T \mathbf{F}^{-1}$, and $\mathbf{e}^* = (1/2)(\mathbf{I} - \mathbf{B}^{-1})$, we get

$$\mathbf{B}^{-1} = [\mathbf{I} - (\nabla_{\mathbf{x}} \mathbf{u})^T] [\mathbf{I} - (\nabla_{\mathbf{x}} \mathbf{u})] = \mathbf{I} - [(\nabla_{\mathbf{x}} \mathbf{u})^T + (\nabla_{\mathbf{x}} \mathbf{u})] + (\nabla_{\mathbf{x}} \mathbf{u})^T (\nabla_{\mathbf{x}} \mathbf{u}), \quad (3.26.15)$$

and

$$\mathbf{e}^* = \frac{(\nabla_{\mathbf{x}}\mathbf{u}) + (\nabla_{\mathbf{x}}\mathbf{u})^T}{2} - \frac{(\nabla_{\mathbf{x}}\mathbf{u})^T(\nabla_{\mathbf{x}}\mathbf{u})}{2}. \quad (3.26.16)$$

In indicial notation, Eq. (3.26.16) reads

$$e_{ij}^* = \frac{1}{2} \left(\frac{\partial u_i}{\partial x_j} + \frac{\partial u_j}{\partial x_i} \right) - \frac{1}{2} \frac{\partial u_m}{\partial x_i} \frac{\partial u_m}{\partial x_j}, \quad (3.26.17)$$

and in long form,

$$e_{11}^* = \frac{\partial u_1}{\partial x_1} - \frac{1}{2} \left[\left(\frac{\partial u_1}{\partial x_1} \right)^2 + \left(\frac{\partial u_2}{\partial x_1} \right)^2 + \left(\frac{\partial u_3}{\partial x_1} \right)^2 \right], \quad (3.26.18)$$

$$e_{12}^* = \frac{1}{2} \left(\frac{\partial u_1}{\partial x_2} + \frac{\partial u_2}{\partial x_1} \right) - \frac{1}{2} \left[\frac{\partial u_1}{\partial x_1} \frac{\partial u_1}{\partial x_2} + \frac{\partial u_2}{\partial x_1} \frac{\partial u_2}{\partial x_2} + \frac{\partial u_3}{\partial x_1} \frac{\partial u_3}{\partial x_2} \right]. \quad (3.26.19)$$

The other components can be similarly written. We note that for infinitesimal deformation, $\frac{\partial u_i}{\partial x_j} \approx \frac{\partial u_i}{\partial X_j}$ and products of the gradients are negligible, Eq. (3.26.17) becomes the same as Eq. (3.7.16).

Example 3.26.1

For the simple shear deformation

$$x_1 = X_1 + kX_2, \quad x_2 = X_2, \quad x_3 = X_3. \quad (i)$$

(a) Find \mathbf{B}^{-1} and \mathbf{e}^* .

(b) Use the geometry in Figure 3.26-1 to discuss the meaning of e_{11}^* and e_{22}^* .

Solution

$$(a) \quad [\mathbf{F}] = \begin{bmatrix} 1 & k & 0 \\ 0 & 1 & 0 \\ 0 & 0 & 1 \end{bmatrix} \quad \text{and} \quad [\mathbf{F}^{-1}] = \begin{bmatrix} 1 & -k & 0 \\ 0 & 1 & 0 \\ 0 & 0 & 1 \end{bmatrix}, \quad (ii)$$

$$[\mathbf{B}^{-1}] = [\mathbf{F}^{-1}]^T [\mathbf{F}^{-1}] = \begin{bmatrix} 1 & 0 & 0 \\ -k & 1 & 0 \\ 0 & 0 & 1 \end{bmatrix} \begin{bmatrix} 1 & -k & 0 \\ 0 & 1 & 0 \\ 0 & 0 & 1 \end{bmatrix} = \begin{bmatrix} 1 & -k & 0 \\ -k & 1+k^2 & 0 \\ 0 & 0 & 1 \end{bmatrix}, \quad (iii)$$

$$\mathbf{e}^* = \frac{1}{2} (\mathbf{I} - \mathbf{B}^{-1}) = \frac{1}{2} \begin{bmatrix} 0 & k & 0 \\ k & -k^2 & 0 \\ 0 & 0 & 0 \end{bmatrix}. \quad (iv)$$

(b) Since $e_{11}^* = 0$, an element which is in the \mathbf{e}_1 direction in the deformed state (such as $B'C'$ in Figure 3.26-1) has the same length in the undeformed state (BC in the same figure).

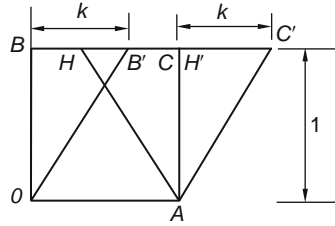

FIGURE 3.26-1

Also, since $e_{22}^* = -k^2/2$, an element which is in the \mathbf{e}_2 direction in the deformed state (such as AH') had a length AH , which can be calculated from an equation similar to Eq. (3.26.10). That is, from $(AH')^2 - (AH)^2 = 2(AH')^2 e_{22}^*$, we obtain

$$AH = (AH')\sqrt{1 + k^2}. \quad (\text{v})$$

This result checks with the geometry of Figure 3.26-1, where $AH' = OB = 1$ and $HH' = k$.

3.27 CHANGE OF AREA DUE TO DEFORMATION

Consider two material elements $d\mathbf{X}^{(1)} = dS_1\mathbf{e}_1$ and $d\mathbf{X}^{(2)} = dS_2\mathbf{e}_2$ emanating from \mathbf{X} . The rectangular area formed by $d\mathbf{X}^{(1)}$ and $d\mathbf{X}^{(2)}$ at the reference time t_0 is given by

$$d\mathbf{A}_0 = d\mathbf{X}^{(1)} \times d\mathbf{X}^{(2)} = dS_1 dS_2 \mathbf{e}_3 = dA_0 \mathbf{e}_3, \quad (3.27.1)$$

where dA_0 is the magnitude of the undeformed area and \mathbf{e}_3 is normal to the area. At time t , $d\mathbf{X}^{(1)}$ deforms into $d\mathbf{x}^{(1)} = \mathbf{F}d\mathbf{X}^{(1)}$ and $d\mathbf{X}^{(2)}$ deforms into $d\mathbf{x}^{(2)} = \mathbf{F}d\mathbf{X}^{(2)}$, and the deformed area is given by

$$d\mathbf{A} = \mathbf{F}d\mathbf{X}^{(1)} \times \mathbf{F}d\mathbf{X}^{(2)} = dS_1 dS_2 \mathbf{F}\mathbf{e}_1 \times \mathbf{F}\mathbf{e}_2 = dA_0 \mathbf{F}\mathbf{e}_1 \times \mathbf{F}\mathbf{e}_2. \quad (3.27.2)$$

Thus, the orientation of the deformed area is normal to $\mathbf{F}\mathbf{e}_1$ and $\mathbf{F}\mathbf{e}_2$. Let this normal direction be denoted by the unit vector \mathbf{n} , i.e.,

$$d\mathbf{A} = dA\mathbf{n}, \quad (3.27.3)$$

then we have

$$\mathbf{n} = \left(\frac{dA_0}{dA} \right) (\mathbf{F}\mathbf{e}_1 \times \mathbf{F}\mathbf{e}_2). \quad (3.27.4)$$

Now, $\mathbf{F}\mathbf{e}_1 \cdot (\mathbf{F}\mathbf{e}_1 \times \mathbf{F}\mathbf{e}_2) = \mathbf{F}\mathbf{e}_2 \cdot (\mathbf{F}\mathbf{e}_1 \times \mathbf{F}\mathbf{e}_2) = 0$; therefore,

$$\mathbf{F}\mathbf{e}_1 \cdot \mathbf{n} = \mathbf{F}\mathbf{e}_2 \cdot \mathbf{n} = 0, \quad (3.27.5)$$

thus,

$$\mathbf{e}_1 \cdot \mathbf{F}^T \mathbf{n} = \mathbf{e}_2 \cdot \mathbf{F}^T \mathbf{n} = 0. \quad (3.27.6)$$

That is, $\mathbf{F}^T \mathbf{n}$ is normal to \mathbf{e}_1 and \mathbf{e}_2 . Recalling that $\mathbf{a} \cdot \mathbf{b} \times \mathbf{c} = \text{determinant whose rows are components of the vectors } \mathbf{a}, \mathbf{b} \text{ and } \mathbf{c}$, we have, from Eq. (3.27.4),

$$\mathbf{F}\mathbf{e}_3 \cdot \mathbf{n} = \left(\frac{dA_0}{dA} \right) \mathbf{F}\mathbf{e}_3 \cdot (\mathbf{F}\mathbf{e}_1 \times \mathbf{F}\mathbf{e}_2) = \left(\frac{dA_0}{dA} \right) \det \mathbf{F}, \quad (3.27.7)$$

or

$$\mathbf{e}_3 \cdot \mathbf{F}^T \mathbf{n} = \frac{dA_0}{dA} \det \mathbf{F}. \quad (3.27.8)$$

From Eq. (3.27.6) and Eq. (3.27.8), we have

$$\mathbf{F}^T \mathbf{n} = \left[\frac{dA_0}{dA} (\det \mathbf{F}) \right] \mathbf{e}_3, \quad (3.27.9)$$

so that

$$d\mathbf{A}\mathbf{n} = dA_0 (\det \mathbf{F}) (\mathbf{F}^{-1})^T \mathbf{e}_3. \quad (3.27.10)$$

Thus, the area in the deformed state is related to the area in the undeformed state by the relation

$$dA = dA_0 (\det \mathbf{F}) \left| (\mathbf{F}^{-1})^T \mathbf{e}_3 \right|. \quad (3.27.11)$$

In deriving Eq. (3.27.11), we have chosen the initial area to be the rectangular area whose sides are parallel to the Cartesian base vectors \mathbf{e}_1 and \mathbf{e}_2 so that the undeformed area is normal to \mathbf{e}_3 . In general, if the undeformed area is normal to \mathbf{n}_0 , then Eq. (3.27.10) and Eq. (3.27.11) become

$$d\mathbf{A}\mathbf{n} = dA_0 J (\mathbf{F}^{-1})^T \mathbf{n}_0 \quad \text{and} \quad dA = dA_0 J \left| (\mathbf{F}^{-1})^T \mathbf{n}_0 \right|, \quad (3.27.12)$$

where, to emphasize that in deformation $\det \mathbf{F}$ is always positive,[‡] we write

$$J = |\det \mathbf{F}|. \quad (3.27.13)$$

3.28 CHANGE OF VOLUME DUE TO DEFORMATION

Consider three material elements $d\mathbf{X}^{(1)} = dS_1 \mathbf{e}_1$, $d\mathbf{X}^{(2)} = dS_2 \mathbf{e}_2$, and $d\mathbf{X}^{(3)} = dS_3 \mathbf{e}_3$ emanating from \mathbf{X} . The volume formed by $d\mathbf{X}^{(1)}$, $d\mathbf{X}^{(2)}$, and $d\mathbf{X}^{(3)}$ at the reference time t_0 is given by

$$dV_0 = dS_1 dS_2 dS_3. \quad (3.28.1)$$

At time t , $d\mathbf{X}^{(1)}$ deforms into $d\mathbf{x}^{(1)} = \mathbf{F}d\mathbf{X}^{(1)}$, $d\mathbf{X}^{(2)}$ deforms into $d\mathbf{x}^{(2)} = \mathbf{F}d\mathbf{X}^{(2)}$, and $d\mathbf{X}^{(3)}$ deforms into $d\mathbf{x}^{(3)} = \mathbf{F}d\mathbf{X}^{(3)}$, and the volume is

$$dV = |\mathbf{F}d\mathbf{X}^{(1)} \cdot \mathbf{F}d\mathbf{X}^{(2)} \times \mathbf{F}d\mathbf{X}^{(3)}| = dS_1 dS_2 dS_3 |\mathbf{F}\mathbf{e}_1 \cdot \mathbf{F}\mathbf{e}_2 \times \mathbf{F}\mathbf{e}_3|. \quad (3.28.2)$$

[‡]Reflection is not allowed in deformation, and we shall not consider those reference configurations that the body could not continuously get from without passing through a configuration for which $\det \mathbf{F} = 0$.

That is,

$$dV = dV_0 |\det \mathbf{F}| = J dV_0. \quad (3.28.3)$$

Now, $\mathbf{C} = \mathbf{F}^T \mathbf{F}$ and $\mathbf{B} = \mathbf{F} \mathbf{F}^T$; therefore,

$$\det \mathbf{C} = \det \mathbf{B} = (\det \mathbf{F})^2, \quad (3.28.4)$$

so that we have

$$dV = \sqrt{\det \mathbf{C}} dV_0 = \sqrt{\det \mathbf{B}} dV_0. \quad (3.28.5)$$

We note that for incompressible material $dV = dV_0$ and

$$\det \mathbf{F} = \det \mathbf{C} = \det \mathbf{B} = 1. \quad (3.28.6)$$

We also note that the conservation of mass equation $\rho dV = \rho_0 dV_0$ can also be written as

$$\rho = \frac{\rho_0}{\det \mathbf{F}} \quad \text{or} \quad \rho = \frac{\rho_0}{\sqrt{\det \mathbf{C}}} \quad \text{or} \quad \rho = \frac{\rho_0}{\sqrt{\det \mathbf{B}}}. \quad (3.28.7)$$

Example 3.28.1

The deformation of a body is given by

$$x_1 = \lambda_1 X_1, \quad x_2 = -\lambda_3 X_3, \quad x_3 = \lambda_2 X_2. \quad (i)$$

- (a) Find the deformed volume of the unit cube shown in Figure 3.28-1.
- (b) Find the deformed area $OABC$.
- (c) Find the rotation tensor and the axial vector of the antisymmetric part of the rotation tensor.

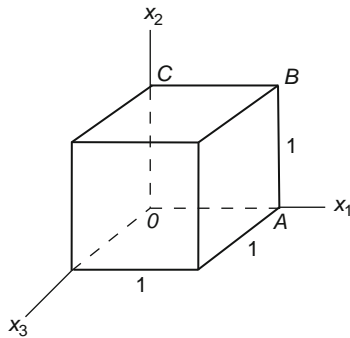

FIGURE 3.28-1

Solution

- (a) From (i),

$$[\mathbf{F}] = \begin{bmatrix} \lambda_1 & 0 & 0 \\ 0 & 0 & -\lambda_3 \\ 0 & \lambda_2 & 0 \end{bmatrix}, \det \mathbf{F} = \lambda_1 \lambda_2 \lambda_3.$$

Thus, from $dV = (\det \mathbf{F}) dV_0$, we have, since $\det \mathbf{F}$ is independent of position and $\Delta V_0 = 1$,

$$\Delta V = (\lambda_1 \lambda_2 \lambda_3) \Delta V_0 = \lambda_1 \lambda_2 \lambda_3.$$

(b) Using Eq. (3.27.12), with $\Delta A_0 = 1$, $\mathbf{n}_0 = -\mathbf{e}_3$, and

$$[\mathbf{F}^{-1}] = \begin{bmatrix} 1/\lambda_1 & 0 & 0 \\ 0 & 0 & 1/\lambda_2 \\ 0 & -1/\lambda_3 & 0 \end{bmatrix},$$

we have

$$\Delta \mathbf{A} \mathbf{n} = \Delta A_0 (\det \mathbf{F}) (\mathbf{F}^{-1})^\top \mathbf{n}_0 = (1)(\lambda_1 \lambda_2 \lambda_3) \begin{bmatrix} 1/\lambda_1 & 0 & 0 \\ 0 & 0 & -1/\lambda_3 \\ 0 & 1/\lambda_2 & 0 \end{bmatrix} \begin{bmatrix} 0 \\ 0 \\ -1 \end{bmatrix} = \begin{bmatrix} 0 \\ \lambda_1 \lambda_2 \\ 0 \end{bmatrix},$$

i.e.,

$$\Delta \mathbf{A} \mathbf{n} = \lambda_1 \lambda_2 \mathbf{e}_2.$$

Thus, the area $OABC$, which was of unit area, having a normal in the direction of $-\mathbf{e}_3$, becomes an area whose normal is in the direction of \mathbf{e}_2 and with a magnitude of $\lambda_1 \lambda_2$.

$$\begin{aligned} \text{(c) } [\mathbf{U}]^2 = [\mathbf{F}]^\top [\mathbf{F}] &= \begin{bmatrix} \lambda_1 & 0 & 0 \\ 0 & 0 & \lambda_2 \\ 0 & -\lambda_3 & 0 \end{bmatrix} \begin{bmatrix} \lambda_1 & 0 & 0 \\ 0 & 0 & -\lambda_3 \\ 0 & \lambda_2 & 0 \end{bmatrix} = \begin{bmatrix} \lambda_1^2 & 0 & 0 \\ 0 & \lambda_2^2 & 0 \\ 0 & 0 & \lambda_3^2 \end{bmatrix}, [\mathbf{U}] = \begin{bmatrix} \lambda_1 & 0 & 0 \\ 0 & \lambda_2 & 0 \\ 0 & 0 & \lambda_3 \end{bmatrix}, \\ [\mathbf{R}] = [\mathbf{F}][\mathbf{U}]^{-1} &= \begin{bmatrix} \lambda_1 & 0 & 0 \\ 0 & 0 & -\lambda_3 \\ 0 & \lambda_2 & 0 \end{bmatrix} \begin{bmatrix} 1/\lambda_1 & 0 & 0 \\ 0 & 1/\lambda_2 & 0 \\ 0 & 0 & 1/\lambda_3 \end{bmatrix} = \begin{bmatrix} 1 & 0 & 0 \\ 0 & 0 & -1 \\ 0 & 1 & 0 \end{bmatrix}. \end{aligned}$$

The dual vector of the antisymmetric part of this tensor \mathbf{R} is \mathbf{e}_1 . Thus, it represents a rotation about \mathbf{e}_1 axis. The angle of rotation is given by $\sin \theta = 1$, i.e., 90° (see Chapter 2).

3.29 COMPONENTS OF DEFORMATION TENSORS IN OTHER COORDINATES

The components of the deformation gradient \mathbf{F} , the left and right Cauchy-Green deformation tensors \mathbf{B} and \mathbf{C} and their inverses \mathbf{B}^{-1} and \mathbf{C}^{-1} , have been derived for the case where the same rectangular Cartesian coordinates have been used for both the reference and the current configurations. In this section, we consider the case where the base vectors at the reference configuration are different from those at the current configuration. Such situations arise not only in the case where different coordinate systems are used for the two configuration (for example, a rectangular coordinate system for the reference and a cylindrical coordinate for the current configuration) but also in cases where the same curvilinear coordinates are used for the two configurations. The following are examples.

(A) Cylindrical Coordinates System for Both the Reference and the Current Configuration

(A.1) Two-point components of \mathbf{F} . Let

$$r = r(r_0, \theta_0, z_0, t), \quad \theta = \theta(r_0, \theta_0, z_0, t), \quad z = z(r_0, \theta_0, z_0, t) \quad (3.29.1)$$

be the pathline equations. We first show that, with $\{\mathbf{e}_r, \mathbf{e}_\theta, \mathbf{e}_z\}$ and $\{\mathbf{e}_r^o, \mathbf{e}_\theta^o, \mathbf{e}_z^o\}$ denoting the basis in the current and the reference configuration, respectively,

$$\mathbf{F}\mathbf{e}_r^o = \frac{\partial r}{\partial r_o} \mathbf{e}_r + \frac{r\partial\theta}{\partial r_o} \mathbf{e}_\theta + \frac{\partial z}{\partial r_o} \mathbf{e}_z, \quad (3.29.2)$$

$$\mathbf{F}\mathbf{e}_\theta^o = \frac{\partial r}{r_o\partial\theta_o} \mathbf{e}_r + \frac{r\partial\theta}{r_o\partial\theta_o} \mathbf{e}_\theta + \frac{\partial z}{r_o\partial\theta_o} \mathbf{e}_z, \quad (3.29.3)$$

$$\mathbf{F}\mathbf{e}_z^o = \frac{\partial r}{\partial z_o} \mathbf{e}_r + \frac{r\partial\theta}{\partial z_o} \mathbf{e}_\theta + \frac{\partial z}{\partial z_o} \mathbf{e}_z. \quad (3.29.4)$$

To do that, we substitute

$$d\mathbf{x} = dr\mathbf{e}_r + r d\theta\mathbf{e}_\theta + dz\mathbf{e}_z \quad \text{and} \quad d\mathbf{X} = dr_o\mathbf{e}_r^o + r_o d\theta_o\mathbf{e}_\theta^o + dz_o\mathbf{e}_z^o, \quad (3.29.5)$$

into the equation $d\mathbf{x} = \mathbf{F}d\mathbf{X}$ to obtain

$$dr = dr_o\mathbf{e}_r \cdot \mathbf{F}\mathbf{e}_r^o + r_o d\theta_o\mathbf{e}_r \cdot \mathbf{F}\mathbf{e}_\theta^o + dz_o\mathbf{e}_r \cdot \mathbf{F}\mathbf{e}_z^o, \quad (3.29.6)$$

$$r d\theta = dr_o\mathbf{e}_\theta \cdot \mathbf{F}\mathbf{e}_r^o + r_o d\theta_o\mathbf{e}_\theta \cdot \mathbf{F}\mathbf{e}_\theta^o + dz_o\mathbf{e}_\theta \cdot \mathbf{F}\mathbf{e}_z^o, \quad (3.29.7)$$

$$dz = dr_o\mathbf{e}_z \cdot \mathbf{F}\mathbf{e}_r^o + r_o d\theta_o\mathbf{e}_z \cdot \mathbf{F}\mathbf{e}_\theta^o + dz_o\mathbf{e}_z \cdot \mathbf{F}\mathbf{e}_z^o. \quad (3.29.8)$$

Since $dr = \frac{\partial r}{\partial r_o} dr_o + \frac{\partial r}{\partial\theta_o} d\theta_o + \frac{\partial r}{\partial z_o} dz_o$, etc., therefore, we have

$$\mathbf{e}_r \cdot \mathbf{F}\mathbf{e}_r^o = \frac{\partial r}{\partial r_o}, \quad \mathbf{e}_r \cdot \mathbf{F}\mathbf{e}_\theta^o = \frac{\partial r}{r_o\partial\theta_o}, \quad \mathbf{e}_r \cdot \mathbf{F}\mathbf{e}_z^o = \frac{\partial r}{\partial z_o}, \quad (3.29.9)$$

$$\mathbf{e}_\theta \cdot \mathbf{F}\mathbf{e}_r^o = \frac{r\partial\theta}{\partial r_o}, \quad \mathbf{e}_\theta \cdot \mathbf{F}\mathbf{e}_\theta^o = \frac{r\partial\theta}{r_o\partial\theta_o}, \quad \mathbf{e}_\theta \cdot \mathbf{F}\mathbf{e}_z^o = \frac{r\partial\theta}{\partial z_o}, \quad (3.29.10)$$

$$\mathbf{e}_z \cdot \mathbf{F}\mathbf{e}_r^o = \frac{\partial z}{\partial r_o}, \quad \mathbf{e}_z \cdot \mathbf{F}\mathbf{e}_\theta^o = \frac{\partial z}{r_o\partial\theta_o}, \quad \mathbf{e}_z \cdot \mathbf{F}\mathbf{e}_z^o = \frac{\partial z}{\partial z_o}. \quad (3.29.11)$$

These equations are equivalent to Eqs. (3.29.2), (3.29.3), and (3.29.4). The matrix

$$[\mathbf{F}] = \begin{bmatrix} \frac{\partial r}{\partial r_o} & \frac{\partial r}{r_o\partial\theta_o} & \frac{\partial r}{\partial z_o} \\ \frac{r\partial\theta}{\partial r_o} & \frac{r\partial\theta}{r_o\partial\theta_o} & \frac{r\partial\theta}{\partial z_o} \\ \frac{\partial z}{\partial r_o} & \frac{\partial z}{r_o\partial\theta_o} & \frac{\partial z}{\partial z_o} \end{bmatrix} \{\mathbf{e}_i\} \{\mathbf{e}_j^o\}, \quad (3.29.12)$$

is based on two sets of bases, one at the reference configuration $\{\mathbf{e}_r^o, \mathbf{e}_\theta^o, \mathbf{e}_z^o\}$ and the other, the current configuration $\{\mathbf{e}_r, \mathbf{e}_\theta, \mathbf{e}_z\}$. The components in this matrix are called the *two-point components of the tensor \mathbf{F}* with respect to $\{\mathbf{e}_r, \mathbf{e}_\theta, \mathbf{e}_z\}$ and $\{\mathbf{e}_r^o, \mathbf{e}_\theta^o, \mathbf{e}_z^o\}$.

From Eq. (3.29.9), using the definition of transpose, we have

$$\mathbf{e}_r^o \cdot \mathbf{F}^T \mathbf{e}_r = \frac{\partial r}{\partial r_o}, \quad \mathbf{e}_\theta^o \cdot \mathbf{F}^T \mathbf{e}_r = \frac{\partial r}{r_o\partial\theta_o}, \quad \mathbf{e}_z^o \cdot \mathbf{F}^T \mathbf{e}_r = \frac{\partial r}{\partial z_o}, \quad (3.29.13)$$

thus

$$\mathbf{F}^T \mathbf{e}_r = \frac{\partial r}{\partial r_o} \mathbf{e}_r^o + \frac{\partial r}{r_o \partial \theta_o} \mathbf{e}_\theta^o + \frac{\partial r}{\partial z_o} \mathbf{e}_z^o. \quad (3.29.14)$$

Similarly, from Eqs. (3.29.10) and (3.29.11) we can obtain

$$\mathbf{F}^T \mathbf{e}_\theta = \frac{r \partial \theta}{\partial r_o} \mathbf{e}_r^o + \frac{r \partial \theta}{r_o \partial \theta_o} \mathbf{e}_\theta^o + \frac{r \partial \theta}{\partial z_o} \mathbf{e}_z^o, \quad (3.29.15)$$

$$\mathbf{F}^T \mathbf{e}_z = \frac{\partial z}{\partial r_o} \mathbf{e}_r^o + \frac{\partial z}{r_o \partial \theta_o} \mathbf{e}_\theta^o + \frac{\partial z}{\partial z_o} \mathbf{e}_z^o. \quad (3.29.16)$$

(A.2) Components of the left Cauchy-Green tensor \mathbf{B} , with respect to the basis at the current position \mathbf{x} , can be obtained as follows:

$$B_{rr} = \mathbf{e}_r \cdot \mathbf{B} \mathbf{e}_r = \mathbf{e}_r \cdot \mathbf{F} \mathbf{F}^T \mathbf{e}_r = \mathbf{e}_r \cdot \mathbf{F} \left(\frac{\partial r}{\partial r_o} \mathbf{e}_r^o + \frac{\partial r}{r_o \partial \theta_o} \mathbf{e}_\theta^o + \frac{\partial r}{\partial z_o} \mathbf{e}_z^o \right), \quad (3.29.17)$$

$$B_{r\theta} = \mathbf{e}_r \cdot \mathbf{B} \mathbf{e}_\theta = \mathbf{e}_r \cdot \mathbf{F} \mathbf{F}^T \mathbf{e}_\theta = \mathbf{e}_r \cdot \mathbf{F} \left(\frac{r \partial \theta}{\partial r_o} \mathbf{e}_r^o + \frac{r \partial \theta}{r_o \partial \theta_o} \mathbf{e}_\theta^o + \frac{r \partial \theta}{\partial z_o} \mathbf{e}_z^o \right). \quad (3.29.18)$$

Using Eq. (3.29.9), we have

$$B_{rr} = \left(\frac{\partial r}{\partial r_o} \right)^2 + \left(\frac{\partial r}{r_o \partial \theta_o} \right)^2 + \left(\frac{\partial r}{\partial z_o} \right)^2, \quad (3.29.19)$$

$$B_{r\theta} = \left(\frac{r \partial \theta}{\partial r_o} \right) \left(\frac{\partial r}{\partial r_o} \right) + \left(\frac{r \partial \theta}{r_o \partial \theta_o} \right) \left(\frac{\partial r}{r_o \partial \theta_o} \right) + \left(\frac{r \partial \theta}{\partial z_o} \right) \left(\frac{\partial r}{\partial z_o} \right). \quad (3.29.20)$$

The other components can be similarly derived:

$$B_{\theta\theta} = \left(\frac{r \partial \theta}{\partial r_o} \right)^2 + \left(\frac{r \partial \theta}{r_o \partial \theta_o} \right)^2 + \left(\frac{r \partial \theta}{\partial z_o} \right)^2, \quad (3.29.21)$$

$$B_{zz} = \left(\frac{\partial z}{\partial r_o} \right)^2 + \left(\frac{\partial z}{r_o \partial \theta_o} \right)^2 + \left(\frac{\partial z}{\partial z_o} \right)^2, \quad (3.29.22)$$

$$B_{rz} = \left(\frac{\partial r}{\partial r_o} \right) \left(\frac{\partial z}{\partial r_o} \right) + \left(\frac{\partial r}{r_o \partial \theta_o} \right) \left(\frac{\partial z}{r_o \partial \theta_o} \right) + \left(\frac{\partial r}{\partial z_o} \right) \left(\frac{\partial z}{\partial z_o} \right), \quad (3.29.23)$$

$$B_{z\theta} = \left(\frac{\partial z}{\partial r_o} \right) \left(\frac{r \partial \theta}{\partial r_o} \right) + \left(\frac{\partial z}{r_o \partial \theta_o} \right) \left(\frac{r \partial \theta}{r_o \partial \theta_o} \right) + \left(\frac{\partial z}{\partial z_o} \right) \left(\frac{r \partial \theta}{\partial z_o} \right). \quad (3.29.24)$$

We note that the same result can be obtained from $[\mathbf{F}][\mathbf{F}]^T$, where $[\mathbf{F}]$ is given in Eq. (3.29.12).

(A.3) Components of \mathbf{B}^{-1} with respect to the basis at \mathbf{x} .

The components of \mathbf{B}^{-1} can be obtained from inverting $[\mathbf{B}]$ above. But it is often more convenient to express it in terms of the inverse of the pathline Eq. (3.29.1):

$$r_o = r_o(r, \theta, z, t), \quad \theta_o = \theta_o(r, \theta, z, t), \quad z_o = z_o(r, \theta, z, t). \quad (3.29.25)$$

From $d\mathbf{X} = \mathbf{F}^{-1} d\mathbf{x}$ and Eq. (3.29.5), we have

$$dr_o \mathbf{e}_r^o + r_o d\theta_o \mathbf{e}_\theta^o + dz_o \mathbf{e}_z^o = \mathbf{F}^{-1} (dr \mathbf{e}_r + r d\theta \mathbf{e}_\theta + dz \mathbf{e}_z), \quad (3.29.26)$$

thus

$$dr_o = dr(\mathbf{e}_r^\circ \cdot \mathbf{F}^{-1} \mathbf{e}_r) + r d\theta(\mathbf{e}_\theta^\circ \cdot \mathbf{F}^{-1} \mathbf{e}_\theta) + dz(\mathbf{e}_z^\circ \cdot \mathbf{F}^{-1} \mathbf{e}_z). \quad (3.29.27)$$

Since $dr_o = \frac{\partial r_o}{\partial r} dr + \frac{\partial r_o}{\partial \theta} d\theta + \frac{\partial r_o}{\partial z} dz$, etc.,

$$\mathbf{e}_r^\circ \cdot \mathbf{F}^{-1} \mathbf{e}_r = \frac{\partial r_o}{\partial r}, \quad \mathbf{e}_\theta^\circ \cdot \mathbf{F}^{-1} \mathbf{e}_\theta = \frac{\partial r_o}{r \partial \theta}, \quad \mathbf{e}_z^\circ \cdot \mathbf{F}^{-1} \mathbf{e}_z = \frac{\partial r_o}{\partial z}. \quad (3.29.28)$$

Similarly, one can obtain

$$\mathbf{e}_r^\circ \cdot \mathbf{F}^{-1} \mathbf{e}_r = \frac{r_o \partial \theta_o}{\partial r}, \quad \mathbf{e}_\theta^\circ \cdot \mathbf{F}^{-1} \mathbf{e}_\theta = \frac{r_o \partial \theta_o}{r \partial \theta}, \quad \mathbf{e}_z^\circ \cdot \mathbf{F}^{-1} \mathbf{e}_z = \frac{r_o \partial \theta_o}{\partial z}, \quad \text{etc.} \quad (3.29.29)$$

Equivalently,

$$\mathbf{F}^{-1} \mathbf{e}_r = \frac{\partial r_o}{\partial r} \mathbf{e}_r^\circ + \frac{r_o \partial \theta_o}{\partial r} \mathbf{e}_\theta^\circ + \frac{\partial z_o}{\partial r} \mathbf{e}_z^\circ, \quad (3.29.30)$$

$$\mathbf{F}^{-1} \mathbf{e}_\theta = \frac{\partial r_o}{r \partial \theta} \mathbf{e}_r^\circ + \frac{r_o \partial \theta_o}{r \partial \theta} \mathbf{e}_\theta^\circ + \frac{\partial z_o}{r \partial \theta} \mathbf{e}_z^\circ, \quad (3.29.31)$$

$$\mathbf{F}^{-1} \mathbf{e}_z = \frac{\partial r_o}{\partial z} \mathbf{e}_r^\circ + \frac{r_o \partial \theta_o}{\partial z} \mathbf{e}_\theta^\circ + \frac{\partial z_o}{\partial z} \mathbf{e}_z^\circ. \quad (3.29.32)$$

Also, we have, by the definition of transpose,

$$\mathbf{e}_r \cdot (\mathbf{F}^{-1})^T \mathbf{e}_r^\circ = \mathbf{e}_r^\circ \cdot \mathbf{F}^{-1} \mathbf{e}_r = \frac{\partial r_o}{\partial r}, \quad \mathbf{e}_\theta \cdot (\mathbf{F}^{-1})^T \mathbf{e}_r^\circ = \mathbf{e}_r^\circ \cdot \mathbf{F}^{-1} \mathbf{e}_\theta = \frac{\partial r_o}{r \partial \theta}, \quad \text{etc.},$$

therefore

$$(\mathbf{F}^{-1})^T \mathbf{e}_r^\circ = \frac{\partial r_o}{\partial r} \mathbf{e}_r + \frac{\partial r_o}{r \partial \theta} \mathbf{e}_\theta + \frac{\partial z_o}{\partial z} \mathbf{e}_z, \quad (3.29.33)$$

$$(\mathbf{F}^{-1})^T \mathbf{e}_\theta^\circ = \frac{r_o \partial \theta_o}{\partial r} \mathbf{e}_r + \frac{r_o \partial \theta_o}{r \partial \theta} \mathbf{e}_\theta + \frac{r_o \partial \theta_o}{\partial z} \mathbf{e}_z, \quad (3.29.34)$$

$$(\mathbf{F}^{-1})^T \mathbf{e}_z^\circ = \frac{\partial z_o}{\partial r} \mathbf{e}_r + \frac{\partial z_o}{r \partial \theta} \mathbf{e}_\theta + \frac{\partial z_o}{\partial z} \mathbf{e}_z. \quad (3.29.35)$$

Now, with respect to the basis at \mathbf{x} , we have

$$B_{rr}^{-1} = \mathbf{e}_r \cdot \mathbf{B}^{-1} \mathbf{e}_r = \mathbf{e}_r \cdot (\mathbf{F}\mathbf{F}^T)^{-1} \mathbf{e}_r = \mathbf{e}_r \cdot (\mathbf{F}^{-1})^T (\mathbf{F}^{-1} \mathbf{e}_r) \quad (3.29.36)$$

$$\begin{aligned} &= \left(\frac{\partial r_o}{\partial r} \mathbf{e}_r \cdot (\mathbf{F}^{-1})^T \mathbf{e}_r^\circ + \frac{r_o \partial \theta_o}{\partial r} \mathbf{e}_r \cdot (\mathbf{F}^{-1})^T \mathbf{e}_\theta^\circ + \frac{\partial z_o}{\partial r} \mathbf{e}_r \cdot (\mathbf{F}^{-1})^T \mathbf{e}_z^\circ \right) \\ &= \left(\frac{\partial r_o}{\partial r} \right)^2 + \left(\frac{r_o \partial \theta_o}{\partial r} \right)^2 + \left(\frac{\partial z_o}{\partial r} \right)^2. \end{aligned} \quad (3.29.37)$$

The other components can be similarly derived (see Prob.3.77):

$$B_{\theta\theta}^{-1} = \left(\frac{\partial r_o}{r \partial \theta} \right)^2 + \left(\frac{r_o \partial \theta_o}{r \partial \theta} \right)^2 + \left(\frac{\partial z_o}{r \partial \theta} \right)^2, \quad (3.29.38)$$

$$B_{zz}^{-1} = \left(\frac{\partial r_o}{\partial z} \right)^2 + \left(\frac{r_o \partial \theta_o}{\partial z} \right)^2 + \left(\frac{\partial z_o}{\partial z} \right)^2, \quad (3.29.39)$$

$$B_{r\theta}^{-1} = \left(\frac{\partial r_o}{\partial r}\right) \left(\frac{\partial r_o}{r\partial\theta}\right) + \left(\frac{r_o\partial\theta_o}{\partial r}\right) \left(\frac{r_o\partial\theta_o}{r\partial\theta}\right) + \left(\frac{\partial z_o}{\partial r}\right) \left(\frac{\partial z_o}{r\partial\theta}\right), \quad (3.29.40)$$

$$B_{rz}^{-1} = \left(\frac{\partial r_o}{\partial r}\right) \left(\frac{\partial r_o}{\partial z}\right) + \left(\frac{r_o\partial\theta_o}{\partial r}\right) \left(\frac{r_o\partial\theta_o}{\partial z}\right) + \left(\frac{\partial z_o}{\partial r}\right) \left(\frac{\partial z_o}{\partial z}\right), \quad (3.29.41)$$

$$B_{z\theta}^{-1} = \left(\frac{\partial r_o}{\partial z}\right) \left(\frac{\partial r_o}{r\partial\theta}\right) + \left(\frac{r_o\partial\theta_o}{\partial z}\right) \left(\frac{r_o\partial\theta_o}{r\partial\theta}\right) + \left(\frac{\partial z_o}{\partial z}\right) \left(\frac{\partial z_o}{r\partial\theta}\right). \quad (3.29.42)$$

(A.4) Components of the right Cauchy-Green tensor \mathbf{C} , with respect to the basis at the reference position \mathbf{X} . Using Eq. (3.29.1), that is,

$$r = r(r_o, \theta_o, z_o, t), \quad \theta = \theta(r_o, \theta_o, z_o, t), \quad z = z(r_o, \theta_o, z_o, t),$$

we can obtain [see Eqs. (3.29.2) to (3.29.4) and Eqs. (3.29.14) to (3.29.16)]

$$C_{r_o r_o} = \mathbf{e}_r^o \cdot \mathbf{C} \mathbf{e}_r^o = \mathbf{e}_r^o \cdot \mathbf{F}^T \mathbf{F} \mathbf{e}_r^o = \frac{\partial r}{\partial r_o} \mathbf{e}_r^o \cdot \mathbf{F}^T \mathbf{e}_r + \frac{r\partial\theta}{\partial r_o} \mathbf{e}_r^o \cdot \mathbf{F}^T \mathbf{e}_\theta + \frac{\partial z}{\partial r_o} \mathbf{e}_r^o \cdot \mathbf{F}^T \mathbf{e}_z, \quad (3.29.43)$$

$$C_{r_o \theta_o} = \mathbf{e}_r^o \cdot \mathbf{C} \mathbf{e}_\theta^o = \mathbf{e}_r^o \cdot \mathbf{F}^T \mathbf{F} \mathbf{e}_\theta^o = \frac{\partial r}{r_o \partial \theta_o} \mathbf{e}_r^o \cdot \mathbf{F}^T \mathbf{e}_r + \frac{r\partial\theta}{r_o \partial \theta_o} \mathbf{e}_r^o \cdot \mathbf{F}^T \mathbf{e}_\theta + \frac{\partial z}{r_o \partial \theta_o} \mathbf{e}_r^o \cdot \mathbf{F}^T \mathbf{e}_z, \quad (3.29.44)$$

i.e.,

$$C_{r_o r_o} = \left(\frac{\partial r}{\partial r_o}\right)^2 + \left(\frac{r\partial\theta}{\partial r_o}\right)^2 + \left(\frac{\partial z}{\partial r_o}\right)^2, \quad (3.29.45)$$

$$C_{r_o \theta_o} = \left(\frac{\partial r}{r_o \partial \theta_o}\right) \left(\frac{\partial r}{\partial r_o}\right) + \left(\frac{r\partial\theta}{r_o \partial \theta_o}\right) \left(\frac{r\partial\theta}{\partial r_o}\right) + \left(\frac{\partial z}{r_o \partial \theta_o}\right) \left(\frac{\partial z}{\partial r_o}\right). \quad (3.29.46)$$

Other components can be similarly derived: They are [see Probs. 3.78 and 3.79]

$$C_{\theta_o \theta_o} = \left(\frac{\partial r}{r_o \partial \theta_o}\right)^2 + \left(\frac{r\partial\theta}{r_o \partial \theta_o}\right)^2 + \left(\frac{\partial z}{r_o \partial \theta_o}\right)^2, \quad (3.29.47)$$

$$C_{z_o z_o} = \left(\frac{\partial r}{\partial z_o}\right)^2 + \left(\frac{r\partial\theta}{\partial z_o}\right)^2 + \left(\frac{\partial z}{\partial z_o}\right)^2, \quad (3.29.48)$$

$$C_{r_o \theta_o} = \left(\frac{\partial r}{r_o \partial \theta_o}\right) \left(\frac{\partial r}{\partial r_o}\right) + \left(\frac{r\partial\theta}{r_o \partial \theta_o}\right) \left(\frac{r\partial\theta}{\partial r_o}\right) + \left(\frac{\partial z}{r_o \partial \theta_o}\right) \left(\frac{\partial z}{\partial r_o}\right), \quad (3.29.49)$$

$$C_{r_o z_o} = \left(\frac{\partial r}{\partial r_o}\right) \left(\frac{\partial r}{\partial z_o}\right) + \left(\frac{r\partial\theta}{\partial r_o}\right) \left(\frac{r\partial\theta}{\partial z_o}\right) + \left(\frac{\partial z}{\partial r_o}\right) \left(\frac{\partial z}{\partial z_o}\right), \quad (3.29.50)$$

$$C_{z_o \theta_o} = \left(\frac{\partial r}{\partial z_o}\right) \left(\frac{\partial r}{r_o \partial \theta_o}\right) + \left(\frac{r\partial\theta}{\partial z_o}\right) \left(\frac{r\partial\theta}{r_o \partial \theta_o}\right) + \left(\frac{\partial z}{\partial z_o}\right) \left(\frac{\partial z}{r_o \partial \theta_o}\right). \quad (3.29.51)$$

(A.5) Components of \mathbf{C}^{-1}

The components of \mathbf{C}^{-1} can be obtained from inverting $[\mathbf{C}]$ above. But it is often more convenient to express it in terms of the inverse of the pathline Eq. (3.29.1):

$$r_o = r_o(r, \theta, z, t), \quad \theta_o = \theta_o(r, \theta, z, t), \quad z_o = z_o(r, \theta, z, t).$$

We have (see Prob. 3.80)

$$\begin{aligned} C_{r_o r_o}^{-1} &= \mathbf{e}_r^o \cdot (\mathbf{F}^T \mathbf{F})^{-1} \mathbf{e}_r^o = \mathbf{e}_r^o \cdot \mathbf{F}^{-1} (\mathbf{F}^{-1})^T \mathbf{e}_r^o = \frac{\partial r_o}{\partial r} \mathbf{e}_r^o \cdot \mathbf{F}^{-1} \mathbf{e}_r + \frac{\partial r_o}{r \partial \theta} \mathbf{e}_r^o \cdot \mathbf{F}^{-1} \mathbf{e}_\theta + \frac{\partial r_o}{\partial z} \mathbf{e}_r^o \cdot \mathbf{F}^{-1} \mathbf{e}_z \\ &= \frac{\partial r_o}{\partial r} \frac{\partial r_o}{\partial r} + \frac{\partial r_o}{r \partial \theta} \frac{\partial r_o}{r \partial \theta} + \frac{\partial r_o}{\partial z} \frac{\partial r_o}{\partial z}, \end{aligned} \quad (3.29.52)$$

$$\begin{aligned} C_{r_o \theta_o}^{-1} &= \mathbf{e}_r^o \cdot (\mathbf{F}^T \mathbf{F})^{-1} \mathbf{e}_\theta^o = \mathbf{e}_r^o \cdot \mathbf{F}^{-1} (\mathbf{F}^{-1})^T \mathbf{e}_\theta^o = \frac{r_o \partial \theta_o}{\partial r} \mathbf{e}_r^o \cdot \mathbf{F}^{-1} \mathbf{e}_r + \frac{r_o \partial \theta_o}{r \partial \theta} \mathbf{e}_r^o \cdot \mathbf{F}^{-1} \mathbf{e}_\theta + \frac{r_o \partial \theta_o}{\partial z} \mathbf{e}_r^o \cdot \mathbf{F}^{-1} \mathbf{e}_z \\ &= \left(\frac{r_o \partial \theta_o}{\partial r} \right) \left(\frac{\partial r_o}{\partial r} \right) + \left(\frac{r_o \partial \theta_o}{r \partial \theta} \right) \left(\frac{\partial r_o}{r \partial \theta} \right) + \left(\frac{r_o \partial \theta_o}{\partial z} \right) \left(\frac{\partial r_o}{\partial z} \right). \end{aligned} \quad (3.29.53)$$

The other components can be written down easily following the previous procedure.

(B) Cylindrical Coordinates (r, θ, z) for the Current Configuration and Rectangular Cartesian Coordinates (X, Y, Z) for the Reference Configuration

Let

$$r = r(X, Y, Z, t), \quad \theta = \theta(X, Y, Z, t), \quad z = z(X, Y, Z, t) \quad (3.29.54)$$

be the pathline equations. Then, using the same procedure as described for the case where one single cylindrical coordinate is used for both references, it can be derived that (see Prob. 3.81)

$$\mathbf{F} \mathbf{e}_X = \frac{\partial r}{\partial X} \mathbf{e}_r + \frac{r \partial \theta}{\partial X} \mathbf{e}_\theta + \frac{\partial z}{\partial X} \mathbf{e}_z, \quad (3.29.55)$$

$$\mathbf{F} \mathbf{e}_Y = \frac{\partial r}{\partial Y} \mathbf{e}_r + \frac{r \partial \theta}{\partial Y} \mathbf{e}_\theta + \frac{\partial z}{\partial Y} \mathbf{e}_z, \quad (3.29.56)$$

$$\mathbf{F} \mathbf{e}_Z = \frac{\partial r}{\partial Z} \mathbf{e}_r + \frac{r \partial \theta}{\partial Z} \mathbf{e}_\theta + \frac{\partial z}{\partial Z} \mathbf{e}_z. \quad (3.29.57)$$

That is, the two point components of \mathbf{F} with respect to $\{\mathbf{e}_r, \mathbf{e}_\theta, \mathbf{e}_z\}$ and $\{\mathbf{e}_X, \mathbf{e}_Y, \mathbf{e}_Z\}$ are

$$[\mathbf{F}] = \begin{bmatrix} \frac{\partial r}{\partial X} & \frac{\partial r}{\partial Y} & \frac{\partial r}{\partial Z} \\ \frac{r \partial \theta}{\partial X} & \frac{r \partial \theta}{\partial Y} & \frac{r \partial \theta}{\partial Z} \\ \frac{\partial z}{\partial X} & \frac{\partial z}{\partial Y} & \frac{\partial z}{\partial Z} \end{bmatrix}_{\{\mathbf{e}_r, \mathbf{e}_\theta, \mathbf{e}_z\}; \{\mathbf{e}_X, \mathbf{e}_Y, \mathbf{e}_Z\}}. \quad (3.29.58)$$

(B.1) Components of the left Cauchy-Green deformation tensor \mathbf{B} with respect to the basis at the current configuration \mathbf{x} , i.e., $\{\mathbf{e}_r, \mathbf{e}_\theta, \mathbf{e}_z\}$, are

$$B_{rr} = \mathbf{e}_r \cdot \mathbf{F} \mathbf{F}^T \mathbf{e}_r = \left(\frac{\partial r}{\partial X} \right)^2 + \left(\frac{\partial r}{\partial Y} \right)^2 + \left(\frac{\partial r}{\partial Z} \right)^2, \quad (3.29.59)$$

$$B_{\theta\theta} = \mathbf{e}_\theta \cdot \mathbf{F}\mathbf{F}^T \mathbf{e}_\theta = \left(\frac{r\partial\theta}{\partial X} \right)^2 + \left(\frac{r\partial\theta}{\partial Y} \right)^2 + \left(\frac{r\partial\theta}{\partial Z} \right)^2, \quad (3.29.60)$$

$$B_{zz} = \mathbf{e}_z \cdot \mathbf{F}\mathbf{F}^T \mathbf{e}_z = \left(\frac{\partial z}{\partial X} \right)^2 + \left(\frac{\partial z}{\partial Y} \right)^2 + \left(\frac{\partial z}{\partial Z} \right)^2, \quad (3.29.61)$$

$$B_{r\theta} = \mathbf{e}_r \cdot \mathbf{F}\mathbf{F}^T \mathbf{e}_\theta = \left(\frac{\partial r}{\partial X} \right) \left(\frac{r\partial\theta}{\partial X} \right) + \left(\frac{\partial r}{\partial Y} \right) \left(\frac{r\partial\theta}{\partial Y} \right) + \left(\frac{\partial r}{\partial Z} \right) \left(\frac{r\partial\theta}{\partial Z} \right), \quad (3.29.62)$$

$$B_{rz} = \mathbf{e}_r \cdot \mathbf{F}\mathbf{F}^T \mathbf{e}_z = \left(\frac{\partial r}{\partial X} \right) \left(\frac{\partial z}{\partial X} \right) + \left(\frac{\partial r}{\partial Y} \right) \left(\frac{\partial z}{\partial Y} \right) + \left(\frac{\partial r}{\partial Z} \right) \left(\frac{\partial z}{\partial Z} \right), \quad (3.29.63)$$

$$B_{\theta z} = \mathbf{e}_\theta \cdot \mathbf{F}\mathbf{F}^T \mathbf{e}_z = \left(\frac{r\partial\theta}{\partial X} \right) \left(\frac{\partial z}{\partial X} \right) + \left(\frac{r\partial\theta}{\partial Y} \right) \left(\frac{\partial z}{\partial Y} \right) + \left(\frac{r\partial\theta}{\partial Z} \right) \left(\frac{\partial z}{\partial Z} \right). \quad (3.29.64)$$

(B.2) Components of \mathbf{B}^{-1} with respect to the basis at the current configuration \mathbf{x} .

Again, it is often more convenient to express the components in terms of the pathline equations in the form of

$$X = X(r, \theta, z, t), \quad Y = Y(r, \theta, z, t), \quad Z = Z(r, \theta, z, t). \quad (3.29.65)$$

Using the equation $d\mathbf{X} = \mathbf{F}^{-1}d\mathbf{x}$, one can obtain

$$B_{rr}^{-1} = \mathbf{e}_r \cdot (\mathbf{F}^{-1})^T \mathbf{F}^{-1} \mathbf{e}_r = \left(\frac{\partial X}{\partial r} \right)^2 + \left(\frac{\partial Y}{\partial r} \right)^2 + \left(\frac{\partial Z}{\partial r} \right)^2, \quad (3.29.66)$$

$$B_{r\theta}^{-1} = \mathbf{e}_r \cdot (\mathbf{F}^{-1})^T \mathbf{F}^{-1} \mathbf{e}_\theta = \left(\frac{\partial X}{\partial r} \right) \left(\frac{\partial X}{\partial r\partial\theta} \right) + \left(\frac{\partial Y}{\partial r} \right) \left(\frac{\partial Y}{\partial r\partial\theta} \right) + \left(\frac{\partial Z}{\partial r} \right) \left(\frac{\partial Z}{\partial r\partial\theta} \right). \quad (3.29.67)$$

The other components can be written down following the patterns of the preceding equations.

(B.3) Components of the right-Cauchy Green Tensor \mathbf{C} with respect to the basis at the reference configuration, i.e., $\{\mathbf{e}_X, \mathbf{e}_Y, \mathbf{e}_Z\}$:

$$C_{XX} = \left(\frac{\partial r}{\partial X} \right)^2 + \left(\frac{r\partial\theta}{\partial X} \right)^2 + \left(\frac{\partial z}{\partial X} \right)^2, \quad (3.29.68)$$

$$C_{XY} = \left(\frac{\partial r}{\partial X} \right) \left(\frac{\partial r}{\partial Y} \right) + \left(\frac{r\partial\theta}{\partial X} \right) \left(\frac{r\partial\theta}{\partial Y} \right) + \left(\frac{\partial z}{\partial X} \right) \left(\frac{\partial z}{\partial Y} \right). \quad (3.29.69)$$

The other components can be easily written down following the preceding patterns.

(B.4) Components of \mathbf{C}^{-1} with respect to the basis $\{\mathbf{e}_X, \mathbf{e}_Y, \mathbf{e}_Z\}$:

$$C_{XX}^{-1} = \left(\frac{\partial X}{\partial r} \right)^2 + \left(\frac{\partial X}{\partial r\partial\theta} \right)^2 + \left(\frac{\partial X}{\partial z} \right)^2, \quad (3.29.70)$$

$$C_{XY}^{-1} = \left(\frac{\partial X}{\partial r} \right) \left(\frac{\partial Y}{\partial r} \right) + \left(\frac{\partial X}{\partial r\partial\theta} \right) \left(\frac{\partial Y}{\partial r\partial\theta} \right) + \left(\frac{\partial X}{\partial z} \right) \left(\frac{\partial Y}{\partial z} \right). \quad (3.29.71)$$

The other components can be easily written down following the preceding patterns.

(C) Spherical Coordinate System for Both the Reference and the Current Configurations

Let

$$r = r(r_o, \theta_o, \phi_o, t), \quad \theta = \theta(r_o, \theta_o, \phi_o, t), \quad z = z(r_o, \theta_o, \phi_o, t) \quad (3.29.72)$$

be the pathline equations. It can be derived that the two-point components for \mathbf{F} with respect to the basis at current configuration $\{\mathbf{e}_r, \mathbf{e}_\theta, \mathbf{e}_z\}$ and that at the reference configuration $\{\mathbf{e}_r^o, \mathbf{e}_\theta^o, \mathbf{e}_z^o\}$ are

$$[\mathbf{F}] = \begin{bmatrix} \frac{\partial r}{\partial r_o} & \frac{\partial r}{r_o \partial \theta_o} & \frac{\partial r}{r_o \sin \theta_o \partial \phi_o} \\ \frac{r \partial \theta}{\partial r_o} & \frac{r \partial \theta}{r_o \partial \theta_o} & \frac{r \partial \theta}{r_o \sin \theta_o \partial \phi_o} \\ \frac{r \sin \theta \partial \phi}{\partial r_o} & \frac{r \sin \theta \partial \phi}{r_o \partial \theta_o} & \frac{r \sin \theta \partial \phi}{r_o \sin \theta_o \partial \phi_o} \end{bmatrix} \cdot \quad (3.29.73)$$

$\{\mathbf{e}_r^o, \mathbf{e}_\theta^o, \mathbf{e}_z^o\}, \{\mathbf{e}_r, \mathbf{e}_\theta, \mathbf{e}_z\}$

(C.1) Components of the left Cauchy-Green tensor \mathbf{B} are

$$B_{rr} = \left(\frac{\partial r}{\partial r_o}\right)^2 + \left(\frac{\partial r}{r_o \partial \theta_o}\right)^2 + \left(\frac{\partial r}{r_o \sin \theta_o \partial \phi_o}\right)^2, \quad (3.29.74)$$

$$B_{r\theta} = \left(\frac{\partial r}{\partial r_o}\right) \left(\frac{r \partial \theta}{\partial r_o}\right) + \left(\frac{\partial r}{r_o \partial \theta_o}\right) \left(\frac{r \partial \theta}{r_o \partial \theta_o}\right) + \left(\frac{\partial r}{r_o \sin \theta_o \partial \phi_o}\right) \left(\frac{r \partial \theta}{r_o \sin \theta_o \partial \phi_o}\right). \quad (3.29.75)$$

The other components can be written down following the preceding pattern.

(C.2) Components of \mathbf{B}^{-1} are

$$B_{rr}^{-1} = \left(\frac{\partial r_o}{\partial r}\right)^2 + \left(\frac{r_o \partial \theta_o}{\partial r}\right)^2 + \left(\frac{r_o \sin \theta_o \partial \phi_o}{\partial r}\right)^2, \quad (3.29.76)$$

$$B_{r\theta}^{-1} = \left(\frac{\partial r_o}{\partial r}\right) \left(\frac{\partial r_o}{r \partial \theta}\right) + \left(\frac{r_o \partial \theta_o}{\partial r}\right) \left(\frac{r_o \partial \theta_o}{r \partial \theta}\right) + \left(\frac{r_o \sin \theta_o \partial \phi_o}{\partial r}\right) \left(\frac{r_o \sin \theta_o \partial \phi_o}{r \partial \theta}\right). \quad (3.29.77)$$

The other components can be written down following the preceding pattern.

(C.3) Components of the right Cauchy-Green tensor \mathbf{C} with respect to the basis at the reference configuration, i.e., $\{\mathbf{e}_r^o, \mathbf{e}_\theta^o, \mathbf{e}_z^o\}$:

$$C_{r_o r_o} = \left(\frac{\partial r}{\partial r_o}\right)^2 + \left(\frac{r \partial \theta}{\partial r_o}\right)^2 + \left(\frac{r \sin \theta \partial \phi}{\partial r_o}\right)^2, \quad (3.29.78)$$

$$C_{r_o \theta_o} = \left(\frac{\partial r}{\partial r_o}\right) \left(\frac{\partial r}{r_o \partial \theta_o}\right) + \left(\frac{r \partial \theta}{\partial r_o}\right) \left(\frac{r \partial \theta}{r_o \partial \theta_o}\right) + \left(\frac{r \sin \theta \partial \phi}{\partial r_o}\right) \left(\frac{r \sin \theta \partial \phi}{r_o \partial \theta_o}\right). \quad (3.29.79)$$

The other components can be written down following the preceding pattern.

(C.4) Components of \mathbf{C}^{-1} with respect to $\{\mathbf{e}_r^o, \mathbf{e}_\theta^o, \mathbf{e}_z^o\}$:

$$C_{r_o r_o}^{-1} = \left(\frac{\partial r_o}{\partial r}\right)^2 + \left(\frac{\partial r_o}{r \partial \theta}\right)^2 + \left(\frac{\partial r_o}{r \sin \theta \partial \phi}\right)^2, \quad (3.29.80)$$

$$C_{r_o \theta_o}^{-1} = \left(\frac{\partial r_o}{\partial r}\right) \left(\frac{r_o \partial \theta_o}{\partial r}\right) + \left(\frac{\partial r_o}{r \partial \theta}\right) \left(\frac{r_o \partial \theta_o}{r \partial \theta}\right) + \left(\frac{\partial r_o}{r \sin \theta \partial \phi}\right) \left(\frac{r_o \partial \theta_o}{r \sin \theta \partial \phi}\right). \quad (3.29.81)$$

The other components can be written down following the preceding pattern.

3.30 CURRENT CONFIGURATION AS THE REFERENCE CONFIGURATION

Let \mathbf{x} be the position vector of a particle at current time t , and let \mathbf{x}' be the position vector of the same particle at time τ . Then the equation

$$\mathbf{x}' = \mathbf{x}'_t(\mathbf{x}, \tau) \quad \text{with} \quad \mathbf{x} = \mathbf{x}'_t(\mathbf{x}, t), \quad (3.30.1)$$

defines the motion of a continuum using the current time t as the reference time. The subscript t in the function $\mathbf{x}'_t(\mathbf{x}, \tau)$ indicates that the current time t is the reference time and as such, $\mathbf{x}'_t(\mathbf{x}, \tau)$ is also a function of t .

For a given velocity field $\mathbf{v} = \mathbf{v}(\mathbf{x}, t)$, the velocity at the position \mathbf{x}' at time τ is $v = (\mathbf{x}', \tau)$. On the other hand, for a particular particle (i.e., for fixed \mathbf{x} and t), the velocity at time τ is given by $\left(\frac{\partial \mathbf{x}'_t}{\partial \tau}\right)_{\mathbf{x}, t - \text{fixed}}$. Thus,

$$\mathbf{v}(\mathbf{x}', \tau) = \frac{\partial \mathbf{x}'_t}{\partial \tau}. \quad (3.30.2)$$

Example 3.30.1

Given the velocity field

$$v_1 = kx_2, \quad v_2 = v_3 = 0. \quad (i)$$

Find the pathline equations using the current configuration as the reference configuration.

Solution

In component form, Eq. (3.30.2) gives

$$\frac{\partial x'_1}{\partial \tau} = kx'_2, \quad \frac{\partial x'_2}{\partial \tau} = \frac{\partial x'_3}{\partial \tau} = 0. \quad (ii)$$

The initial conditions are

$$\text{at } \tau = t, \quad x'_1 = x_1, \quad x'_2 = x_2 \quad \text{and} \quad x'_3 = x_3. \quad (iii)$$

The second and the third equation of (ii) state that both x'_2 and x'_3 are independent of τ so that

$$x'_2 = x_2 \quad \text{and} \quad x'_3 = x_3. \quad (iv)$$

From the first equation of (ii), we have, since $x'_2 = x_2$,

$$x'_1 = kx_2\tau + C. \quad (v)$$

Applying the initial condition that at $\tau = t, x'_1 = x_1$, we have

$$x'_1 = x_1 + kx_2(\tau - t). \quad (vi)$$

When the current configuration is used as the reference, it is customary also to denote tensors based on such a reference with a subscript t , e.g.,

$\mathbf{F}_t \equiv \nabla \mathbf{x}'_t$ (relative deformation gradient)

$\mathbf{C}_t \equiv \mathbf{F}_t^T \mathbf{F}_t$ (relative right Cauchy-Green Tensor)

$\mathbf{B}_t \equiv \mathbf{F}_t \mathbf{F}_t^T$ (relative left Cauchy-Green Tensor)

and so on. All the formulas derived earlier, based on a fixed reference configuration, can be easily rewritten for the present case where the current configuration is used as the reference. Care should be taken in the different notations used in the previous section (Section 3.29) and in the present section. For example, let (r', θ', z') denote the cylindrical coordinates for the position \mathbf{x}' at time τ for a material point that is at (r, θ, z) at time t , i.e.,

$$r' = r'(r, \theta, z, \tau), \quad \theta' = \theta'(r, \theta, z, \tau), \quad z' = z'(r, \theta, z, \tau). \quad (3.30.3)$$

These equations correspond to Eq. (3.29.1) in Section 3.29, where

$$r = r(r_0, \theta_0, z_0, t), \quad \theta = \theta(r_0, \theta_0, z_0, t), \quad z = z(r_0, \theta_0, z_0, t)$$

so that with respect to the current basis $\{\mathbf{e}_r, \mathbf{e}_\theta, \mathbf{e}_z\}$, we have, from Eqs. (3.29.45) and (3.29.46) of Section 3.29,

$$(C_t)_{rr} = \left(\frac{\partial r'}{\partial r}\right)^2 + \left(\frac{r' \partial \theta'}{\partial r}\right)^2 + \left(\frac{\partial z'}{\partial r}\right)^2, \quad (3.30.4)$$

$$(C_t)_{r\theta} = \left(\frac{\partial r'}{\partial r}\right) \left(\frac{\partial r'}{r \partial \theta}\right) + \left(\frac{r' \partial \theta'}{\partial r}\right) \left(\frac{r' \partial \theta'}{r \partial \theta}\right) + \left(\frac{\partial z'}{\partial r}\right) \left(\frac{\partial z'}{r \partial \theta}\right). \quad (3.30.5)$$

and so on. We will have more to say about relative deformation tensors in Chapter 8, where we discuss the constitutive equations for non-Newtonian fluids.

APPENDIX 3.1: NECESSARY AND SUFFICIENT CONDITIONS FOR STRAIN COMPATIBILITY

For any given set of six functions for the six infinitesimal strain components $E_{ij}(X_1, X_2, X_3)$, we have derived the six necessary conditions, Eqs. (3.16.7) to (3.16.12), which the given strain functions must satisfy for the existence of three displacement functions u_1, u_2, u_3 whose strains are the given set functions. Here in this appendix, we will show that those conditions are both necessary and sufficient. The establishment of the necessary and sufficient conditions for strain components will be based on the well-known necessary and sufficient conditions for a differential $Pdx + Qdy + Rdz$ to be exact, where P, Q and R , are functions of (x, y, z) . These conditions are given in any text in advance calculus. They are

$$\frac{\partial P}{\partial y} = \frac{\partial Q}{\partial x}, \quad \frac{\partial P}{\partial z} = \frac{\partial R}{\partial x}, \quad \frac{\partial Q}{\partial z} = \frac{\partial R}{\partial y}. \quad (A3.1.1)$$

When these conditions are satisfied, the differential $Pdx + Qdy + Rdz$ is said to be an exact differential and a function $W(x, y, z)$ exists such that

$$dW = Pdx + Qdy + Rdz. \quad (A3.1.2)$$

As a consequence, the line integral $\int_a^b Pdx + Qdy + Rdz$ depends only on the end points a and b ; in fact, it is equal to $W(x_b, y_b, z_b) - W(x_a, y_a, z_a)$. That is, the integral is independent of path. In indicial notation, we write

$$P_1(x_1, x_2, x_3)dx_1 + P_2(x_1, x_2, x_3)dx_2 + P_3(x_1, x_2, x_3)dx_3 = P_k(x_1, x_2, x_3)dx_k, \quad (A3.1.3)$$

and the necessary and sufficient conditions for $P_k(x_1, x_2, x_3)dx_k$ to be an exact differential can be written as:

$$\frac{\partial P_k}{\partial x_j} = \frac{\partial P_j}{\partial x_k}. \quad (A3.1.4)$$

The following gives the derivation of compatibility conditions.

Let $u_i(X_1, X_2, X_3)$ be displacement components at a generic point (X_1, X_2, X_3) . Then, at $P^o(X_1^o, X_2^o, X_3^o)$, the displacement components are $u_i^o = u_i^o(X_1^o, X_2^o, X_3^o)$, and at $P'(X_1', X_2', X_3')$, the displacement components are $u_i' = u_i'(X_1', X_2', X_3')$.

We can obtain the displacement components u_i' at P' from the components u_i^o at P^o by a line integral from any chosen path. Thus,

$$u_i' = u_i^o + \int_{P^o}^{P'} du_i \quad \text{where} \quad du_i = \frac{\partial u_i}{\partial X_m} dX_m. \quad (\text{A3.1.5})$$

In terms of the displacement function, the line integral is clearly independent of path so long as the functions $u_i(X_1, X_2, X_3)$ are single valued. Indeed,

$$u_i' = u_i^o + \int_{P^o}^{P'} du_i = u_i^o + (u_i' - u_i^o) = u_i'. \quad (\text{A3.1.6})$$

On the other hand, if we evaluate the line integral in terms of the strain components, then certain conditions must be satisfied by these components in order that the line integral is independent of path. Let us now express du_i in terms of the strain components and the rotation components: We have

$$du_i = \frac{\partial u_i}{\partial X_m} dX_m = \left[\frac{1}{2} \left(\frac{\partial u_i}{\partial X_m} + \frac{\partial u_m}{\partial X_i} \right) + \frac{1}{2} \left(\frac{\partial u_i}{\partial X_m} - \frac{\partial u_m}{\partial X_i} \right) \right] dX_m = (E_{im} + W_{im}) dX_m, \quad (\text{A3.1.7})$$

thus,

$$\int_{P^o}^{P'} du_i = \int_{P^o}^{P'} E_{im} dX_m + \int_{P^o}^{P'} W_{im} dX_m. \quad (\text{A3.1.8})$$

The last integral in Eq. (A3.1.8) can be evaluated as follows:

$$\begin{aligned} \int_{P^o}^{P'} W_{im} dX_m &= \int_{P^o}^{P'} W_{im} d(X_m - X_m') = W_{im}(X_m - X_m') \Big|_{X_m=X_m^o}^{X_m=X_m'} - \int_{P^o}^{P'} (X_m - X_m') dW_{im} \\ &= -W_{im}^o(X_m^o - X_m') - \int_{P^o}^{P'} (X_m - X_m') dW_{im}. \end{aligned} \quad (\text{A3.1.9})$$

Thus, using Eq. (A3.1.8) and Eq. (A3.1.9), Eq. (A3.1.5) becomes:

$$(u_i)_{P'} = (u_i)_{P^o} - W_{im}^o(X_m^o - X_m') + \int_{P^o}^{P'} \left[E_{ik} - (X_m - X_m') \frac{\partial W_{im}}{\partial X_k} \right] dX_k. \quad (\text{A3.1.10})$$

Now, using the definition of E_{im} and W_{im} in Eq. (A3.1.7), it can be simply obtained (see Prob. 3.56) that

$$\frac{\partial W_{im}}{\partial X_k} = \frac{\partial E_{ik}}{\partial X_m} - \frac{\partial E_{km}}{\partial X_i}, \quad (\text{A3.1.11})$$

so that

$$(u_i)_{P'} = (u_i)_{P^o} - W_{im}^o(X_m^o - X_m') + \int_{P^o}^{P'} R_{ik} dX_k, \quad (\text{A3.1.12})$$

where

$$R_{ik} = E_{ik} - (X_m - X_m') \left(\frac{\partial E_{ik}}{\partial X_m} - \frac{\partial E_{km}}{\partial X_i} \right). \quad (\text{A3.1.13})$$

We demand that u_i must be single-value functions of the coordinates. Therefore, the integral

$$\int_{p^o}^{p'} R_{ik} dX_k = \int_{p^o}^{p'} [R_{i1}(X_1, X_2, X_3) dX_1 + R_{i2}(X_1, X_2, X_3) dX_2 + R_{i3}(X_1, X_2, X_3) dX_3],$$

must be independent of path. That is, $R_{ik} dX_k$ must be an exact differential of a single-value function for each i . The necessary and sufficient conditions for $R_{ik} dX_k$ to be an exact differential are [see Eq. (A3.1.4)]

$$\frac{\partial R_{ik}}{\partial X_j} = \frac{\partial R_{ij}}{\partial X_k}, \quad (\text{A3.1.14})$$

i.e.,

$$\begin{aligned} & \frac{\partial E_{ik}}{\partial X_j} - \frac{\partial X_m}{\partial X_j} \left(\frac{\partial E_{ik}}{\partial X_m} - \frac{\partial E_{km}}{\partial X_i} \right) - (X_m - X'_m) \frac{\partial}{\partial X_j} \left(\frac{\partial E_{ik}}{\partial X_m} - \frac{\partial E_{km}}{\partial X_i} \right) \\ &= \frac{\partial E_{ij}}{\partial X_k} - \frac{\partial X_m}{\partial X_k} \left(\frac{\partial E_{ij}}{\partial X_m} - \frac{\partial E_{jm}}{\partial X_i} \right) - (X_m - X'_m) \frac{\partial}{\partial X_k} \left(\frac{\partial E_{ij}}{\partial X_m} - \frac{\partial E_{jm}}{\partial X_i} \right). \end{aligned} \quad (\text{A3.1.15})$$

Noting that $\partial X_m / \partial X_j = \delta_{mj}$ and $\partial X_m / \partial X_k = \delta_{mk}$, so that

$$\frac{\partial X_m}{\partial X_j} \left(\frac{\partial E_{ik}}{\partial X_m} - \frac{\partial E_{km}}{\partial X_i} \right) = \frac{\partial E_{ik}}{\partial X_j} - \frac{\partial E_{kj}}{\partial X_i} \quad \text{and} \quad \frac{\partial X_m}{\partial X_k} \left(\frac{\partial E_{ij}}{\partial X_m} - \frac{\partial E_{jm}}{\partial X_i} \right) = \frac{\partial E_{ij}}{\partial X_k} - \frac{\partial E_{jk}}{\partial X_i}, \quad (\text{A3.1.16})$$

and we have

$$(X_m - X'_m) \left\{ \frac{\partial}{\partial X_j} \left(\frac{\partial E_{ik}}{\partial X_m} - \frac{\partial E_{km}}{\partial X_i} \right) - \frac{\partial}{\partial X_k} \left(\frac{\partial E_{ij}}{\partial X_m} - \frac{\partial E_{jm}}{\partial X_i} \right) \right\} = 0, \quad (\text{A3.1.17})$$

therefore

$$\frac{\partial}{\partial X_k} \left(\frac{\partial E_{ij}}{\partial X_m} - \frac{\partial E_{jm}}{\partial X_i} \right) - \frac{\partial}{\partial X_j} \left(\frac{\partial E_{ik}}{\partial X_m} - \frac{\partial E_{km}}{\partial X_i} \right) = 0, \quad (\text{A3.1.18})$$

that is,

$$\frac{\partial^2 E_{ij}}{\partial X_k \partial X_m} + \frac{\partial^2 E_{km}}{\partial X_j \partial X_i} - \frac{\partial^2 E_{ik}}{\partial X_j \partial X_m} - \frac{\partial^2 E_{jm}}{\partial X_k \partial X_i} = 0. \quad (\text{A3.1.19})$$

There are four free indices in the preceding equation, so there are superficially 81 equations. However, many different sets of indices lead to the same equation; for example, all the following sets of indices:

$$\{i = j = 1, k = m = 2\}, \{k = m = 1, i = j = 2\}, \{i = k = 1, j = m = 2\}, \{j = m = 1, i = k = 2\}$$

lead to the same equation:

$$\frac{\partial^2 E_{11}}{\partial X_2^2} + \frac{\partial^2 E_{22}}{\partial X_1^2} = 2 \frac{\partial^2 E_{12}}{\partial X_1 \partial X_2}. \quad (\text{A3.1.20})$$

Indeed, of the 81 equations, only six are distinct, and they are given in Section 3.16 as necessary conditions. We have now shown that they are the necessary and sufficient conditions for the strains to be compatible.

APPENDIX 3.2: POSITIVE DEFINITE SYMMETRIC TENSORS

A real symmetric tensor \mathbf{T} is positive definite if $U = \mathbf{a} \cdot \mathbf{T}\mathbf{a} > 0$ for any nonzero real vector \mathbf{a} . In this appendix, we show that for a positive definite real symmetric tensor with matrix $[\mathbf{T}] = [T_{ij}]$

$$\begin{aligned} T_{11} > 0, T_{22} > 0, T_{33} > 0, \\ \begin{vmatrix} T_{11} & T_{12} \\ T_{21} & T_{22} \end{vmatrix} > 0, \begin{vmatrix} T_{22} & T_{23} \\ T_{32} & T_{33} \end{vmatrix} > 0, \begin{vmatrix} T_{11} & T_{13} \\ T_{31} & T_{33} \end{vmatrix} > 0, \end{aligned} \quad (\text{A3.2.1})$$

and $|\mathbf{T}| > 0$.

To prove that $T_{11} > 0$, we choose $[\mathbf{a}] = [a_1, 0, 0]$, then we get

$$U = \mathbf{a} \cdot \mathbf{T}\mathbf{a} = T_{11}a_1^2 > 0. \quad (\text{A3.2.2})$$

Thus, we have $T_{11} > 0$. Similarly, by choosing $[\mathbf{a}] = [0, a_2, 0]$ and $[\mathbf{a}] = [0, 0, a_3]$, we obtain that $T_{22} > 0$ and $T_{33} > 0$. That is, the diagonal elements of a real positive definite tensor are all positive. Next, we choose $[\mathbf{a}] = [a_1, a_2, 0]$, then

$$U = [a_1 \ a_2 \ 0] \begin{bmatrix} T_{11} & T_{12} & T_{13} \\ T_{21} & T_{22} & T_{23} \\ T_{31} & T_{32} & T_{33} \end{bmatrix} \begin{bmatrix} a_1 \\ a_2 \\ 0 \end{bmatrix} = [a_1 \ a_2] \begin{bmatrix} T_{11} & T_{12} \\ T_{21} & T_{22} \end{bmatrix} \begin{bmatrix} a_1 \\ a_2 \end{bmatrix} > 0. \quad (\text{A3.2.3})$$

Thus, the submatrix $\begin{bmatrix} T_{11} & T_{12} \\ T_{21} & T_{22} \end{bmatrix}$ is positive definite. Similarly, if we choose

$$[\mathbf{a}] = [0 \ a_2 \ a_3] \text{ or } [\mathbf{a}] = [a_1 \ 0 \ a_3],$$

we can show that

$$\begin{bmatrix} T_{22} & T_{23} \\ T_{32} & T_{33} \end{bmatrix} \text{ and } \begin{bmatrix} T_{11} & T_{13} \\ T_{31} & T_{33} \end{bmatrix}$$

are positive definite.

Now for a positive definite symmetric tensor, the determinant is equal to the product of the eigenvalues which are all positive as they are the diagonal elements of the matrix using eigenvectors as a basis. Thus, we have

$$\begin{vmatrix} T_{11} & T_{12} \\ T_{21} & T_{22} \end{vmatrix} > 0, \begin{vmatrix} T_{22} & T_{23} \\ T_{32} & T_{33} \end{vmatrix} > 0, \begin{vmatrix} T_{11} & T_{13} \\ T_{31} & T_{33} \end{vmatrix} > 0, \begin{vmatrix} T_{11} & T_{12} & T_{13} \\ T_{21} & T_{22} & T_{23} \\ T_{31} & T_{32} & T_{33} \end{vmatrix} > 0. \quad (\text{A3.2.4})$$

APPENDIX 3.3: THE POSITIVE DEFINITE ROOT OF $\mathbf{U}^2 = \mathbf{D}$

In this appendix, we show that if $[\mathbf{U}^2] = [\mathbf{D}]$, where $[\mathbf{U}]$ is a real positive definite matrix and $[\mathbf{D}]$ is a real positive definite diagonal matrix, then $[\mathbf{U}]$ must also be diagonal and there is only one positive definite root for the equation. We first discuss the two-dimensional case, which is very simple and provides a good introduction to the three dimensional case.

(A) 2D Case: The equation $[\mathbf{U}^2] = [\mathbf{D}]$ gives:

$$\begin{bmatrix} U_{11} & U_{12} \\ U_{21} & U_{22} \end{bmatrix} \begin{bmatrix} U_{11} & U_{12} \\ U_{21} & U_{22} \end{bmatrix} = \begin{bmatrix} a & 0 \\ 0 & b \end{bmatrix},$$

thus,

$$U_{11}U_{12} + U_{12}U_{22} = 0 \quad \text{and} \quad U_{21}U_{11} + U_{22}U_{21} = 0,$$

so that

$$U_{12}(U_{11} + U_{22}) = 0 \quad \text{and} \quad U_{21}(U_{11} + U_{22}) = 0. \quad (\text{A3.3.1})$$

Since \mathbf{U} is positive definite, $U_{11} > 0$ and $U_{22} > 0$; therefore,

$$U_{12} = U_{21} = 0. \quad (\text{A3.3.2})$$

Now, with a diagonal \mathbf{U} , the equation $[\mathbf{U}]^2 = \begin{bmatrix} U_{11}^2 & 0 \\ 0 & U_{22}^2 \end{bmatrix} = \begin{bmatrix} a & 0 \\ 0 & b \end{bmatrix}$, has four roots for $[\mathbf{U}]$. They are

$$\begin{bmatrix} \sqrt{a} & 0 \\ 0 & \sqrt{b} \end{bmatrix}, \begin{bmatrix} \sqrt{a} & 0 \\ 0 & -\sqrt{b} \end{bmatrix}, \begin{bmatrix} -\sqrt{a} & 0 \\ 0 & \sqrt{b} \end{bmatrix} \quad \text{and} \quad \begin{bmatrix} -\sqrt{a} & 0 \\ 0 & -\sqrt{b} \end{bmatrix}. \quad (\text{A3.3.3})$$

The only root that is positive definite is

$$\begin{bmatrix} \sqrt{a} & 0 \\ 0 & \sqrt{b} \end{bmatrix}. \quad (\text{A3.3.4})$$

(B) 3D Case: From $[\mathbf{U}^2] = [\mathbf{D}]$, we have

$$\begin{aligned} U_{11}U_{12} + U_{12}U_{22} + U_{13}U_{32} &= D_{12} = 0 \\ U_{11}U_{13} + U_{12}U_{23} + U_{13}U_{33} &= D_{13} = 0 \\ U_{21}U_{13} + U_{22}U_{23} + U_{23}U_{33} &= D_{23} = 0, \end{aligned} \quad (\text{A3.3.5})$$

From the first equation in Eq. (A3.3.5), we have $U_{12}(U_{11} + U_{22}) = -U_{13}U_{32}$. Thus,

$$U_{12} = -\frac{U_{13}U_{32}}{(U_{11} + U_{22})} \quad (\text{A3.3.6})$$

where $U_{11} + U_{22} > 0$ because $[\mathbf{U}]$ is positive definite. Substituting Eq. (A3.3.6) into the second equation in Eq. (A3.3.5), we have

$$U_{13}(U_{11} + U_{33}) - \frac{U_{13}U_{32}}{(U_{11} + U_{22})}U_{23} = 0. \quad (\text{A3.3.7})$$

Thus,

$$U_{13}[U_{11}(U_{11} + U_{33} + U_{22}) + U_{22}U_{33} - U_{32}U_{23}] = 0. \quad (\text{A3.3.8})$$

Since $[\mathbf{U}]$ is positive definite, $U_{11} > 0, U_{22} > 0, U_{33} > 0$ and $U_{22}U_{33} - U_{32}U_{23} > 0$, thus,

$$U_{13} = 0. \quad (\text{A3.3.9})$$

With $U_{13} = 0$, the first equation and the third equation in Eq. (A3.3.5) become $U_{12}(U_{11} + U_{22}) = 0$ and $U_{23}(U_{22} + U_{33}) = 0$ respectively. Thus, we have

$$U_{12} = 0 \quad \text{and} \quad U_{23} = 0. \quad (\text{A3.3.10})$$

Similarly, $D_{21} = D_{31} = D_{32} = 0$ lead to $U_{21} = 0, U_{32} = 0$ and $U_{31} = 0$. Thus $[\mathbf{U}] = [\text{diagonal}]$. The equation $[\mathbf{U}^2] = [\mathbf{D}]$ has the following eight roots:

$$\begin{aligned} & \begin{bmatrix} \sqrt{a} & 0 & 0 \\ 0 & \sqrt{b} & 0 \\ 0 & 0 & \sqrt{c} \end{bmatrix}, \begin{bmatrix} \sqrt{a} & 0 & 0 \\ 0 & -\sqrt{b} & 0 \\ 0 & 0 & \sqrt{c} \end{bmatrix}, \begin{bmatrix} \sqrt{a} & 0 & 0 \\ 0 & \sqrt{b} & 0 \\ 0 & 0 & -\sqrt{c} \end{bmatrix}, \begin{bmatrix} \sqrt{a} & 0 & 0 \\ 0 & -\sqrt{b} & 0 \\ 0 & 0 & -\sqrt{c} \end{bmatrix}, \\ & \begin{bmatrix} -\sqrt{a} & 0 & 0 \\ 0 & \sqrt{b} & 0 \\ 0 & 0 & \sqrt{c} \end{bmatrix}, \begin{bmatrix} -\sqrt{a} & 0 & 0 \\ 0 & \sqrt{b} & 0 \\ 0 & 0 & -\sqrt{c} \end{bmatrix}, \begin{bmatrix} -\sqrt{a} & 0 & 0 \\ 0 & -\sqrt{b} & 0 \\ 0 & 0 & \sqrt{c} \end{bmatrix}, \begin{bmatrix} -\sqrt{a} & 0 & 0 \\ 0 & -\sqrt{b} & 0 \\ 0 & 0 & -\sqrt{c} \end{bmatrix}. \end{aligned}$$

All roots are real but only the first one is positive definite, that is,

$$[U] = \begin{bmatrix} \sqrt{a} & 0 & 0 \\ 0 & \sqrt{b} & 0 \\ 0 & 0 & \sqrt{c} \end{bmatrix}. \quad (\text{A3.3.11})$$

We note also, that if $[\mathbf{U}_1]$ is a positive definite symmetric matrix, then with respect to a set of principal axes, $[\mathbf{U}_1]$ and $[\mathbf{U}_1]^2$ are positive definite diagonal matrices. An equation such as $[\mathbf{U}_2]^2 = [\mathbf{U}_1]^2$ where both $[\mathbf{U}_1]$ and $[\mathbf{U}_2]$ are positive definite symmetric matrices then leads to the result that $[\mathbf{U}_1] = [\mathbf{U}_2]$.

PROBLEMS FOR CHAPTER 3

- 3.1** Consider the motion: $x_1 = \frac{1+kt}{1+kt_0}X_1$, $x_2 = X_2$, $x_3 = X_3$.
- Show that the reference time is $t = t_0$.
 - Find the velocity field in spatial coordinates.
 - Show that the velocity field is identical to that of the following motion: $x_1 = (1+kt)X_1$, $x_2 = X_2$, $x_3 = X_3$.
- 3.2** Consider the motion: $x_1 = \alpha t + X_1$, $x_2 = X_2$, $x_3 = X_3$, where the material coordinates X_i designate the position of a particle at $t = 0$.
- Determine the velocity and acceleration of a particle in both a material and a spatial description.
 - If the temperature field in spatial description is given by $\theta = Ax_1$, what is its material description? Find the material derivative of θ using both descriptions of the temperature.
 - Do part (b) if the temperature field is $\theta = Bx_2$.
- 3.3** Consider the motion $x_1 = X_1$, $x_2 = \beta X_1^2 t^2 + X_2$, $x_3 = X_3$, where X_i are the material coordinates.
- At $t = 0$, the corners of a unit square are at $A(0, 0, 0)$, $B(0, 1, 0)$, $C(1, 1, 0)$ and $D(1, 0, 0)$. Determine the position of $ABCD$ at $t = 1$ and sketch the new shape of the square.
 - Find the velocity \mathbf{v} and the acceleration in a material description.
 - Find the spatial velocity field.
- 3.4** Consider the motion: $x_1 = \beta X_2^2 t^2 + X_1$, $x_2 = kX_2 t + X_2$, $x_3 = X_3$.
- At $t = 0$, the corners of a unit square are at $A(0, 0, 0)$, $B(0, 1, 0)$, $C(1, 1, 0)$ and $D(1, 0, 0)$. Sketch the deformed shape of the square at $t = 2$.
 - Obtain the spatial description of the velocity field.
 - Obtain the spatial description of the acceleration field.

- 3.5** Consider the motion $x_1 = k(s + X_1)t + X_1$, $x_2 = X_2$, $x_3 = X_3$.
- (a) For this motion, repeat part (a) of the previous problem.
 (b) Find the velocity and acceleration as a function of time of a particle that is initially at the origin.
 (c) Find the velocity and acceleration as a function of time of the particles that are passing through the origin.
- 3.6** The position at time t of a particle initially at (X_1, X_2, X_3) is given by $x_1 = X_1 - 2\beta X_2^2 t^2$, $x_2 = X_2 - kX_3 t$, $x_3 = X_3$, where $\beta = 1$ and $k = 1$.
- (a) Sketch the deformed shape, at time $t = 1$, of the material line OA , which was a straight line at $t = 0$ with the point O at $(0, 0, 0)$ and the point A at $(0, 1, 0)$.
 (b) Find the velocity at $t = 2$ of the particle that was at $(1, 3, 1)$ at $t = 0$.
 (c) Find the velocity of the particle that is at $(1, 3, 1)$ at $t = 2$.
- 3.7** The position at time t of a particle initially at (X_1, X_2, X_3) is given by: $x_1 = X_1 + k(X_1 + X_2)t$, $x_2 = X_2 + k(X_1 + X_2)t$, $x_3 = X_3$.
- (a) Find the velocity at $t = 2$ of the particle that was at $(1, 1, 0)$ at the reference time $t = 0$.
 (b) Find the velocity of the particle that is at $(1, 1, 0)$ at $t = 2$.
- 3.8** The position at time t of a particle initially at (X_1, X_2, X_3) is given by: $x_1 = X_1 + \beta X_2^2 t^2$, $x_2 = X_2 + kX_2 t$, $x_3 = X_3$ where $\beta = 1$ and $k = 1$.
- (a) For the particle that was initially at $(1, 1, 0)$, what are its positions in the following instant of time? $t = 0$, $t = 1$, $t = 2$.
 (b) Find the initial position for a particle that is at $(1, 3, 2)$ at $t = 2$.
 (c) Find the acceleration at $t = 2$ of the particle that was initially at $(1, 3, 2)$.
 (d) Find the acceleration of a particle which is at $(1, 3, 2)$ at $t = 2$.
- 3.9** (a) Show that the velocity field $v_i = kx_i/(1 + kt)$ corresponds to the motion $x_i = X_i(1 + kt)$.
 (b) Find the acceleration of this motion in material description.
- 3.10** Given the two-dimensional velocity field: $v_x = -2y$, $v_y = 2x$. (a) Obtain the acceleration field and (b) obtain the pathline equations.
- 3.11** Given the two-dimensional velocity field: $v_x = kx$, $v_y = -ky$. (a) Obtain the acceleration field and (b) obtain the pathline equations.
- 3.12** Given the two-dimensional velocity field: $v_x = k(x^2 - y^2)$, $v_y = -2kxy$. Obtain the acceleration field.
- 3.13** In a spatial description, the equation $D\mathbf{v}/Dt = \partial\mathbf{v}/\partial t + (\nabla\mathbf{v})\mathbf{v}$ for evaluating the acceleration is nonlinear. That is, if we consider two velocity fields \mathbf{v}^A and \mathbf{v}^B , then $\mathbf{a}^A + \mathbf{a}^B \neq \mathbf{a}^{A+B}$, where \mathbf{a}^A and \mathbf{a}^B denote respectively the acceleration fields corresponding to the velocity fields \mathbf{v}^A and \mathbf{v}^B each existing alone, \mathbf{a}^{A+B} denotes the acceleration field corresponding to the combined velocity field $\mathbf{v}^A + \mathbf{v}^B$. Verify this inequality for the velocity fields:

$$\mathbf{v}^A = -2x_2\mathbf{e}_1 + 2x_1\mathbf{e}_2, \quad \mathbf{v}^B = 2x_2\mathbf{e}_1 - 2x_1\mathbf{e}_2.$$

- 3.14** Consider the motion: $x_1 = X_1$, $x_2 = X_2 + (\sin \pi t)(\sin \pi X_1)$, $x_3 = X_3$.
- (a) At $t = 0$, a material filament coincides with the straight line that extends from $(0, 0, 0)$ to $(1, 0, 0)$. Sketch the deformed shape of this filament at $t = 1/2$, $t = 1$ and $t = 3/2$.
 (b) Find the velocity and acceleration in a material and a spatial description.
- 3.15** Consider the following velocity and temperature fields:

$$\mathbf{v} = \frac{\alpha(x_1\mathbf{e}_1 + x_2\mathbf{e}_2)}{x_1^2 + x_2^2}, \quad \Theta = k(x_1^2 + x_2^2).$$

- (a) Write the preceding fields in polar coordinates and discuss the general nature of the given velocity field and temperature field (e.g., what do the flow and the isotherms look like?).
- (b) At the point $A(1, 1, 0)$, determine the acceleration and the material derivative of the temperature field.
- 3.16** Do the previous problem for the following velocity and temperature fields: $\mathbf{v} = \frac{\alpha(-x_2\mathbf{e}_1 + x_1\mathbf{e}_2)}{x_1^2 + x_2^2}$, $\Theta = k(x_1^2 + x_2^2)$.

3.17 Consider the motion given by:

$$\mathbf{x} = \mathbf{X} + X_1\mathbf{e}_1.$$

Let $d\mathbf{X}^{(1)} = (dS_1/\sqrt{2})(\mathbf{e}_1 + \mathbf{e}_2)$ and $d\mathbf{X}^{(2)} = (dS_2/\sqrt{2})(-\mathbf{e}_1 + \mathbf{e}_2)$ be differential material elements in the undeformed configuration.

- (a) Find the deformed elements $d\mathbf{x}^{(1)}$ and $d\mathbf{x}^{(2)}$.
- (b) Evaluate the stretches of these elements ds_1/dS_1 and ds_2/dS_2 and the change in the angle between them.
- (c) Do part (b) for $k = 1$ and $k = 10^{-2}$.
- (d) Compare the results of part (c) to that predicted by the small strain tensor \mathbf{E} .
- 3.18** Consider the motion $\mathbf{x} = \mathbf{X} + \mathbf{A}\mathbf{X}$, where \mathbf{A} is a small constant tensor (i.e., whose components are small in magnitude and independent of X_i). Show that the infinitesimal strain tensor is given by $\mathbf{E} = (\mathbf{A} + \mathbf{A}^T)/2$.

- 3.19** At time t , the position of a particle, initially at (X_1, X_2, X_3) , is defined by: $x_1 = X_1 + kX_3$, $x_2 = X_2 + kX_2$, $x_3 = X_3$, $k = 10^{-5}$.
- (a) Find the components of the strain tensor.
- (b) Find the unit elongation of an element initially in the direction of $\mathbf{e}_1 + \mathbf{e}_2$.

3.20 Consider the displacement field:

$$u_1 = k(2X_1^2 + X_1X_2), \quad u_2 = kX_2^2, \quad u_3 = 0, \quad k = 10^{-4}$$

- (a) Find the unit elongations and the change of angles for two material elements $d\mathbf{X}^{(1)} = dX_1\mathbf{e}_1$ and $d\mathbf{X}^{(2)} = dX_2\mathbf{e}_2$ that emanate from a particle designated by $\mathbf{X} = \mathbf{e}_1 + \mathbf{e}_2$.
- (b) Sketch the deformed positions of these two elements.
- 3.21** Given the displacement field $u_1 = kX_1$, $u_2 = u_3 = 0$, $k = 10^{-4}$. Determine the increase in length for the diagonal element (OA) of the unit cube (see Figure P3.1) in the direction of $\mathbf{e}_1 + \mathbf{e}_2 + \mathbf{e}_3$ (a) by using the strain tensor and (b) by geometry.

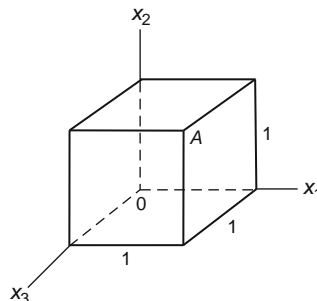

FIGURE P3.1

3.22 With reference to a rectangular Cartesian coordinate system, the state of strain at a point is given by the

$$\text{matrix } [\mathbf{E}] = \begin{bmatrix} 5 & 3 & 0 \\ 3 & 4 & -1 \\ 0 & -1 & 2 \end{bmatrix} \times 10^{-4}.$$

- (a) What is the unit elongation in the direction of $2\mathbf{e}_1 + 2\mathbf{e}_2 + \mathbf{e}_3$?
 (b) What is the change in angle between two perpendicular lines (in the undeformed state) emanating from the point and in the directions of $2\mathbf{e}_1 + 2\mathbf{e}_2 + \mathbf{e}_3$ and $3\mathbf{e}_1 - 6\mathbf{e}_3$?

3.23 For the strain tensor given in the previous problem, (a) find the unit elongation in the direction of $3\mathbf{e}_1 - 4\mathbf{e}_2$ and (b) find the change in angle between two elements in the direction of $3\mathbf{e}_1 - 4\mathbf{e}_3$ and $4\mathbf{e}_1 + 3\mathbf{e}_3$.

3.24 (a) Determine the principal scalar invariants for the strain tensor given here at left and (b) show that the matrix given at the right cannot represent the same state of strain.

$$[\mathbf{E}] = \begin{bmatrix} 5 & 3 & 0 \\ 3 & 4 & -1 \\ 0 & -1 & 2 \end{bmatrix} \times 10^{-4}, \quad \begin{bmatrix} 3 & 0 & 0 \\ 0 & 6 & 0 \\ 0 & 0 & 2 \end{bmatrix} \times 10^{-4}.$$

3.25 Calculate the principal scalar invariants for the following two tensors. What can you say about the results?

$$[\mathbf{T}^{(1)}] = \begin{bmatrix} 0 & \tau & 0 \\ \tau & 0 & 0 \\ 0 & 0 & 0 \end{bmatrix} \quad \text{and} \quad [\mathbf{T}^{(2)}] = \begin{bmatrix} 0 & -\tau & 0 \\ -\tau & 0 & 0 \\ 0 & 0 & 0 \end{bmatrix}.$$

3.26 For the displacement field $u_1 = kX_1^2$, $u_2 = kX_2X_3$, $u_3 = k(2X_1X_3 + X_1^2)$, $k = 10^{-6}$, find the maximum unit elongation for an element that is initially at $(1, 0, 0)$.

3.27 Given the matrix of an infinitesimal strain tensor as:

$$[\mathbf{E}] = \begin{bmatrix} k_1X_2 & 0 & 0 \\ 0 & -k_2X_2 & 0 \\ 0 & 0 & -k_2X_2 \end{bmatrix}.$$

- (a) Find the location of the particle that does not undergo any volume change.
 (b) What should be the relation between k_1 and k_2 so that no element changes its volume?

3.28 The displacement components for a body are $u_1 = k(X_1^2 + X_2)$, $u_2 = k(4X_3^2 - X_1)$, $u_3 = 0$, $k = 10^{-4}$.

- (a) Find the strain tensor.
 (b) Find the change of length per unit length for an element which was at $(1, 2, 1)$ and in the direction of $\mathbf{e}_1 + \mathbf{e}_2$.
 (c) What is the maximum unit elongation at the same point $(1, 2, 1)$?
 (d) What is the change of volume for the unit cube with a corner at the origin and with three of its edges along the positive coordinate axes?

3.29 For any motion, the mass of a particle (material volume) remains a constant (conservation of mass principle). Considering the mass to be the product of its volume and its mass density, show that (a) for infinitesimal deformation $\rho(1 + E_{kk}) = \rho_o$, where ρ_o denote the initial density and ρ the current density.

- (b) Use the smallness of E_{kk} to show that the current density is given by $\rho = \rho_o(1 - E_{kk})$.

3.30 True or false: At any point in a body there always exist two mutually perpendicular material elements that do not suffer any change of angle in an arbitrary small deformation of the body. Give reason(s) for this.

- 3.31** Given the following strain components at a point in a continuum: $E_{11} = E_{12} = E_{22} = k$, $E_{33} = 3k$, $E_{13} = E_{23} = 0$, $k = 10^{-6}$. Does there exist a material element at the point which decreases in length under the deformation? Explain your answer.
- 3.32** The unit elongations at a certain point on the surface of a body are measured experimentally by means of three strain gages that are arranged 45° apart (called the 45° strain rosette) in the direction of \mathbf{e}_1 , $\mathbf{e}'_1 = (\mathbf{e}_1 + \mathbf{e}_2)/\sqrt{2}$ and \mathbf{e}_2 . If these unit elongations are designated by a , b , c , respectively, what are the strain components E_{11} , E_{22} and E_{12} ?
- 3.33** (a) Do the previous problem, if the measured strains are 200×10^{-6} , 50×10^{-6} , and 100×10^{-6} in the direction \mathbf{e}_1 , \mathbf{e}'_1 and \mathbf{e}_2 , respectively. (b) Find the principal directions, assuming $E_{31} = E_{32} = E_{33} = 0$. (c) How will the result of part (b) be altered if $E_{33} \neq 0$?
- 3.34** Repeat the previous problem with $E_{11} = E'_{11} = E_{22} = 1000 \times 10^{-6}$.
- 3.35** The unit elongations at a certain point on the surface of a body are measured experimentally by means of strain gages that are arranged 60° apart (called the 60° strain rosette) in the direction of \mathbf{e}_1 , $(\mathbf{e}_1 + \sqrt{3}\mathbf{e}_2)/2$ and $(-\mathbf{e}_1 + \sqrt{3}\mathbf{e}_2)/2$. If these unit elongations are designated by a , b , c , respectively, what are the strain components E_{11} , E_{22} and E_{12} ?
- 3.36** If the 60° strain rosette measurements give $a = 2 \times 10^{-6}$, $b = 1 \times 10^{-6}$, $c = 1.5 \times 10^{-6}$, obtain E_{11} , E_{12} and E_{22} . (Use the formulas obtained in the previous problem.)
- 3.37** Repeat the previous problem for the case $a = b = c = 2000 \times 10^{-6}$.
- 3.38** For the velocity field $\mathbf{v} = kx_2^2\mathbf{e}_1$, (a) find the rate of deformation and spin tensors. (b) Find the rate of extension of a material element $d\mathbf{x} = ds\mathbf{n}$, where $\mathbf{n} = (\mathbf{e}_1 + \mathbf{e}_2)/\sqrt{2}$ at $\mathbf{x} = 5\mathbf{e}_1 + 3\mathbf{e}_2$.
- 3.39** For the velocity field $\mathbf{v} = \alpha\{(t+k)/(1+x_1)\}\mathbf{e}_1$, find the rates of extension for the following material elements: $d\mathbf{x}^{(1)} = ds_1\mathbf{e}_1$ and $d\mathbf{x}^{(2)} = (ds_2/\sqrt{2})(\mathbf{e}_1 + \mathbf{e}_2)$ at the origin at time $t = 1$.
- 3.40** For the velocity field $\mathbf{v} = (\cos t)(\sin \pi x_1)\mathbf{e}_2$, (a) find the rate of deformation and spin tensors, and (b) find the rate of extension at $t = 0$ for the following elements at the origin: $d\mathbf{x}^{(1)} = ds_1\mathbf{e}_1$, $d\mathbf{x}^{(2)} = ds_2\mathbf{e}_2$ and $d\mathbf{x}^{(3)} = (ds_3/\sqrt{2})(\mathbf{e}_1 + \mathbf{e}_2)$.
- 3.41** Show that the following velocity components correspond to a rigid body motion: $v_1 = x_2 - x_3$, $v_2 = -x_1 + x_3$, $v_3 = x_1 - x_2$.
- 3.42** Given the velocity field $\mathbf{v} = (1/r)\mathbf{e}_r$, (a) find the rate of deformation tensor and the spin tensor and (b) find the rate of extension of a radial material line element.
- 3.43** Given the two-dimensional velocity field in polar coordinates: $v_r = 0$, $v_\theta = 2r + \frac{4}{r}$. (a) Find the acceleration at $r = 2$ and (b) find the rate of deformation tensor at $r = 2$.
- 3.44** Given the velocity field in spherical coordinates: $v_r = 0$, $v_\theta = 0$, $v_\phi = \left(Ar + \frac{B}{r^2}\right)\sin \theta$. (a) Determine the acceleration field and (b) find the rate of deformation tensor.
- 3.45** A motion is said to be irrotational if the spin tensor vanishes. Show that the following velocity field is irrotational:

$$\mathbf{v} = \frac{-x_2\mathbf{e}_2 + x_1\mathbf{e}_2}{r^2}, \quad r^2 = x_1^2 + x_2^2.$$

3.46 Let $d\mathbf{x}^{(1)} = ds_1\mathbf{n}$ and $d\mathbf{x}^{(2)} = ds_2\mathbf{m}$ be two material elements that emanate from a particle P which at present has a rate of deformation \mathbf{D} .

(a) Consider $(D/Dt)(d\mathbf{x}^{(1)} \cdot d\mathbf{x}^{(2)})$ to show that

$$\left[\frac{1}{ds_1} \frac{D(ds_1)}{Dt} + \frac{1}{ds_2} \frac{D(ds_2)}{Dt} \right] \cos \theta - \sin \theta \frac{D\theta}{Dt} = 2\mathbf{m} \cdot \mathbf{D}\mathbf{n},$$

where θ is the angle between \mathbf{m} and \mathbf{n} .

(b) Consider the case of $d\mathbf{x}^{(1)} = d\mathbf{x}^{(2)}$. What does the above formula reduce to?

(c) Consider the case where $\theta = \pi/2$, i.e., $d\mathbf{x}^{(1)}$ and $d\mathbf{x}^{(2)}$ are perpendicular to each other. What does the above formula reduce to?

3.47 Let $\mathbf{e}_1, \mathbf{e}_2, \mathbf{e}_3$ and D_1, D_2, D_3 be the principal directions and the corresponding principal values of a rate of deformation tensor \mathbf{D} . Further, let $d\mathbf{x}^{(1)} = ds_1\mathbf{e}_1$, $d\mathbf{x}^{(2)} = ds_2\mathbf{e}_2$, and $d\mathbf{x}^{(3)} = ds_3\mathbf{e}_3$ be three material elements. From $(D/Dt)\{d\mathbf{x}^{(1)} \cdot d\mathbf{x}^{(2)} \times d\mathbf{x}^{(3)}\}$, show that $\frac{1}{dV} \frac{D(dV)}{Dt} = D_1 + D_2 + D_3$, where $dV = ds_1 ds_2 ds_3$.

3.48 Consider an element $d\mathbf{x} = ds\mathbf{n}$.

(a) Show that $(\mathbf{D}/Dt)\mathbf{n} = \mathbf{D}\mathbf{n} + \mathbf{W}\mathbf{n} - (\mathbf{n} \cdot \mathbf{D}\mathbf{n})\mathbf{n}$, where \mathbf{D} is the rate of deformation tensor and \mathbf{W} is the spin tensor.

(b) Show that if \mathbf{n} is an eigenvector of \mathbf{D} , then $D\mathbf{n}/Dt = \mathbf{W}\mathbf{n} = \boldsymbol{\omega} \times \mathbf{n}$.

3.49 Given the following velocity field: $v_1 = k(x_2 - 2)^2 x_3$, $v_2 = -x_1 x_2$, $v_3 = kx_1 x_3$ for an incompressible fluid, determine the value of k such that the equation of mass conservation is satisfied.

3.50 Given the velocity field in cylindrical coordinates $v_r = f(r, \theta)$, $v_\theta = v_z = 0$. For an incompressible material, from the conservation of mass principle, obtain the most general form of the function $f(r, \theta)$.

3.51 An incompressible fluid undergoes a two-dimensional motion with $v_r = k \cos \theta / \sqrt{r}$. From the consideration of the principle of conservation of mass, find v_θ , subject to the condition that $v_\theta = 0$ at $\theta = 0$.

3.52 Are the following two velocity fields isochoric (i.e., no change of volume)?

$$\mathbf{v} = \frac{x_1\mathbf{e}_1 + x_2\mathbf{e}_2}{r^2}, \quad r^2 = x_1^2 + x_2^2 \quad (\text{i})$$

and

$$\mathbf{v} = \frac{-x_2\mathbf{e}_1 + x_1\mathbf{e}_2}{r^2}, \quad r^2 = x_1^2 + x_2^2 \quad (\text{ii})$$

3.53 Given that an incompressible and inhomogeneous fluid has a density field given by $\rho = kx_2$. From the consideration of the principle of conservation of mass, find the permissible form of velocity field for a two-dimensional flow ($v_3 = 0$).

3.54 Consider the velocity field: $\mathbf{v} = \frac{\alpha x_1}{1 + kt} \mathbf{e}_1$. From the consideration of the principle of conservation of mass, (a) find the density if it depends only on time t , i.e., $\rho = \rho(t)$, with $\rho(0) = \rho_0$, and (b) find the density if it depends only on x_1 , i.e., $\rho = \hat{\rho}(x_1)$, with $\hat{\rho}(x_0) = \rho^*$.

3.55 Given the velocity field $\mathbf{v} = \alpha(x_1 t \mathbf{e}_1 + x_2 t \mathbf{e}_2)$. From the consideration of the principle of conservation of mass, determine how the fluid density varies with time if in a spatial description it is a function of time only.

3.56 Show that $\frac{\partial W_{im}}{\partial X_k} = \frac{\partial E_{ik}}{\partial X_m} - \frac{\partial E_{km}}{\partial X_i}$, where $E_{im} = \frac{1}{2} \left(\frac{\partial u_i}{\partial X_m} + \frac{\partial u_m}{\partial X_i} \right)$ is the strain tensor and

$W_{im} = \frac{1}{2} \left(\frac{\partial u_i}{\partial X_m} - \frac{\partial u_m}{\partial X_i} \right)$ is the rotation tensor.

3.57 Check whether or not the following distribution of the state of strain satisfies the compatibility conditions:

$$[\mathbf{E}] = k \begin{bmatrix} X_1 + X_2 & X_1 & X_2 \\ X_1 & X_2 + X_3 & X_3 \\ X_2 & X_3 & X_1 + X_3 \end{bmatrix}, \quad k = 10^{-4}$$

3.58 Check whether or not the following distribution of the state of strain satisfies the compatibility conditions:

$$[\mathbf{E}] = k \begin{bmatrix} X_1^2 & X_2^2 + X_3^2 & X_1 X_3 \\ X_2^2 + X_3^2 & 0 & X_1 \\ X_1 X_3 & X_1 & X_2^2 \end{bmatrix}, \quad k = 10^{-4}$$

3.59 Does the displacement field $u_1 = \sin X_1$, $u_2 = X_1^3 X_2$, $u_3 = \cos X_3$ correspond to a compatible strain field?

3.60 Given the strain field $E_{12} = E_{21} = kX_1 X_2$, $k = 10^{-4}$ and all other $E_{ij} = 0$. (a) Check the equations of compatibility for this strain field and (b) by attempting to integrate the strain field, show that there does not exist a continuous displacement field for this strain field.

3.61 Given the following strain components: $E_{11} = \frac{1}{\alpha} f(X_2, X_3)$, $E_{22} = E_{33} = -\frac{\nu}{\alpha} f(X_2, X_3)$, $E_{12} = E_{13} = E_{23} = 0$. Show that for the strains to be compatible, $f(X_2, X_3)$ must be linear in X_2 and X_3 .

3.62 In cylindrical coordinates (r, θ, z) , consider a differential volume bounded by the three pairs of faces: $r = r$ and $r = r + dr$; $\theta = \theta$ and $\theta = \theta + d\theta$; $z = z$ and $z = z + dz$. The rate at which mass is flowing into the volume across the face $r = r$ is given by $\rho v_r (r d\theta) (dz)$ and similar expressions for the other faces. By demanding that the net rate of inflow of mass must be equal to the rate of increase of mass inside the differential volume, obtain the equation of conservation of mass in cylindrical coordinates. Check your answer with Eq. (3.15.7).

3.63 Given the following deformation in rectangular Cartesian coordinates: $x_1 = 3X_3$, $x_2 = -X_1$, $x_3 = -2X_2$. Determine (a) the deformation gradient \mathbf{F} , (b) the right Cauchy-Green tensor \mathbf{C} and the right stretch tensor \mathbf{U} , (c) the left Cauchy-Green tensor \mathbf{B} , (d) the rotation tensor \mathbf{R} , (e) the Lagrangean strain tensor \mathbf{E}^* , (f) the Euler strain tensor \mathbf{e}^* , (g) the ratio of deformed volume to initial volume, and (h) the deformed area (magnitude and its normal) for the area whose normal was in the direction of \mathbf{e}_2 and whose magnitude was unity for the undeformed area.

3.64 Do the previous problem for the following deformation:

$$x_1 = 2X_2, \quad x_2 = 3X_3, \quad x_3 = X_1.$$

3.65 Do Prob. 3.63 for the following deformation:

$$x_1 = X_1, \quad x_2 = 3X_3, \quad x_3 = -2X_2.$$

3.66 Do Prob. 3.63 for the following deformation:

$$x_1 = 2X_2, \quad x_2 = -X_1, \quad x_3 = 3X_3.$$

3.67 Given $x_1 = X_1 + 3X_2$, $x_2 = X_2$, $x_3 = X_3$. Obtain (a) the deformation gradient \mathbf{F} and the right Cauchy-Green tensor \mathbf{C} , (b) the eigenvalues and eigenvector of \mathbf{C} , (c) the matrix of the stretch tensor \mathbf{U} and \mathbf{U}^{-1} with respect to the \mathbf{e}_i -basis, and (d) the rotation tensor \mathbf{R} with respect to the \mathbf{e}_i -basis.

3.68 Verify that with respect to rectangular Cartesian base vectors, the right stretch tensor \mathbf{U} and the rotation tensor \mathbf{R} for the simple shear deformation:

$$x_1 = X_1 + kX_2, \quad x_2 = X_2, \quad x_3 = X_3,$$

are given by: with $f = (1 + k^2/4)^{-1/2}$,

$$[\mathbf{U}] = \begin{bmatrix} f & kf/2 & 0 \\ kf/2 & (1 + k^2/2)f & 0 \\ 0 & 0 & 1 \end{bmatrix}, \quad [\mathbf{R}] = \begin{bmatrix} f & kf/2 & 0 \\ -kf/2 & f & 0 \\ 0 & 0 & 1 \end{bmatrix}.$$

3.69 Let $d\mathbf{X}^{(1)} = dS_1\mathbf{N}^{(1)}$, $d\mathbf{X}^{(2)} = dS_2\mathbf{N}^{(2)}$ be two material elements at a point P. Show that if θ denotes the angle between their respective deformed elements $d\mathbf{x}^{(1)} = ds_1\mathbf{m}$ and $d\mathbf{x}^{(2)} = ds_2\mathbf{n}$, then $\cos\theta = C_{\alpha\beta}N_\alpha^{(1)}N_\beta^{(2)}/\lambda_1\lambda_2$, where $\mathbf{N}^{(1)} = N_\alpha^{(1)}\mathbf{e}_\alpha$, $\mathbf{N}^{(2)} = N_\alpha^{(2)}\mathbf{e}_\alpha$, $\lambda_1 = ds_1/dS_1$ and $\lambda_2 = ds_2/dS_2$.

3.70 Given the following right Cauchy-Green deformation tensor at a point

$$[\mathbf{C}] = \begin{bmatrix} 9 & 0 & 0 \\ 0 & 4 & 0 \\ 0 & 0 & 0.36 \end{bmatrix}.$$

- (a) Find the stretch for the material elements that were in the direction of \mathbf{e}_1 , \mathbf{e}_2 and \mathbf{e}_3 .
- (b) Find the stretch for the material element that was in the direction of $\mathbf{e}_1 + \mathbf{e}_2$.
- (c) Find $\cos\theta$, where θ is the angle between $d\mathbf{x}^{(1)}$ and $d\mathbf{x}^{(2)}$ and where $d\mathbf{X}^{(1)} = dS_1\mathbf{e}_1$ and $d\mathbf{X}^{(2)} = dS_2\mathbf{e}_1$ deform into $d\mathbf{x}^{(1)} = ds_1\mathbf{m}$ and $d\mathbf{x}^{(2)} = ds_2\mathbf{n}$.

3.71 Given the following large shear deformation:

$$x_1 = X_1 + X_2, \quad x_2 = X_2, \quad x_3 = X_3.$$

- (a) Find the stretch tensor \mathbf{U} (*hint*: use the formula given in Prob. 3.68) and verify that $\mathbf{U}^2 = \mathbf{C}$, the right Cauchy-Green deformation tensor.
- (b) What is the stretch for the element that was in the direction \mathbf{e}_2 ?
- (c) Find the stretch for an element that was in the direction of $\mathbf{e}_1 + \mathbf{e}_2$.
- (d) What is the angle between the deformed elements of $dS_1\mathbf{e}_1$ and $dS_2\mathbf{e}_2$?

3.72 Given the following large shear deformation:

$$x_1 = X_1 + 2X_2, \quad x_2 = X_2, \quad x_3 = X_3.$$

- (a) Find the stretch tensor \mathbf{U} (*hint*: use the formula given in Prob. 3.68) and verify that $\mathbf{U}^2 = \mathbf{C}$, the right Cauchy-Green deformation tensor.
- (b) What is the stretch for the element that was in the direction \mathbf{e}_2 ?
- (c) Find the stretch for an element that was in the direction of $\mathbf{e}_1 + \mathbf{e}_2$.
- (d) What is the angle between the deformed elements of $dS_1\mathbf{e}_1$ and $dS_2\mathbf{e}_2$?

- 3.73** Show that for any tensor $\mathbf{A}(X_1, X_2, X_3)$, $\frac{\partial}{\partial X_m} \det \mathbf{A} = (\det \mathbf{A})(\mathbf{A}^{-1})_{nj} \frac{\partial A_{jn}}{\partial X_m}$.
- 3.74** Show that if $\mathbf{T}\mathbf{U} = 0$, where the eigenvalues of the real and symmetric tensor \mathbf{U} are all positive (non-zero), then $\mathbf{T} = 0$.
- 3.75** Derive Eq. (3.29.21), that is, $B_{\theta\theta} = \left(\frac{r\partial\theta}{\partial r_o}\right)^2 + \left(\frac{r\partial\theta}{r_o\partial\theta_o}\right)^2 + \left(\frac{r\partial\theta}{\partial z_o}\right)^2$.
- 3.76** Derive Eq. (3.29.23), i.e., $B_{rz} = \left(\frac{\partial r}{\partial r_o}\right)\left(\frac{\partial z}{\partial r_o}\right) + \left(\frac{\partial r}{r_o\partial\theta_o}\right)\left(\frac{\partial z}{r_o\partial\theta_o}\right) + \left(\frac{\partial r}{\partial z_o}\right)\left(\frac{\partial z}{\partial z_o}\right)$.
- 3.77** From $r_o = r_o(r, \theta, z, t)$, $\theta_o = \theta_o(r, \theta, z, t)$, $z_o = z_o(r, \theta, z, t)$, derive the components of \mathbf{B}^{-1} with respect to the basis at \mathbf{x} .
- 3.78** Derive Eq. (3.29.47), that is, $\mathbf{C}_{\theta_o\theta_o} = \left(\frac{\partial r}{r_o\partial\theta_o}\right)^2 + \left(\frac{r\partial\theta}{r_o\partial\theta_o}\right)^2 + \left(\frac{\partial z}{r_o\partial\theta_o}\right)^2$.
- 3.79** Derive Eq. (3.29.49), $\mathbf{C}_{r_o\theta_o} = \left(\frac{\partial r}{r_o\partial\theta_o}\right)\left(\frac{\partial r}{\partial r_o}\right) + \left(\frac{r\partial\theta}{r_o\partial\theta_o}\right)\left(\frac{r\partial\theta}{\partial r_o}\right) + \left(\frac{\partial z}{r_o\partial\theta_o}\right)\left(\frac{\partial z}{\partial r_o}\right)$.
- 3.80** Derive the components of \mathbf{C}^{-1} with respect to the bases at the reference position \mathbf{X} .
- 3.81** Derive components of \mathbf{B} with respect to the basis $\{\mathbf{e}_r, \mathbf{e}_\theta, \mathbf{e}_z\}$ at \mathbf{x} for the pathline equations given by $r = r(X, Y, Z, t)$, $\theta = \theta(X, Y, Z, t)$, $z = z(X, Y, Z, t)$.
- 3.82** Derive the components of \mathbf{B}^{-1} with respect to the basis $\{\mathbf{e}_r, \mathbf{e}_\theta, \mathbf{e}_z\}$ at \mathbf{x} for the pathline equations given by $X = X(r, \theta, z, t)$, $Y = Y(r, \theta, z, t)$, $Z = Z(r, \theta, z, t)$.
- 3.83** Verify that (a) the components of \mathbf{B} with respect to $\{\mathbf{e}_r, \mathbf{e}_\theta, \mathbf{e}_z\}$ can be obtained from $[\mathbf{F}\mathbf{F}^T]$ and (b) the component of \mathbf{C} , with respect to $\{\mathbf{e}_r^o, \mathbf{e}_\theta^o, \mathbf{e}_z^o\}$ can be obtained from $[\mathbf{F}^T\mathbf{F}]$, where $[\mathbf{F}]$ is the matrix of the two-point deformation gradient tensor given in Eq. (3.29.12).
- 3.84** Given $r = r_o$, $\theta = \theta_o + kz_o$, $z = z_o$. (a) Obtain the components of the left Cauchy-Green tensor \mathbf{B} , with respect to the basis at the current configuration (r, θ, z) . (b) Obtain the components of the right Cauchy-Green tensor \mathbf{C} with respect to the basis at the reference configuration.
- 3.85** Given $r = (2aX + b)^{1/2}$, $\theta = Y/a$, $z = Z$, where (r, θ, z) are cylindrical coordinates for the current configuration and (X, Y, Z) are rectangular coordinates for the reference configuration. (a) Obtain the components of $[\mathbf{B}]$ with respect to the basis at the current configuration and (b) calculate the change of volume.
- 3.86** Given $r = r(X)$, $\theta = g(Y)$, $z = h(Z)$, where (r, θ, z) and (X, Y, Z) are cylindrical and rectangular Cartesian coordinates with respect to the current and the reference configuration respectively. Obtain the components of the right Cauchy-Green tensor \mathbf{C} with respect to the basis at the reference configuration.

This page intentionally left blank

Stress and Integral Formulations of General Principles

In the previous chapter, we considered the purely kinematic description of the motion of a continuum without any consideration of the forces that cause the motion and deformation. In this chapter, we consider a means of describing the forces in the interior of a body idealized as a continuum. It is generally accepted that matter is formed of molecules, which in turn consist of atoms and subatomic particles. Therefore, the internal forces in real matter are those between these particles. In the classical continuum theory where matter is assumed to be continuously distributed, the forces acting at every point inside a body are introduced through the concept of body forces and surface forces. Body forces are those that act throughout a volume (e.g., gravity, electrostatic force) by a long-range interaction with matter or charges at a distance. Surface forces are those that act on a surface (real or imagined), separating parts of the body. We assume that it is adequate to describe the surface forces at a point on a surface through the definition of a *stress vector*, discussed in Section 4.1, which pays no attention to the curvature of the surface at the point. Such an assumption is known as *Cauchy's stress principle* and is one of the basic axioms of classical continuum mechanics.

4.1 STRESS VECTOR

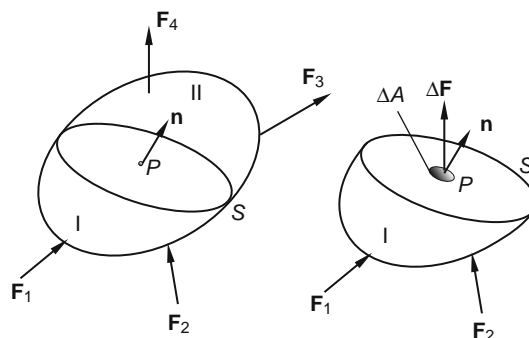

FIGURE 4.1-1

Let us consider a body depicted in Figure 4.1-1. Imagine a plane such as S , which passes through an arbitrary internal point P and which has a unit normal vector \mathbf{n} . The plane cuts the body into two portions. One portion

lies on the side of the arrow of \mathbf{n} (designated by II in the figure) and the other portion on the tail of \mathbf{n} (designated by I). Considering portion I as a free body, there will be on plane S a resultant force $\Delta\mathbf{F}$ acting on a small area ΔA containing P . We define the stress vector (acting from II to I) at the point P on the plane S as the limit of the ratio $\Delta\mathbf{F}/\Delta A$ as $\Delta A \rightarrow 0$. That is, with \mathbf{t}_n denoting the stress vector,

$$\mathbf{t}_n = \lim_{\Delta A \rightarrow 0} \frac{\Delta\mathbf{F}}{\Delta A}. \quad (4.1.1)$$

If portion II is considered as a free body, then by Newton's law of action and reaction, we shall have a stress vector (acting from I to II) \mathbf{t}_{-n} at the same point on the same plane equal and opposite to that given by Eq. (4.1.1). That is,

$$\mathbf{t}_n = -\mathbf{t}_{-n}. \quad (4.1.2)$$

The subscript $-\mathbf{n}$ for \mathbf{t} (i.e., \mathbf{t}_{-n}) indicates that outward normal for the portion II is in the negative direction of \mathbf{n} .

Next, let S be a surface (instead of a plane) passing the point P . Let $\Delta\mathbf{F}$ be the resultant force on a small area ΔS on the surface S . The *Cauchy stress vector* at P on S is defined as

$$\mathbf{t} = \lim_{\Delta S \rightarrow 0} \frac{\Delta\mathbf{F}}{\Delta S}. \quad (4.1.3)$$

We now state the following principle, known as the *Cauchy's stress principle*: The stress vector at any given place and time has a common value on all parts of material having a common tangent plane at P and lying on the same side of it. In other words, if \mathbf{n} is the unit outward normal (i.e., a vector of unit length pointing outward, away from the material) to the tangent plane, then

$$\mathbf{t} = \mathbf{t}(\mathbf{x}, t, \mathbf{n}), \quad (4.1.4)$$

where the scalar t denotes time.

In the following section, we show from Newton's second law that this dependence of the Cauchy's stress vector on the outward normal vector \mathbf{n} can be expressed as

$$\mathbf{t} = \mathbf{T}(\mathbf{x}, t)\mathbf{n}, \quad (4.1.5)$$

where \mathbf{T} is a linear transformation.

4.2 STRESS TENSOR

According to Eq. (4.1.4), the stress vector on a plane passing through a given spatial point \mathbf{x} at a given time t depends only on the unit normal vector \mathbf{n} to the plane. Thus, let \mathbf{T} be the transformation such that

$$\mathbf{t}_n = \mathbf{T}\mathbf{n}. \quad (4.2.1)$$

We wish to show that this transformation is linear. Let a small tetrahedron be isolated from the body with the point P as one of its vertices (see Figure 4.2-1). The size of the tetrahedron will ultimately be made to approach zero volume so that, in the limit, the inclined plane will pass through the point P . The outward normal to the face PAB is $-\mathbf{e}_1$. Thus, the stress vector on this face is denoted by $\mathbf{t}_{-\mathbf{e}_1}$ and the force on the face is $\mathbf{t}_{-\mathbf{e}_1}\Delta A_1$, where ΔA_1 is the area of PAB . Similarly, the force acting on PBC , PAC and the inclined face ABC are $\mathbf{t}_{-\mathbf{e}_2}\Delta A_2$, $\mathbf{t}_{-\mathbf{e}_3}\Delta A_3$, and $\mathbf{t}_n\Delta A_n$, respectively. Thus, from Newton's second law written for the tetrahedron, we have

$$\sum \mathbf{F} = \mathbf{t}_{-\mathbf{e}_1}(\Delta A_1) + \mathbf{t}_{-\mathbf{e}_2}(\Delta A_2) + \mathbf{t}_{-\mathbf{e}_3}(\Delta A_3) + \mathbf{t}_n\Delta A_n = m\mathbf{a}. \quad (4.2.2)$$

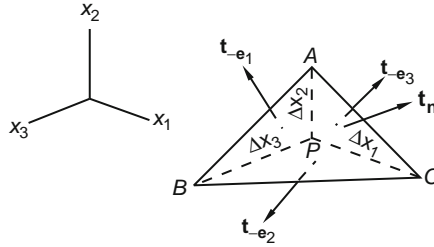

FIGURE 4.2-1

Since the mass $m = (\text{density})(\text{volume})$ and the volume of the tetrahedron is proportional to the product of three infinitesimal lengths (in fact, the volume equals $(1/6)\Delta x_1\Delta x_2\Delta x_3$), when the size of the tetrahedron approaches zero, the right-hand side of Eq. (4.2.2) will approach zero faster than the terms on the left, where the stress vectors are multiplied by areas, the product of two infinitesimal lengths. Thus, in the limit, the acceleration term drops out exactly from Eq. (4.2.2). (We note that any body force, e.g., weight, that is acting will be of the same order of magnitude as that of the acceleration term and will also drop out.) Thus,

$$\sum \mathbf{F} = \mathbf{t}_{-e_1}(\Delta A_1) + \mathbf{t}_{-e_2}(\Delta A_2) + \mathbf{t}_{-e_3}(\Delta A_3) + \mathbf{t}_n \Delta A_n = 0. \quad (4.2.3)$$

Let the unit normal vector of the inclined plane ABC be

$$\mathbf{n} = n_1 \mathbf{e}_1 + n_2 \mathbf{e}_2 + n_3 \mathbf{e}_3. \quad (4.2.4)$$

The areas ΔA_1 , ΔA_2 and ΔA_3 , being the projections of ΔA_n on the coordinate planes, are related to ΔA_n by

$$\Delta A_1 = n_1 \Delta A_n, \quad \Delta A_2 = n_2 \Delta A_n, \quad \Delta A_3 = n_3 \Delta A_n. \quad (4.2.5)$$

Using Eq. (4.2.5), Eq. (4.2.3) becomes

$$\mathbf{t}_{-e_1} n_1 + \mathbf{t}_{-e_2} n_2 + \mathbf{t}_{-e_3} n_3 + \mathbf{t}_n = 0. \quad (4.2.6)$$

But from the law of the action and reaction,

$$\mathbf{t}_{-e_1} = -\mathbf{t}_{e_1}, \quad \mathbf{t}_{-e_2} = -\mathbf{t}_{e_2}, \quad \mathbf{t}_{-e_3} = -\mathbf{t}_{e_3}, \quad (4.2.7)$$

therefore, Eq. (4.2.6) becomes

$$\mathbf{t}_n = n_1 \mathbf{t}_{e_1} + n_2 \mathbf{t}_{e_2} + n_3 \mathbf{t}_{e_3}. \quad (4.2.8)$$

Now, using Eq. (4.2.4) and Eq. (4.2.8), Eq. (4.2.1) becomes

$$\mathbf{T}(n_1 \mathbf{e}_1 + n_2 \mathbf{e}_2 + n_3 \mathbf{e}_3) = n_1 \mathbf{T} \mathbf{e}_1 + n_2 \mathbf{T} \mathbf{e}_2 + n_3 \mathbf{T} \mathbf{e}_3. \quad (4.2.9)$$

That is, the transformation \mathbf{T} , defined by

$$\mathbf{t}_n = \mathbf{T} \mathbf{n}, \quad (4.2.10)$$

is a linear transformation. It is called the *stress tensor* or the *Cauchy stress tensor*.

4.3 COMPONENTS OF STRESS TENSOR

According to Eq. (4.2.10) of the previous section, the stress vectors \mathbf{t}_{e_i} on the three coordinate planes (the e_i -planes) are related to the stress tensor \mathbf{T} by

$$\mathbf{t}_{e_1} = \mathbf{T}\mathbf{e}_1, \quad \mathbf{t}_{e_2} = \mathbf{T}\mathbf{e}_2, \quad \mathbf{t}_{e_3} = \mathbf{T}\mathbf{e}_3. \quad (4.3.1)$$

By the definition of the components of a tensor [see Eq. (2.7.2)], we have

$$\mathbf{T}\mathbf{e}_i = T_{mi}\mathbf{e}_m. \quad (4.3.2)$$

Thus,

$$\begin{aligned} \mathbf{t}_{e_1} &= T_{11}\mathbf{e}_1 + T_{21}\mathbf{e}_2 + T_{31}\mathbf{e}_3, \\ \mathbf{t}_{e_2} &= T_{12}\mathbf{e}_1 + T_{22}\mathbf{e}_2 + T_{32}\mathbf{e}_3, \\ \mathbf{t}_{e_3} &= T_{13}\mathbf{e}_1 + T_{23}\mathbf{e}_2 + T_{33}\mathbf{e}_3. \end{aligned} \quad (4.3.3)$$

Since \mathbf{t}_{e_1} is the stress vector acting on the plane whose outward normal is \mathbf{e}_1 , it is clear from the first equation of Eq. (4.3.3) that T_{11} is its normal component and T_{21} and T_{31} are its tangential components. Similarly, T_{22} is the normal component on the e_2 -plane and T_{12} and T_{32} are the tangential components on the same plane, and so on.

We note that for each stress component T_{ij} , the second index j indicates the plane on which the stress component acts and the first index indicates the direction of the component; e.g., T_{12} is the stress component in the direction of \mathbf{e}_1 acting on the plane whose outward normal is in the direction of \mathbf{e}_2 . We also note that the positive normal stresses are also known as *tensile stresses*, and negative normal stresses are known as *compressive stresses*. *Tangential stresses* are also known as *shearing stresses*. Both T_{21} and T_{31} are shearing stress components acting on the same plane (the e_1 -plane). Thus, the resultant shearing stress on this plane is given by

$$\boldsymbol{\tau}_1 = T_{21}\mathbf{e}_2 + T_{31}\mathbf{e}_3. \quad (4.3.4)$$

The magnitude of this shearing stress is given by

$$|\boldsymbol{\tau}_1| = \sqrt{T_{21}^2 + T_{31}^2}. \quad (4.3.5)$$

Similarly, on e_2 -plane,

$$\boldsymbol{\tau}_2 = T_{12}\mathbf{e}_1 + T_{32}\mathbf{e}_3, \quad (4.3.6)$$

and on e_3 -plane,

$$\boldsymbol{\tau}_3 = T_{13}\mathbf{e}_1 + T_{23}\mathbf{e}_2. \quad (4.3.7)$$

From $\mathbf{t} = \mathbf{T}\mathbf{n}$, the components of \mathbf{t} are related to those of \mathbf{T} and \mathbf{n} by the equation

$$t_i = T_{ij}n_j, \quad (4.3.8)$$

or, in a form more convenient for computation,

$$[\mathbf{t}] = [\mathbf{T}][\mathbf{n}]. \quad (4.3.9)$$

Thus, it is clear that if the matrix of \mathbf{T} is known, the stress vector \mathbf{t} on any inclined plane is uniquely determined from Eq. (4.3.9). In other words, the state of stress at a point is completely characterized by the stress tensor \mathbf{T} . Also, since \mathbf{T} is a second-order tensor, any one matrix of \mathbf{T} determines the other matrices of \mathbf{T} (see Section 2.18).

We should also note that some authors use the convention $\mathbf{t} = \mathbf{T}^T \mathbf{n}$ so that $t_{e_i} = T_{ij} e_j$. Under that convention, for example, T_{21} and T_{23} are tangential components of the stress vector on the plane whose normal is \mathbf{e}_2 , and so on. These differences in meaning regarding the nondiagonal elements of \mathbf{T} disappear if the stress tensor is symmetric.

4.4 SYMMETRY OF STRESS TENSOR: PRINCIPLE OF MOMENT OF MOMENTUM

By the use of the moment of momentum equation for a differential element, we shall now show that the stress tensor is generally a symmetric tensor.* Consider the free body diagram of a differential parallelepiped isolated from a body, as shown in Figure 4.4-1. Let us find the moment of all the forces about an axis passing through the center point A and parallel to the x_3 -axis:

$$\begin{aligned} \sum (M_A)_3 = & T_{21}(\Delta x_2)(\Delta x_3)(\Delta x_1/2) + (T_{21} + \Delta T_{21})(\Delta x_2)(\Delta x_3)(\Delta x_1/2) \\ & - T_{12}(\Delta x_1)(\Delta x_3)(\Delta x_2/2) + (T_{12} + \Delta T_{12})(\Delta x_1)(\Delta x_3)(\Delta x_2/2). \end{aligned} \quad (4.4.1)$$

In writing Eq. (4.4.1), we have assumed the absence of body moments. Dropping the terms containing small quantities of higher order, we obtain

$$\sum (M_A)_3 = (T_{21} - T_{12})(\Delta x_1)(\Delta x_2)(\Delta x_3). \quad (4.4.2)$$

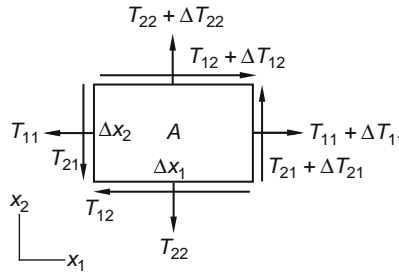

FIGURE 4.4-1

Now, whether the element is in static equilibrium or not,

$$\sum (M_A)_3 = I_{33}\alpha = 0. \quad (4.4.3)$$

This is because the angular acceleration term, $I_{33}\alpha$, is proportional to the moment of inertia I_{33} , which is given by $(1/12)(\text{density})\Delta x_1\Delta x_2\Delta x_3[(\Delta x_1)^2 + (\Delta x_2)^2]$ and is therefore a small quantity of higher order compared with the term $(T_{21} - T_{12})(\Delta x_1)(\Delta x_2)(\Delta x_3)$. Thus,

$$\sum (M_A)_3 = (T_{21} - T_{12})(\Delta x_1)(\Delta x_2)(\Delta x_3) = 0. \quad (4.4.4)$$

*See Prob. 4.29 for a case in which the stress tensor is not symmetric.

With similar derivations for the moments about the other two axes, we have

$$T_{12} = T_{21}, \quad T_{13} = T_{31}, \quad T_{23} = T_{32}. \quad (4.4.5)$$

These equations state that the stress tensor is symmetric, i.e., $\mathbf{T} = \mathbf{T}^T$. Therefore, there are only six independent stress components.

Example 4.4.1

The state of stress at a certain point is $\mathbf{T} = -p\mathbf{I}$, where p is a scalar. Show that there is no shearing stress on any plane containing this point.

Solution

The stress vector on any plane passing through the point with normal \mathbf{n} is

$$\mathbf{t}_n = \mathbf{T}\mathbf{n} = -p\mathbf{I}\mathbf{n} = -p\mathbf{n}.$$

Therefore, it is normal to the plane. This simple stress state is called a *hydrostatic state of stress*.

Example 4.4.2

With reference to a rectangular Cartesian coordinate system, the matrix of a state of stress at a certain point in a body is given by

$$[\mathbf{T}] = \begin{bmatrix} 2 & 4 & 3 \\ 4 & 0 & 0 \\ 3 & 0 & -1 \end{bmatrix} \text{ MPa.}$$

- (a) Find the stress vector and the magnitude of the normal stress on a plane that passes through the point and is parallel to the plane $x_1 + 2x_2 + 2x_3 - 6 = 0$.
- (b) If $\mathbf{e}'_1 = \frac{1}{3}(2\mathbf{e}_1 + 2\mathbf{e}_2 + \mathbf{e}_3)$ and $\mathbf{e}'_2 = \frac{1}{\sqrt{2}}(\mathbf{e}_1 - \mathbf{e}_2)$, find T'_{12} .

Solution

- (a) The plane $x_1 + 2x_2 + 2x_3 - 6 = 0$ has a unit normal given by

$$\mathbf{n} = \frac{1}{3}(\mathbf{e}_1 + 2\mathbf{e}_2 + 2\mathbf{e}_3).$$

The stress vector is obtained from Eq. (4.3.9) as

$$[\mathbf{t}] = [\mathbf{T}][\mathbf{n}] = \frac{1}{3} \begin{bmatrix} 2 & 4 & 3 \\ 4 & 0 & 0 \\ 3 & 0 & -1 \end{bmatrix} \begin{bmatrix} 1 \\ 2 \\ 2 \end{bmatrix} = \frac{1}{3} \begin{bmatrix} 16 \\ 4 \\ 1 \end{bmatrix},$$

or

$$\mathbf{t} = \frac{1}{3}(16\mathbf{e}_1 + 4\mathbf{e}_2 + \mathbf{e}_3) \text{ MPa.}$$

The magnitude of the normal stress is, with $T_n \equiv T_{(n)(n)}$,

$$T_n = \mathbf{t} \cdot \mathbf{n} = \frac{1}{9}(16 + 8 + 2) = 2.89 \text{ MPa.}$$

(b) To find the primed components of the stress tensor, we have

$$T'_{12} = \mathbf{e}'_1 \cdot \mathbf{T} \mathbf{e}'_2 = \frac{1}{3\sqrt{2}} [2 \ 2 \ 1] \begin{bmatrix} 2 & 4 & 3 \\ 4 & 0 & 0 \\ 3 & 0 & -1 \end{bmatrix} \begin{bmatrix} 1 \\ -1 \\ 0 \end{bmatrix} = \frac{7}{3\sqrt{2}} = 1.65 \text{ MPa.}$$

Example 4.4.3

The distribution of stress inside a body is given by the matrix

$$[\mathbf{T}] = \begin{bmatrix} -\rho + \rho gy & 0 & 0 \\ 0 & -\rho + \rho gy & 0 \\ 0 & 0 & -\rho + \rho gy \end{bmatrix},$$

where ρ , ρ , and g are constants. Figure 4.4-2(a) shows a rectangular block inside the body.

- (a) What is the distribution of the stress vector on the six faces of the block?
 (b) Find the total resultant force acting on the face $y = 0$ and $x = 0$.

Solution

(a) From $\mathbf{t} = \mathbf{T}\mathbf{n}$, we have

$$\begin{aligned} \text{On } x = 0, \quad [\mathbf{n}] &= [-1 \ 0 \ 0], & [\mathbf{t}] &= [\rho - \rho gy \quad 0 \quad 0], \\ \text{On } x = a, \quad [\mathbf{n}] &= [+1 \ 0 \ 0], & [\mathbf{t}] &= [-\rho + \rho gy \quad 0 \quad 0], \\ \text{On } y = 0, \quad [\mathbf{n}] &= [0 \ -1 \ 0], & [\mathbf{t}] &= [0 \quad \rho \quad 0], \\ \text{On } y = b, \quad [\mathbf{n}] &= [0 \ +1 \ 0], & [\mathbf{t}] &= [0 \quad -\rho + \rho gb \quad 0], \\ \text{On } z = 0, \quad [\mathbf{n}] &= [0 \ 0 \ -1], & [\mathbf{t}] &= [0 \quad 0 \quad \rho - \rho gy], \\ \text{On } z = c, \quad [\mathbf{n}] &= [0 \ 0 \ +1], & [\mathbf{t}] &= [0 \quad 0 \quad -\rho + \rho gy]. \end{aligned}$$

The distribution of the stress vector on four faces of the cube is shown in Figure 4.4-2(b).

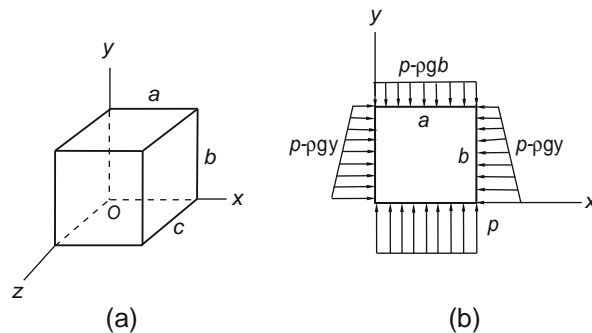

FIGURE 4.4-2

(b) On the face $y = 0$, the resultant force is

$$\mathbf{F}_1 = \int \mathbf{t} dA = \left(p \int dA \right) \mathbf{e}_2 = p a c \mathbf{e}_2.$$

On the face $x = 0$, the resultant force is

$$\mathbf{F}_2 = \left[\int (p - \rho g y) dA \right] \mathbf{e}_1 = \left[\int p dA - \rho g \int y dA \right] \mathbf{e}_1.$$

The second integral can be evaluated directly by replacing dA by $c dy$ and integrating from $y = 0$ to $y = b$. Or, since $\int y dA$ is the first moment of the face area about the z -axis, it is therefore equal to the product of the centroidal distance and the total area. Thus,

$$\mathbf{F}_2 = \left[p b c - \frac{\rho g b^2 c}{2} \right] \mathbf{e}_1.$$

4.5 PRINCIPAL STRESSES

From Section 2.23, we know that for any real symmetric stress tensor, there exist at least three mutually perpendicular principal directions (the eigenvectors of \mathbf{T}). The planes having these directions as their normals are known as the *principal planes*. On these planes, the stress vector is normal to the plane (i.e., no shearing stresses) and the normal stresses are known as the *principal stresses*. Thus, the principal stresses (eigenvalues of \mathbf{T}) include the maximum and the minimum values of normal stresses among all planes passing through a given point.

The principal stresses are to be obtained from the characteristic equation of \mathbf{T} , which may be written:

$$\lambda^3 - I_1 \lambda^2 + I_2 \lambda - I_3 = 0, \quad (4.5.1)$$

where

$$\begin{aligned} I_1 &= T_{11} + T_{22} + T_{33}, \\ I_2 &= \begin{vmatrix} T_{11} & T_{12} \\ T_{21} & T_{22} \end{vmatrix} + \begin{vmatrix} T_{11} & T_{13} \\ T_{31} & T_{33} \end{vmatrix} + \begin{vmatrix} T_{22} & T_{23} \\ T_{32} & T_{33} \end{vmatrix}, \\ I_3 &= \det \mathbf{T}, \end{aligned} \quad (4.5.2)$$

are the three principal scalar invariants of the stress tensor. For the computations of these principal directions, refer to Section 2.22.

4.6 MAXIMUM SHEARING STRESSES

In this section, we show that the maximum shearing stress is equal to one-half the difference between the maximum and the minimum principal stresses and acts on the plane that bisects the right angle between the plane of maximum principal stress and the plane of minimum principal stress.

Let \mathbf{e}_1 , \mathbf{e}_2 and \mathbf{e}_3 be the principal directions of \mathbf{T} and let T_1 , T_2 and T_3 be the principal stresses. If $\mathbf{n} = n_1\mathbf{e}_1 + n_2\mathbf{e}_2 + n_3\mathbf{e}_3$ is the unit normal to a plane, the components of the stress vector on the plane is given by

$$\begin{bmatrix} t_1 \\ t_2 \\ t_3 \end{bmatrix} = \begin{bmatrix} T_1 & 0 & 0 \\ 0 & T_2 & 0 \\ 0 & 0 & T_3 \end{bmatrix} \begin{bmatrix} n_1 \\ n_2 \\ n_3 \end{bmatrix} = \begin{bmatrix} T_1 n_1 \\ T_2 n_2 \\ T_3 n_3 \end{bmatrix}, \quad (4.6.1)$$

i.e.,

$$\mathbf{t} = n_1 T_1 \mathbf{e}_1 + n_2 T_2 \mathbf{e}_2 + n_3 T_3 \mathbf{e}_3, \quad (4.6.2)$$

and the normal stress on the same plane is given by

$$T_n = \mathbf{n} \cdot \mathbf{t} = n_1^2 T_1 + n_2^2 T_2 + n_3^2 T_3. \quad (4.6.3)$$

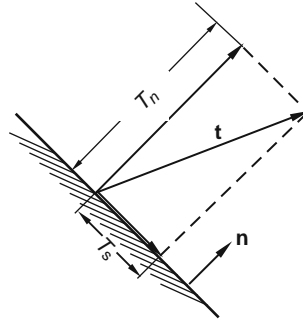

FIGURE 4.6-1

Thus, if T_s denotes the magnitude of the total shearing stress on the plane, we have (see Figure 4.6-1)

$$T_s^2 = |\mathbf{t}|^2 - T_n^2, \quad (4.6.4)$$

i.e.,

$$T_s^2 = T_1^2 n_1^2 + T_2^2 n_2^2 + T_3^2 n_3^2 - (T_1 n_1^2 + T_2 n_2^2 + T_3 n_3^2)^2. \quad (4.6.5)$$

For a given set of values of (T_1, T_2, T_3) , we would like to find the maximum value of shearing stress T_s and the plane(s), described by (n_1, n_2, n_3) , on which it acts. Looking at Eq. (4.6.5), it is clear that working with T_s^2 is easier than working with T_s . For known values of (T_1, T_2, T_3) , Eq. (4.6.5) states that T_s^2 is a function of n_1 , n_2 and n_3 , i.e.,

$$T_s^2 = f(n_1, n_2, n_3). \quad (4.6.6)$$

We wish to find the triples (n_1, n_2, n_3) for which the value of the function f is a maximum, subject to the constraint that

$$n_1^2 + n_2^2 + n_3^2 = 1. \quad (4.6.7)$$

Once the maximum value of T_s^2 is obtained, the maximum value of T_s is also obtained. We also note that when $(n_1, n_2, n_3) = (\pm 1, 0, 0)$, or $(0, \pm 1, 0)$, or $(0, 0, \pm 1)$, Eq. (4.6.5) gives $T_s = 0$. This is simply because

these are principal planes on which the shearing stress is zero. Clearly, $T_s = 0$ is the minimum value for the function in Eq. (4.6.5).

Taking the total derivative of the function in Eq. (4.6.6), we obtain, for stationary values of T_s^2 ,

$$dT_s^2 = \frac{\partial T_s^2}{\partial n_1} dn_1 + \frac{\partial T_s^2}{\partial n_2} dn_2 + \frac{\partial T_s^2}{\partial n_3} dn_3 = 0. \quad (4.6.8)$$

If dn_1 , dn_2 and dn_3 can vary independently of one another, then Eq. (4.6.8) gives the familiar condition for the determination of the triple (n_1, n_2, n_3) for the stationary value of T_s^2 ,

$$\frac{\partial T_s^2}{\partial n_1} = 0, \quad \frac{\partial T_s^2}{\partial n_2} = 0, \quad \frac{\partial T_s^2}{\partial n_3} = 0. \quad (4.6.9)$$

But dn_1 , dn_2 and dn_3 cannot vary independently. Indeed, taking the total derivative of Eq. (4.6.7), i.e., $n_1^2 + n_2^2 + n_3^2 = 1$, we obtain

$$n_1 dn_1 + n_2 dn_2 + n_3 dn_3 = 0. \quad (4.6.10)$$

Comparing Eq. (4.6.10) with Eq. (4.6.8), we arrive at the following equations:

$$\frac{\partial T_s^2}{\partial n_1} = \lambda n_1, \quad \frac{\partial T_s^2}{\partial n_2} = \lambda n_2, \quad \frac{\partial T_s^2}{\partial n_3} = \lambda n_3. \quad (4.6.11)$$

The three equations in Eq. (4.6.11), together with the equation $n_1^2 + n_2^2 + n_3^2 = 1$ [i.e., Eq. (4.6.7)], are four equations for the determination of the four unknowns n_1 , n_2 , n_3 and λ . The multiplier λ is known as the *Lagrange multiplier*, and this method of determining the stationary value of a function subject to a constraint is known as the *Lagrange multiplier method*.

Using Eq. (4.6.5), we have, from Eqs. (4.6.11),

$$2n_1 [T_1^2 - 2(T_1 n_1^2 + T_2 n_2^2 + T_3 n_3^2) T_1] = n_1 \lambda, \quad (4.6.12)$$

$$2n_2 [T_2^2 - 2(T_1 n_1^2 + T_2 n_2^2 + T_3 n_3^2) T_2] = n_2 \lambda, \quad (4.6.13)$$

$$2n_3 [T_3^2 - 2(T_1 n_1^2 + T_2 n_2^2 + T_3 n_3^2) T_3] = n_3 \lambda. \quad (4.6.14)$$

The four nonlinear algebraic equations, Eqs. (4.6.12), (4.6.13), (4.6.14), and (4.6.7), for the four unknowns $(n_1, n_2, n_3, \lambda)^\dagger$ have many sets of solution for a given set of values of (T_1, T_2, T_3) . Corresponding to each set of solution, the stationary value T_s^2 , on the plane whose normal is given by (n_1, n_2, n_3) , can be obtained from Eq. (4.6.5), i.e.,

$$T_s^2 = T_1^2 n_1^2 + T_2^2 n_2^2 + T_3^2 n_3^2 - (T_1 n_1^2 + T_2 n_2^2 + T_3 n_3^2)^2.$$

Among the stationary values will be the maximum and the minimum values of T_s^2 . Table 4.1 summarizes the solutions. (See Appendix 4.1 for details.)

We note that $(n_1, n_2, 0)$ and $(-n_1, -n_2, 0)$ represent the same plane. On the other hand, $(n_1, n_2, 0)$ and $(n_1, -n_2, 0)$ are two distinct planes that are perpendicular to each other. Thus, although there are mathematically 18 sets of roots, there are only nine distinct planes.

[†]The value of the Lagrangean multiplier λ does not have any significance and can be simply ignored once the solutions to the system of equations are obtained.

Table 4.1 Stationary Values of T_s^2 and the Corresponding Planes

(n_1, n_2, n_3) , $\mathbf{n} = n_1\mathbf{e}_1 + n_2\mathbf{e}_2 + n_3\mathbf{e}_3$, $(\mathbf{e}_1, \mathbf{e}_2, \mathbf{e}_3)$ Are Principal Directions	The Plane	Stationary Value of T_s^2
$(1, 0, 0)$ and $(-1, 0, 0)$, i.e., $\mathbf{n} = \pm\mathbf{e}_1$	\mathbf{e}_1 -plane	0
$(0, 1, 0)$ and $(0, -1, 0)$ i.e., $\mathbf{n} = \pm\mathbf{e}_2$	\mathbf{e}_2 -plane	0
$(0, 0, 1)$ and $(0, 0, -1)$ i.e., $\mathbf{n} = \pm\mathbf{e}_3$	\mathbf{e}_3 -plane	0
$(1/\sqrt{2})(1, 1, 0)$ and $(1/\sqrt{2})(-1, -1, 0)$ i.e., $\mathbf{n} = \pm(1/\sqrt{2})(\mathbf{e}_1 + \mathbf{e}_2)$	The plane bisects \mathbf{e}_1 -plane and \mathbf{e}_2 -plane in the first and third quadrant	$\left(\frac{T_1 - T_2}{2}\right)^2$
$(1/\sqrt{2})(1, -1, 0)$ and $(1/\sqrt{2})(-1, 1, 0)$ i.e., $\mathbf{n} = \pm(1/\sqrt{2})(\mathbf{e}_1 - \mathbf{e}_2)$	The plane bisects \mathbf{e}_1 -plane and \mathbf{e}_2 -plane in the second and fourth quadrant	$\left(\frac{T_1 - T_2}{2}\right)^2$
$(1/\sqrt{2})(1, 0, 1)$ and $(1/\sqrt{2})(-1, 0, -1)$ i.e., $\mathbf{n} = \pm(1/\sqrt{2})(\mathbf{e}_1 + \mathbf{e}_3)$	The plane bisects \mathbf{e}_1 -plane and \mathbf{e}_3 -plane in the first and third quadrant	$\left(\frac{T_1 - T_3}{2}\right)^2$
$(1/\sqrt{2})(1, 0, -1)$ and $(1/\sqrt{2})(-1, 0, 1)$ i.e., $\mathbf{n} = \pm(1/\sqrt{2})(\mathbf{e}_1 - \mathbf{e}_3)$	The plane bisects \mathbf{e}_1 -plane and \mathbf{e}_3 -plane in the second and fourth quadrant	$\left(\frac{T_1 - T_3}{2}\right)^2$
$(1/2)(0, 1, 1)$ and $(1/2)(0, -1, -1)$ i.e., $\mathbf{n} = \pm(1/\sqrt{2})(\mathbf{e}_2 + \mathbf{e}_3)$	The plane bisects \mathbf{e}_2 -plane and \mathbf{e}_3 -plane in the first and third quadrant	$\left(\frac{T_2 - T_3}{2}\right)^2$
$(1/\sqrt{2})(0, 1, -1)$ and $(1/\sqrt{2})(0, -1, 1)$ i.e., $\mathbf{n} = \pm(1/\sqrt{2})(\mathbf{e}_2 - \mathbf{e}_3)$	The plane bisects \mathbf{e}_2 -plane and \mathbf{e}_3 -plane in the second and fourth quadrant	$\left(\frac{T_2 - T_3}{2}\right)^2$

Three of the planes are the principal planes, on each of which the shearing stress is zero (as it should be), which is the minimum value of the magnitude of shearing stress. The other six planes in general have nonzero shearing stresses. We also note from the third column of the table that those two planes that are perpendicular to each other have the same magnitude of shearing stresses. This is because the stress tensor is symmetric. The values of T_s^2 given in the third column are the stationary values T_s^2 , of which zero is the minimum. The maximum value of T_s^2 is the maximum of the values in the third column. Thus, the maximum magnitude of shearing stress is given by the maximum of the following three values:

$$\frac{|T_1 - T_2|}{2}, \quad \frac{|T_1 - T_3|}{2}, \quad \frac{|T_2 - T_3|}{2}. \quad (4.6.15)$$

In other words,

$$(T_s)_{\max} = \frac{(T_n)_{\max} - (T_n)_{\min}}{2}, \quad (4.6.16)$$

where $(T_n)_{\max}$ and $(T_n)_{\min}$ are the largest and the smallest normal stresses, respectively. The two mutually perpendicular planes, on which this maximum shearing stress acts, bisect the planes of the largest and the smallest normal stress.

It can also be shown that on the plane of maximum shearing stress, the normal stress is

$$T_n = \frac{(T_n)_{\max} + (T_n)_{\min}}{2}. \quad (4.6.17)$$

If two of the principal stresses are equal, say, $T_1 = T_2 \neq T_3$, then, in addition to the solutions listed in the table, infinitely many other solutions can be obtained by rotating \mathbf{e}_1 and \mathbf{e}_2 axes about the \mathbf{e}_3 axis. Their stationary values of T_s , however, remain the same as those before the rotation. Finally, if $T_1 = T_2 = T_3$, then there is zero shearing stress on all the planes.

Example 4.6.1

If the state of stress is such that the components T_{13} , T_{23} and T_{33} are equal to zero, it is called a *state of plane stress*. (a) For this state of plane stress, find the principal values and the corresponding principal directions. (b) Determine the maximum shearing stress.

Solution

(a) For the stress matrix

$$[\mathbf{T}] = \begin{bmatrix} T_{11} & T_{12} & 0 \\ T_{21} & T_{22} & 0 \\ 0 & 0 & 0 \end{bmatrix}, \quad (4.6.18)$$

the characteristic equation is

$$\lambda[\lambda^2 - (T_{11} + T_{22})\lambda + (T_{11}T_{22} - T_{12}^2)] = 0. \quad (4.6.19)$$

Therefore, $\lambda = 0$ is an eigenvalue and its corresponding eigenvector is obviously $\mathbf{n} = \mathbf{e}_3$. The remaining eigenvalues are

$$\begin{cases} T_1 \\ T_2 \end{cases} = \frac{(T_{11} + T_{22}) \pm \sqrt{(T_{11} - T_{22})^2 + 4T_{12}^2}}{2}. \quad (4.6.20)$$

To find the corresponding eigenvectors, we set $(T_{ij} - \lambda\delta_{ij})n_j = 0$ and obtain, for either $\lambda = T_1$ or T_2 ,

$$\begin{aligned} (T_{11} - \lambda)n_1 + T_{12}n_2 &= 0 \\ T_{12}n_1 + (T_{22} - \lambda)n_2 &= 0 \\ (0 - \lambda)n_3 &= 0 \end{aligned} \quad (4.6.21)$$

The last equation gives $n_3 = 0$. Let $\mathbf{n} = \cos \theta \mathbf{e}_1 + \sin \theta \mathbf{e}_2$ (see Figure 4.6-2); then, from the first of Eq. (4.6.21), we have

$$\tan \theta = \frac{n_2}{n_1} = -\frac{T_{11} - \lambda}{T_{12}} \quad (4.6.22)$$

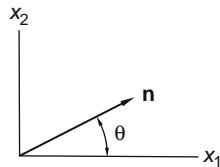

FIGURE 4.6-2

(b) Since the third eigenvalue T_3 is zero, the maximum shearing stress will be the greatest of the following three values:

$$\frac{|T_1|}{2}, \quad \frac{|T_2|}{2}, \quad \text{and} \quad \left| \frac{T_1 - T_2}{2} \right| = \frac{\sqrt{(T_{11} - T_{22})^2 + 4T_{12}^2}}{2} \quad (4.6.23)$$

Example 4.6.2

Do the previous example for the following state of stress: $T_{12} = T_{21} = 1000 \text{ MPa}$. All other T_{ij} are zero.

Solution

From Eq. (4.6.20), we have

$$\begin{cases} T_1 \\ T_2 \end{cases} = \pm \frac{\sqrt{4(1000)^2}}{2} = \pm 1000 \text{ MPa}$$

Corresponding to the maximum normal stress $T_1 = 1000 \text{ MPa}$, Eq. (4.6.22) gives

$$\tan \theta_1 = -\frac{0 - 1000}{1000} = +1, \text{ i.e., } \theta_1 = 45^\circ,$$

and corresponding to the minimum normal stress $T_2 = -1000 \text{ MPa}$ (i.e., maximum compressive stress),

$$\tan \theta_2 = -\frac{0 - (-1000)}{1000} = -1, \text{ i.e., } \theta_2 = -45^\circ.$$

The maximum shearing stress is given by

$$(T_s)_{\max} = \frac{1000 - (-1000)}{2} = 1000 \text{ MPa},$$

which acts on the plane bisecting the planes of maximum and minimum normal stress, i.e., it acts on the \mathbf{e}_1 -plane and the \mathbf{e}_2 -plane.

Example 4.6.3

Given $[\mathbf{T}] = \begin{bmatrix} 100 & 0 & 0 \\ 0 & 100 & 0 \\ 0 & 0 & 500 \end{bmatrix} \text{ MPa}$, Determine the maximum shearing stress and the planes on which it acts.

Solution

Here we have $T_1 = T_2 = 100 \text{ MPa}$, $T_3 = 500 \text{ MPa}$. Thus, the maximum shearing stress is

$$T_s = \frac{500 - 100}{2} = 200 \text{ MPa}.$$

The planes on which it acts include not only the four planes $(\mathbf{e}_1 \pm \mathbf{e}_3)/\sqrt{2}$ and $(\mathbf{e}_2 \pm \mathbf{e}_3)/\sqrt{2}$ but also any plane $\left(n_1 \mathbf{e}_1 + n_2 \mathbf{e}_2 \pm \frac{1}{\sqrt{2}} \mathbf{e}_3 \right)$, where $n_1^2 + n_2^2 + \frac{1}{2} = 1$. In other words, these planes are tangent to the conical surface of the right circular cone, with \mathbf{e}_3 as its axis and with an angle of 45° between the generatrix and the axis.

4.7 EQUATIONS OF MOTION: PRINCIPLE OF LINEAR MOMENTUM

In this section, we derive the differential equations of motion for any continuum in motion. The basic postulate is that each particle of the continuum must satisfy Newton's law of motion.

Figure 4.7-1 shows the stress vectors that act on the six faces of a small rectangular element isolated from the continuum in the neighborhood of the position designated by x_i .

Let $\mathbf{B} = B_i \mathbf{e}_i$ be the body force (such as weight) per unit mass, ρ be the mass density at x_i , and \mathbf{a} be the acceleration of a particle currently at the position x_i ; then Newton's law of motion takes the form, valid in rectangular Cartesian coordinate systems,

$$\begin{aligned} & \{\mathbf{t}_{\mathbf{e}_1}(x_1 + \Delta x_1, x_2, x_3) + \mathbf{t}_{-\mathbf{e}_1}(x_1, x_2, x_3)\}(\Delta x_2 \Delta x_3) + \{\mathbf{t}_{\mathbf{e}_2}(x_1, x_2 + \Delta x_2, x_3) + \mathbf{t}_{-\mathbf{e}_2}(x_1, x_2, x_3)\}(\Delta x_1 \Delta x_3) \\ & + \{\mathbf{t}_{\mathbf{e}_3}(x_1, x_2, x_3 + \Delta x_3) + \mathbf{t}_{-\mathbf{e}_3}(x_1, x_2, x_3)\}(\Delta x_1 \Delta x_2) + \rho \mathbf{B} \Delta x_1 \Delta x_2 \Delta x_3 = (\rho \Delta x_1 \Delta x_2 \Delta x_3) \mathbf{a}. \end{aligned} \quad (i)$$

Since $\mathbf{t}_{-\mathbf{e}_1} = -\mathbf{t}_{\mathbf{e}_1}$,

$$\mathbf{t}_{\mathbf{e}_1}(x_1 + \Delta x_1, x_2, x_3) + \mathbf{t}_{-\mathbf{e}_1}(x_1, x_2, x_3) = \left\{ \frac{\mathbf{t}_{\mathbf{e}_1}(x_1 + \Delta x_1, x_2, x_3) - \mathbf{t}_{\mathbf{e}_1}(x_1, x_2, x_3)}{\Delta x_1} \right\} \Delta x_1. \quad (ii)$$

Similarly,

$$\{\mathbf{t}_{\mathbf{e}_2}(x_1, x_2 + \Delta x_2, x_3) + \mathbf{t}_{-\mathbf{e}_2}(x_1, x_2, x_3)\} = \left\{ \frac{\mathbf{t}_{\mathbf{e}_2}(x_1, x_2 + \Delta x_2, x_3) - \mathbf{t}_{\mathbf{e}_2}(x_1, x_2, x_3)}{\Delta x_2} \right\} \Delta x_2, \text{ etc.} \quad (iii)$$

Thus, Eq. (i) becomes

$$\begin{aligned} & \left\{ \frac{\mathbf{t}_{\mathbf{e}_1}(x_1 + \Delta x_1, x_2, x_3) - \mathbf{t}_{\mathbf{e}_1}(x_1, x_2, x_3)}{\Delta x_1} \right\} + \left\{ \frac{\mathbf{t}_{\mathbf{e}_2}(x_1, x_2 + \Delta x_2, x_3) - \mathbf{t}_{\mathbf{e}_2}(x_1, x_2, x_3)}{\Delta x_2} \right\} \\ & + \left\{ \frac{\mathbf{t}_{\mathbf{e}_3}(x_1, x_2, x_3 + \Delta x_3) - \mathbf{t}_{\mathbf{e}_3}(x_1, x_2, x_3)}{\Delta x_3} \right\} + \rho \mathbf{B} = \rho \mathbf{a}. \end{aligned} \quad (4.7.1)$$

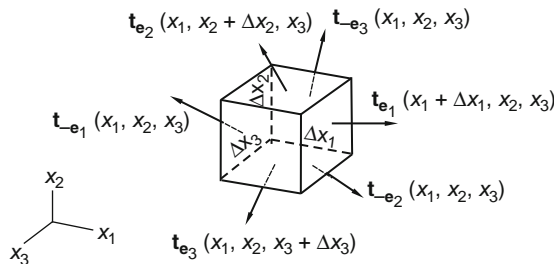

FIGURE 4.7-1

Letting $\Delta x_i \rightarrow 0$, we obtain from the preceding equation,

$$\frac{\partial \mathbf{t}_{\mathbf{e}_1}}{\partial x_1} + \frac{\partial \mathbf{t}_{\mathbf{e}_2}}{\partial x_2} + \frac{\partial \mathbf{t}_{\mathbf{e}_3}}{\partial x_3} + \rho \mathbf{B} = \rho \mathbf{a} \quad \text{or} \quad \frac{\partial \mathbf{t}_{\mathbf{e}_i}}{\partial x_j} + \rho B_j \mathbf{e}_j = \rho a_i \mathbf{e}_i. \quad (4.7.2)$$

Since $\mathbf{t}_{e_j} = \mathbf{T}e_j = T_{ij}e_i$, we have (noting that all e_i are of fixed directions in Cartesian coordinates)

$$\frac{\partial T_{ij}}{\partial x_j} e_i + \rho B_i e_i = \rho a_i e_i. \quad (4.7.3)$$

In invariant form, the preceding equation is

$$\operatorname{div} \mathbf{T} + \rho \mathbf{B} = \rho \mathbf{a}, \quad (4.7.4)$$

and in Cartesian component form

$$\frac{\partial T_{ij}}{\partial x_j} + \rho B_i = \rho a_i. \quad (4.7.5)$$

These are the equations that must be satisfied for any continuum in motion, whether it is a solid or a fluid. They are called *Cauchy's equations of motion*. If the acceleration vanishes, then Eq. (4.7.5) reduces to the static equilibrium equation:

$$\frac{\partial T_{ij}}{\partial x_j} + \rho B_i = 0. \quad (4.7.6)$$

Example 4.7.1

In the absence of body forces, does the following stress distribution satisfy the equations of equilibrium? In these equations ν is a constant.

$$\begin{aligned} T_{11} &= x_2^2 + \nu(x_1^2 - x_2^2), & T_{12} &= -2\nu x_1 x_2, & T_{22} &= x_1^2 + \nu(x_2^2 - x_1^2), \\ T_{23} &= T_{13} = 0, & T_{33} &= \nu(x_1^2 + x_2^2). \end{aligned}$$

Solution

We have

$$\begin{aligned} \frac{\partial T_{1j}}{\partial x_j} &= \frac{\partial T_{11}}{\partial x_1} + \frac{\partial T_{12}}{\partial x_2} + \frac{\partial T_{13}}{\partial x_3} = 2\nu x_1 - 2\nu x_1 + 0 = 0, \\ \frac{\partial T_{2j}}{\partial x_j} &= \frac{\partial T_{21}}{\partial x_1} + \frac{\partial T_{22}}{\partial x_2} + \frac{\partial T_{23}}{\partial x_3} = -2\nu x_2 + 2\nu x_2 + 0 = 0, \end{aligned}$$

and

$$\frac{\partial T_{3j}}{\partial x_j} = \frac{\partial T_{31}}{\partial x_1} + \frac{\partial T_{32}}{\partial x_2} + \frac{\partial T_{33}}{\partial x_3} = 0 + 0 + 0 = 0.$$

Therefore, the given stress distribution does satisfy the equilibrium equations.

Example 4.7.2

Write the equations of motion for the case where the stress components have the form $T_{ij} = -\rho \delta_{ij}$, where $\rho = \rho(x_1, x_2, x_3, t)$.

Solution

For the given T_{ij} ,

$$\frac{\partial T_{ij}}{\partial x_j} = -\frac{\partial \rho}{\partial x_j} \delta_{ij} = -\frac{\partial \rho}{\partial x_i}.$$

Therefore, from Eq. (4.7.6), we have

$$-\frac{\partial \rho}{\partial X_i} + \rho B_i = \rho a_i, \quad (4.7.7)$$

or

$$-\nabla \rho + \rho \mathbf{B} = \rho \mathbf{a}. \quad (4.7.8)$$

4.8 EQUATIONS OF MOTION IN CYLINDRICAL AND SPHERICAL COORDINATES

In Chapter 2, we presented the components of $\text{div } \mathbf{T}$ in cylindrical and in spherical coordinates. Using those formulas [Eqs. (2.34.8) to (2.34.10) and Eqs. (2.35.33) to (2.35.35)], we have the following equations of motion (see also Prob. 4.36).

Cylindrical coordinates:

$$\frac{\partial T_{rr}}{\partial r} + \frac{1}{r} \frac{\partial T_{r\theta}}{\partial \theta} + \frac{T_{rr} - T_{\theta\theta}}{r} + \frac{\partial T_{rz}}{\partial z} + \rho B_r = \rho a_r, \quad (4.8.1)$$

$$\frac{\partial T_{\theta r}}{\partial r} + \frac{1}{r} \frac{\partial T_{\theta\theta}}{\partial \theta} + \frac{T_{r\theta} + T_{\theta r}}{r} + \frac{\partial T_{\theta z}}{\partial z} + \rho B_\theta = \rho a_\theta, \quad (4.8.2)$$

$$\frac{\partial T_{zr}}{\partial r} + \frac{1}{r} \frac{\partial T_{z\theta}}{\partial \theta} + \frac{\partial T_{zz}}{\partial z} + \frac{T_{zr}}{r} + \rho B_z = \rho a_z. \quad (4.8.3)$$

For symmetric stress tensors, $T_{r\theta} + T_{\theta r} = 2T_{r\theta}$ in Eq. (4.8.2).

Spherical coordinates:

$$\frac{1}{r^2} \frac{\partial(r^2 T_{rr})}{\partial r} + \frac{1}{r \sin \theta} \frac{\partial(T_{r\theta} \sin \theta)}{\partial \theta} + \frac{1}{r \sin \theta} \frac{\partial T_{r\phi}}{\partial \phi} - \frac{T_{\theta\theta} + T_{\phi\phi}}{r} + \rho B_r = \rho a_r, \quad (4.8.4)$$

$$\frac{1}{r^3} \frac{\partial(r^3 T_{\theta r})}{\partial r} + \frac{1}{r \sin \theta} \frac{\partial(T_{\theta\theta} \sin \theta)}{\partial \theta} + \frac{1}{r \sin \theta} \frac{\partial T_{\theta\phi}}{\partial \phi} + \frac{T_{r\theta} - T_{\theta r} - T_{\phi\phi} \cot \theta}{r} + \rho B_\theta = \rho a_\theta, \quad (4.8.5)$$

$$\frac{1}{r^3} \frac{\partial(r^3 T_{\phi r})}{\partial r} + \frac{1}{r \sin \theta} \frac{\partial(T_{\phi\theta} \sin \theta)}{\partial \theta} + \frac{1}{r \sin \theta} \frac{\partial T_{\phi\phi}}{\partial \phi} + \frac{T_{r\phi} - T_{\phi r} + T_{\theta\phi} \cot \theta}{r} + \rho B_\phi = \rho a_\phi. \quad (4.8.6)$$

For symmetric stress tensors, $T_{r\theta} - T_{\theta r} = 0$ and $T_{r\phi} - T_{\phi r} = 0$ in the preceding equations.

Example 4.8.1

The stress field for the problem of an infinite elastic space loaded by a concentrated force at the origin (the Kelvin problem) is given by the following stress distribution in cylindrical coordinates:

$$\begin{aligned} T_{rr} &= A \left(\frac{z}{R^3} - \frac{3r^2 z}{R^5} \right), & T_{\theta\theta} &= \frac{Az}{R^3}, & T_{zz} &= -A \left(\frac{z}{R^3} + \frac{3z^3}{R^5} \right), \\ T_{rz} &= -A \left(\frac{r}{R^3} + \frac{3rz^2}{R^5} \right), & T_{r\theta} &= T_{z\theta} = 0, \end{aligned}$$

where $R^2 = r^2 + z^2$ and A is a constant related to the load. Verify that the given distribution of stress is in equilibrium in the absence of body forces.

Solution

From $R^2 = r^2 + z^2$, we obtain $\frac{\partial R}{\partial r} = \frac{r}{R}$, $\frac{\partial R}{\partial z} = \frac{z}{R}$.
Thus,

$$\frac{\partial T_{rr}}{\partial r} = A \left(-\frac{3z}{R^4} \frac{\partial R}{\partial r} - \frac{6rz}{R^5} + \frac{15r^2z}{R^6} \frac{\partial R}{\partial r} \right) = A \left(-\frac{3zr}{R^5} - \frac{6rz}{R^5} + \frac{15r^3z}{R^7} \right),$$

$$\frac{T_{rr} - T_{\theta\theta}}{r} = -A \left(\frac{3rz}{R^5} \right)$$

$$\frac{\partial T_{rz}}{\partial z} = -A \left(-\frac{3r}{R^4} \frac{\partial R}{\partial z} + \frac{6rz}{R^5} - \frac{15rz^2}{R^6} \frac{\partial R}{\partial z} \right) = A \left(\frac{3zr}{R^5} - \frac{6rz}{R^5} + \frac{15rz^3}{R^7} \right).$$

The left-hand side of Eq. (4.8.1) becomes

$$\begin{aligned} A \left(-\frac{3zr}{R^5} - \frac{6rz}{R^5} + \frac{15r^3z}{R^7} - \frac{3rz}{R^5} + \frac{3zr}{R^5} - \frac{6rz}{R^5} + \frac{15rz^3}{R^7} \right) &= A \left(-\frac{15rz}{R^5} + \frac{15rz}{R^7} \{r^2 + z^2\} \right) \\ &= A \left(-\frac{15rz}{R^5} + \frac{15rz}{R^5} \right) = 0. \end{aligned}$$

In other words, the r -equation of equilibrium is satisfied. Since $T_{r\theta} = T_{\theta z} = 0$ and $T_{\theta\theta}$ is independent of θ , the second equation of equilibrium is also satisfied. The third equation of equilibrium can be similarly verified (see Prob. 4.37).

4.9 BOUNDARY CONDITION FOR THE STRESS TENSOR

If on the boundary of some body there are applied distributive forces, we call them *surface tractions*. We wish to find the relation between the surface tractions and the stress field that is defined within the body.

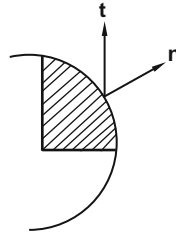

FIGURE 4.9-1

If we consider an infinitesimal tetrahedron cut from the boundary of a body with its inclined face coinciding with the plane tangent to the boundary face (Figure 4.9-1), then, as in Section 4.1, we obtain

$$\mathbf{t} = \mathbf{T}\mathbf{n}, \quad (4.9.1)$$

where \mathbf{n} is the unit outward normal vector to the boundary, \mathbf{T} is the stress tensor evaluated at the boundary, and \mathbf{t} is the force vector per unit area on the boundary. Equation (4.9.1) is called the *stress boundary condition*. The special case of $\mathbf{t} = 0$ is known as the *traction-free condition*.

Example 4.9.1

Given the following stress field in a thick-wall elastic cylinder:

$$T_{rr} = A + \frac{B}{r^2}, \quad T_{\theta\theta} = A - \frac{B}{r^2}, \quad T_{r\theta} = T_{rz} = T_{\theta z} = T_{zz} = 0,$$

where A and B are constants. (a) Verify that the given state of stress satisfies the equations of equilibrium in the absence of body forces. (b) Find the stress vector on a cylindrical surface $r = a$, and (c) if the surface traction on the inner surface $r = r_i$ is a uniform pressure p_i and the outer surface $r = r_o$ is free of surface traction, find the constant A and B .

Solution

- (a) With $T_{r\theta} = T_{rz} = T_{\theta z} = T_{zz} = 0$ and $T_{\theta\theta}$ depending only on r , we only need to check the r -equation of equilibrium. We have

$$\frac{\partial T_{rr}}{\partial r} + \frac{1}{r} \frac{\partial T_{r\theta}}{\partial \theta} + \frac{T_{rr} - T_{\theta\theta}}{r} + \frac{\partial T_{rz}}{\partial z} = -\frac{2B}{r^3} + 0 + \frac{2B}{r^3} + 0 = 0.$$

Thus, all equations of equilibrium are satisfied.

- (b) The unit outward normal vector to a cylindrical surface at $r = a$ is $\mathbf{n} = \mathbf{e}_r$. Thus, the stress vector on this surface is given by

$$\begin{bmatrix} t_r \\ t_\theta \\ t_z \end{bmatrix} = \begin{bmatrix} T_{rr} & 0 & 0 \\ 0 & T_{\theta\theta} & 0 \\ 0 & 0 & 0 \end{bmatrix} \begin{bmatrix} 1 \\ 0 \\ 0 \end{bmatrix} = \begin{bmatrix} T_{rr} \\ 0 \\ 0 \end{bmatrix},$$

i.e.,

$$\mathbf{t} = T_{rr}\mathbf{e}_r + 0\mathbf{e}_\theta + 0\mathbf{e}_z = \left(A + \frac{B}{a^2}\right)\mathbf{e}_r.$$

- (c) The boundary conditions are:

$$\text{At } r = r_o, \quad T_{rr} = 0 \quad \text{and} \quad \text{at } r = r_i, \quad T_{rr} = -p_i.$$

Thus,

$$A + \frac{B}{r_i^2} = -p_i \quad \text{and} \quad A + \frac{B}{r_o^2} = 0.$$

The preceding two equations give

$$A = \frac{\rho_i r_i^2}{r_o^2 - r_i^2}, \quad B = -\frac{\rho_i r_i^2 r_o^2}{r_o^2 - r_i^2},$$

and the state of stress is given by

$$T_{rr} = \frac{\rho_i r_i^2}{r_o^2 - r_i^2} \left(1 - \frac{r_o^2}{r^2}\right), \quad T_{\theta\theta} = \frac{\rho_i r_i^2}{r_o^2 - r_i^2} \left(1 + \frac{r_o^2}{r^2}\right).$$

Example 4.9.2

It is known that the equilibrium stress field in an elastic spherical shell under the action of external and internal pressure in the absence of body forces is of the form

$$T_{rr} = A - \frac{2B}{r^3}, \quad T_{\theta\theta} = T_{\phi\phi} = A + \frac{B}{r^3}, \quad T_{r\theta} = T_{r\phi} = T_{\theta\phi} = 0.$$

- Verify that the stress field satisfies the equations of equilibrium in the absence of body forces.
- Find the stress vector on a spherical surface $r = a$.
- Determine the constants A and B if the inner surface of the shell is subject to a uniform pressure p_i and the outer surface is free of surface traction.

Solution

(a) With

$$r^2 T_{rr} = Ar^2 - \frac{2B}{r}, \quad \frac{1}{r^2} \frac{\partial}{\partial r} (r^2 T_{rr}) = \frac{2A}{r} + \frac{2B}{r^4}, \quad T_{r\theta} = T_{r\phi} = 0 \quad \text{and} \quad \frac{T_{\theta\theta} + T_{\phi\phi}}{r} = \frac{2A}{r} + \frac{2B}{r^4},$$

the left-hand side of the r -equation of equilibrium [see Eq. (4.8.4)] is

$$\begin{aligned} & \frac{1}{r^2} \frac{\partial(r^2 T_{rr})}{\partial r} + \frac{1}{r \sin \theta} \frac{\partial(T_{r\theta} \sin \theta)}{\partial \theta} + \frac{1}{r \sin \theta} \frac{\partial T_{r\phi}}{\partial \phi} - \frac{T_{\theta\theta} + T_{\phi\phi}}{r} \\ &= \left(\frac{2A}{r} + \frac{2B}{r^4} \right) + 0 + 0 - \left(\frac{2A}{r} + \frac{2B}{r^4} \right) = 0, \end{aligned}$$

i.e., the r -equation of equilibrium is satisfied. The other two equations can be similarly verified (see Prob. 4.40).

- The unit outward normal vector to the spherical surface $r = a$ is $\mathbf{n} = \mathbf{e}_r$. Thus, the stress vector on this surface is given by

$$\begin{bmatrix} t_r \\ t_\theta \\ t_\phi \end{bmatrix} = \begin{bmatrix} T_{rr} & 0 & 0 \\ 0 & T_{\theta\theta} & 0 \\ 0 & 0 & T_{\phi\phi} \end{bmatrix} \begin{bmatrix} 1 \\ 0 \\ 0 \end{bmatrix} = \begin{bmatrix} T_{rr} \\ 0 \\ 0 \end{bmatrix},$$

i.e.,

$$\mathbf{t} = T_{rr} \mathbf{e}_r + 0 \mathbf{e}_\theta + 0 \mathbf{e}_\phi = \left(A - \frac{2B}{a^3} \right) \mathbf{e}_r.$$

(c) The boundary conditions are

$$\text{At } r = r_o, T_{rr} = 0 \quad \text{and} \quad \text{at } r = r_i, T_{rr} = -\rho_i.$$

Thus,

$$A - \frac{2B}{r_o^3} = 0 \quad \text{and} \quad A - \frac{2B}{r_i^3} = -\rho_i.$$

The preceding two equations give

$$A = \frac{\rho_i r_i^3}{(r_o^3 - r_i^3)} \quad \text{and} \quad B = \frac{\rho_i r_i^3 r_o^3}{2(r_o^3 - r_i^3)}.$$

The state of stress is

$$T_{rr} = \frac{\rho_i r_i^3}{(r_o^3 - r_i^3)} \left(1 - \frac{r_o^3}{r^3}\right), \quad T_{\theta\theta} = T_{\phi\phi} = \frac{\rho_i r_i^3}{(r_o^3 - r_i^3)} \left(1 + \frac{r_o^3}{2r^3}\right).$$

4.10 PIOLA KIRCHHOFF STRESS TENSORS

Cauchy stress tensor is defined in Section 4.2 based on the differential area at the current position. Stress tensors based on the undeformed area can also be defined. They are known as the *first* and *second Piola-Kirchhoff stress tensors*. It is useful to be familiar with them not only because they appear in many works on continuum mechanics but also because one particular tensor may be more suitable in a particular problem.

For example, there may be situations in which it is more convenient to formulate equations of motion (or equilibrium) with respect to the reference configuration instead of the current configuration. In this case, the use of the first Piola-Kirchhoff stress tensor results in the equations that are of the same form as the familiar Cauchy equations of motion (see Section 4.11). As another example, in finite deformations, depending on whether \mathbf{D} (the rate of deformation) or $D\mathbf{F}/Dt$ (\mathbf{F} being the deformation gradient) or $D\mathbf{E}^*/Dt$ (\mathbf{E}^* being Lagrangian deformation tensor) are used, the calculation of stress power (the rate at which work is done to change the volume and shape of a particle of unit volume) is most conveniently obtained using the Cauchy stress tensor, the first Piola-Kirchhoff stress tensor, or the second Piola-Kirchhoff stress tensor, respectively (see Section 4.13).

Also, in Example 5.57.3 of Chapter 5, we will see that $\mathbf{T} = \mathbf{f}(\mathbf{C})$, where \mathbf{T} is Cauchy's stress tensor and \mathbf{C} is the right Cauchy-Green deformation tensor, is not an acceptable form of constitutive equation. On the other hand, $\tilde{\mathbf{T}} = \mathbf{f}(\mathbf{C})$ is acceptable, where $\tilde{\mathbf{T}}$ is the second Piola-Kirchhoff stress tensor.

Let dA_o and dA be the same differential material area at the reference time t_o and the current time t , respectively. We may refer to dA_o as the undeformed area and dA as the deformed area. These two areas in general have different orientations. We let the unit normal to the undeformed area be \mathbf{n}_o and to the deformed area be \mathbf{n} . We may consider each area as a vector having a magnitude and a direction. For example, $dA_o = dA_o \mathbf{n}_o$ and $dA = dA \mathbf{n}$. Let $d\mathbf{f}$ be the force acting on the deformed area $dA = dA \mathbf{n}$. In Section 4.1, we defined the Cauchy stress vector \mathbf{t} and the associated Cauchy stress tensor \mathbf{T} based on the deformed area $dA = dA \mathbf{n}$, that is,

$$d\mathbf{f} = \mathbf{t}dA, \quad (4.10.1)$$

and

$$\mathbf{t} = \mathbf{T}\mathbf{n}. \quad (4.10.2)$$

In this section, we define two other pairs of (pseudo) stress vectors and tensors, based on the undeformed area $d\mathbf{A}_0 = dA_0\mathbf{n}_0$.

(A) *The first Piola-Kirchhoff stress tensor.* Let

$$d\mathbf{f} \equiv \mathbf{t}_0 dA_0. \quad (4.10.3)$$

The stress vector \mathbf{t}_0 , defined by the preceding equation, is a pseudo-stress vector in that, being based on the undeformed area, it does not describe the actual intensity of the force $d\mathbf{f}$, which acts on the deformed area $d\mathbf{A} = d\mathbf{A}\mathbf{n}$. We note that \mathbf{t}_0 has the same direction as the Cauchy stress vector \mathbf{t} .

The *first Piola-Kirchhoff stress tensor* (also known as the *Lagrangian stress tensor*) is a linear transformation \mathbf{T}_0 such that

$$\mathbf{t}_0 = \mathbf{T}_0\mathbf{n}_0. \quad (4.10.4)$$

The relation between the first Piola-Kirchhoff stress tensor and the Cauchy stress tensor can be obtained as follows: From

$$d\mathbf{f} = \mathbf{t}d\mathbf{A} = \mathbf{t}_0 dA_0, \quad (4.10.5)$$

we have

$$\mathbf{t}_0 = \left(\frac{d\mathbf{A}}{dA_0} \right) \mathbf{t}. \quad (4.10.6)$$

Using Eq. (4.10.2) and Eq. (4.10.4), Eq. (4.10.6) becomes

$$\mathbf{T}_0\mathbf{n}_0 = \left(\frac{d\mathbf{A}}{dA_0} \right) \mathbf{T}\mathbf{n} = \frac{\mathbf{T}(d\mathbf{A}\mathbf{n})}{dA_0}. \quad (4.10.7)$$

In Section 3.27, we obtained the relation between $d\mathbf{A}_0 = dA_0\mathbf{n}_0$ and $d\mathbf{A} = d\mathbf{A}\mathbf{n}$ as

$$d\mathbf{A}\mathbf{n} = dA_0 J (\mathbf{F}^{-1})^T \mathbf{n}_0. \quad (4.10.8)$$

where $J = |\det \mathbf{F}|$. Thus,

$$\mathbf{T}_0\mathbf{n}_0 = J \mathbf{T} (\mathbf{F}^{-1})^T \mathbf{n}_0. \quad (4.10.9)$$

The preceding equation is to be true for all \mathbf{n}_0 ; therefore,

$$\mathbf{T}_0 = J \mathbf{T} (\mathbf{F}^{-1})^T, \quad (4.10.10)$$

and

$$\mathbf{T} = \frac{1}{J} \mathbf{T}_0 \mathbf{F}^T. \quad (4.10.11)$$

These are the desired relationships. In Cartesian component form, we have

$$(T_0)_{ij} = J T_{im} F_{jm}^{-1}, \quad (4.10.12)$$

and

$$T_{ij} = \frac{1}{J} (T_0)_{im} F_{jm}. \quad (4.10.13)$$

When Cartesian coordinates are used for both the reference and the current configuration,

$$F_{im} = \frac{\partial x_i}{\partial X_m} \quad \text{and} \quad F_{im}^{-1} = \frac{\partial X_i}{\partial x_m}.$$

We note that the first Piola-Kirchhoff stress tensor is in general not symmetric.

(B) The *second Piola-Kirchhoff stress tensor*. Let

$$d\tilde{\mathbf{f}} = \tilde{\mathbf{t}} dA_0, \quad (4.10.14)$$

where

$$d\mathbf{f} = \mathbf{F} d\tilde{\mathbf{f}}. \quad (4.10.15)$$

In Eq. (4.10.15), $d\tilde{\mathbf{f}}$ is the (pseudo) differential force that transforms, under the deformation gradient \mathbf{F} , into the (actual) differential force $d\mathbf{f}$ at the deformed position; thus, the pseudo-vector $\tilde{\mathbf{f}}$ is in general in a different direction than that of the Cauchy stress vector \mathbf{t} .

The second Piola-Kirchhoff stress tensor is a linear transformation $\tilde{\mathbf{T}}$ such that

$$\tilde{\mathbf{t}} = \tilde{\mathbf{T}} \mathbf{n}_0, \quad (4.10.16)$$

where we recall that \mathbf{n}_0 is the unit normal to the undeformed area. From Eqs. (4.10.14), (4.10.15), and (4.10.16), we have

$$d\mathbf{f} = \mathbf{F} \tilde{\mathbf{T}} \mathbf{n}_0 dA_0. \quad (4.10.17)$$

We also have [see Eqs. (4.10.3) and (4.10.4)]

$$d\mathbf{f} \equiv \mathbf{t}_0 dA_0 = \mathbf{T}_0 \mathbf{n}_0 dA_0. \quad (4.10.18)$$

Comparing Eq. (4.10.17) with Eq. (4.10.18), we have

$$\tilde{\mathbf{T}} \mathbf{n}_0 = \mathbf{F}^{-1} \mathbf{T}_0 \mathbf{n}_0. \quad (4.10.19)$$

Again, this is to be valid for all \mathbf{n}_0 ; therefore,

$$\tilde{\mathbf{T}} = \mathbf{F}^{-1} \mathbf{T}_0. \quad (4.10.20)$$

Equation (4.10.20) gives the relationship between the first Piola-Kirchhoff stress tensor \mathbf{T}_0 and the second Piola-Kirchhoff stress tensor $\tilde{\mathbf{T}}$. The relationship between the second Piola-Kirchhoff stress tensor and the Cauchy stress tensor can be obtained from Eqs. (4.10.10) and (4.10.20). We have

$$\tilde{\mathbf{T}} = J \mathbf{F}^{-1} \mathbf{T} (\mathbf{F}^{-1})^T \quad \text{where} \quad J = |\det \mathbf{F}|. \quad (4.10.21)$$

We note that the second Piola-Kirchhoff stress tensor is a symmetric tensor if the Cauchy stress tensor is a symmetric one.

Example 4.10.1

The deformed configuration of a body is described by

$$x_1 = 4X_1, \quad x_2 = -\frac{1}{2}X_2, \quad x_3 = -\frac{1}{2}X_3. \quad (i)$$

If the Cauchy stress tensor for this body is

$$[\mathbf{T}] = \begin{bmatrix} 100 & 0 & 0 \\ 0 & 0 & 0 \\ 0 & 0 & 0 \end{bmatrix} \text{ MPa}. \quad (ii)$$

- (a) What is the corresponding first Piola-Kirchhoff stress tensor?
 (b) What is the corresponding second Piola-Kirchhoff stress tensor?

Solution

(a) From Eq. (i), we have

$$[\mathbf{F}] = \begin{bmatrix} 4 & 0 & 0 \\ 0 & -1/2 & 0 \\ 0 & 0 & -1/2 \end{bmatrix}, \quad [\mathbf{F}^{-1}] = \begin{bmatrix} 1/4 & 0 & 0 \\ 0 & -2 & 0 \\ 0 & 0 & -2 \end{bmatrix}, \quad \det \mathbf{F} = 1. \quad (iii)$$

Thus, the first Piola-Kirchhoff stress tensor is, from Eqs. (4.10.10), (ii), and (iii)

$$[\mathbf{T}_o] = (1)[\mathbf{T}][(\mathbf{F}^{-1})^T] = \begin{bmatrix} 100 & 0 & 0 \\ 0 & 0 & 0 \\ 0 & 0 & 0 \end{bmatrix} \begin{bmatrix} 1/4 & 0 & 0 \\ 0 & -2 & 0 \\ 0 & 0 & -2 \end{bmatrix} = \begin{bmatrix} 25 & 0 & 0 \\ 0 & 0 & 0 \\ 0 & 0 & 0 \end{bmatrix} \text{ MPa}. \quad (iv)$$

(b) From Eqs. (4.10.20) and (iv),

$$[\tilde{\mathbf{T}}] = [\mathbf{F}^{-1}] [\mathbf{T}_o] = \begin{bmatrix} 1/4 & 0 & 0 \\ 0 & -2 & 0 \\ 0 & 0 & -2 \end{bmatrix} \begin{bmatrix} 25 & 0 & 0 \\ 0 & 0 & 0 \\ 0 & 0 & 0 \end{bmatrix} = \begin{bmatrix} 25/4 & 0 & 0 \\ 0 & 0 & 0 \\ 0 & 0 & 0 \end{bmatrix} \text{ MPa}. \quad (v)$$

Example 4.10.2

The equilibrium configuration of a body is described by

$$x_1 = \frac{1}{2}X_1, \quad x_2 = -\frac{1}{2}X_3, \quad x_3 = 4X_2. \quad (i)$$

If the Cauchy stress tensor for this body is

$$[\mathbf{T}] = \begin{bmatrix} 0 & 0 & 0 \\ 0 & 0 & 0 \\ 0 & 0 & 100 \end{bmatrix} \text{ MPa}. \quad (ii)$$

- (a) What is the corresponding first Piola-Kirchhoff stress tensor?
 (b) What is the corresponding second Piola-Kirchhoff stress tensor?

- (c) Calculate the pseudo-stress vector associated with the first Piola-Kirchhoff stress tensor on the \mathbf{e}_3 -plane in the deformed state.
- (d) Calculate the pseudo-stress vector associated with the second Piola-Kirchhoff stress tensor on the \mathbf{e}_3 -plane in the deformed state.

Solution

From Eq. (i), we have

$$[\mathbf{F}] = \begin{bmatrix} 1/2 & 0 & 0 \\ 0 & 0 & -1/2 \\ 0 & 4 & 0 \end{bmatrix} \quad \text{and} \quad [\mathbf{F}^{-1}] = \begin{bmatrix} 2 & 0 & 0 \\ 0 & 0 & 1/4 \\ 0 & -2 & 0 \end{bmatrix}, \quad \det \mathbf{F} = 1. \quad (\text{iii})$$

- (a) The first Piola-Kirchhoff stress tensor is, from Eqs. (4.10.10), (ii), and (iii)

$$[\mathbf{T}_0] = (1)[\mathbf{T}] [(\mathbf{F}^{-1})^T] = \begin{bmatrix} 0 & 0 & 0 \\ 0 & 0 & 0 \\ 0 & 0 & 100 \end{bmatrix} \begin{bmatrix} 2 & 0 & 0 \\ 0 & 0 & -2 \\ 0 & 1/4 & 0 \end{bmatrix} = \begin{bmatrix} 0 & 0 & 0 \\ 0 & 0 & 0 \\ 0 & 25 & 0 \end{bmatrix} \text{ MPa}. \quad (\text{iv})$$

- (b) The second Piola-Kirchhoff stress tensor is, from Eqs. (4.10.20) and (iv),

$$[\tilde{\mathbf{T}}] = [\mathbf{F}^{-1}] [\mathbf{T}_0] = \begin{bmatrix} 2 & 0 & 0 \\ 0 & 0 & 1/4 \\ 0 & -2 & 0 \end{bmatrix} \begin{bmatrix} 0 & 0 & 0 \\ 0 & 0 & 0 \\ 0 & 25 & 0 \end{bmatrix} = \begin{bmatrix} 0 & 0 & 0 \\ 0 & 25/4 & 0 \\ 0 & 0 & 0 \end{bmatrix} \text{ MPa}. \quad (\text{v})$$

- (c) For a unit area in the deformed state in the \mathbf{e}_3 direction, its undeformed area $dA_0 \mathbf{n}_0$ is given by [see Eq. (3.27.12)]:

$$dA_0 \mathbf{n}_0 = \frac{1}{|\det \mathbf{F}|} \mathbf{F}^T \mathbf{n}. \quad (\text{vi})$$

Using Eq. (iii) in Eq. (vi), we have, with $\mathbf{n} = \mathbf{e}_3$,

$$[dA_0 \mathbf{n}_0] = \begin{bmatrix} 1/2 & 0 & 0 \\ 0 & 0 & 4 \\ 0 & -1/2 & 0 \end{bmatrix} \begin{bmatrix} 0 \\ 0 \\ 1 \end{bmatrix} = \begin{bmatrix} 0 \\ 4 \\ 0 \end{bmatrix}. \quad (\text{vii})$$

That is,

$$\mathbf{n}_0 = \mathbf{e}_2 \quad \text{and} \quad dA_0 = 4. \quad (\text{viii})$$

Thus, the stress vector associated with the first Piola-Kirchhoff stress tensor is

$$[\mathbf{t}_0] = [\mathbf{T}_0] [\mathbf{n}_0] = \begin{bmatrix} 0 & 0 & 0 \\ 0 & 0 & 0 \\ 0 & 25 & 0 \end{bmatrix} \begin{bmatrix} 0 \\ 1 \\ 0 \end{bmatrix} = \begin{bmatrix} 0 \\ 0 \\ 25 \end{bmatrix} \text{ MPa}. \quad (\text{ix})$$

That is, $\mathbf{t}_0 = 25\mathbf{e}_3$ MPa. We note that this vector is in the same direction as the Cauchy stress vector; its magnitude is one fourth of that of the Cauchy stress vector because the undeformed area is four times that of the deformed area.

- (d) The stress vector associated with the second Piola-Kirchhoff stress tensor is

$$[\tilde{\mathbf{t}}] = [\tilde{\mathbf{T}}] [\mathbf{n}_0] = \begin{bmatrix} 0 & 0 & 0 \\ 0 & 25/4 & 0 \\ 0 & 0 & 0 \end{bmatrix} \begin{bmatrix} 0 \\ 1 \\ 0 \end{bmatrix} = \begin{bmatrix} 0 \\ 25/4 \\ 0 \end{bmatrix} \text{ MPa}. \quad (\text{x})$$

That is, $\tilde{\mathbf{t}} = (25/4)\mathbf{e}_2$ MPa. We see that this pseudo-stress vector is in a different direction from that of the Cauchy stress vector.

Example 4.10.3

Given the following identity for any tensor function $\mathbf{A}(X_1, X_2, X_3)$ (see Prob. 3.73):

$$\frac{\partial}{\partial X_m} \det \mathbf{A} = (\det \mathbf{A})(\mathbf{A}^{-1})_{nj} \frac{\partial A_{jn}}{\partial X_m}. \quad (4.10.22)$$

Show that for the deformation gradient tensor \mathbf{F}

$$\frac{\partial}{\partial x_j} \left(\frac{F_{jm}}{J} \right) = 0, \quad (4.10.23)$$

where $F_{jm} = \frac{\partial x_j}{\partial X_m}$, $x_j = \hat{x}_j(X_1, X_2, X_3, t)$, $J = \det \mathbf{F} > 0$.

Solution

$$\begin{aligned} \frac{\partial}{\partial x_j} \left(\frac{F_{jm}}{J} \right) &= \frac{1}{J} \frac{\partial F_{jm}}{\partial x_j} - \frac{F_{jm}}{J^2} \frac{\partial J}{\partial x_j} = \frac{1}{J} \frac{\partial F_{jm}}{\partial X_n} \frac{\partial X_n}{\partial x_j} - \frac{1}{J^2} \left(\frac{\partial x_j}{\partial X_m} \right) \frac{\partial J}{\partial X_n} \frac{\partial X_n}{\partial x_j} \\ &= \frac{1}{J} \frac{\partial F_{jm}}{\partial X_n} \frac{\partial X_n}{\partial x_j} - \frac{1}{J^2} \delta_{nm} \frac{\partial J}{\partial X_n} = \frac{1}{J} \left(\frac{\partial^2 x_j}{\partial X_n \partial X_m} \right) \frac{\partial X_n}{\partial x_j} - \frac{1}{J^2} \frac{\partial J}{\partial X_m}. \end{aligned} \quad (i)$$

Now, from the given identity Eq. (4.10.22), with $\mathbf{A} \equiv \mathbf{F}$, $(\mathbf{A}^{-1})_{nj} = (\mathbf{F}^{-1})_{nj} = \frac{\partial X_n}{\partial x_j}$, we have

$$\frac{\partial J}{\partial X_m} = J \frac{\partial X_n}{\partial x_j} \frac{\partial F_{jn}}{\partial X_m} = J \frac{\partial X_n}{\partial x_j} \frac{\partial^2 x_j}{\partial X_m \partial X_n}. \quad (ii)$$

Thus,

$$\frac{\partial}{\partial x_j} \left(\frac{F_{jm}}{J} \right) = \frac{1}{J} \left(\frac{\partial^2 x_j}{\partial X_n \partial X_m} \right) \frac{\partial X_n}{\partial x_j} - \frac{1}{J} \frac{\partial X_n}{\partial x_j} \left(\frac{\partial^2 x_j}{\partial X_m \partial X_n} \right) = 0. \quad (iii)$$

4.11 EQUATIONS OF MOTION WRITTEN WITH RESPECT TO THE REFERENCE CONFIGURATION

In Section 4.7, we derive the equations of motion in terms of the Cauchy stress tensor as follows:

$$\operatorname{div} \mathbf{T} + \rho \mathbf{B} = \rho \mathbf{a} \quad \text{or} \quad \frac{\partial T_{ij}}{\partial x_j} + \rho B_i = \rho a_i, \quad (4.11.1)$$

where \mathbf{T} is the Cauchy stress tensor, \mathbf{B} is the body force per unit mass, \mathbf{a} is the acceleration, and ρ is the density in the deformed state. Here the partial derivative $\partial T_{ij}/\partial x_j$ is with respect to the spatial coordinates x_j .

In this section we show that the equations of motion written in terms of the first Piola-Kirchhoff stress tensor have the same form as those written in terms of Cauchy stress tensor. That is,

$$\operatorname{Div} \mathbf{T}_o + \rho_o \mathbf{B} = \rho_o \mathbf{a} \quad \text{or} \quad \frac{\partial (T_o)_{im}}{\partial X_m} + \rho_o B_i = \rho_o a_i. \quad (4.11.2)$$

We note, however, here X_j are the material coordinates and ρ_o is the density at the reference state.

To derive Eq. (4.11.2), we use Eq. (4.10.13), i.e.,

$$T_{ij} = \frac{1}{J} (T_o)_{im} F_{jm} \quad \text{where } J = \det \mathbf{F}, \quad (\text{i})$$

to obtain

$$\frac{\partial T_{ij}}{\partial x_j} = \frac{\partial}{\partial x_j} \frac{(T_o)_{im} F_{jm}}{J} = \frac{F_{jm}}{J} \frac{\partial (T_o)_{im}}{\partial x_j} + (T_o)_{im} \frac{\partial F_{jm}}{\partial x_j} \frac{1}{J} = \frac{F_{jm}}{J} \frac{\partial (T_o)_{im}}{\partial x_j}, \quad (\text{ii})$$

where we have used the result of the previous example (Example 4.10.3) that $\frac{\partial}{\partial x_j} \frac{F_{jm}}{J} = 0$. Now,

$$\frac{\partial T_{ij}}{\partial x_j} = \frac{F_{jm}}{J} \frac{\partial (T_o)_{im}}{\partial x_j} = \frac{1}{J} \frac{\partial x_j}{\partial X_m} \frac{\partial (T_o)_{im}}{\partial X_n} \frac{\partial X_n}{\partial x_j} = \frac{1}{J} \delta_{mn} \frac{\partial (T_o)_{im}}{\partial X_n}. \quad (\text{iii})$$

Thus,

$$\frac{\partial T_{ij}}{\partial x_j} = \frac{1}{J} \frac{\partial (T_o)_{ij}}{\partial X_j}. \quad (\text{iv})$$

Using the preceding equation in the Cauchy equations of motion, i.e., $\frac{\partial T_{ij}}{\partial x_j} + \rho B_i = \rho a_i$, we obtain

$$\frac{\partial (T_o)_{ij}}{\partial X_j} + (J\rho) B_i = (J\rho) a_i. \quad (\text{v})$$

Now, $dV = (\det \mathbf{F}) dV_o$ [see Eq. (3.28.3)]; therefore,

$$\rho_o = (\det \mathbf{F}) \rho = J\rho, \quad (\text{vi})$$

and Eq. (v) becomes

$$\frac{\partial (T_o)_{ij}}{\partial X_j} + \rho_o B_i = \rho_o a_i. \quad (\text{vii})$$

4.12 STRESS POWER

Referring to the infinitesimal rectangular parallelepiped of Figure 4.12-1 (which is the same as Figure 4.7-1, repeated here for convenience), the rate at which work is done by the stress vectors $\mathbf{t}_{-\mathbf{e}_1}$ and $\mathbf{t}_{\mathbf{e}_1}$ on the pair of faces having $-\mathbf{e}_1$ and \mathbf{e}_1 as their respective normal is

$$\begin{aligned} \left[(\mathbf{t}_{\mathbf{e}_1} \cdot \mathbf{v})_{x_1+dX_1, x_2, x_3} + (\mathbf{t}_{-\mathbf{e}_1} \cdot \mathbf{v})_{x_1, x_2, x_3} \right] dx_2 dx_3 &= \left[(\mathbf{t}_{\mathbf{e}_1} \cdot \mathbf{v})_{x_1+dX_1, x_2, x_3} - (\mathbf{t}_{\mathbf{e}_1} \cdot \mathbf{v})_{x_1, x_2, x_3} \right] dx_2 dx_3 \\ &= \left[\frac{\partial}{\partial x_1} (\mathbf{t}_{\mathbf{e}_1} \cdot \mathbf{v}) dx_1 \right] dx_2 dx_3 = \frac{\partial (T_{j1} v_j)}{\partial x_1} dV, \end{aligned} \quad (\text{i})$$

where we have used the result that $\mathbf{t}_{\mathbf{e}_1} \cdot \mathbf{v} = \mathbf{T} \mathbf{e}_1 \cdot \mathbf{v} = \mathbf{e}_1 \cdot \mathbf{T}^T \mathbf{v} = \mathbf{e}_1 \cdot T_{ji} v_j \mathbf{e}_i = T_{ji} v_j (\mathbf{e}_1 \cdot \mathbf{e}_i) = T_{j1} v_j$ and $dx_1 dx_2 dx_3 = dV$. Similarly, the rate at which work is done by the stress vectors on the other two pairs of faces are $\frac{\partial (T_{2j} v_j)}{\partial x_2} dV$ and $\frac{\partial (T_{3j} v_j)}{\partial x_3} dV$. Including the rate of work done by the body forces, which is $(\rho \mathbf{B} dV) \cdot \mathbf{v} = \rho B_i v_i dV$, the total rate of work done on the particle is

$$P = \left[\frac{\partial}{\partial x_j} (v_i T_{ij}) + \rho B_i v_i \right] dV = \left[v_i \left(\frac{\partial T_{ij}}{\partial x_j} + \rho B_i \right) + T_{ij} \frac{\partial v_i}{\partial x_j} \right] dV = \left[\rho v_i \frac{Dv_i}{Dt} + T_{ij} \frac{\partial v_i}{\partial x_j} \right] dV. \quad (\text{ii})$$

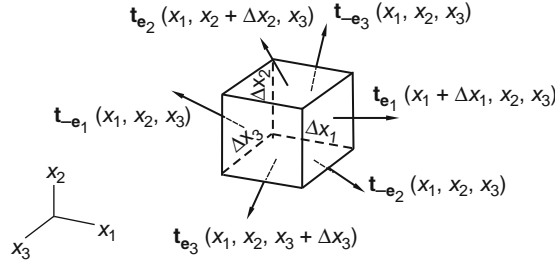

FIGURE 4.12-1

Now, $\frac{D}{Dt}(\rho dV) = 0$ (conservation of mass principle); therefore,

$$\rho v_i \frac{Dv_i}{Dt} dV = \rho dV \frac{D}{Dt} \left(\frac{v_i v_i}{2} \right) = \frac{D}{Dt} \left(\frac{v_i v_i}{2} \rho dV \right) = \frac{D}{Dt} \left(dm \frac{v^2}{2} \right) = \frac{D}{Dt} (KE). \quad (\text{iii})$$

where (KE) is the kinetic energy. We can now write

$$P = \frac{D}{Dt} (KE) + P_s dV, \quad (4.12.1)$$

where

$$P_s = T_{ij} \frac{\partial v_i}{\partial x_j} = \text{tr}(\mathbf{T}^T \nabla \mathbf{v}). \quad (4.12.2)$$

Since

$$T_{ij} \frac{\partial v_i}{\partial x_j} = \frac{1}{2} \left(T_{ij} \frac{\partial v_i}{\partial x_j} + T_{ij} \frac{\partial v_i}{\partial x_j} \right) = \frac{1}{2} \left(T_{ij} \frac{\partial v_i}{\partial x_j} + T_{ji} \frac{\partial v_j}{\partial x_i} \right) = \frac{1}{2} T_{ij} \left(\frac{\partial v_i}{\partial x_j} + \frac{\partial v_j}{\partial x_i} \right) = T_{ij} D_{ij}, \quad (4.12.3)$$

in terms of the symmetric stress tensor \mathbf{T} and the rate of deformation tensor \mathbf{D} , the stress power is

$$P_s = T_{ij} D_{ij} = \text{tr}(\mathbf{T}\mathbf{D}). \quad (4.12.4)$$

The *stress power* P_s represents the rate at which work is done to change the volume and shape of a particle of unit volume.

4.13 STRESS POWER IN TERMS OF THE PIOLA-KIRCHHOFF STRESS TENSORS

In the previous section, we obtained the stress power in terms of the Cauchy stress tensor \mathbf{T} and the rate of deformation tensor \mathbf{D} [Eq. (4.12.4)]. In this section we obtain the stress power (a) in terms of the first Piola-Kirchhoff stress tensor \mathbf{T}_o and the deformation gradient \mathbf{F} and (b) in terms of the second Piola-Kirchhoff stress tensor $\hat{\mathbf{T}}$ and the Lagrangian deformation tensor \mathbf{E}^* . The pairs (\mathbf{T}, \mathbf{D}) , $(\mathbf{T}_o, \mathbf{F})$ and $(\hat{\mathbf{T}}, \mathbf{E}^*)$ are sometimes known as the *conjugate pairs*.

(a) In Section 3.12 we obtained [see Eq. (3.12.6)]

$$\frac{D}{Dt}d\mathbf{x} = (\nabla_{\mathbf{x}}\mathbf{v})d\mathbf{x}. \quad (4.13.1)$$

Since $d\mathbf{x} = \mathbf{F}d\mathbf{X}$ [see Eq. (3.18.3)], Eq. (4.13.1) becomes

$$\frac{D}{Dt}\mathbf{F}d\mathbf{X} = \frac{D\mathbf{F}}{Dt}d\mathbf{X} = \nabla_{\mathbf{x}}\mathbf{v}\mathbf{F}d\mathbf{X}. \quad (4.13.2)$$

This equation is to be true for all $d\mathbf{X}$, thus

$$\frac{D\mathbf{F}}{Dt} = (\nabla_{\mathbf{x}}\mathbf{v})\mathbf{F}, \quad (4.13.3)$$

or

$$(\nabla_{\mathbf{x}}\mathbf{v}) = \frac{D\mathbf{F}}{Dt}\mathbf{F}^{-1}. \quad (4.13.4)$$

Now, from Eqs. (4.12.2) and (4.13.4), we have

$$P_s = \text{tr}\left(\mathbf{T}^T \frac{D\mathbf{F}}{Dt} \mathbf{F}^{-1}\right). \quad (4.13.5)$$

Since the Cauchy stress tensor \mathbf{T} is related to the first Piola-Kirchhoff stress tensor \mathbf{T}_o by the equation

$$\mathbf{T} = \frac{1}{\det \mathbf{F}} \mathbf{T}_o \mathbf{F}^T, \quad [\text{Eq. (4.10.11)}], \text{ therefore,}$$

$$P_s = \frac{1}{\det \mathbf{F}} \text{tr}\left(\mathbf{F} \mathbf{T}_o^T \frac{D\mathbf{F}}{Dt} \mathbf{F}^{-1}\right). \quad (4.13.6)$$

Using the identity $\text{tr}(\mathbf{ABCD}) = \text{tr}(\mathbf{BCDA}) = \text{tr}(\mathbf{CDAB})$ and the relation $\det \mathbf{F} = \rho_o/\rho$, we have

$$P_s = \frac{\rho}{\rho_o} \text{tr}\left(\mathbf{T}_o^T \frac{D\mathbf{F}}{Dt}\right) = \frac{\rho}{\rho_o} \text{tr}\left((T_o)_{ij} \frac{DF_{ij}}{Dt}\right). \quad (4.13.7)$$

(b) The Cauchy stress tensor \mathbf{T} is related to the second Piola-Kirchhoff stress tensor $\tilde{\mathbf{T}}$ by the equation

$$\mathbf{T} = \frac{1}{\det \mathbf{F}} \mathbf{F} \tilde{\mathbf{T}} \mathbf{F}^T \quad [\text{see Eq. (4.10.21)}], \text{ therefore,}$$

$$P_s = \text{tr}(\mathbf{T}\mathbf{D}) = \frac{1}{\det \mathbf{F}} \text{tr}(\mathbf{F} \tilde{\mathbf{T}} \mathbf{F}^T \mathbf{D}) = \frac{1}{\det \mathbf{F}} \text{tr}(\tilde{\mathbf{T}} \mathbf{F}^T \mathbf{D} \mathbf{F}). \quad (4.13.8)$$

We now show that

$$\left(\frac{D\mathbf{E}^*}{Dt}\right) = \mathbf{F}^T \mathbf{D} \mathbf{F}. \quad (4.13.9)$$

We had [see Eq. (3.24.3)]

$$ds^2 = dS^2 + 2d\mathbf{X} \cdot \mathbf{E}^* d\mathbf{X}, \quad (4.13.10)$$

therefore,

$$\frac{D}{Dt}ds^2 = 2d\mathbf{X} \cdot \left(\frac{D\mathbf{E}^*}{Dt}\right)d\mathbf{X}. \quad (4.13.11)$$

But we also had [see Eq. (3.13.11)]

$$\frac{D}{Dt} ds^2 = 2d\mathbf{x} \cdot \mathbf{D}d\mathbf{x} = 2\mathbf{F}d\mathbf{X} \cdot \mathbf{D}\mathbf{F}d\mathbf{X} = 2d\mathbf{X} \cdot \mathbf{F}^T \mathbf{D}\mathbf{F}d\mathbf{X}. \quad (4.13.12)$$

Comparing Eq. (4.13.11) with Eq. (4.13.12), we obtain

$$\left(\frac{D\mathbf{E}^*}{Dt} \right) = \mathbf{F}^T \mathbf{D}\mathbf{F}. \quad (4.13.13)$$

Using Eq. (4.13.13), Eq. (4.13.8) becomes

$$P_s = \frac{1}{\det \mathbf{F}} \operatorname{tr} \left(\tilde{\mathbf{T}} \frac{D\mathbf{E}^*}{Dt} \right) = \frac{\rho}{\rho_0} \operatorname{tr} \left(\tilde{\mathbf{T}} \frac{D\mathbf{E}^*}{Dt} \right). \quad (4.13.14)$$

4.14 RATE OF HEAT FLOW INTO A DIFFERENTIAL ELEMENT BY CONDUCTION

Let \mathbf{q} be a vector whose magnitude gives the rate of heat flow across a unit area by conduction and whose direction gives the direction of the heat flow; then the net heat flow by conduction Q_c into a differential element can be computed as follows:

Referring to the infinitesimal rectangular parallelepiped of Figure 4.12-1, the net rate at which heat flows *into* the element across the pair of faces with \mathbf{e}_1 and $-\mathbf{e}_1$ as their outward normal vectors is

$$\left[-(\mathbf{q} \cdot \mathbf{e}_1)_{x_1+dx_1, x_2, x_3} + (\mathbf{q} \cdot \mathbf{e}_1)_{x_1, x_2, x_3} \right] dx_2 dx_3 = - \left[\frac{\partial}{\partial x_1} (\mathbf{q} \cdot \mathbf{e}_1) dx_1 \right] dx_2 dx_3 = - \left(\frac{\partial q_1}{\partial x_1} dx_1 \right) dx_2 dx_3. \quad (i)$$

Including the contributions from the other two pairs of faces, the total net rate of heat *inflow* by conduction into the element is

$$- \left(\frac{\partial q_1}{\partial x_1} dx_1 \right) dx_2 dx_3 - \left(\frac{\partial q_2}{\partial x_2} dx_2 \right) dx_1 dx_3 - \left(\frac{\partial q_3}{\partial x_3} dx_3 \right) dx_1 dx_2 = - \left(\frac{\partial q_1}{\partial x_1} + \frac{\partial q_2}{\partial x_2} + \frac{\partial q_3}{\partial x_3} \right) dx_1 dx_2 dx_3. \quad (ii)$$

That is,

$$Q_c = - \left(\frac{\partial q_1}{\partial x_1} + \frac{\partial q_2}{\partial x_2} + \frac{\partial q_3}{\partial x_3} \right) dV = -(\operatorname{div} \mathbf{q}) dV, \quad (4.14.1)$$

where dV is the differential volume of the element.

Example 4.14.1

Using the Fourier heat conduction law

$$\mathbf{q} = -\kappa \nabla \Theta, \quad (4.14.2)$$

where Θ is the temperature and κ is the coefficient of thermal conductivity, find the equation governing the steady-state temperature distribution in a heat-conducting body.

Solution

Using Eq. (4.14.1), we obtain, the net rate of heat inflow per unit volume at a point in the body as

$$-\left[\frac{\partial}{\partial x_1} \left(\kappa \frac{\partial \Theta}{\partial x_1} \right) + \frac{\partial}{\partial x_2} \left(\kappa \frac{\partial \Theta}{\partial x_2} \right) + \frac{\partial}{\partial x_3} \left(\kappa \frac{\partial \Theta}{\partial x_3} \right) \right]$$

For a steady-state temperature distribution in the body, there should be no net rate of heat flow (either in or out) at every point in the body. Therefore, the governing equation is

$$\frac{\partial}{\partial x_1} \left(\kappa \frac{\partial \Theta}{\partial x_1} \right) + \frac{\partial}{\partial x_2} \left(\kappa \frac{\partial \Theta}{\partial x_2} \right) + \frac{\partial}{\partial x_3} \left(\kappa \frac{\partial \Theta}{\partial x_3} \right) = 0. \quad (4.14.3)$$

For constant κ , the preceding equation reduces to the Laplace equation:

$$\nabla^2 \Theta = \frac{\partial^2 \Theta}{\partial x_1^2} + \frac{\partial^2 \Theta}{\partial x_2^2} + \frac{\partial^2 \Theta}{\partial x_3^2} = 0. \quad (4.14.4)$$

4.15 ENERGY EQUATION

Consider a particle with a differential volume dV at position \mathbf{x} at time t . Let U denote its internal energy, KE its kinetic energy, Q_c the net rate of heat inflow by conduction from its surroundings, Q_s the heat supply (rate of heat input due, e.g., to radiation), and P the rate of work done on the particle by body forces and surface forces. Then, in the absence of other forms of energy input, the fundamental postulate of conservation of energy states that *the rate of increase of internal and kinetic energy for a particle equals the work done on the material plus heat input through conduction across its boundary surface and heat supply throughout its volume*. That is,

$$\frac{D}{Dt}(U + KE) = P + Q_c + Q_s, \quad (4.15.1)$$

where (D/Dt) is material derivative, $P = \frac{D}{Dt}(KE) + T_{ij} \frac{\partial v_i}{\partial x_j} dV$ and $Q_c = -\frac{\partial q_i}{\partial x_i} dV$. [See Eqs. (4.12.1), (4.12.2), and (4.14.1)]. Thus,

$$\frac{DU}{Dt} = T_{ij} \frac{\partial v_i}{\partial x_j} dV - \frac{\partial q_i}{\partial x_i} dV + Q_s. \quad (4.15.2)$$

If we let u be the internal energy per unit mass, then

$$\frac{DU}{Dt} = \frac{D}{Dt}(u \rho dV) = \rho dV \frac{Du}{Dt}, \quad (4.15.3)$$

where we have used the conservation of mass equation $\frac{D}{Dt}(\rho dV) = 0$. The energy equation then becomes

$$\rho \frac{Du}{Dt} = T_{ij} \frac{\partial v_i}{\partial x_j} - \frac{\partial q_i}{\partial x_i} + \rho q_s, \quad (4.15.4)$$

where q_s is heat supply per unit mass. In direct notation, the preceding equation reads

$$\rho \frac{Du}{Dt} = \text{tr}(\mathbf{TD}) - \text{div} \mathbf{q} + \rho q_s. \quad (4.15.5)$$

4.16 ENTROPY INEQUALITY

Let $\eta(\mathbf{x}, t)$ denote the entropy per unit mass for the continuum. Then the entropy in a particle of volume dV is $\rho\eta dV$, where ρ is density. The rate of increase of entropy following the particle as it is moving is

$$\frac{D}{Dt}(\rho\eta dV) = \rho dV \frac{D\eta}{Dt} + \eta \frac{D}{Dt}(\rho dV) = \rho dV \frac{D\eta}{Dt}, \quad (4.16.1)$$

where we have used the equation $(D/Dt)(\rho dV) = 0$ in accordance with the conservation of mass principle. Thus, per unit volume, the rate of increase of entropy is given by $\rho(D\eta/Dt)$. The entropy inequality law states that *the rate of increase of entropy in a particle is always greater than or equal to the entropy inflow across its boundary surface plus entropy supply throughout the volume*. That is,

$$\rho \frac{D\eta}{Dt} \geq -\operatorname{div} \left(\frac{\mathbf{q}}{\Theta} \right) + \frac{\rho q_s}{\Theta}, \quad (4.16.2)$$

where Θ is absolute temperature, \mathbf{q} is heat flux vector, and q_s is heat supply.

Example 4.16.1

The temperature at $x_1 = 0$ of a body is kept at a constant Θ_1 and that at $x_1 = L$ is kept at a constant Θ_2 . (a) Using the Fourier heat conduction law $\mathbf{q} = -\kappa \nabla \Theta$, where κ is a constant, find the temperature distribution. (b) Show that κ must be positive in order to satisfy the entropy inequality law.

Solution

- (a) This is a one-dimensional steady-state temperature problem. The equation governing the temperature distribution is given by [see Eq. (4.14.4)]:

$$\frac{d^2 \Theta}{dx_1^2} = 0. \quad (4.16.3)$$

Thus,

$$\Theta = \frac{\Theta_2 - \Theta_1}{L} x_1 + \Theta_1. \quad (4.16.4)$$

- (b) With $\frac{D\eta}{Dt} = 0$ and $q_s = 0$, the inequality [Eq. (4.16.2)] becomes

$$0 \geq -\frac{d}{dx_1} \left[\frac{1}{\Theta} \left(-\kappa \frac{d\Theta}{dx_1} \right) \right] = \kappa \frac{d}{dx_1} \left[\frac{1}{\Theta} \left(\frac{d\Theta}{dx_1} \right) \right]. \quad (4.16.5)$$

Now,

$$\kappa \frac{d}{dx_1} \left[\frac{1}{\Theta} \left(\frac{d\Theta}{dx_1} \right) \right] = \kappa \left[\frac{1}{\Theta} \left(\frac{d^2 \Theta}{dx_1^2} \right) - \frac{1}{\Theta^2} \left(\frac{d\Theta}{dx_1} \right)^2 \right] = -\kappa \frac{1}{\Theta^2} \left(\frac{\partial \Theta}{\partial x_1} \right)^2.$$

Therefore, we have

$$\kappa \frac{1}{\Theta^2} \left(\frac{\partial \Theta}{\partial x_1} \right)^2 \geq 0. \quad (4.16.6)$$

Thus,

$$\kappa \geq 0, \quad (4.16.7)$$

and heat flows from high temperature to low temperature.

4.17 ENTROPY INEQUALITY IN TERMS OF THE HELMHOLTZ ENERGY FUNCTION

The Helmholtz energy per unit mass A is defined by the equation

$$A = u - \Theta\eta, \quad (4.17.1)$$

where u and η are internal energy per unit mass and entropy per unit mass, respectively, and Θ is absolute temperature. From Eq. (4.17.1), $u = A + \Theta\eta$, so that the energy equation, [Eq. (4.15.4)], i.e.,

$\rho \frac{Du}{Dt} = T_{ij} \frac{\partial v_i}{\partial x_j} - \frac{\partial q_i}{\partial x_i} + \rho q_s$, can be written as

$$\rho\Theta \frac{D\eta}{Dt} = -\left(\rho \frac{DA}{Dt} + \rho\eta \frac{D\Theta}{Dt}\right) + T_{ij} \frac{\partial v_i}{\partial x_j} - \frac{\partial q_i}{\partial x_i} + \rho q_s, \quad (4.17.2)$$

and the entropy inequality, [Eq. (4.16.2)], i.e., $\rho \frac{D\eta}{Dt} \geq -\text{div} \left(\frac{\mathbf{q}}{\Theta} \right) + \frac{\rho q_s}{\Theta}$, can be written as

$$\rho\Theta \frac{D\eta}{Dt} \geq -\Theta \frac{\partial}{\partial x_i} \left(\frac{q_i}{\Theta} \right) + \rho q_s. \quad (4.17.3)$$

Using Eq. (4.17.2), the inequality Eq. (4.17.3) becomes

$$-\left(\rho \frac{DA}{Dt} + \rho\eta \frac{D\Theta}{Dt}\right) + T_{ij} \frac{\partial v_i}{\partial x_j} - \frac{\partial q_i}{\partial x_i} + \rho q_s \geq -\frac{\partial q_i}{\partial x_i} + \frac{q_i}{\Theta} \frac{\partial \Theta}{\partial x_i} + \rho q_s.$$

That is,

$$-\left(\rho \frac{DA}{Dt} + \rho\eta \frac{D\Theta}{Dt}\right) + T_{ij} D_{ij} - \frac{q_i}{\Theta} \frac{\partial \Theta}{\partial x_i} \geq 0, \quad (4.17.4)$$

where D_{ij} are components of the rate of deformation tensor and we have used the equation $T_{ij} \frac{\partial v_i}{\partial x_j} = T_{ij} D_{ij}$ for symmetric tensor T_{ij} . Equation (4.17.4) is the entropy law in terms of the Helmholtz energy function.

Example 4.17.1

In linear thermo-elasticity, one assumes that the Helmholtz function depends on the infinitesimal strain E_{ij} and absolute temperature Θ . That is,

$$A = A(\bar{E}_{ij}, \Theta). \quad (4.17.5)$$

Derive the relationship between the stress tensor and the Helmholtz energy function.

Solution

From Eq. (4.17.5), we have

$$\frac{DA}{Dt} = \frac{\partial A}{\partial E_{ij}} \frac{DE_{ij}}{Dt} + \frac{\partial A}{\partial \Theta} \frac{D\Theta}{Dt}. \quad (4.17.6)$$

For small strain, $\frac{DE_{ij}}{Dt} = \frac{1}{2} \frac{D}{Dt} \left(\frac{\partial u_i}{\partial X_j} + \frac{\partial u_j}{\partial X_i} \right) = \frac{1}{2} \left(\frac{\partial v_i}{\partial X_j} + \frac{\partial v_j}{\partial X_i} \right) \approx \frac{1}{2} \left(\frac{\partial v_i}{\partial x_j} + \frac{\partial v_j}{\partial x_i} \right) = D_{ij}$.

Thus, $\frac{DA}{Dt} = D_{ij} \frac{\partial A}{\partial E_{ij}} + \frac{\partial A}{\partial \Theta} \frac{D\Theta}{Dt}$, and the inequality (4.17.4) becomes

$$\left(-\rho \frac{\partial A}{\partial E_{ij}} + T_{ij}\right) D_{ij} - \left(\rho \frac{\partial A}{\partial \Theta} + \rho \eta\right) \frac{D\Theta}{Dt} - \frac{q_i}{\Theta} \frac{\partial \Theta}{\partial x_i} \geq 0. \quad (4.17.7)$$

This inequality must be satisfied for whatever values of D_{ij} and $\frac{D\Theta}{Dt}$. It follows that

$$\left(-\rho \frac{\partial A}{\partial E_{ij}} + T_{ij}\right) = 0, \quad \left(\rho \frac{\partial A}{\partial \Theta} + \rho \eta\right) = 0 \quad \text{and} \quad -\frac{q_i}{\Theta} \frac{\partial \Theta}{\partial x_i} \geq 0. \quad (4.17.8)$$

That is,

$$T_{ij} = \rho \frac{\partial A}{\partial E_{ij}}, \quad (4.17.9)$$

$$\eta = -\frac{\partial A}{\partial \Theta}, \quad (4.17.10)$$

and

$$-\frac{q_i}{\Theta} \frac{\partial \Theta}{\partial x_i} \geq 0. \quad (4.17.11)$$

The first equation states that the stress is derivable from a potential function; the last inequality states that heat must flow from high temperature to low temperature.

4.18 INTEGRAL FORMULATIONS OF THE GENERAL PRINCIPLES OF MECHANICS

In Section 3.15 of Chapter 3 and in Sections 4.4, 4.7, 4.15, and 4.16 of the current chapter, the field equations expressing the principles of conservation of mass, moment of momentum, linear momentum, energy, and the entropy inequality were derived using a differential element approach, and each of them was derived whenever the relevant tensors (e.g., the rate of deformation tensor, the Cauchy stress tensors, and so on) had been defined. In this section, all these principles are presented together and derived using the integral formulation by considering an arbitrary fixed part of the material. In the form of differential equations, the principles are sometimes referred to as *local principles*. In the form of integrals, they are known as *global principles*. Under the assumption of smoothness of functions involved, the two forms are completely equivalent, and in fact the requirement that the global theorem is to be valid for each and every part of the continuum results in the same differential form of the principles, as shown in this section. The purpose of this section is simply to provide an alternate approach to the formulation of the field equations and to group all the field equations for a continuum in one section for easy reference. We begin by deriving the conservation of mass equation by following a fixed part of the material.

(I) The conservation of mass principle states that the rate of increase of mass in a fixed part of a material is always zero. That is, the material derivative of the mass in any fixed part of the material is zero:

$$\frac{D}{Dt} \int_{V_m} \rho dV = 0. \quad (4.18.1)$$

In the preceding equation, ρ denotes density and V_m denotes the material volume that moves with the material. Now,

$$\frac{D}{Dt} \int_{V_m} \rho dV = \int_{V_m=V_c} \left[\frac{D}{Dt} (\rho dV) \right] = \int_{V_c} \left[\frac{D\rho}{Dt} dV + \rho \frac{DdV}{Dt} \right] = 0. \quad (4.18.2)$$

In the preceding equation, V_c denotes the so-called control volume, which instantaneously coincides with the material volume V_m . In Section 3.13, we had [see Eq. (3.13.14)]

$$\frac{1}{dV} \frac{D}{Dt} dV = \frac{\partial v_i}{\partial x_i} = \text{div } \mathbf{v}. \quad (4.18.3)$$

Thus, Eq. (4.18.2) becomes

$$\int_{V_c} \left(\frac{D\rho}{Dt} + \rho \text{div } \mathbf{v} \right) dV = 0 \quad \text{or} \quad \int_{V_c} \left(\frac{\partial \rho}{\partial t} + \text{div}(\rho \mathbf{v}) \right) dV = 0. \quad (4.18.4)$$

Equation (4.18.4) must be valid for all V_c , therefore, the integrand must be zero. That is,

$$\frac{D\rho}{Dt} + \rho \text{div } \mathbf{v} = 0 \quad \text{or} \quad \frac{\partial \rho}{\partial t} + \text{div}(\rho \mathbf{v}) = 0. \quad (4.18.5)$$

This is the same as Eq. (3.15.4).

To derive the other four principles by considering a fixed part of a material, we will need the divergence theorem, which we state as follows without proof:

$$\int_{V_c} \text{div } \mathbf{v} dV = \int_{S_c} \mathbf{v} \cdot \mathbf{n} dS \quad \text{or} \quad \int_{V_c} \frac{\partial v_j}{\partial x_j} dV = \int_{S_c} v_j n_j dS, \quad (4.18.6)$$

$$\int_{V_c} \text{div } \mathbf{T} dV = \int_{S_c} \mathbf{T} \mathbf{n} dS \quad \text{or} \quad \int_{V_c} \frac{\partial T_{ij}}{\partial x_j} dV = \int_{S_c} T_{ij} n_j dV. \quad (4.18.7)$$

For a discussion of this theorem, refer to the first two sections of Chapter 7.

In the preceding equations, \mathbf{v} and \mathbf{T} are vector and tensor, respectively; \mathbf{n} is a unit *outward* normal vector, and V_c and S_c denote control volume and the corresponding control surface. We note that using the divergence theorem, the second equation in Eq. (4.18.4) becomes

$$\frac{\partial}{\partial t} \int_{V_c} \rho dV = - \int_{S_c} (\rho \mathbf{v} \cdot \mathbf{n}) dS, \quad (4.18.8)$$

which states that the rate of increase of mass inside a control volume must be equal the rate at which the mass enters the control volume. Eq. (4.18.8) is often used as the starting point to derive Eq. (4.18.5) by using the divergence theorem.

(II) The principle of linear momentum states that the forces acting on a fixed part of a material must equal the rate of change of linear momentum of the part:

$$\frac{D}{Dt} \int_{V_m} \rho \mathbf{v} dV = \int_{S_c} \mathbf{t} dS + \int_{V_c} \rho \mathbf{B} dV = \int_{S_c} \mathbf{T} \mathbf{n} dS + \int_{V_c} \rho \mathbf{B} dV, \quad (4.18.9)$$

where \mathbf{t} , \mathbf{T} , \mathbf{B} and \mathbf{v} are stress vector, stress tensor, body force per unit mass and velocity, respectively. Now

$$\frac{D}{Dt} \int_{V_m} \rho \mathbf{v} dV = \int_{V_m} \left[\frac{D}{Dt} (\rho \mathbf{v} dV) \right] = \int_{V_m=V_c} \left[\mathbf{v} \frac{D}{Dt} (\rho dV) + \frac{D\mathbf{v}}{Dt} \rho dV \right] = \int_{V_c} \frac{D\mathbf{v}}{Dt} \rho dV, \quad (4.18.10)$$

where $(D/Dt)(\rho dV) = 0$ in accordance with the principle of conservation of mass.

Using the divergence theorem, the right side of Eq. (4.18.9) becomes

$$\int_{V_c} \operatorname{div} \mathbf{T} dV + \int_{V_c} \rho \mathbf{B} dV,$$

so that Eq. (4.18.9) becomes

$$\int_{V_c} \left[\rho \frac{D\mathbf{v}}{Dt} - \operatorname{div} \mathbf{T} - \rho \mathbf{B} \right] dV = 0. \quad (4.18.11)$$

This equation is to be valid for all V_c , therefore,

$$\rho \frac{D\mathbf{v}}{Dt} = \operatorname{div} \mathbf{T} + \rho \mathbf{B}. \quad (4.18.12)$$

This is the same as Eq. (4.7.4).

(III) The principle of moment of momentum states that the moments about a fixed point of all the forces acting on a fixed part of a material must equal the rate of change of moment of momentum of the part about the same point:

$$\frac{D}{Dt} \int_{V_m} \mathbf{x} \times \rho \mathbf{v} dV = \int_{S_c} \mathbf{x} \times \mathbf{t} dS + \int_{V_c} \mathbf{x} \times \rho \mathbf{B} dV = \int_{S_c} (\mathbf{x} \times \mathbf{Tn}) dS + \int_{V_c} \mathbf{x} \times \rho \mathbf{B} dV, \quad (4.18.13)$$

where \mathbf{x} is the position vector. Again, since $(D/Dt)(\rho dV) = 0$, the left side of Eq. (4.18.13) becomes

$$\begin{aligned} \frac{D}{Dt} \int_{V_m} \mathbf{x} \times \rho \mathbf{v} dV &= \int_{V_m=V_c} \left[\frac{D}{Dt} (\mathbf{x} \times \rho \mathbf{v} dV) \right] = \int_{V_c} \left[\mathbf{v} \times \rho \mathbf{v} dV + \mathbf{x} \times \frac{D}{Dt} (\rho \mathbf{v} dV) \right] \\ &= \int_{V_c} \left[\mathbf{x} \times \mathbf{v} \frac{D}{Dt} (\rho dV) + \mathbf{x} \times \frac{D\mathbf{v}}{Dt} \rho dV \right] = \int_{V_c} \mathbf{x} \times \frac{D\mathbf{v}}{Dt} \rho dV. \end{aligned} \quad (4.18.14)$$

Since $\mathbf{x} \times \mathbf{Tn} = \mathbf{e}_i \varepsilon_{ijk} x_j (\mathbf{Tn})_k = \mathbf{e}_i \varepsilon_{ijk} x_j T_{km} n_m$, by using the divergence theorem we obtain

$$\int_{S_c} \mathbf{x} \times \mathbf{Tn} dS = \mathbf{e}_i \int_{S_c} (\varepsilon_{ijk} x_j T_{km}) n_m dS = \mathbf{e}_i \int_{V_c} \frac{\partial \varepsilon_{ijk} x_j T_{km}}{\partial x_m} dV. \quad (4.18.15)$$

Now, $\partial x_i / \partial x_m = \delta_{im}$; therefore,

$$\begin{aligned} \int_{S_c} \mathbf{x} \times \mathbf{Tn} dS &= \mathbf{e}_i \int_{V_c} \frac{\partial \varepsilon_{ijk} x_j T_{km}}{\partial x_m} dV = \int_{V_c} \mathbf{e}_i \varepsilon_{ijk} x_j \frac{\partial T_{km}}{\partial x_m} dV + \int_{V_c} \mathbf{e}_i \varepsilon_{ijk} T_{kj} dV \\ &= \int_{V_c} \mathbf{x} \times \operatorname{div} \mathbf{T} dV + \int_{V_c} \mathbf{e}_i \varepsilon_{ijk} T_{kj} dV. \end{aligned} \quad (4.18.16)$$

Thus, Eq. (4.18.13) becomes

$$\int_{V_c} \mathbf{x} \times \frac{D\mathbf{v}}{Dt} \rho dV = \int_{V_c} \mathbf{x} \times (\operatorname{div} \mathbf{T} + \rho \mathbf{B}) dV + \int_{V_c} \mathbf{e}_i \varepsilon_{ijk} T_{kj} dV, \quad (4.18.17)$$

or

$$\int_{V_c} \mathbf{x} \times \left(\rho \frac{D\mathbf{v}}{Dt} - \operatorname{div} \mathbf{T} - \rho \mathbf{B} \right) dV + \int_{V_c} \mathbf{e}_i \varepsilon_{ijk} T_{kj} dV = 0. \quad (4.18.18)$$

But the linear momentum equation gives $\rho \frac{D\mathbf{v}}{Dt} - \text{div}\mathbf{T} - \rho\mathbf{B} = \mathbf{0}$. Thus, Eq. (4.18.18) becomes $\int_{V_c} \mathbf{e}_i \varepsilon_{ijk} T_{kj} dV = 0$, so that

$$\varepsilon_{ijk} T_{kj} = 0. \quad (4.18.19)$$

From which we arrive at the symmetry of stress tensor. That is,

$$T_{12} - T_{21} = 0, \quad T_{23} - T_{32} = 0, \quad T_{31} - T_{13} = 0. \quad (4.18.20)$$

This same result was obtained in Section 4.4.

(IV) The conservation of energy principle states that the rate of increase of kinetic energy and internal energy in a fixed part of a material must equal the sum of the rate of work by surface and body forces, rate of heat inflow across the boundary, and heat supply within:

$$\frac{D}{Dt} \int_{V_m} \left(\frac{\rho v^2}{2} + \rho u \right) dV = \int_{S_c} (\mathbf{t} \cdot \mathbf{v}) dS + \int_{V_c} \rho \mathbf{B} \cdot \mathbf{v} dV - \int_{S_c} (\mathbf{q} \cdot \mathbf{n}) dS + \int_{V_c} \rho q_s dV, \quad (4.18.21)$$

where u is the internal energy per unit mass, \mathbf{q} the heat flux vector, and q_s the heat supply per unit mass. We note that with \mathbf{n} being an outward unit normal vector, $(-\mathbf{q} \cdot \mathbf{n})$ represents rate of heat inflow. Again, $(D/Dt)(\rho dV) = 0$; therefore, the left side becomes

$$\frac{D}{Dt} \int_{V_m} \rho \left(\frac{v^2}{2} + u \right) dV = \int_{V_m=V_c} \left[\frac{D}{Dt} \left(\frac{v^2}{2} + u \right) \right] \rho dV. \quad (4.18.22)$$

Now,

$$\int_{S_c} \mathbf{t} \cdot \mathbf{v} dS = \int_{S_c} \mathbf{T}\mathbf{n} \cdot \mathbf{v} dS = \int_{S_c} \mathbf{n} \cdot \mathbf{T}^T \mathbf{v} dS = \int_{V_c} \text{div}(\mathbf{T}^T \mathbf{v}) dV, \quad (4.18.23)$$

$$\text{div}(\mathbf{T}^T \mathbf{v}) = \frac{\partial T_{ji} v_j}{\partial x_i} = \frac{\partial T_{ji}}{\partial x_i} v_j + T_{ji} \frac{\partial v_j}{\partial x_i} = (\text{div} \mathbf{T}) \cdot \mathbf{v} + \text{tr}(\mathbf{T}^T \nabla \mathbf{v}), \quad (4.18.24)$$

and $\int_{S_c} \mathbf{q} \cdot \mathbf{n} dS = \int_{V_c} (\text{div} \mathbf{q}) dV$, therefore, Eq. (4.18.21) becomes

$$\int_{V_c} \rho \frac{D}{Dt} \left(\frac{v^2}{2} + u \right) dV = \int_{V_c} [(\text{div} \mathbf{T} + \rho \mathbf{B}) \cdot \mathbf{v} + \text{tr}(\mathbf{T}^T \nabla \mathbf{v}) - \text{div} \mathbf{q} + \rho q_s] dV. \quad (4.18.25)$$

But $(\text{div} \mathbf{T} + \rho \mathbf{B}) \cdot \mathbf{v} = \rho (D\mathbf{v}/Dt) \cdot \mathbf{v} = (1/2)\rho (Dv^2/Dt)$, therefore, Eq. (4.18.25) becomes

$$\int_{V_c} \rho \frac{Du}{Dt} dV = \int_{V_c} [\text{tr}(\mathbf{T}^T \nabla \mathbf{v}) - \text{div} \mathbf{q} + \rho q_s] dV. \quad (4.18.26)$$

For this equation to be valid for all V_c , we must have

$$\rho \frac{Du}{Dt} = \text{tr}(\mathbf{T}^T \nabla \mathbf{v}) - \text{div} \mathbf{q} + \rho q_s. \quad (4.18.27)$$

This is the same as Eq. (4.15.4).

(V) The entropy inequality states that the rate of increase of entropy in a fixed part of a material is not less than the influx of entropy, \mathbf{q}/Θ , across the surface of the part plus the entropy supply within the volume:

$$\frac{D}{Dt} \int_{V_m} \rho \eta dV \geq - \int_{S_c} \frac{\mathbf{q}}{\Theta} \cdot \mathbf{n} dS + \int_{V_c} \frac{\rho q_s}{\Theta} dV, \quad (4.18.28)$$

where η is the entropy per unit mass, and other symbols have the same meanings as before. Now, again, $(D/Dt)(\rho dV) = 0$, therefore,

$$\frac{D}{Dt} \int_{V_m} \rho \eta dV = \int_{V_c} \frac{D\eta}{Dt} \rho dV. \quad (4.18.29)$$

Using the divergence theorem, we have $\int_{S_c} (\mathbf{q}/\Theta) \cdot \mathbf{n} dS = \int_{V_c} \text{div}(\mathbf{q}/\Theta) dV$; thus, the inequality (4.18.29) becomes

$$\int_{V_c} \rho \frac{D\eta}{Dt} dV \geq - \int_{V_c} \text{div} \left(\frac{\mathbf{q}}{\Theta} \right) dV + \int_{V_c} \frac{\rho q_s}{\Theta} dV, \quad (4.18.30)$$

so that

$$\rho \frac{D\eta}{Dt} \geq -\text{div} \left(\frac{\mathbf{q}}{\Theta} \right) + \frac{\rho q_s}{\Theta}. \quad (4.18.31)$$

This is the same as Eq. (4.16.2).

We remark that later, in Chapter 7, we revisit the derivations of the integral form of the principles with emphasis on Reynold's transport theorem and its applications to obtain the approximate solutions of engineering problems using the concept of moving as well as fixed control volumes.

APPENDIX 4.1: DETERMINATION OF MAXIMUM SHEARING STRESS AND THE PLANES ON WHICH IT ACTS

This appendix gives the details of solving the following system of four nonlinear algebraic equations in n_1 , n_2 , n_3 and λ :

$$2n_1 [T_1^2 - 2(T_1 n_1^2 + T_2 n_2^2 + T_3 n_3^2) T_1] = n_1 \lambda, \quad (i)$$

$$2n_2 [T_2^2 - 2(T_1 n_1^2 + T_2 n_2^2 + T_3 n_3^2) T_2] = n_2 \lambda, \quad (ii)$$

$$2n_3 [T_3^2 - 2(T_1 n_1^2 + T_2 n_2^2 + T_3 n_3^2) T_3] = n_3 \lambda, \quad (iii)$$

$$n_1^2 + n_2^2 + n_3^2 = 1. \quad (iv)$$

These are Eqs. (4.6.12), (4.6.13), (4.6.14), and (4.6.7) in Section 4.6 for the determination of the maximum shearing stress and the plane(s) on which it acts. This system of equations determines all stationary values of T_s^2 from Eq. (4.6.5), which is repeated here:

$$T_s^2 = T_1^2 n_1^2 + T_2^2 n_2^2 + T_3^2 n_3^2 - (T_1 n_1^2 + T_2 n_2^2 + T_3 n_3^2)^2. \quad (v)$$

From the stationary values of T_s^2 , the maximum and the minimum values of T_s are obtained. The following are the details:

1. Case I: $T_1 = T_2 = T_3 = T$. In this case, Eqs. (i), (ii), and (iii) reduce to the following three equations:

$$-2n_1 T^2 = n_1 \lambda, \quad -2n_2 T^2 = n_2 \lambda, \quad -2n_3 T^2 = n_3 \lambda.$$

These equations show that (i), (ii), and (iii) are satisfied for arbitrary values of (n_1, n_2, n_3) with $\lambda = -2T^2$ and $n_1^2 + n_2^2 + n_3^2 = 1$. Eq. (v) gives $T_s^2 = 0$ for this case. This is to be expected because with

$T_1 = T_2 = T_3$, every plane is a principal plane having zero shearing stress on it. In this case, $T_s^2 = 0$ is both the maximum and the minimum value of T_s^2 and of T_s . We note that although we get a value for the Lagrangian multiplier $\lambda = -2T^2$, it does not have any significance and can be simply ignored.

2. Case II: Only two of the T_i s are the same.

(a) If $T_1 = T_2 \neq T_3$,

$$\text{Equation (i) becomes } 2n_1[-T_1^2 + 2(T_1 - T_3)T_1n_3^2] = n_1\lambda. \quad (\text{vi})$$

$$\text{Equation (ii) becomes } 2n_2[-T_1^2 + 2(T_1 - T_3)T_1n_3^2] = n_2\lambda. \quad (\text{vii})$$

$$\text{Equation (iii) becomes } 2n_3[T_3^2 - 2T_1T_3 + (2T_1T_3 - 2T_3^2)n_3^2] = n_3\lambda. \quad (\text{viii})$$

From the preceding three equations, we see that if $n_3 = 0$, any $(n_1, n_2, 0)$ with $n_1^2 + n_2^2 = 1$ is a solution with $\lambda = -2T_1^2$ and $T_s^2 = 0$ [from Eq. (v)]. We note that all these planes are principal planes, including $(1, 0, 0)$ and $(0, 1, 0)$.

If $n_3 \neq 0$, in addition to the obvious solution $(0, 0, \pm 1)$, there are also solutions from the following [see Eqs. (vi) and (viii)]:

$$2[-T_1^2 + 2(T_1 - T_3)T_1n_3^2] = 2[T_3^2 - 2T_1T_3 + (2T_1T_3 - 2T_3^2)n_3^2] = \lambda.$$

Rearranging the preceding equation, we have

$$[2(T_1 - T_3)T_1n_3^2] = [(T_1 - T_3)^2 + 2(T_1 - T_3)T_3n_3^2],$$

which leads to

$$2n_3^2 = 1,$$

and

$$T_s^2 = T_1^2(1 - n_3^2) + T_3^2n_3^2 - (T_1(1 - n_3^2) + T_3n_3^2)^2 = \frac{(T_1 - T_3)^2}{4} = \frac{(T_2 - T_3)^2}{4}.$$

Thus, if $T_1 = T_2 \neq T_3$, the solutions are

$$(n_1, n_2, 0), \text{ any } n_1, n_2 \text{ satisfying } n_1^2 + n_2^2 = 1, T_s^2 = 0, \quad (\text{ix})$$

and

$$(n_1, n_2, \pm\sqrt{1/2}), \text{ any } n_1, n_2 \text{ satisfying } n_1^2 + n_2^2 + 1/2 = 1, T_s^2 = \frac{(T_1 - T_3)^2}{4} = \frac{(T_2 - T_3)^2}{4}. \quad (\text{x})$$

(b) If $T_2 = T_3 \neq T_1$, the solutions are

$$(0, n_2, n_3), \text{ for any } n_2, n_3 \text{ satisfying } n_2^2 + n_3^2 = 1 \text{ and } T_s^2 = 0 \text{ on those planes.} \quad (\text{xi})$$

$$(\pm\sqrt{1/2}, n_2, n_3), \text{ for any } n_2, n_3 \text{ satisfying } 1/2 + n_2^2 + n_3^2 = 1 \text{ and}$$

$$T_s^2 = \frac{(T_2 - T_1)^2}{4} = \frac{(T_3 - T_1)^2}{4} \text{ on those planes.} \quad (\text{xii})$$

(c) If $T_3 = T_1 \neq T_2$, the solutions are

$$(n_1, 0, n_3), \text{ for any } n_1, n_3 \text{ satisfying } n_1^2 + n_3^2 = 1 \text{ and } T_s^2 = 0 \text{ on those planes,} \quad (\text{xiii})$$

$$(n_1, \pm\sqrt{1/2}, n_3), \text{ for any } n_1, n_3 \text{ satisfying } n_1^2 + 1/2 + n_3^2 = 1 \text{ and}$$

$$T_s^2 = \frac{(T_3 - T_2)^2}{4} = \frac{(T_1 - T_2)^2}{4} \text{ on those planes.} \quad (\text{xiv})$$

3. Case III: All three T_i are distinct. In this case, at least one of the three n_1, n_2, n_3 must be zero. To show this, we first assume that neither n_1 nor n_2 are zero; then Eqs. (i) and (ii) give

$$2[T_1^2 - 2(T_1n_1^2 + T_2n_2^2 + T_3n_3^2)T_1] = 2[T_2^2 - 2(T_1n_1^2 + T_2n_2^2 + T_3n_3^2)T_2] = \lambda,$$

thus,

$$T_1^2 - T_2^2 = 2(T_1n_1^2 + T_2n_2^2 + T_3n_3^2)(T_1 - T_2).$$

Since $T_1 \neq T_2$,

$$T_1 + T_2 = 2(T_1n_1^2 + T_2n_2^2 + T_3n_3^2).$$

If n_3 is also not zero, then we also have

$$T_1 + T_3 = 2(T_1n_1^2 + T_2n_2^2 + T_3n_3^2) \quad \text{and} \quad T_2 + T_3 = 2(T_1n_1^2 + T_2n_2^2 + T_3n_3^2).$$

In other words,

$$T_1 + T_2 = T_1 + T_3 = T_2 + T_3.$$

from which we see that $T_1 = T_2 = T_3$, which contradicts the assumption that all three T_i are distinct. Therefore, if all three T_i s are distinct, at least one of the three n_i s must be zero. If two of the n_i s are zero, we obviously have the following three cases:

$$\text{(a) } (n_1, n_2, n_3) = (\pm 1, 0, 0), \lambda = -2T_1^2, T_s = 0. \quad (\text{xv})$$

$$\text{(b) } (n_1, n_2, n_3) = (0, \pm 1, 0), \lambda = -2T_2^2, T_s = 0. \quad (\text{xvi})$$

$$\text{(c) } (n_1, n_2, n_3) = (0, 0, \pm 1), \lambda = -2T_3^2, T_s = 0. \quad (\text{xvii})$$

If only n_3 is zero, then Eqs. (i) and (ii) give

$$2[T_1^2 - 2(T_1n_1^2 + T_2n_2^2)T_1] = 2[T_2^2 - 2(T_1n_1^2 + T_2n_2^2)T_2] = \lambda,$$

or

$$T_1^2 - T_2^2 = 2(T_1n_1^2 + T_2n_2^2)(T_1 - T_2).$$

Since $T_1 \neq T_2$ and $n_1^2 + n_2^2 = 1$, the preceding equation becomes

$$T_1 + T_2 = 2(T_1n_1^2 + T_2n_2^2) = 2[T_1n_1^2 + T_2(1 - n_1^2)].$$

Thus,

$$T_1 - T_2 = 2n_1^2(T_1 - T_2) \quad \text{or} \quad 1 = 2n_1^2.$$

Therefore, $n_1 = \pm\sqrt{1/2}$ and $n_2 = \pm\sqrt{1/2}$, i.e.,

$$(d) (n_1, n_2, n_3) = \pm(1/\sqrt{2}, \pm 1/\sqrt{2}, 0), T_s^2 = \frac{(T_1 - T_2)^2}{4}. \quad (\text{xviii})$$

Similarly, we also have

$$(e) (n_1, n_2, n_3) = \pm(1/\sqrt{2}, 0, \pm 1/\sqrt{2}), T_s^2 = \frac{(T_1 - T_3)^2}{4}. \quad (\text{xix})$$

$$(f) (n_1, n_2, n_3) = \pm(0, 1/\sqrt{2}, \pm 1/\sqrt{2}), T_s^2 = \frac{(T_2 - T_3)^2}{4}. \quad (\text{xx})$$

PROBLEMS FOR CHAPTER 4

4.1 The state of stress at a certain point in a body is given by

$$[\mathbf{T}] = \begin{bmatrix} 1 & 2 & 3 \\ 2 & 4 & 5 \\ 3 & 5 & 0 \end{bmatrix}_{\mathbf{e}_i} \text{ MPa.}$$

On each of the coordinate planes (with normal in \mathbf{e}_1 , \mathbf{e}_2 , \mathbf{e}_3 directions), (a) what is the normal stress?
(b) What is the total shearing stress?

4.2 The state of stress at a certain point in a body is given by

$$[\mathbf{T}] = \begin{bmatrix} 2 & -1 & 3 \\ -1 & 4 & 0 \\ 3 & 0 & -1 \end{bmatrix}_{\mathbf{e}_i} \text{ MPa.}$$

(a) Find the stress vector at a point on the plane whose normal is in the direction of $2\mathbf{e}_1 + 2\mathbf{e}_2 + \mathbf{e}_3$.
(b) Determine the magnitude of the normal and shearing stresses on this plane.

4.3 Do the previous problem for a plane passing through the point and parallel to the plane $x_1 - 2x_2 + 3x_3 = 4$.

4.4 The stress distribution in a certain body is given by

$$[\mathbf{T}] = \begin{bmatrix} 0 & 100x_1 & -100x_2 \\ 100x_1 & 0 & 0 \\ -100x_2 & 0 & 0 \end{bmatrix} \text{ MPa.}$$

Find the stress vector acting on a plane that passes through the point $(1/2, \sqrt{3}/2, 3)$ and is tangent to the circular cylindrical surface $x_1^2 + x_2^2 = 1$ at that point.

4.5 Given $T_{11} = 1 \text{ MPa}$, $T_{22} = -1 \text{ MPa}$, and all other $T_{ij} = 0$ at a point in a continuum.

(a) Show that the only plane on which the stress vector is zero is the plane with normal stress in the \mathbf{e}_3 direction.

(b) Give three planes on which no normal stress is acting.

4.6 For the following state of stress:

$$[\mathbf{T}] = \begin{bmatrix} 10 & 50 & -50 \\ 50 & 0 & 0 \\ -50 & 0 & 0 \end{bmatrix} \text{ MPa.}$$

Find T'_{11} and T'_{13} , where \mathbf{e}'_1 is in the direction of $\mathbf{e}_1 + 2\mathbf{e}_2 + 3\mathbf{e}_3$ and \mathbf{e}'_2 is in the direction of $\mathbf{e}_1 + \mathbf{e}_2 - \mathbf{e}_3$.

4.7 Consider the following stress distribution:

$$[\mathbf{T}] = \begin{bmatrix} \alpha x_2 & \beta & 0 \\ \beta & 0 & 0 \\ 0 & 0 & 0 \end{bmatrix},$$

where α and β are constants.

- (a) Determine and sketch the distribution of the stress vector acting on the square in the $x_1 = 0$ plane with vertices located at $(0, 1, 1)$, $(0, -1, 1)$, $(0, 1, -1)$, and $(0, -1, -1)$.
 (b) Find the total resultant force and moment about the origin of the stress vectors acting on the square of part (a).

4.8 Do the previous problem if the stress distribution is given by $T_{11} = \alpha x_2^2$ and all other $T_{ij} = 0$.

4.9 Do Prob. 4.7 for the stress distribution $T_{11} = \alpha$, $T_{12} = T_{21} = \alpha X_3$ and all other $T_{ij} = 0$.

4.10 Consider the following stress distribution for a circular cylindrical bar:

$$[\mathbf{T}] = \begin{bmatrix} 0 & -\alpha x_3 & \alpha x_2 \\ -\alpha x_3 & 0 & 0 \\ \alpha x_2 & 0 & 0 \end{bmatrix}.$$

- (a) What is the distribution of the stress vector on the surfaces defined by (i) the lateral surface $x_2^2 + x_3^2 = 4$, (ii) the end face $x_1 = 0$, and (iii) the end face $x_1 = l$?
 (b) Find the total resultant force and moment on the end face $x_1 = l$.

4.11 An elliptical bar with lateral surface defined by $x_2^2 + 2x_3^2 = 1$ has the following stress distribution:

$$[\mathbf{T}] = \begin{bmatrix} 0 & -2x_3 & x_2 \\ -2x_3 & 0 & 0 \\ x_2 & 0 & 0 \end{bmatrix}.$$

- (a) Show that the stress vector at any point (x_1, x_2, x_3) on the lateral surface is zero.
 (b) Find the resultant force, and resultant moment, about the origin O of the stress vector on the left end face $x_1 = 0$.

Note:

$$\int x_2^2 dA = \frac{\pi}{4\sqrt{2}} \quad \text{and} \quad \int x_3^2 dA = \frac{\pi}{8\sqrt{2}}.$$

4.12 For any stress state \mathbf{T} we define the deviatoric stress \mathbf{S} to be $\mathbf{S} = \mathbf{T} - (T_{kk}/3)\mathbf{I}$, where T_{kk} is the first invariant of the stress tensor \mathbf{T} .

- (a) Show that the first invariant of the deviatoric stress vanishes.

(b) Evaluate \mathbf{S} for the stress tensor:

$$[\mathbf{T}] = 100 \begin{bmatrix} 6 & 5 & -2 \\ 5 & 3 & 4 \\ -2 & 4 & 9 \end{bmatrix} \text{ kPa}.$$

(c) Show that the principal directions of the stress tensor coincide with those of the deviatoric stress tensor.

4.13 An octahedral stress plane is one whose normal makes equal angles with each of the principal axes of stress.

(a) How many independent octahedral planes are there at each point?

(b) Show that the normal stress on an octahedral plane is given by one-third the first stress invariant.

(c) Show that the shearing stress on the octahedral plane is given by

$$T_s = \frac{1}{3} \left[(T_1 - T_2)^2 + (T_2 - T_3)^2 + (T_3 - T_1)^2 \right]^{1/2},$$

where T_1, T_2, T_3 are principal values of the stress tensor.

4.14 (a) Let \mathbf{m} and \mathbf{n} be two unit vectors that define two planes M and N that pass through a point P . For an arbitrary state of stress defined at the point P , show that the component of the stress vector \mathbf{t}_m in the \mathbf{n} direction is equal to the component of the stress vector \mathbf{t}_n in the \mathbf{m} direction.

(b) If $\mathbf{m} = \mathbf{e}_1$ and $\mathbf{n} = \mathbf{e}_2$, what do the results of (a) reduce to?

4.15 Let \mathbf{m} be a unit vector that defines a plane M passing through a point P . Show that the stress vector on any plane that contains the stress traction \mathbf{t}_m lies in the M plane.

4.16 Let \mathbf{t}_m and \mathbf{t}_n be stress vectors on planes defined by the unit vector \mathbf{m} and \mathbf{n} , respectively, and pass through the point P . Show that if \mathbf{k} is a unit vector that determines a plane that contains \mathbf{t}_m and \mathbf{t}_n , then \mathbf{t}_k is perpendicular to \mathbf{m} and \mathbf{n} .

4.17 Given the function $f(x, y) = 4 - x^2 - y^2$, find the maximum value of f subjected to the constraint that $x + y = 2$.

4.18 True or false:

(i) Symmetry of stress tensor is not valid if the body has an angular acceleration.

(ii) On the plane of maximum normal stress, the shearing stress is always zero.

4.19 True or false:

(i) On the plane of maximum shearing stress, the normal stress is always zero.

(ii) A plane with its normal in the direction of $\mathbf{e}_1 + 2\mathbf{e}_2 - 2\mathbf{e}_3$ has a stress vector $\mathbf{t} = 50\mathbf{e}_1 + 100\mathbf{e}_2 - 100\mathbf{e}_3$ MPa. It is a principal plane.

4.20 Why can the following two matrices not represent the same stress tensor?

$$\begin{bmatrix} 100 & 200 & 40 \\ 200 & 0 & 0 \\ 40 & 0 & -50 \end{bmatrix} \text{ MPa} \quad \begin{bmatrix} 40 & 100 & 60 \\ 100 & 100 & 0 \\ 60 & 0 & 20 \end{bmatrix} \text{ MPa}.$$

4.21 Given:

$$[\mathbf{T}] = \begin{bmatrix} 0 & 100 & 0 \\ 100 & 0 & 0 \\ 0 & 0 & 0 \end{bmatrix} \text{ MPa}.$$

- (a) Find the magnitude of shearing stress on the plane whose normal is in the direction of $\mathbf{e}_1 + \mathbf{e}_2$.
 (b) Find the maximum and minimum normal stresses and the planes on which they act.
 (c) Find the maximum shearing stress and the plane on which it acts.

4.22 Show that the equation for the normal stress on the plane of maximum shearing stress is

$$T_n = \frac{(T_n)_{\max} + (T_n)_{\min}}{2}$$

- 4.23** The stress components at a point are given by $T_{11} = 100 \text{ MPa}$, $T_{22} = 300 \text{ MPa}$, $T_{33} = 400 \text{ MPa}$, $T_{12} = T_{13} = T_{23} = 0$.
 (a) Find the maximum shearing stress and the planes on which they act.
 (b) Find the normal stress on these planes.
 (c) Are there any plane(s) on which the normal stress is 500 MPa ?
- 4.24** The principal values of a stress tensor \mathbf{T} are $T_1 = 10 \text{ MPa}$, $T_2 = -10 \text{ MPa}$, and $T_3 = 30 \text{ MPa}$. If the matrix of the stress is given by

$$[\mathbf{T}] = \begin{bmatrix} T_{11} & 0 & 0 \\ 0 & 1 & 2 \\ 0 & 2 & T_{33} \end{bmatrix} \times 10 \text{ MPa},$$

find the values of T_{11} and T_{33} .

4.25 If the state of stress at a point is

$$[\mathbf{T}] = \begin{bmatrix} 300 & 0 & 0 \\ 0 & -200 & 0 \\ 0 & 0 & 400 \end{bmatrix} \text{ kPa},$$

find (a) the magnitude of the shearing stress on the plane whose normal is in the direction of $(2\mathbf{e}_1 + 2\mathbf{e}_2 + \mathbf{e}_3)$ and (b) the maximum shearing stress.

4.26 Given:

$$[\mathbf{T}] = \begin{bmatrix} 1 & 4 & 0 \\ 4 & 1 & 0 \\ 0 & 0 & 1 \end{bmatrix} \text{ MPa}.$$

- (a) Find the stress vector on the plane whose normal is in the direction of $\mathbf{e}_1 + \mathbf{e}_2$.
 (b) Find the normal stress on the same plane.
 (c) Find the magnitude of the shearing stress on the same plane.
 (d) Find the maximum shearing stress and the planes on which this maximum shearing stress acts.
- 4.27** The stress state in which the only nonvanishing stress components are a single pair of shearing stresses is called simple shear. Take $T_{12} = T_{21} = \tau$ and all other $T_{ij} = 0$.
 (a) Find the principal values and principal directions of this stress state.
 (b) Find the maximum shearing stress and the planes on which it acts.
- 4.28** The stress state in which only the three normal stress components do not vanish is called a *triaxial state of stress*. Take $T_{11} = \sigma_1$, $T_{22} = \sigma_2$, $T_{33} = \sigma_3$ with $\sigma_1 > \sigma_2 > \sigma_3$ and all other $T_{ij} = 0$. Find the maximum shearing stress and the plane on which it acts.

- 4.29 Show that the symmetry of the stress tensor is not valid if there are body moments per unit volume, as in the case of a polarized anisotropic dielectric solid.
- 4.30 Given the following stress distribution:

$$[\mathbf{T}] = \begin{bmatrix} x_1 + x_2 & T_{12}(x_1, x_2) & 0 \\ T_{12}(x_1, x_2) & x_1 - 2x_2 & 0 \\ 0 & 0 & x_2 \end{bmatrix},$$

find T_{12} so that the stress distribution is in equilibrium with zero body force and so that the stress vector on the plane $x_1 = 1$ is given by $\mathbf{t} = (1 + x_2)\mathbf{e}_1 + (5 - x_2)\mathbf{e}_2$.

- 4.31 Consider the following stress tensor:

$$[\mathbf{T}] = \alpha \begin{bmatrix} x_2 & -x_3 & 0 \\ -x_3 & 0 & -x_2 \\ 0 & -x_2 & T_{33} \end{bmatrix}.$$

Find an expression for T_{33} such that the stress tensor satisfies the equations of equilibrium in the presence of the body force $\mathbf{B} = -g\mathbf{e}_3$, where g is a constant.

- 4.32 In the absence of body forces, the equilibrium stress distribution for a certain body is

$$T_{11} = Ax_2, \quad T_{12} = T_{21} = x_1, \quad T_{22} = Bx_1 + Cx_2, \quad T_{33} = (T_{11} + T_{22})/2, \quad \text{all other } T_{ij} = 0.$$

Also, the boundary plane $x_1 - x_2 = 0$ for the body is free of stress. (a) Find the value of C and (b) determine the value of A and B .

- 4.33 In the absence of body forces, do the following stress components satisfy the equations of equilibrium?

$$T_{11} = \alpha[x_2^2 + \nu(x_1^2 - x_2^2)], \quad T_{22} = \alpha[x_1^2 + \nu(x_2^2 - x_1^2)], \quad T_{33} = \alpha\nu(x_1^2 + x_2^2), \\ T_{12} = T_{21} = -2\nu\alpha x_1 x_2, \quad T_{13} = T_{31} = 0, \quad T_{23} = T_{32} = 0.$$

- 4.34 Repeat the previous problem for the stress distribution:

$$[\mathbf{T}] = \alpha \begin{bmatrix} x_1 + x_2 & 2x_1 - x_2 & 0 \\ 2x_1 - x_2 & x_1 - 3x_2 & 0 \\ 0 & 0 & x_1 \end{bmatrix}.$$

- 4.35 Suppose that the stress distribution has the form (called a *plane stress state*)

$$[\mathbf{T}] = \begin{bmatrix} T_{11}(x_1, x_2) & T_{12}(x_1, x_2) & 0 \\ T_{12}(x_1, x_2) & T_{22}(x_1, x_2) & 0 \\ 0 & 0 & 0 \end{bmatrix}.$$

- (a) If the state of stress is in equilibrium, can the body forces be dependent on x_3 ?
- (b) Demonstrate that if we introduce a function $\varphi(x_1, x_2)$ such that $T_{11} = \partial^2 \varphi / \partial x_2^2$, $T_{22} = \partial^2 \varphi / \partial x_1^2$ and $T_{12} = -\partial^2 \varphi / \partial x_1 \partial x_2$, then the equations of equilibrium are satisfied in the absence of body forces for any $\varphi(x_1, x_2)$ that is continuous up to the third derivatives.

- 4.36 In cylindrical coordinates (r, θ, z) , consider a differential volume of material bounded by the three pairs of faces: $r = r$ and $r = r + dr$; $\theta = \theta$ and $\theta = \theta + d\theta$; and $z = z$ and $z = z + dz$. Derive the r and θ equations of motion in cylindrical coordinates and compare the equations with those given in Section 4.8.

4.37 Verify that the following stress field satisfies the z -equation of equilibrium in the absence of body forces:

$$T_{rr} = A \left(\frac{z}{R^3} - \frac{3r^2 z}{R^5} \right), \quad T_{\theta\theta} = \frac{Az}{R^3}, \quad T_{zz} = -A \left(\frac{z}{R^3} + \frac{3z^3}{R^5} \right), \quad T_{rz} = -A \left(\frac{r}{R^3} + \frac{3rz^2}{R^5} \right), \quad T_{r\theta} = T_{z\theta} = 0.$$

where $R^2 = r^2 + z^2$.

4.38 Given the following stress field in cylindrical coordinates:

$$T_{rr} = -\frac{3Pzr^2}{2\pi R^5}, \quad T_{zz} = -\frac{3Pz^3}{2\pi R^5}, \quad T_{rz} = -\frac{3Pz^2 r}{2\pi R^5}, \quad T_{\theta\theta} = T_{r\theta} = T_{z\theta} = 0, \quad R^2 = r^2 + z^2.$$

Verify that the state of stress satisfies the equations of equilibrium in the absence of body forces.

4.39 For the stress field given in Example 4.9.1, determine the constants A and B if the inner cylindrical wall is subjected to a uniform pressure p_i and the outer cylindrical wall is subjected to a uniform pressure p_o .

4.40 Verify that Eqs. (4.8.4) to (4.8.6) are satisfied by the equilibrium stress field given in Example 4.9.2 in the absence of body forces.

4.41 In Example 4.9.2, if the spherical shell is subjected to an inner pressure p_i and an outer pressure p_o , determine the constant A and B .

4.42 The equilibrium configuration of a body is described by

$$x_1 = 16X_1, \quad x_2 = -\frac{1}{4}X_2, \quad x_3 = -\frac{1}{4}X_3$$

and the Cauchy stress tensor is given by $T_{11} = 1000 \text{ MPa}$, and all other $T_{ij} = 0$.

(a) Calculate the first Piola-Kirchhoff stress tensor and the corresponding pseudo-stress vector for the plane whose undeformed plane is the \mathbf{e}_1 -plane.

(b) Calculate the second Piola-Kirchhoff tensor and the corresponding pseudo-stress vector for the same plane.

4.43 Can the following equations represent a physically acceptable deformation of a body? Give reason(s).

$$x_1 = -\frac{1}{2}X_1, \quad x_2 = \frac{1}{2}X_3, \quad x_3 = -4X_2.$$

4.44 The deformation of a body is described by

$$x_1 = 4X_1, \quad x_2 = -(1/4)X_2, \quad x_3 = -(1/4)X_3.$$

(a) For a unit cube with sides along the coordinate axes, what is its deformed volume? What is the deformed area of the \mathbf{e}_1 -face of the cube?

(b) If the Cauchy stress tensor is given by $T_{11} = 100 \text{ MPa}$, and all other $T_{ij} = 0$, calculate the first Piola-Kirchhoff stress tensor and the corresponding pseudo-stress vector for the plane whose undeformed plane is the \mathbf{e}_1 -plane.

(c) Calculate the second Piola-Kirchhoff tensor and the corresponding pseudo-stress vector for the plane whose undeformed plane is the \mathbf{e}_1 -plane. Also calculate the pseudo-differential force for the same plane.

4.45 The deformation of a body is described by

$$x_1 = X_1 + kX_2, \quad x_2 = X_2, \quad x_3 = X_3.$$

- (a) For a unit cube with sides along the coordinate axes, what is its deformed volume? What is the deformed area of the \mathbf{e}_1 face of the cube?
- (b) If the Cauchy stress tensor is given by $T_{12} = T_{21} = 100 \text{ MPa}$, and all other $T_{ij} = 0$, calculate the first Piola-Kirchhoff stress tensor and the corresponding pseudo-stress vector for the plane whose undeformed plane is the \mathbf{e}_1 -plane and compare it with the Cauchy stress vector in the deformed state.
- (c) Calculate the second Piola-Kirchhoff tensor and the corresponding pseudo-stress vector for the plane whose undeformed plane is the \mathbf{e}_1 -plane. Also calculate the pseudo-differential force for the same plane.

4.46 The deformation of a body is described by

$$x_1 = 2X_1, \quad x_2 = 2X_2, \quad x_3 = 2X_3.$$

- (a) For a unit cube with sides along the coordinate axes, what is its deformed volume? What is the deformed area of the \mathbf{e}_1 face of the cube?
- (b) If the Cauchy stress tensor is given by

$$\begin{bmatrix} 100 & 0 & 0 \\ 0 & 100 & 0 \\ 0 & 0 & 100 \end{bmatrix} \text{ Mpa},$$

calculate the first Piola-Kirchhoff stress tensor and the corresponding pseudo-stress vector for the plane whose undeformed plane is the \mathbf{e}_1 -plane and compare it with the Cauchy stress vector on its deformed plane.

- (c) Calculate the second Piola-Kirchhoff tensor and the corresponding pseudo-stress vector for the plane whose undeformed plane is the \mathbf{e}_1 -plane. Also calculate the pseudo-differential force for the same plane.

The Elastic Solid

So far we have studied the kinematics of deformation, the description of the state of stress, and five basic principles of continuum physics (see Section 4.18): the principle of conservation of mass, the principle of linear momentum, the principle of moment of momentum, the principle of conservation of energy and the entropy inequality. All these relations are valid for every continuum; indeed, no mention was made of any material in the derivations.

However, these equations are not sufficient to describe the response of a specific material due to a given loading. We know from experience that under the same loading conditions, the response of steel is different from that of water. Furthermore, for a given material, it varies with different loading conditions. For example, for moderate loadings the deformation in steel caused by the application of loads disappears with the removal of the loads. This aspect of the material behavior is known as *elasticity*. Beyond a certain level of loading, there will be permanent deformations or even fracture exhibiting behavior quite different from that of elasticity.

In this chapter, we shall study idealized materials that model the elastic behavior of real solids. The constitutive equations for an isotropic linearly elastic model and some selected methods of solutions to boundary value problems in elasticity, including plane stress and plane strain solutions, as well as solutions by potential functions, are presented in Part A, followed by the formulations of the constitutive equations for anisotropic linearly elastic models in Part B and some examples of the incompressible isotropic nonlinearly elastic model in Part C.

5.1 MECHANICAL PROPERTIES

We want to establish some appreciation of the mechanical behavior of solid materials. To do this, we perform some thought experiments modeled after real laboratory experiments.

Suppose that from a block of material we cut out a slender cylindrical test specimen of cross-sectional area A . The bar is now statically tensed by an axially applied load P , and the elongation $\Delta\ell$, over some axial gage length ℓ , is measured. A typical plot of tensile force against elongation is shown in Figure 5.1-1. Within the linear portion OA (called the *proportional range*), if the load is reduced to zero (i.e., unloading), then the line OA is retraced back to O and the specimen has exhibited an *elasticity*. Applying a load that is greater than A and then unloading, we typically traverse $OABC$ and find that there is a “permanent elongation” OC . Reapplication of the load from C indicates elastic behavior with the same slope as OA but with an increased proportional limit. The material is said to have *work-hardened*.

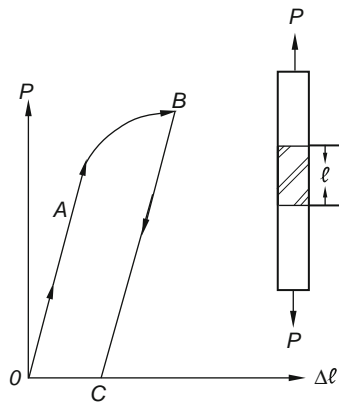

FIGURE 5.1-1

The load-elongation diagram in Figure 5.1-1 depends on the cross-section of the specimen and the axial gage length ℓ . To have a representation of material behavior that is independent of specimen size and variables introduced by the experimental setup, we may plot the stress $\sigma = P/A_0$, where A_0 is the undeformed area of the cross-section versus the axial strain $\varepsilon_a = \Delta\ell/\ell$, as shown in Figure 5.1-2. In this way, the test results appear in a form that is not dependent on the specimen dimensions. The slope of the line OA will therefore be a material coefficient that is called the *Young's modulus* (or *modulus of elasticity*). We denote this modulus by E_Y , that is,

$$E_Y = \frac{\sigma}{\varepsilon_a}. \quad (5.1.1)$$

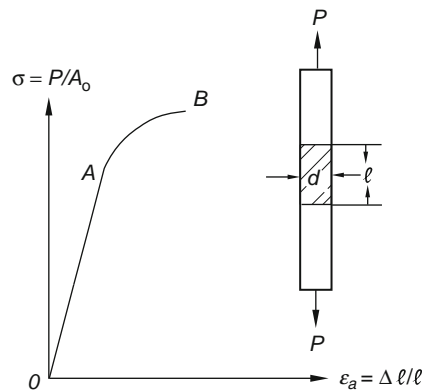

FIGURE 5.1-2

The numerical value of E_Y for steel is around 207 GPa ($30 \times 10^6 \text{ psi}$). This means that for a steel bar of cross-sectional area 32.3 cm^2 (5 in.^2) that carries a load of $667,000 \text{ N}$ ($150,000 \text{ lbs}$), the axial strain is

$$\varepsilon_a = \frac{667000/(32.3 \times 10^{-4})}{207 \times 10^9} \approx 10^{-3}.$$

As expected, the strains in the linear elastic range of metals are quite small, and we can, therefore, use the infinitesimal strain theory to describe the deformation of metals.

In the tension test, we can also measure change in the lateral dimension. If the bar is of circular cross-section with an initial diameter d , it will remain, for certain idealized metal, circular, decreasing in diameter as the tensile load is increased. Letting ε_d be the lateral strain (equal to $\Delta d/d$), we find that the ratio $-\varepsilon_d/\varepsilon_a$ is a constant if the strains are small. We call this constant *Poisson's ratio* and denote it by ν . A typical value of ν for steel is 0.3.

So far we have only been considering a single specimen out of the block of material. It is conceivable that the modulus of elasticity E_Y as well as Poisson's ratio ν may depend on the orientation of the specimen relative to the block. In this case, the material is said to be *anisotropic* with respect to its elastic properties. Anisotropic properties are usually exhibited by materials with a definite internal structure, such as wood or a rolled steel plate, or composite materials and many biological tissues. If the specimens, cut at different orientations at a sufficiently small neighborhood, show the same stress-strain diagram, we can conclude that the material is *isotropic* with respect to its elastic properties in that neighborhood.

In addition to a possible dependence on orientation of the elastic properties, we may also find that they may vary from one neighborhood to the other. In this case, we call the material *inhomogeneous*. If there is no change in the test results for specimens at different neighborhoods, we say the material is *homogeneous*.

Previously we stated that the circular cross-section of a bar can remain circular in the tension test. This is true when the material is homogeneous and isotropic with respect to its elastic properties.

Other characteristic tests with an elastic material are also possible. In one case, we may be interested in the change of volume of a block of material under hydrostatic stress σ for which the stress state is

$$T_{ij} = \sigma \delta_{ij}. \quad (5.1.2)$$

In a suitable experiment, we measure the relation between σ , the applied stress, and e , the change in volume per initial volume [also known as *dilatation*; see Eq. (3.10.2)]. For an elastic material, a linear relation exists for small e , and we define the *bulk modulus* k as

$$k = \frac{\sigma}{e}. \quad (5.1.3)$$

A typical value of k for steel is 138 GPa ($20 \times 10^6 \text{ psi}$).

A torsion experiment yields another elastic constant. For example, we may subject a cylindrical steel bar of circular cross-section of radius r to a twisting moment M_t along the cylinder axis. The bar has a length ℓ and will twist by an angle θ upon the application of the moment M_t . A linear relation between the angle of twist θ and the applied moment M_t will be obtained for small θ . We define a *shear modulus* μ as

$$\mu = \frac{M_t \ell}{I_p \theta}, \quad (5.1.4)$$

where $I_p = \pi r^4/2$ (the polar area second moment). A typical value of μ for steel is 76 GPa ($11 \times 10^6 \text{ psi}$).

For an anisotropic elastic solid, the values of these material coefficients (or material constants) depend on the orientation of the specimen prepared from the block of material. Inasmuch as there are infinitely many orientations possible, an important and interesting question is how many coefficients are required to define completely the mechanical behavior of a particular elastic solid. We answer this question in the following section for a linearly elastic solid.

5.2 LINEARLY ELASTIC SOLID

Within certain limits, the experiments cited in Section 5.1 have the following features in common:

1. The relation between the applied loading and a quantity measuring the deformation is linear.
2. The rate of load application does not have an effect.
3. Upon removal of the loading, the deformations disappear completely.
4. The deformations are very small.

Characteristics 1–4 are now used to formulate the constitutive equation of an ideal material, the *linearly elastic* or *Hookean elastic solid*. The constitutive equation relates the stress to relevant quantities of deformation. In this case, deformations are small and the rate of load application has no effect. We therefore can write

$$\mathbf{T} = \mathbf{T}(\mathbf{E}), \tag{5.2.1}$$

where \mathbf{T} is the Cauchy stress tensor and \mathbf{E} is the infinitesimal strain tensor, with $\mathbf{T}(\mathbf{0}) = \mathbf{0}$. If, in addition, the function is to be linear, then we have, in component form,

$$\begin{aligned} T_{11} &= C_{1111}E_{11} + C_{1112}E_{12} + \dots + C_{1133}E_{33}, \\ T_{12} &= C_{1211}E_{11} + C_{1212}E_{12} + \dots + C_{1233}E_{33}, \\ &\dots \dots \dots \\ T_{33} &= C_{3311}E_{11} + C_{3312}E_{12} + \dots + C_{3333}E_{33}. \end{aligned} \tag{5.2.2}$$

The preceding nine equations can be written compactly as

$$T_{ij} = C_{ijkl}E_{kl}. \tag{5.2.3}$$

Since T_{ij} and E_{ij} are components of second-order tensors, from the quotient rule discussed in Section 2.19, we know that C_{ijkl} are components of a fourth-order tensor, here known as the *elasticity tensor*. The values of these components with respect to the primed basis \mathbf{e}'_i and the unprimed basis \mathbf{e}_i are related by the transformation law (see Section 2.19)

$$C'_{ijkl} = Q_{mi}Q_{nj}Q_{rk}Q_{sl}C_{mnr}. \tag{5.2.4}$$

If the body is homogeneous, that is, the mechanical properties are the same for every particle in the body, then C_{ijkl} are independent of position. We shall be concerned only with homogeneous bodies. There are 81 coefficients in Eq. (5.2.2). However, since $E_{ij} = E_{ji}$, we can always combine the sum of the two terms, such as $C_{1112}E_{12} + C_{1121}E_{21}$, into one term, $(C_{1112} + C_{1121})E_{12}$, so that $(C_{1112} + C_{1121})$ becomes *one* independent coefficient. Equivalently, we can simply take $C_{1112} = C_{1121}$. Thus, due to the symmetry of the strain tensor, we have

$$C_{ijkl} = C_{ijlk}. \tag{5.2.5}$$

The preceding equations reduce the number of independent C_{ijkl} from 81 to 54. We shall consider only the case where the stress tensor is symmetric, i.e.,

$$T_{ij} = T_{ji}. \tag{5.2.6}$$

As a consequence,

$$C_{ijkl} = C_{jikl}. \tag{5.2.7}$$

The preceding equations further reduce the number of independent coefficients by 18. Thus, we have, for the general case of a linearly elastic body, a maximum of 36 material coefficients.

Furthermore, we assume that the concept of “elasticity” is associated with the existence of a stored energy function $U(E_{ij})$, also known as the *strain energy function*, which is a positive definite function of the strain components such that

$$T_{ij} = \frac{\partial U}{\partial E_{ij}}. \quad (5.2.8)$$

With such an assumption [the motivation for Eq. (5.2.8) is given in Example 5.2.1], it can be shown (see Example 5.2.2) that

$$C_{ijkl} = C_{klij}. \quad (5.2.9)$$

Equations (5.2.9) reduce the number of elastic coefficients from 36 to 21.

Example 5.2.1

- (a) In the infinitesimal theory of elasticity, both the displacement components and the components of displacement gradient are assumed to be very small. Show that under these assumptions, the rate of deformation tensor \mathbf{D} can be approximated by $D\mathbf{E}/Dt$, where \mathbf{E} is the infinitesimal strain tensor.
- (b) Show that if T_{ij} is given the $T_{ij} = C_{ijkl}E_{kl}$ [Eq. (5.2.3)], then the rate of work done by the stress components to change the volume and shape of a material volume is given by

$$P_s = \frac{DU}{Dt}, \quad (5.2.10)$$

where U is the strain energy function defined by Eq. (5.2.8).

Solution

- (a) From $2E_{ij} = (\partial u_i/\partial X_j + \partial u_j/\partial X_i)$, we have

$$2 \frac{DE_{ij}}{Dt} = \frac{\partial}{\partial X_j} \frac{Du_i}{Dt} + \frac{\partial}{\partial X_i} \frac{Du_j}{Dt} = \frac{\partial v_i}{\partial X_j} + \frac{\partial v_j}{\partial X_i}. \quad (5.2.11)$$

Since $x_i = x_i(X_1, X_2, X_3, t)$, we can obtain

$$\frac{\partial v_i}{\partial X_j} + \frac{\partial v_j}{\partial X_i} = \frac{\partial v_i}{\partial x_m} \frac{\partial x_m}{\partial X_j} + \frac{\partial v_j}{\partial x_m} \frac{\partial x_m}{\partial X_i}. \quad (5.2.12)$$

Now, from $x_m = X_m + u_m$, where u_m is the infinitesimal displacement components, we have

$$\frac{\partial x_m}{\partial X_i} = \delta_{mi} + \frac{\partial u_m}{\partial X_i} \quad \text{and} \quad \frac{\partial x_m}{\partial X_j} = \delta_{mj} + \frac{\partial u_m}{\partial X_j}. \quad (5.2.13)$$

Thus, neglecting small quantities of higher order, we have

$$2 \frac{DE_{ij}}{Dt} = \frac{\partial v_i}{\partial X_j} + \frac{\partial v_j}{\partial X_i} = \frac{\partial v_i}{\partial x_m} \delta_{mj} + \frac{\partial v_j}{\partial x_m} \delta_{mi} = \frac{\partial v_i}{\partial x_j} + \frac{\partial v_j}{\partial x_i} \equiv 2D_{ij}. \quad (5.2.14)$$

That is,

$$\frac{DE_{ij}}{Dt} = D_{ij}. \quad (5.2.15)$$

- (b) In Section 4.12, we derived the formula for computing the stress power, that is, the rate of work done by the stress components to change the volume and shape of a material volume as [see Eq. (4.12.4)]

$$P_s = T_{ij} D_{ij}. \quad (5.2.16)$$

Using Eq. (5.2.15), we have

$$P_s = T_{ij} \frac{DE_{ij}}{Dt}. \quad (5.2.17)$$

Now, if $T_{ij} = \partial U / \partial E_{ij}$ [Eq. (5.2.8)], then

$$P_s = \frac{\partial U}{\partial E_{ij}} \frac{DE_{ij}}{Dt} = \frac{\partial U}{\partial E_{ij}} \left(\frac{\partial E_{ij}}{\partial t} \right)_{X_j = \text{fixed}} = \left(\frac{\partial U}{\partial t} \right)_{X_j = \text{fixed}} = \frac{DU}{Dt}. \quad (5.2.18)$$

That is, with the assumption given by Eq. (5.2.8), the rate at which the strain energy increases is completely determined by P_s , the rate at which the stress components are doing work to change the volume and shape. Thus, if P_s is zero, then the strain energy remains a constant (i.e., stored). This result provides the motivation for assuming the existence of a positive definite energy function* through Eq. (5.2.8).

Example 5.2.2

Show that if $T_{ij} = \partial U / \partial E_{ij}$ for a linearly elastic solid, (a) the components of the elastic tensor satisfies the condition

$$C_{ijkl} = C_{klij}, \quad (5.2.19)$$

and (b) the strain energy function U is given by

$$U = \frac{1}{2} T_{ij} E_{ij} = \frac{1}{2} C_{ijkl} E_{ij} E_{kl}. \quad (5.2.20)$$

Solution

- (a) For a linearly elastic solid, $T_{ij} = C_{ijkl} E_{kl}$, therefore,

$$\frac{\partial T_{ij}}{\partial E_{rs}} = C_{ijrs}. \quad (5.2.21)$$

Thus, from Eq. (5.2.8), i.e., $T_{ij} = \partial U / \partial E_{ij}$, we have

$$C_{ijrs} = \frac{\partial^2 U}{\partial E_{rs} \partial E_{ij}} = \frac{\partial^2 U}{\partial E_{ij} \partial E_{rs}} = C_{rsij}, \quad (5.2.22)$$

therefore,

$$C_{ijkl} = C_{klij}. \quad (5.2.23)$$

*In this chapter we define the concept of elasticity without considering any thermodynamic effects. In thermo-elastic theory, the strain energy function is identified with the internal energy function in isothermal motions and with the Helmholtz free energy function in isentropic motions.

(b) From $T_{ij} = \partial U / \partial E_{ij}$, we have

$$T_{ij} dE_{ij} = \frac{\partial U}{\partial E_{ij}} dE_{ij} = dU, \quad (5.2.24)$$

i.e.,

$$dU = C_{ijkl} E_{kl} dE_{ij}. \quad (5.2.25)$$

Changing the dummy indices, we obtain

$$dU = C_{klij} E_{ij} dE_{kl}. \quad (5.2.26)$$

But $C_{klij} = C_{ijkl}$; therefore,

$$dU = C_{ijkl} E_{ij} dE_{kl}. \quad (5.2.27)$$

Adding Eqs. (5.2.25) and (5.2.27), we obtain

$$2dU = C_{ijkl} (E_{kl} dE_{ij} + E_{ij} dE_{kl}) = C_{ijkl} d(E_{ij} E_{kl}),$$

from which we obtain

$$U = \frac{1}{2} C_{ijkl} E_{ij} E_{kl}. \quad (5.2.28)$$

In the following, we first show that if the material is isotropic, then the number of independent coefficients reduces to only 2. Later, in Part B, the constitutive equations for anisotropic elastic solid involving 13 coefficients (monoclinic elastic solid), nine coefficients (orthotropic elastic solid), and five coefficients (transversely isotropic solid) will be discussed.

PART A: ISOTROPIC LINEARLY ELASTIC SOLID

5.3 ISOTROPIC LINEARLY ELASTIC SOLID

A material is said to be *isotropic* if its mechanical properties can be described without reference to directions. When this is not true, the material is said to be *anisotropic*. Many structural metals such as steel and aluminum can be regarded as isotropic without appreciable error.

We had, for a linearly elastic solid, with respect to the \mathbf{e}_i basis,

$$T_{ij} = C_{ijkl} E_{kl}, \quad (5.3.1)$$

and with respect to the \mathbf{e}'_i basis,

$$T'_{ij} = C'_{ijkl} E'_{kl}. \quad (5.3.2)$$

If the material is isotropic, then the components of the elasticity tensor must remain the same, regardless of how the rectangular basis is rotated and reflected. That is,

$$C'_{ijkl} = C_{ijkl}, \quad (5.3.3)$$

under all orthogonal transformations of basis. A tensor having the same components with respect to every orthonormal basis is known as an *isotropic tensor*. For example, the identity tensor \mathbf{I} is obviously an isotropic tensor since its components δ_{ij} are the same for any Cartesian basis. Indeed, it can be proved (see Prob. 5.2) that except for a scalar multiple, the identity tensor δ_{ij} is the only isotropic second-order tensor. From this isotropic second-order tensor δ_{ij} we can form the following three isotropic fourth-order tensors (see product rules in Section 2.19):

$$A_{ijkl} = \delta_{ij}\delta_{kl}, \quad B_{ijkl} = \delta_{ik}\delta_{jl} \quad \text{and} \quad H_{ijkl} = \delta_{il}\delta_{jk}. \quad (5.3.4)$$

In Part B of this chapter, we shall give the detail reductions of the general C_{ijkl} to the isotropic C_{ijkl} . Here, as a shortcut to the isotropic case, we shall express the elasticity tensor C_{ijkl} in terms of A_{ijkl} , B_{ijkl} , and H_{ijkl} . That is,

$$C_{ijkl} = \lambda A_{ijkl} + \alpha B_{ijkl} + \beta H_{ijkl}, \quad (5.3.5)$$

where λ , α and β are constants. Using Eqs. (5.3.4) and (5.3.5), Eq. (5.3.1) becomes

$$T_{ij} = C_{ijkl}E_{kl} = \lambda\delta_{ij}\delta_{kl}E_{kl} + \alpha\delta_{ik}\delta_{jl}E_{kl} + \beta\delta_{il}\delta_{jk}E_{kl}. \quad (5.3.6)$$

Thus,

$$T_{ij} = \lambda E_{kk}\delta_{ij} + (\alpha + \beta)E_{ij}, \quad (5.3.7)$$

or, denoting $(\alpha + \beta)$ by 2μ , we have

$$T_{ij} = \lambda e\delta_{ij} + 2\mu E_{ij}, \quad (5.3.8)$$

where

$$e \equiv E_{kk}, \quad (5.3.9)$$

denotes the dilatation. In direct notation, Eq. (5.3.8) reads

$$\mathbf{T} = \lambda e\mathbf{I} + 2\mu\mathbf{E}. \quad (5.3.10)$$

In long form, Eq. (5.3.8) or (5.3.10) reads

$$T_{11} = \lambda(E_{11} + E_{22} + E_{33}) + 2\mu E_{11}, \quad (5.3.11)$$

$$T_{22} = \lambda(E_{11} + E_{22} + E_{33}) + 2\mu E_{22}, \quad (5.3.12)$$

$$T_{33} = \lambda(E_{11} + E_{22} + E_{33}) + 2\mu E_{33}, \quad (5.3.13)$$

$$T_{12} = 2\mu E_{12}, \quad (5.3.14)$$

$$T_{13} = 2\mu E_{13}, \quad (5.3.15)$$

$$T_{23} = 2\mu E_{23}. \quad (5.3.16)$$

Equation (5.3.8) or (5.3.10) are the constitutive equations for an isotropic linearly elastic solid. The two material constants λ and μ are known as *Lamé's coefficients* or *Lamé's constants*. Since E_{ij} are dimensionless, λ and μ are of the same dimension as the stress tensor, force per unit area. For a given real material, the values of Lamé's constants are to be determined from suitable experiments. We shall have more to say about this later.

Example 5.3.1

(a) For an isotropic Hookean material, show that the principal directions of stress and strain coincide and (b) find a relation between the principal values of stress and strain.

Solution

(a) Let \mathbf{n}_1 be an eigenvector of the strain tensor \mathbf{E} (i.e., $\mathbf{E}\mathbf{n}_1 = E_1\mathbf{n}_1$). Then, by Hooke's law, Eq. (5.3.10), we have

$$\mathbf{T}\mathbf{n}_1 = 2\mu\mathbf{E}\mathbf{n}_1 + \lambda e\mathbf{n}_1 = (2\mu E_1 + \lambda e)\mathbf{n}_1.$$

Therefore, \mathbf{n}_1 is also an eigenvector of the tensor \mathbf{T} .

(b) Let E_1, E_2, E_3 be the eigenvalues of \mathbf{E} ; then $e = E_1 + E_2 + E_3$ and Eqs. (5.3.11), (5.3.12), and (5.3.13) give

$$\begin{aligned} T_1 &= 2\mu E_1 + \lambda(E_1 + E_2 + E_3), \\ T_2 &= 2\mu E_2 + \lambda(E_1 + E_2 + E_3), \\ T_3 &= 2\mu E_3 + \lambda(E_1 + E_2 + E_3). \end{aligned}$$

Example 5.3.2

For an isotropic material, (a) find a relation between the first invariants of stress and strain, and (b) use the result of part (a) to invert Hooke's law so that strain is a function of stress.

Solution

(a) By contracting the indices in Eq. (5.3.8), [i.e., adding Eqs. (5.3.11), (5.3.12), and (5.3.13)], we obtain

$$T_{kk} = (2\mu + 3\lambda)E_{kk} = (2\mu + 3\lambda)e. \quad (5.3.17)$$

(b) With

$$e = \frac{T_{kk}}{(2\mu + 3\lambda)}, \quad (5.3.18)$$

Eq. (5.3.10) can be inverted to be

$$\mathbf{E} = \frac{1}{2\mu}\mathbf{T} - \frac{\lambda T_{kk}}{2\mu(2\mu + 3\lambda)}\mathbf{I}. \quad (5.3.19)$$

5.4 YOUNG'S MODULUS, POISSON'S RATIO, SHEAR MODULUS, AND BULK MODULUS

Equation (5.3.8) expresses the stress components in terms of the strain components. This equation can be inverted, as was done in Example 5.3.2, to give

$$E_{ij} = \frac{1}{2\mu} \left[T_{ij} - \frac{\lambda}{3\lambda + 2\mu} T_{kk} \delta_{ij} \right]. \quad (5.4.1)$$

We also have, from Eq. (5.3.18),

$$e = \left(\frac{1}{3\lambda + 2\mu} \right) T_{kk}. \quad (5.4.2)$$

If the state of stress is such that only one normal stress component is not zero, we call it a *uniaxial stress state*. The uniaxial stress state is a good approximation of the actual state of stress in the cylindrical bar used in the tensile test described in Section 5.1. If we take the axial direction to be in the \mathbf{e}_1 direction, the only nonzero stress component is T_{11} ; then Eq. (5.4.1) gives

$$E_{11} = \frac{1}{2\mu} \left[T_{11} - \frac{\lambda}{3\lambda + 2\mu} T_{11} \right] = \frac{\lambda + \mu}{\mu(3\lambda + 2\mu)} T_{11}, \quad (5.4.3)$$

$$E_{33} = E_{22} = \frac{1}{2\mu} \left[0 - \frac{\lambda}{3\lambda + 2\mu} T_{11} \right] = -\frac{\lambda}{2\mu(3\lambda + 2\mu)} T_{11} = -\frac{\lambda}{2(\lambda + \mu)} E_{11}, \quad (5.4.4)$$

and

$$E_{12} = E_{13} = E_{23} = 0. \quad (5.4.5)$$

The ratio T_{11}/E_{11} , corresponding to the ratio σ/ε_a of the tensile test described in Section 5.1, is *Young's modulus* or the *modulus of elasticity* E_Y . Thus, from Eq. (5.4.3),

$$E_Y = \frac{\mu(3\lambda + 2\mu)}{\lambda + \mu}. \quad (5.4.6)$$

The ratio $-E_{22}/E_{11}$ and $-E_{33}/E_{11}$ corresponding to the ratio $-\varepsilon_d/\varepsilon_a$ of the same tensile test is *Poisson's ratio*, denoted by ν . Thus, from Eq. (5.4.4),

$$\nu = \frac{\lambda}{2(\lambda + \mu)}. \quad (5.4.7)$$

Using Eqs. (5.4.6) and (5.4.7), we can write Eq. (5.4.1) in the conventional engineering form

$$E_{11} = \frac{1}{E_Y} [T_{11} - \nu(T_{22} + T_{33})], \quad (5.4.8)$$

$$E_{22} = \frac{1}{E_Y} [T_{22} - \nu(T_{33} + T_{11})], \quad (5.4.9)$$

$$E_{33} = \frac{1}{E_Y} [T_{33} - \nu(T_{11} + T_{22})], \quad (5.4.10)$$

$$E_{12} = \frac{1}{2\mu} T_{12}, \quad (5.4.11)$$

$$E_{13} = \frac{1}{2\mu} T_{13}, \quad (5.4.12)$$

$$E_{23} = \frac{1}{2\mu} T_{23}. \quad (5.4.13)$$

Even though there are three material constants in Eqs. (5.4.8) to (5.4.13), it is important to remember that only two of them are independent for an isotropic material. In fact, by eliminating λ from Eqs. (5.4.6) and (5.4.7), we have the important relation:

$$\mu = \frac{E_Y}{2(1+\nu)}. \quad (5.4.14)$$

Using this relation, we can also write Eq. (5.4.1) as

$$E_{ij} = \frac{1}{E_Y} [(1+\nu)T_{ij} - \nu T_{kk}\delta_{ij}]. \quad (5.4.15)$$

If the state of stress is such that only one pair of shear stresses is not zero, it is called a *simple shear stress state*. The state of stress may be described by $T_{12} = T_{21} = \tau$, and Eq. (5.4.11) gives

$$E_{12} = E_{21} = \frac{\tau}{2\mu}. \quad (5.4.16)$$

Defining the *shear modulus* G as the ratio of the shearing stress τ in *simple shear* to the small decrease in angle between elements that are initially in the \mathbf{e}_1 and \mathbf{e}_2 directions, we have

$$\frac{\tau}{2E_{12}} = G. \quad (5.4.17)$$

Comparing Eq. (5.4.17) with Eq. (5.4.16), we see that the Lamé's constant μ is also the *shear modulus* G .

A third stress state, called the *hydrostatic state of stress*, is defined by the stress tensor $\mathbf{T} = \sigma\mathbf{I}$. In this case, Eq. (5.4.2) gives

$$e = \frac{3\sigma}{2\mu + 3\lambda}. \quad (5.4.18)$$

As mentioned in Section 5.1, the *bulk modulus* k is defined as the ratio of the hydrostatic normal stress σ to the unit volume change. We have

$$k = \frac{\sigma}{e} = \frac{2\mu + 3\lambda}{3} = \lambda + \frac{2}{3}\mu. \quad (5.4.19)$$

From Eqs. (5.4.6), (5.4.7), (5.4.14), and (5.4.19), we see that the Lamé's constants, Young's modulus, the shear modulus, Poisson's ratio, and the bulk modulus are all interrelated. Only two of them are independent for an isotropic, linearly elastic material. Table 5.1 expresses the various elastic constants in terms of two basic pairs. Table 5.2 gives some typical values for some common materials.

Example 5.4.1

A material is called *incompressible* if there is no change of volume under any and all states of stresses. Show that for an incompressible isotropic linearly elastic solid with finite Young's modulus E_Y , (a) Poisson's ratio $\nu = 1/2$, (b) the shear modulus $\mu = E_Y/3$, and (c) $k \rightarrow \infty$, $\lambda \rightarrow \infty$ and $k - \lambda = 2\mu/3$.

Solution

(a) From Eq. (5.4.15),

$$E_{ii} = \frac{1}{E_Y} [(1+\nu)T_{ii} - 3\nu T_{kk}] = \frac{1}{E_Y} (1-2\nu)T_{ii}. \quad (5.4.20)$$

Now, E_{ii} is the change of volume per unit volume (the dilatation) and T_{ii} is the sum of the normal stresses. Thus, if the material is incompressible, then $\nu = 1/2$.

(b) $\nu = \frac{E_Y}{2\mu} - 1$, therefore, $\frac{E_Y}{2\mu} = 1 + \frac{1}{2} = \frac{3}{2}$, from which $\mu = \frac{E_Y}{3}$.

(c) For the hydrostatic state of stress $T_{ij} = \sigma\delta_{ij}$, $T_{ii} = 3\sigma$, Eq. (5.4.20) becomes

$$\frac{E_Y}{3(1-2\nu)} = \frac{\sigma}{e} \equiv k. \tag{5.4.21}$$

For an incompressible solid, $\nu \rightarrow 1/2$; thus, $k \rightarrow \infty$. Now, $k = \lambda + \frac{2\mu}{3}$; therefore, $\lambda \rightarrow \infty$. But $k - \lambda = \frac{2\mu}{3}$, which is a finite quantity.

Table 5.1 Conversion of Constants for an Isotropic Elastic Solid

	λ	μ	E_Y	ν	k
λ, μ	λ	μ	$\frac{\mu(3\lambda + 2\mu)}{\lambda + \mu}$	$\frac{\lambda}{2(\lambda + \mu)}$	$\lambda + \frac{2}{3}\mu$
λ, ν	λ	$\frac{\lambda(1-2\nu)}{2\nu}$	$\frac{\lambda(1+\nu)(1-2\nu)}{\nu}$	ν	$\frac{\lambda(1+\nu)}{3\nu}$
λ, k	λ	$\frac{3(k-\lambda)}{2}$	$\frac{9k(k-\lambda)}{(3k-\lambda)}$	$\frac{\lambda}{(3k-\lambda)}$	k
μ, E_Y	$\frac{\mu(E_Y - 2\mu)}{3\mu - E_Y}$	μ	E_Y	$\frac{E_Y}{2\mu} - 1$	$\frac{\mu E_Y}{3(3\mu - E_Y)}$
μ, ν	$\frac{2\mu\nu}{(1-2\nu)}$	μ	$2\mu(1+\nu)$	ν	$\frac{2\mu(1+\nu)}{3(1-2\nu)}$
μ, k	$k - \frac{2}{3}\mu$	μ	$\frac{9k\mu}{(3k+\mu)}$	$\frac{3k-2\mu}{6k+2\mu}$	k
E_Y, ν	$\frac{\nu E_Y}{(1+\nu)(1-2\nu)}$	$\frac{E_Y}{2(1+\nu)}$	E_Y	ν	$\frac{E_Y}{3(1-2\nu)}$
E_Y, k	$\frac{3(kE_Y - 3k^2)}{(E_Y - 9k)}$	$\frac{3kE_Y}{(9k - E_Y)}$	E_Y	$\nu = \frac{(3k - E_Y)}{6k}$	k
k, ν	$\frac{3k\nu}{(1+\nu)}$	$\frac{3k(1-2\nu)}{2(1+\nu)}$	$3k(1-2\nu)$	ν	k
λ, E_Y	λ	$\mu(\lambda, E_Y)^*$	E_Y	$\frac{E_Y}{2\mu(\lambda, E_Y)} - 1$	$\frac{\mu(\lambda, E_Y)E_Y}{3[3\mu(\lambda, E_Y) - E_Y]}$

$$*\mu(\lambda, E_Y) = \left\{ -(3\lambda - E_Y) + \sqrt{(3\lambda - E_Y)^2 + 8E_Y\lambda} \right\} / 4.$$

Note: (1) As $\nu \rightarrow 1/2$, $k \rightarrow \infty$, $\lambda \rightarrow \infty$, $\mu \rightarrow E_Y/3$, (2) it is generally accepted that compressive hydrostatic stress state will not lead to an increase in volume, therefore, $\nu < 1/2$, (3) for isotropic materials whose transverse strain is negative when subjected to the action of simple extension, the Poisson's ratio is: $0 \leq \nu < 1/2$ and (4) for the so-called auxetic materials, the transverse strain is positive while under simple extension, the Poisson's ratio is negative. Thus, for an isotropic material, in general, $-1 < \nu < 1/2$. For a discussion of the lower limit of -1 , see Section 5.52 in Part B of this Chapter.

Table 5.2 Elastic Constants for Isotropic Solids at Room Temperature[†]

Material	Composition	Modulus of Elasticity, E_Y GPa (10^6 psi)	Poisson's ratio, ν	Shear Modulus, μ GPa (10^6 psi)	Lamè's constant, λ GPa (10^6 psi)	Bulk Modulus k GPa (10^6 psi)
Aluminum	Pure and alloy	68.2–78.5 (9.9–11.4)	0.32–0.34	25.5–26.53 (3.7–3.85)	46.2–62.7 (6.7–9.1)	63.4–80.6 (9.2–11.7)
Brass	60–70% Cu, 40–30% Zn	99.9–109.6 (14.5–15.9)	0.33–0.36	36.5–41.3 (5.3–6.0)	73.0–103.4 (10.6–15.0)	97.1–130.9 (14.1–19.0)
Copper		117–124 (17–18)	0.33–0.36	40.0–46.2 (5.8–6.7)	85.4–130.9 (12.4–19.0)	112.3–148.1 (16.3–21.5)
Cast iron	2.7–3.6% C	90–145 (13–21)	0.21–0.30	35.8–56.5 (5.2–8.2)	26.9–83.4 (3.9–12.1)	51.0–121.3 (7.4–17.6)
Steel	Carbon and low alloy	193–220 (28–32)	0.26–0.29	75.8–82.0 (11.0–11.9)	82.7–117.8 (12.0–17.1)	133.0–172.3 (19.3–25.0)
Stainless Steel	18% Cr, 8% Ni	193–207 (28–30)	0.3	73.0 (10.6)	111.6–119.2 (16.2–17.3)	160.5–168.1 (23.2–24.4)
Titanium	Pure and alloy	106.1–114.4 (15.4–16.6)	0.34	41.3 (6.0)	84.1–90.9 (12.2–13.2)	111.6–118.5 (16.2–17.2)
Glass	Various	49.6–79.2 (7.2–11.5)	0.21–0.27	26.2–32.4 (3.8–4.7)	15.2–36.5 (2.2–5.3)	32.4–57.9 (4.7–8.4)
Rubber		0.00076– 0.00413 (0.00011– 0.00060)	0.50	0.00028– 0.00138 (0.00004– 0.00020)	∞^*	∞^*

* As ν approaches 0.5, the ratio k/E_Y and $\lambda/\mu \rightarrow \infty$. The actual value of k and λ for some rubbers may be close to the values of steel.
[†] Partly from "an Introduction to the Mechanics of Solids," S.H. Crandall and N.C Dahl (Eds.), McGraw-Hill, 1959.

5.5 EQUATIONS OF THE INFINITESIMAL THEORY OF ELASTICITY

In Section 4.7, we derived the Cauchy's equation of motion [see Eq. (4.7.5)], to be satisfied by the stress field in any continuum:

$$\rho a_i = \rho B_i + \frac{\partial T_{ij}}{\partial x_j}, \quad (5.5.1)$$

where ρ is the density, a_i the acceleration component, ρB_i the component of body force per unit volume, and T_{ij} the Cauchy stress components. All terms in the equation are quantities associated with a particle that is currently at the position (x_1, x_2, x_3) .

We shall consider only the case of small motions, that is, motions such that every particle is always in a small neighborhood of the natural state. More specifically, if X_i denotes the position in the natural state of a typical particle, we assume that

$$x_i \approx X_i, \quad (5.5.2)$$

and that the magnitude of the components of the displacement gradient $\partial u_i / \partial x_j$ is also very small. From

$$x_1 = X_1 + u_1, \quad x_2 = X_2 + u_2, \quad x_3 = X_3 + u_3, \quad (5.5.3)$$

we have the velocity components related to the displacement components by

$$v_i = \frac{Dx_i}{Dt} = \left(\frac{\partial u_i}{\partial t} \right)_{x_i\text{-fixed}} + v_1 \frac{\partial u_i}{\partial x_1} + v_2 \frac{\partial u_i}{\partial x_2} + v_3 \frac{\partial u_i}{\partial x_3}, \quad (5.5.4)$$

where v_i are the small velocity components associated with the small displacement components. Neglecting the small quantities of higher order, we obtain the velocity components as

$$v_i = \left(\frac{\partial u_i}{\partial t} \right)_{x_i\text{-fixed}}, \quad (5.5.5)$$

and the acceleration component as

$$a_i = \left(\frac{\partial^2 u_i}{\partial t^2} \right)_{x_i\text{-fixed}}. \quad (5.5.6)$$

Furthermore, the differential volume dV is related to the initial volume dV_o by the equation (see Section 3.10)

$$dV = (1 + E_{kk})dV_o, \quad (5.5.7)$$

therefore, the densities are related by

$$\rho = (1 + E_{kk})^{-1} \rho_o \approx (1 - E_{kk}) \rho_o, \quad (5.5.8)$$

where we have used the binomial theorem. Again, neglecting small quantities of higher order, we have

$$\rho a_i = \rho_o \left(\frac{\partial^2 u_i}{\partial t^2} \right)_{x_i\text{-fixed}}. \quad (5.5.9)$$

Thus, Eq. (5.5.1) becomes

$$\rho_o \frac{\partial^2 u_i}{\partial t^2} = \rho_o B_i + \frac{\partial T_{ij}}{\partial x_j}. \quad (5.5.10)$$

In Eq. (5.5.10), all displacement components are regarded as functions of the spatial coordinates x_i , and the equations simply state that for infinitesimal motions, there is no need to make the distinction between the spatial coordinates x_i and the material coordinates X_i . *In the following sections in Parts A and B of this chapter, all displacement components will be expressed as functions of the spatial coordinates.*

A displacement field $u_i(x_1, x_2, x_3, t)$ is said to describe a *possible motion* in an elastic medium with small deformation if it satisfies Eq. (5.5.10). When a displacement field $u_i(x_1, x_2, x_3, t)$ is given, to make sure that it is a possible motion, we can first compute the strain field E_{ij} from Eq. (3.7.16), i.e.,

$$E_{ij} = \frac{1}{2} \left(\frac{\partial u_i}{\partial x_j} + \frac{\partial u_j}{\partial x_i} \right), \quad (5.5.11)$$

and then the corresponding elastic stress field T_{ij} from Eq. (5.3.8), i.e.,

$$T_{ij} = \lambda e \delta_{ij} + 2\mu E_{ij}. \quad (5.5.12)$$

Then the substitution of u_i and T_{ij} into Eq. (5.5.10) will verify whether or not the given motion is possible. Alternatively, one can substitute directly the displacement field into the Navier's equations, to be derived in the next section for the same purpose. If the motion is found to be possible, the surface tractions (i.e., stress vectors on the surface of the body) on the boundary of the body needed to maintain the motion are given by Eq. (4.9.1), i.e.,

$$t_i = T_{ij} n_j. \quad (5.5.13)$$

On the other hand, if the boundary conditions are prescribed, then, in order that u_i be the solution to the problem, it must meet the prescribed conditions on the boundary, whether they are displacement conditions or surface traction conditions.

5.6 NAVIER EQUATIONS OF MOTION FOR ELASTIC MEDIUM

In this section, we combine Eqs. (5.5.10), (5.5.11), and (5.5.12) to obtain the equations of motion in terms of the displacement components only. These equations are known as *Navier's equations* of motion. First, from Eqs. (5.5.11) and (5.5.12), we have

$$T_{ij} = \lambda e \delta_{ij} + 2\mu E_{ij} = \lambda e \delta_{ij} + \mu \left(\frac{\partial u_i}{\partial x_j} + \frac{\partial u_j}{\partial x_i} \right). \quad (5.6.1)$$

Thus,

$$\frac{\partial T_{ij}}{\partial x_j} = \lambda \frac{\partial e}{\partial x_j} \delta_{ij} + \mu \left(\frac{\partial^2 u_i}{\partial x_j \partial x_j} + \frac{\partial u_j}{\partial x_j \partial x_i} \right). \quad (5.6.2)$$

Now,

$$\frac{\partial e}{\partial x_j} \delta_{ij} = \frac{\partial e}{\partial x_i} \quad \text{and} \quad \frac{\partial u_j}{\partial x_j \partial x_i} = \frac{\partial}{\partial x_i} \left(\frac{\partial u_j}{\partial x_j} \right) = \frac{\partial e}{\partial x_i}, \quad (5.6.3)$$

therefore, the equation of motion, Eq. (5.5.10), becomes

$$\rho_o \frac{\partial^2 u_i}{\partial t^2} = \rho_o B_i + (\lambda + \mu) \frac{\partial e}{\partial x_i} + \mu \frac{\partial^2 u_i}{\partial x_j \partial x_j}. \quad (5.6.4)$$

In long form, Eq. (5.6.4) reads

$$\rho_o \frac{\partial^2 u_1}{\partial t^2} = \rho_o B_1 + (\lambda + \mu) \frac{\partial e}{\partial x_1} + \mu \left(\frac{\partial^2}{\partial x_1^2} + \frac{\partial^2}{\partial x_2^2} + \frac{\partial^2}{\partial x_3^2} \right) u_1, \quad (5.6.5)$$

$$\rho_o \frac{\partial^2 u_2}{\partial t^2} = \rho_o B_2 + (\lambda + \mu) \frac{\partial e}{\partial x_2} + \mu \left(\frac{\partial^2}{\partial x_1^2} + \frac{\partial^2}{\partial x_2^2} + \frac{\partial^2}{\partial x_3^2} \right) u_2, \quad (5.6.6)$$

$$\rho_o \frac{\partial^2 u_3}{\partial t^2} = \rho_o B_3 + (\lambda + \mu) \frac{\partial e}{\partial x_3} + \mu \left(\frac{\partial^2}{\partial x_1^2} + \frac{\partial^2}{\partial x_2^2} + \frac{\partial^2}{\partial x_3^2} \right) u_3, \quad (5.6.7)$$

where

$$e = \frac{\partial u_i}{\partial x_i} = \frac{\partial u_1}{\partial x_1} + \frac{\partial u_2}{\partial x_2} + \frac{\partial u_3}{\partial x_3}. \quad (5.6.8)$$

In invariant form, the Navier equations of motion take the form

$$\rho_o \frac{\partial^2 \mathbf{u}}{\partial t^2} = \rho_o \mathbf{B} + (\lambda + \mu) \nabla e + \mu \nabla^2 \mathbf{u}, \quad (5.6.9)$$

where

$$e = \operatorname{div} \mathbf{u}. \quad (5.6.10)$$

Example 5.6.1

Given the displacement field $u_1 = u_1(x_1, t)$, $u_2 = u_3 = 0$, obtain the equation that must be satisfied by u_1 so that it is a possible motion for an isotropic linearly elastic solid in the absence of body forces.

Solution

From the Navier equation (5.6.5), we have

$$\rho_o \frac{\partial^2 u_1}{\partial t^2} = (\lambda + \mu) \frac{\partial e}{\partial x_1} + \mu \frac{\partial^2 u_1}{\partial x_1^2} = (\lambda + \mu) \frac{\partial}{\partial x_1} \left(\frac{\partial u_1}{\partial x_1} \right) + \mu \frac{\partial^2 u_1}{\partial x_1^2} = (\lambda + 2\mu) \frac{\partial^2 u_1}{\partial x_1^2}. \quad (5.6.11)$$

Thus,

$$\frac{\partial^2 u_1}{\partial t^2} = c_L^2 \frac{\partial^2 u_1}{\partial x_1^2}, \quad (5.6.12)$$

where

$$c_L = \sqrt{\frac{\lambda + 2\mu}{\rho_o}}. \quad (5.6.13)$$

Equation (5.6.12) is known as the *simple wave equation*.

5.7 NAVIER EQUATIONS IN CYLINDRICAL AND SPHERICAL COORDINATES

Using the expressions for \mathbf{E} and $\nabla^2 \mathbf{u}$ derived for cylindrical and spherical coordinates in Section 3.7 and in Part D of Chapter 2, we can obtain Hooke's law and Navier's equations in these two coordinates as follows:

Cylindrical coordinates. With (u_r, u_θ, u_z) denoting the displacements in (r, θ, z) directions, Hooke's laws are

$$T_{rr} = \lambda e + 2\mu \frac{\partial u_r}{\partial r}, \quad T_{\theta\theta} = \lambda e + 2\mu \left(\frac{1}{r} \frac{\partial u_\theta}{\partial \theta} + \frac{u_r}{r} \right), \quad T_{zz} = \lambda e + 2\mu \frac{\partial u_z}{\partial z}, \quad (5.7.1)$$

$$T_{r\theta} = \mu \left(\frac{1}{r} \frac{\partial u_r}{\partial \theta} + \frac{\partial u_\theta}{\partial r} - \frac{u_\theta}{r} \right), \quad T_{\theta z} = \mu \left(\frac{\partial u_\theta}{\partial z} + \frac{1}{r} \frac{\partial u_z}{\partial \theta} \right), \quad T_{zr} = \mu \left(\frac{\partial u_r}{\partial z} + \frac{\partial u_z}{\partial r} \right), \quad (5.7.2)$$

where

$$e = \frac{\partial u_r}{\partial r} + \frac{u_r}{r} + \frac{1}{r} \frac{\partial u_\theta}{\partial \theta} + \frac{\partial u_z}{\partial z}, \quad (5.7.3)$$

and Navier's equations of motion are

$$\rho_o \frac{\partial^2 u_r}{\partial t^2} = \rho_o B_r + (\lambda + \mu) \frac{\partial e}{\partial r} + \mu \left[\frac{\partial^2 u_r}{\partial r^2} + \frac{1}{r^2} \frac{\partial^2 u_r}{\partial \theta^2} + \frac{\partial^2 u_r}{\partial z^2} + \frac{1}{r} \frac{\partial u_r}{\partial r} - \frac{2}{r^2} \frac{\partial u_\theta}{\partial \theta} - \frac{u_r}{r^2} \right], \quad (5.7.4)$$

$$\rho_o \frac{\partial^2 u_\theta}{\partial t^2} = \rho_o B_\theta + \frac{(\lambda + \mu)}{r} \frac{\partial e}{\partial \theta} + \mu \left[\frac{\partial^2 u_\theta}{\partial r^2} + \frac{1}{r^2} \frac{\partial^2 u_\theta}{\partial \theta^2} + \frac{\partial^2 u_\theta}{\partial z^2} + \frac{1}{r} \frac{\partial u_\theta}{\partial r} + \frac{2}{r^2} \frac{\partial u_r}{\partial \theta} - \frac{u_\theta}{r^2} \right], \quad (5.7.5)$$

$$\rho_o \frac{\partial^2 u_z}{\partial t^2} = \rho_o B_z + (\lambda + \mu) \frac{\partial e}{\partial z} + \mu \left[\frac{\partial^2 u_z}{\partial r^2} + \frac{1}{r^2} \frac{\partial^2 u_z}{\partial \theta^2} + \frac{\partial^2 u_z}{\partial z^2} + \frac{1}{r} \frac{\partial u_z}{\partial r} \right]. \quad (5.7.6)$$

Spherical coordinates. With (u_r, u_θ, u_ϕ) denoting the displacement components in (r, θ, ϕ) directions, Hooke's laws are

$$T_{rr} = \lambda e + 2\mu \frac{\partial u_r}{\partial r}, \quad (5.7.7)$$

$$T_{\theta\theta} = \lambda e + 2\mu \left(\frac{1}{r} \frac{\partial u_\theta}{\partial \theta} + \frac{u_r}{r} \right), \quad (5.7.8)$$

$$T_{\phi\phi} = \lambda e + 2\mu \left(\frac{1}{r \sin \theta} \frac{\partial u_\phi}{\partial \phi} + \frac{u_r}{r} + \frac{u_\theta \cot \theta}{r} \right), \quad (5.7.9)$$

$$T_{r\theta} = \mu \left(\frac{1}{r} \frac{\partial u_r}{\partial \theta} + \frac{\partial u_\theta}{\partial r} - \frac{u_\theta}{r} \right), \quad (5.7.10)$$

$$T_{\theta\phi} = \mu \left(\frac{1}{r \sin \theta} \frac{\partial u_\theta}{\partial \phi} - \frac{u_\phi \cot \theta}{r} + \frac{1}{r} \frac{\partial u_\phi}{\partial \theta} \right), \quad (5.7.11)$$

$$T_{\phi r} = \mu \left(\frac{1}{r \sin \theta} \frac{\partial u_r}{\partial \phi} + \frac{\partial u_\phi}{\partial r} - \frac{u_\phi}{r} \right), \quad (5.7.12)$$

where

$$e = \frac{\partial u_r}{\partial r} + \frac{2u_r}{r} + \frac{1}{r} \frac{\partial u_\theta}{\partial \theta} + \frac{1}{r \sin \theta} \frac{\partial u_\phi}{\partial \phi} + \frac{u_\theta \cot \theta}{r}, \quad (5.7.13)$$

and Navier's equations of motion are

$$\begin{aligned} \rho_o \frac{\partial^2 u_r}{\partial t^2} = & \rho_o B_r + (\lambda + \mu) \frac{\partial e}{\partial r} + \mu \left\{ \frac{\partial}{\partial r} \left(\frac{1}{r^2} \frac{\partial}{\partial r} (r^2 u_r) \right) \right. \\ & \left. + \frac{1}{r^2 \sin \theta} \frac{\partial}{\partial \theta} \left(\sin \theta \frac{\partial u_r}{\partial \theta} \right) + \frac{1}{r^2 \sin \theta} \frac{\partial^2 u_r}{\partial \phi^2} - \frac{2}{r^2 \sin \theta} \frac{\partial}{\partial \theta} (u_\theta \sin \theta) - \frac{2}{r^2 \sin \theta} \frac{\partial u_\phi}{\partial \phi} \right\}, \end{aligned} \quad (5.7.14)$$

$$\begin{aligned} \rho_o \frac{\partial^2 u_\theta}{\partial t^2} &= \rho_o B_\theta + \frac{(\lambda + \mu)}{r} \frac{\partial e}{\partial \theta} \\ &+ \mu \left\{ \left(\frac{1}{r^2} \frac{\partial}{\partial r} \left(r^2 \frac{\partial u_\theta}{\partial r} \right) \right) + \frac{1}{r^2} \frac{\partial}{\partial \theta} \left(\frac{1}{\sin \theta} \frac{\partial}{\partial \theta} (u_\theta \sin \theta) \right) + \frac{1}{r^2 \sin^2 \theta} \frac{\partial^2 u_\theta}{\partial \phi^2} + \frac{2}{r^2} \frac{\partial u_r}{\partial \theta} - \frac{2 \cot \theta}{r^2 \sin \theta} \frac{\partial u_\phi}{\partial \phi} \right\}. \end{aligned} \quad (5.7.15)$$

$$\begin{aligned} \rho_o \frac{\partial^2 u_\phi}{\partial t^2} &= \rho_o B_\phi + \frac{(\lambda + \mu)}{r \sin \theta} \frac{\partial e}{\partial \phi} \\ &+ \mu \left\{ \frac{1}{r^2} \frac{\partial}{\partial r} \left(r^2 \frac{\partial u_\phi}{\partial r} \right) + \frac{1}{r^2} \frac{\partial}{\partial \theta} \left(\frac{1}{\sin \theta} \frac{\partial}{\partial \theta} (u_\phi \sin \theta) \right) + \frac{1}{r^2 \sin^2 \theta} \frac{\partial^2 u_\phi}{\partial \phi^2} + \frac{2}{r^2 \sin \theta} \frac{\partial u_r}{\partial \phi} + \frac{2 \cot \theta}{r^2 \sin \theta} \frac{\partial u_\theta}{\partial \phi} \right\}. \end{aligned} \quad (5.7.16)$$

5.8 PRINCIPLE OF SUPERPOSITION

Let $u_i^{(1)}$ and $u_i^{(2)}$ be two possible displacement fields corresponding to two body force fields $B_i^{(1)}$ and $B_i^{(2)}$. Let $T_{ij}^{(1)}$ and $T_{ij}^{(2)}$ be the corresponding stress fields. Then

$$\rho_o \frac{\partial^2 u_i^{(1)}}{\partial t^2} = \rho_o B_i^{(1)} + \frac{\partial T_{ij}^{(1)}}{\partial x_j}, \quad (5.8.1)$$

$$\rho_o \frac{\partial^2 u_i^{(2)}}{\partial t^2} = \rho_o B_i^{(2)} + \frac{\partial T_{ij}^{(2)}}{\partial x_j}. \quad (5.8.2)$$

Adding the preceding two equations, we get

$$\rho_o \frac{\partial^2}{\partial t^2} (u_i^{(1)} + u_i^{(2)}) = \rho_o (B_i^{(1)} + B_i^{(2)}) + \frac{\partial}{\partial x_j} (T_{ij}^{(1)} + T_{ij}^{(2)}). \quad (5.8.3)$$

It is clear from the linearity of the strain-displacement relationship, Eq. (5.5.11) and the Hooke's law Eq. (5.5.12), that $T_{ij}^{(1)} + T_{ij}^{(2)}$ is the stress field corresponding to the displacement field $u_i^{(1)} + u_i^{(2)}$. Thus $u_i^{(1)} + u_i^{(2)}$ is also a possible motion under the body force field $B_i^{(1)} + B_i^{(2)}$. The corresponding stress field is given by $T_{ij}^{(1)} + T_{ij}^{(2)}$ and the surface traction needed to maintain the total motion is given by $t_i^{(1)} + t_i^{(2)} = T_{ij}^{(1)} n_j + T_{ij}^{(2)} n_j$. This is the principle of superposition. One application of this principle is that in a given problem, we often assume that the body force is absent, having in mind that its effect, if not negligible, can always be obtained separately and then superimposed onto the solution for the case of vanishing body forces.

A.1 PLANE ELASTIC WAVES

5.9 PLANE IRROTATIONAL WAVES

In this section and the following three sections, we present some simple but important elastodynamic problems using the model of isotropic linearly elastic material.

Consider the motion

$$u_1 = \varepsilon \sin \frac{2\pi}{\ell} (x_1 - c_L t), \quad u_2 = 0, \quad u_3 = 0, \quad (5.9.1)$$

representing an infinite train of sinusoidal plane waves. In this motion, every particle executes simple harmonic oscillations of small amplitude ε around its natural state, the motion being always parallel to the \mathbf{e}_1 direction. All particles on a plane perpendicular to \mathbf{e}_1 are at the same phase of the harmonic motion at any one time [i.e., the same value of $(2\pi/\ell)(x_1 - c_L t)$]. A particle that at time t is at $x_1 + dx_1$ acquires at $t + dt$ the same phase of motion of the particle that is at x_1 at time t , if $(x_1 + dx_1) - c_L(t + dt) = x_1 - c_L t$, i.e., $dx_1/dt = c_L$. Thus, c_L is known as the *phase velocity* (the velocity with which the sinusoidal disturbance of wavelength ℓ is moving in the \mathbf{e}_1 direction). Since the motion of every particle is parallel to the direction of the propagation of wave, it is a *longitudinal wave*.

We shall now obtain the phase velocity of this wave by demanding that the displacement field satisfy the equations of motion, in the form of either $\rho_o(\partial^2 u_i/\partial t^2) = \partial T_{ij}/\partial x_j$ [see Eq. (5.5.10)] or the Navier equations (5.6.4). To use Eq. (5.5.10), we first obtain the strain components, which are

$$E_{11} = \varepsilon \left(\frac{2\pi}{\ell} \right) \cos \frac{2\pi}{\ell} (x_1 - c_L t), \quad E_{22} = E_{23} = E_{12} = E_{13} = E_{33} = 0. \quad (5.9.2)$$

The dilatation $e = E_{kk}$ is given by

$$e = E_{11} + 0 + 0 = E_{11} = \varepsilon \left(\frac{2\pi}{\ell} \right) \cos \frac{2\pi}{\ell} (x_1 - c_L t), \quad (5.9.3)$$

and the nonzero stress components are

$$T_{11} = (\lambda + 2\mu)E_{11} = (\lambda + 2\mu)\varepsilon \left(\frac{2\pi}{\ell} \right) \cos \frac{2\pi}{\ell} (x_1 - c_L t), \quad (5.9.4)$$

$$T_{22} = T_{33} = \lambda E_{11}.$$

Substituting T_{ij} and u_i into Eq. (5.5.10) [Eqs. (5.5.11) and (5.5.12) are trivially satisfied], we have

$$-\rho_o \varepsilon \left(\frac{2\pi}{\ell} \right)^2 c_L^2 \sin \frac{2\pi}{\ell} (x_1 - c_L t) = -(\lambda + 2\mu)\varepsilon \left(\frac{2\pi}{\ell} \right)^2 \sin \frac{2\pi}{\ell} (x_1 - c_L t), \quad (5.9.5)$$

from which we obtain the phase velocity c_L as

$$c_L = \left(\frac{\lambda + 2\mu}{\rho_o} \right)^{1/2}. \quad (5.9.6)$$

As a particle oscillates, its volume changes harmonically [see Eq. (5.9.3)]. Thus, the wave is known as a *dilatational wave*. On the other hand, the spin tensor $\mathbf{W} = (\nabla \mathbf{u})^A$ is clearly zero ($\nabla \mathbf{u}$ is symmetric); therefore, the wave is also known as an *irrotational wave*.

From Eq. (5.9.6), we see that for the plane wave discussed, the phase velocity c_L depends only on the material properties and not on the wave length ℓ . Thus, any disturbance represented by the superposition of any number of one-dimensional plane irrotational wave trains of different wavelengths propagates without changing the form of the disturbance, with the velocity equal to the phase velocity c_L . In fact, we have seen in Example 5.6.1 that any irrotational disturbance given by $u_1 = u(x_1, t)$, $u_2 = u_3 = 0$, is a possible motion in the absence of body forces, provided that $u(x_1, t)$ is a solution of the simple wave equation

$$\frac{\partial^2 u}{\partial t^2} = c_L^2 \frac{\partial^2 u}{\partial x^2}. \quad (5.9.7)$$

It can be easily verified (see Prob. 5.20) that for any function f , the displacement $u = f(s)$, where $s = x_1 \pm c_L t$ satisfies the above wave equation. Thus, disturbances of any form given by $f(s)$ propagate without changing their forms with wave speed c_L . In other words, the phase velocity is also the rate of propagation of a finite train of waves or of any arbitrary disturbance into an undisturbed region.

Example 5.9.1

For a material half-space that lies to the right of the plane $x_1 = 0$, consider the displacement field:

$$u_1 = \alpha \sin \frac{2\pi}{\ell} (x_1 - c_L t) + \beta \cos \frac{2\pi}{\ell} (x_1 - c_L t). \quad (\text{i})$$

- (a) Determine the constants α , β , the wave length ℓ , and the surface tractions on the plane $x_1 = 0$ if the applied displacement on the plane $x_1 = 0$ is given by $\mathbf{u} = b(\sin \omega t)\mathbf{e}_1$.
- (b) Determine the constants α and β , the wave length ℓ , and the displacements on the plane $x_1 = 0$ if the applied surface traction on the plane $x_1 = 0$ is given by $\mathbf{t} = f \sin \omega t \mathbf{e}_1$.

Solution

The given displacement field is the superposition of two longitudinal elastic waves having the same velocity of propagation c_L in the positive x_1 direction and is therefore a possible elastic solution.

- (a) To satisfy the displacement boundary condition, one sets

$$u_1(0, t) = b \sin \omega t, \quad (\text{ii})$$

thus,

$$-\alpha \sin \left(\frac{2\pi c_L t}{\ell} \right) + \beta \cos \left(\frac{2\pi c_L t}{\ell} \right) = b \sin \omega t. \quad (\text{iii})$$

Since this relation must be satisfied for all time t , we have

$$\beta = 0, \quad \alpha = -b, \quad \ell = \frac{2\pi c_L}{\omega}, \quad (\text{iv})$$

and the elastic wave has the form

$$u_1 = -b \sin \frac{\omega}{c_L} (x_1 - c_L t). \quad (\text{v})$$

Note that the wavelength ℓ is inversely proportional to the forcing frequency ω . That is, the higher the forcing frequency, the smaller the wavelength of the elastic wave.

Since $\mathbf{t} = \mathbf{T}(-\mathbf{e}_1) = -(T_{11}\mathbf{e}_1 + T_{21}\mathbf{e}_2 + T_{31}\mathbf{e}_3) = -T_{11}\mathbf{e}_1$; we have, on $x_1 = 0$

$$\mathbf{t} = -(\lambda + 2\mu)(\partial u_1 / \partial x_1)_{x_1=0} \mathbf{e}_1 = (\lambda + 2\mu)(b\omega/c_L) \cos \omega t \mathbf{e}_1. \quad (\text{vi})$$

- (b) To satisfy the traction boundary condition on $x_1 = 0$, one requires that

$$\mathbf{t} = \mathbf{T}(-\mathbf{e}_1) = -T_{11}\mathbf{e}_1 = (f \sin \omega t)\mathbf{e}_1. \quad (\text{vii})$$

That is, at $x_1 = 0$, $T_{11} = -f \sin \omega t$, $T_{12} = T_{13} = 0$. For the assumed displacement field, we have

$$-f \sin \omega t = (\lambda + 2\mu) \frac{2\pi}{\ell} \left[\alpha \cos \frac{2\pi}{\ell} c_L t + \beta \sin \frac{2\pi}{\ell} c_L t \right]. \quad (\text{viii})$$

To satisfy this relation for all time t , we have

$$\alpha = 0, \quad \beta = \frac{-f}{(\lambda + 2\mu)} \left(\frac{\ell}{2\pi} \right), \quad \omega = \frac{2\pi c_L}{\ell}, \quad (\text{ix})$$

and the resulting wave has the form

$$u_1 = \frac{-f c_L}{(\lambda + 2\mu)\omega} \cos \frac{\omega}{c_L} (x_1 - c_L t). \quad (\text{x})$$

We note that not only the wavelength but the amplitude of the resulting wave is inversely proportional to the forcing frequency.

The corresponding displacement component u_1 on the surface $x_1 = 0$ is given by

$$u_1 = \frac{-f c_L}{(\lambda + 2\mu)\omega} \cos \omega t. \quad (\text{xi})$$

5.10 PLANE EQUIVOLUMINAL WAVES

Consider the motion

$$u_1 = 0, \quad u_2 = \varepsilon \sin \frac{2\pi}{\ell} (x_1 - c_T t), \quad u_3 = 0. \quad (\text{5.10.1})$$

This infinite train of plane harmonic wave differs from that discussed in Section 5.9 in that it is a transverse wave. The particle motion is parallel to the \mathbf{e}_2 direction, whereas the disturbance is propagating in the \mathbf{e}_1 direction. For this motion, the only nonzero strain components are

$$E_{12} = E_{21} = \frac{\varepsilon}{2} \left(\frac{2\pi}{\ell} \right) \cos \left(\frac{2\pi}{\ell} \right) (x_1 - c_T t), \quad (\text{5.10.2})$$

and the only nonzero stress components are

$$T_{12} = T_{21} = \mu \varepsilon \left(\frac{2\pi}{\ell} \right) \cos \left(\frac{2\pi}{\ell} \right) (x_1 - c_T t). \quad (\text{5.10.3})$$

Substituting T_{12} and u_2 in the equation of motion,

$$\frac{\partial T_{21}}{\partial x_1} = \rho_o \frac{\partial^2 u_2}{\partial t^2}, \quad (\text{5.10.4})$$

we obtain the phase velocity c_T as

$$c_T = \sqrt{\frac{\mu}{\rho_o}}. \quad (\text{5.10.5})$$

Since the dilatation e is zero at all times, the motion is known as an *equivoluminal wave*. It is also called a *shear wave*. Here again, the phase velocity c_T is independent of the wavelength ℓ , so it again has the additional significance of being the wave velocity of a finite train of equivoluminal waves or of any arbitrary equivoluminal disturbance into an undisturbed region.

The ratio of the two phase velocities c_L and c_T is

$$\frac{c_L}{c_T} = \left(\frac{\lambda + 2\mu}{\mu} \right)^{1/2}. \quad (5.10.6)$$

Since $\lambda = 2\mu\nu/(1 - 2\nu)$, the ratio is found to depend only on ν , in fact

$$\frac{c_L}{c_T} = \left[\frac{2(1 - \nu)}{1 - 2\nu} \right]^{1/2} = \left(1 + \frac{1}{1 - 2\nu} \right)^{1/2}. \quad (5.10.7)$$

For steel, with $\nu = 0.3$, $c_L/c_T = \sqrt{7/2} = 1.87$. We note that since $\nu < 1/2$, c_L is always greater than c_T .

Example 5.10.1

Consider a displacement field:

$$u_2 = \alpha \sin \frac{2\pi}{\ell} (x_1 - c_T t) + \beta \cos \frac{2\pi}{\ell} (x_1 - c_T t), \quad u_1 = u_3 = 0 \quad (i)$$

for a material half-space that lies to the right of the plane $x_1 = 0$.

(a) Determine α , β , ℓ , and $\mathbf{u}(0, t)$ if the applied surface traction on $x_1 = 0$ is $\mathbf{t} = (f \sin \omega t) \mathbf{e}_2$.

(b) Determine α , β and ℓ , and $\mathbf{t}(0, t)$ if the applied displacement on $x_1 = 0$ is $\mathbf{u} = (b \sin \omega t) \mathbf{e}_2$.

Solution

(a) The only nonzero stress components are

$$T_{12} = T_{21} = 2\mu E_{12} = \mu \frac{\partial u_2}{\partial x_1} = \alpha \mu \left(\frac{2\pi}{\ell} \right) \cos \frac{2\pi}{\ell} (x_1 - c_T t) - \beta \mu \left(\frac{2\pi}{\ell} \right) \sin \frac{2\pi}{\ell} (x_1 - c_T t). \quad (ii)$$

On the boundary $x_1 = 0$, outward normal, $\mathbf{n} = -\mathbf{e}_1$, $\mathbf{t} = \mathbf{T}(-\mathbf{e}_1) = -T_{21} \mathbf{e}_2$; thus,

$$-T_{21}(0, t) \mathbf{e}_2 = (f \sin \omega t) \mathbf{e}_2, \quad (iii)$$

so that

$$-\alpha \mu \left(\frac{2\pi}{\ell} \right) \cos \frac{2\pi}{\ell} (c_T t) - \beta \mu \left(\frac{2\pi}{\ell} \right) \sin \frac{2\pi}{\ell} (c_T t) = f \sin \omega t. \quad (iv)$$

Thus,

$$\alpha = 0, \quad \beta = -\frac{f\ell}{2\pi\mu}, \quad \ell = \frac{2\pi c_T}{\omega}, \quad (v)$$

and

$$\mathbf{u}(0, t) = -\frac{\ell f}{2\pi\mu} \cos \omega t \mathbf{e}_2. \quad (vi)$$

(b) The boundary condition $u_2(0, t) = b \sin \omega t$ gives

$$\beta = 0, \quad \alpha = -b, \quad \ell = \frac{2\pi c_T}{\omega}, \quad u_2 = -b \sin \frac{\omega}{c_T} (x_1 - c_T t). \quad (vii)$$

The only nonzero stress components are

$$T_{12} = T_{21} = 2\mu E_{12} = \mu \frac{\partial u_2}{\partial x_1} = -b\mu \left(\frac{\omega}{c_T}\right) \cos\left(\frac{2\pi}{\ell}\right)(x_1 - c_T t), \quad (\text{viii})$$

thus,

$$\mathbf{t}(0, t) = -T_{21}\mathbf{e}_2 = \beta\mu \left(\frac{\omega}{c_T}\right) \cos \omega t \mathbf{e}_2. \quad (\text{ix})$$

Example 5.10.2

Consider the displacement field:

$$u_3 = \alpha \cos \rho x_2 \cos \frac{2\pi}{\ell}(x_1 - ct), \quad u_1 = u_2 = 0. \quad (\text{i})$$

- (a) Show that this is an equivoluminal motion.
- (b) From the equation of motion, determine the phase velocity c in terms of ρ , ℓ , ρ_o , and μ (assuming no body forces).
- (c) This displacement field is used to describe a type of wave guide that is bounded by the plane $x_2 = \pm h$. Find the phase velocity c if these planes are traction free.

Solution

- (a) Since

$$\operatorname{div} \mathbf{u} = \frac{\partial u_1}{\partial x_1} + \frac{\partial u_2}{\partial x_2} + \frac{\partial u_3}{\partial x_3} = 0 + 0 + 0 = 0, \quad (\text{ii})$$

thus there is no change of volume at any time.

- (b) For convenience, let $k = 2\pi/\ell$ and $\omega = kc = 2\pi c/\ell$; then

$$u_3 = \alpha \cos \rho x_2 \cos(kx_1 - \omega t), \quad (\text{iii})$$

where k is known as the wave number and ω is the circular frequency. The only nonzero stresses are given by (note: $u_1 = u_2 = 0$)

$$T_{13} = T_{31} = \mu \frac{\partial u_3}{\partial x_1} = \alpha\mu k[-\cos \rho x_2 \sin(kx_1 - \omega t)], \quad (\text{iv})$$

and

$$T_{23} = T_{32} = \mu \frac{\partial u_3}{\partial x_2} = \alpha\mu\rho[-\sin \rho x_2 \cos(kx_1 - \omega t)]. \quad (\text{v})$$

The substitution of the stress components into the third equation of motion yields (the first two equations are trivially satisfied)

$$\frac{\partial T_{31}}{\partial x_1} + \frac{\partial T_{32}}{\partial x_2} = (\mu k^2 + \mu\rho^2)(-u_3) = \rho_o \frac{\partial^2 u_3}{\partial t^2} = \rho_o \omega^2 (-u_3). \quad (\text{vi})$$

Therefore, with $c_T^2 = \mu/\rho_0$,

$$k^2 + p^2 = (\omega/c_T)^2. \quad (\text{vii})$$

Since $k = 2\pi/\ell$, and $\omega = 2\pi c/\ell$, therefore

$$c = c_T \left[\left(\frac{\ell p}{2\pi} \right)^2 + 1 \right]^{1/2}, \quad (\text{viii})$$

(c) To satisfy the traction free boundary condition at $x_2 = \pm h$, we require that

$$\mathbf{t} = \pm \mathbf{T} \mathbf{e}_2 = \pm (T_{12} \mathbf{e}_1 + T_{22} \mathbf{e}_2 + T_{32} \mathbf{e}_3) = \pm T_{32} \mathbf{e}_3 = 0 \quad \text{at } x_2 = \pm h, \quad (\text{ix})$$

therefore,

$$(T_{32})_{x_2=\pm h} = \pm \mu p \alpha \sin ph \cos (kx_1 - \omega t) = 0. \quad (\text{x})$$

For this relation to be satisfied for all x_1 and t , we must have $\sin ph = 0$. Thus,

$$p = \frac{n\pi}{h}, \quad n = 0, 1, 2, \dots \quad (\text{xi})$$

Each value of n determines a possible displacement field. The phase velocity c corresponding to each of these displacement field (called a *mode*) is given by

$$c = c_T \left[\left(\frac{n\ell}{2h} \right)^2 + 1 \right]^{1/2}. \quad (\text{xii})$$

This result indicates that these equivoluminal waves inside the traction-free boundaries, $x_2 = \pm h$, propagate with speeds c greater than the speed c_T of a plane equivoluminal wave of infinite extent. Note that when $p = 0$, $c = c_T$ as expected.

Example 5.10.3

An infinite train of plane harmonic waves propagates in the direction of the unit vector \mathbf{e}_n . Express the displacement field in vector form for (a) a longitudinal wave and (b) a transverse wave.

Solution

Let \mathbf{x} be the position vector of any point on a plane whose normal is \mathbf{e}_n and whose distance from the origin is d (Figure 5.10-1). Then $\mathbf{x} \cdot \mathbf{e}_n = d$. Thus, so that the particles on the plane will be at the same phase of the harmonic oscillation at any one time, the argument of sine (or cosine) must be of the form $(2\pi/\ell)(\mathbf{x} \cdot \mathbf{e}_n - ct - \eta)$, where η is an arbitrary constant.

(a) For longitudinal waves, \mathbf{u} is parallel to \mathbf{e}_n ; thus

$$\mathbf{u} = \varepsilon \sin \left[\frac{2\pi}{\ell} (\mathbf{x} \cdot \mathbf{e}_n - c_L t - \eta) \right] \mathbf{e}_n. \quad (5.10.8)$$

In particular, if $\mathbf{e}_n = \mathbf{e}_1$,

$$u_1 = \varepsilon \sin \left[\frac{2\pi}{\ell} (x_1 - c_L t - \eta) \right], \quad u_2 = u_3 = 0. \quad (5.10.9)$$

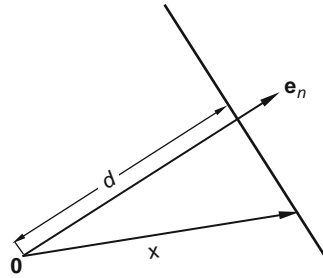

FIGURE 5.10-1

(b) For transverse waves, \mathbf{u} is perpendicular to \mathbf{e}_n . Let \mathbf{e}_t be a unit vector perpendicular to \mathbf{e}_n . Then

$$\mathbf{u} = \varepsilon \sin \left[\frac{2\pi}{\ell} (\mathbf{x} \cdot \mathbf{e}_n - c_T t - \eta) \right] \mathbf{e}_t. \quad (5.10.10)$$

The plane of \mathbf{e}_t and \mathbf{e}_n is known as the *plane of polarization*. In particular, if $\mathbf{e}_n = \mathbf{e}_1$, and $\mathbf{e}_t = \mathbf{e}_2$, then

$$u_1 = 0, \quad u_2 = \varepsilon \sin \frac{2\pi}{\ell} (x_1 - c_T t - \eta), \quad u_3 = 0. \quad (5.10.11)$$

Example 5.10.4

In Figure 5.10-2, all three unit vectors, \mathbf{e}_{n_1} , \mathbf{e}_{n_2} and \mathbf{e}_{n_3} lie in the x_1x_2 plane. Express the displacement components, with respect to the x_i coordinates, of plane harmonic waves for:

- A transverse wave of amplitude ε_1 , wave length ℓ_1 polarized in the x_1x_2 plane and propagating in the direction of \mathbf{e}_{n_1}
- A transverse wave of amplitude ε_2 , wave length ℓ_2 polarized in the x_1x_2 plane and propagating in the direction of \mathbf{e}_{n_2}
- A longitudinal wave of amplitude ε_3 , wave length ℓ_3 propagating in the direction of \mathbf{e}_{n_3}

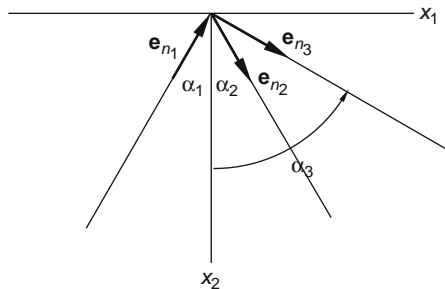

FIGURE 5.10-2

Solution

(a) Referring to Figure 5.10-2, we have

$$\mathbf{e}_{n_1} = \sin \alpha_1 \mathbf{e}_1 - \cos \alpha_1 \mathbf{e}_2, \quad \mathbf{x} \cdot \mathbf{e}_{n_1} = x_1 \sin \alpha_1 - x_2 \cos \alpha_1, \quad \mathbf{e}_{t_1} = \pm (\cos \alpha_1 \mathbf{e}_1 + \sin \alpha_1 \mathbf{e}_2). \quad (\text{i})$$

Thus, using the results of Example 5.10.3, we have

$$\begin{aligned} u_1 &= (\cos \alpha_1) \varepsilon_1 \sin [(2\pi/\ell_1)(x_1 \sin \alpha_1 - x_2 \cos \alpha_1 - c_T t - \eta_1)], \\ u_2 &= (\sin \alpha_1) \varepsilon_1 \sin [(2\pi/\ell_1)(x_1 \sin \alpha_1 - x_2 \cos \alpha_1 - c_T t - \eta_1)], \\ u_3 &= 0, \end{aligned} \quad (\text{ii})$$

where we have chosen the plus sign in the expression for \mathbf{e}_t .

(b) We have

$$\mathbf{e}_{n_2} = \sin \alpha_2 \mathbf{e}_1 + \cos \alpha_2 \mathbf{e}_2, \quad \mathbf{x} \cdot \mathbf{e}_{n_2} = x_1 \sin \alpha_2 + x_2 \cos \alpha_2, \quad \mathbf{e}_{t_2} = (\cos \alpha_2 \mathbf{e}_1 - \sin \alpha_2 \mathbf{e}_2). \quad (\text{iii})$$

Therefore,

$$\begin{aligned} u_1 &= (\cos \alpha_2) \varepsilon_2 \sin [(2\pi/\ell_2)(x_1 \sin \alpha_2 + x_2 \cos \alpha_2 - c_T t - \eta_2)], \\ u_2 &= -(\sin \alpha_2) \varepsilon_2 \sin [(2\pi/\ell_2)(x_1 \sin \alpha_2 + x_2 \cos \alpha_2 - c_T t - \eta_2)], \\ u_3 &= 0. \end{aligned} \quad (\text{iv})$$

(c) We have

$$\mathbf{e}_{n_3} = \sin \alpha_3 \mathbf{e}_1 + \cos \alpha_3 \mathbf{e}_2, \quad \mathbf{x} \cdot \mathbf{e}_{n_3} = x_1 \sin \alpha_3 + x_2 \cos \alpha_3. \quad (\text{v})$$

Therefore,

$$\begin{aligned} u_1 &= (\sin \alpha_3) \varepsilon_3 \sin [(2\pi/\ell_3)(x_1 \sin \alpha_3 + x_2 \cos \alpha_3 - c_L t - \eta_3)], \\ u_2 &= (\cos \alpha_3) \varepsilon_3 \sin [(2\pi/\ell_3)(x_1 \sin \alpha_3 + x_2 \cos \alpha_3 - c_L t - \eta_3)], \\ u_3 &= 0. \end{aligned} \quad (\text{vi})$$

5.11 REFLECTION OF PLANE ELASTIC WAVES

In Figure 5.11-1, the plane $x_2 = 0$ is the free boundary of an elastic medium, occupying the lower half-space $x_2 \geq 0$. We wish to study how an incident plane wave is reflected by the boundary. Consider an incident transverse wave of wavelength ℓ_1 , polarized in the plane of incident with an incident angle α_1 (see Figure 5.11-1).

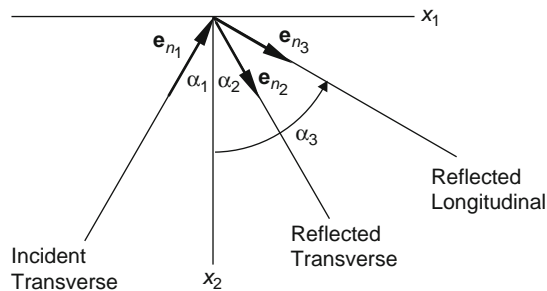

FIGURE 5.11-1

Since $x_2 = 0$ is a free boundary, the surface traction on the plane is zero at all times. Thus, the boundary will generate reflection waves in such a way that when they are superposed on the incident wave, the stress vector on the boundary vanishes at all times.

Let us superpose on the incident transverse wave two reflection waves (see Figure 5.11-1), one transverse, the other longitudinal, both oscillating in the plane of incidence. The reason for superposing not only a reflected transverse wave but also a longitudinal one is that if only one is superposed, the stress-free condition on the boundary in general cannot be met, as will become obvious in the following derivation.

Let u_i denote the displacement components of the superposition of the three waves; then, from the results of Example 5.10.4, we have

$$\begin{aligned} u_1 &= (\cos \alpha_1) \varepsilon_1 \sin \varphi_1 + (\cos \alpha_2) \varepsilon_2 \sin \varphi_2 + (\sin \alpha_3) \varepsilon_3 \sin \varphi_3, \\ u_2 &= (\sin \alpha_1) \varepsilon_1 \sin \varphi_1 - (\sin \alpha_2) \varepsilon_2 \sin \varphi_2 + (\cos \alpha_3) \varepsilon_3 \sin \varphi_3, \\ u_3 &= 0, \end{aligned} \quad (5.11.1)$$

where

$$\begin{aligned} \varphi_1 &= \frac{2\pi}{\ell_1} (x_1 \sin \alpha_1 - x_2 \cos \alpha_1 - c_T t - \eta_1), & \varphi_2 &= \frac{2\pi}{\ell_2} (x_1 \sin \alpha_2 + x_2 \cos \alpha_2 - c_T t - \eta_2), \\ \varphi_3 &= \frac{2\pi}{\ell_3} (x_1 \sin \alpha_3 + x_2 \cos \alpha_3 - c_L t - \eta_3). \end{aligned} \quad (5.11.2)$$

On the free boundary ($x_2 = 0$), where $\mathbf{n} = -\mathbf{e}_2$, the condition $\mathbf{t} = \mathbf{0}$ leads to $\mathbf{T}\mathbf{e}_2 = \mathbf{0}$, i.e.,

$$T_{12} = T_{22} = T_{32} = 0. \quad (5.11.3)$$

Using Hooke's law and noting that $u_3 = 0$ and u_2 does not depend on x_3 , we easily see that the condition $T_{32} = 0$ is automatically satisfied. The other two conditions, in terms of displacement components, are

$$T_{12}/\mu = \partial u_1/\partial x_2 + \partial u_2/\partial x_1 = 0 \quad \text{on } x_2 = 0, \quad (5.11.4)$$

$$T_{22} = (\lambda + 2\mu)(\partial u_2/\partial x_2) + \lambda \partial u_1/\partial x_1 = 0 \quad \text{on } x_2 = 0. \quad (5.11.5)$$

From Eq. (5.11.1) and Eq. (5.11.2), we can obtain

$$\frac{T_{12}}{2\pi\mu} = \frac{\varepsilon_1}{\ell_1} \cos \varphi_1 (\sin^2 \alpha_1 - \cos^2 \alpha_1) + \frac{\varepsilon_2}{\ell_2} \cos \varphi_2 (\cos^2 \alpha_2 - \sin^2 \alpha_2) + \frac{\varepsilon_3}{\ell_3} \cos \varphi_3 \sin 2\alpha_3 = 0, \quad (5.11.6)$$

$$\frac{T_{22}}{2\pi} = -\frac{\varepsilon_1}{\ell_1} \mu \sin 2\alpha_1 \cos \varphi_1 - \frac{\varepsilon_2}{\ell_2} \mu \sin 2\alpha_2 \cos \varphi_2 + \frac{\varepsilon_3}{\ell_3} (\lambda + 2\mu \cos^2 \alpha_3) \cos \varphi_3 = 0. \quad (5.11.7)$$

The preceding two equations, i.e., Eq. (5.11.6) and Eq. (5.11.7), are to be valid at $x_2 = 0$ for whatever values of x_1 and t ; therefore, we must have

$$\cos \varphi_1 = \cos \varphi_2 = \cos \varphi_3 \quad \text{at } x_2 = 0. \quad (5.11.8)$$

That is, at $x_2 = 0$,

$$\varphi_1 = \varphi_2 \pm 2p\pi = \varphi_3 \pm 2q\pi, \quad p \text{ and } q \text{ are integers.} \quad (5.11.9)$$

Thus, from Eq. (5.11.2), we have

$$\frac{2\pi}{\ell_1}(x_1 \sin \alpha_1 - c_T t - \eta_1) = \frac{2\pi}{\ell_2}(x_1 \sin \alpha_2 - c_T t - \eta_2') = \frac{2\pi}{\ell_3}(x_1 \sin \alpha_3 - c_L t - \eta_3'), \quad (5.11.10)$$

where $\eta_2' = \eta_2 - (\pm p \ell_2)$ and $\eta_3' = \eta_3 - (\pm q \ell_3)$.

Equation (5.11.10) can be satisfied for whatever values of x_1 and t only if

$$\frac{\sin \alpha_1}{\ell_1} = \frac{\sin \alpha_2}{\ell_2} = \frac{\sin \alpha_3}{\ell_3}, \quad \frac{c_T}{\ell_1} = \frac{c_T}{\ell_2} = \frac{c_L}{\ell_3}, \quad \frac{\eta_1}{\ell_1} = \frac{\eta_2'}{\ell_2} = \frac{\eta_3'}{\ell_3}. \quad (5.11.11)$$

Thus, with

$$\frac{1}{n} \equiv \frac{c_L}{c_T} = \left(\frac{\lambda + 2\mu}{\mu} \right)^{1/2}, \quad (5.11.12)$$

we have

$$\ell_2 = \ell_1, \quad n \ell_3 = \ell_1, \quad \alpha_1 = \alpha_2, \quad n \sin \alpha_3 = \sin \alpha_1, \quad \eta_2' = \eta_1, \quad n \eta_3' = \eta_1. \quad (5.11.13)$$

That is, the reflected transverse wave has the same wavelength as that of the incident transverse wave and the angle of reflection is the same as the incident angle, the longitudinal wave has a different wave length and a different reflection angle depending on the so-called *refraction index* n given by Eq. (5.11.12). It can be easily shown that

$$\frac{1}{n} \equiv \frac{c_L}{c_T} = \left(\frac{\lambda + 2\mu}{\mu} \right)^{1/2} = \left[\frac{2(1-\nu)}{1-2\nu} \right]^{1/2}. \quad (5.11.14)$$

With $\cos \varphi_i$ dropped out, the boundary conditions Eqs. (5.11.6) and (5.11.7) now become, in view of Eqs. (5.11.13),

$$\varepsilon_1(-\cos 2\alpha_1) + \varepsilon_2(\cos 2\alpha_1) + \varepsilon_3 n(\sin 2\alpha_3) = 0, \quad (5.11.15)$$

$$\varepsilon_1 \sin 2\alpha_1 + \varepsilon_2 \sin 2\alpha_1 - \varepsilon_3 \frac{1}{n} \cos 2\alpha_1 = 0. \quad (5.11.16)$$

These two equations uniquely determine the amplitudes of the reflected waves in terms of the incident amplitude. In fact,

$$\varepsilon_2 = \frac{\cos^2 2\alpha_1 - n^2 \sin 2\alpha_1 \sin 2\alpha_3}{\cos^2 2\alpha_1 + n^2 \sin 2\alpha_1 \sin 2\alpha_3} \varepsilon_1, \quad \varepsilon_3 = \frac{n \sin 4\alpha_1}{\cos^2 2\alpha_1 + n^2 \sin 2\alpha_1 \sin 2\alpha_3} \varepsilon_1. \quad (5.11.17)$$

Thus, the problem of the reflection of a transverse wave polarized in the plane of incidence is solved. We mention that if the incident transverse wave is polarized normal to the plane of incidence, no longitudinal component occurs (see Prob. 5.33). Also, when an incident longitudinal wave is reflected, in addition to the regularly reflected longitudinal wave, there is a transverse wave polarized in the plane of incidence.

The equation $n \sin \alpha_3 = \sin \alpha_1$ in Eq. (5.11.13) is analogous to Snell's law in optics, except here we have reflection instead of refraction. If $\sin \alpha_1 > n$, then $\sin \alpha_3 > 1$ and there is no longitudinal reflected wave, but rather, waves of a more complicated nature will be generated. The angle $\alpha_1 = \sin^{-1} n$ is called the *critical angle*.

5.12 VIBRATION OF AN INFINITE PLATE

Consider an infinite plate bounded by the planes $x_1 = 0$ and $x_1 = \ell$. The faces of these planes may have either a prescribed motion or a prescribed surface traction.

The presence of these two boundaries indicates the possibility of a vibration (a standing wave). We begin by assuming the vibration to be of the form

$$u_1 = u_1(x_1, t), \quad u_2 = u_3 = 0. \quad (5.12.1)$$

In the absence of body forces, the Navier equation in x_1 direction requires that

$$c_L^2 \frac{\partial^2 u_1}{\partial x_1^2} = \frac{\partial^2 u_1}{\partial t^2}, \quad c_L = \sqrt{\frac{\lambda + 2\mu}{\rho_0}}. \quad (5.12.2)$$

A steady-state vibration solution to this equation is of the form

$$u_1 = (A \cos kx_1 + B \sin kx_1)(C \cos c_L kt + D \sin c_L kt), \quad (5.12.3)$$

where the constant A, B, C, D and k are determined by the boundary conditions (see Example 5.12.1). This vibration mode is sometimes termed a *thickness stretch* vibration because the plate is being stretched throughout its thickness. It is analogous to acoustic vibration of organ pipes and to the longitudinal vibration of slender rods.

Another vibration mode can be obtained by assuming the displacement field

$$u_2 = u_2(x_1, t), \quad u_1 = u_3 = 0. \quad (5.12.4)$$

In this case, in the absence of body forces, the Navier equation in the x_2 direction requires that

$$c_T^2 \frac{\partial^2 u_2}{\partial x_1^2} = \frac{\partial^2 u_2}{\partial t^2}, \quad c_T = \sqrt{\frac{\mu}{\rho_0}}, \quad (5.12.5)$$

and the solution is of the same form as in the previous case. Again, the constants A, B, C, D , and k are determined by the boundary conditions (see Example 5.12.2). This vibration is termed *thickness shear* and it is analogous to a vibrating string.

Example 5.12.1

(a) Find the thickness-stretch vibration of a plate, where the left face ($x_1 = 0$) is subjected to a forced displacement $\mathbf{u} = (\alpha \cos \omega t)\mathbf{e}_1$ and the right face $x_1 = \ell$ is fixed. (b) Determine the values of ω that give resonance.

Solution

(a) Using Eq. (5.12.3) and the boundary condition $\mathbf{u}(0, t) = (\alpha \cos \omega t)\mathbf{e}_1$, we have

$$\alpha \cos \omega t = u_1(0, t) = AC \cos c_L kt + AD \sin c_L kt. \quad (i)$$

Therefore,

$$AC = \alpha, \quad k = \frac{\omega}{c_L}, \quad D = 0. \quad (ii)$$

The second boundary condition $\mathbf{u}(\ell, t) = \mathbf{0}$ gives

$$0 = u_1(\ell, t) = \left(\alpha \cos \frac{\omega \ell}{c_L} + BC \sin \frac{\omega \ell}{c_L} \right) \cos \omega t. \quad (\text{iii})$$

Therefore,

$$BC = -\alpha \cos \frac{\omega \ell}{c_L}, \quad (\text{iv})$$

and the vibration is given by

$$u_1(x_1, t) = \alpha \left[\cos \frac{\omega x_1}{c_L} - \frac{1}{\tan(\omega \ell / c_L)} \sin \frac{\omega x_1}{c_L} \right] \cos \omega t. \quad (\text{v})$$

(b) Resonance is indicated by unbounded displacements. This occurs for forcing frequencies corresponding to $\tan(\omega \ell / c_L) = 0$, that is, when

$$\omega = \frac{n\pi c_L}{\ell}, \quad n = 1, 2, 3, \dots \quad (\text{vi})$$

Example 5.12.2

(a) Find the thickness-shear vibration of an infinite plate that has an applied surface traction $\mathbf{t} = -(\beta \cos \omega t)\mathbf{e}_2$ on the plane $x_1 = 0$ and is fixed at the plane $x_1 = \ell$. (b) Determine the resonance frequencies.

Solution

(a) On the plane $x_1 = 0$, $\mathbf{n} = -\mathbf{e}_1$, thus,

$$\mathbf{t} = -\mathbf{T}\mathbf{e}_1 = -(T_{11}\mathbf{e}_1 + T_{21}\mathbf{e}_2 + T_{31}\mathbf{e}_3) = -(\beta \cos \omega t)\mathbf{e}_2. \quad (\text{i})$$

Therefore, on $x_1 = 0$,

$$T_{12}|_{x_1=0} = \beta \cos \omega t. \quad (\text{ii})$$

This shearing stress forces a vibration of the form

$$u_2 = (A \cos kx_1 + B \sin kx_1)(C \cos c_T kt + D \sin c_T kt), \quad u_1 = u_3 = 0. \quad (\text{iii})$$

Using Hooke's law, we have

$$T_{12}|_{x_1=0} = \mu \frac{\partial u_2}{\partial x_1} \Big|_{x_1=0} = \beta \cos \omega t. \quad (\text{iv})$$

That is,

$$\frac{\beta}{\mu} \cos \omega t = kBC \cos c_T kt + kBD \sin c_T kt. \quad (\text{v})$$

Thus,

$$k = \frac{\omega}{c_T}, \quad D = 0, \quad BC = \frac{\beta c_T}{\omega \mu}. \quad (\text{vi})$$

The boundary condition $u_2(\ell, t) = 0$ gives

$$0 = \left(AC \cos \frac{\omega \ell}{c_T} + \frac{\beta c_T}{\omega \mu} \sin \frac{\omega \ell}{c_T} \right) \cos \omega t. \quad (\text{vii})$$

Thus,

$$AC = -\frac{\beta c_T}{\omega \mu} \tan \frac{\omega \ell}{c_T}, \quad (\text{viii})$$

and

$$u_2(x_1, t) = \frac{\beta c_T}{\omega \mu} \left(\sin \frac{\omega x_1}{c_T} - \tan \frac{\omega \ell}{c_T} \cos \frac{\omega x_1}{c_T} \right) \cos \omega t. \quad (\text{ix})$$

(b) Resonance occurs for $\tan \frac{\omega \ell}{c_T} = \infty$, that is,

$$\omega = \frac{n\pi c_T}{2\ell}, \quad n = 1, 3, 5, \dots \quad (\text{x})$$

We remark that these values of ω correspond to free vibration natural frequencies with one face traction-free and one face fixed.

A.2 SIMPLE EXTENSION, TORSION, AND PURE BENDING

In the following few sections, we present some examples of simple three-dimensional elastostatic problems. We begin by considering the problem of simple extension. Again, in all these problems, we assume small deformations so that there is no need to make a distinction between the spatial and the material coordinates in the equations of equilibrium and in the boundary conditions.

5.13 SIMPLE EXTENSION

A cylindrical bar of arbitrary cross-section (Figure 5.13-1) is under the action of equal and opposite normal traction σ distributed uniformly at its two end faces. Its lateral surface is free from any surface traction and body forces are assumed to be absent.

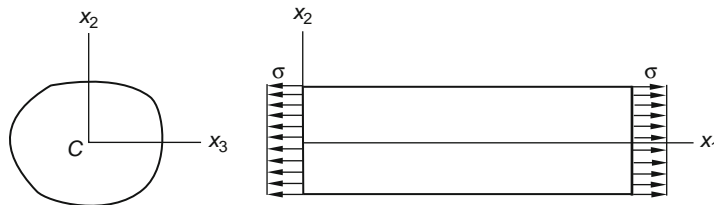

FIGURE 5.13-1

Intuitively, one expects that the state of stress at any point will depend neither on the length of the bar nor on its lateral dimension. In other words, the state of stress in the bar is expected to be the same everywhere. Guided by the boundary conditions that on the plane $x_1 = 0$ and $x_1 = \ell$, $T_{11} = \sigma$, $T_{21} = T_{31} = 0$ and on any $x_2 = \text{constant}$ plane tangent to the lateral surface, $T_{21} = T_{22} = T_{23} = 0$, it seems reasonable to assume that for the whole bar

$$T_{11} = \sigma, \quad T_{22} = T_{23} = T_{12} = T_{13} = T_{23} = 0. \quad (5.13.1)$$

We now proceed to verify that this state of stress is indeed the solution to our problem. We need to verify that (i) all the equations of equilibrium are satisfied, (ii) all the boundary conditions are satisfied, and (iii) there exists a displacement field that corresponds to the assumed stress field.

Regarding (i), since all stress components are either constant or zero, the equations of equilibrium are clearly satisfied in the absence of body forces. Regarding (ii), there are three boundary surfaces. On the two end faces, the boundary conditions are clearly satisfied: $T_{11} = \sigma$, $T_{12} = 0$ and $T_{13} = 0$. On the lateral surface, the unit outward normal does not have an \mathbf{e}_1 component, that is, $\mathbf{n} = 0\mathbf{e}_1 + n_2\mathbf{e}_2 + n_3\mathbf{e}_3$, so that

$$\mathbf{t} = \mathbf{T}\mathbf{n} = n_2(\mathbf{T}\mathbf{e}_2) + n_3(\mathbf{T}\mathbf{e}_3) = n_2(\mathbf{0}) + n_3(\mathbf{0}) = \mathbf{0}. \quad (5.13.2)$$

That is, the traction-free condition on the lateral surface is also satisfied. Regarding (iii), from Hooke's law, we have

$$\begin{aligned} E_{11} &= \frac{1}{E_Y} [T_{11} - \nu(T_{22} + T_{33})] = \frac{\sigma}{E_Y}, & E_{22} &= \frac{1}{E_Y} [T_{22} - \nu(T_{33} + T_{11})] = -\frac{\nu\sigma}{E_Y} = E_{33}, \\ E_{12} &= E_{13} = E_{23} = 0. \end{aligned} \quad (5.13.3)$$

That is, all strain components are constants; therefore the equations of compatibility are automatically satisfied. In fact, it is easily verified that the following single-valued continuous displacement field corresponds to the preceding strain field:

$$u_1 = \left(\frac{\sigma}{E_Y}\right)x_1, \quad u_2 = -\nu\left(\frac{\sigma}{E_Y}\right)x_2, \quad u_3 = -\nu\left(\frac{\sigma}{E_Y}\right)x_3. \quad (5.13.4)$$

Of course, any rigid body displacement field can be added to the preceding without affecting the strain and stress field of the problem. (Also see the following example.)

Example 5.13.1

Obtain the displacement functions by integrating the strain-displacement relations for the strain components given in Eqs. (5.13.3).

Solution

$\partial u_1/\partial x_1 = \sigma/E_Y$, $\partial u_2/\partial x_2 = -\nu\sigma/E_Y$, $\partial u_3/\partial x_3 = -\nu\sigma/E_Y$ gives:

$$u_1 = (\sigma/E_Y)x_1 + f_1(x_2, x_3), \quad u_2 = -(\nu\sigma/E_Y)x_2 + f_2(x_1, x_3), \quad u_3 = -(\nu\sigma/E_Y)x_3 + f_3(x_1, x_2), \quad (i)$$

where $f_1(x_2, x_3)$, $f_2(x_1, x_3)$ and $f_3(x_1, x_2)$ are integration functions. Substituting (i) into the equations:

$$\partial u_1/\partial x_2 + \partial u_2/\partial x_1 = 0, \quad \partial u_1/\partial x_3 + \partial u_3/\partial x_1 = 0 \quad \text{and} \quad \partial u_2/\partial x_3 + \partial u_3/\partial x_2 = 0,$$

we obtain

$$\begin{aligned}\partial f_1(x_2, x_3)/\partial x_2 &= -\partial f_2(x_1, x_3)/\partial x_1 = g_1(x_3), \\ \partial f_1(x_2, x_3)/\partial x_3 &= -\partial f_3(x_1, x_2)/\partial x_1 = g_2(x_2), \\ \partial f_2(x_1, x_3)/\partial x_3 &= -\partial f_3(x_1, x_2)/\partial x_2 = g_3(x_1),\end{aligned}\quad (\text{ii})$$

where $g(x_1)$, $g(x_2)$, $g(x_3)$ are integration functions. Integrations of (ii) give

$$f_1 = g_1(x_3)x_2 + g_4(x_3) \quad \text{and} \quad f_1 = g_2(x_2)x_3 + g_6(x_2), \quad (\text{iii})$$

$$-f_2 = g_1(x_3)x_1 + g_5(x_3), \quad \text{and} \quad f_2 = g_3(x_1)x_3 + g_8(x_1), \quad (\text{iv})$$

$$-f_3 = g_2(x_2)x_1 + g_7(x_2) \quad \text{and} \quad -f_3 = g_3(x_1)x_2 + g_9(x_1). \quad (\text{v})$$

From (iii),

$$g_1(x_3) = a_1x_3 + b_1, \quad g_2(x_2) = a_1x_2 + b_2, \quad g_4(x_3) = b_2x_3 + c_2, \quad g_6(x_2) = b_1x_2 + c_2. \quad (\text{vi})$$

From (iv) and (vi),

$$g_3(x_1) = -a_1x_1 + b_3, \quad g_8(x_1) = -b_1x_1 + c_3, \quad -g_5(x_3) = b_3x_3 + c_3. \quad (\text{vii})$$

From (v), (vi), and (vii),

$$a_1 = 0, \quad g_9(x_1) = b_2x_1 + c_4, \quad g_7(x_2) = b_3x_2 + c_4. \quad (\text{viii})$$

Thus,

$$f_1 = b_1x_2 + b_2x_3 + c_2, \quad f_2 = b_3x_3 - b_1x_1 + c_3, \quad f_3 = -b_2x_1 - b_3x_2 - c_4. \quad (\text{ix})$$

So that

$$\begin{aligned}u_1 &= (\sigma/E_Y)x_1 + b_1x_2 + b_2x_3 + c_2, \\ u_2 &= -(v\sigma/E_Y)x_2 + b_3x_3 - b_1x_1 + c_3, \\ u_3 &= -(v\sigma/E_Y)x_3 - b_2x_1 - b_3x_2 - c_4.\end{aligned}\quad (\text{x})$$

It can be easily verified that

$$u_1 = b_1x_2 + b_2x_3 + c_2, \quad u_2 = b_3x_3 - b_1x_1 + c_3, \quad u_3 = -b_2x_1 - b_3x_2 - c_4$$

describes a rigid body motion (its $\nabla \mathbf{u}$ is antisymmetric).

If the constant cross-sectional area of the prismatic bar is A , the surface traction σ on either end face gives rise to a resultant force of magnitude

$$P = \sigma A, \quad (\text{5.13.5})$$

passing through the centroid of the area A . In terms of P and A , the stress components in the bar are given by

$$[\mathbf{T}] = \begin{bmatrix} P/A & 0 & 0 \\ 0 & 0 & 0 \\ 0 & 0 & 0 \end{bmatrix}. \quad (\text{5.13.6})$$

Since the matrix is diagonal, we know from Chapter 2 that the principal stresses are $(P/A, 0, 0)$. Thus, the maximum normal stress is

$$(T_n)_{\max} = P/A, \quad (\text{5.13.7})$$

acting on normal cross-sectional planes, and the maximum shearing stress is

$$(T_s)_{\max} = (1/2)(P/A), \quad (5.13.8)$$

acting on planes making 45° with the normal cross-sectional plane.

Let the undeformed length of the bar be ℓ , and let $\Delta\ell$ be its elongation. Then $E_{11} = \Delta\ell/\ell$. From $E_{11} = \sigma/E_Y = P/AE_Y$, we have

$$\Delta\ell = \frac{P\ell}{AE_Y}. \quad (5.13.9)$$

Also, if d is the undeformed length of a line in the transverse direction, its elongation Δd is given by:

$$\Delta d = -\frac{\nu Pd}{AE_Y}. \quad (5.13.10)$$

The minus sign indicates the expected contraction of the lateral dimension for a bar under tension.

In reality, when a bar is pulled by equal and opposite resultant forces through the centroids of the end faces, the exact nature of the distribution of the normal stresses on either end face is, more often than not, either unknown or not uniformly distributed. The question naturally arises: Under what conditions can an elastic solution such as the one we just obtained for simple extension be applicable to real problems? The answer to the question is given by the so-called *Saint-Venant's principle*, which can be stated as follows:

If some distribution of forces acting on a portion of the surface of a body is replaced by a different distribution of forces acting on the same portion of the body, then the effects of the two different distributions on the parts of the body sufficiently far removed from the region of application of the forces are essentially the same, provided that the two distributions of forces have the same resultant force and the same resultant couple.

By invoking St. Venant's principle, we may regard the solution we just obtained for "simple extension" gives a valid description of the state of stress in a slender bar except on regions close to the end faces, provided the resultant force on either end passes through the centroid of the cross-sectional area. We further remark that inasmuch as the deviation from the solution is limited to the region near the end faces, the elongation formula for the bar is considered reliable for slender bars. The elongation formula has important application in the so-called statically indeterminate problems involving slender bars.

5.14 TORSION OF A CIRCULAR CYLINDER

Let us consider the elastic deformation of a cylindrical bar of circular cross-section (of radius a and length ℓ), twisted by equal and opposite end moments M_t (Figure 5.14-1). We choose the x_1 -axis to coincide with the axis of the cylinder and the left and right faces to correspond to the plane $x_1 = 0$ and $x_1 = \ell$, respectively.

By the rotational symmetry of the problem, it is reasonable to assume that the motion of each cross-sectional plane, caused by the end moments, is a rigid body rotation about the x_1 -axis. This kind of motion is similar to that of a stack of coins in which each coin is rotated by a slightly different angle than that of the previous coin. It is the purpose of this section to demonstrate that this assumption of the deformation field leads to an exact solution for torsion of a circular bar, within the linear theory of elasticity.

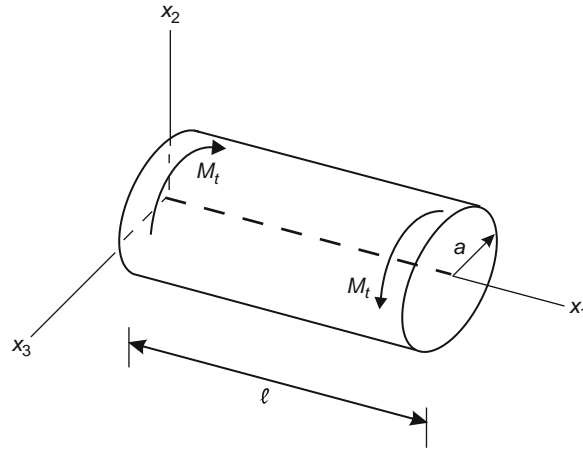

FIGURE 5.14-1

Denoting the small rotation angle at section x_1 by the function $\alpha(x_1)$, we evaluate the corresponding displacement field as

$$\mathbf{u} = (\alpha \mathbf{e}_1) \times \mathbf{r} = (\alpha \mathbf{e}_1) \times (x_1 \mathbf{e}_1 + x_2 \mathbf{e}_2 + x_3 \mathbf{e}_3) = \alpha(x_2 \mathbf{e}_3 - x_3 \mathbf{e}_2). \quad (5.14.1)$$

That is,

$$u_1 = 0, \quad u_2 = -\alpha x_3, \quad u_3 = \alpha x_2. \quad (5.14.2)$$

The nonzero strain components are

$$E_{12} = E_{21} = -\frac{1}{2} x_3 \frac{d\alpha}{dx_1}, \quad E_{13} = E_{31} = \frac{1}{2} x_2 \frac{d\alpha}{dx_1}, \quad (5.14.3)$$

and the nonzero stress components are

$$T_{12} = T_{21} = -\mu x_3 \frac{d\alpha}{dx_1}, \quad T_{13} = T_{31} = \mu x_2 \frac{d\alpha}{dx_1}. \quad (5.14.4)$$

To determine whether this is a possible state of stress in the absence of body forces, we check the equilibrium equation $\partial T_{ij}/\partial x_j = 0$. The $i = 1$ equation is identically satisfied ($0 = 0$). From the second and third equation, we have

$$-\mu x_3 \frac{d^2 \alpha}{dx_1^2} = 0, \quad \mu x_2 \frac{d^2 \alpha}{dx_1^2} = 0. \quad (5.14.5)$$

Thus,

$$\frac{d\alpha}{dx_1} \equiv \alpha' = \text{constant}. \quad (5.14.6)$$

That is, the equations of equilibrium demand that the increment in angular rotation, $d\alpha/dx_1$, be a constant. This constant, here denoted by α' , is known as the *twist per unit length* or simply as *unit twist*.

Next, we check the boundary conditions. On the lateral surface (see Figure 5.14-2), the unit normal vector is given by $\mathbf{n} = (1/a)(x_2\mathbf{e}_2 + x_3\mathbf{e}_3)$; therefore, the surface traction on the lateral surface is

$$[\mathbf{t}] = [\mathbf{T}][\mathbf{n}] = \frac{1}{a} \begin{bmatrix} 0 & T_{12} & T_{13} \\ T_{21} & 0 & 0 \\ T_{31} & 0 & 0 \end{bmatrix} \begin{bmatrix} 0 \\ x_2 \\ x_3 \end{bmatrix} = \frac{1}{a} \begin{bmatrix} x_2T_{12} + x_3T_{13} \\ 0 \\ 0 \end{bmatrix}. \quad (5.14.7)$$

But $x_2T_{12} + x_3T_{13} = \mu(-x_2x_3\alpha' + x_2x_3\alpha') = 0$. Thus, on the lateral surface

$$\mathbf{t} = \mathbf{0}. \quad (5.14.8)$$

On the right end face $x_1 = \ell$, $\mathbf{n} = \mathbf{e}_1$, $\mathbf{t} = \mathbf{T}\mathbf{e}_1 = T_{21}\mathbf{e}_2 + T_{31}\mathbf{e}_3$. That is,

$$\mathbf{t} = \mu\alpha'(-x_3\mathbf{e}_2 + x_2\mathbf{e}_3), \quad (5.14.9)$$

and on the left end face $x_1 = 0$,

$$\mathbf{t} = -\mu\alpha'(-x_3\mathbf{e}_2 + x_2\mathbf{e}_3). \quad (5.14.10)$$

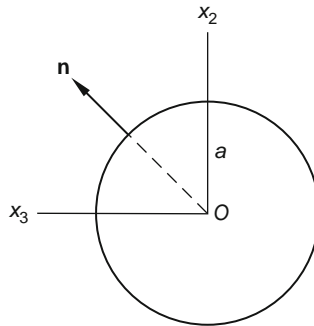

FIGURE 5.14-2

Thus, the stress field given by Eq. (5.14.4) is that inside a circular bar, which is subjected to surface tractions on the left and right end faces in accordance with Eqs. (5.14.9) and (5.14.10), and with its lateral surface free from any surface traction.

We now demonstrate that the surface tractions on the end faces are equivalent to equal and opposite twisting moments on these faces. Indeed, on the faces $x_1 = \ell$, the components of the resultant force are given (see Figure 5.14-3) by

$$R_1 = \int T_{11}dA = 0, \quad R_2 = \int T_{21}dA = -\mu\alpha' \int x_3dA = 0, \quad R_3 = \int T_{31}dA = \mu\alpha' \int x_2dA = 0, \quad (5.14.11)$$

and the components of the resultant moment are given by

$$M_1 = \int (x_2T_{31} - x_3T_{21})dA = \mu\alpha' \int (x_2^2 + x_3^2)dA = \mu\alpha'I_p, \quad M_2 = M_3 = 0. \quad (5.14.12)$$

That is, the resulting moment is

$$\mathbf{M} = \mu\alpha'I_p\mathbf{e}_1 \quad \text{where} \quad I_p = \int (x_2^2 + x_3^2)dA. \quad (5.14.13)$$

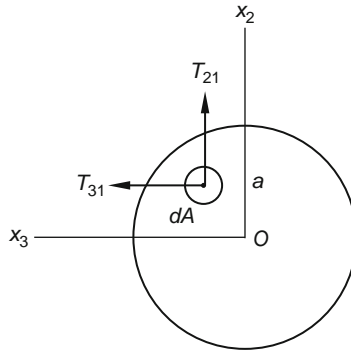

FIGURE 5.14-3

Since the direction of \mathbf{M} is in the direction of the axis of the bar, the moment is a twisting couple. We shall denote its magnitude by

$$M_t = \mu I_p \alpha' \quad \text{or} \quad \alpha' = \frac{M_t}{\mu I_p}. \quad (5.14.14)$$

The resultant moment on the left end face $x_1 = 0$ is clearly $\mathbf{M} = -\mu \alpha' I_p \mathbf{e}_1$, a moment equal in magnitude and opposite in direction to that on the right end face so that indeed, the bar is in equilibrium, under a twisting action. We recall that

$$I_p = \int (x_2^2 + x_3^2) dA = \pi a^4 / 2 \quad (5.14.15)$$

is the polar second moment of the circular cross-section.

In terms of the twisting couple M_t , the stress tensor is

$$[\mathbf{T}] = \begin{bmatrix} 0 & -\frac{M_t x_3}{I_p} & \frac{M_t x_2}{I_p} \\ -\frac{M_t x_3}{I_p} & 0 & 0 \\ \frac{M_t x_2}{I_p} & 0 & 0 \end{bmatrix}. \quad (5.14.16)$$

In reality, when a bar is twisted, the twisting moments are known, but the exact distribution of the applied forces giving rise to the moments is rarely, if ever, known. However, for a slender circular bar, the stress distribution inside the bar is given by Eq. (5.14.16) except in regions near the ends of the bar in accordance with St. Venant's principle, and the formula for calculating the twisting angle per unit length is considered reliable for a slender bar. The twisting angle formula is important for statically indeterminate problems involving slender bars.

Example 5.14.1

For a circular bar of radius a in torsion, (a) find the magnitude and location of the greatest normal and shearing stresses throughout the bar, and (b) find the principal direction at a point on the surface of the bar.

Solution

(a) We first evaluate the principal stresses as a function of position by solving the characteristic equation

$$\lambda^3 - \lambda \left(\frac{M_t}{I_p} \right)^2 (x_2^2 + x_3^2) = 0.$$

Thus, the principal values at any point are

$$\lambda = 0, \quad \text{and} \quad \lambda = \pm \frac{M_t}{I_p} (x_2^2 + x_3^2)^{1/2} = \pm \frac{M_t r}{I_p},$$

where r is the distance from the axis of the bar. Therefore, the maximum and the minimum normal stress are $M_t r / I_p$ and $-M_t r / I_p$, respectively. The magnitude of the maximum shearing stress is then also given by $M_t r / I_p$. Clearly, for the whole bar, the greatest normal and shearing stresses occur on the boundary where $r = a$. That is,

$$(T_n)_{\max} = (T_s)_{\max} = \frac{M_t a}{I_p}. \quad (5.14.17)$$

(b) For the principal value $\lambda = M_t a / I_p$ at a representative point on the boundary $(x_1, 0, a)$, the equations for determining eigenvectors are

$$-\frac{M_t a}{I_p} n_1 - \frac{M_t a}{I_p} n_2 = 0, \quad -\frac{M_t a}{I_p} n_3 = 0.$$

Thus, $n_1 = -n_2$, $n_3 = 0$, and the eigenvector is given by

$$\mathbf{n} = (\sqrt{2}/2)(\mathbf{e}_1 - \mathbf{e}_2). \quad (5.14.18)$$

This normal vector determines a plane perpendicular to the lateral surface at $(x_1, 0, a)$ and making a 45° angle with the x_1 -axis. Frequently, a crack along a helix inclined at 45° to the axis of a circular cylinder under torsion is observed. This is especially true for brittle materials such as cast iron or bone.

Example 5.14.2

Consider the angle of twist for a circular cylinder under torsion to be a function x_1 and t , i.e., $\alpha = \alpha(x_1, t)$. (a) Obtain the differential equation that α must satisfy for it to be a possible motion in the absence of body force. (b) What are the boundary conditions if the plane $x_1 = 0$ is fixed and the plane $x_1 = \ell$ is free of surface tractions.

Solution

(a) From the displacements:

$$u_1 = 0, \quad u_2 = -\alpha(x_1, t)x_3, \quad u_3 = \alpha(x_1, t)x_2,$$

we find the nonzero stress components to be

$$T_{12} = T_{21} = 2\mu E_{12} = -\mu x_3 \frac{\partial \alpha}{\partial x_1}, \quad T_{13} = T_{31} = 2\mu E_{13} = \mu x_2 \frac{\partial \alpha}{\partial x_1}.$$

Both the x_2 - and the x_3 -equations of motion lead to

$$c_T^2 \frac{\partial^2 \alpha}{\partial x_1^2} = \frac{\partial^2 \alpha}{\partial t^2}, \quad c_T^2 = \frac{\mu}{\rho_0}.$$

(b) The boundary conditions are

$$\alpha(0, t) = 0, \quad \frac{\partial \alpha}{\partial x_1}(\ell, t) = 0.$$

5.15 TORSION OF A NONCIRCULAR CYLINDER: ST. VENANT'S PROBLEM

For cross-sections other than circular, the simple displacement field of Section 5.14 will not satisfy the traction-free lateral surface boundary condition. We will show that in order to satisfy this boundary condition, the cross-sections will not remain plane. We begin by assuming a displacement field that still corresponds to small rotations of cross-sections described by a function $\alpha(x_1)$, but in addition, allows for axial displacements $u_1 = \varphi(x_2, x_3)$, describing warping of the cross-sectional plane. Our displacement field now has the form

$$u_1 = \varphi(x_2, x_3), \quad u_2 = -\alpha(x_1)x_3, \quad u_3 = \alpha(x_1)x_2. \quad (5.15.1)$$

The corresponding nonzero stresses are given by

$$\begin{aligned} T_{12} = T_{21} = 2\mu E_{12} &= -\mu x_3 \frac{d\alpha}{dx_1} + \mu \frac{\partial \varphi}{\partial x_2}, \\ T_{13} = T_{31} = 2\mu E_{13} &= \mu x_2 \frac{d\alpha}{dx_1} + \mu \frac{\partial \varphi}{\partial x_3}. \end{aligned} \quad (5.15.2)$$

Both the x_2 - and the x_3 -equation of equilibrium, i.e., $\partial T_{21}/\partial x_1 = 0$ and $\partial T_{31}/\partial x_1 = 0$, lead to the same result as in the circular cross-section case, that the angle of twist per unit length of the bar is a constant. That is,

$$\frac{d\alpha}{dx_1} = \text{constant} \equiv \alpha'. \quad (5.15.3)$$

The x_1 -equation of equilibrium $\partial T_{11}/\partial x_1 + \partial T_{12}/\partial x_2 + \partial T_{13}/\partial x_3 = 0$ requires that the *warping function* satisfies the Laplace equation

$$\nabla^2 \varphi = \frac{\partial^2 \varphi}{\partial x_2^2} + \frac{\partial^2 \varphi}{\partial x_3^2} = 0. \quad (5.15.4)$$

We now compute the surface traction on the lateral surface. Since the bar is of constant cross-section, the unit normal does not have an x_1 component. That is, $\mathbf{n} = n_2 \mathbf{e}_2 + n_3 \mathbf{e}_3$ so that

$$[\mathbf{t}] = [\mathbf{T}][\mathbf{n}] = \begin{bmatrix} 0 & T_{12} & T_{13} \\ T_{12} & 0 & 0 \\ T_{13} & 0 & 0 \end{bmatrix} \begin{bmatrix} 0 \\ n_2 \\ n_3 \end{bmatrix} = \begin{bmatrix} T_{12}n_2 + T_{13}n_3 \\ 0 \\ 0 \end{bmatrix}. \quad (5.15.5)$$

That is,

$$\begin{aligned}\mathbf{t} &= \left[\mu\alpha'(-n_2x_3 + n_3x_2) + \mu \left(\frac{\partial\varphi}{\partial x_2}n_2 + \frac{\partial\varphi}{\partial x_3}n_3 \right) \right] \mathbf{e}_1 \\ &= \mu[\alpha'(-n_2x_3 + n_3x_2) + (\nabla\varphi) \cdot \mathbf{n}] \mathbf{e}_1.\end{aligned}\quad (5.15.6)$$

We require that the lateral surface be traction free, i.e., $\mathbf{t} = \mathbf{0}$, so that on the boundary, the warping function φ must satisfy the condition $\alpha'(-n_2x_3 + n_3x_2) + (\nabla\varphi) \cdot \mathbf{n} = 0$; that is,

$$(\nabla\varphi) \cdot \mathbf{n} = \alpha'(n_2x_3 - n_3x_2) \quad \text{or} \quad \frac{d\varphi}{dn} = \alpha'(n_2x_3 - n_3x_2).\quad (5.15.7)$$

Eqs. (5.15.4) and (5.15.7) define the so-called St-Venant's torsion problem.

5.16 TORSION OF ELLIPTICAL BAR

Let the boundary of an elliptical cylinder be defined by

$$f(x_2, x_3) = \frac{x_2^2}{a^2} + \frac{x_3^2}{b^2} = 1.\quad (5.16.1)$$

The unit normal vector is given by

$$\mathbf{n} = \frac{\nabla f}{|\nabla f|} = \frac{2}{|\nabla f|} \left[\frac{x_2}{a^2} \mathbf{e}_2 + \frac{x_3}{b^2} \mathbf{e}_3 \right] = \frac{2}{a^2b^2|\nabla f|} [b^2x_2\mathbf{e}_2 + a^2x_3\mathbf{e}_3].\quad (5.16.2)$$

From Eqs. (5.15.7) and (5.16.2), we obtain

$$\left(\frac{\partial\varphi}{\partial x_2} \right) b^2x_2 + \left(\frac{\partial\varphi}{\partial x_3} \right) a^2x_3 = \alpha'x_2x_3(b^2 - a^2).\quad (5.16.3)$$

Now consider the following warping function:

$$\varphi = Ax_2x_3.\quad (5.16.4)$$

This warping function clearly satisfies the Laplace equation, Eq. (5.15.4). Substituting this function in Eq. (5.16.3), we obtain

$$A = \alpha' \left(\frac{b^2 - a^2}{a^2 + b^2} \right).\quad (5.16.5)$$

Thus, the warping function $\varphi = \alpha' \left(\frac{b^2 - a^2}{a^2 + b^2} \right) x_2x_3$ solves the problem of torsion of an elliptical bar. The non-zero stress components are given by

$$T_{21} = T_{12} = - \left(\frac{2\mu a^2}{a^2 + b^2} \right) \alpha' x_3, \quad T_{31} = T_{13} = \left(\frac{2\mu b^2}{a^2 + b^2} \right) \alpha' x_2.\quad (5.16.6)$$

This distribution of stresses gives rise to a surface traction on the end face $x_1 = \ell$ as

$$\mathbf{t} = T_{21}\mathbf{e}_2 + T_{31}\mathbf{e}_3 = \left(\frac{2\mu\alpha'}{a^2 + b^2} \right) [-a^2x_3\mathbf{e}_2 + b^2x_2\mathbf{e}_3].\quad (5.16.7)$$

The components of the resultant force and resultant moment on this end face can be easily found to be

$$R_1 = R_2 = R_3 = M_2 = M_3 = 0, \quad (5.16.8)$$

$$M_1 = \int (x_2 T_{31} - x_3 T_{21}) dA = \frac{2\mu\alpha'}{a^2 + b^2} \left[a^2 \int x_3^2 dA + b^2 \int x_2^2 dA \right] = \frac{2\mu\alpha'}{a^2 + b^2} (a^2 I_{22} + b^2 I_{33}). \quad (5.16.9)$$

We see that there is no resultant force; there is only a couple with the couple vector along x_1 -axis, the axis of the bar. Clearly, an equal and opposite couple acts on the left end face $x_1 = 0$ so that the bar is under torsion.

For the elliptical cross-section, $I_{22} = \pi b^3 a/4$ and $I_{33} = \pi a^3 b/4$. Thus, from Eq. (5.16.9), the angle of twist per unit length is given by

$$\alpha' = \frac{M_t(a^2 + b^2)}{\mu\pi a^3 b^3}, \quad (5.16.10)$$

where we have denoted M_1 by M_t . In terms of M_t , the nonzero stress components are

$$T_{12} = T_{21} = -\frac{2M_t x_3}{\pi a b^3}, \quad T_{13} = T_{31} = \frac{2M_t x_2}{\pi a^3 b}. \quad (5.16.11)$$

The magnitude of shear stress on the cross-sectional plane is given by

$$T_s = \sqrt{\left(\frac{-2M_t x_3}{\pi a b^3}\right)^2 + \left(\frac{2M_t x_2}{\pi a^3 b}\right)^2} = \left(\frac{2M_t}{\pi a b}\right) \left(\frac{x_3^2}{b^4} + \frac{x_2^2}{a^4}\right)^{1/2}. \quad (5.16.12)$$

Example 5.16.1

For an elliptical bar in torsion, (a) find the magnitude of the maximum normal and shearing stress at any point of the bar. (b) Find the variation of shear stress on a cross-sectional plane along a radial line $x_2 = kx_3$. (c) Find the shear stress at the boundary on the cross-sectional plane and show that the largest shear stress occurs at the end of the minor axis of the ellipse.

Solution

(a) For the stress tensor:

$$[\mathbf{T}] = \begin{bmatrix} 0 & T_{12} & T_{13} \\ T_{12} & 0 & 0 \\ T_{13} & 0 & 0 \end{bmatrix}$$

where T_{12} and T_{13} are given by Eq. (5.16.11), the characteristic equation is

$$\lambda^3 - \lambda \left(\frac{2M_t}{\pi a b}\right)^2 \left[\frac{x_2^2}{a^4} + \frac{x_3^2}{b^4}\right] = 0. \quad (5.16.13)$$

The roots are $\lambda = 0$, and $\lambda = \pm \frac{2M_t}{\pi a b} \left(\frac{x_2^2}{a^4} + \frac{x_3^2}{b^4}\right)^{1/2}$. Thus,

$$(T_n)_{\max} = (T_s)_{\max} = \frac{2M_t}{\pi a b} \left(\frac{x_2^2}{a^4} + \frac{x_3^2}{b^4}\right)^{1/2}. \quad (5.16.14)$$

Comparing this equation with Eq. (5.16.12), we see that the shearing stress at every point on a cross-section is the local maximum shear stress.

(b) Along a radial line $x_2 = kx_3$, where k is the slope of the radial line

$$T_s = \frac{2M_t}{\pi ab} \left(\frac{k^2 x_3^2}{a^4} + \frac{x_3^2}{b^4} \right)^{1/2} = \frac{2M_t |x_3|}{\pi ab} \sqrt{\frac{k^2}{a^4} + \frac{1}{b^4}}. \quad (5.16.15)$$

That is, the shear stress on a cross-section varies linearly along the radial distance. The largest shear stress for every radial line occurs at the boundary.

(c) Along the boundary, $x_2^2/a^2 + x_3^2/b^2 = 1$ so that $x_2^2 = a^2(1 - x_3^2/b^2)$, thus

$$T_s = \frac{2M_t}{\pi a^2 b^3} [b^4 - (b^2 - a^2)x_3^2]^{1/2}. \quad (5.16.16)$$

Let $b > a$, then the largest shear stress occurs at $x_3 = 0$ and $x_2 = a$, the end point of the minor axis with

$$(T_s)_{\max} = \frac{2M_t}{\pi a^2 b}. \quad (5.16.17)$$

At $x_2 = 0$ and $x_3 = b$, the end point of the major axis,

$$T_s = \frac{2M_t}{\pi a b^2}. \quad (5.16.18)$$

The ratio of the shear stress at the end point of the minor axis to that at the end point of the major axis is b/a . Of course, for a circle, the shear stress is constant on the boundary.

5.17 PRANDTL'S FORMULATION OF THE TORSION PROBLEM

Let

$$T_{12} = \frac{\partial \psi}{\partial x_3}, \quad T_{13} = -\frac{\partial \psi}{\partial x_2} \quad \text{all other } T_{ij} = 0. \quad (5.17.1)$$

The function $\psi(x_2, x_3)$ is known as Prandtl's stress function. The only equation of equilibrium that needs to be checked is the x_1 -equation: $\partial T_{12}/\partial x_2 + \partial T_{13}/\partial x_3 = 0$. Substituting the above stress components into it, we obtain

$$\frac{\partial}{\partial x_2} \frac{\partial \psi}{\partial x_3} - \frac{\partial}{\partial x_3} \frac{\partial \psi}{\partial x_2} = 0. \quad (5.17.2)$$

Thus, the equations of equilibrium are satisfied for any arbitrary function of $\psi(x_2, x_3)$, so long as it is continuous to the second derivative. However, not every $\psi(x_2, x_3)$ gives rise to compatible strain components. To derive the condition for compatible strain field, we can either use the compatibility equations derived in Chapter 3 (see Prob. 5.55) or make use of the relation between the stress function $\psi(x_2, x_3)$ and the warping function $\varphi(x_2, x_3)$ defined for the displacement field in the last section. Prandtl's stress function is related to the warping function by

$$T_{12} = \frac{\partial \psi}{\partial x_3} = -\mu x_3 \frac{d\alpha}{dx_1} + \mu \frac{\partial \varphi}{\partial x_2}, \quad T_{13} = -\frac{\partial \psi}{\partial x_2} = \mu x_2 \frac{d\alpha}{dx_1} + \mu \frac{\partial \varphi}{\partial x_3}, \quad (5.17.3)$$

from which we have

$$\frac{\partial^2 \psi}{\partial x_3^2} = -\mu \frac{d\alpha}{dx_1} + \mu \frac{\partial^2 \varphi}{\partial x_3 \partial x_2} \quad \text{and} \quad \frac{\partial^2 \psi}{\partial x_2^2} = -\mu \frac{d\alpha}{dx_1} - \mu \frac{\partial^2 \varphi}{\partial x_2 \partial x_3}. \quad (5.17.4)$$

Thus,

$$\nabla^2 \psi = \frac{\partial^2 \psi}{\partial x_3^2} + \frac{\partial^2 \psi}{\partial x_2^2} = -2\mu\alpha'. \quad (5.17.5)$$

Equation (5.17.5) not only ensures that the compatibility conditions are satisfied, it also provides a relationship between the stress function and the angle of twist per unit length $\alpha' \equiv d\alpha/dx_1$. Eq. (5.17.5) is known as the Poisson Equation.

To derive the boundary condition for ψ , we let the lateral surface be described by

$$f(x_2, x_3) = \text{constant}, \quad (5.17.6)$$

then, the normal to the lateral surface is

$$\mathbf{n} = \frac{\nabla f}{|\nabla f|} = \frac{1}{|\nabla f|} \left(\frac{\partial f}{\partial x_2} \mathbf{e}_2 + \frac{\partial f}{\partial x_3} \mathbf{e}_3 \right). \quad (5.17.7)$$

The boundary condition $T_{12}n_2 + T_{13}n_3 = 0$ [see Eq. (5.15.5)] becomes

$$\frac{\partial \psi}{\partial x_3} \frac{\partial f}{\partial x_2} - \frac{\partial \psi}{\partial x_2} \frac{\partial f}{\partial x_3} = 0 \quad \text{or} \quad \frac{(\partial \psi / \partial x_2)}{(\partial \psi / \partial x_3)} = \frac{(\partial f / \partial x_2)}{(\partial f / \partial x_3)}. \quad (5.17.8)$$

That is, $\nabla \psi$ is parallel to ∇f . Since ∇f is perpendicular to the surface $f(x_2, x_3) = \text{constant}$, so is $\nabla \psi$, which is also perpendicular to $\psi(x_2, x_3) = \text{constant}$. Thus,

$$\psi = C \quad \text{on the boundary.} \quad (5.17.9)$$

Without loss of generality, we can choose the constant C to be zero. Thus, in summary, in Prandtl's formulation, the torsion problem is reduced to

$$\frac{\partial^2 \psi}{\partial x_3^2} + \frac{\partial^2 \psi}{\partial x_2^2} = -2\mu\alpha' \quad \text{with boundary condition } \psi = 0. \quad (5.17.10)$$

The twisting moment is given by:

$$M_t = \int (x_2 T_{31} - x_3 T_{21}) dA = - \int \left(x_2 \frac{\partial \psi}{\partial x_2} + x_3 \frac{\partial \psi}{\partial x_3} \right) dA = - \int \left(\frac{\partial(\psi x_2)}{\partial x_2} + \frac{\partial(\psi x_3)}{\partial x_3} - 2\psi \right) dA. \quad (5.17.11)$$

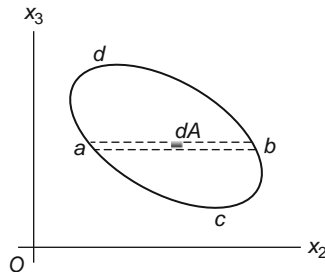

FIGURE 5.17-1

Now,

$$\int \frac{\partial(\psi, x_2)}{\partial x_2} dA = \int_c^d \left[\int_a^b \frac{\partial(\psi, x_2)}{\partial x_2} dx_2 \right] dx_3,$$

where $x_2 = a(x_3)$ and $x_2 = b(x_3)$ are the two end points (on the boundary) along a constant x_3 line, and $x_3 = c$ and $x_3 = d$ are the two extreme boundary points for the region of integration (see Figure 5.17-1). Thus, since $\psi = 0$ on the boundary, we have

$$\int_a^b \frac{\partial(\psi, x_2)}{\partial x_2} dx_2 = \psi, x_2 \Big|_{x_2=a}^{x_2=b} = \psi(b)b - \psi(a)a = 0,$$

so that

$$\int \frac{\partial(\psi, x_2)}{\partial x_2} dA = 0 \quad \text{and similarly} \quad \int \frac{\partial(\psi, x_3)}{\partial x_3} dA = 0. \quad (5.17.12)$$

Thus,

$$M_t = \int 2\psi dA. \quad (5.17.13)$$

Example 5.17.1

Consider the stress function $\psi = B(x_2^2 + x_3^2 - a^2)$. Show that it solves the torsion problem for a circular cylinder of radius a .

Solution

On the boundary, $r^2 = x_2^2 + x_3^2 = a^2$, thus, $\psi = 0$. To satisfy the Poisson equation (5.17.10), we substitute $\psi = B(x_2^2 + x_3^2 - a^2)$ in Eq. (5.17.10) and obtain

$$B = -\frac{\mu\alpha'}{2}, \quad \psi = -\frac{\mu\alpha'}{2}(x_2^2 + x_3^2 - a^2).$$

Now, using Eq. (5.17.13), we obtain

$$M_t = \int 2\psi dA = -\mu\alpha' \int_0^a (r^2 - a^2) 2\pi r dr = \mu\alpha' \left(\frac{\pi a^4}{2} \right) = \mu\alpha' I_p.$$

Example 5.17.2

Show that the shearing stress at any point on a cross-section is tangent to the $\psi = \text{constant}$ curve passing through that point and that the magnitude of the shearing stress is equal to the magnitude of $|\nabla\psi|$.

Solution

From $\psi(x_2, x_3) = C$, we have

$$d\psi = \frac{\partial\psi}{\partial x_2} dx_2 + \frac{\partial\psi}{\partial x_3} dx_3 = 0 \quad \text{or} \quad -\frac{\partial\psi}{\partial x_2} / \frac{\partial\psi}{\partial x_3} = \left(\frac{dx_3}{dx_2} \right)_{\psi=C}.$$

Now, using the definition of stress function, Eq. (5.17.1), $T_{12} = \frac{\partial \psi}{\partial x_3}$, $T_{13} = -\frac{\partial \psi}{\partial x_2}$, we obtain

$$\frac{T_{13}}{T_{12}} = \left(\frac{dx_3}{dx_2} \right)_{\psi=C}$$

Thus, the vector $\mathbf{T}_s = T_{12}\mathbf{e}_2 + T_{13}\mathbf{e}_3$ is tangent to the curve $\psi(x_2, x_3) = C$. Furthermore,

$$|\nabla \psi|^2 = \left(\frac{\partial \psi}{\partial x_2} \right)^2 + \left(\frac{\partial \psi}{\partial x_3} \right)^2 = T_{13}^2 + T_{12}^2 = T_s^2.$$

We also note that $|\nabla \psi| = |\partial \psi / \partial n|$ where \mathbf{n} is in the normal direction to $\psi(x_2, x_3) = C$.

Example 5.17.3

Show that the boundary value problem for determining the membrane elevation $h(x_2, x_3)$ in the x_1 direction (see Figure 5.17-2), relative to that of the fixed boundary of the membrane, due to a uniform pressure p exerted on the lower side of the membrane is

$$\frac{\partial^2 h}{\partial x_3^2} + \frac{\partial^2 h}{\partial x_2^2} = -\frac{p}{S}$$

with $h = 0$ on the boundary, where S is the uniform tensile force per unit length exerted by the boundary on the membrane. The weight of the membrane is neglected.

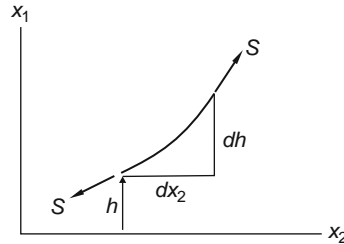

FIGURE 5.17-2

Solution

Due to the pressure acting on the membrane, a differential rectangular element of the membrane with sides dx_2 and dx_3 is subjected to three net forces in the x_1 (upward) direction.

(i) The resultant force due to pressure: $p dx_2 dx_3$, (ii) the net force due to the membrane tensile force S on the pair of the rectangular membrane sides dx_3 , given by (assume small slopes for the membrane curve):

$$-(S dx_3) \frac{\partial h}{\partial x_2} + (S dx_3) \left(\frac{\partial h}{\partial x_2} + \frac{\partial}{\partial x_2} \frac{\partial h}{\partial x_2} dx_2 \right) = S \frac{\partial^2 h}{\partial x_2^2} dx_3 dx_2,$$

and (iii) the net force on the pair of sides of length dx_2 , given by $S \frac{\partial^2 h}{\partial x_3^2} dx_2 dx_3$.

Equilibrium of this element requires that the sum of these forces must be zero. That is

$$\frac{\partial^3 h}{\partial x_2^2} + \frac{\partial^3 h}{\partial x_3^2} = -\frac{\rho}{S} \quad \text{with } h = 0 \text{ on the boundary.} \quad (5.17.14)$$

We see that the boundary value problem for the membrane elevation $h(x_2, x_3)$ is the same as that for the stress function $\psi(x_2, x_3)$ if ρ/S is replaced with $2\mu\alpha'$.

The analogy between $h(x_2, x_3)$ and $\psi(x_2, x_3)$ provides a convenient way to visualize the distribution of the stress function. For example, the curves of constant elevation h in a membrane are analogous to the curves of constant stress function ψ and the location of the largest slope in a membrane provides information on the location of the maximum shearing stress. The constant elevation curves and the location of the maximum slope for a membrane can often be visualized without actually solving the boundary value problem. The analogy has also been used to experimentally determine the stresses in cylindrical bars of various cross-sectional shape under torsion.

5.18 TORSION OF A RECTANGULAR BAR

Let the cross-section be defined by $-a \leq x_2 \leq a$ and $-b \leq x_3 \leq b$. We seek a solution of the stress function $\psi(x_2, x_3)$ satisfying the boundary value problem defined by Eq. (5.17.10). That is,

$$\frac{\partial^2 \psi}{\partial x_3^2} + \frac{\partial^2 \psi}{\partial x_2^2} = -2\mu\alpha', \quad (5.18.1)$$

with boundary conditions

$$\psi = 0 \quad \text{at } x_2 = \pm a \quad \text{and} \quad x_3 = \pm b. \quad (5.18.2)$$

Due to symmetry of the problem, the stress function $\psi(x_2, x_3)$ will clearly be an even function of x_2 and x_3 . Thus, we let

$$\psi = \sum_{n=1,3,5}^{\infty} F_n(x_3) [\cos(n\pi x_2/2a)]. \quad (5.18.3)$$

This choice of ψ clearly satisfies the boundary condition $\psi = 0$ at $x_2 = \pm a$. Substituting the preceding equation in Eq. (5.18.1), we obtain

$$(-1/2\mu\alpha') \sum_{n=1,3,5}^{\infty} [\cos(n\pi x_2/2a)] \left[d^2 F_n(x_3)/dx_3^2 - (n\pi/2a)^2 F_n(x_3) \right] = 1. \quad (5.18.4)$$

It can be obtained from Fourier analysis that

$$1 = \sum_{n=1,3,5}^{\infty} (4/n\pi)(-1)^{(n-1)/2} [\cos(n\pi x_2/2a)], \quad -a < x_2 < a. \quad (5.18.5)$$

Comparing the preceding two equations, we have

$$d^2 F_n/dx_3^2 - (n\pi/2a)^2 F_n = (-2\mu\alpha')(4/n\pi)(-1)^{(n-1)/2}, \quad (5.18.6)$$

from which

$$F_n = A \sinh(n\pi x_3/2a) + B \cosh(n\pi x_3/2a) + (2\mu\alpha')(16a^2/\pi^3 n^3)(-1)^{(n-1)/2}. \quad (5.18.7)$$

For F_n to be an even function of x_3 , the constant A must be zero. The boundary condition that $\psi = 0$ at $x_3 = \pm b$ then gives:

$$B \cosh (n\pi b/2a) + (32\mu\alpha'a^2/\pi^3n^3)(-1)^{(n-1)/2} = 0. \quad (5.18.8)$$

With B determined from the preceding equation, we have

$$F_n = (32\mu\alpha'a^2/\pi^3n^3)(-1)^{(n-1)/2}\{1 - \cosh (n\pi x_3/2a)/\cosh (n\pi b/2a)\}. \quad (5.18.9)$$

Thus,

$$\psi = \left(\frac{32\mu\alpha'a^2}{\pi^3}\right) \sum_{n=1,3,5}^{\infty} \frac{1}{n^3} (-1)^{(n-1)/2} \left\{1 - \frac{\cosh (n\pi x_3/2a)}{\cosh (n\pi b/2a)}\right\} \cos \frac{n\pi x_2}{2a}. \quad (5.18.10)$$

The stress components are given by Eq. (5.17.1). We leave it as an exercise (Prob. 5.56) to show that the maximum shearing stress occurs at the midpoint of the longer sides, given by (assuming $b > a$):

$$(T_s)_{\max} = 2\mu\alpha'a - \left(\frac{16\mu\alpha'a}{\pi^2}\right) \sum_{n=1,3,5}^{\infty} \left(\frac{1}{n^2 \cosh (n\pi b/2a)}\right), \quad b > a, \quad (5.18.11)$$

and the relation between the twisting moment M_t and the twisting angle per unit length α' is given by (see Prob. 5.57):

$$M_t = \frac{1}{3}\mu\alpha'(2a)^3(2b) \left[1 - \left(\frac{192}{\pi^5}\right) \frac{a}{b} \sum_{n=1,3,5}^{\infty} \frac{1}{n^5} \left(\tanh \frac{n\pi b}{2a}\right)\right]. \quad (5.18.12)$$

For a very narrow rectangle ($b/a \rightarrow \infty$, $\cosh (n\pi b/2a) \rightarrow \infty$, $\tanh (n\pi b/2a) \rightarrow 1$), we have

$$(T_s)_{\max} \rightarrow 2\mu\alpha'a, \quad M_t \rightarrow \frac{1}{3}\mu\alpha'(2a)^3(2b) \left(1 - 0.630\frac{a}{b}\right). \quad (5.18.13)$$

5.19 PURE BENDING OF A BEAM

A *beam* is a bar acted on by forces in an axial plane, which chiefly causes bending of the bar. When a beam or portion of a beam is acted on by end couples only, it is said to be in *pure bending* or *simple bending*. We shall consider the case of a cylindrical bar of arbitrary cross-section that is in pure bending.

Figure 5.19-1 shows a bar of uniform cross-section. We choose the x_1 axis to pass through the cross-sectional centroids and let $x_1 = 0$ and $x_1 = \ell$ correspond to the left and the right faces of the bar, respectively.

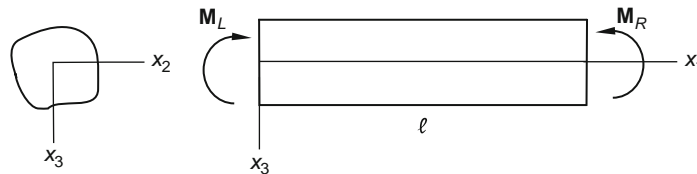

FIGURE 5.19-1

For the pure bending problem, we seek the state of stress that corresponds to a traction-free lateral surface and a distribution of normal surface tractions on the end faces that is equivalent to a bending couple $\mathbf{M}_R = M_2\mathbf{e}_2 + M_3\mathbf{e}_3$ on the right face and a bending couple $\mathbf{M}_L = -\mathbf{M}_R$ on the left end face. (We note that the M_1 is absent because it corresponds to a twisting couple.) Guided by the state of stress associated with simple extension, we tentatively assume that T_{11} is the only nonzero stress components.

To satisfy equilibrium in the absence of body forces, we must have

$$\frac{\partial T_{11}}{\partial x_1} = 0. \quad (5.19.1)$$

That is, $T_{11} = T_{11}(x_2, x_3)$. The corresponding strains are

$$E_{11} = \frac{T_{11}}{E_Y}, \quad E_{22} = E_{33} = -\nu \frac{T_{11}}{E_Y}, \quad E_{12} = E_{13} = E_{23} = 0. \quad (5.19.2)$$

Since we have begun with an assumption on the state of stress, we must check whether these strains are compatible. Substituting the strains into the compatibility equations [Eqs. (3.16.7) to (3.16.12)], we obtain

$$\frac{\partial^2 T_{11}}{\partial x_2^2} = 0, \quad \frac{\partial^2 T_{11}}{\partial x_3^2} = 0, \quad \frac{\partial^2 T_{11}}{\partial x_2 \partial x_3} = 0, \quad (5.19.3)$$

which can be satisfied only if T_{11} is a linear function of the form

$$T_{11} = \alpha + \beta x_2 + \gamma x_3. \quad (5.19.4)$$

We shall take $\alpha = 0$ because it corresponds to the state of stress in simple extension, which we already considered earlier. With $\alpha = 0$, let us evaluate the surface traction on the boundaries of the bar.

On the lateral surface, the normal vector does not have a component in the e_1 direction, i.e., $\mathbf{n} = n_2\mathbf{e}_2 + n_3\mathbf{e}_3$. As a consequence,

$$[\mathbf{t}] = [\mathbf{T}] [\mathbf{n}] = \begin{bmatrix} T_{11} & 0 & 0 \\ 0 & 0 & 0 \\ 0 & 0 & 0 \end{bmatrix} \begin{bmatrix} 0 \\ n_2 \\ n_3 \end{bmatrix} = [\mathbf{0}].$$

This is what it should be for pure bending.

On the right end face, $x_1 = \ell$, $\mathbf{n} = \mathbf{e}_1$, so that

$$\mathbf{t} = \mathbf{T}\mathbf{e}_1 = T_{11}\mathbf{e}_1. \quad (5.19.5)$$

This distribution of surface tractions gives rise to zero resultant force, as shown here:

$$R_1 = \int T_{11} dA = \beta \int x_2 dA + \gamma \int x_3 dA = 0, \quad R_2 = R_3 = 0,$$

where the integrals in the equation for R_1 are the first moments about a centroidal axis, which, by the definition of centroidal axis, are zero. With the resultant force being zero, the resultant is a couple $\mathbf{M}_R = M_2\mathbf{e}_2 + M_3\mathbf{e}_3$ at $x_1 = \ell$ (the right face) with

$$M_2 = \int x_3 T_{11} dA = \beta \int x_2 x_3 dA + \gamma \int x_3^2 dA = \beta I_{23} + \gamma I_{22}, \quad (5.19.6)$$

$$M_3 = - \int x_2 T_{11} dA = -\beta \int x_2^2 dA - \gamma \int x_2 x_3 dA = -\beta I_{33} - \gamma I_{23} \quad (5.19.7)$$

where

$$I_{23} = \int x_2 x_3 dA, \quad I_{22} = \int x_3^2 dA, \quad I_{33} = \int x_2^2 dA \quad (5.19.8)$$

are the second moments of the area. There is an equal and opposite couple on the left face.

We now assume, without any loss of generality, that we have chosen the x_2 and x_3 axes to coincide with the principal axes of the cross-sectional area. Then the product of second moment $I_{23} = 0$. In this case, from Eqs. (5.19.6) and (5.19.7), we have

$$\beta = -\frac{M_3}{I_{33}}, \quad \gamma = \frac{M_2}{I_{22}}, \quad (5.19.9)$$

so the only nonzero stress component is given by [see Eq. (5.19.4)]

$$T_{11} = \frac{M_2 x_3}{I_{22}} - \frac{M_3 x_2}{I_{33}}. \quad (5.19.10)$$

The stress component T_{11} is known as the *flexural stress*.

To investigate the nature of deformation due to bending moments, for simplicity we let $M_3 = 0$. The strain components are then

$$E_{11} = \frac{M_2 x_3}{I_{22} E_Y}, \quad E_{22} = E_{33} = -\frac{\nu M_2 x_3}{I_{22} E_Y}, \quad E_{12} = E_{13} = E_{23} = 0. \quad (5.19.11)$$

Using strain-displacement relations, $2E_{ij} = \partial u_i / \partial x_j + \partial u_j / \partial x_i$, Eqs. (5.19.11) can be integrated (we are assured that this is possible since the strains are compatible) to give the following displacement field:

$$\begin{aligned} u_1 &= \frac{M_2}{E_Y I_{22}} x_1 x_3 - \alpha_3 x_2 + \alpha_2 x_3 + \alpha_4, \\ u_2 &= -\frac{\nu M_2}{E_Y I_{22}} x_2 x_3 + \alpha_3 x_1 - \alpha_1 x_3 + \alpha_5, \\ u_3 &= -\frac{M_2}{2E_Y I_{22}} [x_1^2 - \nu(x_2^2 - x_3^2)] - \alpha_2 x_1 + \alpha_1 x_2 + \alpha_6, \end{aligned} \quad (5.19.12)$$

where α_i are constants. The terms that involve α_i , i.e.,

$$u_1 = -\alpha_3 x_2 + \alpha_2 x_3 + \alpha_4, \quad u_2 = \alpha_3 x_1 - \alpha_1 x_3 + \alpha_5, \quad u_3 = -\alpha_2 x_1 + \alpha_1 x_2 + \alpha_6 \quad (5.19.13)$$

describe a rigid body displacement field ($\nabla \mathbf{u}$ is antisymmetric).

Example 5.19.1

A beam is bent by end couples $\mathbf{M}_R = M\mathbf{e}_2$ at $x_1 = \ell$ and $\mathbf{M}_L = -\mathbf{M}_R$ at $x_1 = 0$. The \mathbf{e}_2 axis is perpendicular to the paper and pointing outward. The origin of the coordinate axes is at the centroid of the left end section with x_1 axis passing through the centroids of all the cross-sections to the right; x_2 and x_3 axes are the principal axes, with positive x_3 axis pointing downward. The beam is subjected to the following constraints: (i) The origin is fixed, (ii) $(\partial u_3 / \partial x_2) = 0$ at the origin and (iii) the centroid at the right end section can only move horizontally in x_1 - direction. (a) Obtain the displacement field and show that every plane cross-section remains a plane after bending and (b) obtain the deformed shape of the centroidal line of the beam, regarded as the deflection of the beam.

Solution

(a) From Eqs. (5.19.12), we have:

(i) At $(0, 0, 0)$, $u_1 = u_2 = u_3 = 0$. Thus, $\alpha_4 = \alpha_5 = \alpha_6 = 0$.

(ii) At $(0, 0, 0)$, $\partial u_3 / \partial x_2 = 0$. Thus, $\alpha_1 = 0$.

(iii) At $(\ell, 0, 0)$, $u_2 = u_3 = 0$. Thus, $\alpha_3 = 0$, $\alpha_2 = -M\ell / (2E_Y I_{22})$.

The displacement field is

$$\begin{aligned} u_1 &= \frac{Mx_3}{E_Y I_{22}} \left(x_1 - \frac{\ell}{2} \right), \\ u_2 &= -\frac{\nu M}{E_Y I_{22}} x_2 x_3, \\ u_3 &= \frac{Mx_1}{2E_Y I_{22}} (\ell - x_1) + \frac{M}{2E_Y I_{22}} \nu (x_2^2 - x_3^2). \end{aligned} \quad (5.19.14)$$

For a cross-section $x_1 = c$,

$$u_1 = \frac{M}{E_Y I_{22}} \left(c - \frac{\ell}{2} \right) x_3. \quad (5.19.15)$$

Thus, every plane cross-section remains a plane after bending. It simply rotates an angle given by

$$\theta \approx \tan \theta = \frac{du_1}{dx_3} = \frac{M}{E_Y I_{22}} \left(c - \frac{\ell}{2} \right). \quad (5.19.16)$$

In particular, the cross-section at the midspan ($c = \ell/2$) remains vertical, whereas the section at $x_1 = 0$ rotates an angle of $-M\ell / (E_Y I_{22})$ (clockwise) and the section at $x_1 = \ell$, of $M\ell / (E_Y I_{22})$ (counter-clockwise).

(b) For the centroidal axis $x_2 = x_3 = 0$, from the third equation in Eq. (5.19.14), we have

$$u_3 = \frac{Mx_1}{2E_Y I_{22}} (\ell - x_1). \quad (5.19.17)$$

This is conventionally taken as the deflection curve for the beam.

A.3 PLANE STRESS AND PLANE STRAIN SOLUTIONS

5.20 PLANE STRAIN SOLUTIONS

Consider a cylindrical body or a prismatic bar that has a uniform cross-section with its normal in the axial direction, which we take to be the x_3 axis. The cross-sections are perpendicular to the lateral surface and parallel to the $x_1 x_2$ plane. On its lateral surfaces, the surface tractions are also uniform with respect to the axial direction and have no axial (i.e., x_3) components. Its two end faces (e.g., $x_3 = \pm b$) are prevented from axial displacements but are free to move in other directions (e.g., constrained by frictionless planes). Under these conditions, the body is in a state of *plane strain*. That is,

$$E_{13} = E_{23} = E_{33} = 0, \quad E_{11} = E_{11}(x_1, x_2), \quad E_{22} = E_{22}(x_1, x_2), \quad E_{12} = E_{12}(x_1, x_2). \quad (5.20.1)$$

For this state of strain, the nonzero stress components are

$$T_{11} = T_{11}(x_1, x_2), \quad T_{22} = T_{22}(x_1, x_2), \quad T_{12} = T_{12}(x_1, x_2) = T_{21}, \quad (5.20.2)$$

and from Hooke's law, $0 = (1/E_Y)[T_{33} - \nu(T_{11} + T_{22})]$, we have

$$T_{33} = \nu(T_{11} + T_{22}). \quad (5.20.3)$$

We see that although the strain components exist only with reference to the x_1x_2 plane, the state of stress in general includes a nonzero $T_{33}(x_1, x_2)$. In fact, this component of stress is needed to maintain zero axial strain, and in general, removal of this axial stress from the end faces will not only result in axial deformation but also alter the stress and strain field in the bar, except when T_{33} is a linear function of x_1 and x_2 , in which case it can be removed entirely from the bar without affecting the other stress components, although the strain field will be affected (see Example 5.20.1). However, if the cylinder is long (in x_3 -direction), then by St. Venant's principle, the stress field in regions far from the end faces, due to T_{33} acting alone on the end faces, can be obtained by replacing the surface traction with an equivalent force system, which allows for easy calculations of the stress field. For example, if the resultant of $T_{33}(x_1, x_2)$ on the end face is a force P passing through the centroid of the cross-section, then the effect of the axial traction T_{33} is simply that of a uniform axial stress P/A in regions far from the end faces. In this case the axial traction on the end faces can be simply removed from the end faces without affecting the in-plane stress components T_{11} , T_{22} and T_{12} ; only $T_{33}(x_1, x_2)$ in the bar needs to be modified. This is true in general. Thus, as far as in-plane stress components are concerned (i.e., T_{11} , T_{22} and T_{12}), the plane strain solution is good for two kinds of problems: (a) a cylinder whose end faces are constrained from axial displacements, in this case, $T_{33} = \nu(T_{11} + T_{22})$ throughout the bar, and in this case, the solution is exact, and (b) a long cylinder whose end faces are free from surface traction; in this case, the axial stress $T_{33} \neq \nu(T_{11} + T_{22})$, but its approximate values can be obtained using St. Venant's principle and the principle of superposition.* The two problems have the same in-plane stress components in reference to the x_1x_2 plane. These in-plane stresses are what we are concerned with in this so-called plane strain solutions.

We should note that plane strain problems can also be defined as those whose displacement field is

$$u_1 = u_1(x_1, x_2), \quad u_2 = u_2(x_1, x_2), \quad u_3 = 0 \text{ (or a constant)}. \quad (5.20.4)$$

We now consider a static stress field associated with a plane strain problem. In the absence of body forces, the equilibrium equations reduce to

$$\frac{\partial T_{11}}{\partial x_1} + \frac{\partial T_{12}}{\partial x_2} = 0, \quad \frac{\partial T_{21}}{\partial x_1} + \frac{\partial T_{22}}{\partial x_2} = 0, \quad \frac{\partial T_{33}}{\partial x_3} = 0. \quad (5.20.5)$$

Because T_{33} depends only on (x_1, x_2) , the last equation in Eq. (5.20.5) is trivially satisfied. It can be easily verified that the other two equations of equilibrium in Eq. (5.20.5) are satisfied for the stress components calculated from the following equations for any scalar function $\varphi(x_1, x_2)$, known as the *Airy stress function*:

$$T_{11} = \frac{\partial^2 \varphi}{\partial x_2^2}, \quad T_{12} = -\frac{\partial^2 \varphi}{\partial x_1 \partial x_2}, \quad T_{22} = \frac{\partial^2 \varphi}{\partial x_1^2}. \quad (5.20.6)$$

*Superposing $\nu(T_{11} + T_{22})$ with the stress, obtained via the St. Venant principle, due to normal surface traction of $-\nu(T_{11} + T_{22})$ on the end faces.

However, not all stress components obtained this way are acceptable as possible elastic solutions, because the strain components derived from them may not be compatible; that is, there may not exist displacement components that correspond to the strain components. To ensure the compatibility of the strain components, we first obtain the strain components in terms of ϕ as follows:

$$\begin{aligned} E_{11} &= \frac{1}{E_Y} [T_{11} - \nu\{T_{22} + \nu(T_{11} + T_{22})\}] = \frac{1}{E_Y} \left[(1 - \nu^2) \frac{\partial^2 \phi}{\partial x_2^2} - \nu(1 + \nu) \frac{\partial^2 \phi}{\partial x_1^2} \right], \\ E_{22} &= \frac{1}{E_Y} [T_{22} - \nu\{\nu(T_{11} + T_{22}) + T_{11}\}] = \frac{1}{E_Y} \left[(1 - \nu^2) \frac{\partial^2 \phi}{\partial x_1^2} - \nu(1 + \nu) \frac{\partial^2 \phi}{\partial x_2^2} \right], \\ E_{12} &= \frac{1}{E_Y} (1 + \nu) T_{12} = -\frac{1}{E_Y} (1 + \nu) \frac{\partial^2 \phi}{\partial x_1 \partial x_2}, \quad E_{13} = E_{23} = E_{33} = 0. \end{aligned} \quad (5.20.7)$$

For plane strain problems, the only compatibility equation that is not automatically satisfied is

$$\frac{\partial^2 E_{11}}{\partial x_2^2} + \frac{\partial^2 E_{22}}{\partial x_1^2} = 2 \frac{\partial^2 E_{12}}{\partial x_1 \partial x_2}. \quad (5.20.8)$$

Substitution of Eqs. (5.20.7) into Eq. (5.20.8) results in (see Prob. 5.61)

$$\nabla^4 \phi = \frac{\partial^4 \phi}{\partial x_1^4} + 2 \frac{\partial^4 \phi}{\partial x_1^2 \partial x_2^2} + \frac{\partial^4 \phi}{\partial x_2^4} = 0. \quad (5.20.9)$$

Any function $\phi(x_1, x_2)$ that satisfies this biharmonic equation, Eq. (5.20.9), generates a possible elastostatic solution. It can also be easily obtained that

$$\left(\frac{\partial^2}{\partial x_1^2} + \frac{\partial^2}{\partial x_2^2} \right) (T_{11} + T_{22}) = \frac{\partial^4 \phi}{\partial x_1^4} + \frac{\partial^4 \phi}{\partial x_2^4} + 2 \frac{\partial^4 \phi}{\partial x_1^2 \partial x_2^2} = 0, \quad (5.20.10)$$

which may be written as

$$\nabla^2 (T_{11} + T_{22}) = 0 \quad \text{where} \quad \nabla^2 \equiv \left(\frac{\partial^2}{\partial x_1^2} + \frac{\partial^2}{\partial x_2^2} \right). \quad (5.20.11)$$

Example 5.20.1

Consider the following state of stress in a cylindrical body with x_3 axis normal to its cross-sections:

$$[\mathbf{T}] = \begin{bmatrix} 0 & 0 & 0 \\ 0 & 0 & 0 \\ 0 & 0 & T_{33}(x_1, x_2) \end{bmatrix}. \quad (5.20.12)$$

Show that the most general form of $T_{33}(x_1, x_2)$, which gives rise to a possible state of stress in the body in the absence of body force, is

$$T_{33}(x_1, x_2) = \alpha x_1 + \beta x_2 + \gamma. \quad (5.20.13)$$

Solution

The strain components are

$$E_{11} = -\frac{\nu T_{33}(x_1, x_2)}{E_Y} = E_{22}, \quad E_{33} = \frac{T_{33}(x_1, x_2)}{E_Y}, \quad E_{12} = E_{13} = E_{23} = 0. \quad (5.20.14)$$

Substituting the preceding into the compatibility equations (Section 3.16), we obtain

$$\frac{\partial^2 T_{33}}{\partial x_1^2} = 0, \quad \frac{\partial^2 T_{33}}{\partial x_2^2} = 0, \quad \frac{\partial^2 T_{33}}{\partial x_1 \partial x_2} = 0. \quad (5.20.15)$$

Thus, for the given stress tensor to be a possible elastic state of stress, $T_{33}(x_1, x_2)$ must be a linear function of x_1 and x_2 . That is,

$$T_{33} = \alpha x_1 + \beta x_2 + \gamma. \quad (5.20.16)$$

From this result, we see that if a cylindrical body is loaded on its end faces by equal and opposite normal traction distribution T_{33} , which is a linear function of x_1 and x_2 , then the stress field inside the body is given by the same T_{33} throughout the whole body, with no other stress components (this includes the case of simple extension where $T_{33} = \sigma$, considered in Section 5.13 and the case of pure bending considered in Section 5.19). On the other hand, if the normal traction on the end faces is not a linear function of x_1 and x_2 , then the stress distribution inside the body is not given by Eq. (5.20.12).

5.21 RECTANGULAR BEAM BENT BY END COUPLES

Consider a rectangular beam whose length is defined by $x_1 = 0$ and $x_1 = \ell$, whose height by $x_2 = \pm h/2$, and whose width by $x_3 = \pm b/2$. Let us try the following Airy stress function φ for this beam:

$$\varphi = \alpha x_2^3 \quad (5.21.1)$$

Clearly, this function satisfies the biharmonic equation, Eq. (5.20.9), so that it will generate a possible elastic solution. Substituting Eq. (5.21.1) into Eqs. (5.20.6), we obtain

$$T_{11} = \frac{\partial^2 \varphi}{\partial x_2^2} = 6\alpha x_2, \quad T_{12} = -\frac{\partial^2 \varphi}{\partial x_1 \partial x_2} = 0, \quad T_{22} = \frac{\partial^2 \varphi}{\partial x_1^2} = 0. \quad (5.21.2)$$

(a) If the beam is constrained by frictionless walls at $x_3 = \pm b/2$, then

$$T_{33} = \nu(T_{11} + T_{22}) = 6\nu\alpha x_2, \quad (5.21.3)$$

and the stresses in the beam are given by

$$[\mathbf{T}] = \begin{bmatrix} 6\alpha x_2 & 0 & 0 \\ 0 & 0 & 0 \\ 0 & 0 & 6\nu\alpha x_2 \end{bmatrix}. \quad (5.21.4)$$

On the end faces $x_1 = 0$ and $x_1 = \ell$, the surface tractions are given by $\mathbf{t} = -6\alpha x_2 \mathbf{e}_1$ and $\mathbf{t} = 6\alpha x_2 \mathbf{e}_1$, respectively. These surface tractions are clearly equivalent to equal and opposite bending couples at $x_1 = 0$ and $x_1 = \ell$. In fact, the magnitude of the bending moment is given by

$$M = 6\alpha \int_{-h/2}^{h/2} x_2(x_2 b dx_2) = \alpha b h^3 / 2, \quad (5.21.5)$$

so that in terms of M , the nonzero stress components are

$$T_{11} = 6\alpha x_2 = \frac{12M}{bh^3}x_2, \quad T_{33} = \nu \frac{12M}{bh^3}x_2. \quad (5.21.6)$$

- (b) If the beam is unconstrained at $x_3 = \pm b/2$, we need to remove the surface traction T_{33} at $x_3 = \pm b/2$ from the beam. This is done by applying on the end faces $x_3 = \pm b/2$ in the problem of part (a), a surface traction $T_{33} = -\nu(12M/bh^3)x_2$. Being linear in x_2 , the effect of this surface traction is simply a stress field, where $T_{33} = -\nu(12M/bh^3)x_2$ is the only nonzero stress component (see Example 5.20.1). Thus, we have, for the beam that is free to move in the width x_3 - direction,

$$T_{11} = \left(\frac{12M}{bh^3}\right)x_2 = \frac{Mx_2}{I_{33}}, \quad \text{all other } T_{ij} = 0. \quad (5.21.7)$$

This is the same result that we obtained earlier in Section 5.19. We note that the x_2 axis here corresponds to the x_3 axis in that section.

5.22 PLANE STRESS PROBLEM

Consider a very thin disc or plate, circular or otherwise, its faces perpendicular to the x_3 -axis, its lateral surface (often referred to as the *edge* of the disc) subjected to tractions that are (or may be considered to be, since the disc is thin) independent of x_3 (i.e., uniform in the thin axial direction) and its two end faces are free from any surface traction. Then the disc is approximately in a state of *plane stress*. That is,

$$[\mathbf{T}] = \begin{bmatrix} T_{11}(x_1, x_2) & T_{12}(x_1, x_2) & 0 \\ T_{12}(x_1, x_2) & T_{22}(x_1, x_2) & 0 \\ 0 & 0 & 0 \end{bmatrix}. \quad (5.22.1)$$

This assumption is based on the fact that, on the two end faces $T_{13} = T_{23} = T_{33} = 0$, so that within the disc, it being very thin, these components of stress will also be very close to zero. That the plane stress assumption, in general, does not lead to a possible elastic solution (except in special cases) will be shown here by establishing that Eq. (5.22.1) in general does not satisfy all the compatibility equations. However, it can be shown that the errors committed in the stress components in Eq. (5.22.1) are of the order of ε^2 , where ε is some dimensionless thickness of the plate, such as the ratio of the thickness to the radius, so that it is a good approximation for thin plates (see Timoshenko and Goodier, *Theory of Elasticity*, third edition, McGraw-Hill, pp. 274–276).

The equations of equilibrium can be assured if we again introduce the Airy stress function, which is repeated here:

$$T_{11} = \frac{\partial^2 \varphi}{\partial x_2^2}, \quad T_{12} = -\frac{\partial^2 \varphi}{\partial x_1 \partial x_2}, \quad T_{22} = \frac{\partial^2 \varphi}{\partial x_1^2}. \quad (5.22.2)$$

Corresponding to this state of plane stress, the strain components are

$$\begin{aligned} E_{11} &= \frac{1}{E_Y}(T_{11} - \nu T_{22}) = \frac{1}{E_Y} \left(\frac{\partial^2 \varphi}{\partial x_2^2} - \nu \frac{\partial^2 \varphi}{\partial x_1^2} \right), & E_{22} &= \frac{1}{E_Y}(T_{22} - \nu T_{11}) = \frac{1}{E_Y} \left(\frac{\partial^2 \varphi}{\partial x_1^2} - \nu \frac{\partial^2 \varphi}{\partial x_2^2} \right) \\ E_{33} &= -\frac{\nu}{E_Y}(T_{11} + T_{22}) = -\frac{\nu}{E_Y} \left(\frac{\partial^2 \varphi}{\partial x_2^2} + \frac{\partial^2 \varphi}{\partial x_1^2} \right), & E_{12} &= \frac{1}{E_Y}(1 + \nu)T_{12} = -\frac{1}{E_Y}(1 + \nu) \frac{\partial^2 \varphi}{\partial x_1 \partial x_2}. \\ E_{13} &= E_{23} = 0. \end{aligned} \quad (5.22.3)$$

In order that these strains are compatible, they must satisfy the six compatibility equations derived in Section 3.16. The consequences are:

- Equation (3.16.7) leads to

$$\frac{\partial^4 \varphi}{\partial x_1^4} + 2 \frac{\partial^4 \varphi}{\partial x_1^2 \partial x_2^2} + \frac{\partial^4 \varphi}{\partial x_2^4} = 0 \quad (5.22.4)$$

(see Prob. 5.62).

- Equations (3.16.8), (3.16.9), and (3.16.12) lead to

$$\frac{\partial^2 E_{33}}{\partial x_1^2} = 0, \quad \frac{\partial^2 E_{33}}{\partial x_2^2} \quad \text{and} \quad \frac{\partial^2 E_{33}}{\partial x_1 \partial x_2} = 0. \quad (5.22.5)$$

Thus, E_{33} must be a linear function of x_1 and x_2 . Since $E_{33} = -(v/E_Y)(T_{11} + T_{22})$; $T_{11} + T_{22}$ must be a linear function of x_1 and x_2 .

- The other two equations are identically satisfied.

Thus, a plane stress solution, in reference to (x_1, x_2) , is in general *not* a possible state of stress in a cylindrical/prismatic body (with cross-sections perpendicular to the x_3 -axis). However, (a) if $(T_{11} + T_{22})$ is a linear function of x_1 and x_2 , then the plane stress is a possible state of stress for a body of any width (in x_3 direction) and (b) if $(T_{11} + T_{22})$ is not a linear function of x_1 and x_2 , then the state of plane stress can be regarded as a good approximate solution if the body is very thin (in x_3 direction), the errors are of the order of ε^2 , where ε is some dimensionless thickness of the disc/plate.

5.23 CANTILEVER BEAM WITH END LOAD

Consider a rectangular beam, whose cross-section is defined by $-h/2 \leq x_2 \leq h/2$ and $-b/2 \leq x_3 \leq b/2$ and whose length, by $0 \leq x_1 \leq \ell$, with the origin of the coordinates located at the center of the left cross-section $x_1 = 0$ (Figure 5.23-1). Let us try the following Airy stress function φ for this beam.

$$\varphi = \alpha x_1 x_2^3 + \beta x_1 x_2. \quad (5.23.1)$$

Clearly, this satisfies the biharmonic equation Eq. (5.20.9). The in-plane stresses are

$$T_{11} = \frac{\partial^2 \varphi}{\partial x_2^2} = 6\alpha x_1 x_2, \quad T_{22} = \frac{\partial^2 \varphi}{\partial x_1^2} = 0, \quad T_{12} = -\frac{\partial^2 \varphi}{\partial x_1 \partial x_2} = -\beta - 3\alpha x_2^2. \quad (5.23.2)$$

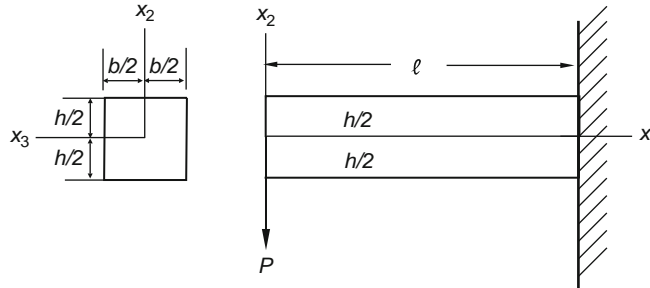

FIGURE 5.23-1

On the boundary planes $x_2 = \pm h/2$, we demand that they are traction-free. Thus,

$$\mathbf{t} = \mathbf{T}(\pm \mathbf{e}_2) = \pm(T_{12}\mathbf{e}_1 + T_{22}\mathbf{e}_2)|_{x_2=\pm h/2} = \pm(-\beta - \frac{3\alpha h^2}{4})\mathbf{e}_1 = 0, \quad (5.23.3)$$

from which we have

$$\beta = -\frac{3h^2}{4}\alpha. \quad (5.23.4)$$

On the boundary plane $x_1 = 0$, the surface traction is given by

$$\mathbf{t} = -\mathbf{T}\mathbf{e}_1 = -(T_{11}\mathbf{e}_1 + T_{21}\mathbf{e}_2)_{x_1=0} = (\beta + 3\alpha x_2^2)\mathbf{e}_2 = \frac{3\alpha}{4}(-h^2 + 4x_2^2)\mathbf{e}_2. \quad (5.23.5)$$

That is, there is a parabolic distribution of shear stress on the end face $x_1 = 0$. Let the resultant of this distribution be denoted by $-P\mathbf{e}_2$ (the minus sign indicates downward force, as shown in Figure 5.23-1); then

$$-P = \left(-\frac{3\alpha h^2}{4}\right) \int dA + 3\alpha \int_{-h/2}^{h/2} x_2^2 (bdx_2) = \left(-\frac{3\alpha h^2}{4}\right)(bh) + 3\alpha \frac{bh^3}{12}. \quad (5.23.6)$$

Thus,

$$P = \left(\frac{bh^3}{2}\right)\alpha, \quad \alpha = \frac{2P}{bh^3}, \quad \text{and} \quad \beta = -\frac{3P}{2bh}. \quad (5.23.7)$$

In terms of P , the in-plane stress components are

$$T_{11} = \frac{12P}{bh^3}x_1x_2 = \frac{P}{I}x_1x_2, \quad T_{22} = 0, \quad T_{12} = \left(\frac{P}{2I}\right)\left(\frac{h^2}{4} - x_2^2\right), \quad (5.23.8)$$

where $I = bh^3/12$ is the second moment of the cross-section. If the beam is in a plane strain condition, there will be normal compressive stresses on the boundary $x_3 = \pm b/2$ whose magnitude is given by

$$T_{33} = \nu(T_{11} + T_{22}) = \nu \frac{12P}{bh^3}x_1x_2. \quad (5.23.9)$$

That is,

$$[\mathbf{T}] = \begin{bmatrix} T_{12} & T_{12} & 0 \\ T_{12} & T_{22} & 0 \\ 0 & 0 & T_{33} \end{bmatrix}, \quad [\mathbf{E}] = \begin{bmatrix} E_{11} & E_{12} & 0 \\ E_{12} & E_{22} & 0 \\ 0 & 0 & 0 \end{bmatrix}, \quad (5.23.10)$$

where the nonzero stress components are given by Eqs. (5.23.8) and (5.23.9). The nonzero strain components are

$$\begin{aligned} E_{11} &= \frac{1}{E_Y} [T_{11}(1 - \nu^2) - \nu(1 + \nu)T_{22}], \\ E_{22} &= \frac{1}{E_Y} [T_{22}(1 - \nu^2) - \nu(1 + \nu)T_{11}], \\ E_{12} &= \frac{1}{E_Y} (1 + \nu)T_{12}. \end{aligned} \quad (5.23.11)$$

This plane strain solution, Eq. (5.23.10), is valid for the beam with any width b .

Since T_{33} in Eq. (5.23.9) is *not* a linear function of x_1 and x_2 , it cannot be simply removed from Eq. (5.23.10) to give a plane stress solution without affecting the other stress components (see Example 5.20.1). However, if the beam is very thin (i.e., very small b compared with the other dimensions), then a good approximate solution for the beam is

$$[\mathbf{T}] = \begin{bmatrix} T_{12} & T_{12} & 0 \\ T_{12} & T_{22} & 0 \\ 0 & 0 & 0 \end{bmatrix}, \quad [\mathbf{E}] = \begin{bmatrix} E_{11} & E_{12} & 0 \\ E_{12} & E_{22} & 0 \\ 0 & 0 & E_{33} \end{bmatrix}, \quad (5.23.12)$$

where the nonzero stress components are given by Eq. (5.23.8) and the nonzero strain components are

$$E_{11} = \frac{1}{E_Y}(T_{11} - \nu T_{22}), \quad E_{22} = \frac{1}{E_Y}(T_{22} - \nu T_{11}), \quad E_{12} = \frac{1}{E_Y}(1 + \nu)T_{12}, \quad (5.23.13)$$

and $E_{33} = -(\nu/E_Y)(T_{11} + T_{22})$. The strain E_{33} is of no interest since the plate is very thin and the compatibility conditions involving E_{33} are not satisfied.

In the following example, we discuss the displacement field for this beam and prescribe the following displacement boundary condition for the right end of the beam:

$$u_1 = u_2 = \frac{\partial u_2}{\partial x_1} = 0, \quad \text{at } (x_1, x_2) = (\ell, 0).$$

These displacement boundary conditions demand that, at the right end of the beam, the centroidal plane $x_2 = 0$ is perpendicular to the wall while fixed at the wall. These conditions correspond partially to the condition of a complete fixed wall.

Example 5.23.1

- (a) For the cantilever beam discussed in this section, verify that the in-plane displacement field for the beam in plane stress condition is given by the following:

$$\begin{aligned} u_1 &= \frac{Px_1^2 x_2}{2E_Y l} + \frac{\nu Px_2^3}{6E_Y l} - \frac{Px_2^3}{6\mu l} + \frac{Px_2}{2\mu l} \left(\frac{h}{2}\right)^2 + b_1 x_2 + c_2, \\ u_2 &= -\frac{\nu Px_1 x_2^2}{2E_Y l} - \frac{Px_1^3}{6E_Y l} - b_1 x_1 + c_3. \end{aligned} \quad (i)$$

- (b) If we demand that, at the point $(x_1, x_2) = (\ell, 0)$, $u_1 = u_2 = \partial u_2 / \partial x_1 = 0$, obtain the deflection curve for the beam, i.e., obtain $u_2(x_1, 0)$.

Solution

- (a) For plane stress condition, we have

$$\begin{aligned} E_{11} &= \frac{1}{E_Y}(T_{11} - \nu T_{22}) = \frac{Px_1 x_2}{E_Y l}, \quad E_{22} = \frac{1}{E_Y}(T_{22} - \nu T_{11}) = -\frac{\nu Px_1 x_2}{E_Y l}, \\ E_{12} &= \frac{(1 + \nu)}{E_Y} T_{12} = \left(\frac{P}{4l\mu}\right) \left(\frac{h^2}{4} - x_2^2\right). \end{aligned} \quad (ii)$$

From the given displacement field, i.e., Eq. (i), we obtain

$$\begin{aligned}
 E_{11} &= \frac{\partial u_1}{\partial x_1} = \frac{Px_1x_2}{E_YI}, & E_{22} &= \frac{\partial u_2}{\partial x_2} = -\frac{\nu Px_1x_2}{E_YI}, \\
 E_{12} &= \frac{1}{2} \left(\frac{\partial u_1}{\partial x_2} + \frac{\partial u_2}{\partial x_1} \right) = \frac{1}{2} \left\{ \frac{Px_1^2}{2E_YI} + \frac{\nu Px_2^2}{2E_YI} - \frac{Px_2^2}{2\mu l} + \frac{P}{2\mu l} \left(\frac{h}{2} \right)^2 + b_1 \right\} \\
 &\quad + \frac{1}{2} \left\{ -\frac{\nu Px_2^2}{2E_YI} - \frac{Px_1^2}{2E_YI} - b_1 \right\} = -\frac{Px_2^2}{4\mu l} + \frac{P}{4\mu l} \left(\frac{h}{2} \right)^2 = \left(\frac{P}{4\mu l} \right) \left(\frac{h^2}{4} - x_2^2 \right).
 \end{aligned} \tag{iii}$$

Comparing Eqs. (iii) with Eqs. (ii), we see that the given displacement field is indeed the in-plane displacement field for the beam.

We remark that the displacement u_1 is not a linear function of x_2 for any cross-section ($x_1 = \text{constant}$); therefore, a cross-sectional plane does not remain a plane after bending. Also, we note that u_3 cannot be found (does not exist), because under the plane stress assumption, the compatibility conditions involving E_{33} are not satisfied.

(b) From $u_2(\ell, 0) = 0$ and $\frac{\partial u_2}{\partial x_1}(\ell, 0) = 0$, we have

$$-\frac{P\ell^3}{6E_YI} - b_1\ell + c_3 = 0 \quad \text{and} \quad -\frac{P\ell^2}{2E_YI} - b_1 = 0,$$

thus, $b_1 = -P\ell^2/(2E_YI)$, $c_3 = -P\ell^3/(3E_YI)$, and the deflection curve is

$$u_2(x_1, 0) = -\frac{Px_1^3}{6E_YI} + \frac{P\ell^2x_1}{2E_YI} - \frac{P\ell^3}{3E_YI}. \tag{iv}$$

At the free end, the deflection is $u_2(0, 0) = -\frac{P\ell^3}{3E_YI}$, a very well-known result in elementary strength of materials.

5.24 SIMPLY SUPPORTED BEAM UNDER UNIFORM LOAD

Consider a rectangular beam, its length defined by $-\ell \leq x_1 \leq \ell$, its height by $-d \leq x_2 \leq d$, and its width by $-b \leq x_3 \leq b$. The origin of the coordinates is at the center of the beam. Let us try the following Airy stress function φ for this beam,

$$\varphi = B_0x_1^2 + B_1x_1^2x_2 + B_2x_2^3 + B_3x_1^2x_2^3 + B_4x_2^5. \tag{5.24.1}$$

Substituting the preceding equation in the biharmonic equation, we get

$$\frac{\partial^4 \varphi}{\partial x_1^4} + 2 \frac{\partial^4 \varphi}{\partial x_1^2 \partial x_2^2} + \frac{\partial^4 \varphi}{\partial x_2^4} = 0 + 24B_3x_2 + 120B_4x_2 = 0, \quad \text{so that } B_4 = -B_3/5.$$

Thus,

$$\varphi = B_0 x_1^2 + B_1 x_1^2 x_2 + B_2 x_2^3 + B_3 (x_1^2 x_2^3 - x_2^5/5). \quad (5.24.2)$$

The stress components are

$$\begin{aligned} T_{11} &= \partial^2 \varphi / \partial x_2^2 = 6B_2 x_2 + B_3 (6x_1^2 x_2 - 4x_2^3), \\ T_{22} &= \partial^2 \varphi / \partial x_1^2 = 2B_0 + 2B_1 x_2 + 2B_3 x_2^3, \\ T_{12} &= -\partial^2 \varphi / \partial x_1 \partial x_2 = -2B_1 x_1 - 6B_3 x_1 x_2^2. \end{aligned} \quad (5.24.3)$$

Let the bottom of the beam be free of any traction. That is, at $x_2 = -d$, $T_{12} = T_{22} = 0$. Then

$$2B_0 - 2B_1 d - 2B_3 d^3 = 0 \quad \text{and} \quad -2B_1 x_1 - 6B_3 x_1 d^2 = 0, \quad \text{so that } B_1 = -3d^2 B_3, \quad B_0 = -2B_3 d^3. \quad (5.24.4)$$

Let the top face of the beam be under a uniform compressive load $-p$. That is, at $x_2 = +d$, $T_{12} = 0$, $T_{22} = -p$, then, $2B_0 + 2B_1 d + 2B_3 d^3 = -p$.

Thus,

$$B_3 = \frac{p}{8d^3}, \quad B_1 = -\frac{3p}{8d}, \quad B_0 = -\frac{p}{4}. \quad (5.24.5)$$

On the left and right end faces, we will impose the conditions that the surface tractions on each face are equivalent to a vertical resultant force only, with no resultant force in the direction normal to the faces, i.e., the x_1 -direction and no resultant couple. These are known as the *weak conditions* for the beam, which is free from normal stresses at $x_1 = \pm \ell$ [i.e., $(T_{11})_{x_1 = \pm \ell} = 0$]. For a beam with large ℓ/d (a long beam), the stresses obtained under the weak conditions are the same as those under the conditions $(T_{11})_{x_1 = \pm \ell} = 0$, except near the end faces in accordance with the St. Venant's principle.

Equation (5.24.3) shows that T_{11} is an odd function of x_2 ; therefore, $\int_{-d}^d T_{11}(2b) dx_2 = 0$. That is, the resultant force is zero on both ends. We now impose the condition that there are no resultant couples, either. That is, we require that $\int_{-d}^d T_{11} x_2 dx_2 = 0$. Now,

$$\begin{aligned} \int_{-d}^d T_{11} x_2 dx_2 &= \int_{-d}^d [6B_2 x_2^2 + B_3 (6x_1^2 x_2^2 - 4x_2^4)]_{x_1 = \pm \ell} dx_2 \\ &= 4B_2 d^3 + B_3 \left(4\ell^2 d^3 - \frac{8d^5}{5} \right) = 0. \end{aligned}$$

Thus,

$$B_2 = -\frac{B_3}{5} (5\ell^2 - 2d^2) = -\frac{p}{40d^3} (5\ell^2 - 2d^2). \quad (5.24.6)$$

Using Eq. (5.24.5) and (5.24.6), we have

$$\begin{aligned} T_{11} &= -\frac{3p}{20d^3} (5\ell^2 - 2d^2) x_2 + \frac{p}{8d^3} (6x_1^2 x_2 - 4x_2^3), \\ T_{12} &= \frac{3p}{4d} x_1 - \frac{3p}{4d^3} x_1 x_2^2, \\ T_{22} &= -\frac{p}{2} - \frac{3p}{4d} x_2 + \frac{p}{4d^3} x_2^3. \end{aligned} \quad (5.24.7)$$

5.25 SLENDER BAR UNDER CONCENTRATED FORCES AND ST. VENANT'S PRINCIPLE

Consider a thin bar defined by $-\ell \leq x_1 \leq \ell$, $-c \leq x_2 \leq c$, $-b \leq x_3 \leq b$ (Figure 5.25-1) where c/ℓ and b/ℓ are very small. The bar is acted on by equal and opposite compressive concentrated load P at the long ends $x_1 = \pm\ell$. We wish to determine the stress distribution inside the bar and to demonstrate the validity of St. Venant's principle.

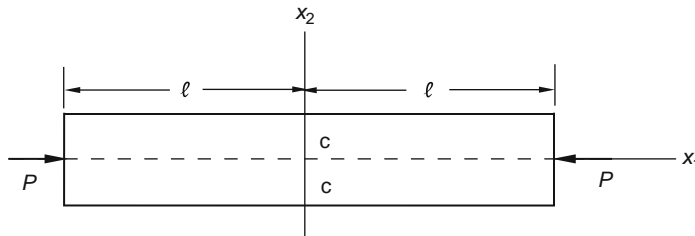

FIGURE 5.25-1

A concentrated line compressive force P (per unit length in x_3 direction) at $x_2 = 0$ on the planes $x_1 = \pm\ell$ can be described as $T_{11}(\pm\ell, 0) = -P\delta(0)$, where $T_{11} = T_{11}(x_1, x_2)$ and $\delta(x_2)$ is the Dirac function, having the dimension of reciprocal length. Now, $\delta(x_2)$ can be expressed as a Fourier Cosine series as

$$\delta(x_2) = \left[\frac{1}{2c} + \frac{1}{c} \sum_{m=1}^{\infty} \cos \lambda_m x_2 \right], \quad \lambda_m = m\pi/c, \quad (5.25.1)$$

so that

$$-P\delta(x_2) = - \left[\frac{P}{2c} + \frac{P}{c} \sum_{m=1}^{\infty} \cos \lambda_m x_2 \right]. \quad (5.25.2)$$

Thus, we look for solutions of the Airy stress function $\varphi(x_1, x_2)$ in the form of

$$\varphi = -\frac{P}{4c} x_2^2 + \sum_{m=1}^{\infty} \varphi_m(x_1) \cos \lambda_m x_2, \quad \lambda_m = m\pi/c, \quad (5.25.3)$$

so that

$$T_{11} = \frac{\partial^2 \varphi}{\partial x_2^2} = -\frac{P}{2c} - \sum_{m=1}^{\infty} \lambda_m^2 \varphi_m(x_1) \cos \lambda_m x_2. \quad (5.25.4)$$

The function $\varphi_m(x_2)$ will now be determined so that the biharmonic equation is satisfied. Substituting Eqs. (5.25.3) into the biharmonic equation, we get

$$\nabla^4 \varphi = \sum_{m=1}^{\infty} \left\{ \lambda_m^4 \varphi_m - 2\lambda_m^2 \frac{d^2 \varphi_m}{dx_1^2} + \frac{d^4 \varphi_m}{dx_1^4} \right\} \cos \lambda_m x_2 = 0.$$

Thus, $\lambda_m^4 \varphi_m - 2\lambda_m^2 \frac{d^2 \varphi_m}{dx_1^2} + \frac{d^4 \varphi_m}{dx_1^4} = 0$. The solution of this ordinary differential equation that is an even function of x_1 , is easily obtained to be

$$\varphi_m(x_1) = B_1 \cosh \lambda_m x_1 + B_2 x_1 \sinh \lambda_m x_1. \quad (5.25.5)$$

Thus,

$$\varphi = -\frac{P}{4c} x_2^2 + \sum_{m=1}^{\infty} (B_1 \cosh \lambda_m x_1 + B_2 x_1 \sinh \lambda_m x_1) \cos \lambda_m x_2, \quad \lambda_m = m\pi/c. \quad (5.25.6)$$

The stress components generated by this Airy stress function are

$$T_{11} = \frac{\partial^2 \varphi}{\partial x_2^2} = -\frac{P}{2c} - \sum_{m=1}^{\infty} \lambda_m^2 (B_1 \cosh \lambda_m x_1 + B_2 x_1 \sinh \lambda_m x_1) \cos \lambda_m x_2, \quad (5.25.7)$$

$$T_{22} = \frac{\partial^2 \varphi}{\partial x_1^2} = \sum_{m=1}^{\infty} \{B_1 \lambda_m^2 \cosh \lambda_m x_1 + B_2 \lambda_m (2 \cosh \lambda_m x_1 + \lambda_m x_1 \sinh \lambda_m x_1)\} \cos \lambda_m x_2, \quad (5.25.8)$$

$$T_{12} = -\frac{\partial^2 \varphi}{\partial x_1 \partial x_2} = \sum_{m=1}^{\infty} (\lambda_m) \{B_1 \lambda_m \sinh \lambda_m x_1 + B_2 (\sinh \lambda_m x_1 + \lambda_m x_1 \cosh \lambda_m x_1)\} \sin \lambda_m x_2. \quad (5.25.9)$$

On the boundaries $x_1 = \pm \ell$, there are compressive line concentrated forces P applied at $x_2 = 0$ but otherwise free from any other surface tractions. Thus, we demand

$$(T_{12})_{x_1=\pm\ell} = 0 = B_1 \lambda_m \sinh \lambda_m \ell + B_2 (\sinh \lambda_m \ell + \lambda_m \ell \cosh \lambda_m \ell), \quad (5.25.10)$$

and

$$(T_{11})_{x_1=\pm\ell} = -P\delta(x_2) = -\frac{P}{2c} - \sum_{m=1}^{\infty} \lambda_m^2 (B_1 \cosh \lambda_m \ell + B_2 \ell \sinh \lambda_m \ell) \cos \lambda_m x_2. \quad (5.25.11)$$

Now [see Eq. (5.25.2)],

$$-P\delta(x_2) = -\frac{P}{2c} - \frac{P}{c} \sum_{m=1}^{\infty} \cos \lambda_m x_2.$$

Thus,

$$B_1 \cosh \lambda_m \ell + B_2 \ell \sinh \lambda_m \ell = \frac{P}{c \lambda_m^2}. \quad (5.25.12)$$

Equations (5.25.10) and (5.25.12) give, with $\lambda_m = m\pi/c$,

$$B_1 = \left(\frac{2P}{c}\right) \frac{(\sinh \lambda_m \ell + \lambda_m \ell \cosh \lambda_m \ell)}{\lambda_m^2 \{\sinh 2\lambda_m \ell + 2\lambda_m \ell\}}, \quad B_2 = -\left(\frac{2P}{c}\right) \frac{\sinh \lambda_m \ell}{\lambda_m (\sinh 2\lambda_m \ell + 2\lambda_m \ell)}. \quad (5.25.13)$$

The surface tractions on the boundaries $x_2 = \pm c$ (top and bottom surfaces in the preceding figure) can be obtained from Eq. (5.25.9) as

$$(T_{12})_{x_2=\pm c} = 0, \quad (5.25.14)$$

and

$$(T_{22})_{x_2=\pm c} = \sum_{m=1}^{\infty} \{B_1 \lambda_m^2 \cosh \lambda_m x_1 + B_2 \lambda_m (2 \cosh \lambda_m x_1 + \lambda_m x_1 \sinh \lambda_m x_1)\} (-1)^m. \quad (5.25.15)$$

We see from Eq. (5.25.15) that there are equal and opposite normal tractions T_{22} acting on the faces $x_2 = c$ and $x_2 = -c$. However, if $c/\ell \rightarrow 0$ (that is, the bar is very thin in the x_2 direction), then these surface tractions (i.e., T_{22}) can be simply removed from the bar to give the state of stress inside the thin bar that is free from surface traction on these two faces and with $T_{22} = 0$ throughout the whole bar. We have also assumed that $b/\ell \rightarrow 0$ (that is, the bar is also very thin in the x_3 direction) so that we also have $T_{33} = 0$ throughout the whole bar for the case where there is no surface traction on $x_3 = \pm b$. Thus, for a slender bar (thin in both x_2 and x_3 directions) with only equal and opposite compressive forces P acting on its long end faces, there is only one stress component T_{11} inside the bar given by Eq. (5.25.7) and (5.25.13). That is:

$$T_{11} = -\frac{P}{2c} - \frac{2P}{c} \sum_{m=1}^{\infty} \left\{ \frac{(\sinh \lambda_m \ell + \lambda_m \ell \cosh \lambda_m \ell) \cosh \lambda_m x_1 - \lambda_m x_1 \sinh \lambda_m \ell \sinh \lambda_m x_1}{\sinh 2\lambda_m \ell + 2\lambda_m \ell} \right\} \cos \lambda_m x_2. \quad (5.25.16)$$

The first term $P/2c$ is the uniform compressive stress describing the compressive force P divided by the cross-section area (recall that P is per unit length in the x_3 direction); the second term modified this uniform distribution. We see that for $x_1 = 0$ (the midsection of the slender bar), this second term becomes

$$-\frac{2P}{c} \sum_{m=1}^{\infty} \left\{ \frac{(\sinh \lambda_m \ell + \lambda_m \ell \cosh \lambda_m \ell)}{\sinh 2\lambda_m \ell + 2\lambda_m \ell} \right\} \cos \lambda_m x_2. \quad (5.25.17)$$

As $\lambda_m \ell \equiv m\pi(\ell/c) \rightarrow \infty$, $\frac{(\sinh \lambda_m \ell + \lambda_m \ell \cosh \lambda_m \ell)}{\{\sinh 2\lambda_m \ell + 2\lambda_m \ell\}} \rightarrow \frac{\lambda_m \ell}{2 \sinh \lambda_m \ell} \rightarrow 0$, that is, at $x_1 = 0$ (the midsection of the bar), the distribution of T_{11} is uniform for a very slender bar. Numerical calculations will show that for small value of x_1/ℓ (i.e., for sections that are far from the loaded ends), the contribution from the second term will be small and the distribution of T_{11} will be essentially uniform, in agreement with St. Venant's principle.

5.26 CONVERSION FOR STRAINS BETWEEN PLANE STRAIN AND PLANE STRESS SOLUTIONS

In terms of shear modulus and Poisson ratio, the strain components are, for the plane strain solution,

$$E_{11} = \frac{1}{2\mu} \left[(1 - \nu)T_{11} - \nu T_{22} \right], \quad E_{22} = \frac{1}{2\mu} \left[(1 - \nu)T_{22} - \nu T_{11} \right], \quad E_{12} = \frac{T_{12}}{2\mu}, \quad (5.26.1)$$

and for the plane stress solution:

$$E_{11} = \frac{1}{2\mu(1 + \bar{\nu})} [T_{11} - \bar{\nu} T_{22}], \quad E_{22} = \frac{1}{2\mu(1 + \bar{\nu})} [T_{22} - \bar{\nu} T_{11}], \quad E_{12} = \frac{T_{12}}{2\mu}. \quad (5.26.2)$$

In the preceding equations, μ is the shear modulus and *to facilitate the conversion*, we have used ν and $\bar{\nu}$ for the *same* Poisson ratio in the two sets of equations (ν for plane strain and $\bar{\nu}$ for plane stress).

If we let $\nu = \frac{\bar{\nu}}{1 + \bar{\nu}}$, then $1 - \nu = 1 - \frac{\bar{\nu}}{1 + \bar{\nu}} = \frac{1}{1 + \bar{\nu}}$ and Eqs. (5.26.1) are converted to Eqs. (5.26.2). That is, by replacing the Poisson ratio ν in plane strain solution with $\nu/(1 + \nu)$, the strains are converted to those in the plane stress solution.

On the other hand, if we let $\bar{\nu} = \frac{\nu}{1 - \nu}$, then $1 + \bar{\nu} = 1 + \frac{\nu}{1 - \nu} = \frac{1}{1 - \nu}$ and Eqs. (5.26.2) are converted to Eqs. (5.26.1). That is, by replacing the Poisson ratio ν in the plane stress solution with $\nu/(1 - \nu)$, the strains are converted to those in the plane strain solution.

Example 5.26.1

Given that the displacement components in a plane strain solution are given by

$$\begin{aligned} u_r &= \frac{1}{E_Y} \left[-\frac{(1 + \nu)A}{r} - B(1 + \nu)r + 2B(1 - \nu - 2\nu^2)r \ln r + 2C(1 - \nu - 2\nu^2)r \right], \\ u_\theta &= \frac{4Br\theta}{E_Y} (1 - \nu^2). \end{aligned} \quad (i)$$

Find (u_r, u_θ) in the plane stress solution in terms of μ and ν and in terms of E_Y and ν .

Solution

$E_Y = 2\mu(1 + \nu)$; therefore,

$$\begin{aligned} u_r &= \frac{1}{2\mu(1 + \nu)} \left[-\frac{(1 + \nu)A}{r} - B(1 + \nu)r + 2B(1 - \nu - 2\nu^2)r \ln r + 2C(1 - \nu - 2\nu^2)r \right] \\ &= \frac{1}{2\mu} \left[-\frac{A}{r} - Br + 2B(1 - 2\nu)r \ln r + 2C(1 - 2\nu)r \right], \\ u_\theta &= \frac{4Br\theta}{2\mu(1 + \nu)} (1 - \nu^2) = \frac{2Br\theta}{\mu} (1 - \nu). \end{aligned} \quad (ii)$$

Replacing ν with $\frac{\nu}{1 + \nu}$, $1 - 2\nu$ becomes $1 - \frac{2\nu}{1 + \nu} = \frac{1 - \nu}{1 + \nu}$ and $1 - \nu$ becomes $1 - \frac{\nu}{1 + \nu} = \frac{1}{1 + \nu}$; therefore, the components in plane stress solution should be

$$\begin{aligned} u_r &= \frac{1}{2\mu} \left[-\frac{A}{r} - Br + 2B\frac{1 - \nu}{1 + \nu}r \ln r + 2C\frac{1 - \nu}{1 + \nu}r \right] \\ &= \frac{1}{E_Y} \left[-\frac{A(1 + \nu)}{r} - B(1 + \nu)r + 2B(1 - \nu)r \ln r + 2C(1 - \nu)r \right]. \end{aligned} \quad (iii)$$

$$u_\theta = \frac{2Br\theta}{\mu} \frac{1}{(1 + \nu)} = \frac{4Br\theta}{E_Y}. \quad (iv)$$

5.27 TWO-DIMENSIONAL PROBLEMS IN POLAR COORDINATES

The equations of equilibrium in polar coordinates are (see Section 4.8)

$$\frac{1}{r} \frac{\partial(rT_{rr})}{\partial r} + \frac{1}{r} \frac{\partial T_{r\theta}}{\partial \theta} - \frac{T_{\theta\theta}}{r} = 0. \quad (5.27.1)$$

$$\frac{1}{r^2} \frac{\partial(r^2 T_{\theta r})}{\partial r} + \frac{1}{r} \frac{\partial T_{\theta\theta}}{\partial \theta} = 0. \quad (5.27.2)$$

It can be easily verified (see Prob. 5.70) that the preceding equations of equilibrium are identically satisfied if

$$T_{rr} = \frac{1}{r} \frac{\partial \varphi}{\partial r} + \frac{1}{r^2} \frac{\partial^2 \varphi}{\partial \theta^2}, \quad T_{\theta\theta} = \frac{\partial^2 \varphi}{\partial r^2}, \quad T_{r\theta} = -\frac{\partial}{\partial r} \left(\frac{1}{r} \frac{\partial \varphi}{\partial \theta} \right), \quad (5.27.3)$$

where $\varphi(r, \theta)$ is the Airy stress function in polar coordinates. Of course, Eqs. (5.27.3) can be obtained from the Airy stress function defined in Cartesian coordinates via coordinate transformations (see Prob. 5.71).

We have shown in Sections 5.20 and 5.22 that for the in-plane strain components to be compatible, the Airy stress function must satisfy the biharmonic equation

$$\nabla^2 \nabla^2 \varphi = \left(\frac{\partial^2}{\partial x_1^2} + \frac{\partial^2}{\partial x_2^2} \right) \left(\frac{\partial^2 \varphi}{\partial x_1^2} + \frac{\partial^2 \varphi}{\partial x_2^2} \right) = 0. \quad (5.27.4)$$

In polar coordinates,

$$\nabla^2 = \left(\frac{\partial^2}{\partial x_1^2} + \frac{\partial^2}{\partial x_2^2} \right) = \left(\frac{1}{r} \frac{\partial}{\partial r} + \frac{1}{r^2} \frac{\partial^2}{\partial \theta^2} + \frac{\partial^2}{\partial r^2} \right). \quad (5.27.5)$$

Thus, we have the biharmonic equation in polar coordinates:

$$\left(\frac{1}{r} \frac{\partial}{\partial r} + \frac{1}{r^2} \frac{\partial^2}{\partial \theta^2} + \frac{\partial^2}{\partial r^2} \right) \left(\frac{1}{r} \frac{\partial \varphi}{\partial r} + \frac{1}{r^2} \frac{\partial^2 \varphi}{\partial \theta^2} + \frac{\partial^2 \varphi}{\partial r^2} \right) = 0. \quad (5.27.6)$$

The in-plane strain components are as follows:

(A) For the plane strain solution,

$$\begin{aligned} E_{rr} &= \frac{1}{E_Y} [(1 - \nu^2)T_{rr} - \nu(1 + \nu)T_{\theta\theta}], & E_{\theta\theta} &= \frac{1}{E_Y} [(1 - \nu^2)T_{\theta\theta} - \nu(1 + \nu)T_{rr}], \\ E_{r\theta} &= \frac{(1 + \nu)}{E_Y} T_{r\theta}. \end{aligned} \quad (5.27.7)$$

(B) For the plane stress solution,

$$E_{rr} = \frac{1}{E_Y} [T_{rr} - \nu T_{\theta\theta}], \quad E_{\theta\theta} = \frac{1}{E_Y} [T_{\theta\theta} - \nu T_{rr}], \quad E_{r\theta} = \frac{(1 + \nu)}{E_Y} T_{r\theta}. \quad (5.27.8)$$

5.28 STRESS DISTRIBUTION SYMMETRICAL ABOUT AN AXIS

Let the axis of symmetry be the z -axis. We consider the case where the stress components are symmetrical about the z -axis so that they depend only on r and $T_{r\theta} = 0$. That is,

$$T_{rr} = T_{rr}(r), \quad T_{\theta\theta} = T_{\theta\theta}(r), \quad T_{r\theta} = 0. \quad (5.28.1)$$

In terms of the Airy stress function, we have

$$T_{rr} = \frac{1}{r} \frac{d\varphi}{dr}, \quad T_{\theta\theta} = \frac{d^2\varphi}{dr^2}, \quad T_{r\theta} = 0, \quad (5.28.2)$$

and the biharmonic equation becomes

$$\nabla^4\varphi = \left(\frac{d^2}{dr^2} + \frac{1}{r} \frac{d}{dr} \right) \left(\frac{d^2\varphi}{dr^2} + \frac{1}{r} \frac{d\varphi}{dr} \right) = 0. \quad (5.28.3)$$

The general solution for this ordinary differential equation (the Euler equation) can easily be found to be

$$\varphi = A \ln r + Br^2 \ln r + Cr^2 + D, \quad (5.28.4)$$

from which, we have

$$\begin{aligned} T_{rr} &= \frac{1}{r} \frac{d\varphi}{dr} = \frac{A}{r^2} + B(1 + 2 \ln r) + 2C, \\ T_{\theta\theta} &= \frac{d^2\varphi}{dr^2} = -\frac{A}{r^2} + B(3 + 2 \ln r) + 2C, \\ T_{r\theta} &= 0. \end{aligned} \quad (5.28.5)$$

5.29 DISPLACEMENTS FOR SYMMETRICAL STRESS DISTRIBUTION IN PLANE STRESS SOLUTION

From the strain-displacement relations, we have

$$\begin{aligned} E_{rr} &= \frac{\partial u_r}{\partial r} = \frac{1}{E_Y} (T_{rr} - \nu T_{\theta\theta}) \\ &= \frac{1}{E_Y} \left[\frac{A}{r^2} (1 + \nu) + B(1 - 3\nu) + 2B(1 - \nu) \ln r + 2C(1 - \nu) \right], \end{aligned} \quad (5.29.1)$$

$$\begin{aligned} E_{\theta\theta} &= \frac{1}{r} \frac{\partial u_\theta}{\partial \theta} + \frac{u_r}{r} = \frac{1}{E_Y} (T_{\theta\theta} - \nu T_{rr}) \\ &= \frac{1}{E_Y} \left[-(1 + \nu) \frac{A}{r^2} + (3 - \nu)B + 2B(1 - \nu) \ln r + 2(1 - \nu)C \right], \end{aligned} \quad (5.29.2)$$

$$E_{r\theta} = \frac{1}{2} \left(\frac{1}{r} \frac{\partial u_r}{\partial \theta} + \frac{\partial u_\theta}{\partial r} - \frac{u_\theta}{r} \right) = \frac{T_{r\theta}}{2\mu} = 0. \quad (5.29.3)$$

Integration of Eq. (5.29.1) gives

$$u_r = \frac{1}{E_Y} \left[-\frac{A}{r}(1+\nu) + 2B(1-\nu)r \ln r - (1+\nu)Br + 2C(1-\nu)r \right] + f(\theta). \quad (5.29.4)$$

Equations (5.29.2) and (5.29.4) then give

$$\frac{\partial u_\theta}{\partial \theta} = \frac{4Br}{E_Y} - f(\theta). \quad (5.29.5)$$

Integration of the preceding equation gives

$$u_\theta = \frac{4Br\theta}{E_Y} - \int f(\theta)d\theta + g(r), \quad (5.29.6)$$

where $g(r)$ is the integration function. Using Eqs. (5.29.4), (5.29.6), and (5.29.3), we have

$$\frac{1}{r} \frac{\partial u_r}{\partial \theta} + \frac{\partial u_\theta}{\partial r} - \frac{u_\theta}{r} = \frac{1}{r} \frac{df}{d\theta} + \frac{dg}{dr} + \frac{1}{r} \int f(\theta)d\theta - \frac{g(r)}{r} = 0. \quad (5.29.7)$$

Thus,

$$\frac{df}{d\theta} + \int f(\theta)d\theta = g(r) - r \frac{dg}{dr} = D, \quad (5.29.8)$$

from which we have

$$\frac{d^2f}{d\theta^2} + f(\theta) = 0 \quad \text{and} \quad \frac{d^2g}{dr^2} = 0. \quad (5.29.9)$$

The solution of the first equation in Eq. (5.29.9) is

$$f(\theta) = H \sin \theta + G \cos \theta, \quad (5.29.10)$$

from which

$$\int f(\theta)d\theta = -H \cos \theta + G \sin \theta + N, \quad (5.29.11)$$

and

$$df/d\theta + \int f(\theta)d\theta = H \cos \theta - G \sin \theta - H \cos \theta + G \sin \theta + N = N. \quad (5.29.12)$$

Comparing this with Eq. (5.29.8), we get $D=N$. The solution of the second equation in Eq. (5.29.9) is

$$g(r) = Fr + K, \quad (5.29.13)$$

from which we have $g(r) - rdg/dr = K$. Thus, from Eq. (5.29.8), $K = D = N$. That is,

$$g(r) = Fr + N \quad \text{and} \quad \int f(\theta)d\theta = -H \cos \theta + G \sin \theta + N. \quad (5.29.14)$$

Finally, using Eq. (5.29.10) in Eq. (5.29.4) and Eq. (5.29.14) in Eq. (5.29.6), we have

$$u_r = \frac{1}{E_Y} \left[-\frac{A}{r}(1+\nu) + 2B(1-\nu)r \ln r - (1+\nu)Br + 2C(1-\nu)r \right] \quad (5.29.15)$$

$$+ H \sin \theta + G \cos \theta.$$

$$u_\theta = \frac{4Br\theta}{E_Y} + H \cos \theta - G \sin \theta + Fr, \quad (5.29.16)$$

where H , G and F are constants. We note that the terms involving H , G and F represent rigid body displacements as can be easily verified by calculating their $\nabla \mathbf{u}$. Excluding the rigid body displacements, we have

$$u_r = \frac{1}{E_Y} \left[-\frac{A}{r}(1+\nu) + 2B(1-\nu)r \ln r - (1+\nu)Br + 2C(1-\nu)r \right], \quad (5.29.17)$$

$$u_\theta = \frac{4Br\theta}{E_Y}. \quad (5.29.18)$$

5.30 THICK-WALLED CIRCULAR CYLINDER UNDER INTERNAL AND EXTERNAL PRESSURE

Consider a circular cylinder subjected to the action of an internal pressure p_i and an external pressure p_o . The boundary conditions for the two-dimensional problem (plane strain or plane stress) are

$$\begin{aligned} T_{rr} &= -p_i & \text{at } r = a, \\ T_{rr} &= -p_o & \text{at } r = b. \end{aligned} \quad (5.30.1)$$

The stress field will clearly be symmetrical with respect to the z axis; therefore, we expect the stress components to be given by Eq. (5.28.5) and the displacement field to be given by Eqs. (5.29.17) and (5.29.18). Equation (5.29.18) states that $u_\theta = 4Br\theta/E_Y$, which is a multivalued function within the domain of the problem, taking on different values at the same point (e.g., $\theta = 0$ and $\theta = 2\pi$ for the same point). Therefore, the constant B in Eqs. (5.28.5) must be zero. Thus,

$$T_{rr} = \frac{A}{r^2} + 2C, \quad T_{\theta\theta} = -\frac{A}{r^2} + 2C, \quad T_{r\theta} = 0. \quad (5.30.2)$$

Applying the boundary conditions Eqs. (5.30.1), we easily obtain

$$A = \frac{(-p_i + p_o)a^2b^2}{(b^2 - a^2)}, \quad C = \frac{-p_i a^2 + p_o b^2}{2(a^2 - b^2)}, \quad (5.30.3)$$

so that

$$\begin{aligned} T_{rr} &= -p_i \frac{(b^2/r^2) - 1}{(b^2/a^2) - 1} - p_o \frac{1 - (a^2/r^2)}{1 - (a^2/b^2)}, \\ T_{\theta\theta} &= p_i \frac{(b^2/r^2) + 1}{(b^2/a^2) - 1} - p_o \frac{1 + (a^2/r^2)}{1 - (a^2/b^2)}. \end{aligned} \quad (5.30.4)$$

We note that if only the internal pressure p_i is acting, T_{rr} is always a compressive stress and $T_{\theta\theta}$ is always a tensile stress.

For the plane stress solution, the displacement field is given by Eq. (5.29.17) with the constant A and C given by Eqs. (5.30.3) and $B=0$. For the plane strain solution, the displacements are given by Eq. (5.29.17), with the Poisson ratio ν replaced by $\nu/(1-\nu)$ (see Section 5.26).

Example 5.30.1

Consider a thick-walled cylinder subjected to the action of external pressure p_o only. If the outer radius is much, much larger than the inner radius, what is the stress field?

Solution

From Eq. (5.30.4) with $p_i = 0$, we have

$$T_{rr} = -\rho_o \frac{1 - (a^2/r^2)}{1 - (a^2/b^2)}, \quad T_{\theta\theta} = -\rho_o \frac{1 + (a^2/r^2)}{1 - (a^2/b^2)}, \quad T_{r\theta} = 0. \quad (5.30.5)$$

If $a/b \rightarrow 0$, then we have

$$T_{rr} = -\rho_o \left(1 - \frac{a^2}{r^2}\right), \quad T_{\theta\theta} = -\rho_o \left(1 + \frac{a^2}{r^2}\right), \quad T_{r\theta} = 0. \quad (5.30.6)$$

5.31 PURE BENDING OF A CURVED BEAM

Figure 5.31-1 shows a curved beam whose boundary surfaces are given by $r = a$, $r = b$, $\theta \pm \alpha$ and $z = \pm h/2$. The boundary surfaces $r = a$, $r = b$ and $z = \pm h/2$ are traction-free. Assuming the dimension h to be very small compared with the other dimensions, we wish to obtain a plane stress solution for this curved beam under the action of equal and opposite bending couples on the faces $\theta = \pm \alpha$.

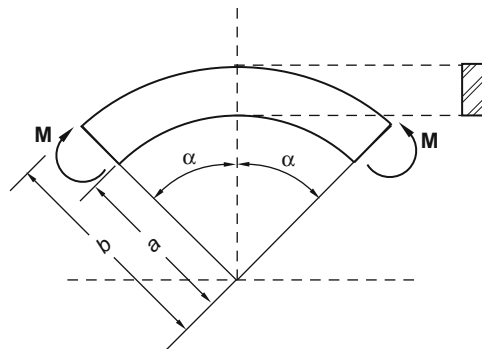

FIGURE 5.31-1

The state of stress is expected to be axisymmetric about the z -axis. Thus, from Section 5.28, we have

$$T_{rr} = \frac{A}{r^2} + B(1 + 2 \ln r) + 2C, \quad T_{\theta\theta} = -\frac{A}{r^2} + B(3 + 2 \ln r) + 2C, \quad T_{r\theta} = 0. \quad (5.31.1)$$

Applying the boundary conditions $T_{rr}(a) = T_{rr}(b) = 0$, we have

$$0 = \frac{A}{a^2} + B(1 + 2 \ln a) + 2C, \quad 0 = \frac{A}{b^2} + B(1 + 2 \ln b) + 2C. \quad (5.31.2)$$

On the face $\theta = \alpha$, there is a distribution of normal stress $T_{\theta\theta}$ given in Eqs. (5.31.1). The resultant of this distribution of stress is given by

$$R = \int_a^b T_{\theta\theta} h dr = h \left[\frac{A}{r} + B(r + 2r \ln r) + 2Cr \right]_a^b = h \left[r \left(\frac{A}{r^2} + B(1 + 2 \ln r) + 2C \right) \right]_a^b. \quad (5.31.3)$$

In view of Eq. (5.31.2), we have

$$R = 0. \quad (5.31.4)$$

Thus, the resultant of the distribution of the normal stress can at most be a couple. Let the moment of this couple per unit width be M , as shown in Figure 5.31-1; then

$$-M = \int_a^b T_{\theta\theta} r dr = - \int_a^b \frac{A}{r} dr + B \int_a^b [2r + (r + 2r \ln r)] dr + 2C \int_a^b r dr. \quad (5.31.5)$$

Integrating, we have [Note: $d(r^2 \ln r) = 2r \ln r + r$]

$$M = A \ln(b/a) - B(b^2 - a^2) - B(b^2 \ln b - a^2 \ln a) - C(b^2 - a^2). \quad (5.31.6)$$

From Eqs. (5.31.2), we can obtain

$$B(b^2 - a^2) = -2B(b^2 \ln b - a^2 \ln a) - 2C(b^2 - a^2). \quad (5.31.7)$$

Thus, Eq. (5.31.6) can be written

$$M = A \ln \frac{b}{a} + B(b^2 \ln b - a^2 \ln a) + C(b^2 - a^2). \quad (5.31.8)$$

Solving Eqs. (5.31.2) and (5.31.8) for A , B and C , we obtain

$$A = -\frac{4M}{N} a^2 b^2 \ln \frac{b}{a}, \quad B = -\frac{2M}{N} (b^2 - a^2), \quad C = \frac{M}{N} [b^2 - a^2 + 2(b^2 \ln b - a^2 \ln a)], \quad (5.31.9)$$

where

$$N = (b^2 - a^2)^2 - 4a^2 b^2 [\ln(b/a)]^2. \quad (5.31.10)$$

Finally,

$$\begin{aligned} T_{rr} &= -\frac{4M}{N} \left(\frac{a^2 b^2}{r^2} \ln \frac{b}{a} + b^2 \ln \frac{r}{b} + a^2 \ln \frac{a}{r} \right), \\ T_{\theta\theta} &= -\frac{4M}{N} \left(\frac{-a^2 b^2}{r^2} \ln \frac{b}{a} + b^2 \ln \frac{r}{b} + a^2 \ln \frac{a}{r} + b^2 - a^2 \right), \\ T_{r\theta} &= 0. \end{aligned} \quad (5.31.11)$$

5.32 INITIAL STRESS IN A WELDED RING

A ring (inner radius a and outer radius b), initially stress free, is cut and a very small wedge of material was removed. A bending moment is then applied to the ring to bring the two cut sections together and welded. The stress generated in the ring can be obtained as follows: Let $\theta=0$ and $\theta=2\pi-\alpha$ be the two cut sections, where α is a very small angle. Without loss of generality, we can assume that the section at $\theta=0$ is fixed. When the two sections are brought together, the displacement u_θ of the particles in the section at $\theta=2\pi-\alpha$ is given by $u_\theta=r\alpha$, where r is the radial distance from the center of the ring. Using Eq. (5.29.18), we obtain

$$(u_\theta)_{\theta=2\pi-\alpha} \approx \frac{4Br(2\pi)}{E_Y} = r\alpha. \quad (5.32.1)$$

Thus,

$$B = \frac{\alpha E_Y}{8\pi}. \quad (5.32.2)$$

The bending moment at every section can be obtained from the second equation in Eq. (5.31.9), i.e., $B = -\frac{2M}{N}(b^2 - a^2)$. Thus,

$$M = -\frac{N\alpha E_Y}{16(b^2 - a^2)\pi}, \quad (5.32.3)$$

where N is given by Eq. (5.31.10). With M so obtained, the stresses are given by Eqs. (5.31.11). We remark that at each section of the welded ring, due to axisymmetry, the shear force must be zero and as a consequence, the axial force is also zero so that the ring is in the state of pure bending.

5.33 AIRY STRESS FUNCTION $\varphi = f(r) \cos n\theta$ AND $\varphi = f(r) \sin n\theta$

Substituting the function $\varphi = f(r) \cos n\theta$ (or $\varphi = f(r) \sin n\theta$) into the biharmonic equation, we obtain (see Prob. 5.73)

$$\left(\frac{d^2}{dr^2} + \frac{1}{r} \frac{d}{dr} - \frac{n^2}{r^2}\right) \left(\frac{d^2 f}{dr^2} + \frac{1}{r} \frac{df}{dr} - \frac{n^2}{r^2} f\right) = 0. \quad (5.33.1)$$

For $n \neq 0$ and $n \neq 1$, the preceding ordinary differential equation has four independent solutions for f (see Prob. 5.74):

$$r^{n+2}, \quad r^{-n+2}, \quad r^n, \quad r^{-n}, \quad (5.33.2)$$

so that for each n there are eight independent solutions for φ in the form of: $\varphi = f(r) \cos n\theta$ and $\varphi = f(r) \sin n\theta$

$$\begin{aligned} & r^{n+2} \cos n\theta, \quad r^{-n+2} \cos n\theta, \quad r^n \cos n\theta, \quad r^{-n} \cos n\theta, \\ & r^{n+2} \sin n\theta, \quad r^{-n+2} \sin n\theta, \quad r^n \sin n\theta, \quad r^{-n} \sin n\theta. \end{aligned} \quad (5.33.3)$$

Therefore, we may write, in general

$$\begin{aligned} \varphi = & (C_1 r^{n+2} + C_2 r^{-n+2} + C_3 r^n + C_4 r^{-n}) \cos n\theta \\ & + (\bar{C}_1 r^{n+2} + \bar{C}_2 r^{-n+2} + \bar{C}_3 r^n + \bar{C}_4 r^{-n}) \sin n\theta. \end{aligned} \quad (5.33.4)$$

However, for $n = 0$, the preceding equation reduces to $C_1 r^2 + C_3 r^0$. Additional independent solutions can be obtained from $\left(\frac{d\varphi}{dn}\right)_{n \rightarrow 0}$. For example,

$$\left[\frac{d}{dn}(r^{n+2} \cos n\theta)\right]_{n=0} = [(r^{n+2} \ln r) \cos n\theta - r^{n+2} \theta \sin n\theta]_{n=0} = r^2 \ln r, \quad (5.33.5)$$

and

$$\left[\frac{d}{dn}(r^{n+2} \sin n\theta)\right]_{n=0} = [(r^{n+2} \ln r) \sin n\theta + r^{n+2} \theta \cos n\theta]_{n=0} = r^2 \theta. \quad (5.33.6)$$

Similarly,

$$\left[\frac{d}{dn}(r^n \cos n\theta)\right]_{n=0} = \ln r, \quad (5.33.7)$$

$$\left[\frac{d}{dn}(r^n \sin n\theta)\right]_{n=0} = \theta. \quad (5.33.8)$$

Thus, we can write, in general, for $n = 0$ (omitting the constant term which does not lead to any stresses),

$$\varphi = A_1 r^2 + A_2 r^2 \ln r + A_3 \ln r + A_4 \theta + A_5 r^2 \theta. \quad (5.33.9)$$

For $n = 1$, $r^{-n+2} = r^n = r$ and the list in Eq. (5.33.3) reduce

$$r^3 \cos \theta, \quad r \cos \theta, \quad r^{-1} \cos \theta, \quad r^3 \sin \theta, \quad r \sin \theta, \quad r^{-1} \sin \theta. \quad (5.33.10)$$

Again, additional independent solutions can be obtained from $\left(\frac{d\varphi}{dn}\right)_{n \rightarrow 1}$:

$$\left[\frac{d}{dn}(r^{-n+2} \cos n\theta)\right]_{n=1} = -r \ln r \cos \theta - r\theta \sin \theta, \quad (5.33.11)$$

$$\left[\frac{d}{dn}(r^n \cos n\theta)\right]_{n=1} = r \ln r \cos \theta - r\theta \sin \theta.$$

$$\left[\frac{d}{dn}(r^{-n+2} \sin n\theta)\right]_{n=1} = -r \ln r \sin \theta + r\theta \cos n\theta, \quad (5.33.12)$$

$$\left[\frac{d}{dn}(r^n \sin n\theta)\right]_{n=1} = r \ln r \sin \theta + r\theta \cos \theta.$$

Thus, we have four additional independent solutions for φ . That is,

$$r \ln r \cos \theta, \quad r\theta \sin \theta, \quad r \ln r \sin \theta, \quad r\theta \cos \theta. \quad (5.33.13)$$

Therefore, for $n = 1$, we can write, in general,

$$\begin{aligned} \varphi = & (B_1 r^3 + B_2 r \ln r + B_3 r + B_4 r^{-1}) \cos \theta + B_5 r \theta \sin \theta \\ & + (\bar{B}_1 r^3 + \bar{B}_2 r \ln r + \bar{B}_3 r + \bar{B}_4 r^{-1}) \sin \theta - \bar{B}_5 r \theta \cos \theta. \end{aligned} \quad (5.33.14)$$

The stresses are for $\varphi = A_1 r^2 + A_2 r^2 \ln r + A_3 \ln r + A_4 \theta + A_5 r^2 \theta$,

$$\begin{aligned} T_{\theta\theta} &= \frac{\partial^2 \varphi}{\partial r^2} = 2A_1 + A_2(2 \ln r + 3) - A_3 r^{-2} + 2A_5 \theta, \\ T_{r\theta} &= -\frac{\partial}{\partial r} \left(\frac{1}{r} \frac{\partial \varphi}{\partial \theta} \right) = A_4 r^{-2} - A_5, \\ T_{rr} &= \frac{1}{r} \frac{\partial \varphi}{\partial r} + \frac{1}{r^2} \frac{\partial^2 \varphi}{\partial \theta^2} = (2A_1 + A_2) + 2A_2 \ln r + A_3 r^{-2} + 2A_5 \theta. \end{aligned} \quad (5.33.15)$$

For $\varphi = (B_1 r^3 + B_2 r \ln r + B_3 r + B_4 r^{-1}) \cos \theta + B_5 r \theta \sin \theta$,

$$\begin{aligned} T_{rr} &= \frac{1}{r^2} \frac{\partial^2 \varphi}{\partial \theta^2} + \frac{1}{r} \frac{\partial \varphi}{\partial r} = \left(2B_1 r + \frac{B_2}{r} - 2\frac{B_4}{r^3} \right) \cos \theta + \frac{2}{r} B_5 \cos \theta, \\ T_{\theta\theta} &= \frac{\partial^2 \varphi}{\partial r^2} = \left(6B_1 r + \frac{B_2}{r} + 2\frac{B_4}{r^3} \right) \cos \theta, \\ T_{r\theta} &= -\frac{\partial}{\partial r} \left(\frac{1}{r} \frac{\partial \varphi}{\partial \theta} \right) = \left(2B_1 r + \frac{B_2}{r} - 2\frac{B_4}{r^3} \right) \sin \theta. \end{aligned} \quad (5.33.16)$$

For $\varphi = (\bar{B}_1 r^3 + \bar{B}_2 r \ln r + \bar{B}_3 r + \bar{B}_4 r^{-1}) \sin \theta - \bar{B}_5 r \theta \cos \theta$,

$$\begin{aligned} T_{rr} &= \frac{1}{r} \frac{\partial \varphi}{\partial r} + \frac{1}{r^2} \frac{\partial^2 \varphi}{\partial \theta^2} = \left(2\bar{B}_1 r + \frac{\bar{B}_2}{r} - 2\bar{B}_4 r^{-3} \right) \sin \theta + \frac{2}{r} \bar{B}_5 \sin \theta, \\ T_{\theta\theta} &= \frac{\partial^2 \varphi}{\partial r^2} = \left(6\bar{B}_1 r + \bar{B}_2 \frac{1}{r} + 2\bar{B}_4 r^{-3} \right) \sin \theta, \\ T_{r\theta} &= -\frac{\partial}{\partial r} \left(\frac{1}{r} \frac{\partial \varphi}{\partial \theta} \right) = -\left(2\bar{B}_1 r + \bar{B}_2 \frac{1}{r} - 2\bar{B}_4 r^{-3} \right) \cos \theta. \end{aligned} \quad (5.33.17)$$

For $\varphi = (C_1 r^{n+2} + C_2 r^{-n+2} + C_3 r^n + C_4 r^{-n}) \cos n\theta$, $n \geq 2$,

$$\begin{aligned} T_{rr} &= \frac{1}{r^2} \frac{\partial^2 \varphi}{\partial \theta^2} + \frac{1}{r} \frac{\partial \varphi}{\partial r} = \left[C_1 r^n \{(n+2) - n^2\} + C_2 r^{-n} \{(-n+2) - n^2\} \right. \\ &\quad \left. + C_3 r^{n-2} \{n - n^2\} - C_4 r^{-n-2} \{n + n^2\} \right] \cos n\theta, \\ T_{\theta\theta} &= \frac{\partial^2 \varphi}{\partial r^2} = \left[C_1 (n+2)(n+1)r^n + (-n+2)(-n+1)C_2 r^{-n} \right. \\ &\quad \left. + C_3 n(n-1)r^{n-2} - C_4 n(-n-1)r^{-n-2} \right] \cos n\theta, \\ T_{r\theta} &= -\frac{\partial}{\partial r} \left(\frac{1}{r} \frac{\partial \varphi}{\partial \theta} \right) = n \left[C_1 (n+1)r^n + C_2 (-n+1)r^{-n} + C_3 (n-1)r^{n-2} \right. \\ &\quad \left. + C_4 (-n-1)r^{-n-2} \right] \sin n\theta. \end{aligned} \quad (5.33.18)$$

For $\varphi = (\bar{C}_1 r^{n+2} + \bar{C}_2 r^{-n+2} + \bar{C}_3 r^n + \bar{C}_4 r^{-n}) \sin n\theta$, $n \geq 2$, replace C_i with \bar{C}_i , $\cos n\theta$ with $\sin n\theta$, and $\sin n\theta$ with $-\cos n\theta$ in the preceding equations.

Example 5.33.1

Given the boundary conditions for a circular cylinder with an inner radius a and an outer radius b as follows:

$$T_{rr} = \frac{\sigma}{2} \cos 2\theta, \quad T_{r\theta} = -\frac{\sigma}{2} \sin 2\theta, \quad \text{at } r = b, \quad (5.33.19)$$

$$T_{rr} = 0, \quad T_{r\theta} = 0, \quad \text{at } r = a. \quad (5.33.20)$$

Find the in-plane stress field for (i) any a and b and (ii) the case where $b/a \rightarrow \infty$.

Solution

Consider $\varphi = f(r) \cos 2\theta$. From Eq. (5.33.18). With $n = 2$, we have

$$T_{\theta\theta} = \frac{\partial^2 \varphi}{\partial r^2} = (12C_1 r^2 + 2C_3 + 6C_4 r^{-4}) \cos 2\theta,$$

$$T_{r\theta} = -\frac{\partial}{\partial r} \left(\frac{1}{r} \frac{\partial \varphi}{\partial \theta} \right) = (6C_1 r^2 - 2C_2 r^{-2} + 2C_3 - 6C_4 r^{-4}) \sin 2\theta, \quad (5.33.21)$$

$$T_{rr} = \frac{1}{r^2} \frac{\partial^2 \varphi}{\partial \theta^2} + \frac{1}{r} \frac{\partial \varphi}{\partial r} = -(4C_2 r^{-2} + 2C_3 + 6C_4 r^{-4}) \cos 2\theta.$$

Applying boundary conditions Eq. (5.33.19) and (5.33.20), we have

$$\begin{aligned} 4C_2 b^{-2} + 2C_3 + 6C_4 b^{-4} &= -\sigma/2, \\ 6C_1 b^2 - 2C_2 b^{-2} + 2C_3 - 6C_4 b^{-4} &= -\sigma/2, \\ 2C_2 a^{-2} + C_3 + 3C_4 a^{-4} &= 0, \\ 3C_1 a^2 - C_2 a^{-2} + C_3 - 3C_4 a^{-4} &= 0. \end{aligned}$$

(i) The solutions for the constants from the preceding four equations are

$$\begin{aligned} C_1 &= \left(\frac{\sigma}{12} \right) \frac{(36b^{-2}a^2 - 36b^{-4}a^4)b^{-2}}{N}, \quad C_2 = \left(\frac{\sigma}{4} \right) \frac{(-12b^{-6}a^6 + 12)a^2}{N}, \\ C_3 &= -\left(\frac{\sigma}{2} \right) \frac{(9a^4b^{-4} - 12b^{-6}a^6 + 3)}{N}, \quad C_4 = -\left(\frac{\sigma}{2} \right) \frac{(-3a^4b^{-4} + 3)a^4}{N}, \end{aligned} \quad (5.33.22)$$

where

$$N = (-24b^{-6}a^6 - 24b^{-2}a^2 + 6b^{-8}a^8 + 36b^{-4}a^4 + 6). \quad (5.33.23)$$

(ii) As $b/a \rightarrow \infty$,

$$C_1 \rightarrow 0, \quad C_2 \rightarrow \left(\frac{\sigma}{2} \right) a^2, \quad C_3 \rightarrow -\left(\frac{\sigma}{4} \right), \quad C_4 \rightarrow -\left(\frac{\sigma}{4} \right) a^4, \quad (5.33.24)$$

$$T_{rr} = \left(\frac{\sigma}{2} \right) \left(1 - \frac{4a^2}{r^2} + \frac{3a^4}{r^4} \right) \cos 2\theta, \quad T_{\theta\theta} = -\left(\frac{\sigma}{2} \right) \left(1 + \frac{3a^4}{r^4} \right) \cos 2\theta, \quad (5.33.25)$$

$$T_{r\theta} = -\left(\frac{\sigma}{2} \right) \left(1 - \frac{3a^4}{r^4} + \frac{2a^2}{r^2} \right) \sin 2\theta.$$

Example 5.33.2

For $\varphi = (\bar{C}_1 r^{n+2} + \bar{C}_2 r^{-n+2} + \bar{C}_3 r^n + \bar{C}_4 r^{-n}) \sin n\theta$, find the stresses for $n = 2$.

Solution

$$T_{\theta\theta} = \frac{\partial^2 \varphi}{\partial r^2} = [12\bar{C}_1 r^2 + 2\bar{C}_3 + 6\bar{C}_4 r^{-4}] \sin 2\theta,$$

$$T_{r\theta} = -\frac{\partial}{\partial r} \left(\frac{1}{r} \frac{\partial \varphi}{\partial \theta} \right) = -[6\bar{C}_1 r^2 - 2\bar{C}_2 r^{-2} - 2\bar{C}_3 - 6\bar{C}_4 r^{-4}] \cos 2\theta,$$

$$T_{rr} = \frac{1}{r^2} \frac{\partial^2 \varphi}{\partial \theta^2} + \frac{1}{r} \frac{\partial \varphi}{\partial r} = [-4\bar{C}_2 r^{-2} - 2\bar{C}_3 - 6\bar{C}_4 r^{-4}] \sin n\theta.$$

The preceding equations are obtained from Eq. (5.33.18) by replacing C_i with \bar{C}_i , $\cos n\theta$ with $\sin n\theta$, and $\sin n\theta$ with $-\cos n\theta$ in the equations.

5.34 STRESS CONCENTRATION DUE TO A SMALL CIRCULAR HOLE IN A PLATE UNDER TENSION

Figure 5.34-1 shows a plate with a small circular hole of radius a subjected to the actions of uniform tensile stress σ on the edge faces perpendicular to the x_1 direction. Let us consider the region between two concentric circles: $r = a$ and $r = b$. The surface $r = a$ is traction free, i.e.,

$$T_{rr} = 0 \quad \text{and} \quad T_{r\theta} = 0 \quad \text{at} \quad r = a. \quad (5.34.1)$$

If b is much larger than a , then the effect of the small hole will be negligible on points lying on the surface $r = b$ so that the state of stress at $r = b$ for $a/b \rightarrow 0$ will be that due to the uniaxial tensile stress σ in the absence of the hole. In Cartesian coordinates, the state of stress is simply $T_{11} = \sigma$ with all other $\sigma_{ij} = 0$. In polar coordinates, this same state of stress has the following nonzero stress components:

$$T_{rr} = \frac{\sigma}{2} + \frac{\sigma}{2} \cos 2\theta, \quad T_{\theta\theta} = \frac{\sigma}{2} - \frac{\sigma}{2} \cos 2\theta, \quad T_{r\theta} = -\frac{\sigma}{2} \sin 2\theta. \quad (5.34.2)$$

Equations (5.34.2) can be obtained from the equation $[\mathbf{T}]_{\{\mathbf{e}_r, \mathbf{e}_\theta\}} = [\mathbf{Q}]^T [\mathbf{T}]_{\{\mathbf{e}_1, \mathbf{e}_2\}} [\mathbf{Q}]$ where the tensor \mathbf{Q} rotates $\{\mathbf{e}_1, \mathbf{e}_2\}$ into $\{\mathbf{e}_r, \mathbf{e}_\theta\}$ and by using the identities $\cos^2 \theta = (1 + \cos 2\theta)/2$, $\sin^2 \theta = (1 - \cos 2\theta)/2$, and $\sin 2\theta = 2 \sin \theta \cos \theta$. Thus, we have

$$T_{rr} = \frac{\sigma}{2} + \frac{\sigma}{2} \cos 2\theta, \quad T_{r\theta} = -\frac{\sigma}{2} \sin 2\theta, \quad \text{at} \quad r = b. \quad (5.34.3)$$

The solution we are looking for must satisfy both the boundary conditions given in Eqs. (5.34.1) and (5.34.3). We shall obtain the solution by superposing the following two solutions:

1. The solution that satisfies the following boundary conditions:

$$T_{rr} = 0, \quad T_{r\theta} = 0 \quad \text{at} \quad r = a \quad \text{and} \quad T_{rr} = \frac{\sigma}{2}, \quad T_{r\theta} = 0 \quad \text{at} \quad r = b, \quad \text{and} \quad (5.34.4)$$

2. The solution that satisfies the following boundary conditions:

$$T_{rr} = 0, \quad T_{r\theta} = 0 \quad \text{at} \quad r = a \quad \text{and} \quad T_{rr} = \frac{\sigma}{2} \cos 2\theta, \quad T_{r\theta} = -\frac{\sigma}{2} \sin 2\theta \quad \text{at} \quad r = b. \quad (5.34.5)$$

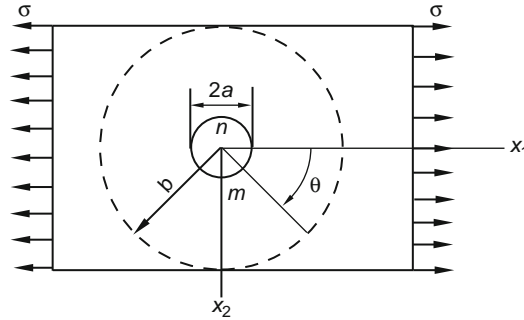

FIGURE 5.34-1

The solution that satisfies Eq. (5.34.4) is given by Eq. (5.30.6) for the thick-walled cylinder with $p_o = -\sigma/2$ and $a/b \rightarrow 0$:

$$T_{rr} = \frac{\sigma}{2} \left(1 - \frac{a^2}{r^2} \right), \quad T_{\theta\theta} = \frac{\sigma}{2} \left(1 + \frac{a^2}{r^2} \right), \quad T_{r\theta} = 0. \quad (5.34.6)$$

The solution that satisfies Eq. (5.34.5) is given by Eq. (5.33.25) in Example 5.33.1:

$$\begin{aligned} T_{rr} &= \left(\frac{\sigma}{2} \right) \left(1 - \frac{4a^2}{r^2} + \frac{3a^4}{r^4} \right) \cos 2\theta, & T_{\theta\theta} &= - \left(\frac{\sigma}{2} \right) \left(1 + \frac{3a^4}{r^4} \right) \cos 2\theta, \\ T_{r\theta} &= - \left(\frac{\sigma}{2} \right) \left(1 - \frac{3a^4}{r^4} + \frac{2a^2}{r^2} \right) \sin 2\theta. \end{aligned} \quad (5.34.7)$$

Combining Eqs. (5.34.6) and (5.34.7), we obtain

$$\begin{aligned} T_{rr} &= \frac{\sigma}{2} \left(1 - \frac{a^2}{r^2} \right) + \frac{\sigma}{2} \left(1 + \frac{3a^4}{r^4} - \frac{4a^2}{r^2} \right) \cos 2\theta, \\ T_{r\theta} &= - \frac{\sigma}{2} \left(1 - \frac{3a^4}{r^4} + \frac{2a^2}{r^2} \right) \sin 2\theta, \\ T_{\theta\theta} &= \frac{\sigma}{2} \left(1 + \frac{a^2}{r^2} \right) - \frac{\sigma}{2} \left(1 + \frac{3a^4}{r^4} \right) \cos 2\theta. \end{aligned} \quad (5.34.8)$$

Putting $r = a$ in the preceding equations, we obtain the stresses on the inner circle:

$$T_{rr} = 0, \quad T_{r\theta} = 0, \quad T_{\theta\theta} = \sigma - 2\sigma \cos 2\theta. \quad (5.34.9)$$

We see, therefore, at $\theta = \pi/2$ (point m in Figure 5.34-1) and at $\theta = 3\pi/2$ (point n in the same figure), $T_{\theta\theta} = 3\sigma$. This tensile stress is three times the uniform stress σ in the absence of the hole. This is referred to as the *stress concentration* due to the presence of the small hole.

5.35 STRESS CONCENTRATION DUE TO A SMALL CIRCULAR HOLE IN A PLATE UNDER PURE SHEAR

Figure 5.35-1 shows a plate with a small circular hole of radius a subjected to the actions of pure shear τ . Let us consider the region between two concentric circles: $r = a$ and $r = b$. The surface $r = a$ is traction free, i.e.,

$$T_{rr} = T_{r\theta} = 0 \quad \text{at } r = a. \quad (5.35.1)$$

If b is much larger than a , then the effect of the small hole will be negligible on points lying on the surface $r = b$ so that the state of stress at $r = b$ for $a/b \rightarrow 0$ will be that due to the pure shear τ in the absence of the hole. In Cartesian coordinates, the state of stress is simply given by $T_{12} = T_{21} = \tau$, with all other $T_{ij} = 0$. Using the equation $[\mathbf{T}]_{\{\mathbf{e}_r, \mathbf{e}_\theta\}} = [\mathbf{Q}]^T [\mathbf{T}]_{\{\mathbf{e}_1, \mathbf{e}_2\}} [\mathbf{Q}]$ where the tensor \mathbf{Q} rotates $\{\mathbf{e}_1, \mathbf{e}_2\}$ into $\{\mathbf{e}_r, \mathbf{e}_\theta\}$, we can obtain, for this same state of stress, the components in polar coordinates. They are

$$T_{rr} = \tau \sin 2\theta, \quad T_{\theta\theta} = -\tau \sin 2\theta, \quad T_{r\theta} = \tau \cos 2\theta. \quad (5.35.2)$$

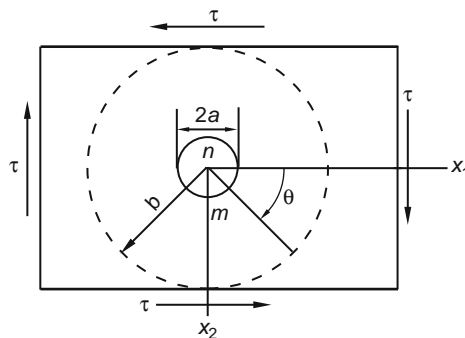

FIGURE 5.35-1

Thus, the boundary conditions for our problem are

$$\begin{aligned} T_{rr} = 0 \quad \text{and} \quad T_{r\theta} = 0 \quad \text{at } r = a, \\ T_{rr} = \tau \sin 2\theta, \quad T_{r\theta} = \tau \cos 2\theta \quad \text{at } r = b \rightarrow \infty. \end{aligned} \quad (5.35.3)$$

In view of the form of the boundary condition at $r = b \rightarrow \infty$, we look for possible states of stress in the form of $f(r) \sin 2\theta$ and $f(r) \cos 2\theta$. In Example 5.33.2, we used the Airy stress function,

$$\varphi = (\bar{C}_1 r^4 + \bar{C}_2 + \bar{C}_3 r^2 + \bar{C}_4 r^{-2}) \sin 2\theta, \quad (5.35.4)$$

to generate the following stress components:

$$\begin{aligned} T_{\theta\theta} &= \frac{\partial^2 \varphi}{\partial r^2} = \left[12\bar{C}_1 r^2 + 2\bar{C}_3 + \frac{6\bar{C}_4}{r^4} \right] \sin 2\theta, \\ T_{r\theta} &= -\frac{\partial}{\partial r} \left(\frac{1}{r} \frac{\partial \varphi}{\partial \theta} \right) = - \left[6\bar{C}_1 r^2 - 2\frac{\bar{C}_2}{r^2} + 2\bar{C}_3 - \frac{6\bar{C}_4}{r^4} \right] \cos 2\theta, \\ T_{rr} &= \frac{1}{r^2} \frac{\partial^2 \varphi}{\partial \theta^2} + \frac{1}{r} \frac{\partial \varphi}{\partial r} = \left[-\frac{4\bar{C}_2}{r^2} - 2\bar{C}_3 - \frac{6\bar{C}_4}{r^4} \right] \sin 2\theta. \end{aligned} \quad (5.35.5)$$

To satisfy the boundary conditions at $r = b \rightarrow \infty$ [see Eqs. (5.35.3)], we must have

$$\bar{C}_1 = 0 \quad \text{and} \quad 2\bar{C}_3 = -\tau. \quad (5.35.6)$$

Thus,

$$\begin{aligned} T_{\theta\theta} &= \left(\tau + \frac{6\bar{C}_4}{r^4} \right) \sin 2\theta, \\ T_{r\theta} &= \left(\frac{2\bar{C}_2}{r^2} + \tau + \frac{6\bar{C}_4}{r^4} \right) \cos 2\theta, \\ T_{rr} &= \left(-\frac{4\bar{C}_2}{r^2} + \tau - \frac{6\bar{C}_4}{r^4} \right) \sin 2\theta. \end{aligned} \quad (5.35.7)$$

The boundary conditions at $r = a$ require that

$$\frac{2\bar{C}_2}{a^2} + \tau + \frac{6\bar{C}_4}{a^4} = 0, \quad -\frac{4\bar{C}_2}{a^2} + \tau - \frac{6\bar{C}_4}{a^4} = 0, \quad (5.35.8)$$

from which we have

$$\bar{C}_2 = a^2\tau, \quad \bar{C}_4 = -\frac{a^4\tau}{2}. \quad (5.35.9)$$

Finally,

$$\begin{aligned} T_{\theta\theta} &= \tau \left(1 - \frac{3a^4}{r^4} \right) \sin 2\theta, \\ T_{r\theta} &= \tau \left(1 + \frac{2a^2}{r^2} - \frac{3a^4}{r^4} \right) \cos 2\theta, \\ T_{rr} &= \tau \left(1 - \frac{4a^2}{r^2} + \frac{3a^4}{r^4} \right) \sin 2\theta. \end{aligned} \quad (5.35.10)$$

5.36 SIMPLE RADIAL DISTRIBUTION OF STRESSES IN A WEDGE LOADED AT THE APEX

Consider a wedge (Figure 5.36-1), defined by $\theta = \pm\alpha$, $0 \leq r \leq \infty$, where the two faces of the wedge $\theta = \pm\alpha$ are traction free except at the apex $r = 0$, where there is a concentrated load $\mathbf{F} = P\mathbf{e}_1$, where \mathbf{e}_1 is pointing to the right. Then the boundary conditions for the problem are

$$T_{\theta\theta} = T_{r\theta} = 0 \quad \text{at} \quad \theta = \pm\alpha, r \neq 0, \quad (5.36.1)$$

and

$$\int_{-\alpha}^{\alpha} (T_{rr} \cos \theta - T_{r\theta} \sin \theta) r d\theta = -P, \quad \int_{-\alpha}^{\alpha} (T_{rr} \sin \theta + T_{r\theta} \cos \theta) r d\theta = 0. \quad (5.36.2)$$

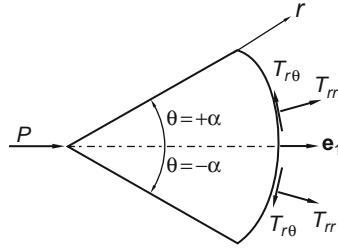

FIGURE 5.36-1

Consider the following Airy stress function [see Eqs. (5.33.16) and (5.33.17) in Section 5.33]:

$$\varphi = B_5 r \theta \sin \theta + \bar{B}_5 r \theta \cos \theta. \quad (5.36.3)$$

The stress components are

$$\begin{aligned} T_{rr} &= \frac{1}{r} \frac{\partial \varphi}{\partial r} + \frac{1}{r^2} \frac{\partial^2 \varphi}{\partial \theta^2} = \frac{1}{r} (2B_5 \cos \theta - 2\bar{B}_5 \sin \theta), \\ T_{\theta\theta} &= \frac{\partial^2 \varphi}{\partial r^2} = 0, \quad T_{r\theta} = -\frac{\partial}{\partial r} \left(\frac{1}{r} \frac{\partial \varphi}{\partial \theta} \right) = 0. \end{aligned} \quad (5.36.4)$$

The stress distribution is purely radial, so the four boundary conditions in Eqs. (5.36.1) are automatically satisfied. The second condition in Eqs. (5.36.2) becomes simply

$$\begin{aligned} \int_{-\alpha}^{\alpha} (T_{rr} \sin \theta) r d\theta &= \int_{-\alpha}^{\alpha} (B_5 \sin 2\theta) d\theta - 2\bar{B}_5 \int_{-\alpha}^{\alpha} (\sin^2 \theta) d\theta \\ &= -2\bar{B}_5 \int_{-\alpha}^{\alpha} (\sin^2 \theta) d\theta = 0. \end{aligned} \quad (5.36.5)$$

Thus, $\bar{B}_5 = 0$. The first condition in Eq. (5.36.2) then gives

$$2B_5 \int_{-\alpha}^{\alpha} \cos^2 \theta d\theta = -P, \quad (5.36.6)$$

from which $B_5 = -P/(2\alpha + \sin 2\alpha)$ and the stress distribution is given by

$$T_{rr} = -\frac{2P}{2\alpha + \sin 2\alpha} \frac{\cos \theta}{r}, \quad T_{\theta\theta} = T_{r\theta} = 0. \quad (5.36.7)$$

5.37 CONCENTRATED LINE LOAD ON A 2-D HALF-SPACE: THE FLAMONT PROBLEM

In the wedge problem of the previous section, if we take α to be $\pi/2$, then we have a two-dimensional half-space, loaded with a concentrated line compressive load P at the origin on the surface, and the stress distribution is given by [see Eqs. (5.36.7)]

$$T_{rr} = -\left(\frac{2P}{\pi}\right) \frac{\cos \theta}{r}, \quad T_{\theta\theta} = T_{r\theta} = 0. \quad (5.37.1)$$

It can be easily verified (see Prob. 5.77) that the displacement field is

$$\begin{aligned} u_r &= -\frac{P}{\pi E_Y} \{(1-\nu)\theta \sin \theta + 2 \ln r \cos \theta\}, \\ u_\theta &= \frac{P}{\pi E_Y} \{(1+\nu) \sin \theta + 2 \ln r \sin \theta - (1-\nu)\theta \cos \theta\}. \end{aligned} \quad (5.37.2)$$

A.4 ELASTOSTATIC PROBLEMS SOLVED WITH POTENTIAL FUNCTIONS

5.38 FUNDAMENTAL POTENTIAL FUNCTIONS FOR ELASTOSTATIC PROBLEMS

Consider the following displacement function for an elastic medium:

$$u_i = \Psi_i - \frac{1}{4(1-\nu)} \frac{\partial}{\partial x_i} (x_n \Psi_n + \Phi), \quad (5.38.1)$$

where $\Psi_i = \Psi_i(x_1, x_2, x_3)$ are components of a vector function, $\Phi = \Phi(x_1, x_2, x_3)$ is a scalar function, and ν is the Poisson's ratio of the elastic medium. Substituting the preceding equation into the Navier equation that follows (where B_i denotes body force per unit volume),

$$\frac{\mu}{1-2\nu} \frac{\partial e}{\partial x_i} + \mu \frac{\partial^2 u_i}{\partial x_j \partial x_j} + B_i = 0, \quad (5.38.2)$$

we obtain (see Prob. 5.79)

$$-\frac{\mu}{2(1-2\nu)} \left(x_n \frac{\partial \nabla^2 \Psi_n}{\partial x_i} - (1-4\nu) \nabla^2 \Psi_i + \frac{\partial \nabla^2 \Phi}{\partial x_i} \right) + B_i = 0. \quad (5.38.3)$$

It can be easily shown (see Example 5.38.1) that Eq. (5.38.3) is identically satisfied by the equations

$$\nabla^2 \Psi_i = -\frac{B_i}{\mu}, \quad \nabla^2 \Phi = \frac{x_i B_i}{\mu}. \quad (5.38.4)$$

In the absence of body forces, Eqs. (5.38.4) become

$$\nabla^2 \Psi_i = 0, \quad \nabla^2 \Phi = 0. \quad (5.38.5)$$

Thus, any functions $\Phi = \Phi(x_1, x_2, x_3)$ and $\Psi_i = \Psi_i(x_1, x_2, x_3)$ that satisfy Eqs. (5.38.4) [or Eqs. (5.38.5)] provide a solution for an elastostatic problem through the displacement field given by Eq. (5.38.1).

In direct notations, Eqs. (5.38.1) and (5.38.4) read, respectively,

$$\mathbf{u} = \Psi - \frac{1}{4(1-\nu)} \nabla(\mathbf{x} \cdot \Psi + \Phi), \quad (5.38.6)$$

and

$$\nabla^2 \Psi = -\frac{\mathbf{B}}{\mu}, \quad \nabla^2 \Phi = \frac{\mathbf{x} \cdot \mathbf{B}}{\mu}. \quad (5.38.7)$$

These functions Φ and Ψ_i in the representation of the displacement field are known as the *fundamental potentials* for elastostatic problems. The advantage of casting the elastostatic problem in terms of these potential functions is that the solutions of Eqs. (5.38.5) [or (5.38.4)] are simpler to obtain than those of

the three displacement functions in Eq. (5.38.2). Special cases of the representation such as $\Psi = 0$ or $\Phi = 0$ have been well known and some of them are included in the examples that follow. We note that the representation given by Eq. (5.38.6) is complete in the sense that all elastostatic problems can be represented by it.

An alternate form of the preceding equation is (see Prob. 5.78):

$$2\mu\mathbf{u} = -4(1-\nu)\boldsymbol{\psi} + \nabla(\mathbf{x} \cdot \boldsymbol{\psi} + \phi), \quad (5.38.8)$$

where

$$\boldsymbol{\psi} = -\frac{\mu}{2(1-\nu)}\boldsymbol{\Psi}, \quad \phi = -\frac{\mu}{2(1-\nu)}\Phi. \quad (5.38.9)$$

In the absence of body forces,

$$\nabla^2\boldsymbol{\psi} = 0, \quad \nabla^2\phi = 0. \quad (5.38.10)$$

Example 5.38.1

Show that Eq. (5.38.3) is identically satisfied by

$$\nabla^2\Psi_i = -B_i/\mu \quad \text{and} \quad \nabla^2\Phi = x_j B_j/\mu.$$

Solution

We have

$$\frac{\partial}{\partial x_i} \nabla^2\Psi_n = \frac{\partial}{\partial x_i} \left(-\frac{B_n}{\mu} \right) = 0 \quad \text{and} \quad \frac{\partial}{\partial x_i} \nabla^2\Phi = \frac{\partial}{\partial x_i} \left(\frac{x_n B_n}{\mu} \right) = \frac{B_n}{\mu} \left(\frac{\partial x_n}{\partial x_i} \right) = \frac{B_i}{\mu}.$$

Therefore,

$$\begin{aligned} -\frac{\mu}{2(1-2\nu)} \left(x_n \frac{\partial \nabla^2\Psi_n}{\partial x_i} - (1-4\nu)\nabla^2\Psi_i + \frac{\partial \nabla^2\Phi}{\partial x_i} \right) + B_i &= -\frac{\mu}{2(1-2\nu)} \left\{ 0 - (1-4\nu) \left(-\frac{B_i}{\mu} \right) + \frac{B_i}{\mu} \right\} \\ + B_i &= -\frac{\mu}{2(1-2\nu)} \{ (1-4\nu) + 1 \} \frac{B_i}{\mu} + B_i = -B_i + B_i = 0. \end{aligned}$$

Thus, $\nabla^2\Psi_i = -B_i/\mu$ and $\nabla^2\Phi = x_j B_j/\mu$ provide a sufficient condition for Eq. (5.38.3) to be satisfied.

In what follows, we use Eq. (5.38.8), i.e.,

$$2\mu\mathbf{u} = -4(1-\nu)\boldsymbol{\psi} + \nabla(\mathbf{x} \cdot \boldsymbol{\psi} + \phi),$$

for the representation and shall always assume that there are no body forces, so that both the vector function $\boldsymbol{\psi}$ and the scalar function ϕ satisfy the Laplace equations.

$$\nabla^2\boldsymbol{\psi} = 0, \quad \nabla^2\phi = 0$$

Example 5.38.2

Consider the following potential functions in Cartesian rectangular coordinates:

$$\boldsymbol{\psi} = 0, \quad \phi = \phi(x_1, x_2, x_3), \quad \text{where} \quad \nabla^2\phi = 0.$$

Obtain the displacements, dilatation, strains, and stresses in terms of ϕ .

Solution

With $2\mu\mathbf{u} = -4(1-\nu)\boldsymbol{\psi} + \nabla(\mathbf{x} \cdot \boldsymbol{\psi} + \phi) = \nabla\phi$,

$$\text{Displacement: } 2\mu u_i = \frac{\partial\phi}{\partial x_i}. \quad (5.38.11)$$

$$\text{Strains: } 2\mu E_{ij} = \mu \left(\frac{\partial u_i}{\partial x_j} + \frac{\partial u_j}{\partial x_i} \right) = \frac{\partial^2\phi}{\partial x_i \partial x_j}. \quad (5.38.12)$$

$$\text{Dilatation: } 2\mu e = 2\mu E_{ii} = \left(\frac{\partial^2\phi}{\partial x_i \partial x_i} \right) = \nabla^2\phi = 0. \quad (5.38.13)$$

$$\text{Stresses: } T_{ij} = 2\mu E_{ij} = \frac{\partial^2\phi}{\partial x_i \partial x_j}. \quad (5.38.14)$$

Example 5.38.3

Consider the following potential functions in cylindrical coordinates:

$$\boldsymbol{\psi} = \psi(r, z)\mathbf{e}_z, \quad \phi = 0, \quad \text{where } \nabla^2\psi = 0. \quad (5.38.15)$$

Show that these functions generate the following displacements, dilatation, and stresses:

(a) Displacement:

$$2\mu u_r = z \frac{\partial\psi}{\partial r}, \quad 2\mu u_z = (-3 + 4\nu)\psi + z \frac{\partial\psi}{\partial z}, \quad u_\theta = 0. \quad (5.38.16)$$

(b) Dilatation:

$$2\mu e = -2(1 - 2\nu) \frac{\partial\psi}{\partial z}. \quad (5.38.17)$$

(c) Stress:

$$T_{rr} = z \frac{\partial^2\psi}{\partial r^2} - 2\nu \frac{\partial\psi}{\partial z}, \quad T_{\theta\theta} = \frac{z}{r} \frac{\partial\psi}{\partial r} - 2\nu \frac{\partial\psi}{\partial z}, \quad T_{zz} = z \frac{\partial^2\psi}{\partial z^2} - 2(1 - \nu) \frac{\partial\psi}{\partial z}, \quad (5.38.18)$$

$$T_{rz} = z \frac{\partial^2\psi}{\partial r \partial z} - (1 - 2\nu) \frac{\partial\psi}{\partial r}, \quad T_{r\theta} = T_{\theta z} = 0. \quad (5.38.19)$$

Solution

(a) With $\mathbf{x} = r\mathbf{e}_r + z\mathbf{e}_z$, $\boldsymbol{\psi} = \psi\mathbf{e}_z$, $\mathbf{x} \cdot \boldsymbol{\psi} = z\psi$,

$$\nabla z\psi = \frac{\partial z\psi}{\partial r}\mathbf{e}_r + \frac{\partial z\psi}{\partial z}\mathbf{e}_z = z \frac{\partial\psi}{\partial r}\mathbf{e}_r + \left[z \frac{\partial\psi}{\partial z} + \psi \right] \mathbf{e}_z.$$

See Eq. (2.34.4).

Thus, Eq. (5.38.8) gives

$$2\mu\mathbf{u} = -4(1 - \nu)\boldsymbol{\psi} + \nabla(\mathbf{x} \cdot \boldsymbol{\psi}) = z \frac{\partial\psi}{\partial r}\mathbf{e}_r + \left[z \frac{\partial\psi}{\partial z} + (-3 + 4\nu)\psi \right] \mathbf{e}_z.$$

(b) The strain components are [see Eq. (3.37.20)]

$$2\mu E_{rr} = 2\mu \frac{\partial u_r}{\partial r} = z \frac{\partial^2 \psi}{\partial r^2}, \quad 2\mu E_{\theta\theta} = 2\mu \frac{u_r}{r} = \frac{z}{r} \frac{\partial \psi}{\partial r}, \quad (5.38.20)$$

$$2\mu E_{zz} = 2\mu \frac{\partial u_z}{\partial z} = \left[(-3 + 4\nu) \frac{\partial \psi}{\partial z} + z \frac{\partial^2 \psi}{\partial z^2} + \frac{\partial \psi}{\partial z} \right] = \left[-2(1 - 2\nu) \frac{\partial \psi}{\partial z} + z \frac{\partial^2 \psi}{\partial z^2} \right], \quad (5.38.21)$$

$$2\mu E_{rz} = \mu \left(\frac{\partial u_z}{\partial r} + \frac{\partial u_r}{\partial z} \right) = -(1 - 2\nu) \frac{\partial \psi}{\partial r} + z \frac{\partial^2 \psi}{\partial r \partial z}, \quad (5.38.22)$$

$$E_{r\theta} = 0 = E_{z\theta}. \quad (5.38.23)$$

The dilatation is given by

$$e = E_{rr} + E_{\theta\theta} + E_{zz} = \frac{1}{2\mu} \left\{ z \frac{\partial^2 \psi}{\partial r^2} + \frac{z}{r} \frac{\partial \psi}{\partial r} - 2(1 - 2\nu) \frac{\partial \psi}{\partial z} + z \frac{\partial^2 \psi}{\partial z^2} \right\}. \quad (5.38.24)$$

A simpler form for e can be obtained if we make use of the fact that ψ satisfies the Laplace equation, i.e.,

$$\frac{\partial^2 \psi}{\partial r^2} + \frac{1}{r} \frac{\partial \psi}{\partial r} + \frac{\partial^2 \psi}{\partial z^2} = 0, \quad (5.38.25)$$

so that

$$e = -\frac{(1 - 2\nu)}{\mu} \frac{\partial \psi}{\partial z}. \quad (5.38.26)$$

(c) To calculate the stress components, we first obtain

$$\frac{2\mu\nu}{1 - 2\nu} e = -2\nu \frac{\partial \psi}{\partial z}.$$

Then, using the strains obtained in (b), we obtain

$$T_{rr} = \frac{2\mu\nu}{1 - 2\nu} e + 2\mu E_{rr} = -2\nu \frac{\partial \psi}{\partial z} + z \frac{\partial^2 \psi}{\partial r^2}, \quad T_{\theta\theta} = \frac{2\mu\nu}{1 - 2\nu} e + 2\mu E_{\theta\theta} = -2\nu \frac{\partial \psi}{\partial z} + \frac{z}{r} \frac{\partial \psi}{\partial r},$$

$$T_{zz} = \frac{2\mu\nu}{1 - 2\nu} e + 2\mu E_{zz} = -2\nu \frac{\partial \psi}{\partial z} + \left[-2(1 - 2\nu) \frac{\partial \psi}{\partial z} + z \frac{\partial^2 \psi}{\partial z^2} \right] = -2(1 - \nu) \frac{\partial \psi}{\partial z} + z \frac{\partial^2 \psi}{\partial z^2},$$

$$T_{rz} = 2\mu E_{rz} = \left[-(1 - 2\nu) \frac{\partial \psi}{\partial r} + z \frac{\partial^2 \psi}{\partial r \partial z} \right], \quad T_{r\theta} = T_{z\theta} = 0.$$

Example 5.38.4

Consider the following potential functions in cylindrical coordinates:

$$\boldsymbol{\psi} = \frac{\partial \varphi}{\partial z} \mathbf{e}_z, \quad \phi = (1 - 2\nu)\varphi, \quad \text{where } \nabla^2 \varphi(r, z) = 0. \quad (5.38.27)$$

Show that these functions generate the following displacements u_i , dilatation e , and stresses T_{ij} :

(a) Displacements:

$$2\mu \mathbf{u} = \left(z \frac{\partial^2 \varphi}{\partial r \partial z} + (1 - 2\nu) \frac{\partial \varphi}{\partial r} \right) \mathbf{e}_r + \left(z \frac{\partial^2 \varphi}{\partial z^2} + (-2 + 2\nu) \frac{\partial \varphi}{\partial z} \right) \mathbf{e}_z. \quad (5.38.28)$$

(b) Dilatation:

$$e = -\frac{(1-2\nu)}{\mu} \frac{\partial^2 \varphi}{\partial z^2}. \quad (5.38.29)$$

(c) Stresses:

$$T_{rr} = -2\nu \frac{\partial^2 \varphi}{\partial z^2} + z \frac{\partial^3 \varphi}{\partial r^2 \partial z} + (1-2\nu) \frac{\partial^2 \varphi}{\partial r^2}, \quad T_{\theta\theta} = z \frac{\partial^2 \varphi}{\partial r \partial z} + 2\nu \left(\frac{\partial^2 \varphi}{\partial r^2} \right) + \frac{1}{r} \frac{\partial \varphi}{\partial r}, \quad (5.38.30)$$

$$T_{zz} = z \frac{\partial^3 \varphi}{\partial z^3} - \frac{\partial^2 \varphi}{\partial z^2}, \quad T_{rz} = z \frac{\partial^3 \varphi}{\partial r \partial z^2}, \quad T_{r\theta} = T_{\theta z} = 0. \quad (5.38.31)$$

Solution

(a) The displacement vector is given by [see Eq. (2.34.4)]

$$\begin{aligned} 2\mu \mathbf{u} &= -4(1-\nu) \boldsymbol{\psi} + \nabla(\mathbf{x} \cdot \boldsymbol{\psi} + \phi) = -4(1-\nu) \frac{\partial \varphi}{\partial z} \mathbf{e}_z + \nabla \left(z \frac{\partial \varphi}{\partial z} + (1-2\nu) \varphi \right) \\ &= -4(1-\nu) \frac{\partial \varphi}{\partial z} \mathbf{e}_z + \left(z \frac{\partial^2 \varphi}{\partial r \partial z} + (1-2\nu) \frac{\partial \varphi}{\partial r} \right) \mathbf{e}_r + \left(z \frac{\partial^2 \varphi}{\partial z^2} + \frac{\partial \varphi}{\partial z} + (1-2\nu) \frac{\partial \varphi}{\partial z} \right) \mathbf{e}_z \\ &= \left(z \frac{\partial^2 \varphi}{\partial r \partial z} + (1-2\nu) \frac{\partial \varphi}{\partial r} \right) \mathbf{e}_r + \left(z \frac{\partial^2 \varphi}{\partial z^2} + (-2+2\nu) \frac{\partial \varphi}{\partial z} \right) \mathbf{e}_z. \end{aligned}$$

(b) From the displacements obtained, the strain components can be obtained as follows [see Eq. (3.7.20)]:

$$2\mu E_{rr} = 2\mu \frac{\partial u_r}{\partial r} = \left(z \frac{\partial^3 \varphi}{\partial r^2 \partial z} + (1-2\nu) \frac{\partial^2 \varphi}{\partial r^2} \right), \quad 2\mu E_{\theta\theta} = 2\mu \frac{u_r}{r} = \left(z \frac{\partial^2 \varphi}{\partial r \partial z} + (1-2\nu) \frac{1}{r} \frac{\partial \varphi}{\partial r} \right),$$

$$2\mu E_{zz} = 2\mu \frac{\partial u_z}{\partial z} = \left(z \frac{\partial^3 \varphi}{\partial z^3} + \frac{\partial^2 \varphi}{\partial z^2} - 2(1-\nu) \frac{\partial^2 \varphi}{\partial z^2} \right) = \left(z \frac{\partial^3 \varphi}{\partial z^3} - (1-2\nu) \frac{\partial^2 \varphi}{\partial z^2} \right),$$

$$2\mu E_{rz} = \mu \left(\frac{\partial u_z}{\partial r} + \frac{\partial u_r}{\partial z} \right)$$

$$= \frac{1}{2} \left(z \frac{\partial^3 \varphi}{\partial r \partial z^2} - 2(1-\nu) \frac{\partial^2 \varphi}{\partial r \partial z} \right) + \frac{1}{2} \left(z \frac{\partial^3 \varphi}{\partial r \partial z^2} + \frac{\partial^2 \varphi}{\partial r \partial z} + (1-2\nu) \frac{\partial^2 \varphi}{\partial z \partial r} \right) = z \frac{\partial^3 \varphi}{\partial r \partial z^2},$$

$$E_{r\theta} = 0 = E_{z\theta}.$$

The dilatation $e = E_{rr} + E_{\theta\theta} + E_{zz}$, thus,

$$2\mu e = \left\{ z \frac{\partial}{\partial z} \left(\frac{\partial^2 \varphi}{\partial r^2} + \frac{1}{r} \frac{\partial^2 \varphi}{\partial r} \right) + z \frac{\partial^3 \varphi}{\partial z^3} + (1-2\nu) \left(\frac{\partial^2 \varphi}{\partial r^2} + \frac{1}{r} \frac{\partial \varphi}{\partial r} \right) - (1-2\nu) \frac{\partial^2 \varphi}{\partial z^2} \right\}.$$

A simpler form of e can be obtained if we use the Laplace equation

$$\frac{\partial^2 \varphi}{\partial r^2} + \frac{1}{r} \frac{\partial \varphi}{\partial r} + \frac{\partial^2 \varphi}{\partial z^2} = 0,$$

so that

$$e = \frac{1}{2\mu} \left\{ -z \left(\frac{\partial^3 \varphi}{\partial z^3} \right) + z \frac{\partial^3 \varphi}{\partial z^3} - (1-2\nu) \frac{\partial^2 \varphi}{\partial z^2} - (1-2\nu) \frac{\partial^2 \varphi}{\partial z^2} \right\} = -\frac{(1-2\nu)}{\mu} \frac{\partial^2 \varphi}{\partial z^2}.$$

(c) To obtain the stresses, we first obtain $\frac{2\mu\nu}{1-2\nu} e = -2\nu \frac{\partial^2 \varphi}{\partial z^2}$. Then we have

$$T_{rr} = \frac{2\mu\nu}{1-2\nu} e + 2\mu E_{rr} = -2\nu \frac{\partial^2 \varphi}{\partial z^2} + z \frac{\partial^3 \varphi}{\partial r^2 \partial z} + (1-2\nu) \frac{\partial^2 \varphi}{\partial r^2} = z \frac{\partial^3 \varphi}{\partial r^2 \partial z} + \frac{\partial^2 \varphi}{\partial r^2} + \frac{2\nu}{r} \frac{\partial \varphi}{\partial r},$$

$$T_{zz} = \frac{2\mu\nu}{1-2\nu} e + 2\mu E_{zz} = -2\nu \frac{\partial^2 \varphi}{\partial z^2} + \left(z \frac{\partial^3 \varphi}{\partial z^3} - (1-2\nu) \frac{\partial^2 \varphi}{\partial z^2} \right) = z \frac{\partial^3 \varphi}{\partial z^3} - \frac{\partial^2 \varphi}{\partial z^2},$$

$$T_{\theta\theta} = \frac{2\mu\nu}{1-2\nu} e + 2\mu E_{\theta\theta} = -2\nu \frac{\partial^2 \varphi}{\partial z^2} + \left(\frac{z}{r} \frac{\partial^2 \varphi}{\partial r \partial z} + (1-2\nu) \frac{1}{r} \frac{\partial \varphi}{\partial r} \right) = \frac{z}{r} \frac{\partial^2 \varphi}{\partial r \partial z} + 2\nu \frac{\partial^2 \varphi}{\partial r^2} + \frac{1}{r} \frac{\partial \varphi}{\partial r},$$

$$T_{rz} = 2\mu E_{rz} = z \frac{\partial^3 \varphi}{\partial r \partial z^2}, \quad T_{r\theta} = T_{\theta z} = 0.$$

Example 5.38.5

Consider the following potential functions in spherical coordinates (R, β, θ) for spherical symmetry problems:

$$\boldsymbol{\psi} = \psi(R)\mathbf{e}_R, \quad \phi = \phi(R), \quad (5.38.32)$$

where

$$\nabla^2 \phi = 0 \quad \text{and} \quad \nabla^2 \boldsymbol{\psi} = \mathbf{0}. \quad (5.38.33)$$

That is, [see Eqs. (2.35.37) and (2.35.40)]

$$\frac{d^2 \phi}{dR^2} + \frac{2}{R} \frac{d\phi}{dR} = 0 \quad \text{and} \quad \left(\frac{\partial^2 \psi}{\partial R^2} + \frac{2}{R} \frac{\partial \psi}{\partial R} - \frac{2\psi}{R^2} \right) = 0. \quad (5.38.34)$$

Obtain displacements, dilatation, and stresses, in spherical coordinates, generated by the given potential functions. We note that the spherical coordinates (R, β, θ) here corresponds to the spherical coordinates (r, θ, ϕ) in Section 2.35.

Solution

It can be obtained (see Prob. 5.80):

(a) Displacements:

$$2\mu u_R = \left(R \frac{d\psi}{dR} + (-3+4\nu)\psi + \frac{d\phi}{dR} \right), \quad u_\theta = u_\beta = 0. \quad (5.38.35)$$

(b) Dilatation:

$$e = -\frac{(1-2\nu)}{\mu} \left\{ \frac{d\psi}{dR} + \frac{2\psi}{R} \right\}. \quad (5.38.36)$$

(c) Stresses:

$$T_{RR} = (2\nu - 4) \frac{d\psi}{dR} + (2 - 4\nu) \frac{\psi}{R} + \frac{d^2\phi}{dR^2},$$

$$T_{\beta\beta} = T_{\theta\theta} = - \left\{ (2\nu - 1) \frac{d\psi}{dR} + \frac{3\psi}{R} - \frac{1}{R} \frac{d\phi}{dR} \right\},$$

$$T_{\beta\theta} = T_{R\theta} = T_{R\beta} = 0. \quad (5.38.38)$$

Example 5.38.6

Consider the following potential functions for axisymmetric problems:

$$\psi = 0, \quad \phi = \phi(r, z) = \hat{\phi}(R, \beta), \quad \nabla^2 \phi = \nabla^2 \hat{\phi} = 0, \quad (5.38.39)$$

where (r, θ, z) and (R, β, θ) are cylindrical and spherical coordinates, respectively, with z as the axis of symmetry. As in the previous example, the spherical coordinates (R, β, θ) here correspond to the spherical coordinates (r, θ, ϕ) in Section 2.35. Obtain displacements, dilatation, and stresses generated by the given potential functions in cylindrical and spherical coordinates.

Solution

It can be obtained (see Prob. 5.81):

In cylindrical coordinates:

(a) Displacements:

$$2\mu u_r = \frac{\partial \phi}{\partial r}, \quad u_\theta = 0, \quad 2\mu u_z = \frac{\partial \phi}{\partial z}. \quad (5.38.40)$$

(b) Dilatation:

$$e = 0. \quad (5.38.41)$$

(c) Stresses:

$$T_{rr} = \frac{\partial^2 \phi}{\partial r^2}, \quad T_{\theta\theta} = \frac{1}{r} \frac{\partial \phi}{\partial r}, \quad T_{zz} = \frac{\partial^2 \phi}{\partial z^2}, \quad T_{rz} = \frac{\partial^2 \phi}{\partial z \partial r}, \quad T_{r\theta} = T_{z\theta} = 0. \quad (5.38.42)$$

In spherical coordinates:

(a) Displacements:

$$2\mu u_R = \frac{\partial \hat{\phi}}{\partial R}, \quad u_\theta = 0, \quad 2\mu u_\beta = \frac{1}{R} \frac{\partial \hat{\phi}}{\partial \beta}. \quad (5.38.43)$$

(b) Dilatation:

$$e = 0. \quad (5.38.44)$$

(c) Stresses:

$$T_{RR} = \frac{\partial^2 \hat{\phi}}{\partial R^2}, \quad T_{\beta\beta} = \frac{1}{R} \left(\frac{1}{R} \frac{\partial^2 \hat{\phi}}{\partial \beta^2} + \frac{\partial \hat{\phi}}{\partial R} \right), \quad T_{\theta\theta} = \frac{1}{R} \left(\frac{\partial \hat{\phi}}{\partial R} + \frac{\cot \beta}{R} \frac{\partial \hat{\phi}}{\partial \beta} \right),$$

$$T_{R\beta} = \frac{1}{R} \left(\frac{\partial^2 \hat{\phi}}{\partial \beta \partial R} - \frac{1}{R} \frac{\partial \hat{\phi}}{\partial \beta} \right), \quad T_{R\theta} = T_{\theta\beta} = 0. \quad (5.38.45)$$

Example 5.38.7

Consider the following potential functions in spherical coordinates (R, β, θ) , for axisymmetric problems:

$$\psi = \psi(R, \beta)\mathbf{e}_z, \quad \phi = 0, \quad \text{where } \nabla^2 \psi = 0. \quad (5.38.46)$$

Obtain displacements, dilatation, and stresses in spherical coordinates, generated by the given potential functions.

Solution

It can be obtained (see Prob. 5.82):

(a) Displacements:

$$2\mu u_R = \left\{ R \frac{\partial \psi}{\partial R} - (3 - 4\nu)\psi \right\} \cos \beta, \quad 2\mu u_\beta = \left\{ (3 - 4\nu)\psi \sin \beta + \cos \beta \frac{\partial \psi}{\partial \beta} \right\}. \quad (5.38.47)$$

(b) Dilatation:

$$e = -\frac{(1 - 2\nu)}{\mu} \left(\cos \beta \frac{\partial \psi}{\partial R} - \frac{\sin \beta}{R} \frac{\partial \psi}{\partial \beta} \right). \quad (5.38.48)$$

(c) Stresses

$$T_{RR} = -2(1 - \nu) \cos \beta \frac{\partial \psi}{\partial R} + R \cos \beta \frac{\partial^2 \psi}{\partial R^2} + \frac{2\nu \sin \beta}{R} \frac{\partial \psi}{\partial \beta},$$

$$T_{\beta\beta} = (1 - 2\nu) \cos \beta \frac{\partial \psi}{\partial R} + (2 - 2\nu) \frac{\sin \beta}{R} \frac{\partial \psi}{\partial \beta} + \frac{\cos \beta}{R} \frac{\partial^2 \psi}{\partial \beta^2}, \quad (5.38.49)$$

$$T_{\theta\theta} = (1 - 2\nu) \frac{\partial \psi}{\partial R} \cos \beta + \left[(2\nu - 1) \sin \beta + \frac{1}{\sin \beta} \right] \frac{\partial \psi}{R \partial \beta},$$

$$T_{R\beta} = -\frac{2(1 - \nu)}{R} \cos \beta \frac{\partial \psi}{\partial \beta} + \cos \beta \frac{\partial^2 \psi}{\partial \beta \partial R} + \sin \beta (1 - 2\nu) \frac{\partial \psi}{\partial R}, \quad (5.38.50)$$

$$T_{R\theta} = T_{\theta\beta} = 0.$$

Example 5.38.8

Determine the constants A and B in the following potential functions so that they describe a uniform tensile field of intensity S where the only nonzero stress is $T_{zz} = S$:

$$\psi = \psi(r, z)\mathbf{e}_z = Bz\mathbf{e}_z, \quad \phi(r, z) = A \left(z^2 - \frac{r^2}{2} \right). \quad (5.38.51)$$

Solution

Combining the results of Example 5.38.3 and Example 5.38.6, we have

$$T_{rr} = \left\{ -2\nu \frac{\partial \psi}{\partial z} + z \frac{\partial^2 \psi}{\partial r^2} \right\} + \left(\frac{\partial^2 \phi}{\partial r^2} \right) = -2\nu B - A, \quad (5.38.52)$$

$$T_{\theta\theta} = \left\{ -2\nu \frac{\partial \psi}{\partial z} + \frac{z}{r} \frac{\partial \psi}{\partial r} \right\} + \frac{1}{r} \frac{\partial \phi}{\partial r} = -(2\nu B + A), \quad (5.38.53)$$

$$T_{zz} = -2(1-\nu)\frac{\partial\psi}{\partial z} + z\frac{\partial^2\psi}{\partial z^2} + \frac{\partial^2\phi}{\partial z^2} = -2(1-\nu)B + 2A, \quad (5.38.54)$$

$$T_{rz} = \left[-(1-2\nu)\frac{\partial\psi}{\partial r} + z\frac{\partial^2\psi}{\partial r\partial z} \right] + \frac{\partial^2\phi}{\partial z\partial r} = 0, \quad T_{r\theta} = T_{z\theta} = 0. \quad (5.38.55)$$

Let the uniform tension be parallel to the z direction with an intensity of S ; then

$$T_{zz} = S = -2(1-\nu)B + 2A, \quad T_{rr} = T_{\theta\theta} = 2\nu B + A = 0. \quad (5.38.56)$$

Solving the preceding equations, we have

$$A = \frac{\nu S}{1+\nu}, \quad B = -\frac{S}{2(1+\nu)}. \quad (5.38.57)$$

Thus,

$$\phi(r, z) = A\left(z^2 - \frac{r^2}{2}\right) = \frac{\nu S}{(1+\nu)}\left(z^2 - \frac{r^2}{2}\right), \quad \psi(z) = Bz = -\frac{S}{2(1+\nu)}z. \quad (5.38.58)$$

In spherical coordinates (R, β, θ) , where θ is the longitude angle and β is the angle between \mathbf{e}_z and \mathbf{e}_R , the functions in Eq. (5.38.58) become (*note*: $z = R \cos \beta$, $r = R \sin \beta$):

$$\hat{\phi}(R, \beta) = \frac{AR^2}{2}(3 \cos^2 \beta - 1) = \frac{\nu S}{2(1+\nu)}R^2(3 \cos^2 \beta - 1), \quad (5.38.59)$$

$$\hat{\psi}(R, \beta) = BR \cos \beta = -\frac{SR \cos \beta}{2(1+\nu)}. \quad (5.38.60)$$

The stresses in spherical coordinates can be obtained by using the results of Examples 5.38.6 and 5.38.7 and Eq. (5.38.56),

$$T_{RR} = -2(1-\nu)\cos\beta\frac{\partial\hat{\psi}}{\partial R} + R\cos\beta\frac{\partial^2\hat{\psi}}{\partial R^2} + \frac{2\nu\sin\beta}{R}\frac{\partial\hat{\psi}}{\partial\beta} + \frac{\partial^2\hat{\phi}}{\partial R^2} \quad (5.38.61)$$

$$= -2B(1-2\nu)\cos^2\beta + 3A\cos^2\beta - (2B\nu + A) = -2B(1-2\nu)\cos^2\beta + 3A\cos^2\beta,$$

$$T_{R\beta} = -\frac{2(1-\nu)}{R}\cos\beta\frac{\partial\hat{\psi}}{\partial\beta} + \cos\beta\frac{\partial^2\hat{\psi}}{\partial\beta\partial R} + \sin\beta(1-2\nu)\frac{\partial\hat{\psi}}{\partial R} + \frac{1}{R}\left(\frac{\partial^2\hat{\phi}}{\partial\beta\partial R} - \frac{1}{R}\frac{\partial\hat{\phi}}{\partial\beta}\right) \quad (5.38.62)$$

$$= \left\{ \frac{2BR(1-\nu)}{R} - B + (1-2\nu)B + \frac{1}{R}(-6AR + 3AR) \right\} \cos\beta\sin\beta$$

$$= \{-3A + 2B(1-2\nu)\} \cos\beta\sin\beta.$$

Example 5.38.9

- (a) Given $\phi_1 = [2z^2 - (x^2 + y^2)]$ and $\phi_2 = R^{-5}\phi_1$ in rectangular Cartesian coordinates, show that $\nabla^2\phi_1 = 0$ and $\nabla^2\phi_2 = 0$.
- (b) Express the ϕ 's in spherical coordinates $\phi(R, \beta, \theta)$.
- (c) For $\hat{\phi} = \phi_2$, what are the stresses in spherical coordinates?

Solution

$$(a) \nabla^2 \phi_1 = \frac{\partial^2 \phi_1}{\partial x^2} + \frac{\partial^2 \phi_1}{\partial y^2} + \frac{\partial^2 \phi_1}{\partial z^2} = -2 - 2 + 4 = 0.$$

$$\frac{\partial^2 \phi_2}{\partial x^2} = R^{-5} \frac{\partial^2 \phi_1}{\partial x^2} - 10x \frac{\partial \phi_1}{\partial x} R^{-7} - 5\phi_1 R^{-7} + 35\phi_1 x^2 R^{-9},$$

$$\frac{\partial^2 \phi_2}{\partial y^2} = R^{-5} \frac{\partial^2 \phi_1}{\partial y^2} - 10y \frac{\partial \phi_1}{\partial y} R^{-7} - 5\phi_1 R^{-7} + 35\phi_1 y^2 R^{-9},$$

$$\frac{\partial^2 \phi_2}{\partial z^2} = R^{-5} \frac{\partial^2 \phi_1}{\partial z^2} - 10z \frac{\partial \phi_1}{\partial z} R^{-7} - 5\phi_1 R^{-7} + 35\phi_1 z^2 R^{-9}.$$

Thus,

$$\begin{aligned} \nabla^2 \phi_2 &= -10 \left(x \frac{\partial \phi_1}{\partial x} + y \frac{\partial \phi_1}{\partial y} + z \frac{\partial \phi_1}{\partial z} \right) R^{-7} + 20\phi_1 R^{-7} \\ &= [-10(-2x^2 - 2y^2 + 4z^2) + 20(2z^2 - x^2 - y^2)] R^{-7} = 0. \end{aligned}$$

(b) Since $r = R \sin \beta$, $z = R \cos \beta$, therefore,

$$\begin{aligned} \phi_1 &= (2z^2 - r^2) = R^2(2 \cos^2 \beta - \sin^2 \beta) = R^2(3 \cos^2 \beta - 1), \\ \phi_2 &= R^{-3}(3 \cos^2 \beta - 1). \end{aligned} \tag{5.38.63}$$

(c) Using the results of Example 5.38.6, for $\hat{\phi} = \phi_2 = R^{-3}(3 \cos^2 \beta - 1)$, we have

$$T_{RR} = \frac{\partial^2 \hat{\phi}}{\partial R^2} = 12R^{-5}(3 \cos^2 \beta - 1), \tag{5.38.64}$$

$$T_{R\beta} = \frac{1}{R} \left(\frac{\partial^2 \hat{\phi}}{\partial \beta \partial R} - \frac{1}{R} \frac{\partial \hat{\phi}}{\partial \beta} \right) = 24R^{-5} \cos \beta \sin \beta, \tag{5.38.65}$$

$$T_{\theta\theta} = \frac{1}{R} \left(\frac{\partial \hat{\phi}}{\partial R} + \frac{\cot \beta}{R} \frac{\partial \hat{\phi}}{\partial \beta} \right) = -3R^{-5}(5 \cos^2 \beta - 1), \tag{5.38.66}$$

$$T_{\beta\beta} = \frac{1}{R} \left(\frac{1}{R} \frac{\partial^2 \hat{\phi}}{\partial \beta^2} + \frac{\partial \hat{\phi}}{\partial R} \right) = \left\{ -\frac{3}{2}(1 + 7 \cos 2\beta) R^{-4} \right\}. \tag{5.38.67}$$

Example 5.38.10

In cylindrical coordinates (r, θ, z) , let $z^* = z + it$ be a complex variable with $i = \sqrt{-1}$. Consider the potential function:

$$\varphi = z^* \log(R^* + z^*) - R^*, \quad R^{*2} = r^2 + z^{*2}. \tag{5.38.68}$$

(a) Show that

$$\nabla^2 \varphi = 0. \tag{5.38.69}$$

(b)

$$\begin{aligned} \operatorname{Im} \left(\frac{\partial \varphi}{\partial z} \right)_{z=0} &= \begin{cases} \pi/2 & \text{for } r \leq t, \\ \sin^{-1}(t/r) & \text{for } r \geq t. \end{cases} \\ \operatorname{Im} \left(\frac{\partial^2 \varphi}{\partial z^2} \right)_{z=0} &= \begin{cases} -\frac{1}{\sqrt{t^2 - r^2}} & \text{for } r < t, \\ 0 & \text{for } r > t. \end{cases} \end{aligned} \quad (5.38.70)$$

Solution(a) From $R^{*2} = r^2 + z^{*2}$, we have

$$\frac{\partial R^*}{\partial z^*} = \frac{z^*}{R^*}, \quad \frac{\partial R^*}{\partial r} = \frac{r}{R^*}, \quad \frac{\partial}{\partial z^*} \log(R^* + z^*) = \frac{1}{R^* + z^*} [(z^*/R^*) + 1] = 1/R^*$$

Thus,

$$\frac{\partial \varphi}{\partial z^*} = \log(R^* + z^*) + \left(\frac{z^*}{R^*} \right) - \frac{z^*}{R^*} = \log(R^* + z^*), \quad \frac{\partial^2 \varphi}{\partial z^{*2}} = \frac{1}{R^*},$$

$$\frac{\partial \varphi}{\partial r} = \left\{ \frac{z^*}{R^* + z^*} - 1 \right\} \left(\frac{r}{R^*} \right) = -\frac{r}{R^* + z^*},$$

$$\begin{aligned} \frac{\partial^2 \varphi}{\partial r^2} &= -\frac{1}{R^* + z^*} - \left(-\frac{r^2}{R^*(R^* + z^*)^2} \right) = -\frac{1}{R^* + z^*} \left\{ \frac{R^*(R^* + z^*) - r^2}{R^*(R^* + z^*)} \right\} \\ &= -\frac{1}{R^* + z^*} \frac{z^{*2} + R^*z^*}{R^*(R^* + z^*)}. \end{aligned}$$

That is,

$$\frac{\partial^2 \varphi}{\partial r^2} = -\frac{1}{R^* + z^*} \frac{z^*}{R^*}.$$

Thus,

$$\nabla^2 \varphi = \frac{\partial^2 \varphi}{\partial r^2} + \frac{1}{r} \frac{\partial \varphi}{\partial r} + \frac{\partial^2 \varphi}{\partial z^{*2}} = -\frac{z^*}{R^*(R^* + z^*)} - \frac{1}{R^* + z^*} + \frac{1}{R^*} = -\frac{1}{R^* + z^*} \left(\frac{z^*}{R^*} + 1 \right) + \frac{1}{R^*} = 0.$$

(b) At

$$z = 0, \quad z^* = it, \quad R^{*2} = r^2 + z^{*2} = r^2 - t^2, \quad \frac{\partial \varphi}{\partial z} = \frac{\partial \varphi}{\partial z^*} = \log(\sqrt{r^2 - t^2} + it).$$

Now,

$$\text{for } r \geq t, \quad \log(\sqrt{r^2 - t^2} + it) = \log r + i\alpha, \quad \alpha = \tan^{-1}(t/\sqrt{r^2 - t^2}) = \sin^{-1}(t/r),$$

$$\text{and for } r \leq t, \quad \log(\sqrt{r^2 - t^2} + it) = \log(i\sqrt{t^2 - r^2} + it) = \log(\sqrt{t^2 - r^2} + t) + i(\pi/2).$$

Thus, at $z=0$, $\operatorname{Im}\left(\frac{\partial\varphi}{\partial z}\right) = \begin{cases} \pi/2 & \text{for } r \leq t, \\ \sin^{-1}(t/r) & \text{for } r \geq t. \end{cases}$

(c) At

$$z = 0, \quad \frac{\partial^2\varphi}{\partial z^2} = \frac{\partial^2\varphi}{\partial z^{*2}} = \frac{1}{R^*} = \frac{1}{\sqrt{r^2 + (it)^2}} = \frac{1}{\sqrt{r^2 - t^2}}.$$

Thus, for

$$r > t, \quad \operatorname{Im}\frac{\partial^2\varphi}{\partial z^2} = \operatorname{Im}\frac{1}{\sqrt{r^2 - t^2}} = 0,$$

and for

$$r < t, \quad \operatorname{Im}\frac{\partial^2\varphi}{\partial z^2} = \operatorname{Im}\left\{-\frac{1}{\sqrt{t^2 - r^2}}i\right\} = -\frac{1}{\sqrt{t^2 - r^2}}.$$

That is,

$$\operatorname{Im}\left(\frac{\partial^2\varphi}{\partial z^2}\right) = \begin{cases} -\frac{1}{\sqrt{t^2 - r^2}} & \text{for } r < t, \\ 0 & \text{for } r > t. \end{cases}$$

5.39 KELVIN PROBLEM: CONCENTRATED FORCE AT THE INTERIOR OF AN INFINITE ELASTIC SPACE

Consider the following potential functions in cylindrical coordinates (r, θ, z) :

$$\psi = \psi(r, z)\mathbf{e}_z = (A/R)\mathbf{e}_z, \quad \phi = 0, \quad R^2 = r^2 + z^2. \quad (5.39.1)$$

Using the results obtained in Example 5.38.3, we easily obtain the displacements and the stresses as (see Prob. 5.84)

$$2\mu u_r = z \frac{\partial\psi}{\partial r} = -A \frac{rz}{R^3}, \quad u_\theta = 0, \quad 2\mu u_z = A \left[\frac{(-3 + 4\nu)}{R} - \frac{z^2}{R^3} \right], \quad (5.39.2)$$

$$T_{rr} = z \frac{\partial^2\psi}{\partial r^2} - 2\nu \frac{\partial\psi}{\partial z} = A \left[(2\nu - 1) \frac{z}{R^3} + \frac{3r^2z}{R^5} \right], \quad (5.39.3)$$

$$T_{\theta\theta} = \frac{z}{r} \frac{\partial\psi}{\partial r} - 2\nu \frac{\partial\psi}{\partial z} = A(2\nu - 1) \left(\frac{z}{R^3} \right), \quad (5.39.4)$$

$$T_{zz} = z \frac{\partial^2\psi}{\partial z^2} - 2(1 - \nu) \frac{\partial\psi}{\partial z} = A \left[\frac{3z^3}{R^5} + (1 - 2\nu) \left(\frac{z}{R^3} \right) \right], \quad (5.39.5)$$

$$T_{rz} = -(1 - 2\nu) \frac{\partial\psi}{\partial r} + z \frac{\partial^2\psi}{\partial r \partial z} = A \left[(1 - 2\nu) \left(\frac{r}{R^3} \right) + \left(\frac{3rz^2}{R^5} \right) \right], \quad T_{r\theta} = T_{\theta z} = 0. \quad (5.39.6)$$

We now show that the stress field given above is that in an elastic infinite space under the action of a concentrated force $\mathbf{F} = F_z \mathbf{e}_z$ at the origin if the constant A in the preceding equations is chosen to be

$$A = -\frac{F_z}{8\pi(1-\nu)}. \quad (5.39.7)$$

Consider a spherical volume of the medium with the origin at its center (Figure 5.39-1). Let the radius of the sphere be R_o . The stress vector acting on the spherical surface of the volume is given by $\mathbf{t} = \mathbf{T}\mathbf{n}$, where \mathbf{n} is the outward normal to the surface. The sphere is symmetrical about the z -axis; therefore, the normal vector depends only on α , the angle with which the normal make with the z -axis on every rz plane. That is (see Figure 5.39-1),

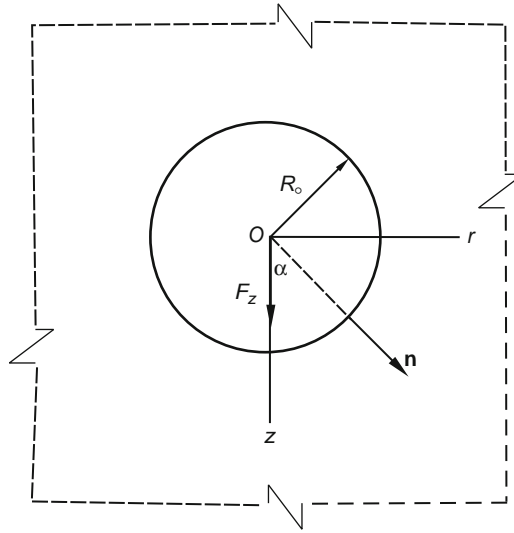

FIGURE 5.39-1

$$\mathbf{n} = \sin \alpha \mathbf{e}_r + \cos \alpha \mathbf{e}_z = \frac{r_o}{R_o} \mathbf{e}_r + \frac{z_o}{R_o} \mathbf{e}_z, \quad R_o^2 = r_o^2 + z_o^2. \quad (5.39.8)$$

Thus,

$$\begin{bmatrix} t_r \\ t_\theta \\ t_z \end{bmatrix} = \begin{bmatrix} T_{rr} & 0 & T_{rz} \\ 0 & T_{\theta\theta} & 0 \\ T_{zr} & 0 & T_{zz} \end{bmatrix} \begin{bmatrix} r_o/R_o \\ 0 \\ z_o/R_o \end{bmatrix} = \begin{bmatrix} T_{rr}(r_o/R_o) + T_{rz}(z_o/R_o) \\ 0 \\ T_{zr}(r_o/R_o) + T_{zz}(z_o/R_o) \end{bmatrix}. \quad (5.39.9)$$

Substituting the stresses, we obtain

$$t_r = -A \left\{ \left(\frac{(1-2\nu)z_o}{R_o^3} - \frac{3r_o^2 z_o}{R_o^5} \right) \left(\frac{r_o}{R_o} \right) - \left(\frac{(1-2\nu)r_o}{R_o^3} + \frac{3r_o z_o^2}{R_o^5} \right) \left(\frac{z_o}{R_o} \right) \right\} = A \left(\frac{3r_o z_o}{R_o^4} \right). \quad (5.39.10)$$

$$t_z = A \left(\frac{(1-2\nu)r_0}{R_0^3} + \frac{3r_0 z_0^2}{R_0^5} \right) \frac{r_0}{R_0} + A \left(\frac{3z_0^3}{R_0^5} + \frac{(1-2\nu)z_0}{R_0^3} \right) \frac{z_0}{R_0} = A \left\{ \frac{(1-2\nu)}{R_0^2} + \frac{3z_0^2}{R_0^4} \right\}. \quad (5.39.11)$$

Let us now calculate the resultant of these stress vector distributions on the spherical surface. We first note that due to axisymmetry of t_r , the resultant force in the r direction is clearly zero. The resultant force in the z direction is given by

$$\begin{aligned} F'_z &= \int t_z dS = \int_{\alpha=0}^{\pi} t_z (2\pi r_0) R_0 d\alpha = A(2\pi) \int_{\alpha=0}^{\pi} \left\{ \frac{(1-2\nu)}{R_0^2} + \frac{3z_0^2}{R_0^4} \right\} r_0 R_0 d\alpha \\ &= 2A\pi \int_{\alpha=0}^{\pi} \left\{ \frac{(1-2\nu)r_0}{R_0} + 3 \frac{z_0^2 r_0}{R_0^2 R_0} \right\} d\alpha \\ &= 2A\pi \int_{\alpha=0}^{\pi} \{ (1-2\nu) \sin \alpha + 3 \cos^2 \alpha \sin \alpha \} d\alpha \\ &= 2A\pi [-\cos^3 \alpha - (1-2\nu) \cos \alpha]_0^{\pi} = 2A\pi [2(2-2\nu)] = 8A\pi(1-\nu). \end{aligned} \quad (5.39.12)$$

That is,

$$F'_z = 8A\pi(1-\nu). \quad (5.39.13)$$

It is important to note that this resultant force, arising from the stress vector on the spherical surface, is independent of the radius of the sphere chosen. Thus, this resultant force remains exactly the same even when the sphere is infinitesimally small. In other words, this resultant force, acting on a sphere of any diameter, is balanced by a concentrated force F_z at the origin. That is,

$$F_z + F'_z = 0 \quad \text{or} \quad F_z = -F'_z = -8A\pi(1-\nu), \quad (5.39.14)$$

from which we have

$$A = -\frac{F_z}{8\pi(1-\nu)}. \quad (5.39.15)$$

In summary, the stress field for an elastic infinite space, subjected to a concentrated force of $\mathbf{F} = F_z \mathbf{e}_z$ at the origin, is given by

$$T_{rr} = \frac{F_z}{8\pi(1-\nu)} \left\{ (1-2\nu) \frac{z}{R^3} - \frac{3r^2 z}{R^5} \right\}, \quad T_{\theta\theta} = \frac{F_z}{8\pi(1-\nu)} \frac{(1-2\nu)z}{R^3}, \quad (5.39.16)$$

$$T_{zz} = -\frac{F_z}{8\pi(1-\nu)} \left[\frac{(1-2\nu)z}{R^3} + \frac{3z^3}{R^5} \right], \quad T_{rz} = -\frac{F_z}{8\pi(1-\nu)} \left\{ \frac{3rz^2}{R^5} + \frac{(1-2\nu)r}{R^3} \right\}, \quad (5.39.17)$$

$$T_{r\theta} = T_{\theta z} = 0. \quad (5.39.18)$$

and the displacement field is

$$u_r = \frac{F_z}{16\mu\pi(1-\nu)} \left(\frac{rz}{R^3} \right), \quad u_{\theta} = 0, \quad u_z = \frac{F_z}{16\mu\pi(1-\nu)} \left\{ \frac{(3-4\nu)}{R} + \frac{z^2}{R^3} \right\}. \quad (5.39.19)$$

5.40 BOUSSINESQ PROBLEM: NORMAL CONCENTRATED LOAD ON AN ELASTIC HALF-SPACE

First, let us consider the function

$$\varphi = C \ln(R + z), \quad R^2 = r^2 + z^2. \quad (5.40.1)$$

The following can be easily obtained:

$$\frac{\partial \varphi}{\partial r} = \frac{C}{R+z} \frac{r}{R}, \quad \frac{1}{r} \frac{\partial \varphi}{\partial r} = \frac{C}{R(R+z)}, \quad \frac{\partial^2 \varphi}{\partial r^2} = C \left\{ \frac{z}{R^3} - \frac{1}{R(R+z)} \right\}, \quad (i)$$

$$\frac{\partial \varphi}{\partial z} = \frac{C}{R+z} \left(\frac{z}{R} + 1 \right) = \frac{C}{R}, \quad \frac{\partial^2 \varphi}{\partial z^2} = -\frac{Cz}{R^3}, \quad \frac{\partial^2 \varphi}{\partial r \partial z} = -\frac{Cr}{R^3}, \quad (ii)$$

$$\frac{\partial^3 \varphi}{\partial r^2 \partial z} = C \left(\frac{3r^2}{R^5} - \frac{1}{R^3} \right), \quad \frac{\partial^3 \varphi}{\partial r \partial z^2} = C \left(\frac{3rz}{R^5} \right), \quad \frac{\partial^3 \varphi}{\partial z^3} = -C \left(\frac{1}{R^3} - \frac{3z^2}{R^5} \right). \quad (iii)$$

Clearly, $\nabla^2 \varphi(r, z) = \nabla^2 \ln(R + z) = 0$.

Now, let us consider the following potential functions:

$$\boldsymbol{\psi} = \frac{\partial \varphi}{\partial z} \mathbf{e}_z, \quad \phi = (1 - 2\nu)\varphi, \quad \text{where} \quad (5.40.2)$$

$$\varphi = C \ln(R + z), \quad R^2 = r^2 + z^2.$$

From the results of Example 5.38.4 and Eqs. (i), (ii) and (iii), we can obtain (see Prob. 5.86)

$$2\mu u_r = C \left[-\frac{rz}{R^3} + \frac{(1-2\nu)r}{R(R+z)} \right], \quad 2\mu u_z = -C \left[\frac{z^2}{R^3} + \frac{2(1-\nu)}{R} \right], \quad (5.40.3)$$

$$T_{rr} = C \left[\frac{3zr^2}{R^5} - \frac{(1-2\nu)}{R(R+z)} \right], \quad T_{\theta\theta} = C(1-2\nu) \left\{ -\frac{z}{R^3} + \frac{1}{R(R+z)} \right\}, \quad T_{zz} = C \frac{3z^3}{R^5}, \quad (5.40.4)$$

$$T_{rz} = C \frac{3rz^2}{R^5}, \quad T_{r\theta} = T_{\theta z} = 0. \quad (5.40.5)$$

We see that at $z=0$, $T_{zz} = T_{rz} = 0$, except at the origin. Thus, for a half-space $z \geq 0$, there is no surface traction on the surface $z=0$ except at the origin. We shall show that at the origin there is a concentrated force \mathbf{F} in the z -direction. Let us denote this force by

$$\mathbf{F} = F_z \mathbf{e}_z. \quad (5.40.6)$$

We can obtain F_z by considering the equilibrium of a very large circular disk ($r \rightarrow \infty$) of thickness h with origin at the top center of the disk. If this F_z turns out to be independent of h , then the stress field is that for a half-space under the action of a concentration force at the origin of the half-space. This is the so-called Boussinesq problem.

Since $T_{rz} \rightarrow 0$ at $r \rightarrow \infty$ [see Eq. (5.40.5)], there is no contribution from T_{rz} at the circular ring at large r (see Figure 5.40-1); therefore,

$$F_z + \int_{r=0}^{\infty} (T_{zz})_{z=h} (2\pi r) dr = 0. \quad (5.40.7)$$

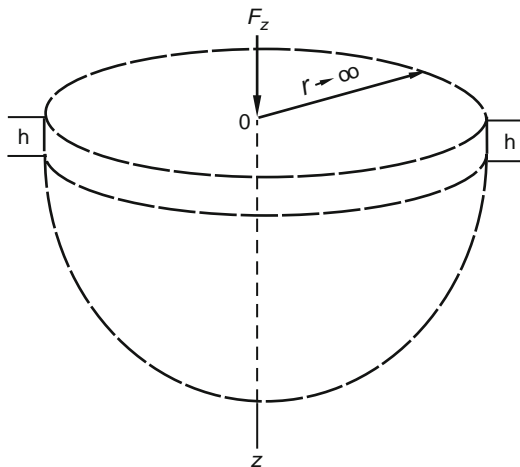

FIGURE 5.40-1

Thus,

$$F_z = - \int_{r=0}^{\infty} (T_{zz})_{z=h} (2\pi r) dr = -6C\pi h^3 \int_{r=0}^{\infty} \frac{r}{(r^2 + h^2)^{5/2}} dr = -6C\pi h^3 \left[-\frac{1}{3} (r^2 + h^2)^{-3/2} \right]_{r=0}^{\infty}.$$

That is,

$$F_z = -6C\pi h^3 \left(\frac{1}{3h^3} \right) = -2C\pi. \quad (5.40.8)$$

From which,

$$C = -\frac{F_z}{2\pi}. \quad (5.40.9)$$

Equation (5.40.9) shows that indeed F_z is independent of h . We also note that due to axisymmetry of the stresses, the force at the origin has only the axial component F_z . In summary, the stress field in the Boussinesq problem is

$$T_{rr} = -\frac{F_z}{2\pi} \left\{ \frac{3r^2 z}{R^3} - \frac{(1-2\nu)}{R(R+z)} \right\}, \quad T_{\theta\theta} = -\frac{F_z(1-2\nu)}{2\pi} \left\{ -\frac{z}{R^3} + \frac{1}{R(R+z)} \right\}, \quad (5.40.10)$$

$$T_{zz} = -\frac{F_z}{2\pi} \frac{3z^3}{R^3},$$

$$T_{rz} = -\frac{F_z}{2\pi} \frac{3rz^2}{R^3}, \quad T_{r\theta} = T_{\theta z} = 0, \quad (5.40.11)$$

and the displacement field is

$$u_r = \frac{F_z}{4\mu\pi} \left(\frac{rz}{R^3} - \frac{(1-2\nu)r}{(R+z)R} \right), \quad u_z = \frac{F_z}{4\mu\pi} \left(\frac{z^2}{R^3} + \frac{2(1-\nu)}{R} \right). \quad (5.40.12)$$

Example 5.40.1

For the Boussinesq problem, (a) obtain the displacement components in rectangular Cartesian components and (b) obtain the stress components in rectangular Cartesian components.

Solution

(a) With $u_\theta = 0$,

$$u_x = u_r \cos \theta = \frac{F_z}{4\mu\pi} \left(\frac{r \cos \theta z}{R^3} - \frac{(1-2\nu)r \cos \theta}{(R+z)R} \right) = \frac{F_z}{4\mu\pi} \left(\frac{xz}{R^3} - \frac{(1-2\nu)x}{(R+z)R} \right),$$

$$u_y = u_r \sin \theta = \frac{F_z}{4\mu\pi} \left(\frac{r \sin \theta z}{R^3} - \frac{(1-2\nu)r \sin \theta}{(R+z)R} \right) = \frac{F_z}{4\mu\pi} \left(\frac{yz}{R^3} - \frac{(1-2\nu)y}{(R+z)R} \right),$$

$$u_z = \frac{F_z}{4\mu\pi} \left(\frac{z^2}{R^3} + \frac{2(1-\nu)}{R} \right).$$

$$R^2 = x^2 + y^2 + z^2.$$

(b) From

$$\begin{bmatrix} T_{xx} & T_{xy} & T_{xz} \\ T_{yx} & T_{yy} & T_{yz} \\ T_{zx} & T_{zy} & T_{zz} \end{bmatrix} = \begin{bmatrix} \cos \theta & -\sin \theta & 0 \\ \sin \theta & \cos \theta & 0 \\ 0 & 0 & 1 \end{bmatrix} \begin{bmatrix} T_{rr} & 0 & T_{rz} \\ 0 & T_{\theta\theta} & 0 \\ T_{zr} & 0 & T_{zz} \end{bmatrix} \begin{bmatrix} \cos \theta & \sin \theta & 0 \\ -\sin \theta & \cos \theta & 0 \\ 0 & 0 & 1 \end{bmatrix},$$

we have (see Prob. 5.87 for details)

$$\begin{aligned} T_{xx} &= T_{rr} \cos^2 \theta + T_{\theta\theta} \sin^2 \theta \\ &= -\frac{3F_z x^2 z}{2\pi R^5} + \frac{F_z(1-2\nu)z}{2\pi R^3} - \frac{(1-2\nu)F_z}{2\pi R(R+z)} \left\{ 1 - \frac{x^2}{R^2} - \frac{x^2}{R(R+z)} \right\}, \end{aligned}$$

$$\begin{aligned} T_{yy} &= T_{rr} \sin^2 \theta + T_{\theta\theta} \cos^2 \theta \\ &= -\frac{3F_z y^2 z}{2\pi R^5} + \frac{F_z(1-2\nu)z}{2\pi R^3} - \frac{(1-2\nu)F_z}{2\pi R(R+z)} \left\{ 1 - \frac{y^2}{R^2} - \frac{y^2}{R(R+z)} \right\}, \end{aligned}$$

$$T_{xz} = T_{rz} \cos \theta = -\frac{F_z 3rz^2}{2\pi R^5} \cos \theta = -\frac{F_z 3xz^2}{2\pi R^5},$$

$$T_{yz} = T_{rz} \sin \theta = -\frac{F_z 3yz^2}{2\pi R^5},$$

$$\begin{aligned} T_{xy} &= (T_{rr} - T_{\theta\theta}) \sin \theta \cos \theta = -\frac{F_z 3xyz}{2\pi R^5} + \frac{F_z(1-2\nu)}{2\pi} \left(\frac{2}{R(R+z)} - \frac{z}{R^3} \right) \frac{xy}{(R^2 - z^2)} \\ &= -\frac{F_z 3xyz}{2\pi R^5} + \frac{F_z(1-2\nu)}{2\pi} \left(\frac{1}{R^2(R+z)} + \frac{1}{R^3} \right) \frac{xy}{(R+z)}, \end{aligned}$$

$$T_{zz} = -\frac{F_z 3z^3}{2\pi R^5}.$$

5.41 DISTRIBUTIVE NORMAL LOAD ON THE SURFACE OF AN ELASTIC HALF-SPACE

From the solution of the Boussinesq problem in Cartesian coordinates (Example 5.40.1), the solution to the problem of a distributive normal load acting on the surface of an elastic half-space can be obtained by the method of superposition. Let $q(x, y)$ denote the normal load per unit area on the surface. The contribution from the differential load $q(x', y')dx'dy'$ at $(x', y', 0)$, to the vertical displacement u_z (see Figure 5.41-1), is

$$du_z = \frac{q(x', y')}{4\mu\pi R'} \left\{ 2(1 - \nu) + \frac{(z - 0)^2}{R'^2} \right\} dx'dy', \quad R'^2 = (x - x')^2 + (y - y')^2 + (z - 0)^2. \quad (5.41.1)$$

Thus,

$$u_z = \frac{1}{4\mu\pi} \left\{ 2(1 - \nu) \int \frac{q(x', y')}{R'} dx'dy' + z^2 \int \frac{q(x', y')}{R'^3} dx'dy' \right\}. \quad (5.41.2)$$

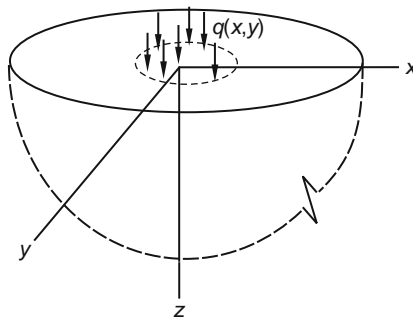

FIGURE 5.41-1

Similarly,

$$T_{zz} = -\frac{3z^3}{2\pi} \int \frac{q(x', y')}{R'^5} dx'dy'. \quad (5.41.3)$$

Example 5.41.1

Obtain the variation of u_z along the z -axis for the case where the normal load on the surface is uniform with intensity q_0 and the loaded area is a circle of radius r_0 with its center at the origin (see Figure 5.41-2).

Solution

Using Eq. (5.41.2), we have

$$u_z = \frac{q_0(1 - \nu)}{2\mu\pi} \int \frac{1}{R'} 2\pi r' dr' + \frac{q_0}{4\mu\pi} z^2 \int \frac{1}{R'^3} 2\pi r' dr' = \frac{q_0(1 - \nu)}{\mu} \int \frac{r' dr'}{R'} + \frac{q_0 z^2}{2\mu} \int \frac{r' dr'}{R'^3}, \quad (i)$$

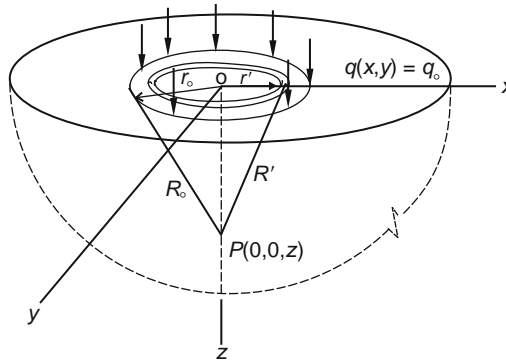

FIGURE 5.41-2

where $R'^2 = r'^2 + z^2$ and $R'dR' = r'dr'$. Thus,

$$u_z = \frac{q_0(1-\nu)}{\mu} \int_z^{R_0} dR' + \frac{q_0 z^2}{2\mu} \int_z^{R_0} \frac{dR'}{R'^2}, \quad R_0^2 = r_0^2 + z^2. \quad (\text{ii})$$

That is,

$$u_z = \frac{q_0(1-\nu)}{\mu} \left(\sqrt{r_0^2 + z^2} - z \right) - \frac{q_0 z^2}{2\mu \sqrt{r_0^2 + z^2}} + \frac{q_0 z}{2\mu}. \quad (5.41.4)$$

In particular, at the center of the loaded area, $z=0$,

$$u_z = \frac{q_0(1-\nu)r_0}{\mu}. \quad (5.41.5)$$

5.42 HOLLOW SPHERE SUBJECTED TO UNIFORM INTERNAL AND EXTERNAL PRESSURE

In spherical coordinates (R, β, θ) , where β is the angle between \mathbf{e}_z and \mathbf{e}_R and θ is the longitude angle, consider the following potential functions for spherical symmetric problems:

$$\psi = BR\mathbf{e}_R, \quad \phi = \frac{A}{R}, \quad A \text{ and } B \text{ are constants.} \quad (5.42.1)$$

From Example 5.38.5, we have the following nonzero stress components:

$$T_{RR} = -2 \left\{ (2-\nu) \frac{d\psi}{dR} + (2\nu-1) \frac{\psi}{R} - \frac{d^2\phi}{2dR^2} \right\} = -2(1+\nu)B + 2 \frac{A}{R^3}, \quad (5.42.2)$$

$$T_{\beta\beta} = T_{\theta\theta} = - \left\{ (2\nu-1) \frac{d\psi}{dR} + \frac{3\psi}{R} - \frac{1}{R} \frac{d\phi}{dR} \right\} = -2(1+\nu)B - \frac{A}{R^3}, \quad (5.42.3)$$

and the following displacement components:

$$2\mu u_{RR} = R \frac{d\psi}{dR} + (-3 + 4\nu)\psi + \frac{d\phi}{dR} = 2(2\nu - 1)BR - \frac{A}{R^2}, \quad u_\beta = u_\theta = 0. \quad (5.42.4)$$

Let the internal and external uniform pressure be denoted by p_i and p_o , respectively, then the boundary conditions are

$$T_{RR} = -p_i \quad \text{at internal radius} \quad R = R_i, \quad (5.42.5)$$

and

$$T_{RR} = -p_o \quad \text{at external radius} \quad R = R_o. \quad (5.42.6)$$

Thus,

$$-2(1 + \nu)B + \frac{2A}{R_i^3} = -p_i, \quad -2(1 + \nu)B + \frac{2A}{R_o^3} = -p_o, \quad (5.42.7)$$

from which we have

$$2A = (-p_i + p_o) \frac{R_i^3 R_o^3}{R_o^3 - R_i^3}, \quad 2(1 + \nu)B = \frac{p_o R_o^3 - R_i^3 p_i}{R_o^3 - R_i^3}. \quad (5.42.8)$$

If $p_i = 0$, then

$$T_{RR} = \frac{p_o R_o^3}{R_i^3 - R_o^3} - \left(\frac{p_o R_i^3 R_o^3}{R_i^3 - R_o^3} \right) \frac{1}{R^3}, \quad (5.42.9)$$

$$T_{\theta\theta} = T_{\beta\beta} = \frac{p_o R_o^3}{R_i^3 - R_o^3} + \left(\frac{p_o R_i^3 R_o^3}{R_i^3 - R_o^3} \right) \frac{1}{2R^3}. \quad (5.42.10)$$

5.43 SPHERICAL HOLE IN A TENSILE FIELD

We want to obtain the stress field in an elastic medium with a spherical hole of radius $R = a$ at the origin with $T_{zz} = S e_z$ far from the hole (see Figure 5.43-1).

In spherical coordinates, a uniform tensile field with $T_{zz} = S e_z$ is given by the potentials [see Eqs. (5.38.59) and (5.38.60) in Example 5.38.8]:

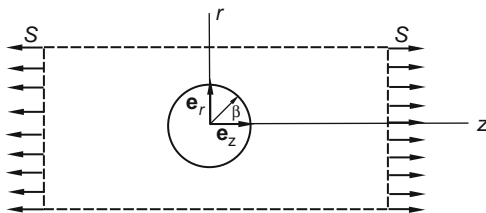

FIGURE 5.43-1

$$\begin{aligned}\psi &= -\frac{SR \cos \beta}{2(1+\nu)} \mathbf{e}_z, \\ \phi &= \frac{\nu SR^2}{2(1+\nu)} (3 \cos^2 \beta - 1).\end{aligned}\quad (5.43.1)$$

Corresponding to which, the stresses are [see Eqs. (5.38.61) and (5.38.62)]:

$$\begin{aligned}T'_{RR} &= -2B(1-2\nu) \cos^2 \beta + 3A \cos^2 \beta, & T'_{R\beta} &= \{-3A + 2B(1-2\nu)\} \cos \beta \sin \beta, \\ T'_{R\theta} &= 0,\end{aligned}\quad (5.43.2)$$

where

$$A = \frac{\nu S}{1+\nu}, \quad B = -\frac{S}{2(1+\nu)}.\quad (5.43.3)$$

We look for a disturbed field that vanishes at large distance but that eliminates the stress vector due to Eq. (5.43.2) on the surface of the spherical hole. The following potentials generate stresses that vanish at $R \rightarrow \infty$:

$$\tilde{\phi} = \tilde{\phi}(R, \beta) = C_1 R^{-3} (3 \cos^2 \beta - 1) / 2 + C_2 R^{-1}, \quad \tilde{\psi} = D_1 R^{-2} \cos \beta \mathbf{e}_z.\quad (5.43.4)$$

It is easy to verify that the three functions R^{-1} , $R^{-2} \cos \beta$ and $R^{-3} (3 \cos^2 \beta - 1)$ all satisfy the Laplace equation. The stresses generated by them are (see Probs. 5.89 and 5.90)

$$\tilde{T}_{RR} = 6C_1 R^{-5} (3 \cos^2 \beta - 1) + 2C_2 R^{-3} + 2(5-\nu)D_1 R^{-3} \cos^2 \beta - 2D_1 \nu R^{-3},\quad (5.43.5)$$

$$\tilde{T}_{\beta R} = 12C_1 R^{-5} \cos \beta \sin \beta + 2D_1 R^{-3} (1+\nu) \cos \beta \sin \beta,\quad (5.43.6)$$

$$\tilde{T}_{R\theta} = 0.\quad (5.43.7)$$

Combining the uniform field Eq. (5.43.2) with the preceding disturbed field, we have

$$\begin{aligned}T_{RR} &= [-2B(1-2\nu) + 3A + 18C_1 R^{-5} + 2D_1 R^{-3} (5-\nu)] \cos^2 \beta \\ &\quad - 6C_1 R^{-5} + 2C_2 R^{-3} - 2\nu D_1 R^{-3},\end{aligned}\quad (5.43.8)$$

$$T_{R\beta} = [-3A + 2B(1-2\nu) + 12C_1 R^{-5} + 2D_1 R^{-3} (1+\nu)] \cos \beta \sin \beta,\quad (5.43.9)$$

$$T_{R\theta} = 0.\quad (5.43.10)$$

We now apply the boundary condition that, on the surface of the spherical cavity, the stress vector is zero. That is, at $R = a$, we demand that

$$(T_{RR})_{R=a} = (T_{R\beta})_{R=a} = (T_{R\theta})_{R=a} = 0.\quad (5.43.11)$$

These conditions lead to

$$\begin{aligned}3A - 2B(1-2\nu) + 18C_1 a^{-5} + 2D_1 a^{-3} (5-\nu) &= 0, \\ -6C_1 a^{-5} + 2C_2 a^{-3} - 2\nu D_1 a^{-3} &= 0, \\ -3A + 2B(1-2\nu) + 12C_1 a^{-5} + 2D_1 a^{-3} (1+\nu) &= 0,\end{aligned}\quad (5.43.12)$$

where A and B are given in Eq. (5.43.3). Solving the preceding three equations for the unknowns C_1 , C_2 and D_1 , we have

$$C_1 = \frac{Sa^5}{7-5\nu}, \quad C_2 = \frac{Sa^3(6-5\nu)}{2(7-5\nu)}, \quad D_1 = -\frac{5Sa^3}{2(7-5\nu)}. \quad (5.43.13)$$

From the preceding results, one can obtain the maximum tensile stress

$$(T_{\beta\beta})_{\max} = \frac{3S(9-5\nu)}{2(7-5\nu)} \quad \text{at } \beta = \pi/2 \quad \text{and} \quad R = a. \quad (5.43.14)$$

5.44 INDENTATION BY A RIGID FLAT-ENDED SMOOTH INDENTER ON AN ELASTIC HALF-SPACE

Let the half-space be defined by $z \geq 0$ and let a be the radius of the indenter. The boundary conditions for this problem are as follows (see Figure 5.44-1):

At $z = 0$, the vertical displacement is a constant within the indenter end, i.e.,

$$u_z = w_0 \quad \text{for } r \leq a, \quad (5.44.1)$$

and there is zero stress vector outside the indenter, i.e.,

$$T_{zz} = T_{rz} = T_{\theta z} = 0 \quad \text{for } r > a. \quad (5.44.2)$$

In the following we show that the potential functions lead to a displacement field and a stress field that satisfy the preceding conditions:

$$\psi = \left(\frac{\partial F}{\partial z} \right) \mathbf{e}_z, \quad \phi = (1-2\nu)F, \quad (5.44.3)$$

where

$$F = \text{Im } \varphi(r, z), \quad \varphi(r, z) = A[z^* \log(R^* + z^*) - R^*], \quad (5.44.4)$$

$$R^{*2} = r^2 + z^{*2}, \quad z^* = z + it$$

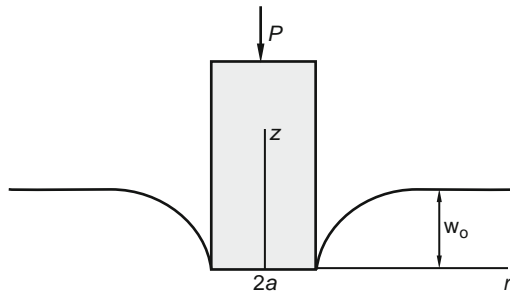

FIGURE 5.44-1

From Example 5.38.4, we have, for the potential functions given in Eq. (5.44.3),

$$2\mu u_z = z \frac{\partial^2 F}{\partial z^2} + (-2+2\nu) \frac{\partial F}{\partial z}, \quad T_{zz} = z \frac{\partial^3 F}{\partial z^3} - \frac{\partial^2 F}{\partial z^2}, \quad T_{rz} = z \frac{\partial^3 F}{\partial r \partial z^2}, \quad T_{\theta z} = 0. \quad (5.44.5)$$

Thus, on $z=0$

$$2\mu u_z = -2(1-\nu)\left(\frac{\partial F}{\partial z}\right), \quad T_{zz} = -\left(\frac{\partial^2 F}{\partial z^2}\right), \quad T_{rz} = T_{\theta z} = 0. \quad (5.44.6)$$

Now, from $F = \text{Im } \varphi(r, z)$, we have

$$\frac{\partial F}{\partial z} = \frac{\partial}{\partial z} \text{Im } \varphi(r, z) = \text{Im } \frac{\partial \varphi(r, z)}{\partial z}, \quad \frac{\partial^2 F}{\partial z^2} = \text{Im } \frac{\partial^2 \varphi(r, z)}{\partial z^2}. \quad (5.44.7)$$

Thus, for the $\varphi(r, z)$ given in Eq. (5.44.4), we have (see Example 5.38.10), on $z=0$,

$$2\mu u_z|_{z=0} = -2(1-\nu)\text{Im}\left(\frac{\partial \varphi}{\partial z}\right)_{z=0} = -2A(1-\nu) \begin{cases} \pi/2 & \text{for } r \leq t, \\ \sin^{-1}(t/r) & \text{for } r \geq t. \end{cases} \quad (5.44.8)$$

and

$$T_{zz}|_{z=0} = -\text{Im}\left(\frac{\partial^2 \varphi}{\partial z^2}\right)_{z=0} = \begin{cases} \frac{A}{\sqrt{t^2 - r^2}} & \text{for } r < t, \\ 0 & \text{for } r > t. \end{cases} \quad (5.44.9)$$

Now, if we identify the parameter t as the radius a , then we have

$$u_z = -\frac{A(1-\nu)\pi}{2\mu}, \quad T_{zz} = \frac{A}{\sqrt{a^2 - r^2}}, \quad \text{for } r < a. \quad (5.44.10)$$

With w_0 denoting the depth of penetration, i.e., $u_z = w_0$ for $r \leq a$, [see Eq. (5.44.1)], we have

$$A = -\frac{2\mu w_0}{(1-\nu)\pi}. \quad (5.44.11)$$

Therefore, the normal stress distribution under the flat-ended indenter is

$$T_{zz} = -\frac{2\mu w_0}{(1-\nu)\pi} \frac{1}{\sqrt{a^2 - r^2}}, \quad \text{for } r < a. \quad (5.44.12)$$

The total load exerted by the indenter on the half-space is given by

$$P = -\int_0^a T_{zz}(2\pi r)dr = \frac{4\mu w_0}{(1-\nu)} \int_0^a \frac{rdr}{\sqrt{a^2 - r^2}} = \frac{4\mu w_0 a}{(1-\nu)}. \quad (5.44.13)$$

Thus, in terms of the total load P , the depth of penetration is given by

$$w_0 = \frac{P(1-\nu)}{4\mu a}, \quad (5.44.14)$$

the normal stress under the flat-ended indenter is given by

$$T_{zz} = -\frac{P}{2\pi a} \frac{1}{\sqrt{a^2 - r^2}}, \quad \text{for } r < a, \quad (5.44.15)$$

and the vertical displacement of the surface outside the indenter is given by [see Eq. (5.44.8)]

$$u_z = \frac{2w_0}{\pi} \sin^{-1}(a/r) = \frac{P(1-\nu)}{2\pi\mu a} \sin^{-1}(a/r), \quad \text{for } r > a. \quad (5.44.16)$$

5.45 INDENTATION BY A SMOOTH RIGID SPHERE ON AN ELASTIC HALF-SPACE

We begin by first discussing the general case of an axisymmetric indenter. Let the half-space be defined by $z \geq 0$ and let the profile of the rigid indenter be defined by $w_0 + w(r)$. Due to axisymmetry, the area of contact between the elastic space and the rigid indenter is a circle of radius a , whose magnitude depends on the indenter load P . The boundary conditions for this problem are as follows:

At $z = 0$, the vertical displacement is given by

$$u_z = w_0 + w(r) \quad \text{for } r \leq a, \quad (5.45.1)$$

and there is zero stress vector outside the indenter, i.e.,

$$T_{zz} = T_{rz} = T_{\theta z} = 0 \quad \text{for } r \geq a. \quad (5.45.2)$$

In the following we show that the potential functions lead to a displacement field and a stress field that satisfy the preceding conditions:

$$\psi = \left(\frac{\partial F}{\partial z} \right) \mathbf{e}_z, \quad \phi = (1 - 2\nu)F, \quad (5.45.3)$$

where

$$F = \text{Im } \varphi(r, z), \quad \varphi = \int_0^a f(t) [z^* \log(R^* + z^*) - R^*] dt, \quad (5.45.4)$$

$$R^{*2} = r^2 + z^{*2}, \quad z^* = z + it.$$

In Example 5.38.10, we obtained that if $\varphi(r, z) = A[z^* \log(R^* + z^*) - R^*]$, then

$$\text{Im} \left(\frac{\partial \varphi}{\partial z} \right)_{z=0} = \begin{cases} \pi/2 & \text{for } r \leq t \\ \sin^{-1}(t/r) & \text{for } r \geq t \end{cases} \quad \text{and} \quad \text{Im} \left(\frac{\partial^2 \varphi}{\partial z^2} \right)_{z=0} = \begin{cases} -\frac{1}{\sqrt{t^2 - r^2}} & \text{for } r < t, \\ 0 & \text{for } r > t. \end{cases}$$

Thus, for $\varphi = \int_0^a f(t) [z^* \log(R^* + z^*) - R^*] dt$, we have

For $r \geq a$,

$$\text{Im} \left(\frac{\partial \varphi}{\partial z} \right)_{z=0} = \int_{t=0}^a f(t) \sin^{-1}(t/r) dt. \quad (5.45.5)$$

For $r \leq a$,

$$\text{Im} \left(\frac{\partial \varphi}{\partial z} \right)_{z=0} = \int_{t=0}^r f(t) \sin^{-1}(t/r) dt + \int_{t=r}^a (\pi/2) f(t) dt, \quad (5.45.6)$$

or, since

$$\sin^{-1}(t/r) = (\pi/2) - \cos^{-1}(t/r), \quad (5.45.7)$$

Eq. (5.45.6) can also be written as

For $r \leq a$,

$$\text{Im} \left(\frac{\partial \varphi}{\partial z} \right)_{z=0} = (\pi/2) \int_{t=0}^a f(t) dt - \int_{t=0}^r f(t) \cos^{-1}(t/r) dt. \quad (5.45.8)$$

We also have:

For $r \geq a$,

$$\operatorname{Im}\left(\frac{\partial^2 \varphi}{\partial z^2}\right)_{z=0} = \int_{t=0}^a (0)f(t)dt = 0. \quad (5.45.9)$$

For $r \leq a$,

$$\operatorname{Im}\left(\frac{\partial^2 \varphi}{\partial z^2}\right)_{z=0} = \int_{t=0}^r (0)f(t)dt + \int_{t=r}^a \left\{ -\frac{1}{\sqrt{t^2 - r^2}} \right\} f(t)dt = - \int_{t=r}^a \left\{ \frac{f(t)}{\sqrt{t^2 - r^2}} \right\} dt. \quad (5.45.10)$$

Thus, similar to the case for a flat indenter:

For $r \geq a$,

$$2\mu u_z|_{z=0} = -2(1-\nu)\operatorname{Im}\left(\frac{\partial \varphi}{\partial z}\right)_{z=0} = -2(1-\nu) \int_{t=0}^a f(t) \sin^{-1}(t/r)dt, \quad (5.45.11)$$

For $r \leq a$,

$$\begin{aligned} 2\mu u_z|_{z=0} &= -2(1-\nu)\operatorname{Im}\left(\frac{\partial \varphi}{\partial z}\right)_{z=0} \\ &= -2(1-\nu) \left[\frac{\pi}{2} \int_{t=0}^a f(t)dt - \int_{t=0}^r f(t) \cos^{-1}(t/r)dt \right]. \end{aligned} \quad (5.45.12)$$

From this equation, we have, with the profile of the indenter given by $w = w_o + w(r)$, the following integral equation for the determination of the function $f(t)$:

$$w_o + w(r) = -\frac{(1-\nu)}{\mu} \left[\frac{\pi}{2} \int_{t=0}^a f(t)dt - \int_{t=0}^r f(t) \cos^{-1}(t/r)dt \right]. \quad (5.45.13)$$

The normal stress inside the contact region is given by

$$T_{zz} = -\operatorname{Im}\left(\frac{\partial^2 \varphi}{\partial z^2}\right)_{z=0} = \int_{t=r}^a \left\{ \frac{f(t)}{\sqrt{t^2 - r^2}} \right\} dt \quad \text{for } r < a, \quad (5.45.14)$$

so that the total load exerted by the indenter on the elastic half-space is given by

$$P = \int_0^a (-T_{zz})_{z=0} 2\pi r dr = -2\pi \int_0^a r \left\{ \int_{t=r}^a \frac{f(t)dt}{\sqrt{t^2 - r^2}} \right\} dr. \quad (5.45.15)$$

Interchanging the order of differentiation, we have

$$P = -2\pi \int_{t=0}^a f(t) \left\{ \int_{r=0}^t \frac{r dr}{\sqrt{t^2 - r^2}} \right\} dt = -2\pi \int_{t=0}^a t f(t) dt. \quad (5.45.16)$$

It can be verified (see Appendix 5A.1) that for a given $w_o + w(r)$, the solution to the unknown $f(t)$ in the integral equation Eq. (5.45.13) is given by

$$f(t) = B\delta(a-t) + \frac{2\mu}{(1-\nu)\pi} \frac{1}{t} \frac{d}{dt} \int_{r=0}^t \frac{dw}{dr} \frac{r^2 dr}{\sqrt{t^2 - r^2}}, \quad (5.45.17)$$

where the Dirac function $\delta(a-t)$ is zero except at $t=a$, when it becomes unbounded in such a way that the integral $\int_{t=0}^a \delta(a-t)dt = 1$.

Example 5.45.1

Use the equation derived in this section to solve the flat-ended indenter problem of the previous section.

Solution

For a flat-ended indenter, $dw/dr = 0$, so that from Eq. (5.45.17), we have

$$f(t) = B\delta(a - t), \quad (5.45.18)$$

where a , the contact radius, is the radius of the flat-ended indenter. With $f(t)$ given by the preceding equation, Eq. (5.45.13) becomes

$$w_o = -\frac{(1-\nu)B}{\mu} \left[\frac{\pi}{2} \int_{t=0}^a \delta(a-t) dt - \int_{t=0}^r \delta(a-t) \cos^{-1}(t/r) dt \right]. \quad (5.45.19)$$

The first integral within the bracket is unity. The second integral is zero because $\delta(a-t) = 0$ for $r < a$, $\cos^{-1}(a/a) = \cos^{-1}(1) = 0$, so that $\int_{t=0}^r \delta(a-t) \cos^{-1}(t/r) dt = 0$ for all $r \leq a$. Thus, Eq. (5.45.19) gives $w_o = -(1-\nu)B\pi/2\mu$, so that

$$B = -\frac{2\mu w_o}{(1-\nu)\pi}. \quad (5.45.20)$$

Now, from Eq. (5.45.16),

$$P = -2\pi B \int_{t=0}^a t\delta(a-t) dt = \frac{4\mu w_o}{(1-\nu)} \int_{t=0}^a t\delta(a-t) dt = \frac{4\mu a}{(1-\nu)} w_o, \quad (5.45.21)$$

from which we obtain the same penetration depth as given in Eq. (5.44.14) of the previous section.

$$w_o = \frac{P(1-\nu)}{4\mu a}. \quad (5.45.22)$$

Also, from Eqs. (5.45.14), (5.45.18), (5.45.20) and (5.45.22), the normal stress within the contact region $r < a$ is given by:

$$T_{zz} = B \int_{t=r}^a \frac{\delta(a-t)}{\sqrt{t^2 - r^2}} dt = \frac{B}{\sqrt{a^2 - r^2}} = -\frac{P}{2\pi a\sqrt{a^2 - r^2}}. \quad (5.45.23)$$

The same result was obtained in the last section.

We now discuss the case of a smooth rigid spherical indenter. Referring to Figure 5.45-1, the vertical surface displacement within the contact region is given by:

$$u_z(r) = w_o - [R - (R^2 - r^2)^{1/2}] = w_o - R + R(1 - r^2/R^2)^{1/2}, \quad (5.45.24)$$

where R is the radius of the sphere and r is the cylindrical coordinate. We shall assume that the contact region is small so that $r/R \ll 1$; then

$$\left(1 - \frac{r^2}{R^2}\right)^{1/2} \approx 1 - \frac{r^2}{2R^2}, \quad (5.45.25)$$

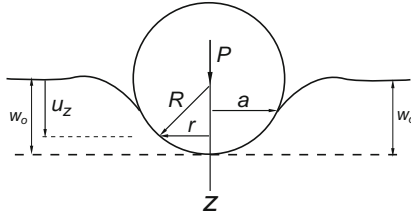

FIGURE 5.45-1

so that

$$u_z(r) = w_0 - \frac{r^2}{2R}. \quad (5.45.26)$$

Thus [see Eq. (5.45.1)], we have

$$w(r) = -\frac{r^2}{2R} \quad \text{and} \quad \frac{dw}{dr} = -\frac{r}{R}. \quad (5.45.27)$$

Equation (5.45.17) then gives:

$$f(t) = B\delta(a-t) - \frac{2\mu}{R(1-\nu)\pi} \frac{1}{t} \frac{d}{dt} \int_{r=0}^t \frac{r^3 dr}{\sqrt{t^2-r^2}}. \quad (5.45.28)$$

By letting $r = t \cos \theta$, we can easily obtain

$$\int_{r=0}^t \frac{r^3 dr}{\sqrt{t^2-r^2}} = -t^3 \int_{\theta=\pi/2}^0 \cos^3 \theta d\theta = \frac{2t^3}{3}. \quad (5.45.29)$$

Thus,

$$f(t) = B\delta(a-t) - \frac{4\mu}{R(1-\nu)\pi} t. \quad (5.45.30)$$

The contact normal stress is then given by [see Eq. (5.45.14)]

$$T_{zz} = \int_{t=r}^a \left\{ \frac{f(t)}{\sqrt{t^2-r^2}} \right\} dt = B \int_{t=r}^a \frac{\delta(a-t) dt}{\sqrt{t^2-r^2}} - \frac{4\mu}{R(1-\nu)\pi} \int_{t=r}^a \frac{t dt}{\sqrt{t^2-r^2}}. \quad (5.45.31)$$

The first integral in the right-hand side gives

$$B \int_{t=r}^a \frac{\delta(a-t) dt}{\sqrt{t^2-r^2}} = \frac{B}{\sqrt{a^2-r^2}}, \quad (5.45.32)$$

where the parameter a is the contact radius between the spherical indenter and the elastic half-space, which is still to be determined as a function of the load P . At $r = a$, the indenter separates smoothly from the half-space in such a way that the normal stress at this point is zero. (This is different from the case of a flat-ended indenter, where the surface has a sharp curvature at the separation point.) Thus, $B = 0$ and we have

$$f(t) = -\frac{4\mu}{R(1-\nu)\pi} t, \quad (5.45.33)$$

so that Eq. (5.45.31) becomes

$$T_{zz} = -\frac{4\mu}{R(1-\nu)\pi} \int_{t=r}^a \frac{tdt}{\sqrt{t^2-r^2}} = -\frac{4\mu}{R(1-\nu)\pi} \left[\sqrt{t^2-r^2} \right]_{t=r}^a = -\frac{4\mu\sqrt{a^2-r^2}}{R(1-\nu)\pi}. \quad (5.45.34)$$

To find the radius of contact in terms of the indenter load P , we use Eq. (5.45.16) to obtain

$$P = -2\pi \int_{t=0}^a t f(t) dt = \frac{8\mu}{R(1-\nu)} \int_{t=0}^a t^2 dt = \frac{8\mu a^3}{3R(1-\nu)}, \quad (5.45.35)$$

so that

$$a^3 = \frac{3(1-\nu)PR}{8\mu}. \quad (5.45.36)$$

To find the vertical displacement outside the contact region, we have, for $r \geq a$, [see Eq. (4.45.11)]

$$u_z = -\frac{2(1-\nu)}{2\mu} \int_{t=0}^a f(t) \sin^{-1}(t/r) dt = \frac{4}{R\pi} \int_{t=0}^a t \sin^{-1}(t/r) dt. \quad (5.45.37)$$

By letting $\sin \theta = t/r$, we can obtain

$$u_z = \frac{4}{R\pi} \left(\frac{r^2}{2} \right) \left[\theta \sin^2 \theta - \frac{\theta}{2} + \frac{\sin 2\theta}{2} \right]_0^{\sin^{-1}(a/r)} \quad \text{for } r \geq a. \quad (5.45.38)$$

In particular, at the separation point, $r = a$, we have

$$u_z = \frac{2a^2}{R\pi} \left(\frac{\pi}{2} - \frac{\pi}{4} \right) = \frac{2a^2 \pi}{R\pi 4} = \frac{a^2}{2R} \quad \text{at } r = a. \quad (5.45.39)$$

Now, from $u_z(r) = w_o - \frac{r^2}{2R}$, we obtain the total penetration to be

$$w_o = u_z(a) + \frac{a^2}{2R} = \frac{a^2}{2R} + \frac{a^2}{2R} = \frac{a^2}{R}. \quad (5.45.40)$$

In summary, in terms of the indenter load P and the radius of the rigid smooth sphere R , we have

$$\text{Radius of contact: } a = \left[\frac{3(1-\nu)PR}{8\mu} \right]^{1/3}. \quad (5.45.41)$$

$$\text{Contact normal stress: } T_{zz} = -\frac{4\mu\sqrt{a^2-r^2}}{R(1-\nu)\pi}. \quad (5.45.42)$$

APPENDIX 5A.1: SOLUTION OF THE INTEGRAL EQUATION IN SECTION 5.45

In this appendix we will verify that for a given function $w_o + w(r)$, the solution to the integral equation

$$w_o + w(r) = -\frac{(1-\nu)}{\mu} \left[\frac{\pi}{2} \int_0^a f(t) dt - \int_0^r f(t) \cos^{-1}(t/r) dt \right] \quad (i)$$

is

$$f(t) = B\delta(a - t) + \frac{\mu g(t)}{(1 - \nu)}, \tag{ii}$$

where

$$g(t) = \frac{2}{\pi t} \frac{d}{dt} \int_0^t \frac{dw}{dr} \frac{r^2 dr}{\sqrt{t^2 - r^2}}. \tag{iii}$$

To begin, we first note that $\int_0^t \delta(a - t) dt = 1$ and $\int_0^r \delta(a - t) dt = 0$. Thus, using Eq. (ii), the terms inside the bracket of Eq. (i) become

$$\left[\frac{\pi}{2} B + \frac{\pi}{2} \frac{\mu}{(1 - \nu)} \int_0^a g(t) dt \right] - \frac{\mu}{(1 - \nu)} \int_0^r g(t) \cos^{-1}(t/r) dt. \tag{iv}$$

Now, from Eq. (iii), we can show that

$$w(r) = \int_0^r g(t) \cos^{-1}(t/r) dt. \tag{v}$$

Indeed, from this equation, i.e., Eq. (v), we have

$$\begin{aligned} \frac{dw(r)}{dr} &= \int_0^r g(t) \frac{d}{dr} \left(\cos^{-1} \frac{t}{r} \right) dt + g(r) \cos^{-1} \left(\frac{r}{r} \right) = \int_0^r g(t) \frac{d}{dr} \left(\cos^{-1} \frac{t}{r} \right) dt \\ &= \int_0^r g(t) \frac{t}{r} \frac{1}{\sqrt{r^2 - t^2}} dt. \end{aligned} \tag{vi}$$

Thus,

$$\int_{r=0}^t \frac{dw}{dr} \frac{r^2 dr}{\sqrt{t^2 - r^2}} = \int_{r=0}^t \left[\int_0^r g(t) \frac{t}{r} \frac{1}{\sqrt{r^2 - t^2}} dt \right] \frac{r^2 dr}{\sqrt{t^2 - r^2}}. \tag{vii}$$

Interchanging the order of integration, we have (see Figure 5A.1)

$$\int_{r=0}^t \frac{dw}{dr} \frac{r^2 dr}{\sqrt{t^2 - r^2}} = \int_{t'=0}^{t'=t} t' g(t') \left[\int_{r=t'}^{r=t} \frac{r dr}{\sqrt{r^2 - t'^2} \sqrt{t^2 - r^2}} \right] dt'. \tag{viii}$$

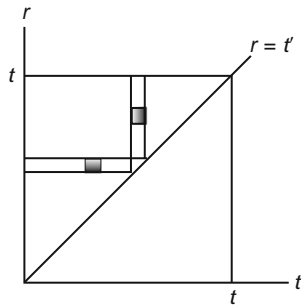

FIGURE 5A.1

Now,

$$\int_{r=t'}^{r=t} \frac{rdr}{\sqrt{r^2 - t'^2}\sqrt{t^2 - r^2}} = \frac{1}{2} \int_{x=t'^2}^{x=t^2} \frac{dx}{\sqrt{x - t'^2}\sqrt{t^2 - x}} = -\frac{1}{2} \left[\sin^{-1} \left(\frac{-2x + t'^2 + t^2}{t^2 - t'^2} \right) \right]_{x=t'^2}^{x=t^2} = \frac{\pi}{2}. \quad (\text{ix})$$

Therefore, from Eq. (viii), we have

$$\int_{r=0}^t \frac{dw}{dr} \frac{r^2 dr}{\sqrt{t^2 - r^2}} = \frac{\pi}{2} \int_0^t t' g(t') dt', \quad (\text{x})$$

so that

$$\frac{d}{dt} \int_{r=0}^t \frac{dw}{dr} \frac{r^2 dr}{\sqrt{t^2 - r^2}} = \frac{\pi}{2} [tg(t)] = \frac{\pi t}{2} g(t). \quad (\text{xi})$$

Thus,

$$g(t) = \frac{2}{\pi t} \frac{d}{dt} \int_0^t \frac{dw}{dr} \frac{r^2 dr}{\sqrt{t^2 - r^2}},$$

which is Eq. (iii).

We now return to the terms inside the bracket of Eq. (i) [i.e., Eq. (iv)]. In view of the equation $w(r) = \int_0^r g(t) \cos^{-1}(t/r) dt$, those terms become

$$\left[\frac{\pi}{2} B + \frac{\pi}{2} \frac{\mu}{(1-\nu)} \int_0^a g(t) dt \right] - \frac{\mu}{(1-\nu)} w(r), \quad (\text{xii})$$

so that Eq. (i) becomes

$$w_o + w(r) = -\frac{(1-\nu)\pi}{2\mu} B - \frac{\pi}{2} \int_0^a g(t) dt + w(r), \quad (\text{xiii})$$

from which we get

$$B = -\frac{2\mu}{(1-\nu)\pi} \left[w_o + \frac{\pi}{2} \int_0^a g(t) dt \right]. \quad (\text{xiv})$$

In other words, with B given by the preceding equation, the function

$$f(t) = B\delta(a-t) + \frac{\mu}{(1-\nu)} g(t) \quad \text{where} \quad g(t) = \frac{2}{\pi t} \frac{d}{dt} \int_0^t \frac{dw}{dr} \frac{r^2 dr}{\sqrt{t^2 - r^2}}$$

satisfies the integral equation

$$w_o + w(r) = -\frac{(1-\nu)}{\mu} \left[\frac{\pi}{2} \int_0^a f(t) dt - \int_0^r f(t) \left(\cos^{-1} \frac{t}{r} \right) dt \right].$$

We note that in certain applications, the constant B must be zero, in which case, w_o cannot be arbitrarily prescribed but must be given by the following equation [see Eq. (xiv)]:

$$w_o = -\frac{\pi}{2} \int_o^a g(t) dt. \quad (\text{xv})$$

For example, for a spherical indenter, we had $g(t) = -\frac{4}{R\pi} t$ [see Eq. (5.45.30) and Eq. (ii)]; thus,

$$w_o = -\frac{\pi}{2} \int_o^a g(t) dt = \frac{2}{R} \int_o^a t dt = \frac{a^2}{R}, \quad (\text{xvi})$$

which is Eq. (5.45.40).

PROBLEMS FOR CHAPTER 5, PART A, SECTIONS 5.1–5.8

- 5.1** Show that the null vector is the only isotropic vector. (*Hint*: Assume that \mathbf{a} is an isotropic vector and use a simple change of basis to equate the primed and the unprimed components.)
- 5.2** Show that the most general isotropic second-order tensor is of the form of $\alpha \mathbf{I}$, where α is a scalar and \mathbf{I} is the identity tensor.
- 5.3** For an isotropic linearly elastic body, (a) verify the $\mu = \mu(\lambda, E_Y)$ as given in Table 5.1 and (b) obtain the value of μ as $E_Y/\lambda \rightarrow 0$.
- 5.4** From $\lambda = \nu E_Y / [(1 + \nu)(1 - 2\nu)]$, $\lambda = 2\mu\nu / (1 - 2\nu)$, and $k = \lambda(1 + \nu) / 3\nu$, obtain $\mu = \mu(E_Y, \nu)$ and $k = k(\mu, \nu)$.
- 5.5** Show that for an incompressible material ($\nu \rightarrow 1/2$), that
(a) $\mu = E_Y/3$, $\lambda \rightarrow \infty$, $k \rightarrow \infty$, but $k - \lambda = (2/3)\mu$.
(b) $\mathbf{T} = 2\mu\mathbf{E} + (T_{kk}/3)\mathbf{I}$, where T_{kk} is constitutively indeterminate.
- 5.6** Given $A_{ijkl} = \delta_{ij}\delta_{kl}$ and $B_{ijkl} = \delta_{ik}\delta_{jl}$,
(a) Obtain A_{11jk} and B_{11jk} .
(b) Identify those A_{11jk} that are different from B_{11jk} .
- 5.7** Show that for an anisotropic linearly elastic material, the principal directions of stress and strain are in general not coincident.
- 5.8** The Lamé constants are $\lambda = 119.2 \text{ GPa}(17.3 \times 10^6 \text{ psi})$, $\mu = 79.2 \text{ GPa}(11.5 \times 10^6 \text{ psi})$. Find Young's modulus, Poisson's ratio, and the bulk modulus.
- 5.9** Given Young's modulus $E_Y = 103 \text{ GPa}$, Poisson's ratio $\nu = 0.34$. Find the Lamé constants λ and μ . Also find the bulk modulus.
- 5.10** Given Young's modulus $E_Y = 193 \text{ GPa}$, shear modulus $\mu = 76 \text{ GPa}$. Find Poisson's ratio ν , Lamé's constant λ , and the bulk modulus k .
- 5.11** If the components of strain at a point of structural steel are

$$\begin{aligned} E_{11} &= 36 \times 10^{-6}, & E_{22} &= 40 \times 10^{-6}, & E_{33} &= 25 \times 10^{-6}, \\ E_{12} &= 12 \times 10^{-6}, & E_{23} &= 0, & E_{13} &= 30 \times 10^{-6}. \end{aligned}$$

find the stress components.

$$\lambda = 119.2 \text{ GPa}(17.3 \times 10^6 \text{ psi}), \mu = 79.2 \text{ GPa}(11.5 \times 10^6 \text{ psi}).$$

5.12 Do the previous problem if the strain components are

$$E_{11} = 100 \times 10^{-6}, E_{22} = -200 \times 10^{-6}, E_{33} = 100 \times 10^{-6}, E_{12} = -100 \times 10^{-6}, E_{23} = 0, E_{13} = 0.$$

5.13 An isotropic elastic body ($E_Y = 207 \text{ GPa}$, $\mu = 79.2 \text{ GPa}$) has a uniform state of stress given by

$$[\mathbf{T}] = \begin{bmatrix} 100 & 40 & 60 \\ 40 & -200 & 0 \\ 60 & 0 & 200 \end{bmatrix} \text{MPa}.$$

(a) What are the strain components?

(b) What is the total change of volume for a five-centimeter cube of the material?

5.14 An isotropic elastic sphere ($E_Y = 207 \text{ GPa}$, $\mu = 79.2 \text{ GPa}$) of 5 cm radius is under the uniform stress

$$\text{field: } [\mathbf{T}] = \begin{bmatrix} 6 & 2 & 0 \\ 2 & -3 & 0 \\ 0 & 0 & 0 \end{bmatrix} \text{MPa. Find the change of volume for the sphere.}$$

5.15 Given a motion $x_1 = X_1 + k(X_1 + X_2)$, $x_2 = X_2 + k(X_1 - X_2)$, show that for a function $f(a, b) = ab$,

$$(a) f(x_1, x_2) = f(X_1, X_2) + O(k), \quad \frac{\partial f(x_1, x_2)}{\partial x_1} = \frac{\partial f(X_1, X_2)}{\partial X_1} + O(k), \quad \text{where } O(k) \rightarrow 0 \text{ as } k \rightarrow 0.$$

5.16 Do the previous problem for $f(a, b) = a^2 + b^2$.

5.17 Given the following displacement field in an isotropic linearly elastic solid:

$$u_1 = kX_3X_2, \quad u_2 = kX_3X_1, \quad u_3 = k(X_1^2 - X_2^2), \quad k = 10^{-4}.$$

(a) Find the stress components, and (b) in the absence of body forces, is the state of stress a possible equilibrium stress field?

5.18 Given the following displacement field in an isotropic linearly elastic solid:

$$u_1 = kX_2X_3, \quad u_2 = kX_1X_3, \quad u_3 = kX_1X_2, \quad k = 10^{-4}.$$

(a) Find the stress components, and (b) in the absence of body forces, is the state of stress a possible equilibrium stress field?

5.19 Given the following displacement field in an isotropic linearly elastic solid:

$$u_1 = kX_2X_3, \quad u_2 = kX_1X_3, \quad u_3 = k(X_1X_2 + X_3^2), \quad k = 10^{-4}$$

(a) Find the stress components, and (b) in the absence of body forces, is the state of stress a possible equilibrium stress field?

PROBLEMS FOR CHAPTER 5, PART A, SECTIONS 5.9–5.12 (A.1)

5.20 Show that for any function $f(s)$, the displacement $u_1 = f(s)$ where $s = x_1 \pm c_L t$ satisfies the wave equation $\partial^2 u_1 / \partial t^2 = c_L^2 (\partial^2 u_1 / \partial x_1^2)$.

5.21 Calculate the ratio of the phase velocities c_L / c_T for the following Poisson's ratios: 1/3, 0.49, and 0.499.

5.22 Assume a displacement field that depends only on x_2 and t , i.e., $u_i = u_i(x_2, t)$. Obtain the differential equations that $u_i(x_2, t)$ must satisfy to be a possible motion in the absence of body forces.

5.23 Consider a linearly elastic medium. Assume the following form for the displacement field:

$$u_1 = \varepsilon[\sin \beta(x_3 - ct) + \alpha \sin \beta(x_3 + ct)], \quad u_2 = u_3 = 0.$$

- (a) What is the nature of this elastic wave (longitudinal, transverse, direction of propagation)?
 (b) Find the strains and stresses, and determine under what condition(s) the equations of motion are satisfied in the absence of body forces.
 (c) Suppose that there is a boundary at $x_3 = 0$ that is traction free. Under what condition(s) will the above motion satisfy this boundary condition for all time?
 (d) Suppose that there is a boundary at $x_3 = \ell$ that is also traction free. What further conditions will be imposed on the above motion to satisfy this boundary condition for all time?
- 5.24** Do the previous problem (Prob. 5.23) if the boundary $x_3 = 0$ is fixed (no motion) and $x_3 = \ell$ is traction free.

5.25 Do Prob. 5.23 if the boundaries $x_3 = 0$ and $x_3 = \ell$ are both rigidly fixed (no motion).

5.26 Do Prob. 5.23 if the assumed displacement field is of the form:

$$u_3 = \varepsilon[\sin \beta(x_3 - ct) + \alpha \sin \beta(x_3 + ct)], \quad u_1 = u_2 = 0.$$

5.27 Do the previous problem, Prob. 5.26, if the boundary $x_3 = 0$ is fixed (no motion) and $x_3 = \ell$ is traction free ($\mathbf{t} = \mathbf{0}$).

5.28 Do Prob. 5.26 if the boundaries $x_3 = 0$ and $x_3 = \ell$ are both rigidly fixed.

5.29 Consider the displacement field: $u_i = u_i(x_1, x_2, x_3, t)$. In the absence of body forces,

- (a) obtain the governing equation for u_i for the case where the motion is equivoluminal.
 (b) obtain the governing equation for the dilatation e for the case where the motion is irrotational:
 $\partial u_i / \partial x_j = \partial u_j / \partial x_i$.

5.30 (a) Write a displacement field for an infinite train of longitudinal waves propagating in the direction of $3\mathbf{e}_1 + 4\mathbf{e}_2$. (b) Write a displacement field for an infinite train of transverse waves propagating in the direction of $3\mathbf{e}_1 + 4\mathbf{e}_2$ and polarized in the x_1x_2 plane.

5.31 Solve for ε_2 and ε_3 in terms of ε_1 from the following two algebra equations:

$$\varepsilon_2(\cos 2\alpha_1) + \varepsilon_3 n(\sin 2\alpha_3) = \varepsilon_1 \cos 2\alpha_1 \quad (\text{i})$$

$$\varepsilon_2 \sin 2\alpha_1 - (\varepsilon_3/n)(\cos 2\alpha_1) = -\varepsilon_1 \sin 2\alpha_1 \quad (\text{ii})$$

5.32 A transverse elastic wave of amplitude ε_1 incidents on a traction-free plane boundary. If the Poisson's ratio $\nu = 1/3$, determine the amplitudes and angles of reflection of the reflected waves for the following two incident angles: (a) $\alpha_1 = 0$ and (b) $\alpha_1 = 15^\circ$.

5.33 Referring to Figure 5.11.1, consider a transverse elastic wave incident on a traction-free plane surface ($x_2 = 0$) with an angle of incident α_1 with the x_2 -axis and polarized normal to x_1x_2 , the plane of incidence. Show that the boundary condition at $x_2 = 0$ can be satisfied with only a reflected transverse wave that is similarly polarized. What is the relation of the amplitudes, wavelengths, and direction of propagation of the incident and reflected wave?

5.34 Do the problem of Section 5.11 (Reflection of Plane Elastic Waves, Figure 5.11-1) for the case where the boundary $x_2 = 0$ is fixed.

- 5.35 A longitudinal elastic wave is incident on a fixed boundary $x_2 = 0$ with an incident angle of α_1 with the x_2 axis (similar to Figure 5.11-1). Show that in general there are two reflected waves, one longitudinal and the other transverse (also polarized in the incident plane x_1x_2). Also, find the amplitude ratio of reflected to incident elastic waves.
- 5.36 Do the previous problem (Prob. 5.35) for the case where $x_2 = 0$ is a traction-free boundary.
- 5.37 Verify that the thickness stretch vibration given by Eq. (5.12.3), i.e., $u_1 = (A \cos kx_1 + B \sin kx_1)(C \cos c_L kt + D \sin c_L kt)$, does satisfy the longitudinal wave equation $\partial^2 u_1 / \partial t^2 = c_L^2 (\partial^2 u_1 / \partial x_1^2)$.
- 5.38 (a) Find the thickness-stretch vibration of a plate, where the left face ($x_1 = 0$) is subjected to a forced displacement $\mathbf{u} = (\alpha \cos \omega t) \mathbf{e}_1$ and the right face $x_1 = \ell$ is free to move. (b) Determine the values of ω that give resonance.
- 5.39 (a) Find the thickness stretch vibration if the $x_1 = 0$ face is being forced by a traction $\mathbf{t} = (\beta \cos \omega t) \mathbf{e}_1$ and the right-hand face $x_1 = \ell$ is fixed. (b) Find the resonance frequencies.
- 5.40 (a) Find the thickness-shear vibration if the left-hand face $x_1 = 0$ has a forced displacement $\mathbf{u} = (\alpha \cos \omega t) \mathbf{e}_3$ and the right-hand face $x_1 = \ell$ is fixed. (b) Find the resonance frequencies.
- 5.41 (a) Find the thickness-shear vibration if the left-hand face $x_1 = 0$ has a forced displacement $\mathbf{u} = \alpha(\cos \omega t \mathbf{e}_2 + \sin \omega t \mathbf{e}_3)$ and the right-hand face $x_1 = \ell$ is fixed, and (b) find the resonance frequencies.

PROBLEMS FOR CHAPTER 5, PART A, SECTIONS 5.13–5.19 (A.2)

- 5.42 A cast-iron bar, 200 cm long and 4 cm in diameter, is pulled by equal and opposite axial force P at its ends. (a) Find the maximum normal and shearing stresses if $P = 90,000 \text{ N}$. (b) Find the total elongation and lateral contraction ($E_Y = 103 \text{ GPa}$, $\nu = 0.3$).
- 5.43 A composite bar, formed by welding two slender bars of equal length and equal cross-sectional area, is loaded by an axial load P as shown in Figure P5.1. If Young's moduli of the two portions are $E_Y^{(1)}$ and $E_Y^{(2)}$, find how the applied force is distributed between the two halves.

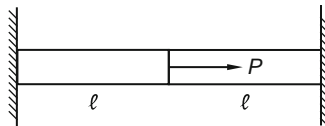

FIGURE P5.1

- 5.44 A bar of cross-sectional area A is stretched by a tensile force P at each end. (a) Determine the normal and shearing stresses on a plane with a normal vector that makes an angle α with the axis of the bar. (b) For what value of α are the normal and shearing stresses equal? (c) If the load carrying capacity of the bar is based on the shearing stress on the plane defined by $\alpha = \alpha_o$ to be less than τ_o , what is the maximum allowable load P ?

- 5.45** A cylindrical bar that has its lateral surface constrained so that there can be no lateral expansion is then loaded with an axial compressive stress $T_{11} = -\sigma$. (a) Find T_{22} and T_{33} in terms of σ and the Poisson's ratio ν , and (b) show that the effective Young's modulus $(E_Y)_{eff} \equiv T_{11}/E_{11}$ is given by $(E_Y)_{eff} = (1 - \nu)/(1 - 2\nu - 2\nu^2)$.
- 5.46** Let the state of stress in a tension specimen be $T_{11} = \sigma$, with all other $T_{ij} = 0$. (a) Find the components of the deviatoric stress defined by $\mathbf{T}^o = \mathbf{T} - (1/3)\mathbf{T}_{kk}\mathbf{I}$. (b) Find the principal scalar invariants of \mathbf{T}^o .
- 5.47** A circular cylindrical bar of length ℓ hangs vertically under gravity force from the ceiling. Let the x_1 axis coincide with the axis of the bar and point downward, and let the point $(x_1, x_2, x_3) = (0, 0, 0)$ be fixed at the ceiling. (a) Verify that the following stress field satisfies the equations of equilibrium in the presence of the gravity force: $T_{11} = \rho g(\ell - x_1)$, all other $T_{ij} = 0$, and (b) verify that the boundary conditions of zero surface traction on the lateral surface and the lower end face are satisfied, and (c) obtain the resultant force of the surface traction at the upper end face.
- 5.48** A circular steel shaft is subjected to twisting couples of 2700 Nm . The allowable tensile stress is 0.124 GPa . If the allowable shearing stress is 0.6 times the allowable tensile stress, what is the minimum allowable diameter?
- 5.49** In Figure P5.2, a twisting torque M_t is applied to the rigid disc A . Find the twisting moments transmitted to the circular shafts on either side of the disc.

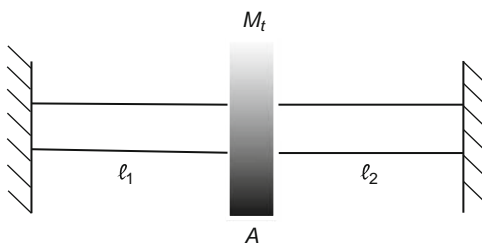

FIGURE P5.2

- 5.50** What needs to be changed in the solution for torsion of a solid circular bar, obtained in Section 5.14, to be valid for torsion of a hollow circular bar with inner radius a and outer radius b ?
- 5.51** A circular bar of radius r_o is under the action of axial tensile load P and twisting couples of magnitude M_t . (a) Determine the stress throughout the bar. (b) Find the maximum normal and shearing stress.
- 5.52** Compare the twisting torque that can be transmitted by a shaft with an elliptical cross-section having a major diameter equal to twice the minor diameter with a shaft of circular cross-section having a diameter equal to the major diameter of the elliptical shaft. Both shafts are of the same material. Also compare the unit twist (i.e., twist angle per unit length) under the same twisting moment. Assume that the maximum twisting moment that can be transmitted is controlled by the maximum shearing stress.
- 5.53** Repeat the previous problem except that the circular shaft has a diameter equal to the minor diameter of the elliptical shaft.

- 5.54** Consider torsion of a cylindrical bar with an equilateral triangular cross-section as shown in Figure P5.3. (a) Show that a warping function $\varphi = C(3x_2^2 x_3 - x_3^3)$ generates an equilibrium stress field. (b) Determine the constant C so as to satisfy the traction-free boundary condition on the lateral surface $x_2 = a$. With C so obtained, verify that the other two lateral surfaces are also traction free. (c) Evaluate the shear stress at the corners and along the line $x_3 = 0$. (d) Along the line $x_3 = 0$, where does the greatest shear stress occur?

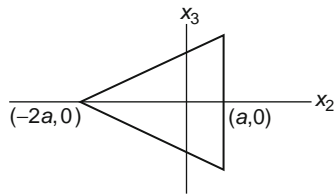

FIGURE P5.3

- 5.55** Show from the compatibility equations that the Prandtl stress function $\psi(x_2, x_3)$ for torsion problem must satisfy the equation $\frac{\partial^2 \psi}{\partial x_3^2} + \frac{\partial^2 \psi}{\partial x_2^2} = \text{constant}$.

- 5.56** Given that the Prandtl stress function for a rectangular bar in torsion is given by

$$\psi = \left(\frac{32\mu\alpha'a^2}{\pi^3} \right) \sum_{n=1,3,5}^{\infty} \frac{1}{n^3} (-1)^{(n-1)/2} \left\{ 1 - \frac{\cosh(n\pi x_3/2a)}{\cosh(n\pi b/2a)} \right\} \cos \frac{n\pi x_2}{2a}$$

The cross-section is defined by $-a \leq x_2 \leq a$ and $-b \leq x_3 \leq b$. Assume $b > a$, (a) find the maximum shearing stress, and (b) find the maximum normal stress and the plane on which it acts. To derive Eq. (5.18.11) for the maximum shearing stress, use $\sum_{1,3,5}^{\infty} \frac{1}{n^2} = \frac{\pi^2}{8}$.

- 5.57** Obtain the relationship between the twisting moment M_t and the twist angle per unit length α' for a rectangular bar under torsion. *Note:* $1 + \frac{1}{3^4} + \frac{1}{5^4} + \dots = \frac{\pi^4}{96}$.

- 5.58** In pure bending of a bar, let $\mathbf{M}_L = M_2\mathbf{e}_2 + M_3\mathbf{e}_3 = -\mathbf{M}_R$, where \mathbf{e}_2 and \mathbf{e}_3 are not along the principal axes, show that the flexural stress T_{11} is given by

$$T_{11} = -\frac{M_2 I_{23} + M_3 I_{22}}{(I_{33} I_{22} - I_{23}^2)} x_2 + \frac{M_2 I_{33} + M_3 I_{23}}{(I_{33} I_{22} - I_{23}^2)} x_3.$$

- 5.59** From the strain components for pure bending, $E_{11} = \frac{M_2 x_3}{I_{22} E_Y}$, $E_{22} = E_{33} = -\frac{\nu M_2 x_3}{I_{22} E_Y}$, $E_{12} = E_{13} = E_{23} = 0$, obtain the displacement field.

- 5.60** In pure bending of a bar, let $\mathbf{M}_L = M_2\mathbf{e}_2 + M_3\mathbf{e}_3 = -\mathbf{M}_R$, where \mathbf{e}_2 and \mathbf{e}_3 are along the principal axes; show that the neutral axis (that is, the axis on the cross-section where the flexural stress T_{11} is zero) is, in general, not parallel to the couple vectors.

PROBLEMS FOR CHAPTER 5, PART A, SECTIONS 5.20–5.37 (A.3)

- 5.61** For the plane strain problem, derive the biharmonic equation for the Airy stress function.
- 5.62** For the plane stress problem, derive the biharmonic equation for the Airy stress function.
- 5.63** Consider the Airy stress function $\varphi = \alpha_1 x_1^2 + \alpha_2 x_1 x_2 + \alpha_3 x_2^2$. (a) Verify that it satisfies the biharmonic equation. (b) Determine the in-plane stresses T_{11} , T_{12} and T_{22} . (c) Determine and sketch the tractions on the four rectangular boundaries $x_1 = 0$, $x_1 = b$, $x_2 = 0$, $x_2 = c$. (d) As a plane strain solution, determine T_{13} , T_{23} , T_{33} and all the strain components. (e) As a plane stress solution, determine T_{13} , T_{23} , T_{33} and all the strain components.
- 5.64** Consider the Airy stress function $\varphi = \alpha x_1^2 x_2$. (a) Verify that it satisfies the biharmonic equation. (b) Determine the in-plane stresses T_{11} , T_{12} and T_{22} . (c) Determine and sketch the tractions on the four rectangular boundaries $x_1 = 0$, $x_1 = b$, $x_2 = 0$, $x_2 = c$. (d) As a plane strain solution, determine T_{13} , T_{23} , T_{33} and all the strain components. (e) As a plane stress solution, determine T_{13} , T_{23} , T_{33} and all the strain components.
- 5.65** Consider the Airy stress function $\varphi = \alpha(x_1^4 - x_2^4)$. (a) Verify that it satisfies the biharmonic equation. (b) Determine the in-plane stresses T_{11} , T_{12} and T_{22} . (c) Determine and sketch the tractions on the four rectangular boundaries $x_1 = 0$, $x_1 = b$, $x_2 = 0$, $x_2 = c$. (d) As a plane strain solution, determine T_{13} , T_{23} , T_{33} and all the strain components. (e) As a plane stress solution, determine T_{13} , T_{23} , T_{33} and all the strain components.
- 5.66** Consider the Airy stress function $\varphi = \alpha x_1 x_2^2 + x_1 x_2^3$. (a) Verify that it satisfies the biharmonic equation. (b) Determine the in-plane stresses T_{11} , T_{12} and T_{22} . (c) Determine the condition necessary for the traction at $x_2 = c$ to vanish, and (d) determine the tractions on the remaining boundaries $x_1 = 0$, $x_1 = b$ and $x_2 = 0$.

- 5.67** Obtain the in-plane displacement components for the plane stress solution for the cantilever beam from the following strain-displacement relations:

$$E_{11} = \frac{\partial u_1}{\partial x_1} = \frac{P x_1 x_2}{E_Y I}, \quad E_{22} = \frac{\partial u_2}{\partial x_2} = -\frac{v P x_1 x_2}{E_Y I}, \quad E_{12} = \left(\frac{P}{4 \mu I}\right) \left(\frac{h^2}{4} - x_2^2\right).$$

- 5.68** (a) Let the Airy stress function be of the form $\varphi = f(x_2) \cos \frac{m \pi x_1}{\ell}$. Show that the most general form of $f(x_2)$ is:

$$f(x_2) = C_1 \cosh \lambda_m x_2 + C_2 \sinh \lambda_m x_2 + C_3 x_2 \cosh \lambda_m x_2 + C_4 x_2 \sinh \lambda_m x_2.$$

- (b) Is the answer the same if $\varphi = f(x_2) \sin \frac{m \pi x_1}{\ell}$?
- 5.69** Consider a rectangular bar defined by $-\ell \leq x_1 \leq \ell$, $-c \leq x_2 \leq c$, $-b \leq x_3 \leq b$, where b/ℓ is very small. At the boundaries $x_2 = \pm c$, the bar is acted on by equal and opposite cosine normal stress $A_m \cos \lambda_m x_1$, where $\lambda_m = m\pi/\ell$ (per unit length in x_3 direction). (a) Obtain the in-plane stresses inside the bar. (b) Find the surface tractions at $x_1 = \pm \ell$. Under what conditions can these surface tractions be removed without affecting T_{22} and T_{12} (except near $x_1 = \pm \ell$)? How would T_{11} be affected by the removal. *Hint:* Assume $\varphi = f(x_2) \cos \lambda_m x_1$, where $\lambda_m = m\pi/\ell$ and use the results of the previous problem.

5.70 Verify that the equations of equilibrium in polar coordinates are satisfied by

$$T_{rr} = \frac{1}{r} \frac{\partial \varphi}{\partial r} + \frac{1}{r^2} \frac{\partial^2 \varphi}{\partial \theta^2}, \quad T_{\theta\theta} = \frac{\partial^2 \varphi}{\partial r^2}, \quad T_{r\theta} = -\frac{\partial}{\partial r} \left(\frac{1}{r} \frac{\partial \varphi}{\partial \theta} \right).$$

5.71 Obtain $T_{rr} = \frac{1}{r} \frac{\partial \varphi}{\partial r} + \left(\frac{1}{r^2} \right) \frac{\partial^2 \varphi}{\partial \theta^2}$ from the transformation law

$$\begin{bmatrix} T_{rr} & T_{r\theta} \\ T_{\theta r} & T_{\theta\theta} \end{bmatrix} = \begin{bmatrix} \cos \theta & \sin \theta \\ -\sin \theta & \cos \theta \end{bmatrix} \begin{bmatrix} T_{11} & T_{12} \\ T_{21} & T_{22} \end{bmatrix} \begin{bmatrix} \cos \theta & -\sin \theta \\ \sin \theta & \cos \theta \end{bmatrix}$$

$$\text{and } T_{11} = \frac{\partial^2 \varphi}{\partial x_1^2}, T_{22} = \frac{\partial^2 \varphi}{\partial x_2^2} \text{ and } T_{12} = -\frac{\partial^2 \varphi}{\partial x_1 \partial x_2}.$$

5.72 Obtain the displacement field for the plane strain solution of the axisymmetric stress distribution from that for the plane stress solution obtained in Section 5.28.

5.73 Let the Airy stress function be $\varphi = f(r) \sin n\theta$; find the differential equation for $f(r)$. Is this the same ODE for $f(r)$ if $\varphi = f(r) \cos n\theta$?

5.74 Obtain the four independent solutions for the following equation:

$$\left(\frac{d^2}{dr^2} + \frac{1}{r} \frac{d}{dr} - \frac{n^2}{r} \right) \left(\frac{d^2 f}{dr^2} + \frac{1}{r} \frac{df}{dr} - \frac{n^2}{r} f \right) = 0.$$

5.75 Evaluate

$$\left[\frac{d}{dn} (r^n \cos n\theta) \right]_{n=0}, \left[\frac{d}{dn} (r^n \sin n\theta) \right]_{n=0}$$

$$\left[\frac{d}{dn} (r^{-n+2} \cos n\theta) \right]_{n=1} \text{ and } \left[\frac{d}{dn} (r^n \cos n\theta) \right]_{n=1}.$$

5.76 In the Flamont problem (Section 5.37), if the concentrated line load F , acting at the origin on the surface of a 2-D half-space (defined by $-\pi/2 \leq \theta \leq \pi/2$), is tangent to the surface ($\theta = \pi/2$), show that

$$T_{rr} = -\left(\frac{2F}{\pi} \right) \frac{\sin \theta}{r}, \quad T_{\theta\theta} = T_{r\theta} = 0.$$

5.77 Verify that the displacement field for the Flamont problem under a normal force P is given by

$$u_r = -\frac{P}{\pi E_Y} \{(1-\nu)\theta \sin \theta + 2 \ln r \cos \theta\}, \quad u_\theta = \frac{P}{\pi E_Y} \{(1+\nu) \sin \theta + 2 \ln r \sin \theta - (1-\nu)\theta \cos \theta\},$$

The 2-D half-space is defined by $-\pi/2 \leq \theta \leq \pi/2$.

PROBLEMS FOR CHAPTER 5, PART A, SECTIONS 5.38–5.46 (A.4)

5.78 Show that Eq. (5.38.6), i.e., $\mathbf{u} = \Psi - \{1/[4(1-\nu)]\} \nabla(\mathbf{x} \cdot \Psi + \Phi)$ can also be written as: $2\mu \mathbf{u} = -4(1-\nu) \boldsymbol{\psi} + \nabla(\mathbf{x} \cdot \boldsymbol{\psi} + \phi)$ where $\Psi = -2(1-\nu) \boldsymbol{\psi}/\mu$, $\Phi = -2(1-\nu) \phi/\mu$.

5.79 Show that with $u_i = \Psi_i - \frac{1}{4(1-\nu)} \frac{\partial}{\partial x_i} (x_n \Psi_n + \Phi)$, the Navier equations become

$$-\frac{\mu}{2(1-2\nu)} \left(x_n \frac{\partial \nabla^2 \Psi_n}{\partial x_i} - (1-4\nu) \nabla^2 \Psi_i + \frac{\partial \nabla^2 \Phi}{\partial x_i} \right) + B_i = 0.$$

5.80 Consider the potential functions given in Eq. (5.38.32) (see Example 5.38.5), i.e.,

$$\boldsymbol{\psi} = \psi(R) \mathbf{e}_R, \quad \phi = \phi(R), \quad \text{where} \quad \nabla^2 \phi = \frac{d^2 \phi}{dR^2} + \frac{2}{R} \frac{d\phi}{dR} = 0 \quad \text{and} \quad \nabla^2 \psi = \left(\frac{d^2 \psi}{dR^2} + \frac{2}{R} \frac{d\psi}{dR} - \frac{2\psi}{R^2} \right) \mathbf{e}_R = 0.$$

Show that these functions generate the following displacements, dilatation and stresses as given in Eqs. (5.38.35) to (5.38.38):

(a) Displacements: $2\mu u_R = R d\psi/dR + (-3 + 4\nu)\psi + d\phi/dR, \quad u_\theta = u_\beta = 0.$

(b) Dilatation: $e = -[(1-2\nu)/\mu][d\psi/dR + 2\psi/R].$

(c) Stresses: $T_{RR} = (2\nu - 4)d\psi/dR + (2 - 4\nu)\psi/R + d^2\phi/dR^2.$

$$T_{\beta\beta} = T_{\theta\theta} = -\{(2\nu - 1)d\psi/dR + 3\psi/R - (1/R)d\phi/dR\}.$$

5.81 Consider the potential functions given in Eq. (5.38.39) (see Example 5.38.6), i.e.,

$$\boldsymbol{\psi} = \mathbf{0}, \quad \phi = \phi(r, z) = \hat{\phi}(R, \beta), \quad \nabla^2 \phi = \nabla^2 \hat{\phi} = 0, \quad \text{where} \quad (r, \theta, z) \text{ and } (R, \theta, \beta)$$

are cylindrical and spherical coordinates, respectively, with z as the axis of symmetry, θ the longitudinal angle, and β the angle between z -axis and \mathbf{e}_R . Show that these functions generate the following displacements, dilatation, and stresses as given in Eqs. (5.38.40) to (5.38.45):

In cylindrical coordinates:

(a) Displacements: $2\mu u_r = \partial\phi/\partial r, u_\theta = 0, 2\mu u_z = \partial\phi/\partial z.$

(b) Dilatation: $e = 0.$

(c) $T_{rr} = \partial^2\phi/\partial r^2, T_{\theta\theta} = (1/r)\partial\phi/\partial r, T_{zz} = \partial^2\phi/\partial z^2, E_{r\theta} = E_{\theta z} = 0, T_{rz} = \partial^2\phi/\partial r\partial z.$

In spherical coordinates:

(d) Displacements: $2\mu u_R = \partial\hat{\phi}/\partial R, u_\theta = 0, 2\mu u_\beta = (1/R)\partial\hat{\phi}/\partial\beta.$

(e) Dilatation: $e = 0.$

(f) Stresses:

$$T_{RR} = \partial^2\hat{\phi}/\partial R^2, \quad T_{\beta\beta} = (1/R^2)\partial^2\hat{\phi}/\partial\beta^2 + (1/R)\partial\hat{\phi}/\partial R,$$

$$T_{R\theta} = T_{\theta\beta} = 0, \quad T_{\theta\theta} = (1/R)\partial\hat{\phi}/\partial R + (\cot\beta/R^2)\partial\hat{\phi}/\partial\beta,$$

$$T_{R\beta} = (1/R)\partial^2\hat{\phi}/\partial\beta\partial R - (1/R^2)\partial\hat{\phi}/\partial\beta.$$

5.82 For the potential functions given in Eq. (5.38.46) (see Example 5.38.7), i.e.,

$$\boldsymbol{\psi} = \psi(R, \beta) \mathbf{e}_z, \quad \phi = 0,$$

where $\nabla^2 \psi = 0$, show that these functions generate the following displacements u_i , dilatation e , and the stresses T_{ij} (in spherical coordinates) as given in Eqs. (5.38.47) to (5.38.50):

(a) Displacements:

$$2\mu u_R = -\{(3 - 4\nu)\psi - R\partial\psi/\partial R\} \cos\beta, \quad 2\mu u_\beta = \{(3 - 4\nu)\psi \sin\beta + \cos\beta\partial\psi/\partial\beta\}, \quad u_\theta = 0.$$

(b) Dilatation:

$$2\mu e = -(2 - 4\nu)[\cos\beta\partial\psi/\partial R - (\sin\beta/R)\partial\psi/\partial\beta].$$

(c) Stresses:

$$\begin{aligned}
 T_{RR} &= -[2(1-\nu)\cos\beta\partial\psi/\partial R - R\cos\beta\partial^2\psi/\partial R^2 - (2\nu\sin\beta/R)\partial\psi/\partial\beta], \\
 T_{\beta\beta} &= -[(2\nu-1)\cos\beta\partial\psi/\partial R - (2-2\nu)(\sin\beta/R)\partial\psi/\partial\beta - (\cos\beta/R)\partial^2\psi/\partial\beta^2], \\
 T_{\theta\theta} &= -\{(2\nu-1)\cos\beta\partial\psi/\partial R - [(2\nu-1)\sin\beta + 1/\sin\beta]\partial\psi/R\partial\beta\} \\
 T_{R\beta} &= -[2(1-\nu)\cos\beta\partial\psi/R\partial\beta - \cos\beta\partial^2\psi/\partial\beta\partial R - \sin\beta(1-2\nu)\partial\psi/\partial R] \\
 T_{R\theta} &= T_{\theta\beta} = 0.
 \end{aligned}$$

5.83 Show that $(1/R)$ is a harmonic function (i.e., it satisfies the Laplace equation $\nabla^2(1/R) = 0$), where R is the radial distance from the origin.

5.84 In Kelvin's problem, we used the potential function $\psi = \psi\mathbf{e}_z$, where in cylindrical coordinates, $\psi = A/R$, $R^2 = r^2 + z^2$. Using the results in Example 5.38.6, obtain the stresses.

5.85 Show that for $\varphi = C \ln(R+z)$, where $R^2 = r^2 + z^2$,

$$\partial^2\varphi/\partial r^2 = C\{z/R^3 - 1/[R(R+z)]\}.$$

5.86 Given the following potential functions:

$$\psi = (\partial\varphi/\partial z)\mathbf{e}_z, \quad \phi = (1-2\nu)\varphi \quad \text{where} \quad \varphi = C \ln(R+z), \quad R^2 = r^2 + z^2.$$

From the results of Example 3.38.4 and Eqs. (i), (ii), and (iii) of Section 5.40, obtain

$$\begin{aligned}
 T_{rr} &= C\{(3r^2z/R^5) - (1-2\nu)/[R(R+z)]\}, \\
 T_{\theta\theta} &= C(1-2\nu)\{-z/R^3 + 1/[R(R+z)]\}, \\
 T_{zz} &= 3Cz^3/R^5, \quad T_{rz} = 3Crz^2/R^5.
 \end{aligned}$$

5.87 The stresses in the Boussinesq problem in cylindrical coordinates are given by

$$\begin{aligned}
 T_{rr} &= -\frac{F_z}{2\pi} \left\{ \frac{3r^2z}{R^5} - \frac{(1-2\nu)}{R(R+z)} \right\}, \quad T_{\theta\theta} = -\frac{F_z(1-2\nu)}{2\pi} \left\{ -\frac{z}{R^3} + \frac{1}{R(R+z)} \right\}, \\
 T_{zz} &= -\frac{F_z}{2\pi} \frac{3z^3}{R^5}, \quad T_{rz} = -\frac{F_z}{2\pi} \frac{3rz^2}{R^5}, \quad T_{r\theta} = T_{\theta z} = 0.
 \end{aligned}$$

Obtain the stresses in rectangular Cartesian coordinates.

5.88 Obtain the variation of T_{zz} along the z -axis for the case where the normal load on the surface is uniform with intensity q_0 , and the loaded area is a circle of radius r_0 with its center at the origin.

5.89 For the potential function $\psi = D_1R^{-2}\cos\beta\mathbf{e}_z$, where (R, β, θ) are the spherical coordinates with β as the angle between \mathbf{e}_z and \mathbf{e}_R , obtain the following stresses.

$$\tilde{T}_{RR} = 2(5-\nu)D_1R^{-3}\cos^2\beta - 2D_1\nu R^{-3}, \quad \tilde{T}_{\beta R} = 2D_1R^{-3}(1+\nu)\cos\beta\sin\beta.$$

5.90 For the potential function

$$\tilde{\phi} = \tilde{\phi}(R, \beta) = C_1[R^{-3}(3 \cos^2 \beta - 1)/2] + C_2 R^{-1},$$

where (R, β, θ) are the spherical coordinates with β as the azimuthal angle, obtain the following stresses:

$$\tilde{T}_{RR} = 6C_1 R^{-5}(3 \cos^2 \beta - 1) + 2C_2 R^{-3}, \quad \tilde{T}_{\beta R} = 12C_1 R^{-5} \cos \beta \sin \beta.$$

PART B: ANISOTROPIC LINEARLY ELASTIC SOLID

5.46 CONSTITUTIVE EQUATIONS FOR AN ANISOTROPIC LINEARLY ELASTIC SOLID

In Section 5.2, we concluded that due to the symmetry of the strain and the stress tensors E_{ij} and T_{ij} , respectively, and the assumption that there exists a strain energy function U given by $T = (1/2)C_{ijkl}E_{ij}E_{kl}$, the most general anisotropic linearly elastic solid requires 21 elastic constants for its description. We can write the stress-strain relation for this general case in the following matrix notation (where $C_{ijkl} = C_{ijlk}$, $C_{ijkl} = C_{jikl}$, $C_{ijkl} = C_{klij}$):

$$\begin{bmatrix} T_{11} \\ T_{22} \\ T_{33} \\ T_{23} \\ T_{31} \\ T_{12} \end{bmatrix} = \begin{bmatrix} C_{1111} & C_{1122} & C_{1133} & C_{1123} & C_{1113} & C_{1112} \\ C_{1122} & C_{2222} & C_{2233} & C_{2223} & C_{1322} & C_{1222} \\ C_{1133} & C_{2233} & C_{3333} & C_{2333} & C_{1333} & C_{1233} \\ C_{1123} & C_{2223} & C_{2333} & C_{2323} & C_{1323} & C_{1223} \\ C_{1113} & C_{1322} & C_{1333} & C_{1323} & C_{1313} & C_{1213} \\ C_{1112} & C_{1222} & C_{1233} & C_{1223} & C_{1213} & C_{1212} \end{bmatrix} \begin{bmatrix} E_{11} \\ E_{22} \\ E_{33} \\ 2E_{23} \\ 2E_{31} \\ 2E_{12} \end{bmatrix}. \quad (5.46.1)$$

The indices in Eq. (5.46.1) are quite cumbersome, but they emphasize the tensorial character of the tensors \mathbf{T} , \mathbf{E} and \mathbf{C} . Eq. (5.46.1) is often written in the following “contracted form,” in which the indices are simplified, or “contracted.”

$$\begin{bmatrix} T_1 \\ T_2 \\ T_3 \\ T_4 \\ T_5 \\ T_6 \end{bmatrix} = \begin{bmatrix} C_{11} & C_{12} & C_{13} & C_{14} & C_{15} & C_{16} \\ C_{12} & C_{22} & C_{23} & C_{24} & C_{25} & C_{26} \\ C_{13} & C_{23} & C_{33} & C_{34} & C_{35} & C_{36} \\ C_{14} & C_{24} & C_{34} & C_{44} & C_{45} & C_{46} \\ C_{15} & C_{25} & C_{35} & C_{45} & C_{55} & C_{56} \\ C_{16} & C_{26} & C_{36} & C_{46} & C_{56} & C_{66} \end{bmatrix} \begin{bmatrix} E_1 \\ E_2 \\ E_3 \\ E_4 \\ E_5 \\ E_6 \end{bmatrix}. \quad (5.46.2)$$

We note that Eq. (5.46.2) can also be written in indicial notation as

$$T_i = C_{ij}E_j \quad i = 1, \quad 2 \dots 6. \quad (5.46.3)$$

However, it must be emphasized that the C_{ij} 's are not components of a second-order tensor and T_i 's are not those of a vector.

The symmetric matrix $[\mathbf{C}]$ is known as the *stiffness matrix* for the elastic solid. In the notation of Eq. (5.46.2), the strain energy U is given by

$$U = \frac{1}{2} [E_1 \ E_2 \ E_3 \ E_4 \ E_5 \ E_6] \begin{bmatrix} C_{11} & C_{12} & C_{13} & C_{14} & C_{15} & C_{16} \\ C_{12} & C_{22} & C_{23} & C_{24} & C_{25} & C_{26} \\ C_{13} & C_{23} & C_{33} & C_{34} & C_{35} & C_{36} \\ C_{14} & C_{24} & C_{34} & C_{44} & C_{45} & C_{46} \\ C_{15} & C_{25} & C_{35} & C_{45} & C_{55} & C_{56} \\ C_{16} & C_{26} & C_{36} & C_{46} & C_{56} & C_{66} \end{bmatrix} \begin{bmatrix} E_1 \\ E_2 \\ E_3 \\ E_4 \\ E_5 \\ E_6 \end{bmatrix}. \quad (5.46.4)$$

We require that the strain energy U be a positive definite function of the strain components. That is, it is zero if and only if all strain components are zero; otherwise, it is positive. Thus, the stiffness matrix is said to be a *positive definite matrix* that has among its properties (see the following example): (1) All diagonal elements are positive, i.e., $C_{ii} > 0$ (no sum on i for $i = 1, 2, \dots, 6$); (2) the determinant of $[\mathbf{C}]$ is positive, i.e., $\det \mathbf{C} > 0$; and (3) its inverse $[\mathbf{S}] = [\mathbf{C}]^{-1}$ exists and is also symmetric and positive definite (see Example 5.46.1.) The matrix $[\mathbf{S}]$ is known as the *compliance matrix*.

As mentioned at the beginning of this chapter, the assumption of the existence of a strain energy function is motivated by the concept of elasticity, which implies that all strain states of an elastic body requires positive work to be done on it and the work is completely used to increase the strain energy of the body.

Example 5.46.1

Show that for the matrix $[\mathbf{C}]$ defined in Eq. (5.46.2), (a) all the diagonal elements are positive, i.e., $C_{ii} > 0$ (no sum on i for $i = 1, 2, \dots, 6$), (b) not only the matrix $[\mathbf{C}]$ is positive definite, but all the submatrices

$$\begin{bmatrix} C_{11} & C_{12} \\ C_{12} & C_{22} \end{bmatrix}, \begin{bmatrix} C_{22} & C_{23} \\ C_{23} & C_{33} \end{bmatrix}, \begin{bmatrix} C_{11} & C_{12} & C_{13} \\ C_{12} & C_{22} & C_{23} \\ C_{13} & C_{23} & C_{33} \end{bmatrix}, \text{ etc.}$$

are positive definite, (c) the determinant of a positive definite matrix is positive, and (d) the inverses of all positive definite matrices are also positive definite.

Solution

(a) Consider first the case where only E_1 is nonzero, all other $E_i = 0$; then the strain energy is $U = C_{11}E_1^2/2$. Now $U > 0$; therefore $C_{11} > 0$. Similarly, if we consider the case where only E_2 is nonzero, then $U = C_{22}E_2^2/2$ so that $C_{22} > 0$, etc. Thus, all diagonal elements are positive, i.e., $C_{ii} > 0$ (no sum on i for $i = 1, 2, \dots, 6$) with respect to any basis.

(b) Consider the case where only E_1 and E_2 are nonzero, then

$$2U = [E_1 \ E_2] \begin{bmatrix} C_{11} & C_{12} \\ C_{12} & C_{22} \end{bmatrix} \begin{bmatrix} E_1 \\ E_2 \end{bmatrix} > 0.$$

That is, the submatrix of $[\mathbf{C}]$ shown in the preceding equation is positive definite. Next, consider the case where only E_2 and E_3 are nonzero; then

$$2U = [E_2 \ E_3] \begin{bmatrix} C_{22} & C_{23} \\ C_{23} & C_{33} \end{bmatrix} \begin{bmatrix} E_2 \\ E_3 \end{bmatrix} > 0.$$

That is, the submatrix of $[\mathbf{C}]$ shown in the preceding equation is positive definite. All such submatrices can be shown to be positive definite in a similar manner.

(c) If a positive definite matrix $[\mathbf{C}]$ is not invertible, then there must be a nonzero column matrix $[\mathbf{x}]$ such that $[\mathbf{C}][\mathbf{x}] = [\mathbf{0}]$; therefore, $[\mathbf{x}]^T[\mathbf{C}][\mathbf{x}] = 0$, which contradicts the assumption that $[\mathbf{C}]$ is positive definite. Thus, the determinant of a positive definite matrix is nonzero, its inverse exists. Since the eigenvalues of the real symmetric matrix $[\mathbf{C}]$ are the positive diagonal elements of a diagonal matrix, the determinant of $[\mathbf{C}]$ is positive.

(d) Consider $[b] = [C] [a]$, where $[a]$ is arbitrary. Let $[S]$ denote the inverse of $[C]$, then

$$[b]^T [S] [b] = [b]^T [C^{-1}] [b] = [a]^T [C] [C]^{-1} [C] [a] = [a]^T [C] [a] > 0.$$

That is, $[b]^T [S] [b] > 0$ so that $[S]$ is also positive definite.

5.47 PLANE OF MATERIAL SYMMETRY

Let S_1 be a plane whose normal is in the direction of \mathbf{e}_1 . The transformation

$$\mathbf{e}'_1 = -\mathbf{e}_1, \quad \mathbf{e}'_2 = \mathbf{e}_2, \quad \mathbf{e}'_3 = \mathbf{e}_3, \quad (5.47.1)$$

describes a reflection with respect to the plane S_1 . This transformation can be more conveniently represented by the tensor \mathbf{Q} in the equation

$$\mathbf{e}'_i = \mathbf{Q}\mathbf{e}_i, \quad (5.47.2)$$

where

$$[\mathbf{Q}] \equiv [\mathbf{Q}_1] = \begin{bmatrix} -1 & 0 & 0 \\ 0 & 1 & 0 \\ 0 & 0 & 1 \end{bmatrix}. \quad (5.47.3)$$

If the constitutive relations for a material, written with respect to the $\{\mathbf{e}_i\}$ basis, remain the same under the transformation $[\mathbf{Q}_1]$, then we say that the plane S_1 is a *plane of material symmetry* for that material. For a linearly elastic material, material symmetry with respect to the S_1 plane requires that the components of C_{ijkl} in the equation

$$T_{ij} = C_{ijkl}E_{kl}, \quad (5.47.4)$$

be exactly the same as C'_{ijkl} in the equation

$$T'_{ij} = C'_{ijkl}E'_{kl}, \quad (5.47.5)$$

under the transformation Eqs. (5.47.2) and (5.47.3). That is,

$$C'_{ijkl} = C_{ijkl}. \quad (5.47.6)$$

When this is the case, restrictions are imposed on the components of the elasticity tensor, thereby reducing the number of independent components. Let us first demonstrate this kind of reduction using a simpler example, relating the thermal strain with the rise in temperature in the following.

Example 5.47.1

Consider a homogeneous continuum undergoing a uniform temperature change given by $\Delta\theta = \theta - \theta_0$. Let the relation between the thermal strain e_{ij} and $\Delta\theta$ be given by

$$e_{ij} = \alpha_{ij}(\Delta\theta),$$

where α_{ij} is the thermal expansion coefficient tensor. (a) If the plane S_1 defined in Eq. (5.47.1) is a plane of symmetry for the thermal expansion property of the material, what restriction must be placed on the components of α_{ij} ? (b) If the

plane S_2 and S_3 , whose normal vectors are in the direction of \mathbf{e}_2 and \mathbf{e}_3 , respectively, are also planes of symmetry, what are the additional restrictions? In this case, the material is said to be *orthotropic* with respect to thermal expansion. (c) If every plane perpendicular to the S_3 plane is a plane of symmetry, what are the additional restrictions? In this case, the material is said to be thermally *transversely isotropic* with \mathbf{e}_3 as its axis of symmetry. (d) If both \mathbf{e}_1 and \mathbf{e}_3 are axes of transverse isotropy, how many constants are needed to describe the thermal expansion behavior of the material?

Solution

(a) Using the transformation law [see Eq. (2.18.5), Section 2.18, Chapter 2],

$$[\alpha]' = [\mathbf{Q}]^T [\alpha] [\mathbf{Q}], \quad (\text{i})$$

we obtain, with $[\mathbf{Q}_1]$ given by Eq. (5.47.3),

$$[\alpha]' = \begin{bmatrix} -1 & 0 & 0 \\ 0 & 1 & 0 \\ 0 & 0 & 1 \end{bmatrix} \begin{bmatrix} \alpha_{11} & \alpha_{12} & \alpha_{13} \\ \alpha_{21} & \alpha_{22} & \alpha_{23} \\ \alpha_{31} & \alpha_{32} & \alpha_{33} \end{bmatrix} \begin{bmatrix} -1 & 0 & 0 \\ 0 & 1 & 0 \\ 0 & 0 & 1 \end{bmatrix} = \begin{bmatrix} \alpha_{11} & -\alpha_{12} & -\alpha_{13} \\ -\alpha_{21} & \alpha_{22} & \alpha_{23} \\ -\alpha_{31} & \alpha_{32} & \alpha_{33} \end{bmatrix}. \quad (\text{ii})$$

The requirement that $[\alpha] = [\alpha]'$ under $[\mathbf{Q}_1]$ results in the following restrictions:

$$\alpha_{12} = -\alpha_{12} = 0, \quad \alpha_{21} = -\alpha_{21} = 0, \quad \alpha_{13} = -\alpha_{13} = 0, \quad \alpha_{31} = -\alpha_{31} = 0. \quad (\text{iii})$$

Thus, only five coefficients are needed to describe the thermo-expansion behavior if there is one plane of symmetry:

$$[\alpha] = \begin{bmatrix} \alpha_{11} & 0 & 0 \\ 0 & \alpha_{22} & \alpha_{23} \\ 0 & \alpha_{32} & \alpha_{33} \end{bmatrix}. \quad (\text{iv})$$

(b) Corresponding to the S_2 plane,

$$[\mathbf{Q}_2] = \begin{bmatrix} 1 & 0 & 0 \\ 0 & -1 & 0 \\ 0 & 0 & 1 \end{bmatrix}, \quad \text{so that } [\alpha]' = \begin{bmatrix} \alpha_{11} & 0 & 0 \\ 0 & \alpha_{22} & -\alpha_{23} \\ 0 & -\alpha_{32} & \alpha_{33} \end{bmatrix}. \quad (\text{v})$$

The requirement that $[\alpha] = [\alpha]'$ under \mathbf{Q}_2 , results in the following additional restrictions:

$$\alpha_{23} = \alpha_{32} = 0. \quad (\text{vi})$$

Thus, only three coefficients are needed to describe the thermo-expansion behavior if there are two mutually orthogonal planes of symmetry. That is, for *orthotropic thermal material*,

$$[\alpha] = \begin{bmatrix} \alpha_{11} & 0 & 0 \\ 0 & \alpha_{22} & 0 \\ 0 & 0 & \alpha_{33} \end{bmatrix}. \quad (\text{vii})$$

If the S_3 is also a plane of symmetry, then

$$[\mathbf{Q}_3] = \begin{bmatrix} 1 & 0 & 0 \\ 0 & 1 & 0 \\ 0 & 0 & -1 \end{bmatrix} \quad \text{and} \quad [\alpha] = \begin{bmatrix} \alpha_{11} & 0 & 0 \\ 0 & \alpha_{22} & 0 \\ 0 & 0 & \alpha_{33} \end{bmatrix}. \quad (\text{viii})$$

Thus, no further reduction takes place. That is, the symmetry with respect to S_1 and S_2 planes automatically ensures the symmetry with respect to the S_3 plane.

- (c) All planes that are perpendicular to the S_3 plane have their normal vectors parallel to the planes formed by \mathbf{e}_1 and \mathbf{e}_2 . Let

$$\mathbf{e}'_1 = \cos \beta \mathbf{e}_1 + \sin \beta \mathbf{e}_2, \quad \mathbf{e}'_2 = -\sin \beta \mathbf{e}_1 + \cos \beta \mathbf{e}_2, \quad \mathbf{e}'_3 = \mathbf{e}_3. \quad (\text{ix})$$

First we note that the \mathbf{e}_1 -plane corresponds to $\beta = 0$ and the \mathbf{e}_2 -plane corresponds to $\beta = 90^\circ$ so that symmetry with respect to the transformation given in Eq. (ix) includes orthotropic symmetry. Thus,

$$[\alpha]^\prime = \begin{bmatrix} \cos \beta & \sin \beta & 0 \\ -\sin \beta & \cos \beta & 0 \\ 0 & 0 & 1 \end{bmatrix} \begin{bmatrix} \alpha_{11} & 0 & 0 \\ 0 & \alpha_{22} & 0 \\ 0 & 0 & \alpha_{33} \end{bmatrix} \begin{bmatrix} \cos \beta & -\sin \beta & 0 \\ \sin \beta & \cos \beta & 0 \\ 0 & 0 & 1 \end{bmatrix}, \quad (\text{x})$$

so that we have

$$\begin{aligned} \alpha'_{11} &= \alpha_{11} \cos^2 \beta + \alpha_{22} \sin^2 \beta, & \alpha'_{22} &= \alpha_{11} \sin^2 \beta + \alpha_{22} \cos^2 \beta, & \alpha'_{33} &= \alpha_{33}, \\ \alpha'_{12} &= \alpha'_{21} = -\alpha_{11} \sin \beta \cos \beta + \alpha_{22} \sin \beta \cos \beta, & \alpha'_{13} &= 0, & \alpha'_{23} &= 0, & \alpha'_{31} &= 0, & \alpha'_{32} &= 0. \end{aligned} \quad (\text{xi})$$

Now, in addition, any S_β plane is a plane symmetry; therefore [see part (a)], $\alpha'_{12} = 0$ so that

$$\alpha_{11} = \alpha_{22}. \quad (\text{xii})$$

Thus, only two coefficients are needed to describe the thermal behavior of a transversely isotropic thermal material.

- (d) Finally, if the material is also transversely isotropic, with \mathbf{e}_1 as its axis of symmetry; then

$$\alpha_{22} = \alpha_{33}, \quad (\text{xiii})$$

so that

$$\alpha_{11} = \alpha_{22} = \alpha_{33}, \quad (\text{xiv})$$

and the material is isotropic with respect to thermal expansion, with only one coefficient needed for its description. This is the common case in elementary physics.

5.48 CONSTITUTIVE EQUATION FOR A MONOCLINIC LINEARLY ELASTIC SOLID

If a linearly elastic solid has one plane of material symmetry, it is called a *monoclinic material*. We shall demonstrate that for such a material, there are 13 independent elasticity coefficients.

Let \mathbf{e}_1 be normal to the plane of material symmetry S_1 . Then by definition, under the change of basis

$$\mathbf{e}'_1 = -\mathbf{e}_1, \quad \mathbf{e}'_2 = \mathbf{e}_2, \quad \mathbf{e}'_3 = \mathbf{e}_3, \quad (5.48.1)$$

the components of the fourth-order elasticity tensor remain unchanged, i.e.,

$$C'_{ijkl} = C_{ijkl}. \quad (5.48.2)$$

Now $C'_{ijkl} = Q_{mi}Q_{nj}Q_{rk}Q_{sl}C_{mnr}$ [see Section 2.19]; therefore, under Eq. (5.48.1),

$$C_{ijkl} = Q_{mi}Q_{nj}Q_{rk}Q_{sl}C_{mnr}, \quad (5.48.3)$$

where

$$Q_{11} = -1, \quad Q_{22} = Q_{33} = 1, \quad \text{and all other } Q_{ij} = 0. \quad (5.48.4)$$

From Eqs. (5.48.3) and (5.48.4), we have

$$C_{1112} = Q_{m1}Q_{n1}Q_{r1}Q_{s2}C_{mnr} = Q_{11}Q_{11}Q_{11}Q_{22}C_{1112} + 0 + 0 + \dots + 0 = (-1)^3(+1)C_{1112} = -C_{1112}. \quad (5.48.5)$$

Thus

$$C_{1112} = 0. \quad (5.48.6)$$

Indeed, one can easily see that all C_{ijkl} with an odd number of the subscript 1 are zero. That is, among the 21 independent coefficients, the following eight are zero:

$$C_{1112} = C_{1113} = C_{1222} = C_{1223} = C_{1233} = C_{1322} = C_{1323} = C_{1333} = 0, \quad (5.48.7)$$

so that the constitutive equations have only 13 nonzero independent coefficients. Thus, the stress strain laws for a *monoclinic elastic solid* having the x_2x_3 plane as the plane of symmetry are

$$\begin{bmatrix} T_{11} \\ T_{22} \\ T_{33} \\ T_{23} \\ T_{31} \\ T_{12} \end{bmatrix} = \begin{bmatrix} C_{1111} & C_{1122} & C_{1133} & C_{1123} & 0 & 0 \\ C_{1122} & C_{2222} & C_{2233} & C_{2223} & 0 & 0 \\ C_{1133} & C_{2233} & C_{3333} & C_{2333} & 0 & 0 \\ C_{1123} & C_{2223} & C_{2333} & C_{2323} & 0 & 0 \\ 0 & 0 & 0 & 0 & C_{1313} & C_{1213} \\ 0 & 0 & 0 & 0 & C_{1213} & C_{1212} \end{bmatrix} \begin{bmatrix} E_{11} \\ E_{22} \\ E_{33} \\ 2E_{23} \\ 2E_{31} \\ 2E_{12} \end{bmatrix}. \quad (5.48.8)$$

In contracted notation, the stiffness matrix is given by

$$[C] = \begin{bmatrix} C_{11} & C_{12} & C_{13} & C_{14} & 0 & 0 \\ C_{12} & C_{22} & C_{23} & C_{24} & 0 & 0 \\ C_{13} & C_{23} & C_{33} & C_{34} & 0 & 0 \\ C_{14} & C_{24} & C_{34} & C_{44} & 0 & 0 \\ 0 & 0 & 0 & 0 & C_{55} & C_{56} \\ 0 & 0 & 0 & 0 & C_{56} & C_{66} \end{bmatrix}. \quad (5.48.9)$$

The coefficients in the stiffness matrix C must satisfy the conditions that each diagonal element $C_{ii} > 0$ (no sum on i , for $i = 1, 2, \dots, 6$) and the determinant of every submatrix whose diagonal elements are diagonal elements of the matrix C is positive definite (see Section 5.46).

5.49 CONSTITUTIVE EQUATION FOR AN ORTHOTROPIC LINEARLY ELASTIC SOLID

If a linearly elastic solid has two mutually perpendicular planes of material symmetry, say, S_1 plane with unit normal \mathbf{e}_1 and S_2 plane with unit normal \mathbf{e}_2 , then automatically the S_3 plane with unit normal \mathbf{e}_3 is also a plane of material symmetry. The material is called an *orthotropic elastic material*. We shall demonstrate that for such a material, there are only nine independent elastic coefficients. For this solid, the coefficients

C_{ijkl} now must be invariant with respect to the transformation given by Eq. (5.48.1) of Section 5.48 as well as the following transformation:

$$\mathbf{e}'_1 = \mathbf{e}_1, \quad \mathbf{e}'_2 = -\mathbf{e}_2, \quad \mathbf{e}'_3 = \mathbf{e}_3. \quad (5.49.1)$$

Thus, among the 13 C_{ijkl} that appear in Eq. (5.48.9), those which have an odd number of the subscript 2 must also be zero. For example,

$$\begin{aligned} C_{1123} &= Q_{m1}Q_{n1}Q_{r2}Q_{s3}C_{mnr s} = Q_{11}Q_{11}Q_{22}Q_{33}C_{1123} + 0 + 0 + \dots + 0 = (1)^2(-1)(1)C_{1123}, \\ &= -C_{1123} = 0. \end{aligned} \quad (i)$$

$$\begin{aligned} C_{2223} &= Q_{m2}Q_{n2}Q_{r2}Q_{s3}C_{mnr s} = Q_{22}Q_{22}Q_{22}Q_{33}C_{2223} + 0 + 0 + \dots + 0 = (-1)^3(1)C_{2223}, \\ &= -C_{2223} = 0. \end{aligned} \quad (ii)$$

Thus,

$$C_{1123} = C_{2223} = C_{2333} = C_{1213} = 0. \quad (5.49.2)$$

Therefore, there are now only nine independent coefficients and the constitutive equations become

$$\begin{bmatrix} T_{11} \\ T_{22} \\ T_{33} \\ T_{23} \\ T_{31} \\ T_{12} \end{bmatrix} = \begin{bmatrix} C_{1111} & C_{1122} & C_{1133} & 0 & 0 & 0 \\ C_{1122} & C_{2222} & C_{2233} & 0 & 0 & 0 \\ C_{1133} & C_{2233} & C_{3333} & 0 & 0 & 0 \\ 0 & 0 & 0 & C_{2323} & 0 & 0 \\ 0 & 0 & 0 & 0 & C_{1313} & 0 \\ 0 & 0 & 0 & 0 & 0 & C_{1212} \end{bmatrix} \begin{bmatrix} E_{11} \\ E_{22} \\ E_{33} \\ 2E_{23} \\ 2E_{31} \\ 2E_{12} \end{bmatrix}. \quad (5.49.3)$$

Or, in contracted notation, the stiffness matrix is given by

$$[C] = \begin{bmatrix} C_{11} & C_{12} & C_{13} & 0 & 0 & 0 \\ C_{12} & C_{22} & C_{23} & 0 & 0 & 0 \\ C_{13} & C_{23} & C_{33} & 0 & 0 & 0 \\ 0 & 0 & 0 & C_{44} & 0 & 0 \\ 0 & 0 & 0 & 0 & C_{55} & 0 \\ 0 & 0 & 0 & 0 & 0 & C_{66} \end{bmatrix}, \quad (5.49.4)$$

where again, each diagonal element $C_{ii} > 0$ (no sum on i) for $i = 1, 2, \dots, 6$ and the determinant of every submatrix whose diagonal elements are diagonal elements of the matrix \mathbf{C} is positive definite. That is,

$$\det \begin{bmatrix} C_{11} & C_{12} \\ C_{21} & C_{22} \end{bmatrix} > 0, \quad \det \begin{bmatrix} C_{11} & C_{13} \\ C_{31} & C_{33} \end{bmatrix} > 0, \quad \det \begin{bmatrix} C_{22} & C_{23} \\ C_{32} & C_{33} \end{bmatrix} > 0 \quad \text{and} \quad \det[C] > 0 \quad (5.49.5)$$

5.50 CONSTITUTIVE EQUATION FOR A TRANSVERSELY ISOTROPIC LINEARLY ELASTIC MATERIAL

If there exists a plane, say, S_3 -plane, such that every plane perpendicular to it is a plane of symmetry, then the material is called a *transversely isotropic material*. The S_3 -plane is called the *plane of isotropy* and its normal direction \mathbf{e}_3 is the *axis of transverse isotropy*.

Let $\{\mathbf{e}_1, \mathbf{e}_2\}$ and $\{\mathbf{e}'_1, \mathbf{e}'_2\}$ be two sets of orthonormal bases lying on the S_3 plane where \mathbf{e}'_1 makes an angle of β with the \mathbf{e}_1 -axis. We have

$$\mathbf{e}'_1 = \cos \beta \mathbf{e}_1 + \sin \beta \mathbf{e}_2, \quad \mathbf{e}'_2 = -\sin \beta \mathbf{e}_1 + \cos \beta \mathbf{e}_2, \quad \mathbf{e}'_3 = \mathbf{e}_3. \quad (5.50.1)$$

That is,

$$Q_{11} = \cos \beta, \quad Q_{21} = \sin \beta, \quad Q_{12} = -\sin \beta, \quad Q_{22} = \cos \beta, \quad Q_{31} = Q_{32} = 0, \quad Q_{33} = 1. \quad (5.50.2)$$

Now, every β in Eq. (5.50.2) defines an orthonormal basis $(\mathbf{e}'_1, \mathbf{e}'_2, \mathbf{e}'_3)$ with respect to which the material is orthotropic. Thus for every β , we have, from the results of the previous section,

$$\begin{aligned} C'_{1112} &= C'_{1113} = C'_{1222} = C'_{1223} = C'_{1233} = C'_{1322} = C'_{1323} = C'_{1333}, \\ &= C'_{1123} = C'_{2223} = C'_{2333} = C'_{1213} = 0 \end{aligned} \quad (5.50.3)$$

including at $\beta = 0$,

$$\begin{aligned} C_{1112} &= C_{1113} = C_{1222} = C_{1223} = C_{1233} = C_{1322} = C_{1323} = C_{1333}, \\ &= C_{1123} = C_{2223} = C_{2333} = C_{1213} = 0. \end{aligned} \quad (5.50.4)$$

Next, from Eq. (5.50.2), we have

$$\begin{aligned} C'_{1323} &= Q_{m1}Q_{n3}Q_{r2}Q_{s3}C_{mnr3} = Q_{m1}Q_{33}Q_{r2}Q_{33}C_{m3r3} = Q_{m1}Q_{r2}C_{m3r3} \\ &= Q_{11}Q_{12}C_{1313} + Q_{11}Q_{22}C_{1323} + Q_{21}Q_{12}C_{2313} + Q_{21}Q_{22}C_{2323} \\ &= Q_{11}Q_{12}C_{1313} + Q_{21}Q_{22}C_{2323}. \end{aligned} \quad (5.50.5)$$

That is,

$$C'_{1323} = \cos \beta \sin \beta (-C_{1313} + C_{2323}). \quad (5.50.6)$$

But, from Eq. (5.50.3), $C'_{1323} = 0$; therefore,

$$C_{1313} = C_{2323}. \quad (5.50.7)$$

Similar, $C'_{1233} = 0$ leads to (see Prob. 5.96)

$$C_{1133} = C_{2233}. \quad (5.50.8)$$

Furthermore, since $Q_{21} = -Q_{12} = \sin \beta$, $Q_{11} = Q_{22} = \cos \beta$, $Q_{31} = Q_{32} = 0$, $Q_{33} = 1$ and $C_{1122} = C_{2211}$, $C_{1212} = C_{2121} = C_{1221} = C_{2112}$, $C_{1112} = C_{1222} = 0$, we have

$$\begin{aligned} C'_{1112} &= Q_{m1}Q_{n1}Q_{r1}Q_{s2}C_{mnr3} = Q_{11}Q_{12} \\ &[Q_{11}Q_{11}C_{1111} - (Q_{11}Q_{22} - Q_{21}Q_{21})C_{1122} - 2(Q_{11}Q_{22} - Q_{21}Q_{21})C_{1212} - Q_{21}Q_{21}C_{2222}] \end{aligned} \quad (5.50.9)$$

Thus, $C'_{1112} = 0$ gives

$$\cos^2 \beta C_{1111} - (\cos^2 \beta - \sin^2 \beta)C_{1122} - 2(\cos^2 \beta - \sin^2 \beta)C_{1212} - \sin^2 \beta C_{2222} = 0. \quad (5.50.10)$$

Similarly, we can obtain from the equation $C'_{1222} = 0$ (see Prob. 5.97) that

$$\sin^2 \beta C_{1111} + (\cos^2 \beta - \sin^2 \beta)C_{1122} + 2(\cos^2 \beta - \sin^2 \beta)C_{1212} - \cos^2 \beta C_{2222} = 0. \quad (5.50.11)$$

Adding Eqs. (5.50.10) and (5.50.11), or by taking $\beta = \pi/4$ in either equation, we obtain

$$C_{1111} = C_{2222}. \quad (5.50.12)$$

We note that the results expressed in Eqs. (5.50.7), (5.50.8), and (5.50.12) are quite self-evident in that, with \mathbf{e}_3 as the axis of transverse symmetry, there is no distinction between the \mathbf{e}_1 basis and the \mathbf{e}_2 basis. Finally, subtracting Eq. (5.50.10) from (5.50.11), we have

$$(C_{1111} - 2C_{1122} - 4C_{1212} + C_{2222}) = 0. \quad (5.50.13)$$

Thus,

$$C_{1212} = \frac{1}{2}(C_{1111} - C_{1122}). \quad (5.50.14)$$

Equations (5.50.12) and (5.50.14) can also be obtained from Eqs. (5.50.10) and (5.50.11) by taking $\beta = \pi/2$ in these equations.

Thus, the number of independent coefficients reduces to five and we have, for a transversely isotropic elastic solid with the axis of symmetry in the \mathbf{e}_3 direction, the following stress strain law:

$$\begin{bmatrix} T_{11} \\ T_{22} \\ T_{33} \\ T_{23} \\ T_{31} \\ T_{12} \end{bmatrix} = \begin{bmatrix} C_{1111} & C_{1122} & C_{1133} & 0 & 0 & 0 \\ C_{1122} & C_{1111} & C_{1133} & 0 & 0 & 0 \\ C_{1133} & C_{1133} & C_{3333} & 0 & 0 & 0 \\ 0 & 0 & 0 & C_{1313} & 0 & 0 \\ 0 & 0 & 0 & 0 & C_{1313} & 0 \\ 0 & 0 & 0 & 0 & 0 & (1/2)(C_{1111} - C_{1122}) \end{bmatrix} \begin{bmatrix} E_{11} \\ E_{22} \\ E_{33} \\ 2E_{23} \\ 2E_{31} \\ 2E_{12} \end{bmatrix}, \quad (5.50.15)$$

and in contracted notation, the stiffness matrix is

$$[C] = \begin{bmatrix} C_{11} & C_{12} & C_{13} & 0 & 0 & 0 \\ C_{12} & C_{11} & C_{13} & 0 & 0 & 0 \\ C_{13} & C_{13} & C_{33} & 0 & 0 & 0 \\ 0 & 0 & 0 & C_{44} & 0 & 0 \\ 0 & 0 & 0 & 0 & C_{44} & 0 \\ 0 & 0 & 0 & 0 & 0 & (1/2)(C_{11} - C_{12}) \end{bmatrix}. \quad (5.50.16)$$

The elements of the stiffness matrix satisfy the condition

$$\begin{aligned} C_{11} > 0, \quad C_{33} > 0, \quad C_{44} > 0, \quad C_{11} - C_{12} > 0, \\ \det \begin{bmatrix} C_{11} & C_{12} \\ C_{12} & C_{11} \end{bmatrix} = C_{11}^2 - C_{12}^2 > 0, \quad \det \begin{bmatrix} C_{11} & C_{13} \\ C_{13} & C_{33} \end{bmatrix} = C_{11}C_{33} - C_{13}^2 > 0, \\ \det \begin{bmatrix} C_{11} & C_{12} & C_{13} \\ C_{12} & C_{11} & C_{13} \\ C_{13} & C_{13} & C_{33} \end{bmatrix} = C_{11}^2C_{33} + 2C_{12}C_{13}^2 - 2C_{11}C_{13}^2 - C_{33}C_{12}^2 > 0. \end{aligned} \quad (5.50.17)$$

5.51 CONSTITUTIVE EQUATION FOR AN ISOTROPIC LINEARLY ELASTIC SOLID

The stress-strain equations given in the last section are for a transversely isotropic elastic solid whose axis of transverse isotropy is in the \mathbf{e}_3 direction. If, in addition, \mathbf{e}_1 is also an axis of transverse isotropy, then clearly, we have

$$C_{2222} = C_{3333} = C_{1111}, \quad C_{1122} = C_{1133}, \quad C_{1313} = C_{1212} = (C_{1111} - C_{1122})/2. \quad (5.51.1)$$

Or, in contracted notation

$$C_{22} = C_{33} = C_{11}, \quad C_{12} = C_{13}, \quad C_{44} = (C_{11} - C_{12})/2. \quad (5.51.2)$$

There are now only two independent coefficients and the stress strain law is

$$\begin{bmatrix} T_{11} \\ T_{22} \\ T_{33} \\ T_{23} \\ T_{31} \\ T_{12} \end{bmatrix} = \begin{bmatrix} C_{11} & C_{12} & C_{12} & 0 & 0 & 0 \\ C_{12} & C_{11} & C_{12} & 0 & 0 & 0 \\ C_{12} & C_{12} & C_{11} & 0 & 0 & 0 \\ 0 & 0 & 0 & (C_{11} - C_{12})/2 & 0 & 0 \\ 0 & 0 & 0 & 0 & (C_{11} - C_{12})/2 & 0 \\ 0 & 0 & 0 & 0 & 0 & (C_{11} - C_{12})/2 \end{bmatrix} \begin{bmatrix} E_{11} \\ E_{22} \\ E_{33} \\ 2E_{23} \\ 2E_{31} \\ 2E_{12} \end{bmatrix}, \quad (5.51.3)$$

where

$$C_{11} > 0, \quad C_{11} - C_{12} > 0, \quad C_{11}^2 - C_{12}^2 > 0, \quad C_{11}^3 + 2C_{12}^3 - 3C_{11}C_{12}^2 > 0. \quad (5.51.4)$$

The elements C_{ij} are related to the Lamé's constants λ and μ as follows:

$$C_{11} = \lambda + 2\mu, \quad C_{12} = \lambda, \quad (C_{11} - C_{12}) = 2\mu. \quad (5.51.5)$$

5.52 ENGINEERING CONSTANTS FOR AN ISOTROPIC LINEARLY ELASTIC SOLID

Since the stiffness matrix is positive definite, the stress-strain law can be inverted to give the strain components in terms of the stress components. They can be written in the following form:

$$\begin{bmatrix} E_{11} \\ E_{22} \\ E_{33} \\ 2E_{23} \\ 2E_{31} \\ 2E_{12} \end{bmatrix} = \begin{bmatrix} 1/E_Y & -\nu/E_Y & -\nu/E_Y & 0 & 0 & 0 \\ -\nu/E_Y & 1/E_Y & -\nu/E_Y & 0 & 0 & 0 \\ -\nu/E_Y & -\nu/E_Y & 1/E_Y & 0 & 0 & 0 \\ 0 & 0 & 0 & 1/G & 0 & 0 \\ 0 & 0 & 0 & 0 & 1/G & 0 \\ 0 & 0 & 0 & 0 & 0 & 1/G \end{bmatrix} \begin{bmatrix} T_{11} \\ T_{22} \\ T_{33} \\ T_{23} \\ T_{31} \\ T_{12} \end{bmatrix}, \quad (5.52.1)$$

whereas we already know from Section 5.4, E_Y is Young's modulus, ν is Poisson's ratio, and G is the shear modulus, and

$$G = \frac{E}{2(1 + \nu)}. \quad (5.52.2)$$

The compliance matrix is positive definite. Therefore, the diagonal elements and the submatrices are all positive; that is,

$$E_Y > 0, \quad G > 0, \quad (5.52.3)$$

$$\det \begin{bmatrix} 1/E_Y & -\nu/E_Y \\ -\nu/E_Y & 1/E_Y \end{bmatrix} = (1/E_Y)^2 (1 - \nu^2) > 0, \quad (5.52.4)$$

$$\det \begin{bmatrix} 1/E_Y & -\nu/E_Y & -\nu/E_Y \\ -\nu/E_Y & 1/E_Y & -\nu/E_Y \\ -\nu/E_Y & -\nu/E_Y & 1/E_Y \end{bmatrix} = (1/E_Y)^3 (1 - 2\nu^3 - 3\nu^2) = (1/E_Y)^3 (1 - 2\nu)(1 + \nu)^2 > 0. \quad (5.52.5)$$

Eqs. (5.52.4) and (5.52.5) state that

$$-1 < \nu < 1/2. \quad (5.52.6)$$

5.53 ENGINEERING CONSTANTS FOR A TRANSVERSELY ISOTROPIC LINEARLY ELASTIC SOLID

For a transversely isotropic elastic solid, the symmetric stiffness matrix with five independent coefficients can be inverted to give a symmetric compliance matrix, also with five independent constants. The strain-stress equations can be written in the following form for the case where \mathbf{e}_3 is the axis of transverse isotropy:

$$\begin{bmatrix} E_{11} \\ E_{22} \\ E_{33} \\ 2E_{23} \\ 2E_{31} \\ 2E_{12} \end{bmatrix} = \begin{bmatrix} 1/E_1 & -\nu_{21}/E_1 & -\nu_{31}/E_3 & 0 & 0 & 0 \\ -\nu_{21}/E_1 & 1/E_1 & -\nu_{31}/E_3 & 0 & 0 & 0 \\ -\nu_{13}/E_1 & -\nu_{13}/E_1 & 1/E_3 & 0 & 0 & 0 \\ 0 & 0 & 0 & 1/G_{13} & 0 & 0 \\ 0 & 0 & 0 & 0 & 1/G_{13} & 0 \\ 0 & 0 & 0 & 0 & 0 & 1/G_{12} \end{bmatrix} \begin{bmatrix} T_{11} \\ T_{22} \\ T_{33} \\ T_{23} \\ T_{31} \\ T_{12} \end{bmatrix}. \quad (5.53.1)$$

The relations between C_{ij} and the engineering constants can be obtained to be (see Prob. 5.99)

$$C_{11} = \frac{E_1}{(1 + \nu_{21})} \frac{[1 - \nu_{31}^2(E_1/E_3)]}{D}, \quad C_{22} = C_{11}, \quad C_{33} = \frac{E_1}{(1 + \nu_{21})} \frac{[1 - \nu_{21}^2(E_3/E_1)]}{D}, \quad (5.53.2)$$

$$C_{12} = \frac{E_1(\nu_{21} + \nu_{31}^2 E_1/E_3)}{(1 + \nu_{21})D}, \quad C_{13} = \frac{\nu_{31}E_1}{D} = C_{23}. \quad (5.53.3)$$

where

$$D = 1 - \nu_{21} - 2\nu_{31}^2(E_1/E_3), \quad (5.53.4)$$

and

$$C_{44} = G_{13}, \quad (C_{11} - C_{12})/2 = G_{12}. \quad (5.53.5)$$

From Eq. (5.53.2), it can be obtained (see Prob. 5.100) that

$$G_{12} = \frac{E_1}{2(1 + \nu_{21})}. \quad (5.53.6)$$

The compliance matrix is symmetric, so we have

$$\nu_{31}/E_3 = \nu_{13}/E_1. \quad (5.53.7)$$

We note that, with Eqs. (5.53.6) and (5.53.7), there are only five independent constants in the compliance matrix. They are E_1 , E_3 , G_{12} , G_{13} , and ν_{13} . The meaning of these constants will be clear from the following consideration:

(a) If T_{33} is the only nonzero stress component, then

$$E_{33} = T_{33}/E_3, \quad \nu_{31} = -E_{11}/E_{33} = -E_{22}/E_{33}. \quad (i)$$

Thus, E_3 is the Young's modulus in the \mathbf{e}_3 direction (the direction of the axis of transverse isotropy), and ν_{31} is the Poisson's ratio for the transverse strain in the x_1 or x_2 direction when stressed in the x_3 direction.

(b) If T_{11} is the only nonzero stress component, then

$$E_{11} = T_{11}/E_1, \quad v_{21} = -E_{22}/E_{11} \quad \text{and} \quad v_{13} = -E_{33}/E_{11}, \quad (\text{ii})$$

and if T_{22} is the only nonzero stress component, then

$$E_{22} = T_{22}/E_1, \quad v_{21} = -E_{11}/E_{22} \quad \text{and} \quad v_{13} = -E_{33}/E_{22}. \quad (\text{iii})$$

Thus, E_1 is the Young's modulus in the \mathbf{e}_1 and \mathbf{e}_2 directions (indeed, any direction perpendicular to the axis of transverse isotropy); v_{21} is the Poisson's ratio for the transverse strain in the x_2 direction when stressed in the x_1 direction, which is also the Poisson's ratio for the transverse strain in the x_1 direction when stressed in the x_2 direction; and v_{13} is the Poisson's ratio for the strain in the \mathbf{e}_3 direction when stressed in a direction in the plane of isotropy.

(c) From $T_{12} = 2G_{12}E_{12}$, $T_{23} = 2G_{13}E_{23}$, $T_{31} = 2G_{13}E_{31}$, we see that G_{12} is the shear modulus in the x_1x_2 plane (the plane of transverse isotropy) and G_{13} is the shear modulus in planes perpendicular to the plane of transverse isotropy.

From the meaning of E_1 , v_{21} , and G_{12} , we see clearly why Eq. (5.53.6) is of the same form as that of the relation among Young's modulus, shear modulus, and Poisson's ratio for an isotropic solid.

Since the compliance matrix is positive definite,

$$E_1 > 0, \quad E_3 > 0, \quad G_{12} > 0, \quad G_{13} > 0, \quad (\text{5.53.8})$$

$$\det \begin{bmatrix} 1/E_1 & -v_{21}/E_1 \\ -v_{21}/E_1 & 1/E_1 \end{bmatrix} = \frac{1}{E_1^2} (1 - v_{21}^2) > 0, \quad \text{i.e.,} \quad -1 < v_{21} < 1, \quad (\text{5.53.9})$$

$$\det \begin{bmatrix} 1/E_1 & -v_{31}/E_3 \\ -v_{31}/E_3 & 1/E_3 \end{bmatrix} = \frac{1}{E_1 E_3} \left(1 - v_{31}^2 \frac{E_1}{E_3} \right) > 0, \quad \text{i.e.,} \quad v_{31}^2 < \frac{E_3}{E_1} \quad \text{or} \quad v_{13} v_{31} < 1. \quad (\text{5.53.10})$$

The last inequality is obtained by using Eq. (5.53.7), i.e., $v_{31}/E_3 = v_{13}/E_1$. We also have

$$\begin{aligned} \det \begin{bmatrix} 1/E_1 & -v_{21}/E_1 & -v_{31}/E_3 \\ -v_{21}/E_1 & 1/E_1 & -v_{31}/E_3 \\ -v_{31}/E_3 & -v_{31}/E_3 & 1/E_3 \end{bmatrix} &= \frac{1}{E_1^2 E_3} \left[1 - 2v_{21}v_{31}^2 \left(\frac{E_1}{E_3} \right) - 2v_{31}^2 \left(\frac{E_1}{E_3} \right) - v_{21}^2 \right] \\ &= \frac{1}{E_1^2 E_3} \left[1 - 2v_{31}^2 \left(\frac{E_1}{E_3} \right) - v_{21} \right] (1 + v_{21}) > 0. \end{aligned} \quad (\text{5.53.11})$$

Since $(1 + v_{21}) > 0$, we have

$$1 - 2v_{31}^2 \left(\frac{E_1}{E_3} \right) > v_{21} \quad \text{or} \quad 1 - 2v_{31}v_{13} > v_{21}. \quad (\text{5.53.12})$$

5.54 ENGINEERING CONSTANTS FOR AN ORTHOTROPIC LINEARLY ELASTIC SOLID

For an orthotropic elastic solid, the symmetric stiffness matrix with nine independent coefficients can be inverted to give a symmetric compliance matrix, also with nine independent constants. The strain-stress equations can be written

$$\begin{bmatrix} E_{11} \\ E_{22} \\ E_{33} \\ 2E_{23} \\ 2E_{31} \\ 2E_{12} \end{bmatrix} = \begin{bmatrix} 1/E_1 & -v_{21}/E_2 & -v_{31}/E_3 & 0 & 0 & 0 \\ -v_{12}/E_1 & 1/E_2 & -v_{32}/E_3 & 0 & 0 & 0 \\ -v_{13}/E_1 & -v_{23}/E_2 & 1/E_3 & 0 & 0 & 0 \\ 0 & 0 & 0 & 1/G_{23} & 0 & 0 \\ 0 & 0 & 0 & 0 & 1/G_{31} & 0 \\ 0 & 0 & 0 & 0 & 0 & 1/G_{12} \end{bmatrix} \begin{bmatrix} T_{11} \\ T_{22} \\ T_{33} \\ T_{23} \\ T_{31} \\ T_{12} \end{bmatrix}, \quad (5.54.1)$$

where

$$v_{21}/E_2 = v_{12}/E_1, \quad v_{31}/E_3 = v_{13}/E_1, \quad v_{32}/E_3 = v_{23}/E_2. \quad (5.54.2)$$

The meaning of the constants in the compliance matrix can be obtained in the same way as in the previous section for the transversely isotropic solid. Thus, E_1 , E_2 and E_3 are the Young's modulus in the \mathbf{e}_1 , \mathbf{e}_2 and \mathbf{e}_3 directions, respectively; G_{23} , G_{31} and G_{12} are shear modulus in the x_2x_3 , x_1x_3 and x_1x_2 planes, respectively, and v_{ij} is Poisson's ratio for transverse strain in the j -direction when stressed in the i -direction.

The relationship between C_{ij} and the engineering constants are given by (see Prob. 5.101):

$$C_{11} = \frac{1 - v_{23}v_{32}}{E_2E_3\Delta}, \quad C_{22} = \frac{1 - v_{31}v_{13}}{E_3E_1\Delta}, \quad C_{33} = \frac{1 - v_{12}v_{21}}{E_1E_2\Delta}, \quad (5.54.3)$$

$$C_{12} = \frac{1}{E_2E_3\Delta}(v_{21} + v_{31}v_{23}), \quad C_{13} = \frac{1}{E_2E_3\Delta}(v_{31} + v_{21}v_{32}), \quad (5.54.4)$$

$$C_{23} = \frac{1}{E_1E_3\Delta}(v_{32} + v_{31}v_{12}),$$

where

$$\Delta = \frac{[1 - 2v_{13}v_{21}v_{32} - v_{13}v_{31} - v_{23}v_{32} - v_{21}v_{12}]}{E_1E_2E_3} \quad (5.54.5)$$

and

$$C_{44} = G_{23}, \quad C_{55} = G_{31}, \quad C_{66} = G_{12}. \quad (5.54.6)$$

For the compliance matrix, being positive definite, its diagonal elements and the submatrices are all positive; therefore, we have the following restrictions (see Prob. 5.102):

$$E_1 > 0, \quad E_2 > 0, \quad E_3 > 0, \quad G_{23} > 0, \quad G_{31} > 0, \quad G_{12} > 0. \quad (5.54.7)$$

$$v_{21}^2 < \frac{E_2}{E_1}, \quad v_{12}^2 < \frac{E_1}{E_2}, \quad v_{32}^2 < \frac{E_3}{E_2}, \quad v_{23}^2 < \frac{E_2}{E_3}, \quad v_{13}^2 < \frac{E_1}{E_3}, \quad v_{31}^2 < \frac{E_3}{E_1}, \quad (5.54.8)$$

and

$$1 - 2v_{13}v_{21}v_{32} - v_{13}v_{31} - v_{23}v_{32} - v_{21}v_{12} > 0. \quad (5.54.9)$$

5.55 ENGINEERING CONSTANTS FOR A MONOCLINIC LINEARLY ELASTIC SOLID

For a monoclinic elastic solid, the symmetric stiffness matrix with 13 independent coefficients can be inverted to give a symmetric compliance matrix, also with 13 independent constants. The compliance matrix for the case where the \mathbf{e}_1 plane is the plane of symmetric can be written as follows:

$$\begin{bmatrix} E_{11} \\ E_{22} \\ E_{33} \\ 2E_{23} \\ 2E_{31} \\ 2E_{12} \end{bmatrix} = \begin{bmatrix} 1/E_1 & -v_{21}/E_2 & -v_{31}/E_3 & \eta_{41}/G_4 & 0 & 0 \\ -v_{12}/E_1 & 1/E_2 & -v_{32}/E_3 & \eta_{42}/G_4 & 0 & 0 \\ -v_{13}/E_1 & -v_{23}/E_2 & 1/E_3 & \eta_{43}/G_4 & 0 & 0 \\ \eta_{14}/E_1 & \eta_{24}/E_2 & \eta_{34}/E_3 & 1/G_4 & 0 & 0 \\ 0 & 0 & 0 & 0 & 1/G_5 & \mu_{65}/G_6 \\ 0 & 0 & 0 & 0 & \mu_{56}/G_5 & 1/G_6 \end{bmatrix} \begin{bmatrix} T_{11} \\ T_{22} \\ T_{33} \\ T_{23} \\ T_{31} \\ T_{12} \end{bmatrix}. \quad (5.55.1)$$

The symmetry of the compliance matrix requires that

$$\begin{aligned} v_{21}/E_2 = v_{12}/E_1, \quad v_{31}/E_3 = v_{13}/E_1, \quad v_{32}/E_3 = v_{23}/E_2, \\ \eta_{14}/E_1 = \eta_{41}/G_4, \quad \eta_{24}/E_2 = \eta_{42}/G_4, \quad \eta_{34}/E_3 = \eta_{43}/G_4, \quad \mu_{56}/G_5 = \mu_{65}/G_6. \end{aligned} \quad (5.55.2)$$

With Eqs. (5.55.2), there are only 13 independent constants in Eq. (5.55.1):

$$E_1, E_2, E_3, G_4, G_5, G_6, v_{12}, v_{13}, v_{23}, \eta_{14}, \eta_{24}, \eta_{34} \text{ and } \mu_{56}.$$

If only T_{11} is nonzero, then the strain-stress law gives

$$E_{11} = \frac{T_{11}}{E_1}, \quad v_{12} = -\frac{E_{22}}{E_{11}}, \quad v_{13} = -\frac{E_{33}}{E_{11}}, \quad 2E_{23} = \eta_{14}E_{11}, \quad (5.53.3)$$

and if only T_{22} is nonzero, then the strain-stress law gives

$$E_{22} = \frac{T_{22}}{E_2}, \quad v_{21} = -\frac{E_{11}}{E_{22}}, \quad v_{23} = -\frac{E_{33}}{E_{22}}, \quad 2E_{23} = \eta_{24}E_{22}, \text{ etc.} \quad (5.54.4)$$

Thus, E_1 , E_2 and E_3 are Young's modulus in the x_1 , x_2 and x_3 directions, respectively, and again, v_{ij} is Poisson's ratio for transverse strain in the j -direction when stressed in the i direction. We note also that for a monoclinic elastic solid with the \mathbf{e}_1 -plane as its plane of symmetry, a uniaxial stress in the x_1 -direction or x_2 -direction produces a shear strain in the x_2x_3 plane also, with η_{ij} as the coupling coefficients.

If only $T_{12} = T_{21}$ are nonzero, then

$$T_{12} = 2G_6E_{12} \quad \text{and} \quad 2E_{31} = \mu_{65} \frac{T_{12}}{G_6}, \quad (5.55.5)$$

and if only $T_{13} = T_{31}$ are nonzero, then

$$T_{13} = 2G_5E_{13} \quad \text{and} \quad 2E_{12} = \mu_{56} \frac{T_{13}}{G_5}. \quad (5.55.6)$$

Thus, G_6 is the shear modulus in the x_1x_2 plane and G_5 is the shear modulus in the x_1x_3 plane. Note also that the shear stresses in the x_1x_2 plane produce, in addition to shear strain in the x_1x_2 plane but also shear strain in the x_1x_3 plane, and vice versa, with μ_{ij} as the coupling coefficients.

Finally, if only $T_{23} = T_{32}$ are nonzero, then

$$E_{11} = \eta_{41} \frac{T_{23}}{G_4}, \quad E_{22} = \eta_{42} \frac{T_{23}}{G_4}, \quad E_{33} = \eta_{43} \frac{T_{23}}{G_4}, \quad T_{23} = 2G_4E_{23}. \quad (5.55.7)$$

We see that G_4 is the shear modulus in the x_2x_3 plane, and the shear stress in this plane produces normal strains in the three coordinate directions, with η_{ij} as the normal stress-shear stress coupling coefficients.

Obviously, due to the positive definiteness of the compliance matrix, all the Young's moduli and the shear moduli are positive. Other restrictions regarding the engineering constants can be obtained in the same way as in the previous sections.

PROBLEMS FOR PART B

5.91 Demonstrate that if only E_2 and E_3 are nonzero, then Eq. (5.46.4) becomes

$$2U = [E_2 \quad E_3] \begin{bmatrix} C_{22} & C_{23} \\ C_{32} & C_{33} \end{bmatrix} \begin{bmatrix} E_2 \\ E_3 \end{bmatrix}.$$

5.92 Demonstrate that if only E_1 and E_3 are nonzero, then Eq. (5.46.4) becomes

$$2U = [E_1 \quad E_3] \begin{bmatrix} C_{11} & C_{13} \\ C_{31} & C_{33} \end{bmatrix} \begin{bmatrix} E_1 \\ E_3 \end{bmatrix}.$$

5.93 Write stress strain laws for a monoclinic elastic solid in contracted notation whose plane of symmetry is the x_1x_2 plane.

5.94 Write stress strain laws for a monoclinic elastic solid in contracted notation whose plane of symmetry is the x_1x_3 plane.

5.95 For transversely isotropic solid with \mathbf{e}_3 as the axis of transverse isotropy, show from the transformation law $C'_{ijkl} = Q_{mi}Q_{nj}Q_{rk}Q_{sl}C_{mnr}$ that $C'_{1113} = 0$ (see Section 5.50).

5.96 Show that for a transversely isotropic elastic material with \mathbf{e}_3 as the axis of transverse isotropy, $C_{1133} = C_{2233}$, by demanding that each S_β plane is a plane of material symmetry (see Section 5.50).

5.97 Show that for a transversely isotropic elastic material with \mathbf{e}_3 as the axis of transverse isotropy (see Section 5.50).

$$(\sin \beta)^2 C_{1111} + [(\cos \beta)^2 - (\sin \beta)^2] C_{1122} + 2[(\cos \beta)^2 - (\sin \beta)^2] C_{1212} - (\cos \beta)^2 C_{2222} = 0.$$

5.98 In Section 5.50, we obtained the reduction in the elastic coefficients for a transversely isotropic elastic solid by demanding that each S_β plane is a plane of material symmetry. We can also obtain the same reduction by demanding that the C'_{ijkl} be the same for all β . Use this procedure to obtain the result: $C_{1133} = C_{2233}$.

5.99 Invert the compliance matrix for a transversely isotropic elastic solid to obtain the relationship between C_{ij} and the engineering constants. That is, verify Eqs. (5.53.2) and (5.53.3) by inverting the following matrix:

$$[A] = \begin{bmatrix} 1/E_1 & -\nu_{21}/E_1 & -\nu_{31}/E_3 \\ -\nu_{21}/E_1 & 1/E_1 & -\nu_{31}/E_3 \\ -\nu_{13}/E_1 & -\nu_{13}/E_1 & 1/E_3 \end{bmatrix}.$$

5.100 Obtain Eq. (5.53.6) from Eqs. (5.53.2) and (5.53.3).

5.101 Invert the compliance matrix for an orthotropic elastic solid to obtain the relationship between C_{ij} and the engineering constants.

- 5.102 Obtain the restriction given in Eq. (5.54.8) for engineering constants for an orthotropic elastic solid.
- 5.103 Write down all the restrictions for the engineering constants for a monoclinic solid in determinant form (no need to expand the determinants).

PART C: ISOTROPIC ELASTIC SOLID UNDER LARGE DEFORMATION

5.56 CHANGE OF FRAME

In classical mechanics, an observer is defined as a rigid body with a clock. In the theory of continuum mechanics, an observer is often referred to as a *frame*. One then speaks of “a change of frame” to mean the transformation between the pair $\{\mathbf{x}, t\}$ in one frame to the pair $\{\mathbf{x}^*, t^*\}$ of a different frame, where \mathbf{x} is the position vector of a material point as observed by the unstarred frame, \mathbf{x}^* is that observed by the starred frame, and t is time, which, in classical mechanics, may be taken to be the same (or differ by a constant) for the two frames. Since the two frames are rigid bodies, the most general change of frame is given by [see Eq. (3.6.4)]

$$\mathbf{x}^* = \mathbf{c}(t) + \mathbf{Q}(t)(\mathbf{x} - \mathbf{x}_0), \quad (5.56.1)$$

where $\mathbf{c}(t)$ represents the relative displacement of the base point \mathbf{x}_0 , $\mathbf{Q}(t)$ is a time-dependent orthogonal tensor, representing a rotation and possibly a reflection. The reflection is included to allow for the observers to use different-handed coordinate systems. If one assumes that all observers use the same handed system, the general orthogonal tensor $\mathbf{Q}(t)$ in the preceding equation can be replaced by a proper orthogonal tensor.

It is important to note that a change of frame is different from a change of coordinate system. Each frame can perform any number of coordinate transformations within itself, whereas a transformation between two frames is given by Eq. (5.56.1).

The distance between two material points is called a *frame-indifference scalar* (or *objective scalar*) because it is the same for any two observers. On the other hand, the speed of a material point obviously depends on the observers as the observers in general move relative to each other. The speed is therefore not frame-independent (nonobjective). We see, therefore, that though a scalar is by definition coordinate-invariant, it is not necessarily *frame-independent* (or *frame-invariant*).

The position vector and the velocity vector of a material point are obviously dependent on the observers. They are examples of vectors that are not frame indifferent. On the other hand, the vector connecting two material points and the relative velocity of two material points are examples of frame-indifferent vectors.

Let the position vector of two material points be $\mathbf{x}_1, \mathbf{x}_2$ in the unstarred frame and $\mathbf{x}_1^*, \mathbf{x}_2^*$ in the starred frame; then we have, from Eq. (5.56.1),

$$\mathbf{x}_1^* = \mathbf{c}(t) + \mathbf{Q}(t)(\mathbf{x}_1 - \mathbf{x}_0), \quad \mathbf{x}_2^* = \mathbf{c}(t) + \mathbf{Q}(t)(\mathbf{x}_2 - \mathbf{x}_0). \quad (5.56.2)$$

Thus,

$$\mathbf{x}_1^* - \mathbf{x}_2^* = \mathbf{Q}(t)(\mathbf{x}_1 - \mathbf{x}_2), \quad (5.56.3)$$

or

$$\mathbf{b}^* = \mathbf{Q}(t)\mathbf{b}, \quad (5.56.4)$$

where \mathbf{b}^* and \mathbf{b} denote the same vector connecting the two material points. Vectors obeying Eq. (5.56.4) in a change of frame given by Eq. (5.56.1) are called *objective* (or *indifferent*) vectors.

Let \mathbf{T} be a tensor that transforms a frame-indifferent vector \mathbf{b} into a frame-indifferent vector \mathbf{c} , i.e.,

$$\mathbf{c} = \mathbf{T}\mathbf{b} \quad (5.56.5)$$

and let \mathbf{T}^* be the same tensor as observed by the starred frame, then

$$\mathbf{c}^* = \mathbf{T}^*\mathbf{b}^*. \quad (5.56.6)$$

Since \mathbf{b} and \mathbf{c} are objective vectors, $\mathbf{c}^* = \mathbf{Q}\mathbf{c}$ and $\mathbf{b}^* = \mathbf{Q}\mathbf{b}$, so that

$$\mathbf{c}^* = \mathbf{Q}\mathbf{c} = \mathbf{Q}\mathbf{T}\mathbf{b} = \mathbf{Q}\mathbf{T}\mathbf{Q}^T\mathbf{b}^*. \quad (5.56.7)$$

That is, $\mathbf{T}^*\mathbf{b}^* = \mathbf{Q}\mathbf{T}\mathbf{Q}^T\mathbf{b}^*$. Since this is to be true for all \mathbf{b}^* , we have

$$\mathbf{T}^* = \mathbf{Q}\mathbf{T}\mathbf{Q}^T. \quad (5.56.8)$$

Tensors obeying Eq. (5.56.8) in a change of frame [described by Eq. (5.56.1)] are called *objective tensors*.

In summary, objective (or frame-indifferent) scalars, vectors, and tensors are those that obey the following transformation law in a change of frame $\mathbf{x}^* = \mathbf{c}(t) + \mathbf{Q}(t)(\mathbf{x} - \mathbf{x}_0)$:

Objective scalar: $\alpha^* = \alpha$

Objective vector: $\mathbf{b}^* = \mathbf{Q}(t)\mathbf{b}$

Objective tensor: $\mathbf{T}^* = \mathbf{Q}(t)\mathbf{T}\mathbf{Q}^T(t)$

Example 5.56.1

Show that (a) $d\mathbf{x}$ is an objective vector and (b) $ds \equiv |d\mathbf{x}|$ is an objective scalar.

Solution

(a) From Eq. (5.56.1), $\mathbf{x}^* = \mathbf{c}(t) + \mathbf{Q}(t)(\mathbf{x} - \mathbf{x}_0)$, we have

$$\mathbf{x}^* + d\mathbf{x}^* = \mathbf{c}(t) + \mathbf{Q}(t)(\mathbf{x} + d\mathbf{x} - \mathbf{x}_0), \quad (5.56.9)$$

therefore,

$$d\mathbf{x}^* = \mathbf{Q}(t)d\mathbf{x}, \quad (5.56.10)$$

so that $d\mathbf{x}$ is an objective vector.

(b) From Eq. (5.56.10)

$$(ds^*)^2 = d\mathbf{x}^* \cdot d\mathbf{x}^* = \mathbf{Q}(t)d\mathbf{x} \cdot \mathbf{Q}(t)d\mathbf{x} = d\mathbf{x} \cdot \mathbf{Q}^T\mathbf{Q}d\mathbf{x} = d\mathbf{x} \cdot d\mathbf{x} = (ds)^2. \quad (5.56.11)$$

That is, $ds^* = ds$ so that ds is an objective scalar.

Example 5.56.2

Show that in a change of frame, (a) the velocity vector \mathbf{v} transforms in accordance with the following equation and is therefore nonobjective:

$$\mathbf{v}^* = \mathbf{Q}(t)\mathbf{v} + \dot{\mathbf{Q}}(t)(\mathbf{x} - \mathbf{x}_0) + \dot{\mathbf{c}}(t), \quad (5.56.12)$$

and (b) the velocity gradient transforms in accordance with the following equation and is also nonobjective:

$$\nabla^* \mathbf{v}^* = \mathbf{Q}(t)(\nabla \mathbf{v})\mathbf{Q}^\top(t) + \dot{\mathbf{Q}}\mathbf{Q}^\top. \quad (5.56.13)$$

Solution

(a) From Eq. (5.56.1)

$$\frac{d\mathbf{x}^*}{dt} = \dot{\mathbf{c}}(t) + \dot{\mathbf{Q}}(t)(\mathbf{x} - \mathbf{x}_0) + \mathbf{Q}(t)\mathbf{v}. \quad (5.56.14)$$

That is,

$$\mathbf{v}^* = \mathbf{Q}(t)\mathbf{v} + \dot{\mathbf{c}}(t) + \dot{\mathbf{Q}}(t)(\mathbf{x} - \mathbf{x}_0). \quad (5.56.15)$$

This is not the transformation law for an objective vector; therefore, the velocity vector is nonobjective.

(b) From Eq. (5.56.15), we have

$$\mathbf{v}^*(\mathbf{x}^* + d\mathbf{x}^*, t) = \mathbf{Q}(t)\mathbf{v}(\mathbf{x} + d\mathbf{x}, t) + \dot{\mathbf{c}}(t) + \dot{\mathbf{Q}}(t)(\mathbf{x} + d\mathbf{x} - \mathbf{x}_0), \quad (5.56.16)$$

and

$$\mathbf{v}^*(\mathbf{x}^*, t) = \mathbf{Q}(t)\mathbf{v}(\mathbf{x}, t) + \dot{\mathbf{c}}(t) + \dot{\mathbf{Q}}(t)(\mathbf{x} - \mathbf{x}_0). \quad (5.56.17)$$

Subtraction of the preceding two equations gives

$$(\nabla^* \mathbf{v}^*)d\mathbf{x}^* = \mathbf{Q}(t)(\nabla \mathbf{v})d\mathbf{x} + \dot{\mathbf{Q}}(t)d\mathbf{x}. \quad (5.56.18)$$

But $d\mathbf{x}^* = \mathbf{Q}(t)d\mathbf{x}$; therefore,

$$\left[(\nabla^* \mathbf{v}^*)\mathbf{Q}(t) - \mathbf{Q}(t)(\nabla \mathbf{v}) - \dot{\mathbf{Q}}(t) \right] d\mathbf{x} = \mathbf{0}. \quad (5.56.19)$$

Thus,

$$\nabla^* \mathbf{v}^* = \mathbf{Q}(\nabla \mathbf{v})\mathbf{Q}^\top + \dot{\mathbf{Q}}\mathbf{Q}^\top. \quad (5.56.20)$$

Example 5.56.3

Show that in a change of frame, the deformation gradient \mathbf{F} transforms according to the equation

$$\mathbf{F}^* = \mathbf{Q}(t)\mathbf{F}. \quad (5.56.21)$$

Solution

We have, for the starred frame,

$$d\mathbf{x}^* = \mathbf{F}^* d\mathbf{X}^*, \quad (5.56.22)$$

and for the unstarred frame,

$$d\mathbf{x} = \mathbf{F}d\mathbf{X}. \quad (5.56.23)$$

In a change of frame, $d\mathbf{x}$ and $d\mathbf{x}^*$ are related by Eq. (5.56.10), that is, $d\mathbf{x}^* = \mathbf{Q}(t)d\mathbf{x}$, thus,

$$\mathbf{Q}(t)d\mathbf{x} = \mathbf{F}^* d\mathbf{X}^* \quad (5.56.24)$$

Using Eq. (5.56.23), we have

$$\mathbf{Q}(t)\mathbf{F}d\mathbf{X} = \mathbf{F}^*d\mathbf{X}^*. \quad (5.56.25)$$

Now, both $d\mathbf{X}$ and $d\mathbf{X}^*$ denote the same material element at the fixed reference time t_0 ; therefore, without loss of generality, we can take $\mathbf{Q}(t_0) = \mathbf{I}$, so that $d\mathbf{X} = d\mathbf{X}^*$, and we arrive at Eq. (5.56.21).

Example 5.56.4

Derive the transformation law for (a) the right Cauchy-Green deformation tensor and (b) the left Cauchy-Green deformation tensor.

Solution

(a) The right Cauchy-Green tensor \mathbf{C} is related to the deformation gradient \mathbf{F} by

$$\mathbf{C} = \mathbf{F}^T\mathbf{F}. \quad (5.56.26)$$

Thus, from the results of the last example,

$$\mathbf{C}^* = (\mathbf{F}^*)^T\mathbf{F}^* = (\mathbf{Q}\mathbf{F})^T\mathbf{Q}\mathbf{F} = \mathbf{F}^T\mathbf{Q}^T\mathbf{Q}\mathbf{F} = \mathbf{F}^T\mathbf{F}. \quad (5.56.27)$$

That is,

$$\mathbf{C}^* = \mathbf{C}. \quad (5.56.28)$$

Equation (5.56.28) states that the right Cauchy-Green tensor \mathbf{C} is nonobjective.

(b) The left Cauchy-Green tensor \mathbf{B} is related to the deformation gradient \mathbf{F} by

$$\mathbf{B} = \mathbf{F}\mathbf{F}^T. \quad (5.56.29)$$

Thus,

$$\mathbf{B}^* = \mathbf{F}^*\mathbf{F}^{*T} = \mathbf{Q}\mathbf{F}(\mathbf{Q}\mathbf{F})^T = \mathbf{Q}\mathbf{F}\mathbf{F}^T\mathbf{Q}^T. \quad (5.56.30)$$

That is,

$$\mathbf{B}^* = \mathbf{Q}(t)\mathbf{B}\mathbf{Q}(t)^T. \quad (5.56.31)$$

Equation (5.56.31) states that the left Cauchy-Green tensor is objective (frame-independent).

We note that it can be easily proved that the inverse of an objective tensor is also objective (see Prob. 5.104) and that the identity tensor is obviously objective. Thus, both the left Cauchy-Green deformation tensor \mathbf{B} and the Eulerian strain tensor $\mathbf{e} = (\mathbf{I} - \mathbf{B}^{-1})/2$ are objective, whereas the right Cauchy-Green deformation tensor \mathbf{C} and the Lagrangian strain tensor $\mathbf{E} = (\mathbf{C} - \mathbf{I})/2$ are nonobjective.

It can be shown (see Prob. 5.107) that in a change of frame, the material derivative of an objective tensor \mathbf{T} transforms in accordance with the equation

$$\dot{\mathbf{T}}^* = \dot{\mathbf{Q}}\mathbf{T}\mathbf{Q}^T(t) + \mathbf{Q}(t)\dot{\mathbf{T}}\mathbf{Q}^T(t) + \mathbf{Q}(t)\mathbf{T}\dot{\mathbf{Q}}^T. \quad (5.56.32)$$

Thus, the material time derivative of an objective tensor is, in general, nonobjective.

5.57 CONSTITUTIVE EQUATION FOR AN ELASTIC MEDIUM UNDER LARGE DEFORMATION

As in the case of the infinitesimal theory of an elastic body, the constitutive equation relates the state of stress to the state of deformation. However, in the case of finite deformation, there are different finite deformation tensors (left Cauchy-Green tensor \mathbf{B} , right Cauchy-Green tensor \mathbf{C} , Lagrangian strain tensor \mathbf{E} , etc.) and different stress tensors (Cauchy stress tensors and the two Piola-Kirchhoff stress tensors) defined in Chapters 3 and 4, respectively. It is not immediately clear what stress tensor is to be related to what deformation tensor. For example, if one assumes that $\mathbf{T} = \mathbf{T}(\mathbf{C})$, where \mathbf{T} is Cauchy stress tensor and \mathbf{C} is the right Cauchy-Green tensor, then it can be shown (see Example 5.57.2) that this is not an acceptable form of constitutive equation, because the law will not be frame-indifferent. On the other hand, if one assumes $\mathbf{T} = \mathbf{T}(\mathbf{B})$, then this law is acceptable in that it is independent of observers, but it is limited to isotropic material only (see Example 5.57.4).

The requirement that a constitutive equation must be invariant under the transformation Eq. (5.56.1) (i.e., in a change of frame), is known as the *principle of material indifference*. In applying this principle, we shall insist that force and, therefore, the Cauchy stress tensor be frame-indifferent. That is, in a change of frame,

$$\mathbf{T}^* = \mathbf{Q}\mathbf{T}\mathbf{Q}^T. \quad (5.57.1)$$

Example 5.57.1

Show that (a) in a change of frame, the first Piola-Kirchhoff stress tensor, defined by $\mathbf{T}_0 \equiv J\mathbf{T}(\mathbf{F}^{-1})^T$, $J = |\det \mathbf{F}|$, transforms in accordance with the equation

$$\mathbf{T}_0^* \equiv \mathbf{Q}(t)\mathbf{T}_0. \quad (5.57.2)$$

(b) In a change of frame, the second Piola-Kirchhoff stress tensor, defined by $\tilde{\mathbf{T}} = J\mathbf{F}^{-1}\mathbf{T}(\mathbf{F}^{-1})^T$, transforms in accordance with the equation

$$\tilde{\mathbf{T}}^* = \tilde{\mathbf{T}}. \quad (5.57.3)$$

Solution

(a) From Eq. (5.56.21), we have, in a change of frame, $\mathbf{F}^* = \mathbf{Q}(t)\mathbf{F}$. Thus,

$$J^* = |\det \mathbf{F}^*| = |\det [\mathbf{Q}(t)\mathbf{F}]| = |[\det \mathbf{Q}(t)][\det \mathbf{F}]| = J. \quad (5.57.4)$$

Also, $\mathbf{T}^* = \mathbf{Q}\mathbf{T}\mathbf{Q}^T$; thus,

$$\begin{aligned} \mathbf{T}_0^* &\equiv J^*\mathbf{T}^*(\mathbf{F}^{*-1})^T = J\mathbf{Q}\mathbf{T}\mathbf{Q}^T[(\mathbf{Q}\mathbf{F})^{-1}]^T = J\mathbf{Q}\mathbf{T}\mathbf{Q}^T(\mathbf{F}^{-1}\mathbf{Q}^T)^T \\ &= J\mathbf{Q}\mathbf{T}\mathbf{Q}^T\mathbf{Q}(\mathbf{F}^{-1})^T = J\mathbf{Q}\mathbf{T}(\mathbf{F}^{-1})^T = \mathbf{Q}J\mathbf{T}(\mathbf{F}^{-1})^T = \mathbf{Q}\mathbf{T}_0. \end{aligned}$$

(b) The derivation is similar to (a) (see Prob. 5.110).

Example 5.57.2

Assume that for some elastic medium, the Cauchy stress \mathbf{T} is proportional to the right Cauchy-Green tensor \mathbf{C} . Show that this assumption does not result in a frame-indifferent constitutive equation and is therefore not acceptable.

Solution

The assumption states that for the starred frame,

$$\mathbf{T}^* = \alpha \mathbf{C}^*, \quad (5.57.5)$$

and for the unstarred frame,

$$\mathbf{T} = \alpha \mathbf{C}, \quad (5.57.6)$$

where we note that since the *same* material is considered by the two frames, the proportional constant must be the same. Now, from Eqs. (5.57.1) and (5.56.28), we have

$$\mathbf{T}^* = \mathbf{Q}\mathbf{T}\mathbf{Q}^T \quad \text{and} \quad \mathbf{C}^* = \mathbf{C},$$

thus Eq. (5.57.5) becomes

$$\mathbf{Q}\mathbf{T}\mathbf{Q}^T = \alpha \mathbf{C} = \mathbf{T}. \quad (5.57.7)$$

The only \mathbf{T} for the preceding equation to be true is $\mathbf{T} = \alpha \mathbf{I}$. Thus, Eq. (5.57.6) is not an acceptable constitutive equation.

More generally, if we assume that the Cauchy stress is a function of the right Cauchy-Green tensor, then for the starred frame $\mathbf{T}^* = \mathbf{f}(\mathbf{C}^*)$ and for the unstarred frame $\mathbf{T} = \mathbf{f}(\mathbf{C})$, where \mathbf{f} is the *same* function for both frames because it is for the *same* material. Again, in a change of frame, $\mathbf{Q}\mathbf{T}\mathbf{Q}^T = \mathbf{f}(\mathbf{C}) = \mathbf{T}$. That is, again, $\mathbf{T} = \mathbf{f}(\mathbf{C})$ is not acceptable.

Example 5.57.3

Assume that the second Piola-Kirchhoff stress tensor $\tilde{\mathbf{T}}$ is a function of the right Cauchy-Green deformation tensor \mathbf{C} . Show that it is an acceptable constitutive equation.

Solution

We have, according to the assumption,

$$\tilde{\mathbf{T}} = \mathbf{f}(\mathbf{C}), \quad (5.57.8)$$

and

$$\tilde{\mathbf{T}}^* = \mathbf{f}(\mathbf{C}^*), \quad (5.57.9)$$

where we demand that both frames (the starred and the unstarred) have the same function \mathbf{f} for the same material. Now, in a change of frame, the second Piola-Kirchhoff stress tensor, $\tilde{\mathbf{T}} = |(\det \mathbf{F})| \mathbf{F}^{-1} \mathbf{T} (\mathbf{F}^{-1})^T$, is transformed as [see Eq. (5.57.3) and Prob. 5.110]:

$$\tilde{\mathbf{T}}^* = \tilde{\mathbf{T}}. \quad (5.57.10)$$

Therefore, in a change of frame, the equation $\tilde{\mathbf{T}}^* = \mathbf{f}(\mathbf{C}^*)$ does transform into $\tilde{\mathbf{T}} = \mathbf{f}(\mathbf{C})$, which shows that the assumption is acceptable. In fact, it can be shown that Eq. (5.57.8) is the most general constitutive equation for an anisotropic elastic solid (see Prob. 5.111).

Example 5.57.4

Show that $\mathbf{T} = \mathbf{f}(\mathbf{B})$, where \mathbf{T} is the Cauchy stress tensor and \mathbf{B} is the left Cauchy-Green deformation tensor, is an acceptable constitutive law for an isotropic elastic solid.

Solution

For the starred frame

$$\mathbf{T}^* = \mathbf{f}(\mathbf{B}^*), \quad (5.57.11)$$

and for the unstarred frame,

$$\mathbf{T} = \mathbf{f}(\mathbf{B}), \quad (5.57.12)$$

where both frames have the same function \mathbf{f} . In a change of frame, from Eqs. (5.57.1) and (5.56.31), we have

$$\mathbf{T}^* = \mathbf{Q}\mathbf{T}\mathbf{Q}^T \quad \text{and} \quad \mathbf{B}^* = \mathbf{Q}\mathbf{B}\mathbf{Q}^T. \quad (5.57.13)$$

Thus,

$$\mathbf{Q}\mathbf{T}\mathbf{Q}^T = \mathbf{f}(\mathbf{Q}\mathbf{B}\mathbf{Q}^T). \quad (5.57.14)$$

That is, in order that the equation $\mathbf{T} = \mathbf{f}(\mathbf{B})$ be acceptable as a constitutive law, it must satisfy the condition given by the preceding equation, Eq. (5.57.14). In matrix form, Eqs. (5.57.12) and (5.57.14) are $[\mathbf{T}] = [\mathbf{f}(\mathbf{B})]$ and $[\mathbf{Q}][\mathbf{T}][\mathbf{Q}]^T = [\mathbf{f}(\mathbf{Q}[\mathbf{B}][\mathbf{Q}]^T)]$, respectively. Now if we view these two matrix equations as those corresponding to changes of rectangular Cartesian bases, then we come to the conclusion that the constitutive equation, given by Eq. (5.57.12), describes an *isotropic* material because both matrix equations have the same function \mathbf{f} for any $[\mathbf{Q}]$. We note that Eq. (5.57.14) can also be written as

$$\mathbf{Q}\mathbf{f}(\mathbf{B})\mathbf{Q}^T = \mathbf{f}(\mathbf{Q}\mathbf{B}\mathbf{Q}^T). \quad (5.57.15)$$

A function \mathbf{f} satisfying the preceding equation is known as an *isotropic function*.

A special case of the preceding constitutive equation is given by

$$\mathbf{T} = \alpha\mathbf{B}, \quad (5.57.16)$$

where α is a constant. Eq. (5.57.16) describes a so-called *Hookean solid*.

5.58 CONSTITUTIVE EQUATION FOR AN ISOTROPIC ELASTIC MEDIUM

From the examples in the last section, we see that the assumption that $\mathbf{T} = \mathbf{f}(\mathbf{B})$, where \mathbf{T} is the Cauchy stress and \mathbf{B} is the left Cauchy-Green deformation tensor, leads to the constitutive equation for an isotropic elastic medium under large deformation and the function $\mathbf{f}(\mathbf{B})$ is an isotropic function satisfying the condition [Eq. (5.57.15)].

It can be proved that in three-dimensional space, the most general isotropic function can be represented by the following equation (see Appendix 5C.1):

$$\mathbf{f}(\mathbf{B}) = a_0\mathbf{I} + a_1\mathbf{B} + a_2\mathbf{B}^2, \quad (5.58.1)$$

where a_0 , a_1 and a_2 are scalar functions of the principal scalar invariants of the tensor \mathbf{B} , so that the general constitutive equation for an isotropic elastic solid under large deformation is given by

$$\mathbf{T} = a_0\mathbf{I} + a_1\mathbf{B} + a_2\mathbf{B}^2. \quad (5.58.2)$$

Since a tensor satisfies its own characteristic equation (see Example 5.58.1), we have

$$\mathbf{B}^3 - I_1 \mathbf{B}^2 + I_2 \mathbf{B} - I_3 \mathbf{I} = 0, \quad (5.58.3)$$

where I_1 , I_2 and I_3 are the principal scalar invariants of the tensor \mathbf{B} . From Eq. (5.58.3), we have

$$\mathbf{B}^2 = I_1 \mathbf{B} - I_2 \mathbf{I} + I_3 \mathbf{B}^{-1}. \quad (5.58.4)$$

Substituting Eq. (5.58.4) into Eq. (5.58.2), we obtain

$$\mathbf{T} = \varphi_0 \mathbf{I} + \varphi_1 \mathbf{B} + \varphi_2 \mathbf{B}^{-1}, \quad (5.58.5)$$

where φ_0 , φ_1 and φ_2 are scalar functions of the principal scalar invariants of the tensor \mathbf{B} . This is the alternate form of the constitutive equation for an isotropic elastic solid under large deformations.

Example 5.58.1

Derive the Cayley-Hamilton Theorem, Eq. (5.58.3).

Solution

Since \mathbf{B} is real and symmetric, there always exist three eigenvalues corresponding to three mutually perpendicular eigenvector directions (see Section 2.23). The eigenvalue λ_i satisfies the characteristic equation:

$$\lambda_i^3 - I_1 \lambda_i^2 + I_2 \lambda_i - I_3 = 0, \quad i = 1, 2, 3. \quad (5.58.6)$$

The preceding three equations can be written in a matrix form as

$$\begin{bmatrix} \lambda_1 & 0 & 0 \\ 0 & \lambda_2 & 0 \\ 0 & 0 & \lambda_3 \end{bmatrix}^3 - I_1 \begin{bmatrix} \lambda_1 & 0 & 0 \\ 0 & \lambda_2 & 0 \\ 0 & 0 & \lambda_3 \end{bmatrix}^2 + I_2 \begin{bmatrix} \lambda_1 & 0 & 0 \\ 0 & \lambda_2 & 0 \\ 0 & 0 & \lambda_3 \end{bmatrix} - I_3 \begin{bmatrix} 1 & 0 & 0 \\ 0 & 1 & 0 \\ 0 & 0 & 1 \end{bmatrix} = \begin{bmatrix} 0 & 0 & 0 \\ 0 & 0 & 0 \\ 0 & 0 & 0 \end{bmatrix}. \quad (5.58.7)$$

Now the matrix

$$\begin{bmatrix} \lambda_1 & 0 & 0 \\ 0 & \lambda_2 & 0 \\ 0 & 0 & \lambda_3 \end{bmatrix}$$

is the matrix for the tensor \mathbf{B} using its eigenvectors as the Cartesian rectangular basis. Thus, Eq. (5.58.7) has the following invariant form given by Eq. (5.58.3), i.e.,

$$\mathbf{B}^3 - I_1 \mathbf{B}^2 + I_2 \mathbf{B} - I_3 \mathbf{I} = 0.$$

Equation (5.58.2), or equivalently, Eq. (5.58.5), is the most general constitutive equation for an isotropic elastic solid under large deformation.

If the material is incompressible, then the constitutive equation is indeterminate to an arbitrary hydrostatic pressure and the constitutive equation becomes

$$\mathbf{T} = -p \mathbf{I} + \varphi_1 \mathbf{B} + \varphi_2 \mathbf{B}^{-1}, \quad (5.58.8)$$

where φ_1 and φ_2 are functions of the principal scalar invariants of \mathbf{B} , I_1 , and I_2 ($I_3 = 1$ for an incompressible solid). If the functions φ_1 and φ_2 are derived from a potential function A of I_1 and I_2 , such that

$$\varphi_1 = 2\rho \frac{\partial A}{\partial I_1} \quad \text{and} \quad \varphi_2 = -2\rho \frac{\partial A}{\partial I_2}, \quad (5.58.9)$$

then

$$\mathbf{T} = -p\mathbf{I} + 2\rho \frac{\partial A}{\partial I_1} \mathbf{B} - 2\rho \frac{\partial A}{\partial I_2} \mathbf{B}^{-1}. \quad (5.58.10)$$

Such a solid is known as an incompressible *hyperelastic isotropic solid*. A well-known constitutive equation for such a solid is given by the following:

$$\mathbf{T} = -p\mathbf{I} + \mu \left(\frac{1}{2} + \beta \right) \mathbf{B} - \mu \left(\frac{1}{2} - \beta \right) \mathbf{B}^{-1}, \quad (5.58.11)$$

where $\mu > 0$, $-1/2 \leq \beta \leq 1/2$. This constitutive equation defines the Mooney-Rivlin theory for rubber (see Encyclopedia of Physics, ed. S. Flugge, Vol. III/3, Springer-Verlag, 1965, p. 349). The strain energy function corresponding to this constitutive equation is given by

$$\rho A(\mathbf{B}) = \frac{1}{2} \mu \left[\left(\frac{1}{2} + \beta \right) (I_1 - 3) + \left(\frac{1}{2} - \beta \right) (I_2 - 3) \right] \quad (5.58.12)$$

5.59 SIMPLE EXTENSION OF AN INCOMPRESSIBLE ISOTROPIC ELASTIC SOLID

A rectangular bar of an incompressible isotropic elastic solid is pulled in the x_1 direction. At equilibrium, the ratio of the deformed length to the undeformed length (the stretch) is λ_1 in the x_1 direction and λ_2 in the transverse direction. Thus, the equilibrium configuration is given by

$$x_1 = \lambda_1 x_1, \quad x_2 = \lambda_2 x_2, \quad x_3 = \lambda_2 x_3, \quad \lambda_1 \lambda_2^2 = 1, \quad (5.59.1)$$

where the condition $\lambda_1 \lambda_2^2 = 1$ describes the *isochoric* condition (i.e., no change in volume).

The matrices of the left Cauchy-Green deformation tensor and its inverse are given by

$$[\mathbf{B}] = \begin{bmatrix} \lambda_1^2 & 0 & 0 \\ 0 & \lambda_2^2 & 0 \\ 0 & 0 & \lambda_2^2 \end{bmatrix}, \quad [\mathbf{B}]^{-1} = \begin{bmatrix} 1/\lambda_1^2 & 0 & 0 \\ 0 & 1/\lambda_2^2 & 0 \\ 0 & 0 & 1/\lambda_2^2 \end{bmatrix}. \quad (5.59.2)$$

From the constitutive equation $\mathbf{T} = -p\mathbf{I} + \varphi_1 \mathbf{B} + \varphi_2 \mathbf{B}^{-1}$, the nonzero stress components are obtained to be

$$T_{11} = -p + \varphi_1 \lambda_1^2 + \varphi_2 / \lambda_1^2, \quad T_{22} = T_{33} = -p + \varphi_1 \lambda_2^2 + \varphi_2 / \lambda_2^2. \quad (5.59.3)$$

Since these stress components are constants, the equations of equilibrium in the absence of body forces are clearly satisfied. Also, from the boundary conditions that on the faces $x_2 = \pm b$, $T_{22} = 0$ and on the faces $x_3 = \pm c$, $T_{33} = 0$, we obtain that everywhere in the rectangular bar,

$$T_{22} = T_{33} = 0. \quad (5.59.4)$$

Thus, from Eq. (5.59.3), since $\lambda_1 \lambda_2^2 = 1$, we have

$$p = \varphi_1 \lambda_2^2 + \varphi_2 / \lambda_2^2 = \varphi_1 / \lambda_1 + \varphi_2 \lambda_1. \quad (5.59.5)$$

Therefore, the normal stress T_{11} , needed to stretch the incompressible bar (which is laterally unconfined) in the x_1 direction for an amount given by the stretch λ_1 , is given by

$$T_{11} = (\lambda_1^2 - 1/\lambda_1) \varphi_1 + (1/\lambda_1^2 - \lambda_1) \varphi_2 = (\lambda_1^2 - 1/\lambda_1) (\varphi_1 - \varphi_2 / \lambda_1). \quad (5.59.6)$$

5.60 SIMPLE SHEAR OF AN INCOMPRESSIBLE ISOTROPIC ELASTIC RECTANGULAR BLOCK

The state of simple shear deformation is defined by the following equations relating the spatial coordinates x_i to the material coordinates X_i :

$$x_1 = X_1 + KX_2, \quad x_2 = X_2, \quad x_3 = X_3.$$

The deformed configuration of the rectangular block is shown in plane view in Figure 5.60-1, where one sees that the constant K is the amount of shear. The left Cauchy-Green tensor and its inverse are given by

$$[\mathbf{B}] = [\mathbf{FF}^T] = \begin{bmatrix} 1 & K & 0 \\ 0 & 1 & 0 \\ 0 & 0 & 1 \end{bmatrix} \begin{bmatrix} 1 & 0 & 0 \\ K & 1 & 0 \\ 0 & 0 & 1 \end{bmatrix} = \begin{bmatrix} 1+K^2 & K & 0 \\ K & 1 & 0 \\ 0 & 0 & 1 \end{bmatrix}. \quad (5.60.1)$$

$$[\mathbf{B}]^{-1} = \begin{bmatrix} 1 & -K & 0 \\ -K & 1+K^2 & 0 \\ 0 & 0 & 1 \end{bmatrix}. \quad (5.60.2)$$

The principal scalar invariants are

$$I_1 = 3 + K^2, \quad I_2 = 3 + K^2, \quad I_3 = 1. \quad (5.60.3)$$

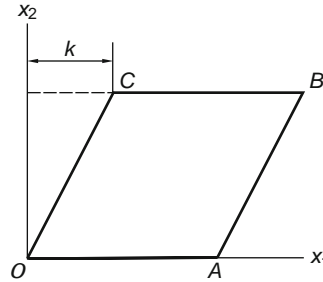

FIGURE 5.60-1

Thus, from Eq. (5.58.8),

$$\begin{aligned} T_{11} &= -p + (1 + K^2)\varphi_1 + \varphi_2, & T_{22} &= -p + \varphi_1 + (1 + K^2)\varphi_2, & T_{33} &= -p + \varphi_1 + \varphi_2, \\ T_{12} &= K(\varphi_1 - \varphi_2), & T_{13} &= T_{23} = 0. \end{aligned} \quad (5.60.4)$$

Let

$$-P \equiv -p + \varphi_1 + \varphi_2, \quad (5.60.5)$$

then

$$\begin{aligned} T_{11} &= -P + \varphi_1 K^2, & T_{22} &= -P + \varphi_2 K^2, & T_{33} &= -P, & T_{12} &= K(\varphi_1 - \varphi_2), \\ T_{13} &= T_{23} = 0, \end{aligned} \quad (5.60.6)$$

where φ_1 and φ_2 are functions of K^2 .

The stress components are constants; therefore, the equations of equilibrium in the absence of body forces are clearly satisfied. If the boundary $X_3 = x_3 = \text{constant}$ plane is free of stress, then $P = 0$ so that

$$T_{11} = \varphi_1 K^2, \quad T_{22} = \varphi_2 K^2, \quad T_{33} = 0, \quad T_{12} = K(\varphi_1 - \varphi_2), \quad T_{13} = T_{23} = 0, \quad (5.60.7)$$

where $(\varphi_1 - \varphi_2)$ is sometimes called the *generalized shear modulus* in the particular undistorted state used as the reference. It is an even function of K , the amount of shear. The surface traction needed to maintain this simple shear state of deformation is as follows.

On the top face in Figure 5.60-1, there is a normal stress, $T_{22} = \varphi_2 K^2$, and a shear stress, $T_{12} = K(\varphi_1 - \varphi_2)$. On the bottom face, there is an equal and opposite surface traction to that on the top face. On the right face, which, at equilibrium, is no longer perpendicular to the x_1 -axis but has a unit normal given by

$$\mathbf{n} = \frac{\mathbf{e}_1 - K\mathbf{e}_2}{\sqrt{1 + K^2}}, \quad (5.60.8)$$

therefore, the surface traction on this deformed plane is given by

$$\begin{aligned} [\mathbf{t}] &= [\mathbf{T}][\mathbf{n}] = \frac{1}{\sqrt{1 + K^2}} \begin{bmatrix} \varphi_1 K^2 & K(\varphi_1 - \varphi_2) \\ K(\varphi_1 - \varphi_2) & \varphi_2 K^2 \end{bmatrix} \begin{bmatrix} 1 \\ -K \end{bmatrix} \\ &= \frac{K}{\sqrt{1 + K^2}} \begin{bmatrix} \varphi_2 K \\ \varphi_1 - (1 + K^2)\varphi_2 \end{bmatrix}. \end{aligned} \quad (5.60.9)$$

Thus, the normal stress on this plane is

$$T_n = \mathbf{t} \cdot \mathbf{n} = -\frac{K^2}{1 + K^2} [\varphi_1 - (2 + K^2)\varphi_2], \quad (5.60.10)$$

and the shear stress on this plane is, with unit tangent vector given by,

$$\mathbf{e}_t = \frac{K\mathbf{e}_1 + \mathbf{e}_2}{\sqrt{1 + K^2}}, \quad (5.60.11)$$

$$T_s = \mathbf{t} \cdot \mathbf{e}_t = \frac{K}{1 + K^2} (\varphi_1 - \varphi_2). \quad (5.60.12)$$

We see from the preceding equations that in addition to shear stresses, normal stresses are needed to maintain the simple shear state of deformation. We also note that

$$T_{11} - T_{22} = KT_{12}. \quad (5.60.13)$$

This is a universal relation, independent of the coefficients φ_i of the material.

5.61 BENDING OF AN INCOMPRESSIBLE ISOTROPIC RECTANGULAR BAR

It is easy to verify that the deformation of a rectangular bar into a curved bar as shown in Figure 5.61-1 can be described by the following equations:

$$r = (2\alpha X + \beta)^{1/2}, \quad \theta = cY, \quad z = Z, \quad \alpha = 1/c,$$

where (X, Y, Z) are Cartesian material coordinates and (r, θ, z) are cylindrical spatial coordinates. Indeed, the boundary planes $X = \mp a$ deform into cylindrical surfaces $r = \sqrt{\mp 2\alpha a + \beta}$ and the boundary planes $Y = \pm b$ deform into the planes $\theta = \pm cb$.

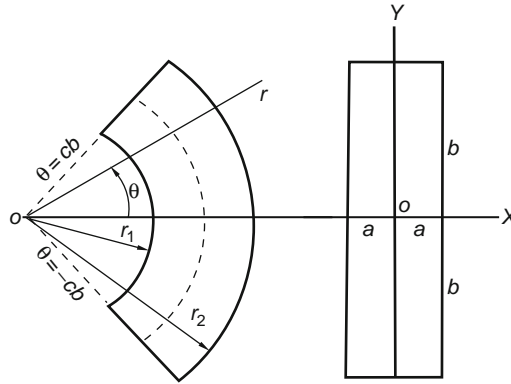

FIGURE 5.61-1

The left Cauchy-Green tensor \mathbf{B} corresponding to this deformation field can be calculated using Eqs. (3.29.59) to Eq. (3.29.64) in Chapter 3 (see Prob. 5.112):

$$[\mathbf{B}] = \begin{bmatrix} \alpha^2/r^2 & 0 & 0 \\ 0 & c^2 r^2 & 0 \\ 0 & 0 & 1 \end{bmatrix} = \begin{bmatrix} \alpha^2/r^2 & 0 & 0 \\ 0 & r^2/\alpha^2 & 0 \\ 0 & 0 & 1 \end{bmatrix}. \quad (5.61.1)$$

The inverse of \mathbf{B} can be obtained to be

$$[\mathbf{B}^{-1}] = \begin{bmatrix} r^2/\alpha^2 & 0 & 0 \\ 0 & 1/(c^2 r^2) & 0 \\ 0 & 0 & 1 \end{bmatrix} = \begin{bmatrix} r^2/\alpha^2 & 0 & 0 \\ 0 & \alpha^2/r^2 & 0 \\ 0 & 0 & 1 \end{bmatrix}. \quad (5.61.2)$$

The principal scalar invariants of \mathbf{B} are

$$I_1 = \frac{\alpha^2}{r^2} + \frac{r^2}{\alpha^2} + 1 = I_2, \quad I_3 = \alpha^2 c^2 = 1. \quad (5.61.3)$$

We shall use the constitutive equation for a hyperelastic solid for this problem. From Eq. (5.58.10), with A replacing ρA since ρ is a constant, we have

$$T_{rr} = -p + 2 \frac{\partial A}{\partial I_1} \frac{\alpha^2}{r^2} - 2 \frac{\partial A}{\partial I_2} \frac{r^2}{\alpha^2}, \quad T_{\theta\theta} = -p + 2 \frac{\partial A}{\partial I_1} \frac{r^2}{\alpha^2} - 2 \frac{\partial A}{\partial I_2} \frac{\alpha^2}{r^2}, \quad (5.61.4)$$

$$T_{zz} = -p + 2 \frac{\partial A}{\partial I_1} - 2 \frac{\partial A}{\partial I_2}, \quad T_{r\theta} = T_{rz} = T_{\theta z} = 0, \quad (5.61.5)$$

where the function $A = A(I_1, I_2)$ is a function of r alone.

The equations of equilibrium in the absence of body forces are [see Eqs. (4.8.1) to (4.8.3)]

$$\frac{\partial T_{rr}}{\partial r} + \frac{T_{rr} - T_{\theta\theta}}{r} = 0, \quad \frac{\partial T_{\theta\theta}}{\partial \theta} = 0, \quad \frac{\partial T_{zz}}{\partial z} = 0. \quad (5.61.6)$$

From the second equation in Eq. (5.61.4) and the second equation in Eq. (5.61.6), we have $\partial p / \partial \theta = 0$. Also, the first equation in Eq. (5.61.5) and the third equation in Eq. (5.61.6) give $\partial p / \partial z = 0$. Thus,

$$p = p(r). \quad (5.61.7)$$

Now it is a simple matter to verify that

$$\frac{dA}{dr} = \frac{\partial A}{\partial I_1} \frac{dI_1}{dr} + \frac{\partial A}{\partial I_2} \frac{dI_2}{dr} = \left(-\frac{2\alpha^2}{r^3} + \frac{2r}{\alpha^2} \right) \left(\frac{\partial A}{\partial I_1} + \frac{\partial A}{\partial I_2} \right) = -\frac{T_{rr} - T_{\theta\theta}}{r}, \quad (6.61.8)$$

therefore, the r equation of equilibrium becomes

$$\frac{dT_{rr}}{dr} - \frac{dA}{dr} = 0, \quad (5.61.9)$$

so that

$$T_{rr} = A(r) + K. \quad (5.61.10)$$

Using the preceding equation and the r equation of equilibrium again, we have

$$T_{\theta\theta} = r \frac{dT_{rr}}{dr} + T_{rr} = \frac{d(rT_{rr})}{dr} = \frac{d(rA)}{dr} + K. \quad (5.61.11)$$

The boundary conditions are

$$T_{rr}(r_1) = T_{rr}(r_2) = 0. \quad (5.61.12)$$

Thus,

$$A(r_1) + K = 0 \quad \text{and} \quad A(r_2) + K = 0, \quad (5.61.13)$$

from which we have

$$A(r_1) = A(r_2). \quad (5.61.14)$$

Recalling that

$$A = A(I_1, I_2) \quad \text{where} \quad I_1 = I_2 = \frac{\alpha^2}{r^2} + \frac{r^2}{\alpha^2} + 1, \quad (5.61.15)$$

we have

$$\frac{\alpha^2}{r_1^2} + \frac{r_1^2}{\alpha^2} + 1 = \frac{\alpha^2}{r_2^2} + \frac{r_2^2}{\alpha^2} + 1, \quad (5.61.16)$$

from which we can obtain

$$\alpha^2 = r_1 r_2. \quad (5.61.15)$$

For given values of r_1 and r_2 , Eq. (5.61.16) allows us to obtain α and β from the equations $r_1 = \sqrt{-2\alpha a + \beta}$ and $r_2 = \sqrt{2\alpha a + \beta}$ so that $a = (r_2^2 - r_1^2)/(4\alpha)$ and $\beta = (r_1^2 + r_2^2)/2$.

Using Eq. (5.61.11), the normal force per unit width (in z direction) on the end planes $\theta = \pm cb$ in the deformed state is given by

$$\int_{r_1}^{r_2} T_{\theta\theta} dr = \int_{r_1}^{r_2} \left(\frac{d(rA)}{dr} + K \right) dr = [r\{A(r) + K\}]_{r_1}^{r_2} = 0, \quad (5.61.17)$$

where we have used the boundary conditions Eqs. (5.61.13). Thus, on these end planes, there are no net resultant forces, only equal and opposite couples. Let M denote the flexural couple per unit width, then

$$\begin{aligned} M &= \int_{r_1}^{r_2} r T_{\theta\theta} dr = \int_{r_1}^{r_2} \left(r \frac{d(rA)}{dr} + Kr \right) dr = [r^2 A(r)]_{r_1}^{r_2} - \int_{r_1}^{r_2} r A(r) dr + \left[\frac{Kr^2}{2} \right]_{r_1}^{r_2} \\ &= r_2^2 A(r_2) - r_1^2 A(r_1) - \int_{r_1}^{r_2} r A(r) dr + \frac{Kr_2^2}{2} - \frac{Kr_1^2}{2}. \end{aligned} \quad (5.61.18)$$

That is,

$$M = \frac{K}{2} (r_1^2 - r_2^2) - \int_{r_1}^{r_2} rA(r)dr. \quad (5.61.19)$$

In arriving at the preceding equation, we used Eqs. (5.61.13).

5.62 TORSION AND TENSION OF AN INCOMPRESSIBLE ISOTROPIC SOLID CYLINDER

Consider the following equilibrium configuration for a circular cylinder:

$$r = \lambda_1 R, \quad \theta = \Theta + KZ, \quad z = \lambda_3 Z, \quad \lambda_1^2 \lambda_3 = 1, \quad (5.62.1)$$

where (r, θ, z) are the spatial coordinates and (R, Θ, Z) are the material coordinates for a material point, and λ_1 and λ_3 are stretches for elements that were in the radial and axial direction, respectively. The equation $\lambda_1^2 \lambda_3 = 1$ indicates that there is no change in volume [see I_3 in Eq. (5.62.3)].

The left Cauchy-Green deformation tensor \mathbf{B} and its inverse can be obtained from Eq. (3.29.19) to Eq. (3.29.24) (note: $r_0 \equiv R$, $\theta_0 \equiv \Theta$, $z_0 \equiv Z$ in those equations) as (see Prob. 5.113)

$$\mathbf{B} = \begin{bmatrix} \lambda_1^2 & 0 & 0 \\ 0 & \lambda_1^2 + r^2 K^2 & rK\lambda_3 \\ 0 & rK\lambda_3 & \lambda_3^2 \end{bmatrix}, \quad \mathbf{B}^{-1} = \begin{bmatrix} 1/\lambda_1^2 & 0 & 0 \\ 0 & 1/\lambda_1^2 & -Kr \\ 0 & -Kr & \lambda_1^4 + \lambda_1^2 r^2 K^2 \end{bmatrix}. \quad (5.62.2)$$

The principal scalar invariants of \mathbf{B} are (note: $\lambda_1^2 \lambda_3 = 1$):

$$I_1 = \frac{2}{\lambda_3} + r^2 K^2 + \lambda_3^2, \quad I_2 = 2\lambda_3 + \frac{1}{\lambda_3^2} (1 + \lambda_3 r^2 K^2), \quad I_3 = \lambda_1^4 \lambda_3^2 = 1. \quad (5.62.3)$$

Since I_i 's are functions of r only, φ_i 's are functions of r only.

Now, from the constitutive equation $\mathbf{T} = -p\mathbf{I} + \varphi_1\mathbf{B} + \varphi_2\mathbf{B}^{-1}$, we have

$$T_{rr} = -p + \varphi_1 \lambda_1^2 + \frac{\varphi_2}{\lambda_1^2} = -p + \frac{\varphi_1}{\lambda_3} + \varphi_2 \lambda_3, \quad (5.62.4)$$

$$T_{\theta\theta} = -p + \varphi_1 (\lambda_1^2 + r^2 K^2) + \frac{\varphi_2}{\lambda_1^2} = -p + \varphi_1 \left(\frac{1}{\lambda_3} + r^2 K^2 \right) + \varphi_2 \lambda_3, \quad (5.62.5)$$

$$T_{zz} = -p + \varphi_1 \lambda_3^2 + \varphi_2 \lambda_1^2 (\lambda_1^2 + r^2 K^2) = -p + \varphi_1 \lambda_3^2 + \frac{\varphi_2}{\lambda_3} \left(\frac{1}{\lambda_3} + r^2 K^2 \right), \quad (5.62.6)$$

$$T_{\theta z} = K\lambda_3 r \left(\varphi_1 - \frac{\varphi_2}{\lambda_3} \right), \quad (5.62.7)$$

$$T_{rz} = T_{r\theta} = 0. \quad (5.62.8)$$

The equations of equilibrium in the absence of body forces are

$$\frac{\partial T_{rr}}{\partial r} + \frac{T_{rr} - T_{\theta\theta}}{r} = 0, \quad \frac{\partial T_{\theta\theta}}{\partial \theta} = 0, \quad \frac{\partial T_{zz}}{\partial z} = 0. \quad (5.62.9)$$

Thus, $\frac{\partial p}{\partial \theta} = \frac{\partial p}{\partial z} = 0$, so that

$$p = p(r). \quad (5.62.10)$$

From the r equation of equilibrium, we have

$$r \frac{dT_{rr}}{dr} = T_{\theta\theta} - T_{rr}. \quad (5.62.11)$$

The total normal force on a cross-section plane is given by

$$N = \int_0^{r_0} T_{zz} 2\pi r dr. \quad (5.62.12)$$

To evaluate the preceding integral, we first need to eliminate p from the equation for T_{zz} . This can be done in the following way.

Let

$$T_{zz} = -p + \tau_{zz}, \quad T_{rr} = -p + \tau_{rr}, \quad T_{\theta\theta} = -p + \tau_{\theta\theta}, \quad (5.62.13)$$

where

$$\tau_{rr} = \frac{\varphi_1}{\lambda_3} + \varphi_2 \lambda_3, \quad \tau_{\theta\theta} = \varphi_1 \left(\frac{1}{\lambda_3} + r^2 K^2 \right) + \varphi_2 \lambda_3, \quad \tau_{zz} = \varphi_1 \lambda_3^2 + \frac{\varphi_2}{\lambda_3} \left(\frac{1}{\lambda_3} + r^2 K^2 \right). \quad (5.62.14)$$

Then we have, from Eq. (5.62.13),

$$2T_{zz} = -2p + 2\tau_{zz} = (T_{rr} - \tau_{rr}) + (T_{\theta\theta} - \tau_{\theta\theta}) + 2\tau_{zz} = T_{rr} + T_{\theta\theta} - \tau_{rr} - \tau_{\theta\theta} + 2\tau_{zz}. \quad (5.62.15)$$

Using Eq. (5.62.11), we can write $T_{rr} + T_{\theta\theta} = 2T_{rr} + (T_{\theta\theta} - T_{rr}) = 2T_{rr} + r \frac{dT_{rr}}{dr} = \frac{1}{r} \frac{dr^2 T_{rr}}{dr}$; thus,

$$2T_{zz} = \frac{1}{r} \frac{d}{dr} (r^2 T_{rr}) - \tau_{rr} - \tau_{\theta\theta} + 2\tau_{zz}. \quad (5.62.16)$$

Substituting the preceding equation in Eq. (5.62.12), we have

$$N = \int_0^{r_0} 2T_{zz} \pi r dr = \pi \int_0^{r_0} \frac{d}{dr} (r^2 T_{rr}) dr + \pi \int_0^{r_0} (2\tau_{zz} - \tau_{rr} - \tau_{\theta\theta}) r dr. \quad (5.62.17)$$

Applying the boundary condition $T_{rr}(r_0) = 0$, the first integral in the right-hand side is zero; therefore,

$$N = \pi \int_0^{r_0} (2\tau_{zz} - \tau_{rr} - \tau_{\theta\theta}) r dr. \quad (5.62.18)$$

Now Eqs. (5.62.14) give

$$2\tau_{zz} - \tau_{rr} - \tau_{\theta\theta} = 2 \left(\lambda_3^2 - \frac{1}{\lambda_3} \right) \left(\varphi_1 - \frac{\varphi_2}{\lambda_3} \right) - \left(\varphi_1 - \frac{2\varphi_2}{\lambda_3} \right) r^2 K^2. \quad (5.62.19)$$

Thus,

$$N = 2\pi \left(\lambda_3^2 - \frac{1}{\lambda_3} \right) \int_0^{r_0} \left(\varphi_1 - \frac{\varphi_2}{\lambda_3} \right) r dr - \pi K^2 \int_0^{r_0} \left(\varphi_1 - \frac{2\varphi_2}{\lambda_3} \right) r^3 dr. \quad (5.62.20)$$

Since $r = \lambda_1 R$ and $\lambda_1^2 \lambda_3 = 1$ [see Eq. (5.62.1)], $r dr = \lambda_1^2 R dR = R dR / \lambda_3$; therefore,

$$N = 2\pi \left(\lambda_3 - \frac{1}{\lambda_3^2} \right) \int_0^{R_0} \left(\varphi_1 - \frac{\varphi_2}{\lambda_3} \right) R dR - \frac{\pi K^2}{\lambda_3^2} \int_0^{R_0} \left(\varphi_1 - \frac{2\varphi_2}{\lambda_3} \right) R^3 dR, \quad (5.62.21)$$

where $R_0 = r_0/\lambda_1$. Similarly, the twisting moment can be obtained to be

$$M = \int_0^{r_0} r T_{\theta z} 2\pi r dr = 2\pi K \lambda_3 \int_0^{r_0} r^3 \left(\varphi_1 - \frac{\varphi_2}{\lambda_3} \right) dr = \frac{2\pi K}{\lambda_3} \int_0^{R_0} \left(\varphi_1 - \frac{\varphi_2}{\lambda_3} \right) R^3 dR. \quad (5.62.22)$$

In the preceding equations for M and N , φ_1 and φ_2 are functions of I_1 and I_2 and are therefore functions of R .

If the angle of twist K is very small, then

$$I_1 \approx \frac{2}{\lambda_3} + \lambda_3^2, \quad I_2 \approx 2\lambda_3 + \frac{1}{\lambda_3^2}, \quad (5.62.23)$$

which are independent of R . As a consequence, φ_1 and φ_2 are independent of R , and the integrals in Eq. (5.62.21) and (5.62.22) can be integrated to give

$$N = \pi R_0^2 \left(\lambda_3 - \frac{1}{\lambda_3^2} \right) \left(\varphi_1 - \frac{\varphi_2}{\lambda_3} \right) + O(K^2), \quad (5.62.24)$$

and

$$M = \frac{K\pi R_0^4}{2\lambda_3} \left(\varphi_1 - \frac{\varphi_2}{\lambda_3} \right). \quad (5.62.25)$$

We see, therefore, that if the bar is prevented from extension or contraction (i.e., $\lambda_3 = 1$), then twisting of the bar with an angle of twisting K approaching zero gives rise to a small axial force N , which approaches zero with K^2 . On the other hand, if the bar is free from axial force (i.e., $N = 0$), then as K approaches zero, there is an axial stretch λ_3 such that $(\lambda_3 - 1)$ approaches zero with K^2 . Thus, when a circular bar is twisted with an infinitesimal angle of twist, the axial stretch is negligible, as was shown earlier in the infinitesimal theory.

From Eq. (5.62.24) and (5.62.25), we can obtain for $K \rightarrow 0$

$$\frac{M}{K} = \frac{R_0^2}{2} \frac{N}{(\lambda_3^2 - 1/\lambda_3)}. \quad (5.62.26)$$

Eq. (5.62.26) is known as *Rivlin's universal relation*. This equation gives, for a small twisting angle, the torsion stiffness as a function of λ_3 , the stretch in the axial direction. We see, therefore, that the torsion stiffness can be obtained from a simple-extension experiment that measures N as a function of the axial stretch λ_3 .

APPENDIX 5C.1: REPRESENTATION OF ISOTROPIC TENSOR-VALUED FUNCTIONS

Let $\mathbf{S} = \mathbf{F}(\mathbf{T})$ be such that for every orthogonal tensor \mathbf{Q} ,

$$\mathbf{Q}\mathbf{S}\mathbf{Q}^T = \mathbf{F}(\mathbf{Q}\mathbf{T}\mathbf{Q}^T). \quad (i)$$

The function $\mathbf{F}(\mathbf{T})$ is said to be an *isotropic function*. Here in this appendix, we show that the most general form of $\mathbf{F}(\mathbf{T})$ is

$$\mathbf{F}(\mathbf{T}) = a_0(I_i) + a_1(I_i)\mathbf{T} + a_2(I_i)\mathbf{T}^2, \quad (ii)$$

or

$$\mathbf{F}(\mathbf{T}) = f_0(I_i) + f_1(I_i)\mathbf{T} + f_2(I_i)\mathbf{T}^{-1}. \quad (iii)$$

We will prove the preceding statement in several steps:

1. First, we show that the principal directions of \mathbf{T} are also principal directions of \mathbf{S} :

Let \mathbf{e}_i be a principal direction of \mathbf{T} . Since \mathbf{T} is symmetric, the principal directions $\{\mathbf{e}_1, \mathbf{e}_2, \mathbf{e}_3\}$ form an orthonormal basis with respect to which the matrix of \mathbf{T} is diagonal. Let \mathbf{Q}_1 be a reflection about a plane normal to \mathbf{e}_1 , i.e., $\mathbf{Q}_1\mathbf{e}_1 = -\mathbf{e}_1$, then

$$[\mathbf{Q}_1] = \begin{bmatrix} -1 & 0 & 0 \\ 0 & 1 & 0 \\ 0 & 0 & 1 \end{bmatrix}_{\{\mathbf{e}_1, \mathbf{e}_2, \mathbf{e}_3\}}. \quad (\text{iv})$$

Thus,

$$[\mathbf{Q}_1][\mathbf{T}][\mathbf{Q}_1]^T = \begin{bmatrix} -1 & 0 & 0 \\ 0 & 1 & 0 \\ 0 & 0 & 1 \end{bmatrix} \begin{bmatrix} T_1 & 0 & 0 \\ 0 & T_2 & 0 \\ 0 & 0 & T_3 \end{bmatrix} \begin{bmatrix} -1 & 0 & 0 \\ 0 & 1 & 0 \\ 0 & 0 & 1 \end{bmatrix} = \begin{bmatrix} T_1 & 0 & 0 \\ 0 & T_2 & 0 \\ 0 & 0 & T_3 \end{bmatrix} = [\mathbf{T}]. \quad (\text{v})$$

That is, $\mathbf{Q}_1\mathbf{T}\mathbf{Q}_1^T = \mathbf{T}$. Now, by Eq. (i), $\mathbf{Q}_1\mathbf{S}\mathbf{Q}_1^T = \mathbf{F}(\mathbf{T}) = \mathbf{S}$, so that $\mathbf{Q}_1\mathbf{S} = \mathbf{S}\mathbf{Q}_1$. Therefore,

$$\mathbf{Q}_1\mathbf{S}\mathbf{e}_1 = \mathbf{S}\mathbf{Q}_1\mathbf{e}_1 = -\mathbf{S}\mathbf{e}_1. \quad (\text{vi})$$

The only vectors transformed by the reflection \mathbf{Q}_1 into their opposite are the multiples of \mathbf{e}_1 ; therefore, $\mathbf{S}\mathbf{e}_1 = \mu_1\mathbf{e}_1$. That is, \mathbf{e}_1 is a principal direction of \mathbf{S} . Clearly, then, every principal direction of \mathbf{T} is a principal direction of \mathbf{S} .

2. Next we show that for all orthogonal tensors \mathbf{Q} , $\mathbf{Q}\mathbf{T}\mathbf{Q}^T$ have the same set of eigenvalues as that of \mathbf{T} .

Let λ be an eigenvalue of \mathbf{T} . Then $\mathbf{T}\mathbf{n} = \lambda\mathbf{n}$, so that $(\mathbf{Q}\mathbf{T}\mathbf{Q}^T)(\mathbf{Q}\mathbf{n}) = \mathbf{Q}\mathbf{T}\mathbf{n} = \lambda(\mathbf{Q}\mathbf{n})$. Thus, λ is also an eigenvalue of $\mathbf{Q}\mathbf{T}\mathbf{Q}^T$. Also, if $(\mathbf{Q}\mathbf{T}\mathbf{Q}^T)\mathbf{m} = \lambda\mathbf{m}$, then $\mathbf{T}(\mathbf{Q}^T\mathbf{m}) = \lambda(\mathbf{Q}^T\mathbf{m})$. That is, if λ is an eigenvalue of $\mathbf{Q}\mathbf{T}\mathbf{Q}^T$, then it is also an eigenvalue for \mathbf{T} . Thus, all $\mathbf{Q}\mathbf{T}\mathbf{Q}^T$ have the same set of eigenvalues $(\lambda_1, \lambda_2, \lambda_3)$ of \mathbf{T} , and all $\mathbf{Q}\mathbf{S}\mathbf{Q}^T$ have the same set of eigenvalues (μ_1, μ_2, μ_3) of \mathbf{S} . Now $\mathbf{Q}\mathbf{S}\mathbf{Q}^T = \mathbf{F}(\mathbf{Q}\mathbf{T}\mathbf{Q}^T)$; therefore, the eigenvalues $(\lambda_1, \lambda_2, \lambda_3)$ completely determine (μ_1, μ_2, μ_3) . In other words,

$$\mu_1 = \hat{\mu}_1(\lambda_1, \lambda_2, \lambda_3), \quad \mu_2 = \hat{\mu}_2(\lambda_1, \lambda_2, \lambda_3), \quad \mu_3 = \hat{\mu}_3(\lambda_1, \lambda_2, \lambda_3). \quad (\text{vii})$$

3. If $(\lambda_1, \lambda_2, \lambda_3)$ are distinct, then one can always find

$$a_0(\lambda_1, \lambda_2, \lambda_3), \quad a_1(\lambda_1, \lambda_2, \lambda_3) \quad \text{and} \quad a_3(\lambda_1, \lambda_2, \lambda_3),$$

such that

$$\begin{aligned} \mu_1 &= a_0 + a_1\lambda_1 + a_2\lambda_1^2, \\ \mu_2 &= a_0 + a_1\lambda_2 + a_2\lambda_2^2, \\ \mu_3 &= a_0 + a_1\lambda_3 + a_2\lambda_3^2. \end{aligned} \quad (\text{viii})$$

because the determinant

$$\begin{vmatrix} 1 & \lambda_1 & \lambda_1^2 \\ 1 & \lambda_2 & \lambda_2^2 \\ 1 & \lambda_3 & \lambda_3^2 \end{vmatrix} = (\lambda_1 - \lambda_2)(\lambda_2 - \lambda_3)(\lambda_3 - \lambda_1) \neq 0. \quad (\text{ix})$$

4. Eq. (viii) can be written in matrix form as

$$\begin{bmatrix} \mu_1 & 0 & 0 \\ 0 & \mu_2 & 0 \\ 0 & 0 & \mu_3 \end{bmatrix} = a_0 \begin{bmatrix} 1 & 0 & 0 \\ 0 & 1 & 0 \\ 0 & 0 & 1 \end{bmatrix} + a_1 \begin{bmatrix} \lambda_1 & 0 & 0 \\ 0 & \lambda_2 & 0 \\ 0 & 0 & \lambda_3 \end{bmatrix} + a_2 \begin{bmatrix} \lambda_1^2 & 0 & 0 \\ 0 & \lambda_2^2 & 0 \\ 0 & 0 & \lambda_3^2 \end{bmatrix}. \quad (\text{x})$$

Now, since the eigenvectors of \mathbf{T} coincide with the eigenvectors of \mathbf{S} . Therefore, using the eigenvectors as an orthonormal basis, the preceding matrix equation becomes

$$\mathbf{S} = a_0(\lambda_i)\mathbf{I} + a_1(\lambda_i)\mathbf{T} + a_2(\lambda_i)\mathbf{T}^2. \quad (\text{xi})$$

In the preceding equation, the eigenvalues λ_i are determined from $\lambda^3 - I_1\lambda^2 + I_2\lambda - I_3 = 0$, the characteristic equation of \mathbf{T} , where $\{I_1, I_2, I_3\}$ are the principal scalar invariants of \mathbf{T} ; therefore, $\lambda_i = \lambda_i(I_1, I_2, I_3)$. Thus, Eq. (xi) can be written

$$\mathbf{S} = b_0(I_i)\mathbf{I} + b_1(I_i)\mathbf{T} + b_2(I_i)\mathbf{T}^2. \quad (\text{xii})$$

5. If the characteristic equation for the tensor \mathbf{T} has a repeated root $\lambda_2 = \lambda_3 \neq \lambda_1$, then the eigenvector corresponding λ_1 is also an eigenvector for \mathbf{S} with eigenvalue $\mu_1 = \hat{\mu}_1(\lambda_1, \lambda_2)$, and every eigenvector (infinitely many) for the repeated root λ_2 is also an eigenvector for \mathbf{S} , with one eigenvalue $\mu_2 = \hat{\mu}_2(\lambda_1, \lambda_2)$. Thus,

$$\mu_1 = a_0(\lambda_1, \lambda_2) + a_1(\lambda_1, \lambda_2)\lambda_1 \quad \text{and} \quad \mu_2 = a_0(\lambda_1, \lambda_2) + a_1(\lambda_1, \lambda_2)\lambda_2, \quad (\text{xiii})$$

and as a consequence,

$$\mathbf{S} = b_0(I_i)\mathbf{I} + b_1(I_i)\mathbf{T}. \quad (\text{xiv})$$

6. If $\lambda_1 = \lambda_2 = \lambda_3 = \lambda$, then every direction is an eigenvector for \mathbf{T} with eigenvalue λ ; therefore, every direction is an eigenvector for \mathbf{S} with eigenvalue μ . Thus, $\mu = a_0(\lambda)$, a function of λ . As a consequence,

$$\mathbf{S} = f_0(I_i)\mathbf{I}. \quad (\text{xv})$$

PROBLEMS FOR PART C

5.104 Show that if a tensor is objective, then its inverse is also objective.

5.105 Show that the rate of deformation tensor $\mathbf{D} = [\nabla\mathbf{v} + (\nabla\mathbf{v})^T]/2$ is objective. (See Example 5.56.2.)

5.106 Show that in a change of frame, the spin tensor $\mathbf{W} = [\nabla\mathbf{v} - (\nabla\mathbf{v})^T]/2$ transforms in accordance with the equation $\mathbf{W}^* = \mathbf{Q}(t)\mathbf{W}\mathbf{Q}^T(t) + \dot{\mathbf{Q}}\mathbf{Q}^T$. (See Example 5.56.2.)

5.107 Show that in a change of frame, the material derivative of an objective tensor \mathbf{T} transforms in accordance with the equation $\dot{\mathbf{T}}^* = \dot{\mathbf{Q}}\mathbf{T}\mathbf{Q}^T(t) + \mathbf{Q}(t)\dot{\mathbf{T}}\mathbf{Q}^T(t) + \mathbf{Q}(t)\mathbf{T}\dot{\mathbf{Q}}^T$, where a super-dot indicates material derivative. Thus the material derivative of an objective tensor \mathbf{T} is nonobjective.

5.108 The second Rivlin-Ericksen tensor is defined by $\mathbf{A}_2 = \dot{\mathbf{A}}_1 + \mathbf{A}_1(\nabla\mathbf{v}) + (\nabla\mathbf{v})^T\mathbf{A}_1$, where $\dot{\mathbf{A}}_1 \equiv D\mathbf{A}_1/D\mathbf{T}$ and $\mathbf{A}_1 = 2\mathbf{D} = \nabla\mathbf{v} + (\nabla\mathbf{v})^T$. Show that \mathbf{A}_2 is objective. (See Prob. 5.105 and Example 5.56.2.)

- 5.109** The Jaumann derivative of a second-order objective tensor \mathbf{T} is $\dot{\mathbf{T}} + \mathbf{T}\mathbf{W} - \mathbf{W}\mathbf{T}$, where \mathbf{W} is the spin tensor. Show that the Jaumann derivative of \mathbf{T} is objective. (See Prob. 5.106 and Prob. 5.107.)
- 5.110** The second Piola-Kirchhoff stress tensor $\tilde{\mathbf{T}}$ is related to the first Piola-Kirchhoff stress tensor \mathbf{T}_0 by the formula $\tilde{\mathbf{T}} = \mathbf{F}^{-1}\mathbf{T}_0$, or to the Cauchy stress tensor \mathbf{T} by $\tilde{\mathbf{T}} = (\det \mathbf{F})\mathbf{F}^{-1}\mathbf{T}(\mathbf{F}^{-1})^T$. Show that, in a change of frame, $\tilde{\mathbf{T}}^* = \tilde{\mathbf{T}}$. (See Example 5.56.3 and Example 5.57.1.)
- 5.111** Starting from the constitutive assumption that $\mathbf{T} = \mathbf{H}(\mathbf{F})$ and $\mathbf{T}^* = \mathbf{H}(\mathbf{F}^*)$, where \mathbf{T} is Cauchy stress and \mathbf{F} is deformation gradient, show that in order that the assumption be independent of observers, $\mathbf{H}(\mathbf{F})$ must transform in accordance with the equation $\mathbf{Q}\mathbf{T}\mathbf{Q}^T = \mathbf{H}(\mathbf{Q}\mathbf{F})$. Choose $\mathbf{Q} = \mathbf{R}^T$ to obtain $\mathbf{T} = \mathbf{R}\mathbf{H}(\mathbf{U})\mathbf{R}^T$, where \mathbf{R} is the rotation tensor associated with \mathbf{F} and \mathbf{U} is the right stretch tensor. Show that $\tilde{\mathbf{T}} = \mathbf{h}(\mathbf{U})$, where $\mathbf{h} = (\det \mathbf{U})\mathbf{U}^{-1}\mathbf{H}(\mathbf{U})\mathbf{U}^{-1}$. $\mathbf{C} = \mathbf{U}^2$; therefore, we may write $\mathbf{T} = \mathbf{f}(\mathbf{C})$.
- 5.112** From $r = (2\alpha x + \beta)^{1/2}$, $\theta = cY$, $z = Z$, where $\alpha = 1/c$, obtain the right Cauchy-Green deformation tensor \mathbf{B} . *Hint:* Use formulas given in Chapter 3.
- 5.113** From $r = \lambda_1 R$, $\theta = \Theta + KZ$, $z = \lambda_3 Z$, where $\lambda_1^2 \lambda_3 = 1$, obtain the right Cauchy-Green deformation tensor \mathbf{B} . *Hint:* Use formulas given in Section 3.29, Chapter 3.

Newtonian Viscous Fluid

Substances such as water and air are examples of *fluids*. Mechanically speaking, they are different from a piece of steel or concrete in that they are unable to sustain shearing stresses without continuously deforming. For example, if water or air is placed between two parallel plates with, say, one of the plates fixed and the other plate applying a shearing stress, it will deform indefinitely with time if the shearing stress is not removed. Also, in the presence of gravity, the fact that water at rest always conforms to the shape of its container is a demonstration of its inability to sustain shearing stress at rest.

Based on this notion of fluidity, we define a fluid to be a class of idealized materials which, when in rigid body motion (including the state of rest), cannot sustain any shearing stress. Water is also an example of a fluid that is referred to as a liquid which undergoes negligible density changes under a wide range of loads, whereas air is a fluid that is referred to as a gas which does otherwise. This aspect of behavior is generalized into the concept of *incompressible* and *compressible* fluids. However, under certain conditions (low Mach number flow), air can be treated as incompressible, and under other conditions (e.g., the propagation of the acoustic waves), water has to be treated as compressible.

In this chapter, we study a special model of fluid which has the property that the stress associated with the motion depends linearly on the instantaneous value of the rate of deformation. This model of fluid is known as a *Newtonian fluid* or *linearly viscous fluid*, which has been found to describe adequately the mechanical behavior of many real fluids under a wide range of situations. However, some fluids, such as polymeric solutions, require a more general model (*non-Newtonian fluids*) for an adequate description. Non-Newtonian fluid models are discussed in Chapter 8.

6.1 FLUIDS

Based on the notion of fluidity discussed in the previous paragraphs, we define a *fluid* to be a class of idealized materials that, when in rigid body motions (including the state of rest), cannot sustain any shearing stresses. In other words, when a fluid is in a rigid body motion, the stress vector on *any* plane at any point is normal to the plane. That is, for any \mathbf{n} ,

$$\mathbf{T}\mathbf{n} = \lambda\mathbf{n}. \quad (6.1.1)$$

It is easy to show from Eq. (6.1.1) that the magnitude of the stress vector λ is the same for every plane passing through a given point. In fact, let \mathbf{n}_1 and \mathbf{n}_2 be normal vectors to any two such planes; then we have

$$\mathbf{T}\mathbf{n}_1 = \lambda_1\mathbf{n}_1 \quad \text{and} \quad \mathbf{T}\mathbf{n}_2 = \lambda_2\mathbf{n}_2. \quad (6.1.2)$$

Thus,

$$\mathbf{n}_1 \cdot \mathbf{T}\mathbf{n}_2 - \mathbf{n}_2 \cdot \mathbf{T}\mathbf{n}_1 = (\lambda_2 - \lambda_1) \mathbf{n}_1 \cdot \mathbf{n}_2. \quad (6.1.3)$$

Since $\mathbf{n}_2 \cdot \mathbf{T}\mathbf{n}_1 = \mathbf{n}_1 \cdot \mathbf{T}^T\mathbf{n}_2$ and \mathbf{T} is symmetric ($\mathbf{T} = \mathbf{T}^T$), the left side of Eq. (6.1.3) is zero. Thus,

$$(\lambda_2 - \lambda_1) \mathbf{n}_1 \cdot \mathbf{n}_2 = 0. \quad (6.1.4)$$

Since \mathbf{n}_1 and \mathbf{n}_2 are any two vectors,

$$\lambda_1 = \lambda_2. \quad (6.1.5)$$

In other words, on all planes passing through a point, not only are there no shearing stresses, but also the normal stresses are all the same. We shall denote this normal stress by $-p$. Thus,

$$\mathbf{T} = -p\mathbf{I}. \quad (6.1.6)$$

Or, in component form,

$$T_{ij} = -p\delta_{ij}. \quad (6.1.7)$$

The scalar p is the magnitude of the compressive normal stress and is known as the *hydrostatic pressure*.

6.2 COMPRESSIBLE AND INCOMPRESSIBLE FLUIDS

What one generally calls a “liquid” such as water or mercury has the property that its density essentially remains unchanged under a wide range of pressures. Idealizing this property, we define an incompressible fluid to be one for which the density of every particle remains the same at all times, regardless of the state of stress. That is, for an incompressible fluid,

$$\frac{D\rho}{Dt} = 0. \quad (6.2.1)$$

It then follows from the equation of conservation of mass, Eq. (3.15.3),

$$\frac{D\rho}{Dt} + \rho \frac{\partial v_k}{\partial x_k} = 0, \quad (6.2.2)$$

that for an incompressible fluid,

$$\frac{\partial v_k}{\partial x_k} = 0, \quad (6.2.3)$$

or

$$\operatorname{div} \mathbf{v} = 0. \quad (6.2.4)$$

All incompressible fluids need not have a spatially uniform density (e.g., salt water with nonuniform salt concentration with depth may be modeled as a nonhomogeneous fluid). If the density is also uniform, it is referred to as a *homogeneous fluid*, for which ρ is constant everywhere.

Substances such as air and vapors that change their density appreciably with pressure are often treated as compressible fluids. Of course, it is not hard to see that there are situations in which water has to be regarded as compressible and air may be regarded as incompressible. However, for theoretical studies, it is convenient to regard the incompressible and compressible fluids as two distinct kinds of fluids.

6.3 EQUATIONS OF HYDROSTATICS

The equations of equilibrium in terms of stresses are [see Eq. (4.7.6)]

$$\frac{\partial T_{ij}}{\partial x_j} + \rho B_i = 0, \quad (6.3.1)$$

where B_i are components of body forces per unit mass. With

$$T_{ij} = -p\delta_{ij}, \quad (6.3.2)$$

Eq. (6.3.1) becomes

$$\frac{\partial p}{\partial x_i} = \rho B_i, \quad (6.3.3)$$

or

$$\nabla p = \rho \mathbf{B}. \quad (6.3.4)$$

In the case where B_i are components of the weight per unit mass, if we let the positive x_3 -axis point vertically downward, we have

$$B_1 = 0, \quad B_2 = 0, \quad B_3 = g, \quad (6.3.5)$$

so that

$$\frac{\partial p}{\partial x_1} = 0, \quad \frac{\partial p}{\partial x_2} = 0, \quad \frac{\partial p}{\partial x_3} = \rho g. \quad (6.3.6)$$

Equations (6.3.6) state that p is a function of x_3 alone, and the pressure difference between any two points, say, point 2 and point 1 in the liquid, is simply

$$p_2 - p_1 = \rho gh, \quad (6.3.7)$$

where h is the depth of point 2 relative to point 1. Thus, the static pressure in the liquid depends only on the depth. It is the same for all particles that are on the same horizontal plane within the same liquid.

If the fluid is in a state of rigid body motion (rate of deformation = 0), then T_{ij} is still given by Eq. (6.3.2), but the right-hand side of Eq. (6.3.1) is equal to ρa_i , where a_i are the acceleration components of the fluid, which moves like a rigid body, so that the governing equation is now given by

$$-\frac{\partial p}{\partial x_i} + \rho B_i = \rho a_i. \quad (6.3.8)$$

Example 6.3.1

A cylindrical body of radius r , length ℓ , and weight W is tied by a rope to the bottom of a container that is filled with a liquid of density ρ . If the density of the body ρ_B is less than that of the liquid, find the tension in the rope (Figure 6.3-1).

Solution

Let p_u and p_b be the pressure at the upper and the bottom surfaces of the cylinder, respectively. Let T be the tension in the rope. Then the equilibrium of the cylindrical body requires that

$$\rho_b(\pi r^2) - p_u(\pi r^2) - W - T = 0.$$

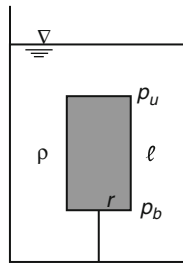

FIGURE 6.3-1

That is,

$$T = \pi r^2(p_b - p_u) - W.$$

Now, from Eq. (6.3.7),

$$(p_b - p_u) = \rho g \ell,$$

therefore,

$$T = \pi r^2 \rho g \ell - W = \pi r^2 \ell g (\rho - \rho_B).$$

We note that $\pi r^2 \ell \rho g$ is the buoyancy force which is equal to the weight of the liquid displaced by the body.

Example 6.3.2

A tank containing a homogeneous fluid moves horizontally to the right with a constant acceleration a (Figure 6.3-2). (a) Find the angle θ of the inclination of the free surface and (b) find the pressure at any point P inside the fluid.

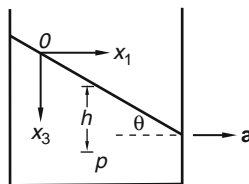

FIGURE 6.3-2

Solution

(a) With $a_1 = a$, $a_2 = a_3 = 0$, $B_1 = B_2 = 0$, and $B_3 = g$, the equations of motion, Eq. (6.3.8) becomes

$$\rho a = -\frac{\partial p}{\partial x_1}, \quad 0 = -\frac{\partial p}{\partial x_2}, \quad 0 = -\frac{\partial p}{\partial x_3} + \rho g. \quad (i)$$

Integration of the preceding equations give

$$p = -\rho a x_1 + \rho g x_3 + c. \quad (ii)$$

To determine the integration constant c , we note that on any point on the free surface, the pressure is equal to the ambient pressure p_0 . Let the origin of the coordinate axes (fixed respect to the earth) be location at a point on the free surface at the instant of interest; then

$$c = p_0. \quad (\text{iii})$$

Thus, the pressure inside the fluid at any point (x_1, x_2, x_3) is given by

$$p = -\rho ax_1 + \rho gx_3 + p_0. \quad (\text{iv})$$

To find the equation for the free surface where the pressure is p_0 , we substitute $p = p_0$ in Eq. (iv) and obtain

$$x_3 = \frac{a}{g} x_1. \quad (\text{v})$$

Thus, the free surface is a plane with an angle of inclination given by

$$\tan \theta = \frac{dx_3}{dx_1} = \frac{a}{g}. \quad (\text{vi})$$

(b) Referring to Figure 6.3-2, we have $(x_3 - h)/x_1 = \tan \theta$; thus,

$$x_3 = x_1(a/g) + h,$$

therefore,

$$p = -\rho ax_1 + \rho g \left(h + \frac{x_1 a}{g} \right) + p_0 = \rho gh + p_0, \quad (\text{vii})$$

i.e., the pressure at any point inside the fluid depends only on the depth h of that point from the free surface directly above it and the pressure at the free surface.

6.4 NEWTONIAN FLUIDS

When a shear stress is applied to an elastic solid, it deforms from its initial configuration and reaches an equilibrium state with a nonzero shear deformation; the deformation will disappear when the shear stress is removed. When a shear stress is applied to a layer of fluid (such as water, alcohol, mercury, or air), it will deform from its initial configuration and eventually reach a steady state where the fluid continuously deforms with a nonzero rate of shear, as long as the shear stress is applied. When the shear stress is removed, the fluid will simply remain at the deformed state obtained prior to the removal of the shear stress. Thus, the state of shear stress for a fluid in shearing motion is independent of shear deformation but is dependent on the rate of shear. For such fluids, no shear stress is needed to maintain a given amount of shear deformation, but a definite amount of shear stress is needed to maintain a constant rate of shear deformation.

Since the state of stress for a fluid under rigid body motion (including rest) is given by an isotropic tensor, in dealing with a fluid in general motion it is natural to decompose the stress tensor into two parts:

$$T_{ij} = -p\delta_{ij} + T'_{ij}, \quad (6.4.1)$$

where T'_{ij} depend only on the rate of deformation in such a way that they are zero when the fluid is under rigid body motion or rest (i.e., zero rate of deformation) and p is a scalar whose value is not to depend explicitly on the rate of deformation.

We now define a class of idealized materials called *Newtonian fluids* as follows:

1. For every material point, the values T'_{ij} at any time t depend linearly on the components of the rate of deformation tensor D_{ij} at that time and not on any other kinematical quantities (such as higher rates of deformation). The rate of deformation is related to the velocity gradient by

$$D_{ij} = \frac{1}{2} \left(\frac{\partial v_i}{\partial x_j} + \frac{\partial v_j}{\partial x_i} \right). \quad (6.4.2)$$

2. The fluid is isotropic with respect to any reference configuration.

Following the same arguments made in connection with the isotropic linear elastic material, we obtain that for a Newtonian fluid (also known as a *linearly viscous fluid*) the most general form of T'_{ij} is, with $\Delta \equiv D_{11} + D_{22} + D_{33} = D_{kk}$,

$$T'_{ij} = \lambda \Delta \delta_{ij} + 2\mu D_{ij}. \quad (6.4.3)$$

where λ and μ are material constants (different from those of an elastic body) having the dimension of (Force)(time)/(length)². The stress tensor T'_{ij} is known as the *viscous stress tensor*. Thus, the total stress tensor is

$$T_{ij} = -p\delta_{ij} + \lambda \Delta \delta_{ij} + 2\mu D_{ij}, \quad (6.4.4)$$

i.e.,

$$T_{11} = -p + \lambda \Delta + 2\mu D_{11}, \quad T_{22} = -p + \lambda \Delta + 2\mu D_{22}, \quad T_{33} = -p + \lambda \Delta + 2\mu D_{33}, \quad (6.4.5)$$

and

$$T_{12} = 2\mu D_{12}, \quad T_{13} = 2\mu D_{13}, \quad T_{23} = 2\mu D_{23}. \quad (6.4.6)$$

The scalar p in the preceding equation is called the *pressure*. As shown in Eqs. (6.4.5), the pressure p is in general not the total compressive normal stress on a plane. As a fluid theory, it is only necessary to remember that the isotropic tensor ($-p\delta_{ij}$) is that part of T_{ij} that does not depend explicitly on the rate of deformation.

6.5 INTERPRETATION OF λ AND μ

Consider the shear flow given by the velocity field

$$v_1 = v_1(x_2), \quad v_2 = 0, \quad v_3 = 0. \quad (6.5.1)$$

For this flow,

$$D_{11} = D_{22} = D_{33} = D_{13} = D_{23} = 0 \quad \text{and} \quad D_{12} = \frac{1}{2} \frac{dv_1}{dx_2} \quad (6.5.2)$$

so that

$$T_{11} = T_{22} = T_{33} = -p, \quad T_{13} = T_{23} = 0 \quad (6.5.3)$$

and

$$T_{12} = \mu \frac{dv_1}{dx_2}. \quad (6.5.4)$$

Thus, μ is the proportionality constant relating the shearing stress to the rate of decrease of the angle between two mutually perpendicular material lines Δx_1 and Δx_2 (see Section 3.13). It is called the *first coefficient of viscosity*, or simply *viscosity*.

From Eq. (6.4.3), we have, for a general velocity field,

$$\frac{1}{3}T'_{ii} = \left(\lambda + \frac{2\mu}{3} \right) \Delta, \quad (6.5.5)$$

where $\Delta = D_{ii}$ is the rate of change of volume (or rate of dilatation). Thus $(\lambda + \frac{2\mu}{3})$ is the proportionality constant relating the viscous mean normal stress ($T'_{ii}/3$) to the rate of change of volume Δ . It is known as the *second coefficient of viscosity*, or the *bulk viscosity*.

The mean normal stress is given by

$$\frac{1}{3}T_{ii} = -p + \left(\lambda + \frac{2\mu}{3} \right) \Delta. \quad (6.5.6)$$

We see that in general, p is not the mean normal stress unless either Δ is zero (e.g., in flows of an incompressible fluid) or the bulk viscosity $(\lambda + 2\mu/3)$ is zero. The assumption that the bulk viscosity is zero for a compressible fluid is known as the *Stokes assumption*.

6.6 INCOMPRESSIBLE NEWTONIAN FLUID

For an incompressible fluid, $\Delta \equiv D_{ii} = 0$ at all times. Thus the constitutive equation for such a fluid becomes

$$T_{ij} = -p\delta_{ij} + 2\mu D_{ij}. \quad (6.6.1)$$

From this equation, we have $T_{ii} = -3p + 2\mu D_{ii} = -3p$. That is,

$$p = \frac{T_{ii}}{3}. \quad (6.6.2)$$

Therefore, for an incompressible viscous fluid, the pressure p has the meaning of mean normal stress. The value of p does not depend explicitly on any kinematic quantities; its value is *indeterminate* as far as the fluid's mechanical behavior is concerned. In other words, since the fluid is incompressible, one can superpose any uniform pressure to the fluid without affecting its mechanical response. Thus, the pressure in an incompressible fluid is often known constitutively as the *indeterminate pressure*. Of course, in any given problem with prescribed boundary condition(s) for the pressure, the pressure field is determinate.

Since

$$D_{ij} = \frac{1}{2} \left(\frac{\partial v_i}{\partial x_j} + \frac{\partial v_j}{\partial x_i} \right), \quad (6.6.3)$$

where v_i are the velocity components, the constitutive equations can be written:

$$T_{ij} = -p\delta_{ij} + \mu \left(\frac{\partial v_i}{\partial x_j} + \frac{\partial v_j}{\partial x_i} \right). \quad (6.6.4)$$

In component form:

$$T_{11} = -p + 2\mu \frac{\partial v_1}{\partial x_1}, \quad T_{22} = -p + 2\mu \frac{\partial v_2}{\partial x_2}, \quad T_{33} = -p + 2\mu \frac{\partial v_3}{\partial x_3}, \quad (6.6.5)$$

and

$$T_{12} = \mu \left(\frac{\partial v_1}{\partial x_2} + \frac{\partial v_2}{\partial x_1} \right), \quad T_{13} = \mu \left(\frac{\partial v_1}{\partial x_3} + \frac{\partial v_3}{\partial x_1} \right), \quad T_{23} = \mu \left(\frac{\partial v_2}{\partial x_3} + \frac{\partial v_3}{\partial x_2} \right). \quad (6.6.6)$$

Example 6.6.1

Show that for an incompressible fluid,

$$\frac{\partial T_{ij}}{\partial x_j} = -\frac{\partial p}{\partial x_i} + \mu \frac{\partial^2 v_i}{\partial x_j \partial x_j}. \quad (6.6.7)$$

Solution

For an incompressible fluid,

$$T_{ij} = -p\delta_{ij} + \mu \left(\frac{\partial v_i}{\partial x_j} + \frac{\partial v_j}{\partial x_i} \right),$$

therefore,

$$\frac{\partial T_{ij}}{\partial x_j} = -\frac{\partial p}{\partial x_j} \delta_{ij} + \mu \frac{\partial^2 v_i}{\partial x_j \partial x_j} + \mu \frac{\partial^2 v_j}{\partial x_j \partial x_i} = -\frac{\partial p}{\partial x_i} + \mu \frac{\partial^2 v_i}{\partial x_j \partial x_j} + \mu \frac{\partial^2 v_j}{\partial x_j \partial x_i}.$$

Now, interchanging the order of differentiation in the last term of the preceding equation and noting that for an incompressible fluid $\partial v_j / \partial x_j = 0$, we have

$$\frac{\partial^2 v_j}{\partial x_j \partial x_i} = \frac{\partial}{\partial x_i} \left(\frac{\partial v_j}{\partial x_j} \right) = 0.$$

Thus,

$$\frac{\partial T_{ij}}{\partial x_j} = -\frac{\partial p}{\partial x_i} + \mu \frac{\partial^2 v_i}{\partial x_j \partial x_j}.$$

6.7 NAVIER-STOKES EQUATIONS FOR INCOMPRESSIBLE FLUIDS

Navier-Stokes equations are equations of motion written in terms of the velocity components of the fluid. The equations of motion in terms of the stress components are given by [see Eq. (4.7.5), Chapter 4].

$$\rho \left(\frac{\partial v_i}{\partial t} + v_j \frac{\partial v_i}{\partial x_j} \right) = \frac{\partial T_{ij}}{\partial x_j} + \rho B_i. \quad (6.7.1)$$

Substituting the constitutive equation [Eq. (6.6.4)] into the preceding equation, we obtain (see Example 6.6.1)

$$\rho \left(\frac{\partial v_i}{\partial t} + v_j \frac{\partial v_i}{\partial x_j} \right) = \rho B_i - \frac{\partial p}{\partial x_i} + \mu \frac{\partial^2 v_i}{\partial x_j \partial x_j}. \quad (6.7.2)$$

In component form,

$$\rho \left(\frac{\partial v_1}{\partial t} + v_1 \frac{\partial v_1}{\partial x_1} + v_2 \frac{\partial v_1}{\partial x_2} + v_3 \frac{\partial v_1}{\partial x_3} \right) = \rho B_1 - \frac{\partial p}{\partial x_1} + \mu \left(\frac{\partial^2 v_1}{\partial x_1^2} + \frac{\partial^2 v_1}{\partial x_2^2} + \frac{\partial^2 v_1}{\partial x_3^2} \right), \quad (6.7.3)$$

$$\rho \left(\frac{\partial v_2}{\partial t} + v_1 \frac{\partial v_2}{\partial x_1} + v_2 \frac{\partial v_2}{\partial x_2} + v_3 \frac{\partial v_2}{\partial x_3} \right) = \rho B_2 - \frac{\partial p}{\partial x_2} + \mu \left(\frac{\partial^2 v_2}{\partial x_1^2} + \frac{\partial^2 v_2}{\partial x_2^2} + \frac{\partial^2 v_2}{\partial x_3^2} \right), \quad (6.7.4)$$

$$\rho \left(\frac{\partial v_3}{\partial t} + v_1 \frac{\partial v_3}{\partial x_1} + v_2 \frac{\partial v_3}{\partial x_2} + v_3 \frac{\partial v_3}{\partial x_3} \right) = \rho B_3 - \frac{\partial p}{\partial x_3} + \mu \left(\frac{\partial^2 v_3}{\partial x_1^2} + \frac{\partial^2 v_3}{\partial x_2^2} + \frac{\partial^2 v_3}{\partial x_3^2} \right). \quad (6.7.5)$$

Or, in invariant form,

$$\rho \left\{ \frac{\partial \mathbf{v}}{\partial t} + (\nabla \mathbf{v}) \mathbf{v} \right\} = \rho \mathbf{B} - \nabla p + \mu \nabla^2 \mathbf{v}. \quad (6.7.6)$$

These are known as the *Navier-Stokes equations* of motion for incompressible Newtonian fluids. There are four unknown functions, v_1 , v_2 , v_3 , and p , in the three equations [Eqs. (6.7.3) to (6.7.5)]. The fourth equation is supplied by the continuity equation

$$\frac{\partial v_1}{\partial x_1} + \frac{\partial v_2}{\partial x_2} + \frac{\partial v_3}{\partial x_3} = 0, \quad (6.7.7)$$

which, in variant form, is

$$\operatorname{div} \mathbf{v} = 0. \quad (6.7.8)$$

Example 6.7.1

If all particles have their velocity vectors parallel to a fixed direction, the flow is said to be a *parallel flow* or a *unidirectional flow*. Show that for parallel flows of an incompressible Newtonian fluid the total normal compressive stress at any point on any plane parallel to and perpendicular to the direction of flow is the pressure p .

Solution

Let the direction of the flow be the x_1 -axis, then $v_2 = v_3 = 0$ and from the equation of continuity,

$$\frac{\partial v_1}{\partial x_1} = 0.$$

Thus, the velocity field for the parallel flow is

$$v_1 = v_1(x_2, x_3, t), \quad v_2 = 0, \quad v_3 = 0.$$

For this flow,

$$D_{11} = \frac{\partial v_1}{\partial x_1} = 0, \quad D_{22} = \frac{\partial v_2}{\partial x_2} = 0, \quad D_{33} = \frac{\partial v_3}{\partial x_3} = 0.$$

Therefore, from Eq. (6.6.5),

$$T_{11} = T_{22} = T_{33} = -p.$$

Example 6.7.2

Figure 6.7-1 shows a unidirectional flow in the x_1 direction. Let the z -axis point vertically upward (i.e., opposite the direction of gravity) from some reference plane. The piezometric head h at any point inside the flow is defined by the equation

$$h = \frac{p}{\rho g} + z. \quad (6.7.9)$$

Show that h is a constant for all points on any given plane that is perpendicular to the flow.

Solution

With the flow in the x_1 direction, with respect to a Cartesian coordinates (x_1, x_2, x_3) we have $v_2 = v_3 = 0$. From Eqs. (6.7.4) and (6.7.5), we have

$$\rho B_2 - \frac{\partial p}{\partial x_2} = 0, \quad \rho B_3 - \frac{\partial p}{\partial x_3} = 0. \quad (i)$$

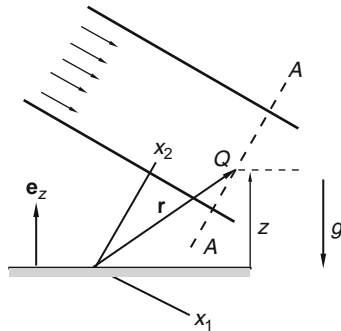
FIGURE 6.7-1

With \mathbf{e}_z denoting the unit vector in the direction of positive z -axis, the body force per unit mass is given by

$$\mathbf{B} = -g\mathbf{e}_z, \quad (ii)$$

so that

$$B_2 = \mathbf{B} \cdot \mathbf{e}_2 = -g(\mathbf{e}_z \cdot \mathbf{e}_2). \quad (iii)$$

Let \mathbf{r} be the position vector for a particle in the fluid with

$$\mathbf{r} = x_1\mathbf{e}_1 + x_2\mathbf{e}_2 + x_3\mathbf{e}_3. \quad (iv)$$

Then

$$z = \mathbf{e}_z \cdot \mathbf{r} = (\mathbf{e}_z \cdot \mathbf{e}_1)x_1 + (\mathbf{e}_z \cdot \mathbf{e}_2)x_2 + (\mathbf{e}_z \cdot \mathbf{e}_3)x_3, \quad (v)$$

so that

$$\frac{\partial z}{\partial x_2} = (\mathbf{e}_z \cdot \mathbf{e}_2). \quad (vi)$$

From Eq. (iii), we have

$$B_2 = -g(\mathbf{e}_z \cdot \mathbf{e}_2) = -g \frac{\partial z}{\partial x_2} = -\frac{\partial gz}{\partial x_2}. \quad (\text{vii})$$

Thus, from the first equation of Eq. (i), we have

$$-\rho \frac{\partial gz}{\partial x_2} - \frac{\partial p}{\partial x_2} = 0. \quad (\text{viii})$$

That is,

$$\frac{\partial}{\partial x_2} \left(\frac{p}{\rho g} + z \right) = 0. \quad (\text{ix})$$

Similarly, one can show that

$$\frac{\partial}{\partial x_3} \left(\frac{p}{\rho g} + z \right) = 0. \quad (\text{x})$$

Thus, the piezometric head h depends only on x_1 . That is, h is the same for any point lying in the plane $x_1 = \text{constant}$, which is a plane perpendicular to the unidirectional flow.

Example 6.7.3

For the unidirectional flow shown in Figure 6.7-2, find the pressure at point A as a function of p_a (atmospheric pressure), ρ (density of the fluid), h (depth of the fluid in the direction perpendicular to the flow), and θ (the angle of inclination of the flow).

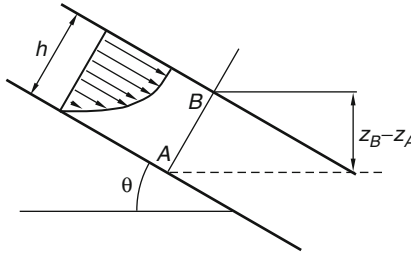

FIGURE 6.7-2

Solution

From the result of the previous example, the piezometric heads of point A and point B are the same. Since point B is on the free surface, its pressure is the atmospheric pressure; thus,

$$\frac{p_A}{\rho g} + z_A = \frac{p_B}{\rho g} + z_B = \frac{p_a}{\rho g} + z_B.$$

Thus,

$$p_A = p_a + \rho g(z_B - z_A) = p_a + (\rho gh) \cos \theta.$$

6.8 NAVIER-STOKES EQUATIONS FOR INCOMPRESSIBLE FLUIDS IN CYLINDRICAL AND SPHERICAL COORDINATES

A. Cylindrical Coordinates

With (v_r, v_θ, v_z) denoting the velocity components in (r, θ, z) directions, and the equations for $\nabla^2 \mathbf{v}$ presented in Chapter 2 for cylindrical coordinates, the Navier-Stokes equation for an incompressible fluid can be obtained as follows (see Problem 6.17):

$$\begin{aligned} \frac{\partial v_r}{\partial t} + v_r \frac{\partial v_r}{\partial r} + \frac{v_\theta}{r} \left(\frac{\partial v_r}{\partial \theta} - v_\theta \right) + v_z \frac{\partial v_r}{\partial z} &= -\frac{1}{\rho} \frac{\partial p}{\partial r} + B_r \\ &= \frac{\mu}{\rho} \left[\frac{\partial^2 v_r}{\partial r^2} + \frac{1}{r^2} \frac{\partial^2 v_r}{\partial \theta^2} + \frac{\partial^2 v_r}{\partial z^2} + \frac{1}{r} \frac{\partial v_r}{\partial r} - \frac{2}{r^2} \frac{\partial v_\theta}{\partial \theta} - \frac{v_r}{r^2} \right], \end{aligned} \quad (6.8.1)$$

$$\begin{aligned} \frac{\partial v_\theta}{\partial t} + v_r \frac{\partial v_\theta}{\partial r} + \frac{v_\theta}{r} \left(\frac{\partial v_\theta}{\partial \theta} + v_r \right) + v_z \frac{\partial v_\theta}{\partial z} &= -\frac{1}{\rho r} \frac{\partial p}{\partial \theta} + B_\theta \\ + \frac{\mu}{\rho} \left[\frac{\partial^2 v_\theta}{\partial r^2} + \frac{1}{r^2} \frac{\partial^2 v_\theta}{\partial \theta^2} + \frac{\partial^2 v_\theta}{\partial z^2} + \frac{1}{r} \frac{\partial v_\theta}{\partial r} + \frac{2}{r^2} \frac{\partial v_r}{\partial \theta} - \frac{v_\theta}{r^2} \right], \end{aligned} \quad (6.8.2)$$

$$\begin{aligned} \frac{\partial v_z}{\partial t} + v_r \frac{\partial v_z}{\partial r} + \frac{v_\theta}{r} \frac{\partial v_z}{\partial \theta} + v_z \frac{\partial v_z}{\partial z} &= -\frac{1}{\rho} \frac{\partial p}{\partial z} + B_z \\ + \frac{\mu}{\rho} \left[\frac{\partial^2 v_z}{\partial r^2} + \frac{1}{r^2} \frac{\partial^2 v_z}{\partial \theta^2} + \frac{\partial^2 v_z}{\partial z^2} + \frac{1}{r} \frac{\partial v_z}{\partial r} \right]. \end{aligned} \quad (6.8.3)$$

The equation of continuity takes the form

$$\frac{1}{r} \frac{\partial}{\partial r} (r v_r) + \frac{1}{r} \frac{\partial v_\theta}{\partial \theta} + \frac{\partial v_z}{\partial z} = 0. \quad (6.8.4)$$

B. Spherical Coordinates

With (v_r, v_θ, v_ϕ) denoting the velocity components in (r, θ, ϕ) directions, and the equations for $\nabla^2 \mathbf{v}$ presented in Chapter 2 for spherical coordinates, the Navier-Stokes equation for an incompressible fluid can be obtained as follows (see Problem 6.18):

$$\begin{aligned} \frac{\partial v_r}{\partial t} + v_r \frac{\partial v_r}{\partial r} + \frac{v_\theta}{r} \frac{\partial v_r}{\partial \theta} + \frac{v_\phi}{r \sin \theta} \frac{\partial v_r}{\partial \phi} - \frac{(v_\theta^2 + v_\phi^2)}{r} &= -\frac{1}{\rho} \frac{\partial p}{\partial r} + B_r + \frac{\mu}{\rho} \left[\frac{\partial}{\partial r} \left(\frac{1}{r^2} \frac{\partial}{\partial r} (r^2 v_r) \right) \right. \\ &+ \frac{1}{r^2 \sin \theta} \frac{\partial}{\partial \theta} \left(\sin \theta \frac{\partial v_r}{\partial \theta} \right) + \frac{1}{r^2 \sin^2 \theta} \frac{\partial^2 v_r}{\partial \phi^2} - \frac{2}{r^2 \sin \theta} \frac{\partial}{\partial \theta} (v_\theta \sin \theta) - \frac{2}{r^2 \sin \theta} \frac{\partial v_\phi}{\partial \phi} \left. \right], \end{aligned} \quad (6.8.5)$$

$$\begin{aligned} \frac{\partial v_\theta}{\partial t} + v_r \frac{\partial v_\theta}{\partial r} + \frac{v_\theta}{r} \left(\frac{\partial v_\theta}{\partial \theta} + v_r \right) + \frac{v_\phi}{r \sin \theta} \left(\frac{\partial v_\theta}{\partial \phi} - v_\phi \cos \theta \right) = -\frac{1}{\rho r} \frac{\partial p}{\partial \theta} + B_\theta + \\ \frac{\mu}{\rho} \left(\frac{1}{r^2} \right) \left[\frac{\partial}{\partial r} \left(r^2 \frac{\partial v_\theta}{\partial r} \right) + \frac{\partial}{\partial \theta} \left(\frac{1}{\sin \theta} \frac{\partial}{\partial \theta} (v_\theta \sin \theta) \right) + \frac{1}{\sin^2 \theta} \frac{\partial^2 v_\theta}{\partial \phi^2} + \frac{2 \partial v_r}{\partial \theta} - \frac{2 \cot \theta}{\sin \theta} \frac{\partial v_\phi}{\partial \phi} \right], \end{aligned} \quad (6.8.6)$$

$$\begin{aligned} \frac{\partial v_\phi}{\partial t} + v_r \frac{\partial v_\phi}{\partial r} + \frac{v_\theta}{r} \frac{\partial v_\phi}{\partial \theta} + \frac{v_\phi}{r \sin \theta} \left(\frac{\partial v_\phi}{\partial \phi} + v_r \sin \theta + v_\theta \cos \theta \right) = -\frac{1}{\rho r \sin \theta} \frac{\partial p}{\partial \phi} \\ + B_\phi + \frac{\mu}{\rho} \left[\frac{1}{r^2} \frac{\partial}{\partial r} \left(r^2 \frac{\partial v_\phi}{\partial r} \right) + \frac{1}{r^2} \frac{\partial}{\partial \theta} \left(\frac{1}{\sin \theta} \frac{\partial}{\partial \theta} (v_\phi \sin \theta) \right) + \frac{1}{r^2 \sin^2 \theta} \frac{\partial^2 v_\phi}{\partial \phi^2} + \frac{2}{r^2 \sin \theta} \frac{\partial v_r}{\partial \phi} + \frac{2 \cot \theta}{r^2 \sin \theta} \frac{\partial v_\theta}{\partial \phi} \right]. \end{aligned} \quad (6.8.7)$$

The equation of continuity takes the form

$$\frac{1}{r^2} \frac{\partial}{\partial r} (r^2 v_r) + \frac{1}{r \sin \theta} \frac{\partial}{\partial \theta} (v_\theta \sin \theta) + \frac{1}{r \sin \theta} \frac{\partial v_\phi}{\partial \phi} = 0. \quad (6.8.8)$$

6.9 BOUNDARY CONDITIONS

On a rigid boundary, we shall impose the *nonslip condition* (also known as the *adherence condition*), i.e., the fluid layer next to a rigid surface moves with that surface; in particular, if the surface is at rest, the velocity of the fluid at the surface is zero. The nonslip condition is well supported by experiments for practically all fluids, including those that do not wet the surface (e.g., mercury) and non-Newtonian fluids (e.g., most polymeric fluids).

6.10 STREAMLINE, PATHLINE, STEADY, UNSTEADY, LAMINAR, AND TURBULENT FLOW

A. Streamline

A *streamline* at time t is a curve for which the tangent at every point has the direction of the instantaneous velocity vector of the particle at the point. Experimentally, streamlines on the surface of a fluid are often obtained by sprinkling it with reflecting particles and making a short-time exposure photograph of the surface. Each reflecting particle produces a short line on the photograph, approximating the tangent to a streamline. Mathematically, streamlines can be obtained from the velocity field $\mathbf{v}(\mathbf{x}, t)$ as follows.

Let $\mathbf{x} = \mathbf{x}(s)$ be the parametric equation for the streamline at time t , which passes through a given point \mathbf{x}_0 . Clearly, the vector $d\mathbf{x}/ds$ at any given s is tangent to the curve at that s , and an s can always be chosen so that $d\mathbf{x}/ds = \mathbf{v}$. If we let $s = 0$ correspond to the position \mathbf{x}_0 , then, for a given velocity field $\mathbf{v}(\mathbf{x}, t)$, the streamline that passes through the point \mathbf{x}_0 can be determined from the following differential system:

$$\frac{d\mathbf{x}}{ds} = \mathbf{v}(\mathbf{x}, t), \quad (6.10.1)$$

with

$$\mathbf{x}(0) = \mathbf{x}_0. \quad (6.10.2)$$

Example 6.10.1

Given the velocity field

$$v_1 = \frac{kx_1}{1 + \alpha t}, \quad v_2 = kx_2, \quad v_3 = 0, \quad (i)$$

find the streamline that passes through the point (a_1, a_2, a_3) at time t .

Solution

With respect to the Cartesian coordinates (x_1, x_2, x_3) , we have, from Eqs. (6.10.1) and (6.10.2),

$$\frac{dx_1}{ds} = \frac{kx_1}{1 + \alpha t}, \quad \frac{dx_2}{ds} = kx_2, \quad \frac{dx_3}{ds} = 0, \quad (ii)$$

and

$$x_1(0) = a_1, \quad x_2(0) = a_2, \quad x_3(0) = a_3. \quad (iii)$$

Thus,

$$\int_{a_1}^{x_1} \frac{dx_1}{x_1} = k \int_0^s \frac{ds}{1 + \alpha t}, \quad \int_{a_2}^{x_2} \frac{dx_2}{x_2} = k \int_0^s ds, \quad \int_{a_3}^{x_3} \frac{dx_3}{x_3} = 0. \quad (iv)$$

Integrating the preceding equations, we obtain

$$x_1 = a_1 \exp\left\{\frac{ks}{1 + \alpha t}\right\}, \quad x_2 = a_2 e^{ks}, \quad x_3 = a_3. \quad (v)$$

Equations (v) give the desired streamline equations.

B. Pathline

A *pathline* is the path traversed by a fluid particle. To photograph a pathline, it is necessary to use long time exposure of a reflecting particle. Mathematically, the pathline of a particle that was at \mathbf{X} at time t_0 can be obtained from the velocity field $\mathbf{v}(\mathbf{x}, t)$ as follows: Let $\mathbf{x} = \mathbf{x}(t)$ be the pathline; then

$$\frac{d\mathbf{x}}{dt} = \mathbf{v}(\mathbf{x}, t), \quad (6.10.3)$$

with

$$\mathbf{x}(t_0) = \mathbf{X}. \quad (6.10.4)$$

Example 6.10.2

For the velocity field of the previous example, find the pathline for a particle that was at (X_1, X_2, X_3) at time t_0 .

Solution

We have, according to Eqs. (6.10.3) and (6.10.4),

$$\frac{dx_1}{dt} = \frac{kx_1}{1 + \alpha t}, \quad \frac{dx_2}{dt} = kx_2, \quad \frac{dx_3}{dt} = 0, \quad (i)$$

and

$$x_1(t_0) = X_1, \quad x_2(t_0) = X_2, \quad x_3(t_0) = X_3. \quad (\text{ii})$$

Thus,

$$\int_{X_1}^{x_1} \frac{dx_1}{x_1} = k \int_{t_0}^t \frac{dt}{1 + \alpha t}, \quad \int_{X_2}^{x_2} \frac{dx_2}{x_2} = k \int_{t_0}^t dt, \quad x_3 = X_3. \quad (\text{iii})$$

Thus,

$$\ln x_1 - \ln X_1 = \frac{k}{\alpha} [\ln(1 + \alpha t) - \ln(1 + \alpha t_0)], \quad \ln x_2 - \ln X_2 = k(t - t_0), \quad x_3 = X_3, \quad (\text{iv})$$

so that

$$x_1 = X_1 \left[\frac{(1 + \alpha t)}{(1 + \alpha t_0)} \right]^{k/\alpha}, \quad x_2 = X_2 e^{k(t-t_0)}, \quad x_3 = X_3. \quad (\text{v})$$

C. Steady and Unsteady Flow

A flow is called *steady* if at every fixed location nothing changes with time. Otherwise, the flow is called *unsteady*. It is important to note, however, that in a steady flow, the velocity, acceleration, temperature, etc. of a given fluid particle in general change with time. In other words, let Ψ be any dependent variable; then, in a steady flow, $(\partial\Psi/\partial t)_{x\text{-fixed}} = 0$, but $D\Psi/Dt$ is in general not zero. For example, the steady flow given by the velocity field

$$v_1 = kx_1, \quad v_2 = -kx_2, \quad v_3 = 0$$

has a nonzero acceleration field given by

$$a_1 = \frac{Dv_1}{Dt} = k^2x_1, \quad a_2 = \frac{Dv_2}{Dt} = k^2x_2, \quad a_3 = 0.$$

We remark that for steady flows, a pathline is also a streamline, and vice versa.

D. Laminar and Turbulent Flow

A *laminar* flow is a very orderly flow in which the fluid particles move in smooth layers, or *laminae*, sliding over particles in adjacent laminae without mixing with them. Such flows are generally realized at slow speed. For the case of water (viscosity μ and density ρ) flowing through a tube of circular cross-section of diameter d with an average velocity v_m , it was found by Reynolds, who observed the thin filaments of dye in the tube, that when the dimensionless parameter N_R (now known as the *Reynolds number*), defined by

$$N_R = \frac{v_m \rho d}{\mu}, \quad (6.10.5)$$

is less than a certain value (approximately 2100), the thin filament of dye was maintained intact throughout the tube, forming a straight line parallel to the axis of the tube. Any accidental disturbances were rapidly

obliterated. As the Reynolds number is increased, the flow becomes increasingly sensitive to small perturbations until a stage is reached wherein the dye filament breaks and diffuses through the flowing water. This phenomenon of irregular intermingling of fluid particle in the flow is termed *turbulence*. In the case of a pipe flow, the upper limit of the Reynolds number, beyond which the flow is turbulent, is indeterminate. Depending on the experimental setup and the initial quietness of the fluid, this upper limit can be as high as 100,000.

In the following sections, we restrict ourselves to the study of laminar flows of an incompressible Newtonian fluid only. It is therefore to be understood that the solutions presented are valid only within certain limits of some parameter (such as the Reynolds number) governing the stability of the flow.

6.11 PLANE COUETTE FLOW

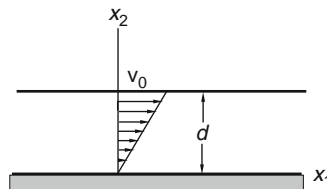

FIGURE 6.11-1

The steady unidirectional flow, under zero pressure gradients in the flow direction, of an incompressible viscous fluid between two horizontal plates of infinite extent, one fixed and the other moving in its own plane with a constant velocity v_0 , is known as the *plane Couette flow* (Figure 6.11-1). Let x_1 be the direction of the flow; then $v_2 = v_3 = 0$. It follows from the continuity equation that v_1 cannot depend on x_1 . Let x_1x_2 plane be the plane of flow; then the velocity field for the plane Couette flow is of the form

$$v_1 = v(x_2), \quad v_2 = 0, \quad v_3 = 0. \quad (6.11.1)$$

From the Navier-Stokes equation and the boundary conditions $v(0) = 0$ and $v(d) = v_0$, it can be easily obtained that

$$v(x_2) = \frac{v_0 x_2}{d}. \quad (6.11.2)$$

6.12 PLANE POISEUILLE FLOW

The *plane Poiseuille flow* is the two-dimensional steady unidirectional flow between two fixed plates of infinite extent. Let x_1x_2 be the plane of flow with x_1 in the direction of the flow; then the velocity field is of the form

$$v_1 = v(x_2), \quad v_2 = 0, \quad v_3 = 0. \quad (6.12.1)$$

Let us first consider the case where gravity is neglected. We shall show later that the presence of gravity does not at all affect the flow field; it only modifies the pressure field.

In the absence of body forces, the Navier-Stokes equations, Eqs. (6.7.3) to (6.7.5), yield

$$\frac{\partial p}{\partial x_1} = \mu \frac{d^2 v}{dx_2^2}, \quad \frac{\partial p}{\partial x_2} = 0, \quad \frac{\partial p}{\partial x_3} = 0. \quad (6.12.2)$$

From the second and third equations of Eq. (6.12.2), we see that the pressure p cannot depend on x_2 and x_3 . If we differentiate the first equation with respect to x_1 , and noting that the right-hand side is a function of x_2 only, we obtain

$$\frac{d^2 p}{dx_1^2} = 0. \quad (6.12.3)$$

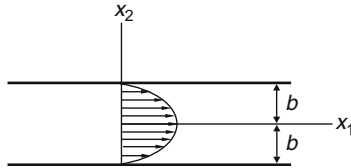

FIGURE 6.12-1

Thus,

$$\frac{dp}{dx_1} = \text{a constant}, \quad (6.12.4)$$

i.e., in a plane Poiseuille flow, the pressure gradient is a constant along the flow direction. This pressure gradient is the driving force for the flow. Let

$$\frac{dp}{dx_1} \equiv -\alpha, \quad (6.12.5)$$

so that a positive α corresponds to the case where the pressure decreases along the flow direction. Going back to the first equation in Eq. (6.12.2), we now have

$$\mu \frac{d^2 v}{dx_2^2} = -\alpha. \quad (6.12.6)$$

Integrating the preceding equation twice, we get

$$\mu v = -\frac{\alpha x_2^2}{2} + Cx_2 + D. \quad (6.12.7)$$

The integration constants C and D are to be determined from the boundary conditions

$$v(-b) = v(+b) = 0. \quad (6.12.8)$$

They are $C = 0$ and $D = \alpha b^2/2$; thus,

$$v(x_2) = \frac{\alpha}{2\mu} (b^2 - x_2^2). \quad (6.12.9)$$

Equation (6.12.9) shows that the profile is a parabola, with a maximum velocity at the mid-channel given by

$$v_{\max} = \frac{\alpha}{2\mu} b^2. \quad (6.12.10)$$

The flow volume per unit time per unit width (in the x_3 direction) passing any cross-section can be obtained by integration:

$$Q = \int_{-b}^b v dx_2 = \frac{\alpha}{\mu} \left(\frac{2b^3}{3} \right). \quad (6.12.11)$$

The average velocity is

$$\bar{v} = \frac{Q}{2b} = \frac{\alpha b^2}{\mu 3}. \quad (6.12.12)$$

We shall now prove that in the presence of gravity and independent of the inclination of the channel, the Poiseuille flow always has the parabolic velocity profile given by Eq. (6.12.9).

Let \mathbf{k} be the unit vector pointing upward in the vertical direction; then the body force is

$$\mathbf{B} = -g\mathbf{k}, \quad (6.12.13)$$

and the components of the body force in the x_1 , x_2 , and x_3 directions are

$$B_1 = -g(\mathbf{e}_1 \cdot \mathbf{k}), \quad B_2 = -g(\mathbf{e}_2 \cdot \mathbf{k}), \quad B_3 = -g(\mathbf{e}_3 \cdot \mathbf{k}). \quad (6.12.14)$$

Let \mathbf{r} be the position vector of a fluid particle so that

$$\mathbf{r} = x_1\mathbf{e}_1 + x_2\mathbf{e}_2 + x_3\mathbf{e}_3, \quad (6.12.15)$$

and let y be the vertical coordinate. Then

$$y = \mathbf{r} \cdot \mathbf{k} = x_1(\mathbf{e}_1 \cdot \mathbf{k}) + x_2(\mathbf{e}_2 \cdot \mathbf{k}) + x_3(\mathbf{e}_3 \cdot \mathbf{k}), \quad (6.12.16)$$

and

$$\frac{\partial y}{\partial x_1} = (\mathbf{e}_1 \cdot \mathbf{k}), \quad \frac{\partial y}{\partial x_2} = (\mathbf{e}_2 \cdot \mathbf{k}), \quad \frac{\partial y}{\partial x_3} = (\mathbf{e}_3 \cdot \mathbf{k}). \quad (6.12.17)$$

Equations (6.12.17) and (6.12.14) then give

$$B_1 = -g \frac{\partial y}{\partial x_1}, \quad B_2 = -g \frac{\partial y}{\partial x_2}, \quad B_3 = -g \frac{\partial y}{\partial x_3}. \quad (6.12.18)$$

The Navier-Stokes equations

$$\rho B_1 - \frac{\partial p}{\partial x_1} + \mu \frac{d^2 v}{dx_1^2} = 0, \quad \rho B_2 - \frac{\partial p}{\partial x_2} = 0, \quad \rho B_3 - \frac{\partial p}{\partial x_3} = 0, \quad (6.12.19)$$

then become

$$\frac{\partial(p + \rho g y)}{\partial x_1} = \mu \frac{\partial^2 v}{\partial x_1^2}, \quad \frac{\partial(p + \rho g y)}{\partial x_2} = 0, \quad \frac{\partial(p + \rho g y)}{\partial x_3} = 0. \quad (6.12.20)$$

These equations are the same as Eq. (6.12.2) except that the pressure p is replaced by $p + \rho g y$. From these equations, one clearly will obtain the same parabolic velocity profile, except that the driving force in this case is the gradient of $p + \rho g y$ in the flow direction instead of simply the gradient of p .

6.13 HAGEN-POISEUILLE FLOW

The so-called *Hagen-Poiseuille flow* is a steady unidirectional axisymmetric flow in a circular cylinder. Thus, we look for the velocity field in cylindrical coordinates in the following form:

$$v_r = 0, \quad v_\theta = 0, \quad v_z = v(r). \quad (6.13.1)$$

For whatever $v(r)$, the velocity field given by Eq. (6.13.1) obviously satisfies the equation of continuity [Eq. (6.8.4)]:

$$\frac{1}{r} \frac{\partial}{\partial r} (rv_r) + \frac{1}{r} \frac{\partial v_\theta}{\partial \theta} + \frac{\partial v_z}{\partial z} = 0. \quad (6.13.2)$$

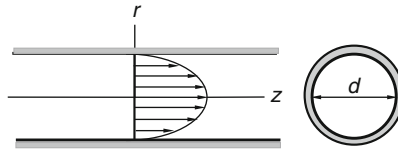

FIGURE 6.13-1

In the absence of body forces, the Navier-Stokes equations, in cylindrical coordinates for the velocity field of Eqs. (6.13.1), are from Eqs. (6.8.1) to (6.8.3).

$$0 = -\frac{\partial p}{\partial r}, \quad 0 = -\frac{\partial p}{\partial \theta}, \quad 0 = -\frac{\partial p}{\partial z} + \mu \left[\frac{1}{r} \frac{d}{dr} \left(r \frac{dv}{dr} \right) \right]. \quad (6.13.3)$$

From the preceding equations, we see clearly that p depends only on z and

$$\frac{d^2 p}{dz^2} = 0. \quad (6.13.4)$$

Thus, dp/dz is a constant. Let

$$\alpha \equiv -\frac{dp}{dz}, \quad (6.13.5)$$

then

$$-\frac{\alpha}{\mu} = \frac{1}{r} \frac{d}{dr} \left(r \frac{dv}{dr} \right). \quad (6.13.6)$$

Integration of the preceding equation gives

$$v = -\frac{\alpha r^2}{4\mu} + b \ln r + c. \quad (6.13.7)$$

Since v must be bounded in the flow region, the integration constant b must be zero. Now the nonslip condition on the cylindrical wall demands that

$$v = 0 \quad \text{at} \quad r = d/2, \quad (6.13.8)$$

where d is the diameter of the pipe. Thus, $c = (\alpha/\mu)(d^2/16)$ and

$$v = \frac{\alpha}{4\mu} \left(\frac{d^2}{4} - r^2 \right). \quad (6.13.9)$$

The preceding equation states that the velocity over the cross-section is distributed in the form of a paraboloid. The maximum velocity is at $r = 0$; its value is

$$v_{\max} = \frac{\alpha d^2}{16\mu}. \quad (6.13.10)$$

The mean velocity is

$$\bar{v} = \frac{1}{(\pi d^2/4)} \int_A v dA = \frac{\alpha d^2}{32\mu} = \frac{v_{\max}}{2}. \quad (6.13.11)$$

and the volume flow rate is

$$Q = \left(\frac{\pi d^2}{4} \right) \bar{v} = \frac{\alpha \pi d^4}{128\mu}, \quad (6.13.12)$$

where $\alpha = -dp/dz$ [see Eq. (6.13.5)]. As is in the case of a plane Poiseuille flow, if the effect of gravity is included, the velocity profile in the pipe remains the same as that given by Eq. (6.13.9); however, the driving force now is the gradient of $(p + \rho gy)$, where y is the vertical height measured from some reference datum.

6.14 PLANE COUETTE FLOW OF TWO LAYERS OF INCOMPRESSIBLE VISCOUS FLUIDS

Let the viscosity and the density of the top layer be μ_1 and ρ_1 , respectively, and those of the bottom layer be μ_2 and ρ_2 , respectively. Let x_1 be the direction of flow, and let $x_2 = 0$ be the interface between the two layers. We look for steady unidirectional flows of the two layers between the infinite plates $x_2 = +b_1$ and $x_2 = -b_2$. The plate $x_2 = -b_2$ is fixed and the plate $x_2 = +b_1$ is moving on its own plane with velocity v_0 . The pressure gradient in the flow direction is assumed to be zero (Figure 6.14-1).

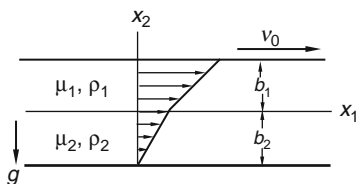

FIGURE 6.14-1

Let the velocity distribution in the top layer be

$$v_1^{(1)} = v^{(1)}(x_2), \quad v_2^{(1)} = v_3^{(1)} = 0, \quad (6.14.1)$$

and that in the bottom layer be

$$v_1^{(2)} = v^{(2)}(x_2), \quad v_2^{(2)} = v_3^{(2)} = 0. \quad (6.14.2)$$

The equation of continuity is clearly satisfied for each layer. The Navier-Stokes equations give

$$\text{Layer 1: } 0 = \mu_1 \frac{d^2 v^{(1)}}{dx_2^2}, \quad 0 = -\frac{\partial p^{(1)}}{\partial x_2} - \rho_1 g, \quad 0 = -\frac{\partial p^{(1)}}{\partial x_3}, \quad (6.14.3)$$

$$\text{Layer 2: } 0 = \mu_2 \frac{d^2 v^{(2)}}{dx_2^2}, \quad 0 = -\frac{\partial p^{(2)}}{\partial x_2} - \rho_2 g, \quad 0 = -\frac{\partial p^{(2)}}{\partial x_3}. \quad (6.14.4)$$

Integrations of the preceding equations give

$$v^{(1)} = A_1 x_2 + B_1, \quad p^{(1)} = -\rho_1 g x_2 + C_1, \quad (6.14.5)$$

and

$$v^{(2)} = A_2 x_2 + B_2, \quad p^{(2)} = -\rho_2 g x_2 + C_2. \quad (6.14.6)$$

The boundary condition on the bottom fixed plate is

$$v^{(2)} = 0 \quad \text{at} \quad x_2 = -b_2. \quad (6.14.7)$$

The boundary condition on the top moving plate is

$$v^{(1)} = v_0 \quad \text{at} \quad x_2 = +b_1. \quad (6.14.8)$$

The interfacial conditions between the two layers are

$$v^{(1)} = v^{(2)} \quad \text{at} \quad x_2 = 0, \quad (6.14.9)$$

and

$$\mathbf{t}_{-e_2}^{(1)} = -\mathbf{t}_{+e_2}^{(2)} \quad \text{or} \quad \mathbf{T}^{(1)} e_2 = \mathbf{T}^{(2)} e_2 \quad \text{at} \quad x_2 = 0. \quad (6.14.10)$$

Equation (6.14.9) states that there is no slip between the two layers, and Eq. (6.14.10) states that the stress vector on layer 1 is equal and opposite to that on layer 2 in accordance with Newton's third law. In terms of stress components, Eq. (6.14.10) becomes

$$T_{12}^{(1)} = T_{12}^{(2)}, \quad T_{22}^{(1)} = T_{22}^{(2)}, \quad T_{32}^{(1)} = T_{32}^{(2)} \quad \text{at} \quad x_2 = 0. \quad (6.14.11)$$

That is, these stress components must be continuous across the fluid interface in accordance with Newton's third law. Now

$$T_{12}^{(1)} = \mu_1 \frac{dv^{(1)}}{dx_2}, \quad T_{12}^{(2)} = \mu_2 \frac{dv^{(2)}}{dx_2}, \quad T_{32}^{(1)} = 0, \quad T_{32}^{(2)} = 0, \quad (6.14.12)$$

and

$$T_{22}^{(1)} = -p^{(1)}, \quad T_{22}^{(2)} = -p^{(2)}. \quad (6.14.13)$$

Thus, we have

$$\mu_1 \frac{dv^{(1)}}{dx_2} = \mu_2 \frac{dv^{(2)}}{dx_2} \quad \text{and} \quad p^{(1)} = p^{(2)} \quad \text{at} \quad x_2 = 0. \quad (6.14.14)$$

Using the boundary conditions, Eqs. (6.14.7), (6.14.8), (6.14.9), and (6.14.14), we obtain

$$B_2 = A_2 b_2, \quad B_1 = v_0 - A_1 b_1, \quad B_1 = B_2, \quad \mu_1 A_1 = \mu_2 A_2. \quad (6.14.15)$$

Equations (6.14.15) are four equations for the four unknowns, A_1 , A_2 , B_1 , and B_2 ; these can be easily obtained to be

$$A_1 = \frac{\mu_2 v_o}{(\mu_1 b_2 + \mu_2 b_1)}, B_1 = \frac{(\mu_1 v_o b_2)}{(\mu_1 b_2 + \mu_2 b_1)}, A_2 = \frac{\mu_1 v_o}{(\mu_1 b_2 + \mu_2 b_1)}, B_2 = \frac{b_2 \mu_1 v_o}{(\mu_1 b_2 + \mu_2 b_1)}. \quad (6.14.16)$$

Thus, the velocity distributions are

$$v_1^{(1)} = \frac{(\mu_2 x_2 + \mu_1 b_2) v_o}{(\mu_2 b_1 + \mu_1 b_2)}, v_2^{(1)} = v_3^{(1)} = 0 \quad \text{and} \quad v_1^{(2)} = \frac{(\mu_1 x_2 + \mu_1 b_2) v_o}{(\mu_2 b_1 + \mu_1 b_2)}, v_2^{(2)} = v_3^{(2)} = 0. \quad (6.14.7)$$

Finally, the condition $p^{(1)} = p^{(2)}$ at $x_2 = 0$ gives $C_1 = C_2 = p_o$, so that

$$p^{(1)} = -\rho_1 g x_2 + p_o, \quad p^{(2)} = -\rho_2 g x_2 + p_o \quad (6.14.18)$$

where p_o is the pressure at the interface, which is a prescribed value.

6.15 COUETTE FLOW

The laminar steady two-dimensional flow of an incompressible viscous fluid between two coaxial infinitely long cylinders caused by the rotation of either one or both cylinders with constant angular velocities is known as *Couette flow*.

For this flow, we look for the velocity field in the following form in cylindrical coordinates:

$$v_r = 0, \quad v_\theta = v(r), \quad v_z = 0. \quad (6.15.1)$$

This velocity field obviously satisfies the equation of continuity for any $v(r)$ [Eq. (6.8.4)],

$$\frac{1}{r} \frac{\partial}{\partial r} (r v_r) + \frac{1}{r} \frac{\partial v_\theta}{\partial \theta} + \frac{\partial v_z}{\partial z} = 0. \quad (6.15.2)$$

In the absence of body forces and taking into account the rotational symmetry of the flow (i.e., nothing depends on θ), we have, from the Navier-Stokes equation in θ direction, Eq. (6.8.2) for the two-dimensional flow,

$$\frac{d^2 v}{dr^2} + \frac{1}{r} \frac{dv}{dr} - \frac{v}{r^2} = 0. \quad (6.15.3)$$

The general solution for the preceding equation is

$$v = Ar + \frac{B}{r}. \quad (6.15.4)$$

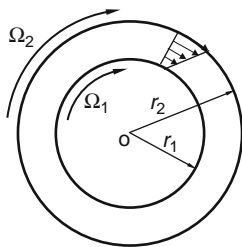

FIGURE 6.15-1

Let r_1 and r_2 denote the radii of the inner and outer cylinders, respectively; Ω_1 and Ω_2 their respective angular velocities (Figure 6.15-1). Then the boundary conditions are

$$v(r_1) = r_1\Omega_1, \quad v(r_2) = r_2\Omega_2. \quad (6.15.5)$$

Equations (6.15.4) and (6.15.5) give

$$r_1\Omega_1 = Ar_1 + \frac{B}{r_1}, \quad r_2\Omega_2 = Ar_2 + \frac{B}{r_2}, \quad (6.15.6)$$

so that

$$A = \frac{\Omega_2 r_2^2 - \Omega_1 r_1^2}{r_2^2 - r_1^2}, \quad B = \frac{r_1^2 r_2^2 (\Omega_1 - \Omega_2)}{r_2^2 - r_1^2}, \quad (6.15.7)$$

and

$$v_\theta = v = \frac{1}{(r_2^2 - r_1^2)} \left[(\Omega_2 r_2^2 - \Omega_1 r_1^2) r - \frac{r_1^2 r_2^2}{r} (\Omega_2 - \Omega_1) \right], \quad v_r = v_z = 0. \quad (6.15.8)$$

It can be easily obtained that the torques per unit length of the cylinder which must be applied to the cylinders to maintain the flow are given by

$$\mathbf{M} = \pm \mathbf{e}_z \frac{4\pi\mu r_1^2 r_2^2 (\Omega_1 - \Omega_2)}{r_2^2 - r_1^2}, \quad (6.15.9)$$

where the plus sign is for the outer wall and the minus sign is for the inner wall. We note that when $\Omega_1 = \Omega_2$, the flow is that of a rigid body rotation with constant angular velocity; there is no viscous stress on either cylinder.

6.16 FLOW NEAR AN OSCILLATING PLANE

Let us consider the following unsteady parallel flow near an oscillating plane:

$$v_1 = v(x_2, t), \quad v_2 = 0, \quad v_3 = 0. \quad (6.16.1)$$

Omitting body forces and assuming a constant pressure field, the only nontrivial Navier-Stokes equation is

$$\rho \frac{\partial v}{\partial t} = \mu \frac{\partial^2 v}{\partial x_2^2}. \quad (6.16.2)$$

It can be easily verified that

$$v = ae^{-\beta x_2} \cos(\omega t - \beta x_2 + \varepsilon), \quad (6.16.3)$$

satisfies the preceding equation if

$$\beta = \sqrt{\rho\omega/2\mu}. \quad (6.16.4)$$

From Eq. (6.16.3), the fluid velocity at $x_2 = 0$ is (see Figure 6.16-1)

$$v = a \cos(\omega t + \varepsilon). \quad (6.16.5)$$

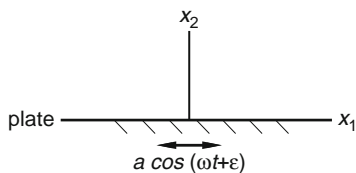

FIGURE 6.16-1

Thus, the solution Eq. (6.16.3), together with (6.16.4), represents the velocity field of an infinite extent of liquid lying in the region $x_2 \geq 0$ and bounded by a plate at $x_2 = 0$, which executes simple harmonic oscillations of amplitude a and circular frequency ω . It represents a transverse wave of wavelength $2\pi/\beta$, propagating inward from the boundary with a phase velocity ω/β but with rapidly diminishing amplitude—the falling off within a wavelength being in the ratio $e^{-2\pi}$ ($=1/535$). Thus, we see that the influence of viscosity extends only to a short distance from the plate performing rapid oscillation of small amplitude a .

6.17 DISSIPATION FUNCTIONS FOR NEWTONIAN FLUIDS

The rate of work done P by the stress vectors and the body forces on a material particle of a continuum was derived in Chapter 4 as [see Eq. (4.12.1)]

$$P = \frac{D}{Dt}(K.E.) + P_s dV. \quad (6.17.1)$$

The first term of the preceding equation is the rate of change of kinetic energy ($K.E.$), and the second term $P_s dV$ is the rate of work done to change the volume and shape of the particle of volume dV . Here P_s denotes this rate of change per unit volume, which is also known as *stress working*, or *stress power*. In terms of the stress components and the velocity gradient, the stress power is given by

$$P_s = T_{ij} \frac{\partial v_i}{\partial x_j}. \quad (6.17.2)$$

In this section, we compute the stress power in terms of D_{ij} , the components of the rate of deformation tensor for a Newtonian fluid.

A. Incompressible Newtonian Fluid

We have

$$T_{ij} = -p\delta_{ij} + T'_{ij}, \quad (6.17.3)$$

thus,

$$T_{ij} \frac{\partial v_i}{\partial x_j} = -p \frac{\partial v_i}{\partial x_i} + T'_{ij} \frac{\partial v_i}{\partial x_j}. \quad (6.17.4)$$

For incompressible fluid, $\partial v_i / \partial x_i = 0$; therefore,

$$T_{ij} \frac{\partial v_i}{\partial x_j} = T'_{ij} \frac{\partial v_i}{\partial x_j} = 2\mu D_{ij} \frac{\partial v_i}{\partial x_j} = 2\mu D_{ij} (D_{ij} + W_{ij}) = 2\mu D_{ij} D_{ij} \quad (6.17.5)$$

where we recall W_{ij} (the spin tensor) is the antisymmetric part of $\partial v_i/\partial x_j$ and $D_{ij}W_{ij} = 0$. Thus,

$$P_s = 2\mu D_{ij}D_{ij} = 2\mu(D_{11}^2 + D_{22}^2 + D_{33}^2 + 2D_{12}^2 + 2D_{13}^2 + 2D_{23}^2). \quad (6.17.6)$$

This is work per unit volume done to change the shape, and this part of the work accumulates with time, regardless of how D_{ij} vary with time (P_s is always positive and is zero only for rigid body motions where $D_{ij} = 0$). Thus, the function

$$\Phi_{inc} = 2\mu D_{ij}D_{ij} = 2\mu(D_{11}^2 + D_{22}^2 + D_{33}^2 + 2D_{12}^2 + 2D_{13}^2 + 2D_{23}^2) \quad (6.17.7)$$

is known as the dissipation function for an incompressible Newtonian fluid. It represents the rate at which work is converted into heat.

B. Newtonian Compressible Fluid

For this case, we have, with Δ denoting $\partial v_i/\partial x_i$,

$$T_{ij} \frac{\partial v_i}{\partial x_j} = (-p\delta_{ij} + \lambda\Delta\delta_{ij} + 2\mu D_{ij}) \frac{\partial v_i}{\partial x_j} = -p\Delta + \lambda\Delta^2 + \Phi_{inc} \equiv -p\Delta + \Phi, \quad (6.17.8)$$

where

$$\Phi = \lambda(D_{11} + D_{22} + D_{33})^2 + \Phi_{inc} \quad (6.17.9)$$

is the dissipation function for a compressible Newtonian fluid. We leave it as an exercise (see Problem 6.43) to show that the dissipation function Φ can be written

$$\begin{aligned} \Phi = & \left(\lambda + \frac{2\mu}{3} \right) (D_{11} + D_{22} + D_{33})^2 \\ & + \frac{2\mu}{3} \left[(D_{11} - D_{22})^2 + (D_{11} - D_{33})^2 + (D_{22} - D_{33})^2 \right] + 4\mu(D_{12}^2 + D_{13}^2 + D_{23}^2). \end{aligned} \quad (6.17.10)$$

Example 6.17.1

For the simple shearing flow with

$$v_1 = kx_2, \quad v_2 = v_3 = 0,$$

find the rate at which work is converted into heat if the liquid inside the plates is water with $\mu = 2 \times 10^{-5} \text{ lb} \cdot \text{s}/\text{ft}^2 (0.958 \text{ mPa} \cdot \text{s})$ and $k = 1 \text{ s}^{-1}$.

Solution

Since the only nonzero component of the rate of deformation tensor is

$$D_{12} = k/2,$$

therefore, from Eq. (6.17.7),

$$\Phi_{inc} = 4\mu D_{12}^2 = \mu k^2 = 2 \times 10^{-5} (1) = 2 \times 10^{-5} (\text{ft} \cdot \text{lb}) / (\text{ft}^3 \cdot \text{s}) \left[0.958 \times 10^{-3} (\text{N} \cdot \text{m}) / (\text{m}^3 \cdot \text{s}) \right].$$

6.18 ENERGY EQUATION FOR A NEWTONIAN FLUID

In Section 4.15 of Chapter 4, we derived the energy equation for a continuum to be [see Eq. (4.15.4)]

$$\rho \frac{Du}{Dt} = T_{ij} \frac{\partial v_i}{\partial x_j} - \frac{\partial q_i}{\partial x_i} + \rho q_s, \quad (6.18.1)$$

where u is the internal energy per unit mass, ρ is density, q_i is the component of heat flux vector, and q_s is the heat supply due to external sources.

If the only heat flow taking place is that due to conduction governed by Fourier's law $\mathbf{q} = -\kappa \nabla \Theta$, where Θ is the temperature, then Eq. (6.18.1) becomes, assuming a constant coefficient of thermoconductivity κ ,

$$\rho \frac{Du}{Dt} = T_{ij} \frac{\partial v_i}{\partial x_j} + \kappa \frac{\partial^2 \Theta}{\partial x_j \partial x_j}. \quad (6.18.2)$$

For an incompressible Newtonian fluid, if it is assumed that the internal energy per unit mass is given by $c\Theta$, where c is the specific heat, then Eq. (6.18.2) becomes

$$\rho c \frac{D\Theta}{Dt} = \Phi_{inc} + \kappa \frac{\partial^2 \Theta}{\partial x_j \partial x_j}, \quad (6.18.3)$$

where, from Eq. (6.17.7), $\Phi_{inc} = 2\mu(D_{11}^2 + D_{22}^2 + D_{33}^2 + 2D_{12}^2 + 2D_{13}^2 + 2D_{23}^2)$ representing the heat generated through viscous forces.

There are many situations in which the heat generated through viscous action is very small compared with that arising from the heat conduction from the boundaries, in which case, Eq. (6.18.3) simplifies to

$$\frac{D\Theta}{Dt} = \alpha \frac{\partial^2 \Theta}{\partial x_j \partial x_j}, \quad (6.18.4)$$

where $\alpha = \kappa/\rho c$ is known as the thermal diffusivity.

Example 6.18.1

The plane Couette flow is given by the following velocity distribution

$$v_1 = kx_2, \quad v_2 = 0, \quad v_3 = 0.$$

If the temperature at the lower plate is kept at Θ_ℓ and the upper plate at Θ_u , find the steady-state temperature distribution.

Solution

We seek a temperature distribution that depends only on x_2 . From Eq. (6.18.3), we have, since $D_{12} = k/2$,

$$0 = \mu k^2 + \kappa \frac{d^2 \Theta}{dx_2^2}.$$

Thus,

$$\frac{d^2 \Theta}{dx_2^2} = -\frac{\mu k^2}{\kappa},$$

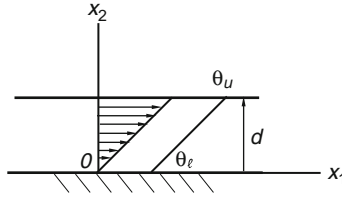

FIGURE 6.18-1

from which

$$\Theta = -\frac{\mu k^2}{2\kappa} x_2^2 + \left(\frac{\Theta_u - \Theta_t}{d} + \frac{\mu k^2 d}{2\kappa} \right) x_2 + \Theta_t.$$

6.19 VORTICITY VECTOR

We recall from Chapter 3, Section 3.13, that the antisymmetric part of the velocity gradient $(\nabla \mathbf{v})$ is defined as the spin tensor \mathbf{W} [see Eq. (3.13.3)]. Being antisymmetric, the tensor \mathbf{W} is equivalent to a vector $\boldsymbol{\omega}$ in the sense that $\mathbf{W}\mathbf{x} = \boldsymbol{\omega} \times \mathbf{x}$ (see Sections 2.21 and 3.14). In fact [see Eq. (3.14.2)],

$$\boldsymbol{\omega} = -(W_{23}\mathbf{e}_1 + W_{31}\mathbf{e}_2 + W_{12}\mathbf{e}_3). \quad (6.19.1)$$

Since [see Eq. (3.12.6)],

$$\frac{D}{Dt}(\mathbf{dx}) = (\nabla \mathbf{v})\mathbf{dx} = \mathbf{D}\mathbf{dx} + \mathbf{W}\mathbf{dx} = \mathbf{D}\mathbf{dx} + \boldsymbol{\omega} \times \mathbf{dx}, \quad (6.19.2)$$

the vector $\boldsymbol{\omega}$ is the angular velocity vector of that part of the motion, representing the rigid body rotation in the infinitesimal neighborhood of a material point. Furthermore, we will show that $\boldsymbol{\omega}$ is the angular velocity vector of the principal axes of the rate of deformation tensor \mathbf{D} . That is, we will show that if \mathbf{n} is a unit vector in a principal direction of \mathbf{D} , then

$$\frac{D\mathbf{n}}{Dt} = \mathbf{W}\mathbf{n} = \boldsymbol{\omega} \times \mathbf{n}. \quad (6.19.3)$$

Let \mathbf{dx} be a material element in the direction of \mathbf{n} at time t ; we have

$$\mathbf{n} = \frac{d\mathbf{x}}{ds}, \quad (6.19.4)$$

where ds is the length of \mathbf{dx} . Taking the material derivative of the preceding equation, we have

$$\frac{D\mathbf{n}}{Dt} = \frac{D}{Dt} \left(\frac{d\mathbf{x}}{ds} \right) = \frac{1}{ds} \left(\frac{D}{Dt} d\mathbf{x} \right) - \frac{1}{ds^2} \left(\frac{D}{Dt} ds \right) d\mathbf{x}. \quad (6.19.5)$$

But, from Eq. (3.13.12) of Chapter 3,

$$\frac{1}{ds} \left(\frac{D}{Dt} ds \right) = \mathbf{n} \cdot \mathbf{D}\mathbf{n}. \quad (6.19.6)$$

Using Eqs. (6.19.2), (6.19.4), and (6.19.6), Eq. (6.19.5) becomes

$$\frac{D\mathbf{n}}{Dt} = (\mathbf{D} + \mathbf{W})\mathbf{n} - (\mathbf{n} \cdot \mathbf{D}\mathbf{n})\mathbf{n} = \mathbf{W}\mathbf{n} + \mathbf{D}\mathbf{n} - (\mathbf{n} \cdot \mathbf{D}\mathbf{n})\mathbf{n}. \quad (6.19.7)$$

Now, since $\mathbf{D}\mathbf{n} = \lambda\mathbf{n}$ and $\mathbf{n} \cdot \mathbf{D}\mathbf{n} = \lambda$, therefore, $\mathbf{D}\mathbf{n} - (\mathbf{n} \cdot \mathbf{D}\mathbf{n})\mathbf{n} = 0$ so that Eq. (6.19.7) becomes

$$\frac{D\mathbf{n}}{Dt} = \mathbf{W}\mathbf{n},$$

which is Eq. (6.19.3), and which states that the material elements that are in the principal directions of \mathbf{D} rotate with angular velocity $\boldsymbol{\omega}$ while at the same time changing their lengths.

In rectangular coordinates,

$$\boldsymbol{\omega} = \frac{1}{2} \left(\frac{\partial v_3}{\partial x_2} - \frac{\partial v_2}{\partial x_3} \right) \mathbf{e}_1 + \frac{1}{2} \left(\frac{\partial v_1}{\partial x_3} - \frac{\partial v_3}{\partial x_1} \right) \mathbf{e}_2 + \frac{1}{2} \left(\frac{\partial v_2}{\partial x_1} - \frac{\partial v_1}{\partial x_2} \right) \mathbf{e}_3. \quad (6.19.8)$$

Conventionally, the factor $\frac{1}{2}$ is dropped and one defines the so-called *vorticity vector* $\boldsymbol{\zeta}$,

$$\boldsymbol{\zeta} = 2\boldsymbol{\omega} = \left(\frac{\partial v_3}{\partial x_2} - \frac{\partial v_2}{\partial x_3} \right) \mathbf{e}_1 + \left(\frac{\partial v_1}{\partial x_3} - \frac{\partial v_3}{\partial x_1} \right) \mathbf{e}_2 + \left(\frac{\partial v_2}{\partial x_1} - \frac{\partial v_1}{\partial x_2} \right) \mathbf{e}_3. \quad (6.19.9)$$

The tensor $2\mathbf{W}$ (where \mathbf{W} is the spin tensor) is known as the *vorticity tensor*.

In indicial notation, the Cartesian components of $\boldsymbol{\zeta}$ are

$$\zeta_i = \varepsilon_{ijk} \frac{\partial v_k}{\partial x_j}, \quad (6.19.10)$$

or, equivalently,

$$\frac{\partial v_i}{\partial x_j} - \frac{\partial v_j}{\partial x_i} = -\varepsilon_{kij} \zeta_k, \quad (6.19.11)$$

and in direct notation,

$$\boldsymbol{\zeta} = \text{curl } \mathbf{v}. \quad (6.19.12)$$

In cylindrical coordinates (r, θ, z) ,

$$\boldsymbol{\zeta} = \left(\frac{1}{r} \frac{\partial v_z}{\partial \theta} - \frac{\partial v_\theta}{\partial z} \right) \mathbf{e}_r + \left(\frac{\partial v_r}{\partial z} - \frac{\partial v_z}{\partial r} \right) \mathbf{e}_\theta + \left(\frac{\partial v_\theta}{\partial r} + \frac{v_\theta}{r} - \frac{1}{r} \frac{\partial v_r}{\partial \theta} \right) \mathbf{e}_z, \quad (6.19.13)$$

and in spherical coordinates (r, θ, ϕ) ,

$$\begin{aligned} \boldsymbol{\zeta} = & \left\{ \frac{v_\phi \cot \theta}{r} + \frac{1}{r} \frac{\partial v_\phi}{\partial \theta} - \frac{1}{r \sin \theta} \frac{\partial v_\theta}{\partial \phi} \right\} \mathbf{e}_r + \left\{ \frac{1}{r \sin \theta} \frac{\partial v_r}{\partial \phi} - \frac{1}{r} \frac{\partial (rv_\phi)}{\partial r} \right\} \mathbf{e}_\theta \\ & + \left\{ \frac{1}{r} \frac{\partial (rv_\theta)}{\partial r} - \frac{1}{r} \frac{\partial v_r}{\partial \theta} \right\} \mathbf{e}_\phi. \end{aligned} \quad (6.19.14)$$

Example 6.19.1

Find the vorticity vector for the simple shearing flow:

$$v_1 = kx_2, \quad v_2 = 0, \quad v_3 = 0.$$

Solution

We have

$$\zeta_1 = \left(\frac{\partial v_3}{\partial x_2} - \frac{\partial v_2}{\partial x_3} \right) = 0, \quad \zeta_2 = \left(\frac{\partial v_1}{\partial x_3} - \frac{\partial v_3}{\partial x_1} \right) = 0, \quad \zeta_3 = \left(\frac{\partial v_2}{\partial x_1} - \frac{\partial v_1}{\partial x_2} \right) = -k.$$

Thus,

$$\boldsymbol{\zeta} = -k\mathbf{e}_3.$$

We see that the angular velocity vector ($=\boldsymbol{\zeta}/2$) is normal to the x_1x_2 plane, and the minus sign simply means that the spinning is clockwise, looking from the positive side of x_3 .

Example 6.19.2

Find the distribution of the vorticity vector in the Couette flow discussed in Section 6.15.

Solution

With $v_r = v_z = 0$ and

$$v_\theta = Ar + B/r,$$

it is clear that the only nonzero vorticity component is in the z direction. From Eq. (6.19.13),

$$\zeta_z = \frac{dv_\theta}{dr} + \frac{v_\theta}{r} = A - \frac{B}{r^2} + A + \frac{B}{r^2} = 2A.$$

Thus (see Section 6.15),

$$\zeta_z = 2 \frac{\Omega_2 r_2^2 - \Omega_1 r_1^2}{r_2^2 - r_1^2}.$$

6.20 IRROTATIONAL FLOW

If the vorticity vector (or equivalently, the vorticity tensor) corresponding to a velocity field is zero in some region and for some time interval, the flow is called *irrotational* in that region and in that time interval.

Let $\varphi(x_1, x_2, x_3, t)$ be a scalar function and let the velocity components be derived from φ according to the following equations:

$$v_1 = -\frac{\partial \varphi}{\partial x_1}, \quad v_2 = -\frac{\partial \varphi}{\partial x_2}, \quad v_3 = -\frac{\partial \varphi}{\partial x_3}, \quad \text{i.e.,} \quad v_i = -\frac{\partial \varphi}{\partial x_i}. \quad (6.20.1)$$

Then the vorticity components are all zero. Indeed,

$$\zeta_1 = \frac{\partial v_3}{\partial x_2} - \frac{\partial v_2}{\partial x_3} = -\frac{\partial^2 \varphi}{\partial x_2 \partial x_3} + \frac{\partial^2 \varphi}{\partial x_3 \partial x_2} = 0 \quad (6.20.2)$$

and similarly, $\zeta_2 = \zeta_3 = 0$. That is, any scalar function $\varphi(x_1, x_2, x_3)$ defines an irrotational flow field through Eqs. (6.20.1). Obviously, not all arbitrary functions φ of x_1, x_2, x_3 and t will give rise to velocity fields that are physically possible. For one thing, the equation of continuity, expressing the principle of conservation of mass, must be satisfied. For an incompressible fluid, the equation of continuity reads:

$$\frac{\partial v_i}{\partial x_i} = 0. \quad (6.20.3)$$

Combining Eq. (6.20.1) with Eq. (6.20.3), we obtain the Laplacian equation for φ :

$$\frac{\partial^2 \varphi}{\partial x_j \partial x_j} = 0. \quad (6.20.4)$$

In the next two sections, we discuss the conditions under which irrotational flows are dynamically possible for an inviscid fluid and a viscous fluid.

6.21 IRROTATIONAL FLOW OF AN INVISCID INCOMPRESSIBLE FLUID OF HOMOGENEOUS DENSITY

An inviscid fluid is defined by the constitutive equation

$$T_{ij} = -p\delta_{ij}, \quad (6.21.1)$$

obtained by setting the viscosity $\mu = 0$ in the constitutive equation for a Newtonian viscous fluid.

The equations of motion for an inviscid fluid are

$$\rho \left(\frac{\partial v_i}{\partial t} + v_j \frac{\partial v_i}{\partial x_j} \right) = -\frac{\partial p}{\partial x_i} + \rho B_i. \quad (6.21.2)$$

Equation (6.21.2) is known as the *Euler's equation of motion*. We now show that irrotational flows are always dynamically possible for an inviscid, incompressible fluid with homogeneous density, provided that the body forces are conservative, that is, they are derivable from a potential by the formulas

$$B_i = -\frac{\partial \Omega}{\partial x_i}. \quad (6.21.3)$$

For example, in the case of gravity force, with the x_3 -axis pointing vertically upward,

$$\Omega = gx_3, \quad (6.21.4)$$

so that

$$B_1 = 0, \quad B_2 = 0, \quad B_3 = -g. \quad (6.21.5)$$

Using Eq. (6.21.3) and noting that $\rho = \text{constant}$ for a homogeneous fluid, Eq. (6.21.2) can be written as

$$\frac{\partial v_i}{\partial t} + v_j \frac{\partial v_i}{\partial x_j} = -\frac{\partial}{\partial x_i} \left(\frac{p}{\rho} + \Omega \right). \quad (6.21.6)$$

For an irrotational flow,

$$\frac{\partial v_i}{\partial x_j} = \frac{\partial v_j}{\partial x_i}, \quad (6.21.7)$$

so that

$$v_j \frac{\partial v_i}{\partial x_j} = v_j \frac{\partial v_j}{\partial x_i} = \frac{1}{2} \frac{\partial}{\partial x_i} (v_j v_j) = \frac{1}{2} \frac{\partial v^2}{\partial x_i}, \quad (6.21.8)$$

where $v^2 = v_1^2 + v_2^2 + v_3^2$ is the square of the speed. Therefore, Eq. (6.21.6) becomes

$$\frac{\partial}{\partial x_i} \left(-\frac{\partial \varphi}{\partial t} + \frac{v^2}{2} + \frac{p}{\rho} + \Omega \right) = 0. \quad (6.21.9)$$

Thus,

$$-\frac{\partial \varphi}{\partial t} + \frac{v^2}{2} + \frac{p}{\rho} + \Omega = f(t). \quad (6.21.10)$$

If the flow is also steady, then we have

$$\frac{v^2}{2} + \frac{p}{\rho} + \Omega = C = \text{constant}. \quad (6.21.11)$$

Equation (6.21.10) and the special case Eq. (6.21.11) are known as the *Bernoulli's equations*. In addition to being a very useful formula in problems where the effect of viscosity can be neglected, the preceding derivation of the formula shows that irrotational flows are always dynamically possible under the conditions stated earlier (constant density and conservative body forces). Under those conditions, for whatever function φ , so long as $v_i = -\partial\varphi/\partial x_i$ and $\nabla^2\varphi = 0$, the dynamic equations of motion can always be integrated to give Bernoulli's equation, from which the pressure distribution is obtained, corresponding to which the equations of motion are satisfied.

Example 6.21.1

Given $\varphi = x_1^3 - 3x_1x_2^2$. (a) Show that φ satisfies the Laplace equation. (b) Find the irrotational velocity field. (c) Find the pressure distribution for an incompressible homogeneous fluid, if $\Omega = gx_3$ and $p = p_0$ at $(0, 0, 0)$, and (d) if the plane $x_2 = 0$ is a solid boundary, find the tangential component of velocity on the plane.

Solution

$$(a) \frac{\partial^2 \varphi}{\partial x_1^2} + \frac{\partial^2 \varphi}{\partial x_2^2} + \frac{\partial^2 \varphi}{\partial x_3^2} = 6x_1 - 6x_1 = 0.$$

$$(b) v_1 = -\frac{\partial \varphi}{\partial x_1} = -3x_1^2 + 3x_2^2, \quad v_2 = -\frac{\partial \varphi}{\partial x_2} = 6x_1x_2, \quad v_3 = 0.$$

(c) At $(0, 0, 0)$, $v_1 = 0$, $v_2 = 0$, $v_3 = 0$, $p = p_0$, $\Omega = 0$; therefore, from the Bernoulli's equation, Eq. (6.21.11), $C = p_0/\rho$.

Thus, $\frac{v^2}{2} + \frac{p}{\rho} + \Omega = \frac{p_0}{\rho}$ so that $p = p_0 - \frac{\rho}{2}(v_1^2 + v_2^2) - \rho gx_3$, or $p = p_0 - \frac{\rho}{2}[9(x_2^2 - x_1^2)^2 + 36x_1^2x_2^2] - \rho gx_3$.

(d) On the plane $x_2 = 0$, $v_1 = -3x_1^2$, $v_2 = 0$, $v_3 = 0$. Now, $v_2 = 0$ means that the normal components of velocity are zero on the plane, which is what it should be if $x_2 = 0$ is a solid fixed boundary. Since $v_1 = -3x_1^2$, the tangential components of velocity are not zero on the plane, that is, the fluid slips on the boundary. In inviscid fluid theory, consistent with the assumption of zero viscosity, the slipping of fluid on a solid boundary is allowed. The next section further discusses this point.

Example 6.21.2

A liquid is being drained through a small opening as shown in Figure 6.21-1. Neglect viscosity and assume that the falling of the free surface is so slow that the flow can be treated as a steady one. Find the exit speed of the liquid jet as a function of h .

Solution

For a point on the free surface such as the point A , $p = p_0$, $v \approx 0$ and $z = h$. For a point B on the exiting jet, its dimension is assumed to be much smaller than h so that $z = 0$ and $p = p_0$. Therefore, from Eq. (6.21.11),

$$\frac{v^2}{2} + \frac{p_0}{\rho} = \frac{p_0}{\rho} + gh,$$

from which,

$$v = \sqrt{2gh}. \quad (6.21.12)$$

This is the well-known *Torricelli's formula*.

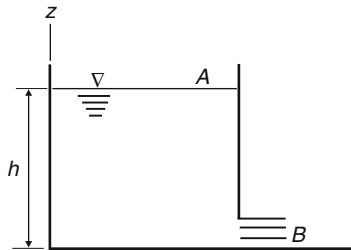

FIGURE 6.21-1

6.22 IRROTATIONAL FLOWS AS SOLUTIONS OF NAVIER-STOKES EQUATION

For an incompressible Newtonian fluid, the equations of motion are the Navier-Stokes equations:

$$\frac{\partial v_i}{\partial t} + v_j \frac{\partial v_i}{\partial x_j} = -\frac{1}{\rho} \frac{\partial p}{\partial x_i} + \frac{\mu}{\rho} \frac{\partial^2 v_i}{\partial x_j \partial x_j} + B_i. \quad (6.22.1)$$

For irrotational flow,

$$v_i = -\frac{\partial \varphi}{\partial x_i}, \quad (6.22.2)$$

so that

$$\frac{\partial^2 v_i}{\partial x_j \partial x_j} = -\frac{\partial^2}{\partial x_j \partial x_j} \left(\frac{\partial \varphi}{\partial x_i} \right) = -\frac{\partial}{\partial x_i} \left(\frac{\partial^2 \varphi}{\partial x_j \partial x_j} \right) = 0. \quad (6.22.3)$$

where we have made use of Eq. (6.20.4). Therefore, the terms involving viscosity in the Navier-Stokes equation (6.22.1) drop out in the case of irrotational flows so that the equations take the same form as the Euler's equation for an inviscid fluid. Thus, *if the viscous fluid has homogeneous density and if the body forces are*

conservative (i.e., $B_i = \partial\Omega/\partial x_i$), the results of the last section show that irrotational flows are also dynamically possible for a viscous fluid. However, in any physical problems, there are always solid boundaries. A viscous fluid adheres to the boundary so that both the tangential and the normal components of the fluid velocity at the boundary should be those of the boundary. This means that both velocity components at the boundary are to be prescribed. For example, if $y = 0$ is a solid boundary at rest, then we have, at $y = 0$, $v_x = v_z = 0$ (i.e., tangential components are zero) and $v_y = 0$ (i.e., the normal component is zero). For irrotational flow with potential function φ , these conditions become $\varphi = \text{constant}$ and $\partial\varphi/\partial y = 0$ at $y = 0$. But it is known from the potential theory that in general there does not exist a solution of the Laplace equation satisfying both $\varphi = \text{constant}$ and $\nabla\varphi \cdot \mathbf{n} = \partial\varphi/\partial n = 0$ (\mathbf{n} is normal to the boundary) on the boundary. Therefore, unless the motion of solid boundaries happens to be consistent with the requirements of irrotationality, vorticity will be generated on the boundary and diffuse into the flow field in accordance with the vorticity equations (to be derived in the next section). However, in certain problems under suitable conditions, the vorticity generated by the solid boundaries is confined to a thin layer of fluid in the vicinity of the boundary so that outside the layer, the flow is irrotational if it originates from a state of irrotationality. We shall have more to say about this topic in the next two sections.

Example 6.22.1

For the Couette flow of a viscous fluid between two coaxial infinitely long cylinders, how should the ratio of the angular velocities of the two cylinders be so that the flow is irrotational?

Solution

The only nonzero vorticity component in the Couette flow is (see Example 6.19.2)

$$\zeta_z = 2 \frac{\Omega_2 r_2^2 - \Omega_1 r_1^2}{r_2^2 - r_1^2}, \quad (6.22.4)$$

where Ω_i denotes the angular velocities. If $\Omega_2 r_2^2 - \Omega_1 r_1^2 = 0$, the flow is irrotational. Thus,

$$\frac{\Omega_2}{\Omega_1} = \frac{r_1^2}{r_2^2}. \quad (6.22.5)$$

It should be noted that even though the viscous terms drop out from the Navier-Stokes equations in the case of irrotational flow, it does not mean that there is no viscous dissipation in an irrotational flow of a viscous fluid. In fact, so long as there is a nonzero rate of deformation component, there is viscous dissipation [given by Eq. (6.17.7)] and the rate of work done to maintain the irrotational flow exactly compensates the viscous dissipation.

6.23 VORTICITY TRANSPORT EQUATION FOR INCOMPRESSIBLE VISCOUS FLUID WITH A CONSTANT DENSITY

In this section, we derive the equation governing the vorticity vector for an incompressible homogeneous ($\rho = \text{constant}$) viscous fluid. Assuming that the body force is derivable from a potential Ω , i.e., $B_i = -\partial\Omega/\partial x_i$, the Navier-Stokes equation can be written

$$\frac{\partial v_i}{\partial t} + v_j \frac{\partial v_i}{\partial x_j} = -\frac{\partial}{\partial x_i} \left(\frac{p}{\rho} + \Omega \right) + \nu \frac{\partial^2 v_i}{\partial x_j \partial x_j}, \quad (6.23.1)$$

where $\nu \equiv \mu/\rho \equiv$ kinematic viscosity. The vorticity components are given by

$$\zeta_m = \varepsilon_{mni} \frac{\partial v_i}{\partial x_n}. \quad (6.23.2)$$

It can be shown (see the following example) that in terms of vorticity components ζ_m , the Navier-Stokes equation takes the form of

$$\frac{D\zeta_m}{Dt} = \frac{\partial v_m}{\partial x_n} \zeta_n + \nu \frac{\partial^2 \zeta_m}{\partial x_j \partial x_j}, \quad (6.23.3)$$

or, in direct notation,

$$\frac{D\boldsymbol{\zeta}}{Dt} = (\nabla \mathbf{v})\boldsymbol{\zeta} + \nu \nabla^2 \boldsymbol{\zeta}. \quad (6.23.4)$$

Example 6.23.1

Show:

- (a) $\varepsilon_{mni} \frac{\partial v_j}{\partial x_n} \frac{\partial v_j}{\partial x_i} = 0$ and $\varepsilon_{mni} \frac{\partial^2 A}{\partial x_n \partial x_i} = 0$ for any $A(x_i)$.
- (b) For an incompressible fluid, $\varepsilon_{mni} \varepsilon_{pji} \frac{\partial v_j}{\partial x_n} \zeta_p = -\frac{\partial v_m}{\partial x_n} \zeta_n$.
- (c) $\varepsilon_{mni} \frac{\partial v_j}{\partial x_n} \frac{\partial v_j}{\partial x_i} = -\frac{\partial v_m}{\partial x_n} \zeta_n$.
- (d) $\frac{D\zeta_m}{Dt} = \frac{\partial v_m}{\partial x_n} \zeta_n + \nu \frac{\partial^2 \zeta_m}{\partial x_j \partial x_j}$ [Eq. (6.23.3)].

Solution

- (a) Changing the dummy index from n to i and i to n , we obtain

$$\varepsilon_{mni} \frac{\partial v_j}{\partial x_n} \frac{\partial v_j}{\partial x_i} = \varepsilon_{min} \frac{\partial v_j}{\partial x_i} \frac{\partial v_j}{\partial x_n} = -\varepsilon_{mni} \frac{\partial v_j}{\partial x_i} \frac{\partial v_j}{\partial x_n}.$$

Therefore,

$$\varepsilon_{mni} \frac{\partial v_j}{\partial x_n} \frac{\partial v_j}{\partial x_i} = 0.$$

Similarly,

$$\varepsilon_{mni} \frac{\partial^2 A}{\partial x_n \partial x_i} = \varepsilon_{min} \frac{\partial^2 A}{\partial x_i \partial x_n} = 0.$$

- (b) Since $\varepsilon_{mni} \varepsilon_{pji} = \delta_{mp} \delta_{nj} - \delta_{mj} \delta_{np}$ (see Prob. 2.12),

$$\varepsilon_{mni} \varepsilon_{pji} \frac{\partial v_j}{\partial x_n} \zeta_p = (\delta_{mp} \delta_{nj} - \delta_{mj} \delta_{np}) \frac{\partial v_j}{\partial x_n} \zeta_p = \frac{\partial v_j}{\partial x_j} \zeta_m - \frac{\partial v_m}{\partial x_n} \zeta_n = -\frac{\partial v_m}{\partial x_n} \zeta_n,$$

where we have used the equation $\frac{\partial v_j}{\partial x_j} = 0$ for an incompressible fluid.

- (c) From $\frac{\partial v_i}{\partial x_j} - \frac{\partial v_j}{\partial x_i} = -\varepsilon_{kij} \zeta_k$ [see Eq. (6.19.11)], we have

$$\frac{\partial v_i}{\partial x_j} = \frac{\partial v_j}{\partial x_i} - \varepsilon_{kij} \zeta_k = \frac{\partial v_j}{\partial x_i} - \varepsilon_{pij} \zeta_p.$$

Multiplying this last equation by $\varepsilon_{mni} \frac{\partial v_j}{\partial x_n}$, we have

$$\varepsilon_{mni} \frac{\partial v_j}{\partial x_n} \frac{\partial v_i}{\partial x_j} = \varepsilon_{mni} \frac{\partial v_j}{\partial x_n} \frac{\partial v_i}{\partial x_j} - \varepsilon_{mni} \varepsilon_{pij} \frac{\partial v_j}{\partial x_n} \zeta_p = \varepsilon_{mni} \frac{\partial v_j}{\partial x_n} \frac{\partial v_i}{\partial x_j} + \varepsilon_{mni} \varepsilon_{pji} \frac{\partial v_j}{\partial x_n} \zeta_p.$$

Using the results in (a) and (b), we have

$$\varepsilon_{mni} \frac{\partial v_j}{\partial x_n} \frac{\partial v_i}{\partial x_j} = -\frac{\partial v_m}{\partial x_n} \zeta_n.$$

(d) Operating $\left(\varepsilon_{mni} \frac{\partial}{\partial x_n} \right)$ on the equation $\frac{\partial v_i}{\partial t} + v_j \frac{\partial v_i}{\partial x_j} = -\frac{\partial}{\partial x_i} \left(\frac{p}{\rho} + \Omega \right) + \nu \frac{\partial^2 v_i}{\partial x_j \partial x_j}$, we get

$$\varepsilon_{mni} \frac{\partial}{\partial x_n} \frac{\partial v_i}{\partial t} + \varepsilon_{mni} \frac{\partial}{\partial x_n} v_j \frac{\partial v_i}{\partial x_j} = -\varepsilon_{mni} \frac{\partial^2 A}{\partial x_n \partial x_i} + \varepsilon_{mni} \frac{\partial}{\partial x_n} \nu \frac{\partial^2 v_i}{\partial x_j \partial x_j},$$

where $A = \left(\frac{p}{\rho} + \Omega \right)$ and $\varepsilon_{mni} \frac{\partial^2 A}{\partial x_n \partial x_i} = 0$ [see result in part (a)]. Thus, we have

$$\frac{\partial}{\partial t} \left(\varepsilon_{mni} \frac{\partial v_i}{\partial x_n} \right) + \varepsilon_{mni} \frac{\partial v_j}{\partial x_n} \frac{\partial v_i}{\partial x_j} + \varepsilon_{mni} v_j \frac{\partial^2 v_i}{\partial x_n \partial x_j} = \nu \frac{\partial^2}{\partial x_j \partial x_j} \left(\varepsilon_{mni} \frac{\partial v_i}{\partial x_n} \right).$$

Now, using the result in part (c), the preceding equation becomes

$$\frac{\partial}{\partial t} \left(\varepsilon_{mni} \frac{\partial v_i}{\partial x_n} \right) - \frac{\partial v_m}{\partial x_n} \zeta_n + v_j \frac{\partial}{\partial x_j} \left(\varepsilon_{mni} \frac{\partial v_i}{\partial x_n} \right) = \nu \frac{\partial^2}{\partial x_j \partial x_j} \left(\varepsilon_{mni} \frac{\partial v_i}{\partial x_n} \right).$$

Therefore,

$$\frac{\partial \zeta_m}{\partial t} + v_j \frac{\partial \zeta_m}{\partial x_j} = \frac{\partial v_m}{\partial x_n} \zeta_n + \nu \frac{\partial^2 \zeta_m}{\partial x_j \partial x_j},$$

which is Eq. (6.23.3), or Eq. (6.23.4).

Example 6.23.2

Reduce from Eq. (6.23.4) the vorticity transport equation for the case of two-dimensional flows.

Solution

Let the velocity field be

$$v_1 = v_1(x_1, x_2, t), \quad v_2 = v_2(x_1, x_2, t), \quad v_3 = 0.$$

Then

$$\zeta = \left(\frac{\partial v_3}{\partial x_2} - \frac{\partial v_2}{\partial x_3} \right) \mathbf{e}_1 + \left(\frac{\partial v_1}{\partial x_3} - \frac{\partial v_3}{\partial x_1} \right) \mathbf{e}_2 + \left(\frac{\partial v_2}{\partial x_1} - \frac{\partial v_1}{\partial x_2} \right) \mathbf{e}_3 = \left(\frac{\partial v_2}{\partial x_1} - \frac{\partial v_1}{\partial x_2} \right) \mathbf{e}_3 = \zeta_3 \mathbf{e}_3.$$

Also,

$$[(\nabla \mathbf{v})\boldsymbol{\zeta}] = \begin{bmatrix} \partial v_1/\partial x_1 & \partial v_1/\partial x_2 & 0 \\ \partial v_2/\partial x_1 & \partial v_2/\partial x_2 & 0 \\ 0 & 0 & 0 \end{bmatrix} \begin{bmatrix} 0 \\ 0 \\ \zeta_3 \end{bmatrix} = \begin{bmatrix} 0 \\ 0 \\ 0 \end{bmatrix}.$$

Thus, Eq. (6.23.4) reduces to the scalar equation

$$\frac{D\zeta_3}{Dt} = \nu \nabla^2 \zeta_3. \quad (6.23.5)$$

6.24 CONCEPT OF A BOUNDARY LAYER

In this section we describe, qualitatively, the concept of the viscous boundary layer by means of an analogy. In Example 6.23.2, we derived the vorticity equation for two-dimensional flows of an incompressible viscous fluid to be the following:

$$\frac{D\zeta}{Dt} = \nu \nabla^2 \zeta, \quad (6.24.1)$$

where ζ is the only nonzero vorticity component for the 2-D flow and ν is kinematic viscosity.

In Section 6.18 we saw that, if the heat generated through viscous dissipation is neglected, the equation governing the temperature distribution in the flow field due to heat conduction through the boundaries of a hot body is given by [see Eq. (6.18.4)]

$$\frac{D\Theta}{Dt} = \alpha \nabla^2 \Theta, \quad (6.24.2)$$

where Θ is temperature and α , the thermal diffusivity, is related to conductivity κ , density ρ , and specific heat per unit mass c by the formula $\alpha = \kappa/\rho c$.

Now suppose that we have the problem of a uniform stream flowing past a hot body whose temperature in general varies along the boundary. Let the temperature at large distance from the body be Θ_∞ ; then, defining $\Theta' = \Theta - \Theta_\infty$, we have

$$\frac{D\Theta'}{Dt} = \alpha \nabla^2 \Theta', \quad (6.24.3)$$

where $\Theta' = 0$ at $x^2 + y^2 \rightarrow \infty$. On the other hand, the distribution of vorticity around the body is governed by

$$\frac{D\zeta}{Dt} = \nu \nabla^2 \zeta, \quad (6.24.4)$$

with $\zeta = 0$ at $x^2 + y^2 \rightarrow \infty$. Comparing the preceding two equations, we see that the distribution of vorticity in the flow field, due to its diffusion from the boundary, where it is generated, is much like that of temperature due to the diffusion of heat from the boundary of the hot body.

Now, it is intuitively clear that in the case of the temperature distribution, the influence of the hot temperature of the body in the field depends on the speed of the stream. At very low speed, conduction dominates over the convection of heat so that its influence will extend deep into the fluid in all directions, as shown by the curve C_1 in Figure 6.24-1; whereas at high speed, the heat is convected away by the fluid so rapidly that the region affected by the hot body will be confined to a thin layer in the immediate neighborhood of the body and a tail of heated fluid behind it, as shown by the curve C_2 in the same figure.

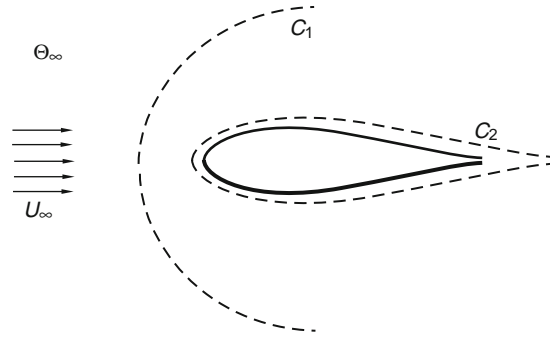

FIGURE 6.24-1

Analogously, the influence of viscosity, which is responsible for the generation of vorticity on the boundary, depends on the speed U_∞ far upstream. At low speed, the influence will be deep into the field in all directions so that essentially the whole flow field has vorticity. On the other hand, at high speed, the effect of viscosity is confined in a thin layer (known as a *boundary layer*) near the body and behind it. Outside the layer, the flow is essentially irrotational. This concept enables one to solve a fluid flow problem by dividing the flow region into an irrotational external flow region and a viscous boundary layer. Such a method simplifies considerably the complexity of the mathematical problem involving the full Navier-Stokes equations. We shall not go into the methods of solution and of the matching of the regions, since they belong to the boundary layer theory.

6.25 COMPRESSIBLE NEWTONIAN FLUID

For a compressible fluid to be consistent with the state of stress corresponding to the state of rest and to be consistent with the definition that p is not to depend explicitly on any kinematic quantities when in motion, we shall regard p as having the same value as the thermodynamic equilibrium pressure. That is, for a particular density ρ and temperature Θ , the pressure p is assumed to be determined by the equilibrium equation of state

$$p = p(\rho, \Theta). \quad (6.25.1)$$

For example, for an ideal gas, $p = R\rho\Theta$, where R is the gas constant. Thus,

$$T_{ij} = -p(\rho, \Theta)\delta_{ij} + \lambda\Delta\delta_{ij} + 2\mu D_{ij}, \quad (6.25.2)$$

and

$$T_{ii}/3 = -p + k\Delta, \quad (6.25.3)$$

where Δ is the rate of dilatation given by

$$\Delta = \frac{\partial v_i}{\partial x_i}, \quad (6.25.4)$$

and k is bulk viscosity given by

$$k = \lambda + (2/3)\mu. \quad (6.25.5)$$

We see that in general all stress components, including the normal stress components, depend on the motion through the terms involving the rate of deformation. In particular, the mean normal stress $T_{ii}/3$

depends not only on p but also on the rate of dilatation. However, if either the bulk viscosity k is zero or the rate of dilatation is zero (e.g., incompressible fluid), then the mean normal stress is the same as p . The assumption that $k = 0$ is known as the *Stokes assumption*, which is known to be valid for monatomic gases.

In terms of μ and k , the constitutive equation can be written

$$T_{ij} = -p\delta_{ij} - \frac{2}{3}\mu\Delta\delta_{ij} + 2\mu D_{ij} + k\Delta\delta_{ij} \quad (6.25.6)$$

and the equations of motion become (assuming constant μ and k)

$$\rho \frac{Dv_i}{Dt} = -\rho B_i - \frac{\partial p}{\partial x_i} + \frac{\mu}{3} \frac{\partial}{\partial x_i} \left(\frac{\partial v_j}{\partial x_j} \right) + \mu \frac{\partial^2 v_i}{\partial x_j \partial x_j} + k \frac{\partial}{\partial x_i} \left(\frac{\partial v_j}{\partial x_j} \right). \quad (6.25.7)$$

We also have the equation of continuity [see Eq. (3.15.3)]

$$\frac{D\rho}{Dt} + \rho \frac{\partial v_j}{\partial x_j} = 0 \quad (6.25.8)$$

and the energy equation [see Eq. (6.18.2)]

$$\rho \frac{Du}{Dt} = T_{ij} \frac{\partial v_i}{\partial x_j} + \kappa \frac{\partial^2 \Theta}{\partial x_j \partial x_j}, \quad (6.25.9)$$

where the internal energy u depends on ρ and Θ ,

$$u = u(\rho, \Theta). \quad (6.25.10)$$

For example, for ideal gas, with c_v denoting specific heat at constant volume,

$$u = c_v \Theta. \quad (6.25.11)$$

Equations (6.25.1), (6.25.7), (6.25.8), (6.25.9), and (6.25.10) form a system of seven scalar equations for the seven unknowns $v_1, v_2, v_3, p, \rho, \Theta$, and u .

6.26 ENERGY EQUATION IN TERMS OF ENTHALPY

Enthalpy per unit mass is defined as

$$h = u + \frac{p}{\rho}. \quad (6.26.1)$$

The *stagnation enthalpy* is defined by the equation

$$h_o = h + \frac{v^2}{2}. \quad (6.26.2)$$

It can be shown (see Example 6.26.1) that in terms of h_o , the energy equation becomes (in the absence of body forces B_i and heat supply q_s)

$$\frac{Dh_o}{Dt} = \frac{\partial p}{\partial t} + \frac{\partial}{\partial x_j} (T'_{ij} v_i - q_j), \quad (6.26.3)$$

where T'_{ij} is the viscous stress tensor (in $T_{ij} = -p\delta_{ij} + T'_{ij}$) and q_j the heat flux vector.

Example 6.26.1

Show that:

$$(a) \quad -\rho \frac{\partial v_i}{\partial x_i} + \rho \frac{D}{Dt} \left(\frac{\rho}{\rho} \right) - v_i \frac{\partial \rho}{\partial x_i} = \frac{\partial \rho}{\partial t},$$

$$(b) \quad \rho \frac{Du}{Dt} + \rho v_i \frac{Dv_i}{Dt} = \frac{\partial p}{\partial t} - \rho \frac{D}{Dt} \left(\frac{\rho}{\rho} \right) + T'_{ij} \frac{\partial v_i}{\partial x_j} - \frac{\partial q_i}{\partial x_i} + v_i \frac{\partial T'_{ij}}{\partial x_j}, \text{ assuming no heat source, i.e., } q_s = 0,$$

$$(c) \quad \rho \frac{Dh_o}{Dt} = \frac{\partial(T'_{ij} v_i)}{\partial x_j} - \frac{\partial q_i}{\partial x_i} + \frac{\partial p}{\partial t}.$$

Solution

$$(a) \quad -\rho \frac{\partial v_i}{\partial x_i} + \rho \frac{D}{Dt} \left(\frac{\rho}{\rho} \right) - v_i \frac{\partial \rho}{\partial x_i} = -\rho \frac{\partial v_i}{\partial x_i} - \frac{\rho D\rho}{\rho Dt} + \frac{D\rho}{Dt} - v_i \frac{\partial \rho}{\partial x_i} \\ = -\frac{\rho}{\rho} \left(\rho \frac{\partial v_i}{\partial x_i} + \frac{D\rho}{Dt} \right) + \left(\frac{\partial \rho}{\partial t} + v_i \frac{\partial \rho}{\partial x_i} \right) - v_i \frac{\partial \rho}{\partial x_i} = \frac{\partial \rho}{\partial t}.$$

$$(b) \quad \text{From the energy equation } \rho \frac{Du}{Dt} = T'_{ij} \frac{\partial v_i}{\partial x_j} - \frac{\partial q_i}{\partial x_i} \text{ [see Eq. (6.18.1)] and the equation of motion } \rho \frac{Dv_i}{Dt} = \frac{\partial T'_{ij}}{\partial x_j} \text{ [see Eq. (4.7.5)], we have}$$

$$\rho \frac{Du}{Dt} + \rho v_i \frac{Dv_i}{Dt} = \left(T'_{ij} \frac{\partial v_i}{\partial x_j} - \frac{\partial q_i}{\partial x_i} \right) + v_i \frac{\partial T'_{ij}}{\partial x_j} = \left(-\rho \delta_{ij} + T'_{ij} \right) \frac{\partial v_i}{\partial x_j} - \frac{\partial q_i}{\partial x_i} + v_i \frac{\partial(-\rho \delta_{ij} + T'_{ij})}{\partial x_j} \\ = -\rho \frac{\partial v_i}{\partial x_i} + T'_{ij} \frac{\partial v_i}{\partial x_j} - \frac{\partial q_i}{\partial x_i} - v_i \frac{\partial \rho}{\partial x_i} + v_i \frac{\partial T'_{ij}}{\partial x_j} = \left(-\rho \frac{\partial v_i}{\partial x_i} - v_i \frac{\partial \rho}{\partial x_i} \right) + T'_{ij} \frac{\partial v_i}{\partial x_j} - \frac{\partial q_i}{\partial x_i} + v_i \frac{\partial T'_{ij}}{\partial x_j}.$$

Now, using the result in (a), we have

$$\rho \frac{Du}{Dt} + \rho v_i \frac{Dv_i}{Dt} = \frac{\partial p}{\partial t} - \rho \frac{D}{Dt} \left(\frac{\rho}{\rho} \right) + T'_{ij} \frac{\partial v_i}{\partial x_j} - \frac{\partial q_i}{\partial x_i} + v_i \frac{\partial T'_{ij}}{\partial x_j}.$$

$$(c) \quad \rho \frac{Dh_o}{Dt} = \rho \frac{D}{Dt} \left(h + \frac{v^2}{2} \right) = \rho \frac{D}{Dt} \left(u + \frac{\rho}{\rho} + \frac{v_i v_i}{2} \right) = \rho \frac{Du}{Dt} + \rho \frac{D}{Dt} \left(\frac{\rho}{\rho} \right) + \rho v_i \frac{Dv_i}{Dt}.$$

Now, using the result in (b), we have

$$\rho \frac{Dh_o}{Dt} = \frac{\partial p}{\partial t} + T'_{ij} \frac{\partial v_i}{\partial x_j} - \frac{\partial q_i}{\partial x_i} + v_i \frac{\partial T'_{ij}}{\partial x_j} \quad \text{or} \quad \rho \frac{Dh_o}{Dt} = \frac{\partial p}{\partial t} + \frac{\partial(T'_{ij} v_i)}{\partial x_j} - \frac{\partial q_i}{\partial x_i},$$

which is Eq. (6.26.3).

Example 6.26.2

Show that for steady flows of an inviscid, non-heat-conducting fluid, if the flow originates from a homogeneous state, then (a)

$$h + \frac{v^2}{2} = \text{constant}, \quad (6.26.4)$$

and (b) if the fluid is an ideal gas, then

$$\frac{\gamma}{\gamma - 1} \frac{p}{\rho} + \frac{v^2}{2} = \text{constant}, \quad (6.26.5)$$

where $\gamma = c_p/c_v$, the ratio of specific heat.

Solution

- (a) Since the flow is steady, $\partial p/\partial t = 0$. Since the fluid is inviscid and non-heat-conducting, $T'_{ij} = 0$ and $q_i = 0$. Thus, the energy equation (6.26.3) reduces to

$$\frac{Dh_0}{Dt} = 0. \quad (6.26.6)$$

In other words, h_0 is a constant for each particle. But since the flow originates from a homogeneous state,

$$h_0 = h + \frac{v^2}{2} = \frac{p}{\rho} + u + \frac{v^2}{2} = \text{constant} \quad (6.26.7)$$

in the whole flow field.

- (b) For an ideal gas, $p = \rho R\Theta$, $u = c_v\Theta$ and $R = c_p - c_v$, therefore,

$$u = \frac{p}{\rho} \left(\frac{1}{\gamma - 1} \right), \quad (6.26.8)$$

and

$$h_0 = \frac{p}{\rho} \left(\frac{\gamma}{\gamma - 1} \right) + \frac{v^2}{2} = \text{constant}. \quad (6.26.9)$$

6.27 ACOUSTIC WAVE

The propagation of sound can be approximated by considering the propagation of infinitesimal disturbances in a compressible inviscid fluid. For an inviscid fluid, neglecting body forces, the equations of motion are

$$\frac{\partial v_i}{\partial t} + v_j \frac{\partial v_i}{\partial x_j} = - \frac{1}{\rho} \frac{\partial p}{\partial x_i}. \quad (6.27.1)$$

Let us suppose that the fluid is initially at rest with

$$v_i = 0, \quad \rho = \rho_0, \quad p = p_0. \quad (6.27.2)$$

Now suppose that the fluid is perturbed from rest such that

$$v_i = v'_i(\mathbf{x}, t), \quad \rho = \rho_0 + \rho'(\mathbf{x}, t), \quad p = p_0 + p'(\mathbf{x}, t). \quad (6.27.3)$$

Substituting Eqs. (6.27.3) into Eq. (6.27.1), we obtain

$$\frac{\partial v'_i}{\partial t} + v'_j \frac{\partial v'_i}{\partial x_j} = - \frac{1}{\rho_0(1 + \rho'/\rho_0)} \frac{\partial p'}{\partial x_i}. \quad (6.27.4)$$

Since we assumed infinitesimal disturbances, the terms $v'_j(\partial v'_i/\partial x_j)$ are negligible compared to $\partial v'_i/\partial t$ and ρ'/ρ_0 is negligible compared to 1; thus, we obtain the linearized equations of motion

$$\frac{\partial v'_i}{\partial t} = -\frac{1}{\rho_0} \frac{\partial p'}{\partial x_i}. \quad (6.27.5)$$

In a similar manner, we consider the mass conservation equation

$$\frac{\partial \rho'}{\partial t} + v'_j \frac{\partial \rho'}{\partial x_j} + \rho_0(1 + \rho'/\rho_0) \frac{\partial v'_i}{\partial x_i} = 0 \quad (6.27.6)$$

and obtain the linearized equation

$$\frac{\partial v'_i}{\partial x_i} = -\frac{1}{\rho_0} \frac{\partial \rho'}{\partial t}. \quad (6.27.7)$$

Differentiating Eq. (6.27.5) with respect to x_i and Eq. (6.27.7) with respect to t , we eliminate the velocity to obtain

$$\frac{\partial^2 p'}{\partial x_i \partial x_i} = \frac{\partial^2 \rho'}{\partial t^2}. \quad (6.27.8)$$

We further assume that the flow is *barotropic*, i.e., the pressure depends explicitly on density only. That is, $p = p(\rho)$. Expanding $p = p(\rho)$ in a Taylor series about the rest value of pressure p_0 , we have

$$p = p_0 + \left(\frac{dp}{d\rho} \right)_{\rho_0} (\rho - \rho_0) + \dots, \quad (6.27.9)$$

Neglecting the higher-order terms, we have

$$p' = c_0^2 \rho', \quad c_0^2 = \left(\frac{dp}{d\rho} \right)_{\rho_0}. \quad (6.27.10)$$

Thus, for a barotropic flow,

$$c_0^2 \frac{\partial^2 p'}{\partial x_i \partial x_i} = \frac{\partial^2 p'}{\partial t^2} \quad \text{and} \quad c_0^2 \frac{\partial^2 \rho'}{\partial x_i \partial x_i} = \frac{\partial^2 \rho'}{\partial t^2}. \quad (6.27.11)$$

These equations are exactly analogous (for one-dimensional waves) to the elastic wave equations of Chapter 5. Thus, we conclude that the pressure and density disturbances will propagate with a speed $c_0 = \sqrt{(dp/d\rho)_{\rho_0}}$. We call c_0 the *speed of sound* at stagnation; the *local speed of sound* is defined to be

$$c = \sqrt{\frac{dp}{d\rho}}. \quad (6.27.12)$$

When the isentropic relation of p and ρ is used, i.e.,

$$p = \beta \rho^\gamma, \quad (6.27.13)$$

where β is a constant and γ is the ratio of specific heats, the speed of sound becomes

$$c = \sqrt{\gamma \frac{p}{\rho}}. \quad (6.27.14)$$

Example 6.27.1

For simplicity, let p, ρ , and v_i denote disturbances (instead of p', ρ' and v_i').

- (a) Write an expression for a harmonic plane acoustic wave propagating in the \mathbf{e}_1 direction.
- (b) Find the velocity disturbance v_1 .
- (c) Compare $\partial v_i / \partial t$ to the neglected $v_j (\partial v_i / \partial x_j)$.

Solution

$$(a) \quad p = \varepsilon \sin \left[\frac{2\pi}{\ell} (x_1 - c_0 t) \right].$$

(b) Using Eq. (6.27.5), we have

$$\frac{\partial v_1}{\partial t} = -\frac{1}{\rho_0} \frac{\partial p}{\partial x_1} = -\frac{\varepsilon}{\rho_0} \left(\frac{2\pi}{\ell} \right) \cos \left[\frac{2\pi}{\ell} (x_1 - c_0 t) \right],$$

thus, the velocity disturbance is

$$v_1 = \frac{\varepsilon}{\rho_0 c_0} \sin \left[\frac{2\pi}{\ell} (x_1 - c_0 t) \right].$$

(c) For the one-dimensional case, we have the following ratio of amplitudes:

$$\left| \frac{v_1}{\frac{\partial v_1}{\partial t}} \right| = \frac{|v_1| \left(\frac{2\pi \varepsilon}{\ell \rho_0 c_0} \right)}{\frac{\varepsilon}{\rho_0} \left(\frac{2\pi}{\ell} \right)} = \frac{|v_1|}{c_0}.$$

Thus, the approximation is best when the disturbance has velocity that is much smaller than the speed of sound.

Example 6.27.2

Two fluids have a plane interface at $x_1 = 0$. Consider a plane acoustic wave that is normally incident on the interface and determine the amplitudes of the reflected and transmitted waves.

Solution

Let the fluid properties to the left of the interface ($x_1 < 0$) be denoted by ρ_1 and c_1 and to the right ($x_1 > 0$) by ρ_2 and c_2 .

Now let the incident pressure wave propagate to the right be given by

$$p_I = \varepsilon_I \sin \left[\frac{2\pi}{\ell_I} (x_1 - c_1 t) \right], \quad (x_1 \geq 0). \quad (i)$$

This pressure wave results in a reflected wave

$$p_R = \varepsilon_R \sin \left[\frac{2\pi}{\ell_R} (x_1 + c_1 t) \right], \quad (x_1 \leq 0), \quad (ii)$$

and a transmitted wave

$$p_T = \varepsilon_T \sin \left[\frac{2\pi}{\ell_T} (x_1 - c_2 t) \right], \quad (x_1 \geq 0). \quad (iii)$$

On the interface $x_1 = 0$, the pressure on the left fluid exerted by the right fluid is given by $(p_l + p_R)|_{x_1=0}$, whereas the pressure on the right fluid exerted by the left fluid is $(p_T)|_{x_1=0}$. By Newton's third law, we must have

$$(p_l + p_R)|_{x_1=0} = (p_T)|_{x_1=0}. \quad (\text{iv})$$

Thus, Eqs. (i), (ii), and (iii) give

$$\varepsilon_l \sin \frac{2\pi c_1 t}{\ell_l} - \varepsilon_R \sin \frac{2\pi c_1 t}{\ell_R} = \varepsilon_T \sin \frac{2\pi c_2 t}{\ell_T}. \quad (\text{v})$$

This equation will be satisfied at all times if

$$\ell_l = \ell_R = (c_1/c_2)\ell_T \quad (\text{vi})$$

and

$$\varepsilon_l - \varepsilon_R = \varepsilon_T. \quad (\text{vii})$$

In addition, we require that the normal velocity be continuous at all times on the interface $x_1 = 0$ so that $(\partial v_1/\partial t)_{x_1=0}$ is also continuous. Thus, by using Eq. (6.27.5),

$$-\left(\frac{\partial v_1}{\partial t}\right)_{x_1=0} = \frac{1}{\rho_1} \left(\frac{\partial p_l}{\partial x_1} + \frac{\partial p_R}{\partial x_1}\right)_{x_1=0} = \frac{1}{\rho_2} \left(\frac{\partial p_T}{\partial x_1}\right)_{x_1=0}. \quad (\text{viii})$$

Substituting for the pressures, we obtain

$$\frac{1}{\rho_1} \left(\frac{\varepsilon_l}{\ell_l} + \frac{\varepsilon_R}{\ell_R}\right) = \frac{1}{\rho_2} \left(\frac{\varepsilon_T}{\ell_T}\right). \quad (\text{ix})$$

Combining Eqs. (vi), (vii), and (ix), we obtain

$$\varepsilon_T = \left[\frac{2}{1 + (\rho_1 c_1/\rho_2 c_2)}\right] \varepsilon_l, \quad \varepsilon_R = \left[\frac{(\rho_1 c_1/\rho_2 c_2) - 1}{1 + (\rho_1 c_1/\rho_2 c_2)}\right] \varepsilon_l. \quad (\text{x})$$

Note that for the special case $\rho_1 c_1 = \rho_2 c_2$

$$\varepsilon_T = \varepsilon_l, \quad \varepsilon_R = 0. \quad (\text{xi})$$

The product ρc is referred to as the *fluid impedance*. This result shows that if the impedances match, there is no reflection.

6.28 IRROTATIONAL, BAROTROPIC FLOWS OF AN INVISCID COMPRESSIBLE FLUID

Consider an irrotational flow field given by

$$v_i = -\frac{\partial \phi}{\partial x_i}. \quad (6.28.1)$$

To satisfy the mass conservation principle, we must have

$$\frac{\partial \rho}{\partial t} + \left(-\frac{\partial \phi}{\partial x_j} \right) \frac{\partial \rho}{\partial x_j} + \rho \frac{\partial}{\partial x_j} \left(-\frac{\partial \phi}{\partial x_j} \right) = 0. \quad (6.28.2)$$

The equations of motion for an inviscid fluid are the Euler equations

$$\frac{\partial v_i}{\partial t} + v_j \frac{\partial v_i}{\partial x_j} = -\frac{1}{\rho} \frac{\partial p}{\partial x_i} + B_i. \quad (6.28.3)$$

We assume that the flow is *barotropic*, that is, the pressure is an explicit function of density only (such as in isentropic or isothermal flow). Thus, in barotropic flow,

$$p = p(\rho) \quad \text{and} \quad \rho = \rho(p). \quad (6.28.4)$$

Now

$$\frac{\partial}{\partial x_i} \left(\int \frac{1}{\rho} dp \right) = \left[\frac{d}{dp} \left(\int \frac{1}{\rho} dp \right) \right] \frac{\partial p}{\partial x_i} = \frac{1}{\rho} \frac{\partial p}{\partial x_i}. \quad (6.28.5)$$

Therefore, for barotropic flows of an inviscid fluid under conservative body forces (i.e., $B_i = -\partial \Omega / \partial x_i$), the equations of motion can be written:

$$\frac{\partial v_i}{\partial t} + v_j \frac{\partial v_i}{\partial x_j} = -\frac{\partial}{\partial x_i} \left(\int \frac{dp}{\rho} + \Omega \right). \quad (6.28.6)$$

Comparing Eq. (6.28.6) with Eq. (6.21.6), we see immediately that under the conditions stated, irrotational flows are again always dynamically possible. In fact, the integration of Eq. (6.28.6) (in exactly the same way as was done in Section 6.21) gives the following Bernoulli equation:

$$-\frac{\partial \phi}{\partial t} + \int \frac{dp}{\rho} + \frac{v^2}{2} + \Omega = f(t), \quad (6.28.7)$$

which, for steady flow, becomes

$$\int \frac{dp}{\rho} + \frac{v^2}{2} + \Omega = \text{constant}. \quad (6.28.8)$$

For most problems in gas dynamics, the body force is small compared with other forces and is often neglected. We then have

$$\int \frac{dp}{\rho} + \frac{v^2}{2} = \text{constant}. \quad (6.28.9)$$

Example 6.28.1

Show that for steady *isentropic irrotational flows* of an inviscid compressible fluid (body forces neglected)

$$\frac{\gamma}{\gamma - 1} \frac{p}{\rho} + \frac{v^2}{2} = \text{constant}. \quad (6.28.10)$$

Solution

For an isentropic flow $p = \beta \rho^\gamma$, $dp = \beta \gamma \rho^{\gamma-1} d\rho$ so that

$$\int \frac{dp}{\rho} = \beta \gamma \int \rho^{\gamma-2} d\rho = \beta \gamma \frac{\rho^{\gamma-1}}{\gamma-1} = \frac{\gamma}{\gamma-1} \frac{p}{\rho}.$$

Thus, the Bernoulli equation [Eq. (6.28.9)] becomes

$$\frac{\gamma}{\gamma-1} \frac{p}{\rho} + \frac{v^2}{2} = \text{constant}.$$

We note that this is the same result as that obtained in Example 6.26.2 [Eq. (6.26.5)] by the use of the energy equation. In other words, under the conditions stated (inviscid, non-heat-conducting, initial homogeneous state), the Bernoulli equation and the energy equation are the same.

Example 6.28.2

Let p_0 denote the pressure at zero speed (called the *stagnation pressure*). Show that for isentropic steady flow ($\rho/\rho^\gamma = \text{constant}$) of an ideal gas,

$$p_0 = p \left[1 + \frac{1}{2}(\gamma-1) \left(\frac{v}{c} \right)^2 \right]^{\frac{\gamma}{\gamma-1}}, \quad (6.28.11)$$

where c is the local speed of sound.

Solution

Since (see previous example)

$$\frac{\gamma}{\gamma-1} \frac{p}{\rho} + \frac{v^2}{2} = \text{constant} = \frac{\gamma}{\gamma-1} \frac{p_0}{\rho_0}, \quad \text{and} \quad c^2 = \frac{\gamma p}{\rho} \quad [\text{see Eq. (6.27.14)},$$

therefore,

$$\frac{v^2}{2c^2} = \frac{\gamma}{\gamma-1} \left(\frac{p_0}{\rho_0} - \frac{p}{\rho} \right) \frac{\rho}{\gamma p} = \frac{1}{\gamma-1} \left[\left(\frac{p_0}{p} \right) \left(\frac{\rho}{\rho_0} \right) - 1 \right] = \frac{1}{\gamma-1} \left[\left(\frac{p_0}{p} \right) \left(\frac{p_0}{p} \right)^{-\frac{1}{\gamma}} - 1 \right] = \frac{1}{\gamma-1} \left[\left(\frac{p_0}{p} \right)^{\frac{\gamma-1}{\gamma}} - 1 \right].$$

Thus,

$$\left(\frac{p_0}{p} \right) = \left[1 + \frac{1}{2}(\gamma-1) \frac{v^2}{c^2} \right]^{\frac{\gamma}{\gamma-1}},$$

which is Eq. (6.28.11).

Example 6.28.3

Obtain the following relations:

$$p_0 = p + \frac{\rho v^2}{2} \quad (6.28.12)$$

for a small *Mach number*, defined as

$$M = \frac{v}{c}. \quad (6.28.13)$$

Solution

The binomial expansion of Eq. (6.28.11) gives, for small v/c ,

$$\frac{p_0}{p} = \left[1 + \frac{1}{2}(\gamma-1) \left(\frac{v}{c} \right)^2 \right]^{\frac{\gamma}{\gamma-1}} = 1 + \frac{1}{2}\gamma \left(\frac{v}{c} \right)^2 + \dots = 1 + \frac{1}{2} \left(\frac{\gamma}{c^2} \right) v^2 + \dots$$

Now

$$\frac{\gamma}{c^2} = \frac{\gamma}{(\gamma p / \rho)} = \frac{\rho}{p}.$$

Therefore, for a small Mach number M , we have

$$p_0 = p + \frac{\rho v^2}{2},$$

which is Eq. (6.28.12).

We note that this equation is the same as that for an incompressible fluid. In other words, for steady isentropic flow, the fluid may be considered incompressible if the Mach number is small.

6.29 ONE-DIMENSIONAL FLOW OF A COMPRESSIBLE FLUID

In this section, we discuss some internal flow problems of a compressible fluid. The fluid will be assumed to be an ideal gas. The flow will be assumed to be one-dimensional in the sense that the pressure, temperature, density, velocity, and so on are uniform over any cross-section of the channel or duct in which the fluid is flowing. The flow will also be assumed to be steady and adiabatic.

In steady flow, the rate of mass flow is constant for all cross-sections. With A denoting the variable cross-sectional area, ρ the density, and v the velocity, we have

$$\rho Av = \text{constant}. \quad (6.29.1)$$

Taking the total derivative of the preceding equation, we get

$$(Av)d\rho + (\rho v)dA + (\rho A)dv = 0. \quad (6.29.2)$$

That is,

$$\frac{d\rho}{\rho} + \frac{dA}{A} + \frac{dv}{v} = 0. \quad (6.29.3)$$

In the following example, we show that for steady isentropic flow of an ideal gas in one dimension, we have

$$\frac{dA}{A} = \frac{dv}{v} (M^2 - 1), \quad (6.29.4)$$

where M is the Mach number. Eq. (6.29.4) is known as the *Hugoniot equation*.

Example 6.29.1

Derive the Hugoniot equation.

Solution

From Eq. (6.28.9), i.e.,

$$\int \frac{dp}{\rho} + \frac{v^2}{2} = \text{constant}, \quad (6.29.5)$$

we obtain

$$v dv + \frac{dp}{\rho} = 0 = v dv + \frac{1}{\rho} \frac{dp}{d\rho} d\rho. \quad (i)$$

The speed of sound $c^2 = \frac{dp}{d\rho}$, therefore,

$$\frac{d\rho}{\rho} = -\frac{v dv}{c^2}. \quad (ii)$$

Using Eq. (6.29.3) and the preceding equation, we have

$$\frac{dA}{A} = \frac{v dv}{c^2} - \frac{dv}{v} = \frac{dv}{v} (M^2 - 1), \quad (iii)$$

which is Eq. (6.29.4).

From the Hugoniot equation, we see that for subsonic flows ($M < 1$), an increase in area produces a decrease in velocity, just as in the case of an incompressible fluid. On the other hand, for supersonic flow ($M > 1$), an increase in area produces an increase in velocity. Furthermore, the critical velocity ($M = 1$) can only be obtained at the smallest cross-sectional area where $dA = 0$.

6.30 STEADY FLOW OF A COMPRESSIBLE FLUID EXITING A LARGE TANK THROUGH A NOZZLE

We consider the adiabatic flow of an ideal gas exiting a large tank (inside which the pressure p_1 and the density ρ_1 remain essentially unchanged) through two types of exit nozzles: (a) a convergent nozzle and (b) a convergent-divergent nozzle. The surrounding pressure of the exit jet is $p_R \leq p_1$.

A. The Case of a Divergent Nozzle

Application of the energy equation [Eq. (6.28.10)], using the conditions inside the tank and at the section 2 of the exit jet, gives

$$\frac{v_2^2}{2} + \frac{\gamma}{\gamma - 1} \frac{p_2}{\rho_2} = 0 + \frac{\gamma}{\gamma - 1} \frac{p_1}{\rho_1}, \quad (6.30.1)$$

where p_2 , ρ_2 and v_2 are pressure, density, and velocity at section 2 of the exit jet. Thus

$$v_2^2 = \frac{2\gamma}{\gamma - 1} \frac{p_1}{\rho_1} \left(1 - \frac{\rho_1 p_2}{\rho_2 p_1} \right). \quad (6.30.2)$$

For adiabatic flow,

$$\left(\frac{p_2}{p_1} \right)^{1/\gamma} = \frac{\rho_2}{\rho_1}. \quad (6.30.3)$$

Using the preceding equation, we can eliminate ρ_2 from Eq. (6.30.2) and obtain

$$v_2^2 = \frac{2\gamma}{\gamma - 1} \frac{p_1}{\rho_1} \left(1 - \left(\frac{p_2}{p_1} \right)^{\frac{\gamma-1}{\gamma}} \right). \quad (6.30.4)$$

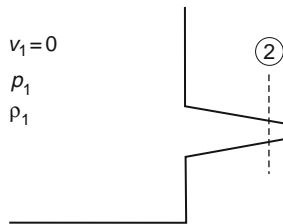

FIGURE 6.30-1

The rate of mass flow dm/dt exiting the tank is (with A_2 denoting the cross-sectional area at section 2)

$$\frac{dm}{dt} = A_2 \rho_2 v_2 = A_2 \frac{\rho_2}{\rho_1} \rho_1 v_2 = A_2 \left(\frac{p_2}{p_1} \right)^{1/\gamma} \rho_1 v_2. \quad (6.30.5)$$

Using Eq. (6.30.2) in the preceding equation, we get $v_2^2 = \frac{2\gamma}{\gamma-1} \frac{p_1}{\rho_1} \left(1 - \frac{\rho_1 p_2}{\rho_2 p_1} \right)$

$$\frac{dm}{dt} = A_2 \left[\frac{2\gamma}{\gamma-1} p_1 \rho_1 \left\{ \left(\frac{p_2}{p_1} \right)^{2/\gamma} - \left(\frac{p_2}{p_1} \right)^{(\gamma+1)/\gamma} \right\} \right]^{1/2}. \quad (6.30.6)$$

For given p_1 , ρ_1 and A_2 , dm/dt depends on p_2/p_1 . We see from the preceding equation that $dm/dt = 0$ when $p_2/p_1 = 1$ as expected. It also shows $dm/dt = 0$ when $p_2 = 0$. This last root is not acceptable; we show below that for a convergent nozzle, the pressure p_2 , at the exit section 2 inside the jet, can never be less than a critical value p_c .

Let us calculate the maximum value of dm/dt . Taking the derivative of (dm/dt) with respect to p_2/p_1 and setting it to zero, we get (see Prob. 6.58)

$$\left(\frac{p_2}{p_1} \right) = \left(\frac{2}{\gamma+1} \right)^{\frac{\gamma}{\gamma-1}}. \quad (6.30.7)$$

The preceding equation gives the *critical value* p_c for a given value of p_1 . At this value of p_2/p_1 , it can be obtained

$$v_2^2 = \gamma \left(\frac{p_2}{\rho_2} \right) = \text{speed of sound at section 2 of the exit jet}. \quad (6.30.8)$$

That is, for a given p_1 , when the pressure p_2 at the exit section (section 2 in the figure) reaches the critical value given by Eq. (6.30.7), the speed at that section reaches the speed of sound. Now, the pressure at section 2 can never be less than the critical value because otherwise the flow will become supersonic at section 2, which is impossible in view of the conclusion reached in the last section, that to have $M = 1$, dA must be zero and to have $M > 1$, dA must be increasing (divergent nozzle). Thus, for the case of a convergent nozzle, p_2 can never be less than p_c , the pressure surrounding the exit jet. When $p_R > p_c$, $p_2 = p_R$, and when $p_R < p_c$, $p_2 = p_c$. The rate of mass flow is,

$$\text{for } p_R \geq p_c, \quad \frac{dm}{dt} = A_2 \left[\frac{2\gamma}{\gamma-1} (p_1 \rho_1) \right]^{1/2} \left[\left(\frac{p_R}{p_1} \right)^{2/\gamma} - \left(\frac{p_R}{p_1} \right)^{(\gamma+1)/\gamma} \right]^{1/2}, \quad (6.30.9)$$

and for $p_R \leq p_c$,

$$\frac{dm}{dt} = A_2 \left[\frac{2\gamma}{\gamma-1} (p_1 \rho_1) \right]^{1/2} \left[\left(\frac{2}{\gamma+1} \right)^{2/(\gamma-1)} - \left(\frac{2}{\gamma+1} \right)^{(\gamma+1)/(\gamma-1)} \right]^{1/2} = \text{constant}. \quad (6.30.10)$$

B. The Case of a Convergent-Divergent Nozzle

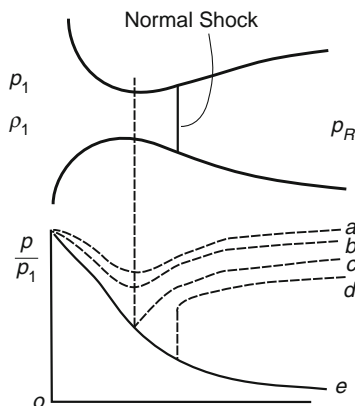

FIGURE 6.30-2

In this case, we take section 2 to be at the throat where $dA = 0$. From the results in (a), we know that the flow in the convergent part of the nozzle is always subsonic, regardless of the receiver pressure $p_R (< p_1)$. The flow in the diverging passage is subsonic for a certain range of p_R/p_1 (curves *a* and *b* in Figure 6.30-2). There is a value of p_R at which the flow at the throat is sonic; the flow corresponding to this case is known as *choked flow* (curve *c*). Further reductions of p_R cannot affect the condition at the throat and produce no change in flow rate. There is one receiver pressure, p_R , for which the flow can expand isentropically to p_R (the solid curve *e*). If the receiver pressure is between *c* and *e*, such as *d*, the flow following the throat for a short distance will be supersonic. This is then followed by a discontinuity in pressure (compression shock), and flow becomes subsonic for the remaining distance to the exit. If the receiver pressure is below that indicated by *e* in the figure, a series of expansion waves and oblique shock waves occur outside the nozzle.

6.31 STEADY LAMINAR FLOW OF A NEWTONIAN FLUID IN A THIN ELASTIC TUBE: AN APPLICATION TO PRESSURE-FLOW RELATION IN A PULMONARY BLOOD VESSEL

In Section 6.13, we obtain the relation between the volume flow rate Q and the pressure gradient for the Hagen Poiseuille flow as

$$Q = -\left(\frac{dp}{dz}\right) \frac{\pi d^4}{128\mu} = -\left(\frac{dp}{dz}\right) \frac{\pi r^4}{8\mu}. \quad (6.31.1)$$

Thus,

$$\left(\frac{dp}{dz}\right) = -\frac{8\mu}{\pi r^4} Q \quad \text{or} \quad r^4 dp = -\frac{8\mu}{\pi} Q dz. \quad (6.31.2)$$

This formula is for flow of a viscous fluid in a *rigid* cylindrical tube, where the radius of the tube is independent of the pressure, which decreases in the flow direction. For an elastic tube, however, the radius depends on the pressure so that upstream radii will be larger than downstream radii. That is, it will be a function of z .

Let r_o be the uniform radius of a thin elastic tube at zero fluid pressure. The average local circumferential strain of the thin tube is given by

$$E_{\theta\theta} = \frac{r - r_o}{r_o}, \quad (6.31.3)$$

and for a thin tube, the local hoop stress $T_{\theta\theta}$ can be calculated from the formula

$$T_{\theta\theta} = \frac{pr}{t}, \quad (6.31.4)$$

where t is the wall thickness, which is assumed to be very small (that is, $t/r \ll 1$). We note that when $r = r_o$, $E_{\theta\theta} = 0$ and $p = 0$. Now, by Hooke's law,

$$E_{\theta\theta} = \frac{T_{\theta\theta}}{E_Y} = \frac{pr}{tE_Y}, \quad (6.31.5)$$

where E_Y is the Young's modulus. Thus,

$$\frac{r - r_o}{r_o} = \frac{pr}{tE_Y}, \quad (6.31.6)$$

from which we have

$$r = r_o \left(1 - \frac{r_o p}{tE_Y} \right)^{-1}. \quad (6.31.7)$$

Substituting Eq. (6.31.7) in Eq. (6.31.2), we obtain

$$\int_{p(0)}^{p(L)} \left(1 - \frac{r_o p}{tE_Y} \right)^{-4} dp = - \int_0^L \frac{8\mu}{\pi r_o^4} Q dz. \quad (6.31.8)$$

Thus

$$Q = \frac{r_o^3 \pi t E_Y}{24 \mu L} \left[\left(1 - \frac{r_o p(0)}{tE_Y} \right)^{-3} - \left(1 - \frac{r_o p(L)}{tE_Y} \right)^{-3} \right]. \quad (6.31.9)$$

Unlike the case of a rigid uniform tube where Q is directly proportional to $[p(0) - p(L)]$, here it depends on $p(0)$ and $p(L)$ in a nonlinear manner given in Eq. (6.31.9).

Example 6.31.1

Obtain the pressure-flow relation for a deformable thin tube where the pressure-radius relationship is known to be given by

$$r = r_o + \alpha \frac{p}{2}. \quad (6.31.10)$$

This relation is known to be a good representation of the pulmonary blood vessel (see Fung, *Biodynamics: Circulation*, Springer-Verlag, 1984, and the references therein). In the preceding equation, r_o is the radius when the transmural pressure (pressure across the wall) is zero and α is a compliance constant.

Solution

Using Eq. (6.30.10), we have

$$\frac{dp}{dz} = \frac{dp}{dr} \frac{dr}{dz} = \frac{2}{\alpha} \frac{dr}{dz}.$$

Thus, from Eq. (6.31.2), we have

$$\frac{2}{\alpha} \frac{dr}{dz} = - \frac{8\mu}{\pi r^4} Q.$$

Integrating the preceding equation, we have

$$\int_{r(0)}^{r(L)} r^4 dr = - \int_0^L \frac{4\alpha\mu Q}{\pi} dz,$$

from which we obtain

$$r^5(0) - r^5(L) = \frac{20\alpha\mu Q}{\pi} L. \quad (6.31.11)$$

We see that the volume flow rate varies with the difference of the fifth power of the tube radius at the entry section ($z = 0$) minus that at the exit section ($z = L$).

Using Eq. (6.30.10), i.e., $r = r_0 + \alpha \frac{\rho}{2}$, we get

$$\left[r_0 + \alpha \frac{\rho(0)}{2} \right]^5 - \left[r_0 + \alpha \frac{\rho(L)}{2} \right]^5 = \frac{20\alpha\mu Q}{\pi} L. \quad (6.31.12)$$

This is the pressure-flow relationship.

PROBLEMS FOR CHAPTER 6

- 6.1** In Figure P6.1, the gate AB is rectangular with width $b = 60$ cm and length $L = 4$ m. The gate is hinged at the upper edge A . Neglecting the weight of the gate, find the reactional force at B . Take the specific weight of water to be 9800 N/m^3 and neglect friction.

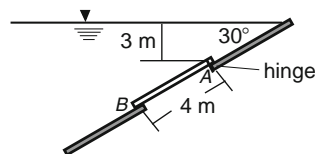

FIGURE P6.1

- 6.2** The gate AB in Figure P6.2 is 5 m long and 3 m wide. Neglecting the weight of the gate, compute the water level h for which the gate will start to fall. Take the specific weight of water to be 9800 N/m^3 .

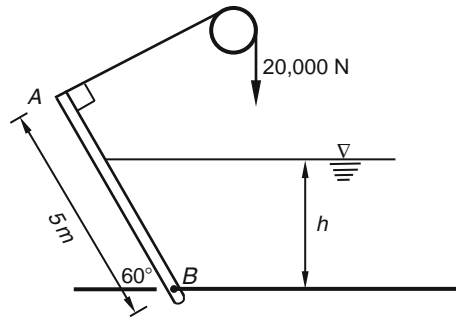

FIGURE P6.2

6.3 The liquid in the U-tube shown in Figure P6.3 is in equilibrium. Find h_2 as a function of $\rho_1, \rho_2, \rho_3, h_1$ and h_3 . The liquids are immiscible.

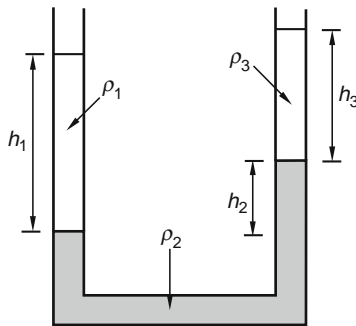

FIGURE P6.3

6.4 In Figure P6.4, the weight W_R is supported by the weight W_L via the liquid in the container. The area under W_R is twice that under W_L . Find W_R in terms of W_L, ρ_1, ρ_2, A_L , and h ($\rho_2 < \rho_1$ and assume no mixing).

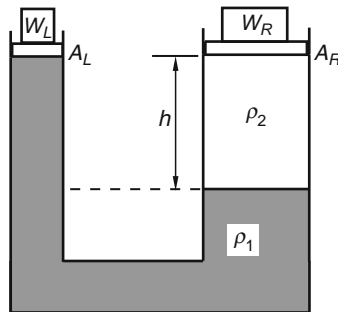

FIGURE P6.4

- 6.5 Referring to Figure P6.5, the radius and length of the cylinder are r and L , respectively. The specific weight of the liquid is γ . (a) Find the buoyancy force on the cylinder, and (b) find the resultant force on the cylindrical surface due to the water pressure. The centroid of a semicircular area is $4r/3\pi$ from the diameter.

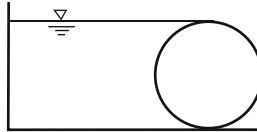

FIGURE P6.5

- 6.6 A glass of water moves vertically upward with a constant acceleration a . Find the pressure at a point whose depth from the surface of the water is h . Take the atmospheric pressure to be p_a .
- 6.7 A glass of water shown in Figure P6.6 moves with a constant acceleration a in the direction shown. (a) Show that the free surface is a plane and find its angle of inclination, and (b) find the pressure at the point A. Take the atmospheric pressure to be p_a .

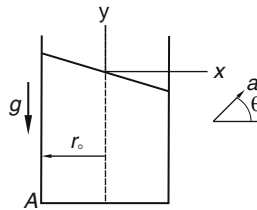

FIGURE P6.6

- 6.8 The slender U-tube shown in Figure P6.7 moves horizontally to the right with an acceleration a . Determine the relation among a , ℓ and h .

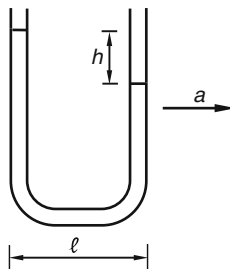

FIGURE P6.7

- 6.9 A liquid in a container rotates with a constant angular velocity ω about a vertical axis. Show that the free surface is a paraboloid given by $z = (r^2\omega^2)/2g$, where the origin is on the axis of rotation and z is measured upward from the lowest point of the free surface.
- 6.10 The slender U-tube rotates with an angular velocity ω about the vertical axis shown in Figure P6.8. Find the relation among $\delta h(\equiv h_1 - h_2)$, ω , r_1 and r_2 .

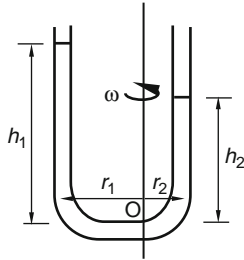

FIGURE P6.8

- 6.11 For minor altitude differences, the atmosphere can be assumed to have constant temperature. Find the pressure and density distribution for this case. The pressure p , density ρ , and absolute temperature Θ are related by the ideal gas law $p = \rho R \Theta$.
- 6.12 In astrophysical applications, an atmosphere having the relation between the density ρ and the pressure p given by $p/p_0 = (\rho/\rho_0)^n$, where p_0 and ρ_0 are some reference pressure and density, is known as a *polytropic atmosphere*. Find the distribution of pressure and density in a polytropic atmosphere.
- 6.13 Given the following velocity field for a Newtonian liquid with viscosity $\mu = 0.982 \text{ mPa}\cdot\text{s}$ ($2.05 \times 10^{-5} \text{ lb} \times \text{s}/\text{ft}^2$): $v_1 = -c(x_1 + x_2)$, $v_2 = c(x_2 - x_1)$, $v_3 = 0$, $c = 1 \text{ s}^{-1}$. For a plane whose normal is in the \mathbf{e}_1 direction, (a) find the excess of the total normal compressive stress over the pressure p , and (b) find the magnitude of the shearing stress.
- 6.14 For a steady parallel flow of an incompressible linearly viscous fluid, if we take the flow direction to be \mathbf{e}_3 , (a) show that the velocity field is of the form $v_1 = 0$, $v_2 = 0$, and $v_3 = v(x_1, x_2)$. (b) If $v(x_1, x_2) = kx_2$, find the normal and shear stresses on the plane whose normal is in the direction of $\mathbf{e}_2 + \mathbf{e}_3$ in terms of viscosity μ and pressure p , and (c) on what planes are the total normal stresses given by p ?
- 6.15 Given the following velocity field for a Newtonian incompressible fluid with a viscosity $\mu = 0.96 \text{ mPa}\cdot\text{s}$: $v_1 = k(x_1^2 - x_2^2)$, $v_2 = -2kx_1x_2$, $v_3 = 0$, $k = 1 \text{ s}^{-1}\text{m}^{-1}$. At the point $(1, 2, 1)\text{m}$ and on the plane whose normal is in the direction of \mathbf{e}_1 , (a) find the excess of the total normal compressive stress over the pressure p , and (b) find the magnitude of the shearing stress.
- 6.16 Do Prob. 6.15 except that the plane has a normal in the direction $3\mathbf{e}_1 + 4\mathbf{e}_2$.
- 6.17 Using the results of Section 2.34, Chapter 2, and the constitutive equations for the Newtonian viscous fluid, verify the Navier-Stokes equation in the r -direction in cylindrical coordinates, Eq. (6.8.1).
- 6.18 Using the results of Section 2.35, Chapter 2, and the constitutive equations for the Newtonian viscous fluid, verify Navier-Stokes equation in the r -direction in spherical coordinates, Eq. (6.8.5).

- 6.19** Show that for a steady flow, the streamline containing a point P coincides with the pathline for a particle that passes through the point P at some time t .
- 6.20** Given the two-dimensional velocity field $v_1 = kx_1x_2/(1 + kx_2t)$, $v_2 = 0$. (a) Find the streamline at time t , which passes through the spatial point (α_1, α_2) , and (b) find the pathline equation $\mathbf{x} = \mathbf{x}(t)$ for a particle that is at (X_1, X_2) at time t_0 .
- 6.21** Given the two-dimensional flow $v_1 = kx_2$, $v_2 = 0$. (a) Obtain the streamline passing through the point (α_1, α_2) . (b) Obtain the pathline for the particle that is at (X_1, X_2) at $t = 0$, including the time history of the particle along the pathline.
- 6.22** Do Prob. 6.21 for the following velocity field: $v_1 = \omega x_2$, $v_2 = -\omega x_1$.
- 6.23** Given the following velocity field in polar coordinates (r, θ) :
- $$v_r = Q/(2\pi r), \quad v_\theta = 0.$$
- (a) Obtain the streamline passing through the point (r_0, θ_0) , and (b) obtain the pathline for the particle that is at (R, Θ) at $t = 0$, including the time history of the particle along the pathline.
- 6.24** Do Prob. 6.23 for the following velocity field in polar coordinates (r, θ) : $v_r = 0$, $v_\theta = C/r$.
- 6.25** From the Navier-Stokes equations, obtain Eq. (6.11.2) for the velocity distribution of the plane Couette flow.
- 6.26** For the plane Couette flow, if in addition to the movement of the upper plate there is also an applied negative pressure gradient $\partial p/\partial x_1$, obtain the velocity distribution. Also obtain the volume flow rate per unit width.
- 6.27** Obtain the steady unidirectional flow of an incompressible viscous fluid layer of uniform depth d flowing down an inclined plane, which makes an angle θ with the horizontal.
- 6.28** A layer of water ($\rho g = 62.4 \text{ lb/ft}^3$) flows down an inclined plane ($\theta = 30^\circ$) with a uniform thickness of 0.1 ft. Assuming the flow to be laminar, what is the pressure at any point on the inclined plane? Take the atmospheric pressure to be zero.
- 6.29** Two layers of liquids with viscosities μ_1 and μ_2 , densities ρ_1 and ρ_2 , respectively, and with equal depths b flow steadily between two fixed horizontal parallel plates. Find the velocity distribution for this steady unidirectional flow.
- 6.30** For the Couette flow of Section 6.15, (a) obtain the shear stress at any point inside the fluid, (b) obtain the shear stress on the outer and inner cylinder, and (c) obtain the torque that must be applied to the cylinders to maintain the flow.
- 6.31** Verify the equation $\beta^2 = \rho\omega/2\mu$ for the oscillating problem of Section 6.16.
- 6.32** Consider the flow of an incompressible viscous fluid through the annular space between two concentric horizontal cylinders. The radii are a and b . (a) Find the flow field if there is no variation of pressure in the axial direction and if the inner and the outer cylinders have axial velocities v_a and v_b , respectively, and (b) find the flow field if there is a pressure gradient in the axial direction and both cylinders are fixed. Take body forces to be zero.
- 6.33** Show that for the velocity field: $v_x = v(y, z)$, $v_y = v_z = 0$, the Navier-Stokes equations, with $\mathbf{B} = 0$, reduce to $\frac{\partial^2 v}{\partial y^2} + \frac{\partial^2 v}{\partial z^2} = \frac{1}{\mu} \frac{dp}{dx} = \beta = \text{constant}$.

6.34 Given the velocity field in the form $v_x = v = A(y^2/a^2 + z^2/b^2) + B$, $v_y = v_z = 0$. Find A and B for the steady laminar flow of a Newtonian fluid in a pipe having an elliptical cross-section given by $y^2/a^2 + z^2/b^2 = 1$. Assume no body forces, and use the governing equation obtained in the previous problem.

6.35 Given the velocity field in the form of

$$v_x = A \left(z + \frac{b}{2\sqrt{3}} \right) \left(z + \sqrt{3}y - \frac{b}{\sqrt{3}} \right) \left(z - \sqrt{3}y - \frac{b}{\sqrt{3}} \right) + B, \quad v_y = v_z = 0.$$

Find A and B for the steady laminar flow of a Newtonian fluid in a pipe having an equilateral triangular cross-section defined by the planes

$$z + \frac{b}{2\sqrt{3}} = 0, \quad z + \sqrt{3}y - \frac{b}{\sqrt{3}} = 0, \quad z - \sqrt{3}y - \frac{b}{\sqrt{3}} = 0.$$

Assume no body forces, and use the governing equation obtained in Prob. 6.33.

6.36 For the steady-state, time-dependent parallel flow of water (density $\rho = 10^3 \text{ kg/m}^3$, viscosity $\mu = 10^{-3} \text{ Ns/m}^2$) near an oscillating plate, calculate the wave length for $\omega = 2 \text{ cps}$.

6.37 The space between two concentric spherical shells is filled with an incompressible Newtonian fluid. The inner shell (radius r_i) is fixed; the outer shell (radius r_o) rotates with an angular velocity Ω about a diameter. Find the velocity distribution. Assume the flow to be laminar without secondary flow.

6.38 Consider the following velocity field in cylindrical coordinates for an incompressible fluid:

$$v_r = v(r), \quad v_\theta = 0, \quad v_z = 0.$$

(a) Show that $v_r = A/r$, where A is a constant, so that the equation of conservation of mass is satisfied.
 (b) If the rate of mass flow through the circular cylindrical surface of radius r and unit length (in z -direction) is Q_m , determine the constant A in terms of Q_m .

6.39 Given the following velocity field in cylindrical coordinates for an incompressible fluid: $v_r = v(r, \theta)$, $v_\theta = 0$, $v_z = 0$. Show that (a) $v_r = f(\theta)/r$, where $f(\theta)$ is any function of θ , and (b) in the absence of body forces,

$$\frac{d^2f}{d\theta^2} + 4f + \frac{\rho f^2}{\mu} + k = 0, \quad p = 2\mu \frac{f}{r^2} + \frac{k\mu}{2r^2} + C, \quad k \text{ and } C \text{ are constants.}$$

6.40 Consider the steady two-dimensional channel flow of an incompressible Newtonian fluid under the action of an applied negative pressure gradient $\partial p / \partial x_1$, as well as the movement of the top plate with velocity v_o in its own plane (see Prob. 6.26). Determine the temperature distribution for this flow due to viscous dissipation when both plates are maintained at the same fixed temperature θ_o . Assume constant physical properties.

6.41 Determine the temperature distribution in the plane Poiseuille flow where the bottom plate is kept at a constant temperature Θ_1 and the top plate at Θ_2 . Include the heat generated by viscous dissipation.

6.42 Determine the temperature distribution in the steady laminar flow between two coaxial cylinders (Couette flow) if the temperatures at the inner and the outer cylinders are kept at the same fixed temperature Θ_o .

6.43 Show that the dissipation function for a compressible fluid can be written as that given in Eq. (6.17.10).

- 6.44** Given the velocity field of a linearly viscous fluid: $v_1 = kx_1$, $v_2 = -kx_2$, $v_3 = 0$. (a) Show that the velocity field is irrotational. (b) Find the stress tensor. (c) Find the acceleration field. (d) Show that the velocity field satisfies the Navier-Stokes equations by finding the pressure distribution directly from the equations. Neglect body forces. Take $p = p_0$ at the origin. (e) Use the Bernoulli equation to find the pressure distribution. (f) Find the rate of dissipation of mechanical energy into heat. (g) If $x_2 = 0$ is a fixed boundary, what condition is not satisfied by the velocity field?
- 6.45** Do Prob. 6.44 for the following velocity field: $v_1 = k(x_1^2 - x_2^2)$, $v_2 = -2kx_1x_2$, $v_3 = 0$.
- 6.46** Obtain the vorticity vector for the plane Poiseuille flow.
- 6.47** Obtain the vorticity vector for the Hagen-Poiseuille flow.
- 6.48** For a two-dimensional flow of an incompressible fluid, we can express the velocity components in terms of a scalar function ψ (known as the *Lagrange stream function*) by the relations $v_x = \frac{\partial\psi}{\partial y}$, $v_y = -\frac{\partial\psi}{\partial x}$. (a) Show that the equation of conservation of mass is automatically satisfied for any $\psi(x, y)$ that has continuous second partial derivatives. (b) Show that for two-dimensional flow of an incompressible fluid, $\psi = \text{constants}$ are streamlines. (c) If the velocity field is irrotational, then $v_i = -\partial\varphi/\partial x_i$. Show that the curves of constant velocity potential $\varphi = \text{constant}$ and the streamline $\psi = \text{constant}$ are orthogonal to each other. (d) Obtain the only nonzero vorticity component in terms of ψ .
- 6.49** Show that $\psi = V_0 y \left(1 - \frac{a^2}{x^2 + y^2} \right)$ represents a two-dimensional irrotational flow of an inviscid fluid.
- 6.50** Referring to Figure P6.9, compute the maximum possible flow of water. Take the atmospheric pressure to be 93.1 kPa , the specific weight of water 9810 N/m^3 , and the vapor pressure 17.2 kPa . Assume the fluid to be inviscid. Find the length ℓ for this rate of discharge.

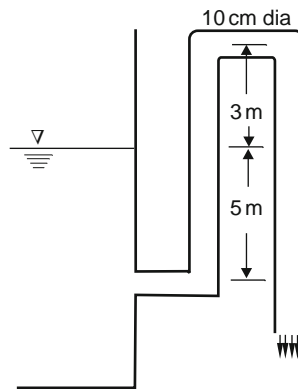

FIGURE P6.9

- 6.51** Water flows upward through a vertical pipeline that tapers from cross-sectional area A_1 to area A_2 in a distance of h . If the pressure at the beginning and end of the constriction are p_1 and p_2 , respectively, determine the flow rate Q in terms of ρ , A_1 , A_2 , p_1 , p_2 and h . Assume the fluid to be inviscid.

- 6.52 Verify that the equation of conservation of mass is automatically satisfied if the velocity components in cylindrical coordinates are given by

$$v_r = -\frac{1}{\rho r} \frac{\partial \psi}{\partial z}, \quad v_z = \frac{1}{\rho r} \frac{\partial \psi}{\partial r}, \quad v_\theta = 0,$$

where the density ρ is a constant and ψ is any function of r and z having continuous second partial derivatives.

- 6.53 From the constitutive equation for a compressible fluid, derive the equation

$$\rho \frac{Dv_i}{Dt} = \rho B_i - \frac{\partial p}{\partial x_i} + \frac{\mu}{3} \frac{\partial}{\partial x_i} \left(\frac{\partial v_j}{\partial x_j} \right) + \mu \frac{\partial^2 v_i}{\partial x_j \partial x_j} + k \frac{\partial}{\partial x_i} \left(\frac{\partial v_j}{\partial x_j} \right).$$

- 6.54 Show that for a one-dimensional, steady, adiabatic flow of an ideal gas, the ratio of temperature Θ_1/Θ_2 at sections 1 and 2 is given by

$$\frac{\Theta_1}{\Theta_2} = \frac{1 + \frac{1}{2}(\gamma - 1)M_1^2}{1 + \frac{1}{2}(\gamma - 1)M_2^2},$$

where γ is the ratio of specific heat, and M_1 and M_2 are local Mach numbers at section 1 and section 2 respectively.

- 6.55 Show that for a compressible fluid in isothermal flow with no external work,

$$\frac{dM^2}{M^2} = 2 \frac{dv}{v},$$

where M is the Mach number. (Assume perfect gas.)

- 6.56 Show that for a perfect gas flowing through a duct of constant cross-sectional area at constant temperature, $\frac{dp}{p} = -\frac{1}{2} \frac{dM^2}{M^2}$. (Use the results of the last problem.)

- 6.57 For the flow of a compressible inviscid fluid around a thin body in a uniform stream of speed V_m in the x_1 direction, we let the velocity potential be $\varphi = -V_o(x_1 + \varphi_1)$, where φ_1 is assumed to be very small. Show that for steady flow, the equation governing φ_1 is, with $M_o = V_o/c_o$,
- $$(1 - M_o^2) \frac{\partial^2 \varphi_1}{\partial x_1^2} + \frac{\partial^2 \varphi_1}{\partial x_2^2} + \frac{\partial^2 \varphi_1}{\partial x_3^2} = 0.$$

- 6.58 For a one-dimensional steady flow of a compressible fluid through a convergent channel, obtain the critical pressure and the corresponding velocity. That is, verify Eqs. (6.30.7) and (6.30.8).

The Reynolds Transport Theorem and Applications

In Chapters 3 and 4, the field equations expressing the principles of conservation of mass, linear momentum, moment of momentum, energy, and entropy inequality were derived by the consideration of differential elements in the continuum (Sections 3.15, 4.7, 4.4, 4.15 and 4.16) and by the consideration of an arbitrary fixed part of the continuum (Section 4.18). In the form of differential equations, the principles are sometimes referred to as *local principles*. In the form of integrals, they are known as *global principles*. Under the assumption of smoothness of functions involved, the two forms are completely equivalent, and in fact the requirement that the global theorem be valid for each and every part of the continuum results in the differential form of the balanced equations, which was demonstrated in Section 4.18; indeed, in that section, the purpose is simply to provide an alternate approach to the formulation of the field equations and to group all the field equations for a continuum into one section for easy reference.

In this chapter, we revisit the derivations of the integral form of the principles with emphasis on the Reynolds transport theorem and its applications to obtain the approximate solutions of engineering problems using the concept of control volumes, moving as well as fixed. A small portion of this chapter is a repeat of Section 4.18, which perhaps is desirable from the point of view of pedagogy. Furthermore, in the derivations used in Section 4.18, it is assumed that the readers are familiar with the divergence theorem; we refer those readers who are not familiar with the theorem to the present chapter, wherein the divergence theorem will be introduced through a generalization of Green's theorem (a two-dimensional divergence theorem), the proof of which is given in detail. A detailed discussion of the distinction between integrals over a control volume and integrals over a material volume is also given before the derivation of the Reynolds transport theorem.

7.1 GREEN'S THEOREM

Let $P(x, y)$, $\partial P/\partial x$ and $\partial P/\partial y$ be continuous functions of x and y in a closed region R bounded by the closed curve C . Let $\mathbf{n} = n_x \mathbf{e}_x + n_y \mathbf{e}_y$ be the unit outward normal of C . Then Green's theorem states that

$$\int_R \frac{\partial P}{\partial x} dA = \int_C P dy = \int_C P n_x ds \quad (7.1.1)$$

and

$$\int_R \frac{\partial P}{\partial y} dA = - \int_C P dx = \int_C P n_y ds, \quad (7.1.2)$$

Let $x = x(s)$ and $y = y(s)$ be the parametric equations for the boundary curve. Then $dy/ds = n_x$ so that

$$\int_R \frac{\partial P}{\partial x} dA = \int_C P n_x ds. \quad (7.1.8)$$

Eq. (7.1.2) can be proven in a similar manner.

Example 7.1.1

For $P(x, y) = xy^2$, evaluate $\int_C P(x, y) n_x ds$ along the closed path $OABC$ (Figure 7.1-2). Also evaluate the area integral

$\int_R \frac{\partial P}{\partial x} dA$. Compare the results.

Solution

We have

$$\int_C P(x, y) n_x ds = \int_{OA} x(0)^2(0) ds + \int_{AB} by^2(1) dy + \int_{BC} xh^2(0) ds + \int_{CO} (0)y^2(-1) ds$$

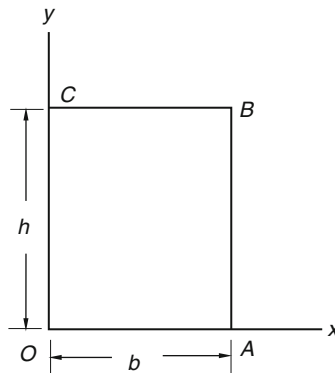

FIGURE 7.1-2

That is,

$$\int_C P(x, y) n_x ds = \int_0^h by^2 dy = \frac{bh^3}{3}.$$

On the other hand,

$$\int_R \frac{\partial P}{\partial x} dA = \int_R y^2 dA = \int_0^h y^2 b dy = \frac{bh^3}{3},$$

and we see

$$\int_C P n_x ds = \int_R \frac{\partial P}{\partial x} dA.$$

7.2 DIVERGENCE THEOREM

Let $\mathbf{v} = v_1(x_1, x_2)\mathbf{e}_1 + v_2(x_1, x_2)\mathbf{e}_2$ be a vector field. Applying Eqs. (7.1.1) and (7.1.2) to v_1 and v_2 and adding, we have

$$\int_C (v_1 n_1 + v_2 n_2) ds = \int_R \left(\frac{\partial v_1}{\partial x_1} + \frac{\partial v_2}{\partial x_2} \right) dA. \quad (7.2.1)$$

In indicial notation, Eq. (7.2.1) reads

$$\int_C v_i n_i ds = \int_R \frac{\partial v_i}{\partial x_i} dA, \quad (7.2.2)$$

and in invariant notation,

$$\int_C \mathbf{v} \cdot \mathbf{n} ds = \int_R (\operatorname{div} \mathbf{v}) dA. \quad (7.2.3)$$

The following generalization not only appears natural but can indeed be proven (we omit the proof):

$$\int_S v_j n_j dS = \int_V \frac{\partial v_j}{\partial x_j} dV. \quad (7.2.4)$$

Or, in invariant notation,

$$\int_S \mathbf{v} \cdot \mathbf{n} dS = \int_V (\operatorname{div} \mathbf{v}) dV, \quad (7.2.5)$$

where S is a surface forming the complete boundary of a bounded closed region R in space and \mathbf{n} is the outward unit normal of S . Equation (7.2.5) is known as the *divergence theorem* (or the *Gauss theorem*). The theorem is valid if the components of \mathbf{v} are continuous and have continuous first partial derivatives in R . It is also valid under less restrictive conditions on the derivatives. In Eq. (7.2.5), if we replace \mathbf{v} with $\alpha\mathbf{v}$, where α is a scalar function, we have

$$\int_S \alpha \mathbf{v} \cdot \mathbf{n} dS = \int_V (\operatorname{div} \alpha \mathbf{v}) dV. \quad (7.2.6)$$

Next, if we replace v_j with T_{ij} in Eq. (7.2.4), where T_{ij} are components of a tensor \mathbf{T} , then we have

$$\int_S T_{ij} n_j dS = \int_V \frac{\partial T_{ij}}{\partial x_j} dV. \quad (7.2.7)$$

Or, in invariant notation,

$$\int_S \mathbf{T} \mathbf{n} dS = \int_V (\operatorname{div} \mathbf{T}) dV. \quad (7.2.8)$$

Equation (7.2.8) is the divergence theorem for a tensor field. It is obvious that for tensor fields of higher order, Eq. (7.2.8) is also valid, provided the Cartesian components of $\operatorname{div} \mathbf{T}$ are defined to be $\partial T_{ijkl\dots s} / \partial x_s$. For example,

$$\int_S T_{ijk} n_k dS = \int_V \frac{\partial T_{ijk}}{\partial x_k} dV. \quad (7.2.9)$$

Example 7.2.1

Let \mathbf{T} be a stress tensor field and let S be a closed surface. Show that the resultant force \mathbf{f} of the distributive forces on S is given by

$$\mathbf{f} = \int_V (\operatorname{div} \mathbf{T}) dV. \quad (7.2.10)$$

Solution

We have

$$\mathbf{f} = \int_S \mathbf{t} dS, \quad (7.2.11)$$

where \mathbf{t} is the stress vector. Now $\mathbf{t} = \mathbf{T}\mathbf{n}$; therefore, from the divergence theorem, we have

$$\mathbf{f} = \int_S \mathbf{t} dS = \int_S \mathbf{T}\mathbf{n} dS = \int_V \operatorname{div} \mathbf{T} dV$$

or, in indicial notation,

$$f_i = \int_V \frac{\partial T_{ij}}{\partial x_j} dV. \quad (7.2.12)$$

Example 7.2.2

Referring to Example 7.2.1, also show that the resultant moment \mathbf{m} about a fixed point O of the distributive forces on S is given by

$$\mathbf{m} = \int_V [\mathbf{x} \times (\operatorname{div} \mathbf{T}) + 2\mathbf{t}^A] dV, \quad (7.2.13)$$

where \mathbf{x} is the position vector of the particle with volume dV , relative to the fixed point O , and \mathbf{t}^A is the axial (or dual) vector of the antisymmetric part of \mathbf{T} (see Section 2.21).

Solution

We have

$$\mathbf{m} = \int_V \mathbf{x} \times \mathbf{t} dS. \quad (7.2.14)$$

Let m_i be the component of \mathbf{m} ; then

$$m_i = \int_S \varepsilon_{ijk} x_j t_k dS = \int_S \varepsilon_{ijk} x_j T_{kp} n_p dS. \quad (7.2.15)$$

Using the divergence theorem, Eq. (7.2.4), we have

$$m_i = \int_V \frac{\partial}{\partial x_p} (\varepsilon_{ijk} x_j T_{kp}) dV. \quad (7.2.16)$$

Now

$$\begin{aligned} \frac{\partial}{\partial x_p} (\varepsilon_{ijk} x_j T_{kp}) &= \varepsilon_{ijk} \left(\frac{\partial x_j}{\partial x_p} T_{kp} + x_j \frac{\partial T_{kp}}{\partial x_p} \right) = \varepsilon_{ijk} \left(\delta_{jp} T_{kp} + x_j \frac{\partial T_{kp}}{\partial x_p} \right) \\ &= \varepsilon_{ijk} \left(T_{kj} + x_j \frac{\partial T_{kp}}{\partial x_p} \right) = -\varepsilon_{ikj} T_{kj} + \varepsilon_{ijk} x_j \frac{\partial T_{kp}}{\partial x_p}. \end{aligned}$$

Noting that $-\varepsilon_{ikj} T_{kj}$ are the components of $2\mathbf{t}^A$ (i.e., twice the dual vector of the antisymmetric part of \mathbf{T}) [see Eq. (2.21.4)], and $\varepsilon_{ijk} x_j \frac{\partial T_{kp}}{\partial x_p}$ are components of $(\mathbf{x} \times \text{div } \mathbf{T})$, we have

$$\mathbf{m} = \int_S \mathbf{x} \times \mathbf{t} dS = \int_V [\mathbf{x} \times (\text{div } \mathbf{T}) + 2\mathbf{t}^A] dV.$$

Example 7.2.3

Referring to Example 7.2.1, show that the total power P (rate of work done) by the stress vector on S is given by

$$P = \int_S \mathbf{t} \cdot \mathbf{v} dS = \int_V [(\text{div } \mathbf{T}) \cdot \mathbf{v} + \text{tr}(\mathbf{T}^T \nabla \mathbf{v})] dV, \quad (7.2.17)$$

where \mathbf{v} is the velocity field.

Solution

The power is given by

$$P = \int_S \mathbf{t} \cdot \mathbf{v} dS = \int_S \mathbf{T} \mathbf{n} \cdot \mathbf{v} dS. \quad (7.2.18)$$

Now $\mathbf{T} \mathbf{n} \cdot \mathbf{v} = \mathbf{n} \cdot \mathbf{T}^T \mathbf{v}$ (definition of the transpose of a tensor), and using the divergence theorem,

$$P = \int_S \mathbf{n} \cdot (\mathbf{T}^T \mathbf{v}) dS = \int_V \text{div}(\mathbf{T}^T \mathbf{v}) dV.$$

Now

$$\text{div}(\mathbf{T}^T \mathbf{v}) = \frac{\partial T_{ji} v_j}{\partial x_i} = \frac{\partial T_{ji}}{\partial x_i} v_j + T_{ji} \frac{\partial v_j}{\partial x_i} = (\text{div } \mathbf{T}) \cdot \mathbf{v} + \text{tr}(\mathbf{T}^T \nabla \mathbf{v}).$$

Thus,

$$P = \int_S \mathbf{t} \cdot \mathbf{v} dS = \int_V [(\text{div } \mathbf{T}) \cdot \mathbf{v} + \text{tr}(\mathbf{T}^T \nabla \mathbf{v})] dV,$$

which is Eq. (7.2.17).

7.3 INTEGRALS OVER A CONTROL VOLUME AND INTEGRALS OVER A MATERIAL VOLUME

Consider first a one-dimensional problem in which the motion of a continuum, in Cartesian coordinates, is given by

$$x = \hat{x}(X, t), \quad y = Y, \quad z = Z \quad (7.3.1)$$

and the density field is given by

$$\rho = \rho(x, t). \quad (7.3.2)$$

The integral

$$m(t, x^{(1)}, x^{(2)}) = \int_{x^{(1)}}^{x^{(2)}} \rho(x, t) A dx, \quad (7.3.3)$$

with fixed values of $x^{(1)}$ and $x^{(2)}$ is an integral over a fixed *control volume*; it gives the total mass at time t within the spatially fixed cylindrical volume of constant cross-sectional area A and bounded by the end faces $x = x^{(1)}$ and $x = x^{(2)}$.

Let $X^{(1)}, X^{(2)}$ be the material coordinates for the particles, which, at time t , are at $x^{(1)}$ and $x^{(2)}$, respectively, i.e., $x^{(1)} = \hat{x}(X^{(1)}, t)$ and $x^{(2)} = \hat{x}(X^{(2)}, t)$. Then the integral

$$M(t, X^{(1)}, X^{(2)}) = \int_{\hat{x}(X^{(1)}, t)}^{\hat{x}(X^{(2)}, t)} \rho(x, t) A dx, \quad (7.3.4)$$

with its integration limits functions of time (in accordance with the motion of the material particles that at time t are at $x^{(1)}$ and $x^{(2)}$), is an integral over a material volume; it gives the total mass at time t of that part of the material that is instantaneously (at time t) coincidental with that inside the fixed boundary surface considered in Eq. (7.3.3). Obviously, at time t , both integrals, i.e., Eqs. (7.3.3) and (7.3.4), have the same value. At other times, say at $t + dt$, however, they have different values. Indeed,

$$\frac{\partial m}{\partial t} \equiv \left[\frac{\partial}{\partial t} \int_{x^{(1)}}^{x^{(2)}} \rho(x, t) A dx \right]_{x^{(1)}, x^{(2)} - \text{fixed}}, \quad (7.3.5)$$

is different from

$$\frac{\partial M}{\partial t} \equiv \left[\frac{\partial}{\partial t} \int_{\hat{x}(X^{(1)}, t)}^{\hat{x}(X^{(2)}, t)} \rho(x, t) A dx \right]_{X^{(1)}, X^{(2)} - \text{fixed}} \equiv \frac{D}{Dt} \int_{\hat{x}(X^{(1)}, t)}^{\hat{x}(X^{(2)}, t)} \rho(x, t) A dx. \quad (7.3.6)$$

We note that $\partial m / \partial t$ in Eq. (7.3.5) gives the rate at which mass is increasing inside the fixed control volume bounded by the cylindrical lateral surface and the end faces $x = x^{(1)}$ and $x = x^{(2)}$, whereas $\partial M / \partial t$ in Eq. (7.3.6) gives the rate of increase of the mass of that part of the material that at time t is coincidental with that in the fixed control volume. They should obviously be different. In fact, the principle of conservation of mass demands that the mass within a material volume should remain a constant, whereas the mass within the fixed control volume in general changes with time.

The preceding example serves to illustrate the two types of volume integrals that we employ in the following sections. We use V_c to indicate a fixed *control volume* and V_m to indicate a *material volume*. That is, for any tensor \mathbf{T} (including a scalar), the integral

$$\int_{V_c} \mathbf{T}(\mathbf{x}, t) dV$$

is over the fixed control volume V_c , and the rate of change of this integral is denoted by

$$\frac{\partial}{\partial t} \int_{V_c} \mathbf{T}(\mathbf{x}, t) dV,$$

whereas the integral

$$\int_{V_m} \mathbf{T}(\mathbf{x}, t) dV,$$

is over the material volume and the rate of change of this integral is denoted by

$$\frac{D}{Dt} \int_{V_m} \mathbf{T}(\mathbf{x}, t) dV.$$

7.4 THE REYNOLDS TRANSPORT THEOREM

Let $\mathbf{T}(\mathbf{x}, t)$ be a given scalar or tensor function of spatial coordinates (x_1, x_2, x_3) and time t . Examples of $\mathbf{T}(\mathbf{x}, t)$ are density $\rho(\mathbf{x}, t)$, linear momentum $\rho(\mathbf{x}, t)\mathbf{v}(\mathbf{x}, t)$, and angular momentum $\mathbf{r} \times \rho(\mathbf{x}, t)\mathbf{v}(\mathbf{x}, t)$.

Let $\int_{V_m} \mathbf{T}(\mathbf{x}, t) dV$ be an integral of $\mathbf{T}(\mathbf{x}, t)$ over a material volume V_m . As discussed in the last section, the material volume V_m consists of the same material particles at all times and therefore has time-dependent boundary S_m due to the movement of the material.

We wish to evaluate the rate of change of such integrals (e.g., the rate of change of mass, of linear momentum, and so on of a material volume) and to relate them to physical laws (such as the conservation of mass, balance of linear momentum, and the like).

The *Reynolds transport theorem* states that

$$\frac{D}{Dt} \int_{V_m(t)} \mathbf{T}(\mathbf{x}, t) dV = \int_{V_c} \frac{\partial \mathbf{T}(\mathbf{x}, t)}{\partial t} dV + \int_{S_c} \mathbf{T}(\mathbf{v} \cdot \mathbf{n}) dS, \quad (7.4.1)$$

or

$$\frac{D}{Dt} \int_{V_m(t)} \mathbf{T}(\mathbf{x}, t) dV = \int_{V_c} \left(\frac{D\mathbf{T}}{Dt} + \mathbf{T} \operatorname{div} \mathbf{v} \right) dV, \quad (7.4.2)$$

where V_c is the control volume (fixed in space) that instantaneously coincides with the material volume V_m (moving with the continuum), S_c is the boundary surface of V_c , and \mathbf{n} is the outward unit normal vector. We note that the notation D/Dt in front of the integral at the left-hand side of Eqs. (7.4.1) and (7.4.2) emphasizes that the boundary surface of the integral moves with the material and we are calculating the rate of change by following the movements of the material.

The Reynolds theorem can be derived in the following two ways:

(a) We have

$$\frac{D}{Dt} \int_{V_m(t)} \mathbf{T}(\mathbf{x}, t) dV = \int_{V_m=V_c} \left[\frac{D}{Dt} (\mathbf{T} dV) \right] = \int_{V_c} \frac{D\mathbf{T}}{Dt} dV + \int_{V_c} \mathbf{T} \frac{D(dV)}{Dt}. \quad (7.4.3)$$

Since [see Eq. (3.13.14)]

$$\frac{D(dV)}{Dt} = (\operatorname{div} \mathbf{v})dV, \quad (7.4.4)$$

Eq. (7.4.3) becomes Eq. (7.4.2). That is,

$$\frac{D}{Dt} \int_{V_{m(t)}} \mathbf{T}(\mathbf{x}, t) dV = \int_{V_c} \left(\frac{D\mathbf{T}}{Dt} + \mathbf{T} \operatorname{div} \mathbf{v} \right) dV.$$

In Cartesian coordinates, the preceding equation reads,

$$\frac{D}{Dt} \int_{V_{m(t)}} T_{ij}(\mathbf{x}, t) dV = \int_{V_c} \left[\frac{DT_{ij}}{Dt} + T_{ij} \left(\frac{\partial v_k}{\partial x_k} \right) \right] dV = \int_{V_c} \left[\frac{\partial T_{ij}}{\partial t} + \left(\frac{\partial T_{ij} v_k}{\partial x_k} \right) \right] dV. \quad (7.4.5)$$

Now, from the Gauss theorem, Eq. (7.2.9), we have

$$\int_V \frac{\partial (T_{ij} v_k)}{\partial x_k} dV = \int_S T_{ij} v_k n_k dS. \quad (7.4.6)$$

Thus,

$$\frac{D}{Dt} \int_{V_{m(t)}} T_{ij}(\mathbf{x}, t) dV = \int_{V_c} \frac{\partial T_{ij}(\mathbf{x}, t)}{\partial t} dV + \int_{S_c} T_{ij} v_k n_k dS.$$

In invariant notation, we have

$$\frac{D}{Dt} \int_{V_{m(t)}} \mathbf{T} dV = \int_{V_c} \frac{\partial \mathbf{T}}{\partial t} dV + \int_{S_c} \mathbf{T}(\mathbf{v} \cdot \mathbf{n}) dS.$$

This is Eq. (7.4.1).

(b) Alternatively, we can derive Eq. (7.4.2) in the following way. Since [see Eq. (3.28.3)]

$$dV = (\det \mathbf{F}) dV_o, \quad (7.4.7)$$

where \mathbf{F} is the deformation gradient and dV_o is the volume at the reference state,

$$\int_{V_m} \mathbf{T}(\mathbf{x}, t) dV = \int_{V_o} \mathbf{T}(\mathbf{x}, t) (\det \mathbf{F}) dV_o, \quad (7.4.8)$$

thus,

$$\frac{D}{Dt} \int_{V_m} \mathbf{T}(\mathbf{x}, t) dV = \int_{V_o} \left[\frac{D}{Dt} (\mathbf{T} \det \mathbf{F}) \right] dV_o = \int_{V_o} \left[\frac{D\mathbf{T}}{Dt} (\det \mathbf{F}) + \mathbf{T} \frac{D(\det \mathbf{F})}{Dt} \right] dV_o. \quad (7.4.9)$$

Now, from Eqs. (7.4.7) and (7.4.4), we have

$$\frac{D(\det \mathbf{F})}{Dt} = \frac{1}{dV_o} \left(\frac{D}{Dt} dV \right) = \frac{1}{dV_o} (\operatorname{div} \mathbf{v}) dV = (\operatorname{div} \mathbf{v}) (\det \mathbf{F}), \quad (7.4.10)$$

therefore, Eq. (7.4.9) becomes

$$\frac{D}{Dt} \int_{V_m} \mathbf{T}(\mathbf{x}, t) dV = \int_{V_c} \left[\frac{D\mathbf{T}}{Dt} + \mathbf{T}(\text{div } \mathbf{v}) \right] \det \mathbf{F} dV_0 = \int_{V_c} \left[\frac{D\mathbf{T}}{Dt} + \mathbf{T}(\text{div } \mathbf{v}) \right] dV,$$

which is Eq. (7.4.2).

From Eqs. (7.4.1) and (7.4.2), we also have

$$\int_{V_c} \frac{\partial \mathbf{T}(\mathbf{x}, t)}{\partial t} dV + \int_{S_c} \mathbf{T}(\mathbf{v} \cdot \mathbf{n}) dS = \int_{V_c} \left(\frac{D\mathbf{T}}{Dt} + \mathbf{T} \text{div } \mathbf{v} \right) dV. \quad (7.4.11)$$

7.5 THE PRINCIPLE OF CONSERVATION OF MASS

The global principle of conservation of mass states that the total mass of a fixed part of a material should remain constant at all times. That is,

$$\frac{D}{Dt} \int_{V_m} \rho(\mathbf{x}, t) dV = 0. \quad (7.5.1)$$

Using Reynolds transport theorem Eq. (7.4.1), we obtain

$$\int_{V_c} \frac{\partial}{\partial t} \rho(\mathbf{x}, t) dV = - \int_{S_c} \rho(\mathbf{v} \cdot \mathbf{n}) dS, \quad (7.5.2)$$

or

$$\frac{\partial}{\partial t} \int_{V_c} \rho(\mathbf{x}, t) dV = - \int_{S_c} \rho(\mathbf{v} \cdot \mathbf{n}) dS. \quad (7.5.3)$$

This equation states that the time rate at which mass is increasing inside a control volume = the mass influx (i.e., net rate of mass inflow) through the control surface. Using Eq. (7.2.6), we have

$$\int_S \rho(\mathbf{v} \cdot \mathbf{n}) dS = \int_V (\text{div } \rho \mathbf{v}) dV, \quad (7.5.4)$$

thus, Eq. (7.5.2) can be written as

$$\int_{V_c} \left[\frac{\partial \rho}{\partial t} + \text{div } (\rho \mathbf{v}) \right] dV = 0. \quad (7.5.5)$$

This equation is to be valid for all V_c ; therefore, we must have

$$\frac{\partial \rho}{\partial t} + \text{div } (\rho \mathbf{v}) = 0, \quad (7.5.6)$$

or

$$\frac{D\rho}{Dt} + \rho \text{div } \mathbf{v} = 0. \quad (7.5.7)$$

Eq. (7.5.6) or Eq. (7.5.7) is the same equation of continuity derived in Section 3.15.

Example 7.5.1

Given the motion

$$x_1 = (1 + \alpha t)X_1, \quad x_2 = X_2, \quad x_3 = X_3 \quad (\text{i})$$

and the density field

$$\rho = \frac{\rho_0}{1 + \alpha t} \quad (\rho_0 = \text{constant}). \quad (\text{ii})$$

- (a) Obtain the velocity field.
 (b) Check that the equation of continuity is satisfied.
 (c) Compute the total mass and the rate of increase of mass inside a cylindrical control volume of cross-sectional area A and having as its end faces the plane $x_1 = 1$ and $x_1 = 3$.
 (d) Compute the net rate of inflow of mass into the control volume of part (c).
 (e) Find the total mass at time t of the material that at the reference time ($t = 0$) was in the control volume of (c).
 (f) Compute the total linear momentum for the fixed part of material considered in part (e).

Solution

(a)

$$v_1 = \frac{Dx_1}{Dt} = \alpha X_1 = \frac{\alpha x_1}{1 + \alpha t}, \quad v_2 = 0, \quad v_3 = 0. \quad (\text{iii})$$

(b) Using (ii) and (iii),

$$\frac{D\rho}{Dt} + \rho(\text{div } \mathbf{v}) = \frac{\partial \rho}{\partial t} + v_1 \frac{\partial \rho}{\partial x_1} + \rho \frac{\partial v_1}{\partial x_1} = -\frac{\alpha \rho_0}{(1 + \alpha t)^2} + \frac{\alpha x_1}{(1 + \alpha t)} (0) + \frac{\rho_0}{(1 + \alpha t)} \frac{\alpha}{(1 + \alpha t)} = 0. \quad (\text{iv})$$

(c) The total mass inside the control volume at time t is

$$m(t) = \int_{V_c} \rho(x, t) dV = \int_{x_1=1}^{x_1=3} \rho(x, t) dV = \int_{x_1=1}^{x_1=3} \frac{\rho_0}{1 + \alpha t} A dx_1 = \frac{2A\rho_0}{1 + \alpha t}, \quad (\text{v})$$

and the rate at which the mass is increasing inside the control volume at time t is

$$\frac{\partial m}{\partial t} = -\frac{2\alpha A\rho_0}{(1 + \alpha t)^2}. \quad (\text{vi})$$

The negative sign means that the mass is decreasing.

(d) Since $v_2 = v_3 = 0$, there is neither inflow nor outflow through the lateral surface of the control volume. Through the end face $x_1 = 1$, the rate of inflow (mass influx) is

$$(\rho Av)_{x_1=1} = \rho_0 \alpha A / (1 + \alpha t)^2. \quad (\text{vii})$$

On the other hand, the mass outflux through the end face $x_1 = 3$ is

$$(\rho Av)_{x_1=3} = 3\rho_0 \alpha A / (1 + \alpha t)^2. \quad (\text{viii})$$

Thus, the net mass influx is

$$\frac{\partial m}{\partial t} = -\frac{2\rho_0\alpha A}{(1+\alpha t)^2}, \quad (\text{ix})$$

which is the same as Eq. (vi).

- (e) The particles that were at $x_1 = 1$ and $x_1 = 3$ when $t = 0$ have the material coordinates $X_1 = 1$ and $X_1 = 3$, respectively. Thus, the total mass at time t is

$$M = \int_{x_1=(1+\alpha t)}^{x_1=3(1+\alpha t)} \frac{\rho_0}{1+\alpha t} A dx_1 = \frac{A\rho_0}{1+\alpha t} [3(1+\alpha t) - (1+\alpha t)] = 2A\rho_0. \quad (\text{x})$$

We see that this time-dependent integral turns out to be independent of time. This is because the chosen density and velocity fields satisfy the equation of continuity so that the total mass of a fixed part of material is indeed a constant.

- (f) Total linear momentum is, since $v_2 = v_3 = 0$,

$$\mathbf{P} = \int_{x_1=(1+\alpha t)}^{x_1=3(1+\alpha t)} \rho v_1 A dx_1 \mathbf{e}_1 = \frac{A\rho_0\alpha}{(1+\alpha t)^2} \int_{(1+\alpha t)}^{3(1+\alpha t)} x_1 dx_1 \mathbf{e}_1 = 4A\rho_0\alpha \mathbf{e}_1. \quad (\text{xi})$$

The fact that \mathbf{P} is also a constant is accidental. The given motion happens to be acceleration-less, which corresponds to no net force acting on the material volume. In general, the linear momentum for a fixed part of material is a function of time.

7.6 THE PRINCIPLE OF LINEAR MOMENTUM

The *global principle of linear momentum* states that the total force (surface and body forces) acting on any fixed part of material is equal to the rate of change of linear momentum of the part. That is, with ρ denoting density, \mathbf{v} velocity, \mathbf{t} stress vector, and \mathbf{B} body force per unit mass, the principle states

$$\int_{S_c} \mathbf{t} dS + \int_{V_c} \rho \mathbf{B} dV = \frac{D}{Dt} \int_{V_m} \rho \mathbf{v} dV. \quad (7.6.1)$$

Now, using the Reynolds transport theorem Eq. (7.4.1), Eq. (7.6.1) can be written as

$$\int_{S_c} \mathbf{t} dS + \int_{V_c} \rho \mathbf{B} dV = \int_{V_c} \frac{\partial \rho \mathbf{v}}{\partial t} dV + \int_{S_c} \rho \mathbf{v} (\mathbf{v} \cdot \mathbf{n}) dS. \quad (7.6.2)$$

In words, Eq. (7.6.2) states that:

Total force exerted on a fixed part of a material instantaneously in a control volume V_c = time rate of change of total linear momentum inside the control volume + net outflux of linear momentum through the control surface S_c .

Equation (7.6.2) is very useful for obtaining approximate results in many engineering problems. Using Eq. (7.4.11), Eq. (7.6.2) can also be written as

$$\int_{V_c} \left[\frac{D(\rho \mathbf{v})}{Dt} + \rho \mathbf{v} (\text{div } \mathbf{v}) \right] dV = \int_{S_c} \mathbf{t} dS + \int_{V_c} \rho \mathbf{B} dV. \quad (7.6.3)$$

But

$$\frac{D(\rho \mathbf{v})}{Dt} = \frac{D\rho}{Dt} \mathbf{v} + \rho \frac{D\mathbf{v}}{Dt} = -(\rho \operatorname{div} \mathbf{v}) \mathbf{v} + \rho \frac{D\mathbf{v}}{Dt}, \quad (7.6.4)$$

where we have made use of the conservation of mass equation $D\rho/Dt + \rho \operatorname{div} \mathbf{v} = 0$; therefore, Eq. (7.6.3) becomes

$$\int_{V_c} \rho \frac{D\mathbf{v}}{Dt} dV = \int_{S_c} \mathbf{t} dS + \int_{V_c} \rho \mathbf{B} dV. \quad (7.6.5)$$

Since

$$\int_{S_c} \mathbf{t} dS = \int_{S_c} \mathbf{T} \mathbf{n} dS = \int_{V_c} \operatorname{div} \mathbf{T} dV, \quad (7.6.6)$$

we have

$$\int_{V_c} \left(\rho \frac{D\mathbf{v}}{Dt} - \operatorname{div} \mathbf{T} - \rho \mathbf{B} \right) dV = 0, \quad (7.6.7)$$

from which the following field equation of motion is obtained:

$$\rho \frac{D\mathbf{v}}{Dt} = \operatorname{div} \mathbf{T} + \rho \mathbf{B}. \quad (7.6.8)$$

This is the same equation of motion derived in Chapter 4 (see Section 4.7).

We can also obtain the equation of motion in the reference state as follows: Let ρ_o , dS_o , and dV_o denote the density, surface area, and volume, respectively, at the reference time t_o for the differential material having ρ , dS , and dV at time t ; then the conservation of mass principle gives

$$\rho_o dV_o = \rho dV, \quad (7.6.9)$$

and the definition of the stress vector \mathbf{t}_o , associated with the first Piola-Kirchhoff stress tensor \mathbf{T}_o , gives [see Eq. (4.10.6)]

$$\mathbf{t}_o dS_o = \mathbf{t} dS. \quad (7.6.10)$$

Now, using Eqs. (7.6.9) and (7.6.10), Eq. (7.6.5) can be transformed to the reference configuration. That is,

$$\int_{V_o} \rho_o \frac{D\mathbf{v}}{Dt} dV_o = \int_{S_o} \mathbf{t}_o dS_o + \int_{V_o} \rho_o \mathbf{B} dV_o = \int_{S_o} \mathbf{T}_o \mathbf{n}_o dS_o + \int_{V_o} \rho_o \mathbf{B} dV_o. \quad (7.6.11)$$

In the preceding equation, everything is a function of the material coordinates X_i and t , \mathbf{T}_o is the first Piola-Kirchhoff stress tensor, and \mathbf{n}_o is the outward normal. Using the divergence theorem for the stress tensor term, Eq. (7.6.11) becomes

$$\int_{V_o} \rho_o \frac{D\mathbf{v}}{Dt} dV_o = \int_{V_o} \operatorname{Div} \mathbf{T}_o dV_o + \int_{V_o} \rho_o \mathbf{B} dV_o, \quad (7.6.12)$$

where, in Cartesian coordinates,

$$\operatorname{Div} \mathbf{T}_o = \left[\partial(T_o)_{ij} / \partial X_j \right] \mathbf{e}_i. \quad (7.6.13)$$

From Eq. (7.6.12), we obtain

$$\rho_o \frac{D\mathbf{v}}{Dt} = \text{Div } \mathbf{T}_o + \rho_o \mathbf{B}. \quad (7.6.14)$$

This is the same equation derived in Chapter 4, Eq. (4.11.2).

Example 7.6.1

A homogeneous rope of total length ℓ and total mass m slides down from the corner of a smooth table. Find the motion of the rope and tension at the corner.

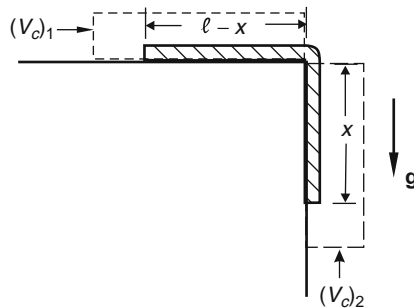

FIGURE 7.6-1

Solution

Let x denote the portion of rope that has slid down the corner at time t . Then the portion that remains on the table at time t is $\ell - x$. Consider the control volume shown as $(V_c)_1$ in Figure 7.6-1. The momentum in the horizontal direction inside the control volume at any time t is, with \dot{x} denoting dx/dt , $\frac{m}{\ell}(\ell - x)\dot{x}$, and the net momentum outflux is $\left[\frac{m}{\ell}\dot{x}\right]\dot{x}$. Thus, if T denotes the tension at the corner point of the rope at time t , we have

$$T = \frac{d}{dt} \left[\frac{m}{\ell}(\ell - x)\dot{x} \right] + \frac{m}{\ell}\dot{x}^2 = \frac{m}{\ell}(-\dot{x})\dot{x} + \frac{m}{\ell}(\ell - x)\ddot{x} + \frac{m}{\ell}\dot{x}^2, \quad (i)$$

i.e.,

$$T = \frac{m}{\ell}(\ell - x)\ddot{x}, \quad (ii)$$

as expected.

On the other hand, by considering the control volume $(V_c)_2$ (see Figure 7.6-1), the momentum in the downward direction is $(m/\ell)x\dot{x}$ and the momentum influx in the same direction is $[(m/\ell)\dot{x}]\dot{x}$. Thus,

$$-T + \left(\frac{m}{\ell}x\right)g = \frac{d}{dt} \left(\frac{m}{\ell}x\dot{x} \right) - \frac{m}{\ell}\dot{x}^2, \quad (iii)$$

i.e.,

$$-T + \frac{m}{\ell}xg = \frac{m}{\ell}x\ddot{x}. \quad (\text{iv})$$

From Eqs. (ii) and (iv), we have

$$\frac{m}{\ell}(\ell - x)\ddot{x} = \frac{m}{\ell}xg - \frac{m}{\ell}x\ddot{x}, \quad (\text{v})$$

i.e.,

$$\ddot{x} - \frac{g}{\ell}x = 0. \quad (\text{vi})$$

The general solution of Eq. (vi) is

$$x = C_1 \exp\left[\left(\sqrt{g/\ell}\right)t\right] + C_2 \exp\left[\left(-\sqrt{g/\ell}\right)t\right]. \quad (\text{vii})$$

If the rope starts at rest with an initial overhang of x_0 , we have

$$x = \frac{x_0}{2} \left\{ \exp\left[\left(\sqrt{g/\ell}\right)t\right] + \exp\left[-\left(\sqrt{g/\ell}\right)t\right] \right\}. \quad (\text{viii})$$

The tension at the corner is given by

$$T = \frac{m}{\ell}(\ell - x)\ddot{x} = \frac{m}{\ell}(\ell - x)\left(\frac{gx}{\ell}\right). \quad (\text{ix})$$

We note that the motion can also be obtained by considering the whole rope as a system. In fact, the total linear momentum of the rope at any time t is

$$\frac{m}{\ell}(\ell - x)\dot{x}\mathbf{e}_1 + \frac{m}{\ell}x\dot{x}\mathbf{e}_2. \quad (\text{x})$$

Its rate of change is

$$\frac{m}{\ell} \left[(\ell - x)\ddot{x} - \dot{x}^2 \right] \mathbf{e}_1 + \frac{m}{\ell} \left(x\ddot{x} + \dot{x}^2 \right) \mathbf{e}_2, \quad (\text{xi})$$

and the total resultant force on the rope is $(m/\ell)xg \mathbf{e}_2$. Thus, equating the force to the rate of change of momentum for the whole rope, we obtain

$$(\ell - x)\ddot{x} - \dot{x}^2 = 0 \quad (\text{xii})$$

and

$$\ddot{x}x + \dot{x}^2 = gx. \quad (\text{xiii})$$

Eliminating \dot{x}^2 from the preceding two equations, we arrive at Eq. (vi) again.

Example 7.6.2

Figure 7.6-2 shows a steady jet of water impinging onto a curved vane in a tangential direction. Neglect the effect of weight and assume that the flow at the upstream region, section A , as well as at the downstream region, section B , is a parallel flow with a uniform speed v_0 . Find the resultant force (over that due to the atmospheric pressure) exerted on the vane by the jet. The volume flow rate is Q .

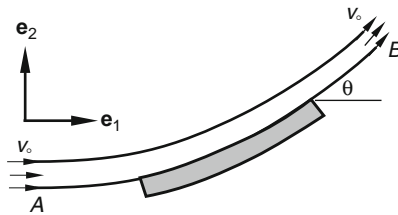
**FIGURE 7.6-2****Solution**

Let us take as a control volume that portion of the jet bounded by the planes at A and B . Since the flow at A is assumed to be a parallel flow of uniform speed, the stress vector on the plane A is normal to the plane with a magnitude equal to the atmospheric pressure, which we take to be zero. The same is true on the plane B . Thus, the only force acting on the material in the control volume is that from the vane to the jet. Let \mathbf{F} be the resultant of these forces. Since the flow is steady, the rate of increase of momentum inside the control volume is zero. The rate of out flow of linear momentum across B is $\rho Q v_0 (\cos \theta \mathbf{e}_1 + \sin \theta \mathbf{e}_2)$ and the rate of inflow of linear momentum across A is $\rho Q v_0 \mathbf{e}_1$. Thus,

$$\mathbf{F} = \rho Q [v_0 (\cos \theta - 1) \mathbf{e}_1 + v_0 \sin \theta \mathbf{e}_2].$$

The force on the vane by the jet is equal and opposite to that given above.

Example 7.6.3

For a boundary layer flow of water over a flat plate, if the velocity profile of the horizontal components at the leading and the trailing edges of the plate, respectively, are assumed to be those shown in Figure 7.6-3, find the shear force acting on the fluid by the plate. Assume that the flow is steady and that the pressure is uniform in the whole flow field.

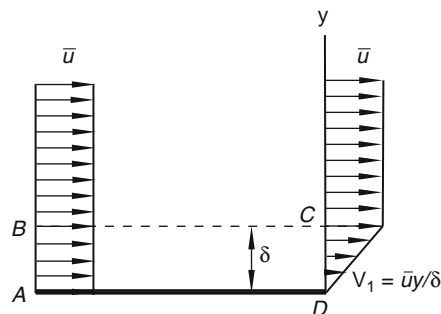
**FIGURE 7.6-3**

Solution

Consider the control volume $ABCD$. Since the pressure is assumed to be uniform and since the flow outside the boundary layer δ is essentially uniform in horizontal velocity components (in x direction) with very small vertical velocity components (so that the shearing stress on BC is negligible), the net force on the control volume is the shearing force from the plate. Denoting this force (per unit width in z direction) $F\mathbf{e}_1$, we have, from the momentum principle, F = net outflux of x momentum through $ABCD$. Thus,

$$F = \int_{S_c} v_1(\rho \mathbf{v} \cdot \mathbf{n}) dS = - \int_0^\delta \bar{u}(\rho \bar{u}) dy + \int_{BC} \bar{u}(\rho v_2) dS + \int_0^\delta \left(\frac{\bar{u}y}{\delta}\right) \rho \left(\frac{\bar{u}y}{\delta}\right) dy + \int_{AD} (0) dS, \quad (i)$$

where \bar{u} denotes the uniform horizontal velocity of the upstream flow and the uniform horizontal velocity component beyond the boundary layer at the trailing edge, v_1 and v_2 are the horizontal and vertical velocity components of the fluid particles, respectively, and δ is the thickness of the boundary layer. Thus,

$$F = -\rho \bar{u}^2 \delta + \bar{u} \int_{BC} \rho v_2 dS + \frac{\rho \bar{u}^2 \delta}{3}. \quad (ii)$$

From the principle of conservation of mass, we have

$$\int_{BC} \rho v_2 dS - \int_0^\delta \rho \bar{u} dy + \int_0^\delta \rho \frac{\bar{u}y}{\delta} dy = 0, \quad (iii)$$

i.e.,

$$\int_{BC} \rho v_2 dS = \rho \bar{u} \delta - \frac{\rho \bar{u} \delta}{2} = \frac{\rho \bar{u} \delta}{2}. \quad (iv)$$

Thus,

$$F = -\rho \bar{u}^2 \delta + \frac{\rho \bar{u}^2 \delta}{2} + \frac{\rho \bar{u}^2 \delta}{3} = -\frac{\rho \bar{u}^2 \delta}{6}. \quad (v)$$

That is, the force per unit width on the fluid by the plate is acting to the left with a magnitude of $\rho \bar{u}^2 \delta / 6$.

7.7 MOVING FRAMES

There are certain problems for which the use of a control volume fixed with respect to a frame moving relative to an inertial frame is advantageous. For this purpose, we derive the momentum principle valid for a frame moving relative to an inertial frame.

Let F_1 and F_2 be two frames of references. Let \mathbf{r} denote the position vector of a differential mass dm in a continuum relative to F_1 , and let \mathbf{x} denote the position vector relative to F_2 (see Figure 7.7-1). The velocity of dm relative to F_1 is

$$\left(\frac{d\mathbf{r}}{dt}\right)_{F_1} \equiv \mathbf{v}_{F_1}, \quad (7.7.1)$$

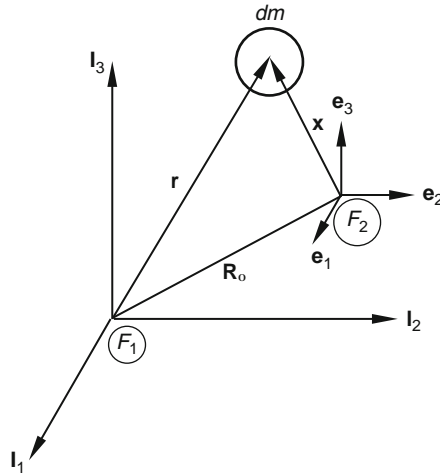

FIGURE 7.7-1

and the velocity relative to F_2 is

$$\left(\frac{dx}{dt}\right)_{F_2} \equiv \mathbf{v}_{F_2}. \quad (7.7.2)$$

Since

$$\mathbf{r} = \mathbf{R}_o + \mathbf{x}, \quad (7.7.3)$$

then

$$\left(\frac{d\mathbf{r}}{dt}\right)_{F_1} = \left(\frac{d\mathbf{R}_o}{dt}\right)_{F_1} + \left(\frac{d\mathbf{x}}{dt}\right)_{F_1}, \quad (7.7.4)$$

i.e.,

$$\mathbf{v}_{F_1} = (\mathbf{v}_o)_{F_1} + \left(\frac{d\mathbf{x}}{dt}\right)_{F_1}. \quad (7.7.5)$$

Now, for any vector \mathbf{b} , we have

$$\left(\frac{d\mathbf{b}}{dt}\right)_{F_1} = \left(\frac{d\mathbf{b}}{dt}\right)_{F_2} + \boldsymbol{\omega} \times \mathbf{b}, \quad (7.7.6)$$

where $\boldsymbol{\omega}$ is the angular velocity of F_2 relative to F_1 . Thus,

$$\left(\frac{d\mathbf{x}}{dt}\right)_{F_1} = \left(\frac{d\mathbf{x}}{dt}\right)_{F_2} + \boldsymbol{\omega} \times \mathbf{x} = (\mathbf{v})_{F_2} + \boldsymbol{\omega} \times \mathbf{x}, \quad (7.7.7)$$

and Eq. (7.7.5) becomes

$$\mathbf{v}_{F_1} = (\mathbf{v}_o)_{F_1} + \mathbf{v}_{F_2} + \boldsymbol{\omega} \times \mathbf{x}. \quad (7.7.8)$$

The linear momentum relative to F_1 is $\int \mathbf{v}_{F_1} dm$ and that relative to F_2 is $\int \mathbf{v}_{F_2} dm$. The rates of change of linear momentum are related in the following way (for simplicity, we drop the subscript of the integrals):

$$\begin{aligned} \left(\frac{D}{Dt}\right)_{F_1} \int \mathbf{v}_{F_1} dm &= \left(\frac{D}{Dt}\right)_{F_1} \left[(\mathbf{v}_o)_{F_1} \int dm + \int \mathbf{v}_{F_2} dm + \boldsymbol{\omega} \times \int \mathbf{x} dm \right] \\ &= (\mathbf{a}_o)_{F_1} \int dm + \left(\frac{D}{Dt}\right)_{F_1} \int \mathbf{v}_{F_2} dm + \left(\frac{D}{Dt}\right)_{F_1} \left(\boldsymbol{\omega} \times \int \mathbf{x} dm \right), \end{aligned} \quad (7.7.9)$$

where $(\mathbf{a}_o)_{F_1}$ is the acceleration with respect to the frame F_1 . Using Eq. (7.7.6) again, we have

$$\left(\frac{D}{Dt}\right)_{F_1} \int \mathbf{v}_{F_2} dm = \left(\frac{D}{Dt}\right)_{F_2} \int \mathbf{v}_{F_2} dm + \boldsymbol{\omega} \times \int \mathbf{v}_{F_2} dm, \quad (7.7.10)$$

and

$$\begin{aligned} \left(\frac{D}{Dt}\right)_{F_1} \left(\boldsymbol{\omega} \times \int \mathbf{x} dm \right) &= \dot{\boldsymbol{\omega}} \times \int \mathbf{x} dm + \boldsymbol{\omega} \times \int \left(\frac{D\mathbf{x}}{Dt}\right)_{F_1} dm \\ &= \dot{\boldsymbol{\omega}} \times \int \mathbf{x} dm + \boldsymbol{\omega} \times \int \mathbf{v}_{F_2} dm + \boldsymbol{\omega} \times \left(\boldsymbol{\omega} \times \int \mathbf{x} dm \right). \end{aligned} \quad (7.7.11)$$

Thus,

$$\begin{aligned} \left(\frac{D}{Dt}\right)_{F_1} \int \mathbf{v}_{F_1} dm &= (\mathbf{a}_o)_{F_1} \int dm + \left(\frac{D}{Dt}\right)_{F_2} \int \mathbf{v}_{F_2} dm + 2\boldsymbol{\omega} \times \int \mathbf{v}_{F_2} dm \\ &\quad + \dot{\boldsymbol{\omega}} \times \int \mathbf{x} dm + \boldsymbol{\omega} \times \left(\boldsymbol{\omega} \times \int \mathbf{x} dm \right). \end{aligned} \quad (7.7.12)$$

Now let F_1 be an inertial frame. The momentum principle then reads:

$$\left(\frac{D}{Dt}\right)_{F_1} \int \mathbf{v}_{F_1} dm = \int \mathbf{t} dS + \int \rho \mathbf{B} dV. \quad (7.7.13)$$

From Eqs. (7.7.12) and (7.7.13), we have

$$\begin{aligned} \left(\frac{D}{Dt}\right)_{F_2} \int \mathbf{v}_{F_2} dm &= \int \mathbf{t} dS + \int \rho \mathbf{B} dV \\ &\quad - \left[m(\mathbf{a}_o) + 2\boldsymbol{\omega} \times \int \mathbf{v}_{F_2} dm + \dot{\boldsymbol{\omega}} \times \int \mathbf{x} dm + \boldsymbol{\omega} \times \left(\boldsymbol{\omega} \times \int \mathbf{x} dm \right) \right], \end{aligned} \quad (7.7.14)$$

where $m = \int dm$, $(\mathbf{a}_o) \equiv (\mathbf{a}_o)_{F_1}$ is the acceleration of the point o with respect to the inertia frame, and $\boldsymbol{\omega}$ and $\dot{\boldsymbol{\omega}}$ are angular velocity and angular acceleration of the frame 2 relative to the inertia frame.

Eq. (7.7.14) shows that when a moving frame is used to compute momentum and its time rate of change, the same momentum principle for an inertial frame can be used *provided that we include the effect of the moving frame through the terms inside the bracket in the right-hand side of Eq. (7.7.14)*.

7.8 A CONTROL VOLUME FIXED WITH RESPECT TO A MOVING FRAME

If a control volume is chosen to be fixed with respect to a frame of reference that moves relative to an inertial frame with an acceleration \mathbf{a}_o , an angular velocity $\boldsymbol{\omega}$, and angular acceleration $\dot{\boldsymbol{\omega}}$, the momentum equation is given by Eq. (7.7.14). If we now use the Reynolds transport theorem for the left-hand side of Eq. (7.7.14), we obtain

$$\int_{V_c} \frac{\partial}{\partial t} (\rho \mathbf{v}_{F_2}) dV + \int_{S_c} \rho \mathbf{v}_{F_2} (\mathbf{v}_{F_2} \cdot \mathbf{n}) dS = \int_{S_c} \mathbf{t} dS + \int_{V_c} \rho \mathbf{B} dV - \left[m(\mathbf{a}_o)_F + 2\boldsymbol{\omega} \times \int_{V_c} \mathbf{v}_{F_2} dm + \dot{\boldsymbol{\omega}} \times \int_{V_c} \mathbf{x} dm + \boldsymbol{\omega} \times \left(\boldsymbol{\omega} \times \int_{V_c} \mathbf{x} dm \right) \right]. \quad (7.8.1)$$

In particular, if the control volume has only translation (with acceleration = \mathbf{a}_o) with respect to the inertial frame, then we have

$$\int_{V_c} \frac{\partial}{\partial t} (\rho \mathbf{v}_{F_2}) dV + \int_{S_c} \rho \mathbf{v}_{F_2} (\mathbf{v}_{F_2} \cdot \mathbf{n}) dS = \int_{S_c} \mathbf{t} dS + \int_{V_c} \rho \mathbf{B} dV - m(\mathbf{a}_o)_F. \quad (7.8.2)$$

7.9 THE PRINCIPLE OF MOMENT OF MOMENTUM

The *global principle of moment of momentum* states that the total moment about a fixed point of surface and body forces on a fixed part of material is equal to the time rate of change of total moment of momentum of the part about the same point. That is,

$$\frac{D}{Dt} \int_{V_m} \mathbf{x} \times \rho \mathbf{v} dV = \int_{S_c} (\mathbf{x} \times \mathbf{t}) dS + \int_{V_c} (\mathbf{x} \times \rho \mathbf{B}) dV, \quad (7.9.1)$$

where \mathbf{x} is the position vector for a general particle.

Using the Reynolds transport theorem, Eq. (7.4.2), the left-hand side of the preceding equation, Eq. (7.9.1), becomes

$$\frac{D}{Dt} \int_{V_m} \mathbf{x} \times \rho \mathbf{v} dV = \int_{V_c} \frac{D}{Dt} (\mathbf{x} \times \rho \mathbf{v}) dV + \int_{V_c} (\mathbf{x} \times \rho \mathbf{v}) (\text{div } \mathbf{v}) dV. \quad (7.9.2)$$

Since

$$\frac{D}{Dt} (\mathbf{x} \times \rho \mathbf{v}) = \mathbf{v} \times \rho \mathbf{v} + \mathbf{x} \times \left(\frac{D\rho}{Dt} \right) \mathbf{v} + \mathbf{x} \times \rho \frac{D\mathbf{v}}{Dt} = \mathbf{x} \times \left(\frac{D\rho}{Dt} \right) \mathbf{v} + \mathbf{x} \times \rho \frac{D\mathbf{v}}{Dt}, \quad (7.9.3)$$

the sum of the integrands on the right side of Eq. (7.9.2) becomes

$$\mathbf{x} \times \left(\frac{D\rho}{Dt} + \rho \text{div } \mathbf{v} \right) \mathbf{v} + \mathbf{x} \times \rho \frac{D\mathbf{v}}{Dt} = \mathbf{x} \times \rho \frac{D\mathbf{v}}{Dt}. \quad (7.9.4)$$

Thus,

$$\frac{D}{Dt} \int_{V_m} \mathbf{x} \times \rho \mathbf{v} dV = \int_{V_c} \left(\mathbf{x} \times \rho \frac{D\mathbf{v}}{Dt} \right) dV. \quad (7.9.5)$$

Also, from Eq. (7.2.13), we have

$$\int_{S_c} (\mathbf{x} \times \mathbf{t}) dS = \int_{V_c} [\mathbf{x} \times (\operatorname{div} \mathbf{T}) + 2\mathbf{t}^A] dV.$$

Using Eqs. (7.9.5) and (7.2.13), Eq. (7.9.1) becomes

$$\int_{V_c} \mathbf{x} \times \left[\rho \frac{D\mathbf{v}}{Dt} - \operatorname{div} \mathbf{T} - \rho \mathbf{B} \right] dV - 2 \int_{V_c} \mathbf{t}^A dV = 0, \quad (7.9.6)$$

where \mathbf{t}^A is the axial vector of the antisymmetric part of the stress tensor \mathbf{T} . Now the first term in Eq. (7.9.6) vanishes because of Eq. (7.6.8); therefore, $\mathbf{t}^A = 0$ and the symmetry of the stress tensor

$$\mathbf{T} = \mathbf{T}^T \quad (7.9.7)$$

is obtained.

On the other hand, if we use the Reynolds transport theorem, Eq. (7.4.1), for the left-hand side of Eq. (7.9.1), we obtain

$$\int_{S_c} (\mathbf{x} \times \mathbf{t}) dS + \int_{V_c} (\mathbf{x} \times \rho \mathbf{B}) dV = \int_{V_c} \frac{\partial}{\partial t} (\mathbf{x} \times \rho \mathbf{v}) dV + \int_{S_c} (\mathbf{x} \times \rho \mathbf{v})(\mathbf{v} \cdot \mathbf{n}) dS. \quad (7.9.8)$$

That is, the total moment about a fixed point due to surface and body forces acting on the material instantaneously inside a control volume = total rate of change of moment of momentum inside the control volume + total net rate of outflow of moment of momentum across the control surface.

If the control volume is fixed in a moving frame, then the following terms should be added to the left side of Eq. (7.9.8):

$$-\left(\int \mathbf{x} dm \right) \times \mathbf{a}_o - \int \mathbf{x} \times (\dot{\boldsymbol{\omega}} \times \mathbf{x}) dm - \int \mathbf{x} \times [\boldsymbol{\omega} \times (\boldsymbol{\omega} \times \mathbf{x})] dm - 2 \int \mathbf{x} \times (\boldsymbol{\omega} \times \mathbf{v}) dm, \quad (7.9.9)$$

where $\boldsymbol{\omega}$ and $\dot{\boldsymbol{\omega}}$ are absolute angular velocity and acceleration of the moving frame (and of the control volume), the vector \mathbf{x} of dm is measured from an arbitrary chosen point O in the control volume, \mathbf{a}_o is the absolute acceleration of point O , and \mathbf{v} is the velocity of dm relative to the control volume.

Example 7.9.1

Each sprinkler arm in Figure 7.9-1 discharges a constant volume of water Q per unit time and is free to rotate around the vertical center axis. Determine its constant speed of rotation.

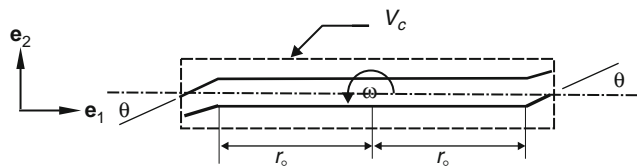

FIGURE 7.9-1

Solution

Let V_c be a control volume that rotates with the sprinkler arms. The velocity of water particles relative to the sprinkler is $(Q/A)\mathbf{e}_1$ inside the right arm and $(Q/A)(-\mathbf{e}_1)$ inside the left arm. If ρ is density, then the total net outflux of moment of momentum about point O is

$$2\rho Q \frac{Q}{A} \sin \theta r_0 \mathbf{e}_3. \quad (\text{i})$$

The moment of momentum about O due to weight is zero. Since the pressure in the water jet is the same as the atmospheric pressure, taken to be zero gauge pressure, there is no contribution due to surface force on the control volume. Now, since the control volume is rotating with the sprinkler, we need to add those terms given in Eq. (7.9.9) to the moments of forces. With x measured from O , the first term in Eq. (7.9.9) is zero. With $\boldsymbol{\omega}$ a constant, the second term in that equation is also zero. With $\mathbf{x} = x_1\mathbf{e}_1$ and $\boldsymbol{\omega} = \omega_3\mathbf{e}_3$, the third term is also zero. Thus, the only nonzero term is

$$-2 \int \mathbf{x} \times (\boldsymbol{\omega} \times \mathbf{v}) dm, \quad (\text{ii})$$

which is the moment due to the Coriolis forces. Now, for the right arm, $\mathbf{v} = (Q/A)\mathbf{e}_1$; therefore,

$$\mathbf{x} \times (\boldsymbol{\omega} \times \mathbf{v}) = x\mathbf{e}_1 \times \left(\omega\mathbf{e}_3 \times \frac{Q}{A}\mathbf{e}_1 \right) = x\mathbf{e}_1 \times \frac{\omega Q}{A}\mathbf{e}_2 = \frac{x\omega Q}{A}\mathbf{e}_3. \quad (\text{iii})$$

Thus, the contribution from the fluid in the right arm to the integral in the expression (ii) is

$$-\frac{2\omega Q}{A}\mathbf{e}_3 \int_0^{r_0} x(\rho A dx) = -\omega Q \rho r_0^2 \mathbf{e}_3. \quad (\text{iv})$$

Including that due to the left arm, the integral has the value of $-2\omega Q \rho r_0^2 \mathbf{e}_3$. Therefore, from the moment of momentum principle for a moving control volume, we have

$$2\rho Q \left(\frac{Q}{A} \right) \sin \theta r_0 = -2\omega Q \rho r_0^2, \quad (\text{v})$$

from which we have

$$\omega = -\left(\frac{Q}{A} \right) \frac{\sin \theta}{r_0}. \quad (\text{vi})$$

7.10 THE PRINCIPLE OF CONSERVATION OF ENERGY

The *principle of conservation of energy* states that the time rate of increase of the kinetic energy and internal energy for a fixed part of material is equal to the sum of the rate of work done by the surface and body forces, the heat energy entering the boundary surface, and the heat supply throughout the volume. That is, if v^2 denotes $(\mathbf{v} \cdot \mathbf{v})$, u the internal energy per unit mass, \mathbf{q} the heat flux vector (i.e., rate of heat flow per unit area across the boundary surface), and q_s the heat supply per unit mass, then the principle states:

$$\frac{D}{Dt} \int_{V_m} \left(\frac{\rho v^2}{2} + \rho u \right) dV = \int_{S_c} (\mathbf{t} \cdot \mathbf{v}) dS + \int_{V_c} \rho \mathbf{B} \cdot \mathbf{v} dV - \int_{S_c} (\mathbf{q} \cdot \mathbf{n}) dS + \int_{V_c} \rho q_s dV. \quad (7.10.1)$$

The minus sign in the term with $(\mathbf{q} \cdot \mathbf{n})$ is due to the convention that \mathbf{n} is an outward unit normal vector and therefore $(-\mathbf{q} \cdot \mathbf{n})$ represents inflow.

Again, using the Reynolds transport theorem, Eq. (7.4.2), the left side of the preceding equation becomes

$$\begin{aligned} \frac{D}{Dt} \int_{V_m} \rho \left(\frac{v^2}{2} + u \right) dV &= \int_{V_c} \left[\frac{D}{Dt} \rho \left(\frac{v^2}{2} + u \right) + \rho \left(\frac{v^2}{2} + u \right) \operatorname{div} \mathbf{v} \right] dV \\ &= \int_{V_c} \left[\rho \frac{D}{Dt} \left(\frac{v^2}{2} + u \right) + \left(\frac{v^2}{2} + u \right) \left(\frac{D\rho}{Dt} + \rho \operatorname{div} \mathbf{v} \right) \right] dV = \int_{V_c} \left[\rho \frac{D}{Dt} \left(\frac{v^2}{2} + u \right) \right] dV. \end{aligned} \quad (7.10.2)$$

We have previously obtained [see Eq. (7.2.17)]

$$\int_{S_c} \mathbf{t} \cdot \mathbf{v} dS = \int_{V_c} [(\operatorname{div} \mathbf{T}) \cdot \mathbf{v} + \operatorname{tr}(\mathbf{T}^T \nabla \mathbf{v})] dV,$$

and the divergence theorem gives [see Eq. (7.2.5)]

$$\int_{S_c} \mathbf{q} \cdot \mathbf{n} dS = \int_{V_c} (\operatorname{div} \mathbf{q}) dV.$$

Using Eqs. (7.10.2), (7.2.17), and (7.2.5), Eq. (7.10.1) becomes

$$\int_{V_c} \rho \frac{D}{Dt} \left(\frac{v^2}{2} + u \right) dV = \int_{V_c} [(\operatorname{div} \mathbf{T} + \rho \mathbf{B}) \cdot \mathbf{v} + \operatorname{tr}(\mathbf{T}^T \nabla \mathbf{v}) - \operatorname{div} \mathbf{q} + \rho q_s] dV. \quad (7.10.3)$$

Since

$$(\operatorname{div} \mathbf{T} + \rho \mathbf{B}) \cdot \mathbf{v} = \rho \frac{D\mathbf{v}}{Dt} \cdot \mathbf{v} = \frac{1}{2} \rho \frac{Dv^2}{Dt}, \quad (7.10.4)$$

Eq. (7.10.3) becomes

$$\int_{V_c} \rho \frac{Du}{Dt} dV = \int_{V_c} [\operatorname{tr}(\mathbf{T}^T \nabla \mathbf{v}) - \operatorname{div} \mathbf{q} + \rho q_s] dV. \quad (7.10.5)$$

Thus, at every point, we have

$$\rho \frac{Du}{Dt} = \operatorname{tr}(\mathbf{T}^T \nabla \mathbf{v}) - \operatorname{div} \mathbf{q} + \rho q_s. \quad (7.10.6)$$

For a symmetric tensor \mathbf{T} , this equation can also be written

$$\rho \frac{Du}{Dt} = \operatorname{tr}(\mathbf{T} \nabla \mathbf{v}) - \operatorname{div} \mathbf{q} + \rho q_s. \quad (7.10.7)$$

Eq. (7.10.6) or Eq. (7.10.7) is the energy equation. A slightly different form of Eq. (7.10.7) can be obtained if we recall that $\nabla \mathbf{v} = \mathbf{D} + \mathbf{W}$, where \mathbf{D} , the symmetric part of $\nabla \mathbf{v}$, is the rate of deformation tensor and \mathbf{W} , the antisymmetric part of $\nabla \mathbf{v}$, is the spin tensor. We have

$$\operatorname{tr}(\mathbf{T} \nabla \mathbf{v}) = \operatorname{tr}(\mathbf{T} \mathbf{D} + \mathbf{T} \mathbf{W}) = \operatorname{tr}(\mathbf{T} \mathbf{D}) + \operatorname{tr}(\mathbf{T} \mathbf{W}). \quad (7.10.8)$$

But $\text{tr}(\mathbf{T}\mathbf{W}) = T_{ij}W_{ji} = T_{ji}W_{ji} = T_{ij}W_{ij} = -T_{ij}W_{ji} = 0$; therefore, we rediscover the energy equation in the following form [see Eq. (4.15.4)]:

$$\rho \frac{Du}{Dt} = \text{tr}(\mathbf{T}\mathbf{D}) - \text{div } \mathbf{q} + \rho q_s. \quad (7.10.9)$$

On the other hand, if we use the Reynolds equation in the form of Eq. (7.4.1), we obtain from Eq. (7.10.1)

$$\begin{aligned} \int_{S_c} \mathbf{t} \cdot \mathbf{v} dS + \int_{V_c} \rho \mathbf{B} \cdot \mathbf{v} dV - \int_{S_c} \mathbf{q} \cdot \mathbf{n} dS + \int_{V_c} \rho q_s dV = \\ \int_{V_c} \rho \frac{\partial}{\partial t} \left(\frac{v^2}{2} + u \right) dV + \int_{S_c} \rho \left(\frac{v^2}{2} + u \right) (\mathbf{v} \cdot \mathbf{n}) dS. \end{aligned} \quad (7.10.10)$$

Equation (7.10.10) states that:

The time rate of work done by surface and body forces in a control volume + rate of heat input across the boundary surface + heat supply throughout the volume = total rate of increase of internal and kinetic energy of the material inside the control volume + rate of outflow of the internal and kinetic energy across the control surface.

Example 7.10.1

A supersonic one-dimensional flow in an insulating duct suffers a normal compression shock. Assuming ideal gas, find the pressure after the shock in terms of the pressure and velocity before the shock.

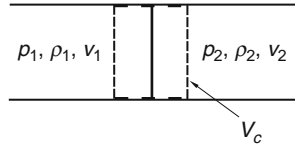

FIGURE 7.10-1

Solution

For the control volume shown in Figure 7.10-1, we have, for steady flow:

1. Mass outflux = mass influx, that is,

$$\rho_1 A v_1 = \rho_2 A v_2, \quad (i)$$

i.e.,

$$\rho_1 v_1 = \rho_2 v_2 \quad (ii)$$

2. Force in x direction = net momentum outflux in x direction,

$$\rho_1 A - \rho_2 A = (\rho_2 A v_2) v_2 - (\rho_1 A v_1) v_1. \quad (iii)$$

Using Eq. (ii), we have

$$p_1 - p_2 = \rho_2 v_2^2 - \rho_1 v_1^2 = \rho_1 v_1 (v_2 - v_1). \quad (\text{iv})$$

3. Rate of work done by surface forces = net energy (internal and kinetic) outflux. That is,

$$\rho_1 A v_1 - \rho_2 A v_2 = (\rho_2 A v_2) u_2 - (\rho_1 A v_1) u_1 + \left[\frac{1}{2} (\rho_2 A v_2) v_2^2 - \frac{1}{2} (\rho_1 A v_1) v_1^2 \right]. \quad (\text{v})$$

For ideal gas [see Eq. (6.26.8), Chapter 6],

$$u = \frac{p}{\rho} \left(\frac{1}{\gamma - 1} \right), \quad (\text{vi})$$

where $\gamma = c_p/c_v$ is the ratio of specific heats. Thus, Eq. (v) becomes

$$\rho_1 v_1 - \rho_2 v_2 = (\rho_2 v_2) \left(\frac{1}{\gamma - 1} \right) - (\rho_1 v_1) \left(\frac{1}{\gamma - 1} \right) + \left[\frac{1}{2} \rho_2 v_2^3 - \frac{1}{2} \rho_1 v_1^3 \right], \quad (\text{vii})$$

or

$$(\rho_1 v_1) \left(\frac{\gamma}{\gamma - 1} \right) + \frac{1}{2} \rho_1 v_1^3 = (\rho_2 v_2) \left(\frac{\gamma}{\gamma - 1} \right) + \frac{1}{2} \rho_2 v_2^3. \quad (\text{viii})$$

That is,

$$(\rho_1 v_1) \left(\frac{\gamma}{\gamma - 1} \frac{\rho_1}{\rho_1} + \frac{1}{2} v_1^2 \right) = (\rho_2 v_2) \left(\frac{\gamma}{\gamma - 1} \frac{\rho_2}{\rho_2} + \frac{1}{2} v_2^2 \right). \quad (\text{ix})$$

In view of Eq. (ii), this equation becomes

$$\frac{\gamma}{\gamma - 1} \frac{\rho_1}{\rho_1} + \frac{1}{2} v_1^2 = \frac{\gamma}{\gamma - 1} \frac{\rho_2}{\rho_2} + \frac{1}{2} v_2^2. \quad (\text{x})$$

From Eqs. (ii), (iv), and (x), one can obtain the following quadratic equation for p_2/p_1 in terms of the Mach number $M_1 = (v_1/a)$, $a^2 = \gamma p_1/\rho_1$ (see Prob.7.27):

$$\left(\frac{p_2}{p_1} \right)^2 - \frac{2}{(\gamma + 1)} \frac{p_2}{p_1} (\gamma M_1^2 + 1) - \frac{2}{(\gamma + 1)} \left(\frac{\gamma - 1}{2} - \gamma M_1^2 \right) = 0. \quad (\text{xi})$$

This equation has two roots:

$$p_2 = p_1, \quad (\text{xii})$$

and

$$p_2 = \frac{1}{\gamma + 1} [2\gamma M_1^2 - (\gamma - 1)] p_1 \quad \text{or} \quad p_2 = \frac{1}{\gamma + 1} [2\rho_1 v_1^2 - (\gamma - 1)\rho_1]. \quad (\text{xiii})$$

The second root describes the pressure after the shock in terms of the pressure and velocity before the shock.

7.11 THE ENTROPY INEQUALITY: THE SECOND LAW OF THERMODYNAMICS

The entropy inequality, also known as the Clausius-Duhem inequality or the second law of thermodynamics, is given by the following inequality:

$$\frac{D}{Dt} \int_{V_m} \rho \eta dV \geq - \int_{S_c} \frac{\mathbf{q}}{\Theta} \cdot \mathbf{n} dS + \int_{V_c} \frac{\rho q_s}{\Theta} dV, \quad (7.11.1)$$

where η is the entropy per unit mass; V_m the material volume; S_c and V_c the control surface and the control volume, respectively, which are instantaneously coincidental with the surface and the volume of the material; \mathbf{q} is the heat flux vector; Θ is the absolute temperature; \mathbf{n} is the unit outward vector [thus, $(-\mathbf{q} \cdot \mathbf{n})$ is heat flux *into* the volume across the surface S_c]; and q_s is the heat supply per unit mass, if any, within the control volume.

The inequality states that:

The rate of increase of entropy in a fixed part of material is not less than the influx of entropy, \mathbf{q}/Θ , across the surface of the part + the entropy supply within the volume.

Now

$$\frac{D}{Dt} \int_{V_m} \rho \eta dV = \int_{V_m} \left[\frac{D}{Dt} (\rho \eta dV) \right] = \int_{V_m} \left[\eta \frac{D}{Dt} (\rho dV) + \frac{D\eta}{Dt} \rho dV \right] = \int_{V_c} \rho \frac{D\eta}{Dt} dV, \quad (7.11.2)$$

where we have used the conservation of mass equation in the form

$$\frac{D}{Dt} (\rho dV) = 0. \quad (7.11.3)$$

Thus, using Eqs. (7.11.2) and (7.2.5), Eq. (7.11.1) can be written:

$$\int_{V_c} \rho \frac{D\eta}{Dt} dV \geq - \int_{V_c} \operatorname{div} \left(\frac{\mathbf{q}}{\Theta} \right) dV + \int_{V_c} \frac{\rho q_s}{\Theta} dV. \quad (7.11.4)$$

In differential form, we have the following second law of thermodynamics:

$$\rho \frac{D\eta}{Dt} \geq - \operatorname{div} \left(\frac{\mathbf{q}}{\Theta} \right) + \frac{\rho q_s}{\Theta} \quad (7.11.5)$$

This is the same entropy equation given in Section 4.16 (Eq. 4.16.2).

We now show that Eq. (7.11.4) can also be written in the following form for material within a fixed control volume:

$$\frac{\partial}{\partial t} \int_{V_c} \rho \eta dV \geq - \int_{S_c} \eta \rho \mathbf{v} \cdot \mathbf{n} dS - \int_{S_c} \frac{\mathbf{q}}{\Theta} \cdot \mathbf{n} dS + \int_{V_c} \frac{\rho q_s}{\Theta} dV. \quad (7.11.6)$$

To do that, since $D\rho/Dt = -\rho \operatorname{div} \mathbf{v}$ (conservation of mass equation), we have

$$\begin{aligned} \rho \frac{D\eta}{Dt} &= \frac{D(\rho\eta)}{Dt} - \eta \frac{D\rho}{Dt} = \frac{D(\rho\eta)}{Dt} + \eta\rho \operatorname{div} \mathbf{v} = \frac{D(\rho\eta)}{Dt} + \operatorname{div}(\eta\rho\mathbf{v}) - \mathbf{v} \cdot \nabla(\eta\rho) \\ &= \frac{\partial(\rho\eta)}{\partial t} + \operatorname{div}(\eta\rho\mathbf{v}). \end{aligned} \quad (7.11.7)$$

Thus, in view of Eq. (7.11.2), we have

$$\frac{D}{Dt} \int_{V_m} \rho\eta dV = \int_{V_c} \rho \frac{D\eta}{Dt} dV = \int_{V_c} \frac{\partial(\rho\eta)}{\partial t} dV + \int_{V_c} \operatorname{div}(\eta\rho\mathbf{v}) dV. \quad (7.11.8)$$

Using the divergence theorem for the last integral in the preceding equation, we have

$$\frac{D}{Dt} \int_{V_m} \rho\eta dV = \int_{V_c} \frac{\partial(\rho\eta)}{\partial t} dV + \int_{S_c} \eta\rho\mathbf{v} \cdot \mathbf{n} dV. \quad (7.11.9)$$

We now have the alternate form of the entropy inequality:

$$\int_{V_c} \frac{\partial(\rho\eta)}{\partial t} dV \geq - \int_{S_c} \eta\rho\mathbf{v} \cdot \mathbf{n} dS - \int_{S_c} \frac{\mathbf{q}}{\Theta} \cdot \mathbf{n} dS + \int_{V_c} \frac{\rho q_s}{\Theta} dV, \quad (7.11.10)$$

or

$$\frac{\partial}{\partial t} \int_{V_c} \rho\eta dV \geq - \int_{S_c} \eta\rho\mathbf{v} \cdot \mathbf{n} dS - \int_{S_c} \frac{\mathbf{q}}{\Theta} \cdot \mathbf{n} dS + \int_{V_c} \frac{\rho q_s}{\Theta} dV. \quad (7.11.11)$$

The preceding inequality states that:

The rate of increase of entropy for the material within the fixed control volume V_c is not less than the entropy entering the volume due to convection of material and conduction of heat through the control surface S_c + entropy supply within the volume.

Example 7.11.1

From the second law of thermodynamics, demonstrate that heat flow through conduction is always in the direction from high temperature to low temperature.

Solution

Consider a cylinder of fixed continuum insulated on its lateral surface and that undergoes steady heat conduction in the direction from the left end face at temperature Θ_1 to the right end face at temperature Θ_2 .

Let the cross-sectional area of the cylinder be A and the one-dimensional heat flux from left to right be q . With $\partial()/\partial t = 0$, $\mathbf{v} = 0$, and $q_s = 0$, the inequality (7.11.11) states that

$$0 \geq \frac{q}{\Theta_1} A - \frac{q}{\Theta_2} A = qA \left(\frac{1}{\Theta_1} - \frac{1}{\Theta_2} \right).$$

Thus, $\left(\frac{1}{\Theta_1} - \frac{1}{\Theta_2} \right) \leq 0$, or $\Theta_2 - \Theta_1 \leq 0$. In other words, Θ_1 is not less than Θ_2 .

PROBLEMS FOR CHAPTER 7

7.1 Verify the divergence theorem $\int_S \mathbf{v} \cdot \mathbf{n} dS = \int_V \text{div } \mathbf{v} dV$ for the vector field $\mathbf{v} = 2x\mathbf{e}_1 + z\mathbf{e}_2$ by considering the region bounded by

$$x = 0, \quad x = 2, \quad y = 0, \quad y = 2, \quad z = 0, \quad z = 2.$$

7.2 Verify the divergence theorem $\int_S \mathbf{v} \cdot \mathbf{n} dS = \int_V \text{div } \mathbf{v} dV$ for the vector field, which, in cylindrical coordinates, is $\mathbf{v} = 2r\mathbf{e}_r + z\mathbf{e}_z$, by considering the region bounded by $r = 2$, $z = 0$, and $z = 4$.

7.3 Verify the divergence theorem $\int_S \mathbf{v} \cdot \mathbf{n} dS = \int_V \text{div } \mathbf{v} dV$ for the vector field, which, in spherical coordinates, is $\mathbf{v} = 2r\mathbf{e}_r$, by considering the region bounded by the spherical surface $r = 2$.

7.4 Show that $\int_S \mathbf{x} \cdot \mathbf{n} dS = 3V$, where \mathbf{x} is the position vector and V is the volume enclosed by the boundary surface S .

7.5 (a) Consider the vector field $\mathbf{v} = \varphi\mathbf{a}$, where φ is a given scalar field and \mathbf{a} is an arbitrary constant vector (independent of position). Using the divergence theorem, prove that $\int_V \nabla \varphi dV = \int_S \varphi \mathbf{n} dS$. (b) Show that for any closed surface S , $\int_S \mathbf{n} dS = \mathbf{0}$ where \mathbf{n} is normal to the surface.

7.6 A stress field \mathbf{T} is in equilibrium with a body force $\rho\mathbf{B}$. Using the divergence theorem, show that for any volume V with boundary surface S

$$\int_S \mathbf{t} dS + \int_V \rho\mathbf{B} dV = \mathbf{0},$$

where \mathbf{t} is the stress vector. That is, the total resultant force is equipollent to zero.

7.7 Let \mathbf{u}^* define an infinitesimal strain field $\mathbf{E}^* = \frac{1}{2} [\nabla \mathbf{u}^* + (\nabla \mathbf{u}^*)^T]$ and let \mathbf{T}^{**} be the symmetric stress tensor in static equilibrium with a body force $\rho\mathbf{B}^{**}$ and a surface traction \mathbf{t}^{**} . Using the divergence theorem, verify the following identity (theory of virtual work):

$$\int_S \mathbf{t}^{**} \cdot \mathbf{u}^* dS + \int_V \rho\mathbf{B}^{**} \cdot \mathbf{u}^* dV = \int_V T_{ij}^{**} E_{ij}^* dV.$$

7.8 Using the equations of motion and the divergence theorem, verify the following rate of work identity. Assume the stress tensor to be symmetric.

$$\int_S \mathbf{t} \cdot \mathbf{v} dS + \int_V \rho\mathbf{B} \cdot \mathbf{v} dV = \int_V \rho \frac{D}{Dt} \left(\frac{v^2}{2} \right) dV + \int_V T_{ij} D_{ij} dV.$$

7.9 Consider the velocity and density fields

$$\mathbf{v} = \alpha x_1 \mathbf{e}_1, \quad \rho = \rho_0 e^{-\alpha(t-t_0)}.$$

(a) Check the equation of mass conservation. (b) Compute the mass and rate of increase of mass in the cylindrical control volume of cross-section A and bounded by $x_1 = 0$ and $x_1 = 3$. (c) Compute the net mass inflow into the control volume of part (b). Does the net mass inflow equal the rate of mass increase inside the control volume?

7.10 (a) Check that the following motion:

$$x_1 = X_1 e^{\alpha(t-t_0)}, \quad x_2 = X_2, \quad x_3 = X_3,$$

corresponds to the velocity field $\mathbf{v} = \alpha x_1 \mathbf{e}_1$. (b) For a density field $\rho = \rho_0 e^{-\alpha(t-t_0)}$, verify that the mass contained in the material volume that was coincident with the control volume described in (b) of Problem 7.9, at time t_0 , remains a constant at all times, as it should (conservation of mass). (c) Compute the total linear momentum for the material volume of part (b). (d) Compute the force acting on the material volume.

7.11 Do Problem 7.9 for the velocity field $\mathbf{v} = \alpha x_1 \mathbf{e}_1$ and the density field $\rho = k(\rho_0/x_1)$ and for the cylindrical control volume bounded by $x_1 = 1$ and $x_1 = 3$.

7.12 The center of mass $\mathbf{x}_{c.m}$ of a material volume is defined by the equation

$$m\mathbf{x}_{c.m} = \int_{V_m} \mathbf{x}\rho dV \quad \text{where} \quad m = \int_{V_m} \rho dV.$$

Demonstrate that the linear momentum principle may be written in the form

$$\int_S \mathbf{t}dS + \int_V \rho \mathbf{B}dV = m\mathbf{a}_{c.m},$$

where $\mathbf{a}_{c.m}$ is the acceleration of the mass center.

7.13 Consider the following velocity field and density field:

$$\mathbf{v} = \frac{\alpha x_1}{1 + \alpha t} \mathbf{e}_1, \quad \rho = \frac{\rho_0}{1 + \alpha t}.$$

(a) Compute the total linear momentum and rate of increase of linear momentum in a cylindrical control volume of cross-sectional area A and bounded by the planes $x_1 = 1$ and $x_1 = 3$. (b) Compute the net rate of outflow of linear momentum from the control volume of (a). (c) Compute the total force on the material in the control volume. (d) Compute the total kinetic energy and rate of increase of kinetic energy for the control volume of part (a). (e) Compute the net rate of outflow of kinetic energy from the control volume.

7.14 Consider the velocity and density fields: $\mathbf{v} = \alpha x_1 \mathbf{e}_1$, $\rho = \rho_0 e^{-\alpha(t-t_0)}$. For an arbitrary time t , consider the material contained in the cylindrical control volume of cross-sectional area A bounded by $x_1 = 0$ and $x_1 = 3$. (a) Determine the linear momentum and rate of increase of linear momentum in this control volume. (b) Determine the outflux of linear momentum. (c) Determine the net resultant force that is acting on the material contained in the control volume.

7.15 Do Problem 7.14 for the same velocity field, $\mathbf{v} = \alpha x_1 \mathbf{e}_1$, but with $\rho = k\rho_0/x_1$ and the cylindrical control volume bounded by $x_1 = 1$ and $x_1 = 3$.

7.16 Consider the flow field $\mathbf{v} = k(x\mathbf{e}_1 - y\mathbf{e}_2)$ with $\rho = \text{constant}$. For a control volume defined by $x = 0, x = 2, y = 0, y = 2, z = 0, z = 2$, determine the net resultant force and moment about the origin that are acting on the material contained in this volume.

7.17 For Hagen-Poiseuille flow in a pipe: $\mathbf{v} = C(r_0^2 - r^2)\mathbf{e}_1$. Calculate the momentum flux across a cross-section. For the same flow rate, if the velocity is assumed to be uniform, what is the momentum flux across a cross-section? Compare the two results.

- 7.18 Consider a steady flow of an incompressible viscous fluid of density ρ , flowing up a vertical pipe of radius R . At the lower section of the pipe, the flow is uniform with a speed v_l and a pressure p_l . After flowing upward through a distance ℓ , the flow becomes fully developed with a parabolic velocity distribution at the upper section, where the pressure is p_u . Obtain an expression for the fluid pressure drop $p_l - p_u$ between the two sections in terms of ρ , R , and the frictional force F_f exerted on the fluid column from the wall through viscosity.
- 7.19 A pile of chain on a table falls through a hole in the table under the action of gravity. Derive the differential equation governing the hanging length x . Assume that the pile is large compared with the hanging portion.
- 7.20 A water jet of 5 cm diameter moves at 12 m/sec, impinging on a curved vane that deflects it 60° from its original direction. Neglecting the weight, obtain the force exerted by the liquid on the vane (see Figure 7.6-2).
- 7.21 A horizontal pipeline of 10 cm diameter bends through 90° , and while bending, changes its diameter to 5 cm. The pressure in the 10 cm pipe is 140 kPa. Estimate the resultant force on the bends when $0.005 \text{ m}^3/\text{sec}$ of water is flowing in the pipeline.
- 7.22 Figure P7.1 shows a steady water jet of area A impinging onto a flat wall. Find the force exerted on the wall. Neglect weight and viscosity of water.

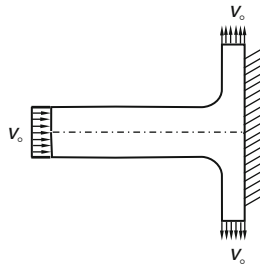

FIGURE P7.1

- 7.23 Frequently in open channel flow, a high-speed flow “jumps” to a low-speed flow with an abrupt rise in the water surface. This is known as a *hydraulic jump*. Referring to Figure P7.2, if the flow rate is Q per unit width, show that when the jump occurs, the relation between y_1 and y_2 is given by $y_2 = -y_1/2 + (y_1/2)\sqrt{1 + (8v_1^2/gy_1)}$. Assume that the flow before and after the jump is uniform and the pressure distribution is hydrostatic.

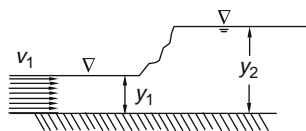
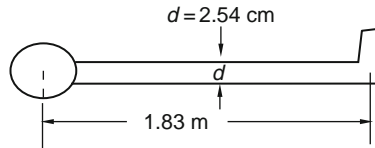
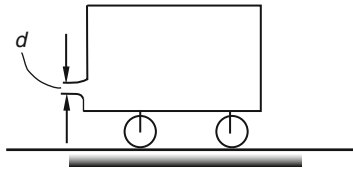

FIGURE P7.2

- 7.24** If the curved vane of Example 7.6.2 moves with a velocity $v < v_o$ in the same direction as the oncoming jet, find the resultant force exerted on the vane by the jet.
- 7.25** For the half-arm sprinkler shown in Figure P7.3, find the angular speed if $Q = 0.566 \text{ m}^3/\text{sec}$. Neglect friction.

**FIGURE P7.3**

- 7.26** The tank car shown in Figure P7.4 contains water and compressed air regulated to force a water jet out of the nozzle at a constant rate of $Q \text{ m}^3/\text{sec}$. The diameter of the jet is $d \text{ cm}$, and the initial total mass of the tank car is M_o . Neglecting frictional forces, find the velocity of the car as a function of time.

**FIGURE P7.4**

- 7.27** For the one-dimensional problem discussed in Section 7.10, (a) from the continuity equation $\rho_1 v_1 = \rho_2 v_2$ and the momentum equation $p_1 - p_2 = \rho_2 v_2^2 - \rho_1 v_1^2$, obtain

$$\frac{v_2}{v_1} = 1 - \frac{1}{\gamma M_1^2} \left(\frac{p_2}{p_1} - 1 \right).$$

- (b) From the energy equation $\frac{\gamma}{\gamma - 1} \frac{p_1}{\rho_1} + \frac{1}{2} v_1^2 = \frac{\gamma}{\gamma - 1} \frac{p_2}{\rho_2} + \frac{1}{2} v_2^2$, obtain

$$1 + \frac{\gamma - 1}{2} \frac{v_1^2}{a_1^2} = \frac{p_2}{p_1} \left(\frac{v_2}{v_1} \right) + \frac{\gamma - 1}{2} \frac{v_1^2}{a_1^2} \left(\frac{v_2}{v_1} \right)^2.$$

- (c) From the results of (a) and (b), obtain

$$\left(\frac{p_2}{p_1} \right)^2 - \frac{2}{\gamma + 1} (1 + \gamma M_1^2) \left(\frac{p_2}{p_1} \right) - \frac{2}{\gamma + 1} \left(\frac{\gamma - 1}{2} - \gamma M_1^2 \right) = 0.$$

This page intentionally left blank

Non-Newtonian Fluids

In Chapter 6, the linear viscous fluid was discussed as an example of a constitutive equation of an idealized fluid. The mechanical behaviors of many real fluids are adequately described under a wide range of circumstances by this constitutive equation, which is referred to as the *constitutive equation of Newtonian fluids*. Many other real fluids exhibit behaviors that are not accounted for by the theory of Newtonian fluids. Examples of such substances include polymeric solutions, paints, and molasses.

For a steady unidirectional laminar flow of water in a circular pipe, the theory of Newtonian fluids gives the experimentally confirmed result that the volume discharge Q is proportional to the (constant) pressure gradient $|dp/dz|$ in the axial direction and to the fourth power of the diameter d of the pipe, that is [see Eq. (6.13.12)],

$$Q = \frac{\pi d^4}{128\mu} \left| \frac{dp}{dz} \right|. \quad (8.0.1)$$

However, for many polymeric solutions, it has been observed that the preceding equation does not hold. For a fixed d , the Q vs. $|dp/dz|$ relation is nonlinear as sketched in the Figure 8.0-1.

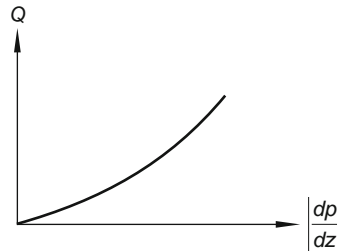

FIGURE 8.0-1

For a steady laminar flow of water placed between two very long coaxial cylinders of radii r_1 and r_2 , if the inner cylinder is at rest while the outer one is rotating with an angular velocity Ω , the theory of Newtonian fluid gives the result, agreeing with experimental observations, that the torque per unit length that must be applied to the cylinders to maintain the flow is proportional to Ω . In fact [see Eq. (6.15.9)],

$$M = \frac{4\pi\mu r_1^2 r_2^2 \Omega}{r_2^2 - r_1^2}. \quad (8.0.2)$$

However, for those fluids that do not obey Eq. (8.0.1), it is found that they do not obey Eq. (8.0.2) either. Furthermore, for Newtonian fluids such as water in this flow, the normal stress exerted on the outer cylinder is always larger than that on the inner cylinder due to the effect of centrifugal forces. However, for those fluids that do not obey Eq. (8.0.1), the compressive normal stress on the inner cylinder can be larger than that on the outer cylinder. Figure 8.0-2 is a schematic diagram showing a higher fluid level in the center tube than in the outer tube for a non-Newtonian fluid in spite of the centrifugal forces due to the rotations of the cylinders. Other manifestations of the non-Newtonian behaviors include the ability of the fluids to store elastic energy and the occurrence of nonzero stress relaxation time.

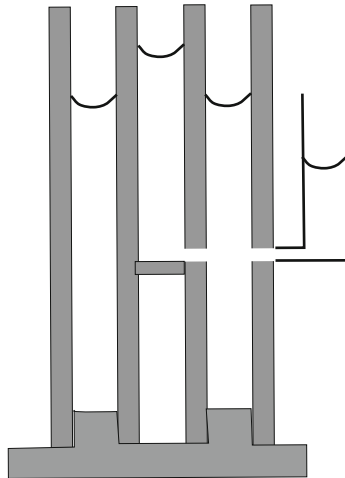

FIGURE 8.0-2

In this chapter we discuss several constitutive equations that define idealized viscoelastic fluids exhibiting various characteristics of non-Newtonian behaviors.

PART A: LINEAR VISCOELASTIC FLUID

8.1 LINEAR MAXWELL FLUID

The *linear Maxwell fluid* is defined by the following constitutive equations:

$$\mathbf{T} = -p\mathbf{I} + \mathbf{S}, \quad (8.1.1)$$

$$\mathbf{S} + \lambda \frac{\partial \mathbf{S}}{\partial t} = 2\mu \mathbf{D}, \quad (8.1.2)$$

where $-p\mathbf{I}$ is the isotropic pressure that is constitutively indeterminate due to the incompressibility property of the fluid; \mathbf{S} is called the *extra stress*, which is related to the rate of deformation \mathbf{D} by Eq. (8.1.2); and λ and μ are material coefficients.

In the following example, we show, with the help of a mechanical analogy, that the linear Maxwell fluid possesses elasticity.

Example 8.1.1

Figure 8.1-1 shows the so-called linear Maxwell element, which consists of a spring (an elastic element) with spring constant G , connected in series to a viscous dashpot (viscous element) with a damping coefficient η . The elongation ε of the Maxwell element can be divided into an elastic portion ε_e and a viscous portion ε_η , i.e.,

$$\varepsilon = \varepsilon_e + \varepsilon_\eta. \quad (8.1.3)$$

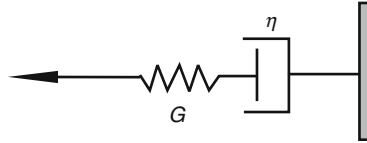
**FIGURE 8.1-1**

Since the spring and the dashpot are connected in series, the force S in each is the same for all time. That is,

$$S = G\varepsilon_e = \eta \frac{d\varepsilon_\eta}{dt}. \quad (8.1.4)$$

Thus,

$$\frac{d\varepsilon_e}{dt} = \frac{1}{G} \frac{dS}{dt} \quad \text{and} \quad \frac{d\varepsilon_\eta}{dt} = \frac{S}{\eta}. \quad (8.1.5)$$

Taking the time derivative of Eq. (8.1.3) and using the equations in Eq. (8.1.5), we have

$$S + \lambda \frac{dS}{dt} = \eta \frac{d\varepsilon}{dt}, \quad (8.1.6)$$

where

$$\lambda = \frac{\eta}{G}. \quad (8.1.7)$$

We note that λ has the dimension of time, the physical meaning of which is discussed shortly. Equation (8.1.6) is of the same form as Eq. (8.1.2). Indeed, both \mathbf{D} and $d\varepsilon/dt$ (in the right-hand side of these equations) describe rates of deformation. Thus, by analogy, we see that the constitutive equation, Eq. (8.1.2), endows the fluid with “elasticity” through the term $\lambda(\partial\mathbf{S}/\partial t)$.

Let us consider the following experiment performed on the Maxwell element: Starting at time $t = 0$, a constant force S_0 is applied to the element. We are interested in how, for $t > 0$, the strain changes with time. This is the so-called *creep experiment*. From Eq. (8.1.6), we have, since S is a constant for $t > 0$, $dS/dt = 0$ for $t > 0$ so that

$$\frac{d\varepsilon}{dt} = \frac{S_0}{\eta} \quad \text{for } t > 0, \quad (8.1.8)$$

which yields

$$\varepsilon = \frac{S_0}{\eta} t + \varepsilon_0. \quad (8.1.9)$$

The integration constant ε_0 is the instantaneous strain ε of the element at $t = 0^+$ from the elastic response of the spring and is therefore given by S_0/G . Thus,

$$\varepsilon = \frac{S_0}{\eta}t + \frac{S_0}{G}. \quad (8.1.10)$$

We see from Eq. (8.1.10) that under the action of a constant force S_0 in a creep experiment, the strain of the Maxwell element first has an instantaneous jump from 0 to S_0/G and then continues to increase with time (i.e., flows) without limit, with a rate of flow inversely proportional to the viscosity.

We note that there are no contributions to the instantaneous strain from the dashpot because, with $d\varepsilon/dt \rightarrow \infty$, an infinitely large force is required for the dashpot to do that. On the other hand, there are no contributions to the rate of elongation from the spring because the elastic response is a constant under a constant load.

We may write Eq. (8.1.10) as

$$\frac{\varepsilon}{S_0} = \frac{1}{\eta}t + \frac{1}{G} \equiv J(t). \quad (8.1.11)$$

The function $J(t)$ gives the creep history per unit force. It is known as the *creep compliance function* of the linear Maxwell element.

In another experiment, the Maxwell element is given a strain ε_0 at $t = 0$, which is then maintained for all time. We are interested in how the force S changes with time. This is the so-called *stress relaxation experiment*. From Eq. (8.1.6), with $d\varepsilon/dt = 0$ for $t > 0$, we have

$$S + \lambda \frac{dS}{dt} = 0 \quad \text{for } t > 0, \quad (8.1.12)$$

which yields

$$S = S_0 e^{-t/\lambda}. \quad (8.1.13)$$

The integration constant S_0 is the instantaneous force that is required to produce the elastic strain ε_0 at $t = 0^+$. That is, $S_0 = G\varepsilon_0$. Thus,

$$S = G\varepsilon_0 e^{-t/\lambda}. \quad (8.1.14)$$

Equation (8.1.14) is the force history for the stress relaxation experiment for the Maxwell element. We may write Eq. (8.1.14) as

$$\frac{S}{\varepsilon_0} = G e^{-t/\lambda} = \frac{\eta}{\lambda} e^{-t/\lambda} \equiv \phi(t). \quad (8.1.15)$$

The function $\phi(t)$ gives the stress history per unit strain. It is called the *stress relaxation function*, and the constant λ is known as the *relaxation time*, which is the time for the force to relax to $1/e$ of the initial value of S .

It is interesting to consider the limiting cases of the Maxwell element. If $G \rightarrow \infty$, then the spring element becomes a rigid bar, and the element no longer possesses elasticity. That is, it is a purely viscous element. In the creep experiment, there will be no instantaneous elongation; the element simply creeps linearly with time [see Eq. (8.1.10)] from the unstretched initial position. In the stress relaxation experiment, an infinitely large force is needed at $t = 0$ to produce the finite jump in elongation ε_0 . The force is, however, instantaneously returned to zero (i.e., the relaxation time $\lambda = \eta/G \rightarrow 0$). We can write the relaxation function for the purely viscous element in the following way:

$$\phi(t) = \eta \delta(t), \quad (8.1.16)$$

where $\delta(t)$ is known as the *Dirac delta function*, which may be defined as the derivative of the unit step function $H(t)$, defined by

$$H(t) = \begin{cases} 0 & -\infty < t < 0 \\ 1 & 0 \leq t < \infty, \end{cases} \quad (8.1.17)$$

so that

$$\delta(t) = \frac{dH(t)}{dt}, \quad (8.1.18)$$

and

$$\int^t \delta(t) dt = H(t). \quad (8.1.19)$$

Example 8.1.2

Consider a linear Maxwell fluid, defined by Eqs. (8.1.1) and (8.1.2), in steady simple shearing flow: $v_1 = kx_2$, $v_2 = v_3 = 0$. Find the stress components.

Solution

Since the given velocity field is steady, all field variables are independent of time. Thus, $(\partial/\partial t)\mathbf{S} = 0$ and we have

$$\mathbf{S} = 2\mu\mathbf{D}.$$

Thus, the stress field is exactly the same as that of a Newtonian incompressible fluid.

Example 8.1.3

For a Maxwell fluid, consider the stress relaxation experiment with the displacement field given by

$$u_1 = \varepsilon_0 H(t)x_2, \quad u_2 = u_3 = 0, \quad (i)$$

where $H(t)$ is the unit step function defined in Eq. (8.1.17). Neglecting inertia effects, (a) obtain the components of the rate of deformation tensor, (b) obtain S_{12} at $t = 0$, and (c) obtain the history of the shear stress S_{12} .

Solution

(a) Differentiating Eq. (i) with respect to time, we get

$$v_1 = \varepsilon_0 \delta(t)x_2, \quad v_2 = v_3 = 0, \quad (ii)$$

where $\delta(t)$ is the Dirac delta function defined in Eq. (8.1.18). The only nonzero rate of deformation is

$$D_{12} = \frac{1}{2} \left(\frac{\partial v_1}{\partial x_2} + \frac{\partial v_2}{\partial x_1} \right) = \frac{\varepsilon_0 \delta(t)}{2}.$$

(b) From Eq. (8.1.2), we obtain

$$S_{12} + \lambda \frac{\partial S_{12}}{\partial t} = \mu \varepsilon_0 \delta(t). \quad (iii)$$

Integrating the preceding equation from $t = 0 - e$ to $t = 0 + e$, we have

$$\int_{0-e}^{0+e} S_{12} dt + \lambda \int_{0-e}^{0+e} \frac{\partial S_{12}}{\partial t} dt = \mu \varepsilon_0 \int_{0-e}^{0+e} \delta(t) dt. \quad (\text{iv})$$

The integral on the right-hand side of the preceding equation is equal to unity [see Eq. (8.1.19)]. As $e \rightarrow 0$, the first integral on the left side approaches zero, whereas the second integral becomes

$$[S_{12}(0^+) - S_{12}(0^-)].$$

Since $S_{12}(0^-) = 0$, Eq. (iv) gives

$$S_{12}(0^+) = \frac{\mu \varepsilon_0}{\lambda}. \quad (\text{v})$$

For $t > 0$, $\delta(t) = 0$ so that Eq. (iii) becomes

$$S_{12} + \lambda \frac{\partial S_{12}}{\partial t} = 0, \quad t > 0. \quad (\text{vi})$$

The solution of the preceding equation with the initial condition $S_{12}(0^+) = \frac{\mu \varepsilon_0}{\lambda}$ is

$$\frac{S_{12}}{\varepsilon_0} = \frac{\mu}{\lambda} e^{-t/\lambda}. \quad (8.1.20)$$

This is the same relaxation function we obtained for the spring-dashpot model in Eq. (8.1.15). In arriving at Eq. (8.1.15), we made use of the initial condition $S_0 = G\varepsilon_0$, which was obtained from considerations of the responses of the elastic element. Here, in the present example, the initial condition is obtained by integrating the differential equation, Eq. (iii), over an infinitesimal time interval (from $t = 0^-$ to $t = 0^+$). By comparing Eq. (8.1.20) with Eq. (8.1.15) of the mechanical model, we see that μ/λ is the equivalent of the spring constant G of the mechanical model. It gives a measure of the elasticity of the linear Maxwell fluid.

Example 8.1.4

A linear Maxwell fluid is confined between two infinitely large parallel plates. The bottom plate is fixed. The top plate undergoes a one-dimensional oscillation of small amplitude u_0 in its own plane. Neglecting inertia effects, find the response of the shear stress.

Solution

The boundary conditions for the displacement components may be written:

$$y = h: \quad u_x = u_0 e^{i\omega t}, \quad u_y = u_z = 0, \quad (\text{i})$$

$$y = 0: \quad u_x = u_y = u_z = 0, \quad (\text{ii})$$

where $i = \sqrt{-1}$ and $e^{i\omega t} = \cos \omega t + i \sin \omega t$. We may take the real part of u_x to correspond to our physical problem. That is, in the physical problem, $u_x = u_0 \cos \omega t$.

Consider the following displacement field:

$$u_x(y) = u_0 e^{i\omega t} (y/h), \quad u_y = u_z = 0. \quad (\text{iii})$$

Clearly, this displacement field satisfies the boundary conditions (i) and (ii). The velocity field corresponding to Eq. (iii) is

$$v_x(y) = i\omega u_0 e^{i\omega t} (y/h), \quad v_y = v_z = 0. \quad (\text{iv})$$

Thus, the components of the rate of deformation tensor \mathbf{D} are

$$D_{12} = \frac{1}{2} i\omega u_0 e^{i\omega t} (1/h), \quad \text{all other } D_{ij} = 0. \quad (\text{v})$$

This is a homogeneous field, and it corresponds to a homogeneous stress field. In the absence of inertia forces, every homogeneous stress field satisfies all the momentum equations and is therefore a physically acceptable solution. Let the homogeneous stress component S_{12} be given by

$$S_{12} = S_0 e^{i\omega t}. \quad (\text{vi})$$

Then the equation $S_{12} + \lambda \frac{\partial S_{12}}{\partial t} = 2\mu D_{12}$ gives $(1 + \lambda i\omega)S_0 = \mu i\omega \frac{u_0}{h}$. That is,

$$\frac{S_0}{(u_0/h)} = \frac{\mu i\omega}{(1 + i\lambda\omega)} = \frac{\mu i\omega(1 - i\lambda\omega)}{(1 + i\lambda\omega)(1 - i\lambda\omega)} = \frac{\mu\lambda\omega^2}{1 + \lambda^2\omega^2} + i \frac{\mu\omega}{1 + \lambda^2\omega^2}. \quad (\text{vii})$$

Let

$$G^* = \frac{S_0}{(u_0/h)}, \quad (8.1.21)$$

then

$$S_{12} = G^*(u_0/h)e^{i\omega t}. \quad (8.1.22)$$

The complex variable G^* is known as the *complex shear modulus*, which may be written

$$G^* = G'(\omega) + iG''(\omega), \quad (8.1.23)$$

where the real part of the complex modulus is

$$G'(\omega) = \frac{\mu\lambda\omega^2}{1 + \lambda^2\omega^2}, \quad (8.1.24)$$

and the imaginary part is

$$G''(\omega) = \frac{\mu\omega}{1 + \lambda^2\omega^2}. \quad (8.1.25)$$

If we write (μ/λ) as G , the spring constant in the spring-dashpot model, we have

$$G'(\omega) = \frac{\mu^2\omega^2 G}{G^2 + \mu^2\omega^2} \quad \text{and} \quad G''(\omega) = \frac{\mu\omega G^2}{G^2 + \mu^2\omega^2}. \quad (8.1.26)$$

We note that as limiting cases of the Maxwell model, a purely elastic element has $\mu \rightarrow \infty$ so that $G' = G$ and $G'' = 0$, and a purely viscous element has $G \rightarrow \infty$ so that $G' = 0$ and $G'' = \mu\omega$. Thus, G' characterizes the extent of elasticity of the fluid that is capable of storing elastic energy, whereas G'' characterizes the extent of loss of energy due to viscous dissipation of the fluid. Thus, G' is called the *storage modulus* and G'' is called the *loss modulus*.

Writing

$$G^* = |G^*|e^{i\delta}, \quad \text{where } |G^*| = (G'^2 + G''^2)^{1/2} \quad \text{and} \quad \tan \delta = \frac{G''}{G'}, \quad (8.1.27)$$

we have $G^*e^{i\omega t} = |G^*|e^{i(\omega t + \delta)}$, so that taking the real part of Eq. (8.1.22), we obtain

$$S_{12} = (u_0/h)|G^*|\cos(\omega t + \delta). \quad (8.1.28)$$

Thus, for a Maxwell fluid, the shear stress response in a sinusoidal oscillatory experiment under the condition that the inertia effects are negligible is

$$S_{12} = \frac{u_0}{h}|G^*|\cos(\omega t + \delta) = \left(\frac{u_0}{h}\right) \frac{\mu\omega}{\sqrt{1 + \lambda^2\omega^2}} \cos(\omega t + \delta), \quad (8.1.29)$$

where

$$\tan \delta = 1/(\lambda\omega). \quad (8.1.30)$$

The angle δ is known as the *phase angle*. For a purely elastic material ($\lambda \rightarrow \infty$) in a sinusoidal oscillation, the stress and the strain are oscillating in the same phase ($\delta = 0$), whereas for a purely viscous fluid ($\lambda \rightarrow 0$), the stress is 90° ahead of the strain.

8.2 A GENERALIZED LINEAR MAXWELL FLUID WITH DISCRETE RELAXATION SPECTRA

A linear Maxwell fluid with N discrete relaxation spectra is defined by the following constitutive equation:

$$\mathbf{S} = \sum_1^N \mathbf{S}_n \quad \text{with} \quad \mathbf{S}_n + \lambda_n \frac{\partial \mathbf{S}_n}{\partial t} = 2\mu_n \mathbf{D}. \quad (8.2.1)$$

The mechanical analog for this constitutive equation may be represented by N Maxwell elements connected in parallel. The shear relaxation function is the sum of the N relaxation functions, each with a different relaxation time λ_n :

$$\phi(t) = \sum_1^N \frac{\mu_n}{\lambda_n} e^{-t/\lambda_n}. \quad (8.2.2)$$

It can be shown that Eq. (8.2.1) is equivalent to the following constitutive equation:

$$\mathbf{S} + \sum_1^N a_n \frac{\partial^n \mathbf{S}}{\partial t^n} = b_0 \mathbf{D} + \sum_1^{N-1} b_n \frac{\partial^n \mathbf{D}}{\partial t^n}. \quad (8.2.3)$$

We demonstrate this equivalence for the case $N = 2$ as follows: When $N = 2$,

$$\mathbf{S} = \mathbf{S}_1 + \mathbf{S}_2, \quad (8.2.4)$$

with

$$\mathbf{S}_1 + \lambda_1 \frac{\partial \mathbf{S}_1}{\partial t} = 2\mu_1 \mathbf{D} \quad \text{and} \quad \mathbf{S}_2 + \lambda_2 \frac{\partial \mathbf{S}_2}{\partial t} = 2\mu_2 \mathbf{D}. \quad (8.2.5)$$

Now

$$(\lambda_1 + \lambda_2) \frac{\partial \mathbf{S}}{\partial t} = \lambda_1 \frac{\partial \mathbf{S}_1}{\partial t} + \lambda_2 \frac{\partial \mathbf{S}_2}{\partial t} + \lambda_2 \frac{\partial \mathbf{S}_1}{\partial t} + \lambda_1 \frac{\partial \mathbf{S}_2}{\partial t} = 2(\mu_1 + \mu_2) \mathbf{D} - \mathbf{S} + \lambda_2 \frac{\partial \mathbf{S}_1}{\partial t} + \lambda_1 \frac{\partial \mathbf{S}_2}{\partial t}, \quad (\text{i})$$

and

$$\lambda_1 \lambda_2 \frac{\partial^2 \mathbf{S}}{\partial t^2} = \lambda_1 \lambda_2 \frac{\partial^2 \mathbf{S}_1}{\partial t^2} + \lambda_1 \lambda_2 \frac{\partial^2 \mathbf{S}_2}{\partial t^2} = 2(\lambda_2 \mu_1 + \lambda_1 \mu_2) \frac{\partial \mathbf{D}}{\partial t} - \lambda_2 \frac{\partial \mathbf{S}_1}{\partial t} - \lambda_1 \frac{\partial \mathbf{S}_2}{\partial t}. \quad (\text{ii})$$

Adding Eqs. (i) and (ii), we have

$$\mathbf{S} + (\lambda_1 + \lambda_2) \frac{\partial \mathbf{S}}{\partial t} + \lambda_1 \lambda_2 \frac{\partial^2 \mathbf{S}}{\partial t^2} = 2(\mu_1 + \mu_2) \mathbf{D} + 2(\lambda_2 \mu_1 + \lambda_1 \mu_2) \frac{\partial \mathbf{D}}{\partial t}. \quad (\text{iii})$$

Let

$$a_1 = (\lambda_1 + \lambda_2), \quad a_2 = \lambda_1 \lambda_2, \quad b_0 = 2(\mu_1 + \mu_2) \quad \text{and} \quad b_1 = 2(\lambda_2 \mu_1 + \lambda_1 \mu_2), \quad (8.2.6)$$

we have

$$\mathbf{S} + a_1 \frac{\partial \mathbf{S}}{\partial t} + a_2 \frac{\partial^2 \mathbf{S}}{\partial t^2} = b_0 \mathbf{D} + b_1 \frac{\partial \mathbf{D}}{\partial t}. \quad (8.2.7)$$

Similarly, for $N = 3$, one can obtain the following (see Problem 8.2):

$$\begin{aligned} a_1 &= (\lambda_1 + \lambda_2 + \lambda_3), & a_2 &= (\lambda_1 \lambda_2 + \lambda_2 \lambda_3 + \lambda_3 \lambda_1), & a_3 &= \lambda_1 \lambda_2 \lambda_3, & b_0 &= 2(\mu_1 + \mu_2 + \mu_3), \\ b_1 &= 2[\mu_1(\lambda_2 + \lambda_3) + \mu_2(\lambda_3 + \lambda_1) + \mu_3(\lambda_1 + \lambda_2)], & b_2 &= 2[\mu_1 \lambda_2 \lambda_3 + \mu_2 \lambda_3 \lambda_1 + \mu_3 \lambda_1 \lambda_2]. \end{aligned} \quad (8.2.8)$$

8.3 INTEGRAL FORM OF THE LINEAR MAXWELL FLUID AND OF THE GENERALIZED LINEAR MAXWELL FLUID WITH DISCRETE RELAXATION SPECTRA

Consider the following integral form of the constitutive equation:

$$\mathbf{S} = 2 \int_{-\infty}^t \phi(t-t') \mathbf{D}(t') dt', \quad (8.3.1)$$

where

$$\phi(t) = \frac{\mu}{\lambda} e^{-t/\lambda}, \quad (8.3.2)$$

is the relaxation function for the linear Maxwell fluid.

If we differentiate Eq. (8.3.1) with respect to time t , we obtain (*note: t appears in both the integrand and the integration limit; we need to use the Leibnitz rule of differentiation*)

$$\frac{\partial \mathbf{S}}{\partial t} = \frac{2\mu}{\lambda} \left[\int_{-\infty}^t \left(-\frac{1}{\lambda} \right) e^{-(t-t')/\lambda} \mathbf{D}(t') dt' + \mathbf{D}(t) \right] = \left(-\frac{1}{\lambda} \right) \mathbf{S} + \frac{2\mu}{\lambda} \mathbf{D},$$

that is,

$$\mathbf{S} + \lambda \frac{\partial \mathbf{S}}{\partial t} = 2\mu \mathbf{D}. \quad (8.3.3)$$

Thus, the integral form of the constitutive equation, Eq. (8.3.1), with relaxation function given by Eq. (8.3.2), is the same as the rate form constitutive equation, Eq. (8.1.2). Of course, Eq. (8.3.1) is nothing but the solution of the linear nonhomogeneous ordinary differential equation, Eq. (8.1.2) (see Problem 8.6).

It is not difficult to show that the constitutive equation for the generalized linear Maxwell equation with N discrete relaxation spectra, Eq. (8.2.1), is equivalent to the following integral form:

$$\mathbf{S} = 2 \int_{-\infty}^t \phi(t-t') \mathbf{D}(t') dt' \quad \text{with} \quad \phi(t) = \sum_1^N \frac{\mu_n}{\lambda_n} e^{-t/\lambda_n}. \quad (8.3.4)$$

8.4 A GENERALIZED LINEAR MAXWELL FLUID WITH A CONTINUOUS RELAXATION SPECTRUM

The linear Maxwell fluid with a continuous relaxation spectrum is defined by the constitutive equation:

$$\mathbf{S} = 2 \int_{-\infty}^t \phi(t-t') \mathbf{D}(t') dt' \quad \text{with} \quad \phi(t) = \int_0^{\infty} \frac{H(\lambda)}{\lambda} e^{-t/\lambda} d\lambda. \quad (8.4.1)$$

The function $H(\lambda)/\lambda$ is the relaxation spectrum. The relaxation function in Eq. (8.4.1) can also be written:

$$\phi(t) = \int_0^{\infty} H(\lambda) e^{-t/\lambda} d \ln \lambda. \quad (8.4.2)$$

As we shall see later, the linear Maxwell models considered so far are physically acceptable models only if the motion is such that the components of the relative deformation gradient (i.e., deformation gradient measured from the configuration at the current time t ; see Section 8.6) are small. When this is the case, the components of rate of deformation tensor \mathbf{D} are also small so that [see Eq. (5.2.15), Example 5.2.1]

$$\mathbf{D} \approx \frac{\partial \mathbf{E}}{\partial t}, \quad (8.4.3)$$

where \mathbf{E} is the infinitesimal strain measured with respect to the current configuration.

Substituting the preceding approximation of \mathbf{D} in Eq. (8.4.1) and integrating the right-hand side by parts, we obtain

$$\mathbf{S} = 2 \int_{-\infty}^t \phi(t-t') \frac{\partial \mathbf{E}}{\partial t'} dt' = 2[\phi(t-t') \mathbf{E}(t')]_{t'=-\infty}^{t'=t} - 2 \int_{-\infty}^t \mathbf{E}(t') \frac{\partial \phi(t-t')}{\partial t'} dt'.$$

The first term in the right-hand side is zero because $\phi(\infty) = 0$ for a fluid and $\mathbf{E}(t) = 0$ because the deformation is measured relative to the configuration at time t . Thus,

$$\mathbf{S} = -2 \int_{-\infty}^t \mathbf{E}(t') \frac{\partial \phi(t-t')}{\partial t'} dt'. \quad (8.4.4)$$

Or, letting $t-t' = s$, we can write the preceding equation as

$$\mathbf{S} = -2 \int_{s=\infty}^{s=0} \frac{d\phi(s)}{ds} \mathbf{E}(t-s) ds = 2 \int_{s=0}^{s=\infty} \frac{d\phi(s)}{ds} \mathbf{E}(t-s) ds. \quad (8.4.5)$$

Let

$$f(s) \equiv \frac{d\phi(s)}{ds}. \quad (8.4.6)$$

Eq. (8.4.5) then becomes

$$\mathbf{S} = 2 \int_{s=0}^{s=\infty} f(s) \mathbf{E}(t-s) ds. \quad (8.4.7)$$

Or

$$\mathbf{S} = 2 \int_{-\infty}^t f(t-t') \mathbf{E}(t') dt'. \quad (8.4.8)$$

Equation (8.4.7) or (8.4.8) is the integral form of the constitutive equation for the linear Maxwell fluid written in terms of the infinitesimal strain tensor \mathbf{E} (instead of the rate of deformation tensor \mathbf{D}). The function $f(s)$ in these equations is known as the *memory function*. The relation between the memory function and the relaxation function is given by Eq. (8.4.6).

The constitutive equation given by Eq. (8.4.7) or (8.4.8) can be viewed as the superposition of all the stresses, weighted by the memory function $f(s)$, caused by the deformation of the fluid particle (relative to the current time) at all past times ($t' = -\infty$ to the current time t).

For the linear Maxwell fluid with one relaxation time, the memory function is given by

$$f(s) = \frac{d}{ds} \phi(s) = \frac{d}{ds} \left(\frac{\mu}{\lambda} e^{-s/\lambda} \right) = -\frac{\mu}{\lambda^2} e^{-s/\lambda}. \quad (8.4.9)$$

For the linear Maxwell fluid with discrete relaxation spectra, the memory function is

$$f(s) = -\sum_{n=1}^N \frac{\mu_n}{\lambda_n^2} e^{-s/\lambda_n}. \quad (8.4.10)$$

and for the Maxwell fluid with a continuous spectrum,

$$f(s) = -\int_0^{\infty} \frac{H(\lambda)}{\lambda^2} e^{-s/\lambda} d\lambda. \quad (8.4.11)$$

We note that when we write $s \equiv t - t'$, Eq. (8.4.1) becomes

$$\mathbf{S} = 2 \int_0^{\infty} \phi(s) \mathbf{D}(t-s) ds. \quad (8.4.12)$$

Example 8.4.1

Obtain the storage modulus $G'(\omega)$ and the loss modulus $G''(\omega)$ for the linear Maxwell fluid with a continuous relaxation spectrum by subjecting the fluid to an oscillatory shearing strain described in Example 8.1.4.

Solution

From Example 8.1.4, the oscillatory shear component of the rate of deformation tensor is $D_{12} = (i\omega u_0/2h)e^{i\omega t}$. Thus, with $S_{12} = S e^{i\omega t}$, Eq. (8.4.12) gives

$$\frac{S}{(u_0/h)} = i\omega \int_0^{\infty} \phi(s) e^{-i\omega s} ds. \quad (8.4.13)$$

With the relaxation function given by $\phi(t) = \int_0^\infty (H(\tau)/\tau)e^{-t/\tau}d\tau$, the complex shear modulus is

$$\begin{aligned} G^* &\equiv \frac{S}{(u_0/h)} = i\omega \int_0^\infty \left[\int_0^\infty \frac{H(\tau)}{\tau} e^{-s/\tau} d\tau \right] e^{-i\omega s} ds = i\omega \int_0^\infty \frac{H(\tau)}{\tau} \left[\int_0^\infty e^{-(1+i\tau\omega)s} ds \right] d\tau \\ &= i\omega \int_0^\infty \frac{H(\tau)}{\tau} \left[-\frac{\tau e^{-(1+i\tau\omega)s/\tau}}{(1+i\tau\omega)} \Big|_{s=0}^\infty \right] d\tau = i\omega \int_0^\infty \frac{H(\tau)}{1+i\tau\omega} d\tau. \end{aligned}$$

That is,

$$G^* = \int_0^\infty \frac{\tau\omega^2 H(\tau)}{(1+\tau^2\omega^2)} d\tau + i \int_0^\infty \frac{\omega H(\tau)}{(1+\tau^2\omega^2)} d\tau. \quad (8.4.14)$$

Thus, the storage modulus is

$$G' = \int_0^\infty \frac{(\tau\omega)^2 H(\tau)}{\tau(1+\tau^2\omega^2)} d\tau, \quad (8.4.15)$$

and the loss modulus is

$$G'' = \int_0^\infty \frac{(\tau\omega)H(\tau)}{\tau(1+\tau^2\omega^2)} d\tau. \quad (8.4.16)$$

8.5 COMPUTATION OF RELAXATION SPECTRUM AND RELAXATION FUNCTION

Whenever either $G'(\omega)$ or $G''(\omega)$ is known (e.g., from experimental measurements), the relaxation spectrum $H(\tau)$ can be obtained from either Eq. (8.4.15) or Eq. (8.4.16). It has been found that numerically, it is better to invert $G''(\omega)$. The inversion procedure is as follows:

1. From the experimental data of $G''(\omega)$, use the following formula due to Tanner* as an approximate $H(\tau)$ to start the iteration procedure:

$$H(\tau_i)|_{\tau_i=1/\omega_i} = \frac{2}{\pi} G''(\omega_i) \quad \text{for } i = 1 \text{ and } N,$$

and

$$H(\tau_i)|_{\tau_i=1/\omega_i} = \frac{2}{3\pi} [G''(\omega_i/a) + G''(\omega_i) + G''(a\omega_i)] \quad \text{for } i = 2, 3, \dots (N-1),$$

where, for best results, choose the parameter a so that $\log a = 0.2$.

2. Substitute the $H(\tau)$ in Eq. (8.4.16) to calculate the new $G''(\omega)$ using, for example, Simpson's rule for numerical calculations. Let this calculated $G''(\omega)$ be denoted by $(G'')_{cal}$.
3. Calculate the difference $\Delta G'' = (G'')_{data} - (G'')_{cal}$.
4. Compute the correction ΔH_i :

$$\Delta H_i = \frac{2}{\pi} \Delta G''(\omega_i) \quad \text{for } i = 1 \text{ and } N,$$

*Tanner, R. I., *J. Appl. Polymer Sci.* 12, 1649, 1968.

and

$$\Delta H_i = \frac{2}{3\pi} [\Delta G''(\omega_i/a) + \Delta G''(\omega_i) + \Delta G''(a\omega_i)] \quad \text{for } i = 2, 3, \dots (N-1).$$

5. Obtain the new $H(\tau_i)$:

$$H_{new}(\tau_i) = H(\tau_i) + \Delta H(\tau_i).$$

6. Repeat step 2 using the newly obtained $H(\tau_i)$. Continue the iteration process until $(G'')_{cal}$ converges to $(G'')_{data}$ for a prescribed convergence criterion.
7. After $H(\tau)$ is obtained, the relaxation function $\phi(t)$ can be obtained from Eq. (8.4.1) by numerical integration.

Example 8.5.1

Synovial fluid is the fluid in the cavity of the synovial joints. It contains varying amounts of a hyaluronic acid-protein complex, which has an average molecular weight of about 2 million. This macromolecule forms ellipsoidal three-dimensional networks that occupy a solvent domain much larger than the volume of the polymer chain itself. This spatial arrangement endows synovial fluids with non-Newtonian fluid behaviors. Figure 8.5-1 shows the storage and loss modulus for synovial fluids in three clinical states: (A) young normal human knee sample, (B) old normal knee sample, and (C) osteoarthritic human knee sample.[†] Use the procedure described in this section to obtain the relaxation spectra and the relaxation functions for these fluids.

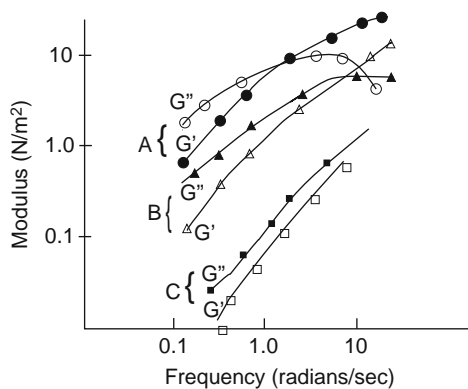

FIGURE 8.5-1 Experimental curves of G' and G'' for three synovial fluids.

Solution

The relaxation spectra and the relaxation functions for the three fluids have been obtained using the procedure described in this section. Table 8.5.1 shows the results; Figure 8.5-2 shows the calculated relaxation functions for these fluids.[‡]

[†]From Balazs, E. A., and Gibbs, D. A., *Chemistry and Molecular Biology of the Intercellular Matrix*, E. A. Balazs (ed.), Vol. 3, Academic Press, 1970, pp. 1241–1253.

[‡]Lai, W. M., Kuei, S. C., and Mow, V. C., *Biorheology* 14:229–236, 1977.

From both the experimental data and the calculated stress relaxation functions, we see that the osteoarthritic fluid can store less elastic energy and has less relaxation time. That is, compared with the normal fluids, its behaviors are closer to that of a Newtonian fluid.

τ	0.025	0.063	0.159	0.400	1.000	2.512	6.329	10.00	15.85
A	-3.77	1.01	11.09	7.03	3.36	1.88	0.65	0.21	0.087
B	-4.49	5.23	3.94	0.985	1.25	-0.083	0.169	0.128	-0.083
C	31.57	10.74	-4.15	1.78	0.722	0.282	-0.183	-0.014	0.060

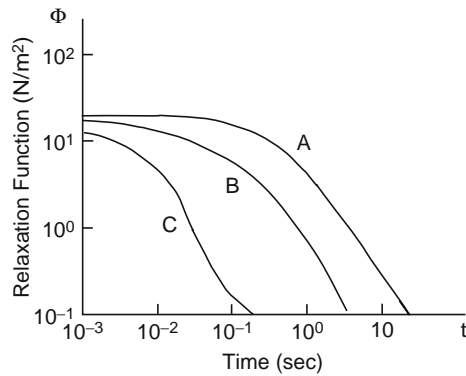

FIGURE 8.5-2 Calculated relaxation functions for three human synovial fluids.

PART B: NONLINEAR VISCOELASTIC FLUID

8.6 CURRENT CONFIGURATION AS REFERENCE CONFIGURATION

Let \mathbf{x} be the position vector of a particle at current time t , and let \mathbf{x}' be the position vector of the same particle at time τ . Then the equation

$$\mathbf{x}' = \mathbf{x}'_t(\mathbf{x}, \tau) \quad \text{with} \quad \mathbf{x} = \mathbf{x}'_t(\mathbf{x}, t) \tag{8.6.1}$$

defines the motion of a continuum using the current time t as the reference time. The subscript t in the function $\mathbf{x}'_t(\mathbf{x}, \tau)$ indicates that the current time t is the reference time, and as such $\mathbf{x}'_t(\mathbf{x}, \tau)$ is also a function of t .

For a given velocity field $\mathbf{v} = \mathbf{v}(\mathbf{x}, t)$, the velocity at position \mathbf{x}' at time τ is $\mathbf{v} = \mathbf{v}(\mathbf{x}', \tau)$. On the other hand, for a particular particle (i.e., for fixed \mathbf{x} and t), the velocity at time τ is given by $(\partial \mathbf{x}'_i / \partial \tau)_{\mathbf{x}, t - \text{fixed}}$. Thus,

$$\mathbf{v}(\mathbf{x}', \tau) = \frac{\partial \mathbf{x}'_i}{\partial \tau}. \quad (8.6.2)$$

Equation (8.6.2) allows one to obtain the pathline equations from a given velocity field, using the current time t as the reference time.

Example 8.6.1

Given the velocity field of the steady unidirectional flow:

$$v_1 = v(x_2), \quad v_2 = v_3 = 0. \quad (8.6.3)$$

Describe the motion of the particles by using the current time t as the reference time.

Solution

From the given velocity field, the velocity components at the position (x'_1, x'_2, x'_3) at time τ :

$$v_1 = v(x'_2), \quad v_2 = v_3 = 0. \quad (i)$$

Thus, with $\mathbf{x}' = x'_i \mathbf{e}_i$, Eq. (8.6.2) gives

$$\frac{\partial x'_1}{\partial \tau} = v(x'_2), \quad \frac{\partial x'_2}{\partial \tau} = \frac{\partial x'_3}{\partial \tau} = 0. \quad (ii)$$

From $\partial x'_2 / \partial \tau = \partial x'_3 / \partial \tau = 0$ and the initial conditions $x'_2 = x_2, x'_3 = x_3$ at $\tau = t$, we have, at all time τ ,

$$x'_2 = x_2 \quad \text{and} \quad x'_3 = x_3. \quad (iii)$$

Now, from $\partial x'_1 / \partial \tau = v(x'_2) = v(x_2)$, we get

$$x'_1 = v(x_2)\tau + g(x_1, x_2, x_3, t). \quad (iv)$$

At $\tau = t, x'_1 = x_1$, therefore, $x_1 = v(x_2)t + g(x_1, x_2, x_3, t)$, so that

$$g(x_1, x_2, x_3, t) = x_1 - v(x_2)t. \quad (v)$$

Thus,

$$x'_1 = x_1 + v(x_2)(\tau - t), \quad x'_2 = x_2, \quad x'_3 = x_3. \quad (8.6.4)$$

8.7 RELATIVE DEFORMATION GRADIENT

Let $d\mathbf{x}$ and $d\mathbf{x}'$ be the differential vectors representing the same material element at time t and τ , respectively. Then they are related by

$$d\mathbf{x}' = \mathbf{x}'_i(\mathbf{x} + d\mathbf{x}, \tau) - \mathbf{x}'_i(\mathbf{x}, \tau) = (\nabla \mathbf{x}'_i) d\mathbf{x}. \quad (8.7.1)$$

That is,

$$d\mathbf{x}' = \mathbf{F}_i d\mathbf{x}, \quad (8.7.2)$$

where

$$\mathbf{F}_t = \nabla \mathbf{x}'_t. \quad (8.7.3)$$

The tensor \mathbf{F}_t is known as the *relative deformation gradient*. Here, the adjective *relative* indicates that the deformation gradient is relative to the configuration at the current time. We note that for $\tau = t$, $d\mathbf{x}' = d\mathbf{x}$ so that

$$\mathbf{F}_t(t) = \mathbf{I}. \quad (8.7.4)$$

In rectangular Cartesian coordinates, with pathline equations given by

$$x'_1 = x'_1(x_1, x_2, x_3, \tau), \quad x'_2 = x'_2(x_1, x_2, x_3, \tau), \quad x'_3 = x'_3(x_1, x_2, x_3, \tau), \quad (8.7.5)$$

the matrix of $\mathbf{F}_t(\tau)$ is

$$[\mathbf{F}_t] = [\nabla \mathbf{x}'_t] = \begin{bmatrix} \frac{\partial x'_1}{\partial x_1} & \frac{\partial x'_1}{\partial x_2} & \frac{\partial x'_1}{\partial x_3} \\ \frac{\partial x'_2}{\partial x_1} & \frac{\partial x'_2}{\partial x_2} & \frac{\partial x'_2}{\partial x_3} \\ \frac{\partial x'_3}{\partial x_1} & \frac{\partial x'_3}{\partial x_2} & \frac{\partial x'_3}{\partial x_3} \end{bmatrix}. \quad (8.7.6)$$

In cylindrical coordinates, with pathline equations given by

$$r' = r'(r, \theta, z, \tau), \quad \theta' = \theta'(r, \theta, z, \tau), \quad z' = z'(r, \theta, z, \tau), \quad (8.7.7)$$

the two point components of \mathbf{F}_t with respect to $\{\mathbf{e}'_r, \mathbf{e}'_\theta, \mathbf{e}'_z\}$ at τ and $\{\mathbf{e}_r, \mathbf{e}_\theta, \mathbf{e}_z\}$ at t can be written down easily from Eq. (3.29.12) of Chapter 3 by noting the difference in the reference times. For example, $r = r(r_o, \theta_o, z_o, t)$ in Section 3.29 corresponds to $r' = r'(r, \theta, z, \tau)$ here in this section:

$$[\mathbf{F}_t] = \begin{bmatrix} \frac{\partial r'}{\partial r} & \frac{1}{r} \frac{\partial r'}{\partial \theta} & \frac{\partial r'}{\partial z} \\ \frac{r' \partial \theta'}{\partial r} & \frac{r' \partial \theta'}{r \partial \theta} & \frac{r' \partial \theta'}{\partial z} \\ \frac{\partial z'}{\partial r} & \frac{1}{r} \frac{\partial z'}{\partial \theta} & \frac{\partial z'}{\partial z} \end{bmatrix}. \quad (8.7.8)$$

In spherical coordinates, with pathline equations given by

$$r' = r'(r, \theta, \phi, \tau), \quad \theta' = \theta'(r, \theta, \phi, \tau), \quad \phi' = \phi'(r, \theta, \phi, \tau), \quad (8.7.9)$$

the two point components of \mathbf{F}_t with respect to $\{\mathbf{e}'_r, \mathbf{e}'_\theta, \mathbf{e}'_\phi\}$ at τ and $\{\mathbf{e}_r, \mathbf{e}_\theta, \mathbf{e}_\phi\}$ at t are given by the matrix

$$[\mathbf{F}_t] = \begin{bmatrix} \frac{\partial r'}{\partial r} & \frac{1}{r} \frac{\partial r'}{\partial \theta} & \frac{1}{r \sin \theta} \frac{\partial r'}{\partial \phi} \\ \frac{r' \partial \theta'}{\partial r} & \frac{r' \partial \theta'}{r \partial \theta} & \frac{r' \partial \theta'}{r \sin \theta \partial \phi} \\ \frac{r' \sin \theta' \partial \phi'}{\partial r} & \frac{r' \sin \theta' \partial \phi'}{r \partial \theta} & \frac{r' \sin \theta' \partial \phi'}{r \sin \theta \partial \phi} \end{bmatrix}. \quad (8.7.10)$$

8.8 RELATIVE DEFORMATION TENSORS

The descriptions of the relative deformation tensors (using the current time t as reference time) are similar to those of the deformation tensors using a fixed reference time (see Chapter 3, Sections 3.18 to 3.29). Indeed, by polar decomposition theorem (Section 3.21),

$$\mathbf{F}_t = \mathbf{R}_t \mathbf{U}_t = \mathbf{V}_t \mathbf{R}_t, \quad (8.8.1)$$

where \mathbf{U}_t and \mathbf{V}_t are relative right and left stretch tensors, respectively, and \mathbf{R}_t is the relative rotation tensor. We note that

$$\mathbf{F}_t(t) = \mathbf{U}_t(t) = \mathbf{V}_t(t) = \mathbf{R}_t(t) = \mathbf{I}. \quad (8.8.2)$$

From Eq. (8.8.1), we clearly also have

$$\mathbf{V}_t = \mathbf{R}_t \mathbf{U}_t \mathbf{R}_t^T \quad \text{and} \quad \mathbf{U}_t = \mathbf{R}_t^T \mathbf{V}_t \mathbf{R}_t. \quad (8.8.3)$$

The relative right Cauchy-Green deformation tensor \mathbf{C}_t is defined by

$$\mathbf{C}_t = \mathbf{F}_t^T \mathbf{F}_t = \mathbf{U}_t \mathbf{U}_t. \quad (8.8.4)$$

The relative left Cauchy-Green deformation tensor \mathbf{B}_t is defined by

$$\mathbf{B}_t = \mathbf{F}_t \mathbf{F}_t^T = \mathbf{V}_t \mathbf{V}_t. \quad (8.8.5)$$

The tensors \mathbf{C}_t and \mathbf{B}_t are related by

$$\mathbf{B}_t = \mathbf{R}_t \mathbf{C}_t \mathbf{R}_t^T \quad \text{and} \quad \mathbf{C}_t = \mathbf{R}_t^T \mathbf{B}_t \mathbf{R}_t. \quad (8.8.6)$$

The tensors \mathbf{C}_t^{-1} and \mathbf{B}_t^{-1} are often encountered in the literature. They are known as the *relative Finger deformation tensor* and the *relative Piola deformation tensor*, respectively.

We note that

$$\mathbf{C}_t(t) = \mathbf{B}_t(t) = \mathbf{C}_t^{-1}(t) = \mathbf{B}_t^{-1}(t) = \mathbf{I}. \quad (8.8.7)$$

Example 8.8.1

Show that if $d\mathbf{x}^{(1)}$ and $d\mathbf{x}^{(2)}$ are two material elements emanating from a point P at time t and $d\mathbf{x}'^{(1)}$ and $d\mathbf{x}'^{(2)}$ are the corresponding elements at time τ , then

$$d\mathbf{x}'^{(1)} \cdot d\mathbf{x}'^{(2)} = d\mathbf{x}^{(1)} \cdot \mathbf{C}_t d\mathbf{x}^{(2)} \quad (8.8.8)$$

and

$$d\mathbf{x}^{(1)} \cdot d\mathbf{x}^{(2)} = d\mathbf{x}'^{(1)} \cdot \mathbf{B}_t^{-1} d\mathbf{x}'^{(2)}. \quad (8.8.9)$$

Solution

From Eq. (8.7.2), we have

$$d\mathbf{x}'^{(1)} \cdot d\mathbf{x}'^{(2)} = \mathbf{F}_t d\mathbf{x}^{(1)} \cdot \mathbf{F}_t d\mathbf{x}^{(2)} = d\mathbf{x}^{(1)} \cdot \mathbf{F}_t^T \mathbf{F}_t d\mathbf{x}^{(2)}.$$

That is,

$$d\mathbf{x}'^{(1)} \cdot d\mathbf{x}'^{(2)} = d\mathbf{x}^{(1)} \cdot \mathbf{C}_t d\mathbf{x}^{(2)}.$$

Also, since $d\mathbf{x} = \mathbf{F}_t^{-1} d\mathbf{x}'$,

$$d\mathbf{x}^{(1)} \cdot d\mathbf{x}^{(2)} = \mathbf{F}_t^{-1} d\mathbf{x}'^{(1)} \cdot \mathbf{F}_t^{-1} d\mathbf{x}'^{(2)} = d\mathbf{x}'^{(1)} \cdot (\mathbf{F}_t^{-1})^\top \mathbf{F}_t^{-1} d\mathbf{x}'^{(2)} = d\mathbf{x}'^{(1)} \cdot (\mathbf{F}_t \mathbf{F}_t^\top)^{-1} d\mathbf{x}'^{(2)}.$$

That is,

$$d\mathbf{x}^{(1)} \cdot d\mathbf{x}^{(2)} = d\mathbf{x}'^{(1)} \cdot \mathbf{B}_t^{-1} d\mathbf{x}'^{(2)}.$$

Let $d\mathbf{x} = ds\mathbf{e}_1$ be a material element at the current time t and $d\mathbf{x}' = ds'\mathbf{n}$ be the same material element at time τ , where \mathbf{e}_1 is a unit base vector in a coordinate system and \mathbf{n} is a unit vector in the direction of the deformed vector. Then Eq. (8.8.8) gives

$$(ds'/ds)^2 = \mathbf{e}_1 \cdot \mathbf{C}_t \mathbf{e}_1 = (C_t)_{11}. \quad (8.8.10)$$

On the other hand, if $d\mathbf{x}' = ds'\mathbf{e}_1$ is a material element at time τ and $d\mathbf{x} = ds\mathbf{n}$ is the same material element at the current time t , then Eq. (8.8.9) gives

$$(ds/ds')^2 = \mathbf{e}_1 \cdot \mathbf{B}_t^{-1} \mathbf{e}_1 = (B_t^{-1})_{11}. \quad (8.8.11)$$

The meaning of the other components can also be obtained from Eqs. (8.8.8) and (8.8.9).

8.9 CALCULATIONS OF THE RELATIVE DEFORMATION TENSOR

A. Rectangular Coordinates

Let

$$x'_1 = x'_1(x_1, x_2, x_3, \tau), \quad x'_2 = x'_2(x_1, x_2, x_3, \tau), \quad x'_3 = x'_3(x_1, x_2, x_3, \tau) \quad (8.9.1)$$

be the pathline equations. Eqs. (8.8.4) and (8.7.6) give

$$(C_t)_{11} = \left(\frac{\partial x'_1}{\partial x_1} \right)^2 + \left(\frac{\partial x'_2}{\partial x_1} \right)^2 + \left(\frac{\partial x'_3}{\partial x_1} \right)^2, \quad (8.9.2)$$

$$(C_t)_{22} = \left(\frac{\partial x'_1}{\partial x_2} \right)^2 + \left(\frac{\partial x'_2}{\partial x_2} \right)^2 + \left(\frac{\partial x'_3}{\partial x_2} \right)^2, \quad (8.9.3)$$

$$(C_t)_{12} = \left(\frac{\partial x'_1}{\partial x_1} \right) \left(\frac{\partial x'_1}{\partial x_2} \right) + \left(\frac{\partial x'_2}{\partial x_1} \right) \left(\frac{\partial x'_2}{\partial x_2} \right) + \left(\frac{\partial x'_3}{\partial x_1} \right) \left(\frac{\partial x'_3}{\partial x_2} \right). \quad (8.9.4)$$

Other components can be similarly written.

The components of \mathbf{C}_t^{-1} can be obtained using the inverse function of Eq. (8.9.1), i.e.,

$$x_1 = x_1(x'_1, x'_2, x'_3, \tau), \quad x_2 = x_2(x'_1, x'_2, x'_3, \tau), \quad x_3 = x_3(x'_1, x'_2, x'_3, \tau). \quad (8.9.5)$$

They are

$$(C_t^{-1})_{11} = \left(\frac{\partial x_1}{\partial x'_1} \right)^2 + \left(\frac{\partial x_1}{\partial x'_2} \right)^2 + \left(\frac{\partial x_1}{\partial x'_3} \right)^2, \quad (8.9.6)$$

$$(C_t^{-1})_{22} = \left(\frac{\partial x_2}{\partial x'_1} \right)^2 + \left(\frac{\partial x_2}{\partial x'_2} \right)^2 + \left(\frac{\partial x_2}{\partial x'_3} \right)^2, \quad (8.9.7)$$

$$(C_t^{-1})_{12} = \left(\frac{\partial x_1}{\partial x'_1}\right)\left(\frac{\partial x_2}{\partial x'_1}\right) + \left(\frac{\partial x_1}{\partial x'_2}\right)\left(\frac{\partial x_2}{\partial x'_2}\right) + \left(\frac{\partial x_1}{\partial x'_3}\right)\left(\frac{\partial x_2}{\partial x'_3}\right). \quad (8.9.8)$$

Other components can be similarly written.

Example 8.9.1

Find the relative right Cauchy-Green deformation tensor and its inverse for the velocity field given in Eq. (8.6.3), i.e.,

$$v_1 = v(x_2), \quad v_2 = v_3 = 0. \quad (8.9.9)$$

Solution

In Example 8.6.1, we obtained the pathline equations for this velocity field to be [Eq. (8.6.4)]:

$$x'_1 = x_1 + v(x_2)(\tau - t), \quad x'_2 = x_2, \quad x'_3 = x_3, \quad (8.9.10)$$

with $k = dv/dx_2$, we have

$$[\mathbf{F}_t] = \begin{bmatrix} 1 & k(\tau - t) & 0 \\ 0 & 1 & 0 \\ 0 & 0 & 1 \end{bmatrix}. \quad (8.9.11)$$

Thus,

$$[\mathbf{C}_t] = [\mathbf{F}_t]^T [\mathbf{F}_t] = \begin{bmatrix} 1 & 0 & 0 \\ k(\tau - t) & 1 & 0 \\ 0 & 0 & 1 \end{bmatrix} \begin{bmatrix} 1 & k(\tau - t) & 0 \\ 0 & 1 & 0 \\ 0 & 0 & 1 \end{bmatrix} = \begin{bmatrix} 1 & k(\tau - t) & 0 \\ k(\tau - t) & k^2(\tau - t)^2 + 1 & 0 \\ 0 & 0 & 1 \end{bmatrix}. \quad (8.9.12)$$

The inverse of Eq. (8.6.4) is

$$x_1 = x'_1 - v(x_2)(\tau - t), \quad x_2 = x'_2, \quad x_3 = x'_3. \quad (8.9.13)$$

Thus,

$$[\mathbf{F}_t^{-1}] = \begin{bmatrix} 1 & -k(\tau - t) & 0 \\ 0 & 1 & 0 \\ 0 & 0 & 1 \end{bmatrix}, \quad (8.9.14)$$

$$[\mathbf{C}_t^{-1}] = \mathbf{F}_t^{-1} [\mathbf{F}_t^{-1}]^T = \begin{bmatrix} 1 & -k(\tau - t) & 0 \\ 0 & 1 & 0 \\ 0 & 0 & 1 \end{bmatrix} \begin{bmatrix} 1 & 0 & 0 \\ -k(\tau - t) & 1 & 0 \\ 0 & 0 & 1 \end{bmatrix} = \begin{bmatrix} 1 + k^2(\tau - t)^2 & -k(\tau - t) & 0 \\ -k(\tau - t) & 1 & 0 \\ 0 & 0 & 1 \end{bmatrix}. \quad (8.9.15)$$

B. Cylindrical Coordinates

For pathline equations given as

$$r' = r'(r, \theta, z, \tau), \quad \theta' = \theta'(r, \theta, z, \tau), \quad z' = z'(r, \theta, z, \tau), \quad (8.9.16)$$

the components of \mathbf{C}_t with respect to $\{\mathbf{e}_r, \mathbf{e}_\theta, \mathbf{e}_z\}$ at t can be written easily from the equations given in Chapter 3, Section 3.29, for cylindrical coordinates. Attention should be paid, however, that in Section 3.29, (r, θ, z)

and (r_o, θ_o, z_o) are the coordinates at t and t_o (where t_o is the reference time), respectively, whereas in this section (r', θ', z') and (r, θ, z) are the coordinates at τ and t (where t is the reference time), respectively. For example, $r = r(r_o, \theta_o, z_o, t)$ in Section 3.29 corresponds to $r' = r'(r, \theta, z, \tau)$ here in this section. Thus,

$$(C_t)_{rr} = \left(\frac{\partial r'}{\partial r}\right)^2 + \left(r' \frac{\partial \theta'}{\partial r}\right)^2 + \left(\frac{\partial z'}{\partial r}\right)^2, (C_t)_{\theta\theta} = \frac{1}{r^2} \left[\left(\frac{\partial r'}{\partial \theta}\right)^2 + \left(r' \frac{\partial \theta'}{\partial \theta}\right)^2 + \left(\frac{\partial z'}{\partial \theta}\right)^2 \right], \quad (8.9.17)$$

$$(C_t)_{r\theta} = \frac{1}{r} \left[\left(\frac{\partial r'}{\partial r}\right) \left(\frac{\partial r'}{\partial \theta}\right) + r'^2 \left(\frac{\partial \theta'}{\partial r}\right) \left(\frac{\partial \theta'}{\partial \theta}\right) + \left(\frac{\partial z'}{\partial r}\right) \left(\frac{\partial z'}{\partial \theta}\right) \right], \text{ etc.} \quad (8.9.18)$$

Similarly, with the inverse of Eq. (8.9.16) given by

$$r = r(r', \theta', z', \tau), \quad \theta = \theta(r', \theta', z', \tau), \quad z = z(r', \theta', z', \tau), \quad (8.9.19)$$

the components of C_t^{-1} are given by

$$(C_t^{-1})_{rr} = \left(\frac{\partial r}{\partial r'}\right)^2 + \left(\frac{1}{r'} \frac{\partial r}{\partial \theta'}\right)^2 + \left(\frac{\partial r}{\partial z'}\right)^2, \quad (C_t^{-1})_{\theta\theta} = \left[\left(\frac{r \partial \theta}{\partial r'}\right)^2 + \left(\frac{r}{r'} \frac{\partial \theta}{\partial \theta'}\right)^2 + \left(r \frac{\partial \theta}{\partial z'}\right)^2 \right] \quad (8.9.20)$$

$$(C_t^{-1})_{r\theta} = \left(\frac{\partial r}{\partial r'}\right) \left(r \frac{\partial \theta}{\partial r'}\right) + \left(\frac{1}{r'} \frac{\partial r}{\partial \theta'}\right) \left(\frac{r}{r'} \frac{\partial \theta}{\partial \theta'}\right) + \left(\frac{\partial r}{\partial z'}\right) \left(r \frac{\partial \theta}{\partial z'}\right), \text{ etc.} \quad (8.9.21)$$

C. Spherical Coordinates

For pathline equations given as

$$r' = r'(r, \theta, \phi, \tau), \quad \theta' = \theta'(r, \theta, \phi, \tau), \quad \phi' = \phi'(r, \theta, \phi, \tau), \quad (8.9.22)$$

the components of C_t with respect to $\{\mathbf{e}_r, \mathbf{e}_\theta, \mathbf{e}_\phi\}$ can be written down easily from the equations given in Chapter 3, Section 3.29, for spherical coordinates. Attention should be paid, however, that in Section 3.29, (r, θ, ϕ) and (r_o, θ_o, ϕ_o) are the coordinates at t and t_o (where t_o is the reference time), respectively, whereas in this section (r', θ', ϕ') and (r, θ, ϕ) are the coordinates at τ and t (where t is the reference time), respectively. For example, $r = r(r_o, \theta_o, \phi_o, t)$ in Section 3.29 corresponds to $r' = r'(r, \theta, \phi, \tau)$ here in this section. Thus,

$$(C_t)_{rr} = \left(\frac{\partial r'}{\partial r}\right)^2 + \left(r' \frac{\partial \theta'}{\partial r}\right)^2 + \left(r' \sin \theta' \frac{\partial \phi'}{\partial r}\right)^2, \quad (8.9.23)$$

$$(C_t)_{\theta\theta} = \frac{1}{r^2} \left[\left(\frac{\partial r'}{\partial \theta}\right)^2 + \left(r' \frac{\partial \theta'}{\partial \theta}\right)^2 + \left(r' \sin \theta' \frac{\partial \phi'}{\partial \theta}\right)^2 \right], \quad (8.9.24)$$

$$(C_t)_{r\theta} = \frac{1}{r} \left[\left(\frac{\partial r'}{\partial r}\right) \left(\frac{\partial r'}{\partial \theta}\right) + r'^2 \left(\frac{\partial \theta'}{\partial r}\right) \left(\frac{\partial \theta'}{\partial \theta}\right) + (r' \sin \theta')^2 \left(\frac{\partial \phi'}{\partial r}\right) \left(\frac{\partial \phi'}{\partial \theta}\right) \right], \text{ etc.} \quad (8.9.25)$$

Similarly, with the inverse of Eq. (8.9.22) given by

$$r = r(r', \theta', \phi', \tau), \quad \theta = \theta(r', \theta', \phi', \tau), \quad \phi = \phi(r', \theta', \phi', \tau), \quad (8.9.26)$$

the components of \mathbf{C}_t^{-1} are given by

$$(C_t^{-1})_{rr} = \left(\frac{\partial r}{\partial r'}\right)^2 + \left(\frac{1}{r'} \frac{\partial r}{\partial \theta'}\right)^2 + \left(\frac{1}{r' \sin \theta'} \frac{\partial r}{\partial \phi'}\right)^2, \quad (8.9.27)$$

$$(C_t^{-1})_{\theta\theta} = \left[\left(\frac{r \partial \theta}{\partial r'}\right)^2 + \left(\frac{r}{r'} \frac{\partial \theta}{\partial \theta'}\right)^2 + \left(\frac{r}{r' \sin \theta'} \frac{\partial \theta}{\partial \phi'}\right)^2 \right], \quad (8.9.28)$$

$$(C_t^{-1})_{r\theta} = \left(\frac{\partial r}{\partial r'}\right) \left(r \frac{\partial \theta}{\partial r'}\right) + \left(\frac{1}{r'} \frac{\partial r}{\partial \theta'}\right) \left(\frac{r}{r'} \frac{\partial \theta}{\partial \theta'}\right) + \left(\frac{1}{r' \sin \theta'} \frac{\partial r}{\partial \phi'}\right) \left(\frac{r}{r' \sin \theta'} \frac{\partial \theta}{\partial \phi'}\right). \quad (8.9.29)$$

Other components can be written easily following the patterns given in the preceding equations.

8.10 HISTORY OF THE RELATIVE DEFORMATION TENSOR AND RIVLIN-ERICKSEN TENSORS

The tensor $\mathbf{C}_t(\mathbf{x}, \tau)$ describes the deformation at time τ of the element which at time t , is at \mathbf{x} . Thus, as one varies τ from $\tau = -\infty$ to $\tau = t$ in the function $\mathbf{C}_t(\mathbf{x}, \tau)$, one gets the whole history of the deformation, from infinitely long ago to the present time t .

If we assume that we can expand the components of \mathbf{C}_t in the Taylor series about $\tau = t$, we have

$$\mathbf{C}_t(\mathbf{x}, \tau) = \mathbf{C}_t(\mathbf{x}, t) + \left(\frac{\partial \mathbf{C}_t}{\partial \tau}\right)_{\tau=t} (\tau - t) + \frac{1}{2} \left(\frac{\partial^2 \mathbf{C}_t}{\partial \tau^2}\right)_{\tau=t} (\tau - t)^2 + \dots \quad (8.10.1)$$

Let

$$\mathbf{A}_1 = \left(\frac{\partial \mathbf{C}_t}{\partial \tau}\right)_{\tau=t}, \quad \mathbf{A}_2 = \left(\frac{\partial^2 \mathbf{C}_t}{\partial \tau^2}\right)_{\tau=t} \dots \mathbf{A}_N = \left(\frac{\partial^N \mathbf{C}_t}{\partial \tau^N}\right)_{\tau=t}; \quad (8.10.2)$$

Eq. (8.10.1) then becomes

$$\mathbf{C}_t(\mathbf{x}, \tau) = \mathbf{I} + (\tau - t)\mathbf{A}_1 + \frac{(\tau - t)^2}{2} \mathbf{A}_2 + \dots \quad (8.10.3)$$

The tensors \mathbf{A}_N are known as the *Rivlin-Ericksen tensors*. We see from Eq. (8.10.3) that, provided the Taylor series expansion is valid, the Rivlin-Ericksen tensors \mathbf{A}_N 's ($N = 1$ to ∞) determine the history of relative deformation. It should be noted, however, that not all histories of relative deformation can be expanded in the Taylor series. For example, the stress relaxation test, in which a sudden jump in deformation is imposed on the fluid, has a history of relative deformation that cannot be represented by a Taylor series.

Example 8.10.1

The relative right Cauchy-Green tensor for the steady unidirectional flow given by the velocity field $v_1 = v(x_2)$, $v_2 = v_3 = 0$ has been found in Example 8.9.1 to be

$$[\mathbf{C}_t] = \begin{bmatrix} 1 & k(\tau - t) & 0 \\ k(\tau - t) & k^2(\tau - t)^2 + 1 & 0 \\ 0 & 0 & 1 \end{bmatrix},$$

where $k = dv/dx_2$. Find the Rivlin-Ericksen tensors for this flow.

Solution

$$[\mathbf{C}_t] = \begin{bmatrix} 1 & k(\tau - t) & 0 \\ k(\tau - t) & k^2(\tau - t)^2 + 1 & 0 \\ 0 & 0 & 1 \end{bmatrix} = \begin{bmatrix} 1 & 0 & 0 \\ 0 & 1 & 0 \\ 0 & 0 & 1 \end{bmatrix} + \begin{bmatrix} 0 & k & 0 \\ k & 0 & 0 \\ 0 & 0 & 0 \end{bmatrix} (\tau - t) + \begin{bmatrix} 0 & 0 & 0 \\ 0 & 2k^2 & 0 \\ 0 & 0 & 0 \end{bmatrix} \frac{(\tau - t)^2}{2}.$$

Thus [see Eq. (8.10.3)],

$$[\mathbf{A}_1] = \begin{bmatrix} 0 & k & 0 \\ k & 0 & 0 \\ 0 & 0 & 0 \end{bmatrix}, \quad [\mathbf{A}_2] = \begin{bmatrix} 0 & 0 & 0 \\ 0 & 2k^2 & 0 \\ 0 & 0 & 0 \end{bmatrix}, \quad [\mathbf{A}_N] = \begin{bmatrix} 0 & 0 & 0 \\ 0 & 0 & 0 \\ 0 & 0 & 0 \end{bmatrix} = [0] \quad \text{for all } N \geq 3,$$

and

$$[\mathbf{C}_t] = [\mathbf{I}] + [\mathbf{A}_1](\tau - t) + [\mathbf{A}_2] \frac{(\tau - t)^2}{2}.$$

Example 8.10.2

Given an axisymmetric velocity field in cylindrical coordinates:

$$v_r = 0, \quad v_\theta = 0, \quad v_z = v(r). \quad (\text{i})$$

- (a) Obtain the pathline equations using current time t as reference.
- (b) Compute the relative deformation tensor \mathbf{C}_t .
- (c) Find the Rivlin-Ericksen tensors.

Solution

- (a) Let the pathline equations be

$$r' = r'(r, \theta, z, \tau), \quad \theta' = \theta'(r, \theta, z, \tau), \quad z' = z'(r, \theta, z, \tau). \quad (\text{ii})$$

Then, from the given velocity field, we have

$$\frac{dr'}{d\tau} = 0, \quad \frac{d\theta'}{d\tau} = 0, \quad \frac{dz'}{d\tau} = v(r'). \quad (\text{iii})$$

Integration of these equations with the conditions that at $\tau = t$: $r' = r$, $\theta' = \theta$ and $z' = z$, we obtain

$$r' = r, \quad \theta' = \theta \quad \text{and} \quad z' = z + v(r)(\tau - t). \quad (\text{iv})$$

- (b) Using Eqs. (8.9.17), (8.9.18), etc., we obtain, with $k(r) = dv/dr$,

$$(C_t)_{rr} = \left(\frac{\partial r'}{\partial r} \right)^2 + \left(r' \frac{\partial \theta'}{\partial r} \right)^2 + \left(\frac{\partial z'}{\partial r} \right)^2 = 1 + 0 + (dv/dr)(\tau - t),$$

$$(C_t)_{\theta\theta} = \frac{1}{r^2} \left[\left(\frac{\partial r'}{\partial \theta} \right)^2 + \left(r' \frac{\partial \theta'}{\partial \theta} \right)^2 + \left(\frac{\partial z'}{\partial \theta} \right)^2 \right] = \frac{1}{r^2} [0 + (r')^2 + 0] = \frac{r^2}{r^2} = 1,$$

$$(C_t)_{zz} = \left[\left(\frac{\partial r'}{\partial z} \right)^2 + \left(r' \frac{\partial \theta'}{\partial z} \right)^2 + \left(\frac{\partial z'}{\partial z} \right)^2 \right] = 0 + 0 + 1 = 1,$$

$$(C_t)_{r\theta} = \frac{1}{r} \left[\left(\frac{\partial r'}{\partial r} \right) \left(\frac{\partial r'}{\partial \theta} \right) + r'^2 \left(\frac{\partial \theta'}{\partial r} \right) \left(\frac{\partial \theta'}{\partial \theta} \right) + \left(\frac{\partial z'}{\partial r} \right) \left(\frac{\partial z'}{\partial \theta} \right) \right] = 0 + 0 + 0 = 0,$$

$$(C_t)_{rz} = \left[\left(\frac{\partial r'}{\partial r} \right) \left(\frac{\partial r'}{\partial z} \right) + r'^2 \left(\frac{\partial \theta'}{\partial r} \right) \left(\frac{\partial \theta'}{\partial z} \right) + \left(\frac{\partial z'}{\partial r} \right) \left(\frac{\partial z'}{\partial z} \right) \right] = 0 + 0 + (dv/dr)(\tau - t)(1),$$

$$(C_t)_{\theta z} = \left[\left(\frac{\partial r'}{r \partial \theta} \right) \left(\frac{\partial r'}{\partial z} \right) + r'^2 \left(\frac{\partial \theta'}{r \partial \theta} \right) \left(\frac{\partial \theta'}{\partial z} \right) + \left(\frac{\partial z'}{r \partial \theta} \right) \left(\frac{\partial z'}{\partial z} \right) \right] = 0 + 0 + 0 = 0.$$

That is,

$$[\mathbf{C}_t] = \begin{bmatrix} 1 + k^2(\tau - t)^2 & 0 & k(\tau - t) \\ 0 & 1 & 0 \\ k(\tau - t) & 0 & 1 \end{bmatrix}. \quad (\text{v})$$

$$(c) \quad [\mathbf{C}_t] = \begin{bmatrix} 1 & 0 & 0 \\ 0 & 1 & 0 \\ 0 & 0 & 1 \end{bmatrix} + \begin{bmatrix} 0 & 0 & k \\ 0 & 0 & 0 \\ k & 0 & 0 \end{bmatrix} (\tau - t) + \begin{bmatrix} 2k^2 & 0 & 0 \\ 0 & 0 & 0 \\ 0 & 0 & 0 \end{bmatrix} \frac{(\tau - t)^2}{2}, \quad (\text{vi})$$

thus,

$$[\mathbf{A}_1] = \begin{bmatrix} 0 & 0 & k \\ 0 & 0 & 0 \\ k & 0 & 0 \end{bmatrix}, \quad [\mathbf{A}_2] = \begin{bmatrix} 2k^2 & 0 & 0 \\ 0 & 0 & 0 \\ 0 & 0 & 0 \end{bmatrix}, \quad [\mathbf{A}_N] = 0 \quad \text{for } N \geq 3. \quad (\text{vii})$$

Example 8.10.3

Consider the Couette flow with a velocity field given in cylindrical coordinates as

$$v_r = 0, \quad v_\theta = v(r), \quad v_z = 0. \quad (\text{i})$$

- (a) Obtain the pathline equations using current time t as reference.
- (b) Compute the relative deformation tensor \mathbf{C}_t .
- (c) Find the Rivlin-Ericksen tensors.

Solution

(a) Let the pathline equations be

$$r' = r'(r, \theta, z, \tau), \quad \theta' = \theta'(r, \theta, z, \tau), \quad z' = z'(r, \theta, z, \tau), \quad (\text{ii})$$

then, from the given velocity field, we have

$$\frac{dr'}{d\tau} = 0, \quad r' \frac{d\theta'}{d\tau} = v(r'), \quad \frac{dz'}{d\tau} = 0. \quad (\text{iii})$$

Integration of these equations with the conditions that at $\tau = t$: $r' = r$, $\theta' = \theta$ and $z' = z$, we obtain

$$r' = r, \quad \theta' = \theta + \frac{v(r)}{r}(\tau - t), \quad z' = z. \quad (\text{iv})$$

(b) Using Eqs. (8.9.17), (8.9.18), etc., we obtain

$$(C_t)_{rr} = \left(\frac{\partial r'}{\partial r}\right)^2 + \left(r' \frac{\partial \theta'}{\partial r}\right)^2 + \left(\frac{\partial z'}{\partial r}\right)^2 = 1 + \left(r \left[-\frac{v}{r^2} + \frac{dv/dr}{r}\right](\tau - t)\right)^2 = 1 + \left(\frac{dv}{dr} - \frac{v}{r}\right)^2 (\tau - t)^2,$$

$$(C_t)_{\theta\theta} = \frac{1}{r^2} \left[\left(\frac{\partial r'}{\partial \theta}\right)^2 + \left(r' \frac{\partial \theta'}{\partial \theta}\right)^2 + \left(\frac{\partial z'}{\partial \theta}\right)^2 \right] = \frac{1}{r^2} [0 + (r')^2 + 0] = \frac{r^2}{r^2} = 1,$$

$$(C_t)_{zz} = \left[\left(\frac{\partial r'}{\partial z}\right)^2 + \left(r' \frac{\partial \theta'}{\partial z}\right)^2 + \left(\frac{\partial z'}{\partial z}\right)^2\right] = 0 + 0 + 1 = 1,$$

$$(C_t)_{r\theta} = \frac{1}{r} \left[\left(\frac{\partial r'}{\partial r}\right) \left(\frac{\partial r'}{\partial \theta}\right) + r'^2 \left(\frac{\partial \theta'}{\partial r}\right) \left(\frac{\partial \theta'}{\partial \theta}\right) + \left(\frac{\partial z'}{\partial r}\right) \left(\frac{\partial z'}{\partial \theta}\right) \right] = \left(\frac{dv}{dr} - \frac{v}{r}\right)(\tau - t),$$

$$(C_t)_{rz} = \left[\left(\frac{\partial r'}{\partial r}\right) \left(\frac{\partial r'}{\partial z}\right) + r'^2 \left(\frac{\partial \theta'}{\partial r}\right) \left(\frac{\partial \theta'}{\partial z}\right) + \left(\frac{\partial z'}{\partial r}\right) \left(\frac{\partial z'}{\partial z}\right) \right] = 0,$$

$$(C_t)_{\theta z} = \left[\left(\frac{\partial r'}{\partial \theta}\right) \left(\frac{\partial r'}{\partial z}\right) + r'^2 \left(\frac{\partial \theta'}{\partial \theta}\right) \left(\frac{\partial \theta'}{\partial z}\right) + \left(\frac{\partial z'}{\partial \theta}\right) \left(\frac{\partial z'}{\partial z}\right) \right] = 0.$$

That is,

$$[\mathbf{C}_t] = \begin{bmatrix} 1 + k^2(\tau - t)^2 & k(\tau - t) & 0 \\ k(\tau - t) & 1 & 0 \\ 0 & 0 & 1 \end{bmatrix}, \quad k = \left(\frac{dv}{dr} - \frac{v}{r}\right). \quad (\text{v})$$

(c)

$$[\mathbf{c}_t] = \begin{bmatrix} 1 & 0 & 0 \\ 0 & 1 & 0 \\ 0 & 0 & 1 \end{bmatrix} + \begin{bmatrix} 0 & k & 0 \\ k & 0 & 0 \\ 0 & 0 & 0 \end{bmatrix} (\tau - t) + \begin{bmatrix} 2k^2 & 0 & 0 \\ 0 & 0 & 0 \\ 0 & 0 & 0 \end{bmatrix} \frac{(\tau - t)^2}{2}, \quad (\text{vi})$$

thus,

$$[\mathbf{A}_1] = \begin{bmatrix} 0 & k & 0 \\ k & 0 & 0 \\ 0 & 0 & 0 \end{bmatrix}, \quad [\mathbf{A}_2] = \begin{bmatrix} 2k^2 & 0 & 0 \\ 0 & 0 & 0 \\ 0 & 0 & 0 \end{bmatrix}, \quad [\mathbf{A}_N] = 0 \quad \text{for } N \geq 3, \quad (\text{vii})$$

where $k = \left(\frac{dv}{dr} - \frac{v}{r}\right)$.

Example 8.10.4

Given the velocity field of a sink flow in spherical coordinates:

$$v_r = -\frac{a}{r^2}, \quad v_\theta = 0, \quad v_\phi = 0. \quad (\text{i})$$

- (a) Obtain the pathline equations using current time t as reference.
 (b) Compute the relative deformation tensor \mathbf{C}_t .
 (c) Find the Rivlin-Ericksen tensors.

Solution

- (a) Let the pathline equations be

$$r' = r'(r, \theta, \phi, \tau), \quad \theta' = \theta'(r, \theta, \phi, \tau), \quad z' = z'(r, \theta, \phi, \tau), \quad (\text{ii})$$

then, from the given velocity field, we have

$$\frac{dr'}{d\tau} = -\frac{a}{r'^2}, \quad \frac{d\theta'}{d\tau} = 0, \quad \frac{d\phi'}{d\tau} = 0. \quad (\text{iii})$$

Integration of these equations with the conditions that at $\tau = t$, $r' = r$, $\theta' = \theta$ and $z' = z$, we obtain

$$r'^3 = 3a(t - \tau) + r^3, \quad \theta' = \theta, \quad \phi' = \phi. \quad (\text{iv})$$

- (b) Using Eqs. (8.9.23), (8.9.24), (8.9.25), etc., we have

$$(C_t)_{rr} = \left(\frac{\partial r'}{\partial r}\right)^2 + \left(r' \frac{\partial \theta'}{\partial r}\right)^2 + \left(r' \sin \theta' \frac{\partial \phi'}{\partial r}\right)^2 = \left(\frac{r^2}{r'^2}\right)^2 = \frac{r^4}{[r^3 + 3a(t - \tau)]^{4/3}}, \quad (\text{v})$$

$$(C_t)_{\theta\theta} = \frac{1}{r^2} \left[\left(\frac{\partial r'}{\partial \theta}\right)^2 + \left(r' \frac{\partial \theta'}{\partial \theta}\right)^2 + \left(r' \sin \theta' \frac{\partial \phi'}{\partial \theta}\right)^2 \right] = \frac{r'^2}{r^2} = \frac{[3a(t - \tau) + r^3]^{2/3}}{r^2}, \quad (\text{vi})$$

$$(C_t)_{\phi\phi} = \frac{1}{r^2 \sin^2 \theta} \left[\left(\frac{\partial r'}{\partial \phi}\right)^2 + \left(r' \frac{\partial \theta'}{\partial \phi}\right)^2 + \left(r' \sin \theta' \frac{\partial \phi'}{\partial \phi}\right)^2 \right] = \frac{r'^2 \sin^2 \theta'}{r^2 \sin^2 \theta} = \frac{r'^2}{r^2} = (C_t)_{\theta\theta}, \quad (\text{vii})$$

$$(C_t)_{r\theta} = \frac{1}{r} \left[\left(\frac{\partial r'}{\partial r}\right) \left(\frac{\partial r'}{\partial \theta}\right) + r'^2 \left(\frac{\partial \theta'}{\partial r}\right) \left(\frac{\partial \theta'}{\partial \theta}\right) + (r' \sin \theta')^2 \left(\frac{\partial \phi'}{\partial r}\right) \left(\frac{\partial \phi'}{\partial \theta}\right) \right] = 0, \quad (\text{viii})$$

$$(C_t)_{r\phi} = \frac{1}{r \sin \theta} \left[\left(\frac{\partial r'}{\partial r}\right) \left(\frac{\partial r'}{\partial \phi}\right) + r'^2 \left(\frac{\partial \theta'}{\partial r}\right) \left(\frac{\partial \theta'}{\partial \phi}\right) + (r' \sin \theta')^2 \left(\frac{\partial \phi'}{\partial r}\right) \left(\frac{\partial \phi'}{\partial \phi}\right) \right] = 0, \quad (\text{ix})$$

$$(C_t)_{\theta\phi} = \frac{1}{r^2 \sin \theta} \left[\left(\frac{\partial r'}{\partial \theta}\right) \left(\frac{\partial r'}{\partial \phi}\right) + r'^2 \left(\frac{\partial \theta'}{\partial \theta}\right) \left(\frac{\partial \theta'}{\partial \phi}\right) + (r' \sin \theta')^2 \left(\frac{\partial \phi'}{\partial \theta}\right) \left(\frac{\partial \phi'}{\partial \phi}\right) \right] = 0. \quad (\text{x})$$

(c) $(\mathbf{A}_1)_{rr} = \left[\frac{d(C_t)_{rr}}{d\tau} \right]_{\tau=t} = [4ar^4 \{r^3 + 3a(t - \tau)\}^{-7/3}]_{\tau=t} = 4ar^{-3}, \quad (\text{xi})$

$$(\mathbf{A}_1)_{\theta\theta} = \left[\frac{d(C_t)_{\theta\theta}}{d\tau} \right]_{\tau=t} = \left[-\frac{2a}{r^2} [3a(t - \tau) + r^3]^{-1/3} \right]_{\tau=t} = -\frac{2a}{r^3} = (\mathbf{A}_1)_{\phi\phi}, \quad (\text{xii})$$

$$(\mathbf{A}_2)_{rr} = \left[\frac{d^2(C_t)_{rr}}{d\tau^2} \right]_{\tau=t} = \left[28a^2 r^4 \{r^3 + 3a(t - \tau)\}^{-10/3} \right]_{\tau=t} = 28a^2 r^{-6}, \quad (\text{xiii})$$

$$(\mathbf{A}_2)_{\theta\theta} = \left[\frac{d^2(C_t)_{\theta\theta}}{d\tau^2} \right]_{\tau=t} = \left[-\frac{2a^2}{r^2} [3a(t - \tau) + r^3]^{-4/3} \right]_{\tau=t} = -\frac{2a^2}{r^6} = (\mathbf{A}_2)_{\phi\phi}, \quad (\text{xiv})$$

$$(\mathbf{A}_2)_{r\theta} = (\mathbf{A}_2)_{r\phi} = (\mathbf{A}_2)_{\phi\theta} = 0. \quad (\text{xv})$$

By computing the higher derivatives of the components of \mathbf{C}_t and evaluating them at $\tau = t$, one can obtain $\mathbf{A}_3, \mathbf{A}_4 \dots$, etc. We note that along each radial pathline, the base vectors are fixed.

8.11 RIVLIN-ERICKSEN TENSORS IN TERMS OF VELOCITY GRADIENT: THE RECURSIVE FORMULA

In this section, we show that

$$\mathbf{A}_1 = 2\mathbf{D} = \nabla\mathbf{v} + (\nabla\mathbf{v})^T, \quad (8.11.1)$$

$$\mathbf{A}_2 = \frac{D\mathbf{A}_1}{Dt} + \mathbf{A}_1(\nabla\mathbf{v}) + (\nabla\mathbf{v})^T\mathbf{A}_1, \quad (8.11.2)$$

and

$$\mathbf{A}_{N+1} = \frac{D\mathbf{A}_N}{Dt} + \mathbf{A}_N(\nabla\mathbf{v}) + (\nabla\mathbf{v})^T\mathbf{A}_N, \quad N = 1, 2, 3, \dots, \quad (8.11.3)$$

where $\nabla\mathbf{v}$ is the velocity gradient and \mathbf{D} is the rate of deformation tensor.

We have, at any time τ ,

$$ds'^2 = d\mathbf{x}' \cdot d\mathbf{x}' = d\mathbf{x} \cdot \mathbf{C}_t d\mathbf{x}, \quad (8.11.4)$$

thus [see Eq. (8.10.2)],

$$\frac{D(ds'^2)}{D\tau} \equiv \left[\frac{\partial}{\partial\tau} ds'^2 \right]_{x_i\text{-fixed}} = d\mathbf{x} \cdot \left(\frac{\partial\mathbf{C}_t}{\partial\tau} \right)_{x_i\text{-fixed}} d\mathbf{x},$$

$$\frac{D^2(ds'^2)}{D\tau^2} \equiv \left[\frac{\partial^2}{\partial\tau^2} ds'^2 \right]_{x_i\text{-fixed}} = d\mathbf{x} \cdot \left(\frac{\partial^2\mathbf{C}_t}{\partial\tau^2} \right)_{x_i\text{-fixed}} d\mathbf{x},$$

and in general,

$$\frac{D^N(ds'^2)}{D\tau^N} \equiv \left[\frac{\partial^N}{\partial\tau^N} ds'^2 \right]_{x_i\text{-fixed}} = d\mathbf{x} \cdot \left(\frac{\partial^N\mathbf{C}_t}{\partial\tau^N} \right)_{x_i\text{-fixed}} d\mathbf{x}. \quad (8.11.5)$$

Now, at $\tau = t$,

$$\left[\frac{\partial}{\partial\tau} ds'^2 \right]_{x_i\text{-fixed}} \Big|_{\tau=t} = \frac{D}{Dt} ds, \quad \left[\frac{\partial^2}{\partial\tau^2} ds'^2 \right]_{x_i\text{-fixed}} \Big|_{\tau=t} = \frac{D^2}{Dt^2} ds, \quad \left[\frac{\partial^N}{\partial\tau^N} ds'^2 \right]_{x_i\text{-fixed}} \Big|_{\tau=t} = \frac{D^N}{Dt^N} ds, \quad (8.11.6)$$

therefore,

$$\frac{D(ds)^2}{Dt} = d\mathbf{x} \cdot \mathbf{A}_1 d\mathbf{x}, \quad \frac{D^2(ds)^2}{Dt^2} = d\mathbf{x} \cdot \mathbf{A}_2 d\mathbf{x}, \quad \frac{D^N(ds)^2}{Dt^N} = d\mathbf{x} \cdot \mathbf{A}_N d\mathbf{x}. \quad (8.11.7)$$

In Chapter 3, we obtained [Eq. (3.13.11)],

$$\frac{D(ds)^2}{Dt} = 2d\mathbf{x} \cdot \mathbf{D}d\mathbf{x}, \quad \text{where } \mathbf{D} = \frac{1}{2}[\nabla\mathbf{v} + (\nabla\mathbf{v})^T],$$

thus,

$$\mathbf{A}_1 = 2\mathbf{D}. \quad (8.11.8)$$

Next, from the first equation in Eqs. (8.11.7), we have

$$\frac{D^2(ds)^2}{Dt^2} = \frac{Dd\mathbf{x}}{Dt} \cdot \mathbf{A}_1 d\mathbf{x} + d\mathbf{x} \cdot \frac{D\mathbf{A}_1}{Dt} d\mathbf{x} + d\mathbf{x} \cdot \mathbf{A}_1 \frac{Dd\mathbf{x}}{Dt}.$$

Since $(D/Dt)d\mathbf{x} = (\nabla\mathbf{v})d\mathbf{x}$ [see Eq. (3.12.6)],

$$\frac{D^2(ds)^2}{Dt^2} = d\mathbf{x} \cdot (\nabla\mathbf{v})^T \mathbf{A}_1 d\mathbf{x} + d\mathbf{x} \cdot \frac{D\mathbf{A}_1}{Dt} d\mathbf{x} + d\mathbf{x} \cdot \mathbf{A}_1 (\nabla\mathbf{v})d\mathbf{x}.$$

Comparing this last equation with the second equation in Eqs. (8.11.7), we have

$$\mathbf{A}_2 = \frac{D\mathbf{A}_1}{Dt} + \mathbf{A}_1 (\nabla\mathbf{v}) + (\nabla\mathbf{v})^T \mathbf{A}_1. \quad (8.11.9)$$

Equation (8.11.3) can be similarly derived (see Prob. 8.21).

Example 8.11.1

Using Eqs. (8.11.8) and (8.11.9) to obtain the first two Rivlin-Ericksen tensors for the velocity field here in spherical coordinates:

$$v_r = -\frac{a}{r^2}, \quad v_\theta = 0, \quad v_\phi = 0. \quad (8.11.10)$$

Solution

Using the equations provided in Chapter 2 for spherical coordinates, we obtain

$$[\nabla\mathbf{v}] = \begin{bmatrix} 2a/r^3 & 0 & 0 \\ 0 & -a/r^3 & 0 \\ 0 & 0 & -a/r^3 \end{bmatrix} \quad (8.11.11)$$

and

$$[\mathbf{A}_1] = [\nabla\mathbf{v}] + [\nabla\mathbf{v}]^T = \begin{bmatrix} 4a/r^3 & 0 & 0 \\ 0 & -2a/r^3 & 0 \\ 0 & 0 & -2a/r^3 \end{bmatrix}. \quad (8.11.12)$$

To use Eq. (8.11.9), we need to obtain $D\mathbf{A}_1/Dt = \partial\mathbf{A}_1/\partial t + (\nabla\mathbf{A}_1)\mathbf{v}$, where $(\nabla\mathbf{A}_1)$ is a third-order tensor. Since $\partial\mathbf{A}_1/\partial t = 0$ and $v_\theta = v_\phi = 0$,

$$(D\mathbf{A}_1/Dt)_{rr} = (\nabla\mathbf{A}_1)_{rrr} v_r,$$

$$(D\mathbf{A}_1/Dt)_{r\theta} = (\nabla\mathbf{A}_1)_{r\theta r} v_r,$$

$$(D\mathbf{A}_1/Dt)_{\theta\theta} = (\nabla\mathbf{A}_1)_{\theta\theta r} v_r, \text{ etc.}$$

Now, from Appendix 8.1, we obtain

$$(\nabla\mathbf{A}_1)_{rrr} = \frac{\partial(\mathbf{A}_1)_{rr}}{\partial r} = \left[\frac{\partial}{\partial r} \left(\frac{4a}{r^3} \right) \right] = -\frac{12a}{r^4},$$

$$(\nabla\mathbf{A}_1)_{\theta\theta\theta} = \frac{\partial(\mathbf{A}_1)_{\theta\theta}}{\partial r} = \left[\frac{\partial}{\partial r} \left(-\frac{2a}{r^3} \right) \right] = \frac{6a}{r^4},$$

$$(\nabla\mathbf{A}_1)_{\phi\phi\phi} = \frac{\partial(\mathbf{A}_1)_{\phi\phi}}{\partial r} = \left[\frac{\partial}{\partial r} \left(-\frac{2a}{r^3} \right) \right] = \frac{6a}{r^4},$$

$$(\nabla\mathbf{A}_1)_{r\theta r} = \frac{\partial(\mathbf{A}_1)_{r\theta}}{\partial r} = 0,$$

$$(\nabla\mathbf{A}_1)_{r\phi r} = (\nabla\mathbf{A}_1)_{\theta rr} = (\nabla\mathbf{A}_1)_{\theta\phi r} = (\nabla\mathbf{A}_1)_{\phi rr} = (\nabla\mathbf{A}_1)_{\phi\theta r} = 0.$$

Thus, $[D\mathbf{A}_1/Dt]$ is diagonal, with diagonal elements given by

$$\left(\frac{D\mathbf{A}_1}{Dt} \right)_{rr} = (\nabla\mathbf{A}_1)_{rrr} v_r = \left(-\frac{12a}{r^4} \right) \left(-\frac{a}{r^2} \right) = \frac{12a^2}{r^6}, \quad (8.11.13)$$

$$\left(\frac{D\mathbf{A}_1}{Dt} \right)_{\theta\theta} = (\nabla\mathbf{A}_1)_{\theta\theta r} v_r = \left(\frac{6a}{r^4} \right) \left(-\frac{a}{r^2} \right) = -\frac{6a^2}{r^6} = \left(\frac{D\mathbf{A}_1}{Dt} \right)_{\phi\phi}. \quad (8.11.14)$$

Since both \mathbf{A}_1 and $\nabla\mathbf{v}$ are diagonal, $\mathbf{A}_1(\nabla\mathbf{v}) + (\nabla\mathbf{v})^T\mathbf{A}_1$ is also diagonal and is equal to $2\mathbf{A}_1(\nabla\mathbf{v})$ with diagonal elements given by

$$[2\mathbf{A}_1(\nabla\mathbf{v})]_{rr} = \frac{16a^2}{r^6}, \quad [2\mathbf{A}_1(\nabla\mathbf{v})]_{\theta\theta} = [2\mathbf{A}_1(\nabla\mathbf{v})]_{\phi\phi} = \frac{4a^2}{r^6}. \quad (8.11.15)$$

Thus,

$$[\mathbf{A}_2] = \begin{bmatrix} \frac{12a^2}{r^6} & 0 & 0 \\ 0 & -\frac{6a^2}{r^6} & 0 \\ 0 & 0 & -\frac{6a^2}{r^6} \end{bmatrix} + \begin{bmatrix} \frac{16a^2}{r^6} & 0 & 0 \\ 0 & \frac{4a^2}{r^6} & 0 \\ 0 & 0 & -\frac{4a^2}{r^6} \end{bmatrix} = \begin{bmatrix} \frac{28a^2}{r^6} & 0 & 0 \\ 0 & -\frac{2a^2}{r^6} & 0 \\ 0 & 0 & -\frac{2a^2}{r^6} \end{bmatrix}. \quad (8.11.16)$$

These are the same results as those obtained in an example in the previous section using Eq. (8.10.2).

8.12 RELATION BETWEEN VELOCITY GRADIENT AND DEFORMATION GRADIENT

From

$$d\mathbf{x}'(\tau) = \mathbf{x}'_t(\mathbf{x} + d\mathbf{x}, \tau) - \mathbf{x}'_t(\mathbf{x}, \tau) = \mathbf{F}_t(\mathbf{x}, \tau)d\mathbf{x}, \quad (8.12.1)$$

we have

$$\frac{D}{D\tau}d\mathbf{x}' = \mathbf{v}'(\mathbf{x} + d\mathbf{x}, \tau) - \mathbf{v}'(\mathbf{x}, \tau) \equiv (\nabla_{\mathbf{x}}\mathbf{v}')d\mathbf{x} = \frac{D\mathbf{F}_t}{D\tau}d\mathbf{x}.$$

Thus,

$$\frac{D\mathbf{F}_t}{D\tau} = \nabla_{\mathbf{x}}\mathbf{v}'(\mathbf{x}, \tau), \quad (8.12.2)$$

from which we have

$$\frac{D\mathbf{F}_t}{Dt} = \nabla_{\mathbf{x}}\mathbf{v}(\mathbf{x}, t). \quad (8.12.3)$$

Using this relation, we can obtain the following relations between the rate of deformation tensor \mathbf{D} and the relative stretch tensor \mathbf{U}_t , as well as the relation between the spin tensor \mathbf{W} and the relative rotation tensor \mathbf{R}_t . In fact, from the polar decomposition theorem

$$\mathbf{F}_t(\mathbf{x}, \tau) = \mathbf{R}_t(\mathbf{x}, \tau)\mathbf{U}_t(\mathbf{x}, \tau), \quad (8.12.4)$$

we have

$$\frac{D\mathbf{F}_t(\mathbf{x}, \tau)}{D\tau} = \frac{D\mathbf{R}_t(\mathbf{x}, \tau)}{D\tau}\mathbf{U}_t(\mathbf{x}, \tau) + \mathbf{R}_t(\mathbf{x}, \tau)\frac{D\mathbf{U}_t(\mathbf{x}, \tau)}{D\tau}. \quad (8.12.5)$$

Evaluating the preceding equation at $\tau = t$ and using Eq. (8.12.3) [note also that $\mathbf{U}_t(\mathbf{x}, t) = \mathbf{R}_t(\mathbf{x}, t) = \mathbf{I}$], we obtain

$$\nabla_{\mathbf{x}}\mathbf{v}(\mathbf{x}, t) = \left[\frac{D\mathbf{R}_t}{D\tau} \right]_{\tau=t} + \left[\frac{D\mathbf{U}_t}{D\tau} \right]_{\tau=t}, \quad (8.12.6)$$

where on right-hand side, the first term is antisymmetric and the second term is symmetric. Now, since $\nabla_{\mathbf{x}}\mathbf{v}(\mathbf{x}, t) = \mathbf{D} + \mathbf{W}$ and the decomposition is unique (see Chapter 3),

$$\mathbf{W} = \left[\frac{D\mathbf{R}_t}{D\tau} \right]_{\tau=t}, \quad \mathbf{D} = \left[\frac{D\mathbf{U}_t}{D\tau} \right]_{\tau=t}. \quad (8.12.7)$$

8.13 TRANSFORMATION LAW FOR THE RELATIVE DEFORMATION TENSORS UNDER A CHANGE OF FRAME

The concept of objectivity was discussed in Chapter 5, Section 5.56. We recall that a change of frame, from \mathbf{x} to \mathbf{x}^* , is defined by the transformation

$$\mathbf{x}^* = \mathbf{c}(t) + \mathbf{Q}(t)(\mathbf{x} - \mathbf{x}_0), \quad (8.13.1)$$

and if a tensor \mathbf{A} , in the unstarred frame, transforms to \mathbf{A}^* in the starred frame in accordance with the relation

$$\mathbf{A}^* = \mathbf{Q}(t)\mathbf{A}\mathbf{Q}^T(t), \quad (8.13.2)$$

then the tensor \mathbf{A} is said to be objective, or frame indifferent (i.e., independent of observers).

From Eq. (8.13.1), we have [recall $\mathbf{x}' = \mathbf{x}'(\mathbf{x}, \tau)$]

$$d\mathbf{x}^*(t) = \mathbf{Q}(t)d\mathbf{x}, \quad d\mathbf{x}^*(\tau) = \mathbf{Q}(\tau)d\mathbf{x}'(\tau). \quad (8.13.3)$$

Since [see Eq. (8.12.1)]

$$d\mathbf{x}'(\tau) = \mathbf{F}_t(\mathbf{x}, \tau)d\mathbf{x} \quad \text{and} \quad d\mathbf{x}^*(\tau) = \mathbf{F}_t^*(\mathbf{x}^*, \tau^*)d\mathbf{x}^*, \quad (8.13.4)$$

from Eqs. (8.13.3) and (8.13.4), we have

$$\mathbf{F}_t^*(\mathbf{x}^*, \tau^*)d\mathbf{x}^*(t) = \mathbf{Q}(t)\mathbf{F}_t(\mathbf{x}, \tau)d\mathbf{x}. \quad (8.13.5)$$

Now the first equation of Eq. (8.13.3) gives $d\mathbf{x} = \mathbf{Q}^T(t)d\mathbf{x}^*(t)$; therefore Eq. (8.13.5) becomes

$$\mathbf{F}_t^*(\mathbf{x}^*, \tau^*) = \mathbf{Q}(t)\mathbf{F}_t(\mathbf{x}, \tau)\mathbf{Q}^T(t). \quad (8.13.6)$$

This is the *transformation law for $\mathbf{F}_t(\mathbf{x}, \tau)$ under a change of frame*. We see that $\mathbf{F}_t(\mathbf{x}, \tau)$ is not an objective tensor.

In the following, we agree that, for simplicity, we write

$$\mathbf{F}_t^* \equiv \mathbf{F}_t^*(\mathbf{x}^*, \tau^*), \mathbf{R}_t^* \equiv \mathbf{R}_t^*(\mathbf{x}^*, \tau^*), \mathbf{F}_t \equiv \mathbf{F}_t(\mathbf{x}, \tau), \mathbf{R}_t \equiv \mathbf{R}_t(\mathbf{x}, \tau), \text{ etc.} \quad (8.13.7)$$

Since $\mathbf{F}_t = \mathbf{R}_t\mathbf{U}_t$ and $\mathbf{F}_t^* = \mathbf{R}_t^*\mathbf{U}_t^*$; therefore, from Eq. (8.13.6), we have

$$\mathbf{R}_t^*\mathbf{U}_t^* = \mathbf{Q}(t)\mathbf{R}_t\mathbf{U}_t\mathbf{Q}^T(t).$$

We can write the preceding equation as

$$\mathbf{R}_t^*\mathbf{U}_t^* = [\mathbf{Q}(t)\mathbf{R}_t\mathbf{Q}^T(t)] [\mathbf{Q}(t)\mathbf{U}_t\mathbf{Q}^T(t)],$$

where $\mathbf{Q}(t)\mathbf{R}_t\mathbf{Q}^T(t)$ is orthogonal and $\mathbf{Q}(t)\mathbf{U}_t\mathbf{Q}^T(t)$ is symmetric; therefore, by the uniqueness of the polar decomposition, we can conclude that

$$\mathbf{R}_t^* = \mathbf{Q}(t)\mathbf{R}_t\mathbf{Q}^T(t) \quad (8.13.8)$$

and

$$\mathbf{U}_t^* = \mathbf{Q}(t)\mathbf{U}_t\mathbf{Q}^T(t). \quad (8.13.9)$$

Now, from $\mathbf{C}_t = \mathbf{U}_t\mathbf{U}_t$ and $\mathbf{C}_t^* = \mathbf{U}_t^*\mathbf{U}_t^*$, we easily obtain

$$\mathbf{C}_t^* = \mathbf{Q}(t)\mathbf{C}_t\mathbf{Q}^T(t), \quad (8.13.10)$$

and

$$\mathbf{C}_t^{*-1} = \mathbf{Q}(t)\mathbf{C}_t^{-1}\mathbf{Q}^T(t). \quad (8.13.11)$$

Similarly, we can obtain (see Prob. 8.24)

$$\mathbf{V}_t^* = \mathbf{Q}(t)\mathbf{V}_t\mathbf{Q}^T(t), \quad \mathbf{B}_t^* = \mathbf{Q}(t)\mathbf{B}_t\mathbf{Q}^T(t), \quad \mathbf{B}_t^{*-1} = \mathbf{Q}(t)\mathbf{B}_t^{-1}\mathbf{Q}^T(t). \quad (8.13.12)$$

Equations (8.13.9), (8.13.10), and (8.13.11) show that the right relative stretch tensor \mathbf{U}_t , the right relative Cauchy-Green tensor \mathbf{C}_t , and its inverse \mathbf{C}_t^{-1} are all objective tensors, whereas Eqs. (8.13.12) show that \mathbf{V}_t ,

\mathbf{B}_t and \mathbf{B}_t^{-1} are nonobjective. We note that this situation is different from that of the deformation tensors using a fixed reference configuration (see Section 5.56).

From Eqs. (8.12.7) and (8.13.8), we have [note: $D/D\tau^* = D/D\tau$]

$$\mathbf{W}^* = \left[\frac{D\mathbf{R}_t^*}{D\tau} \right]_{\tau=t} = \left[\left\{ \frac{d\mathbf{Q}(\tau)}{d\tau} \right\} \mathbf{R}_t(\tau) \mathbf{Q}^T(t) \right]_{\tau=t} + \left[\mathbf{Q}(\tau) \left\{ \frac{D\mathbf{R}_t}{D\tau} \right\} \mathbf{Q}^T(t) \right]_{\tau=t}.$$

Since $\mathbf{R}_t(t) = \mathbf{I}$ and $\frac{D\mathbf{R}_t}{Dt} = \mathbf{W}$; therefore,

$$\mathbf{W}^* = (d\mathbf{Q}/dt)\mathbf{Q}^T(t) + \mathbf{Q}(t)\mathbf{W}\mathbf{Q}^T(t), \quad (8.13.13)$$

which shows, as expected, that the spin tensor is not objective.

Using Eq. (8.13.13), we can show that for any objective tensor \mathbf{T} , the following tensor

$$\mathbf{S} \equiv \frac{D\mathbf{T}}{Dt} + \mathbf{T}\mathbf{W} - \mathbf{W}\mathbf{T}, \quad (8.13.14)$$

is an objective tensor (see Prob. 8.22). That is,

$$\mathbf{S}^* = \mathbf{Q}(t)\mathbf{S}\mathbf{Q}^T(t). \quad (8.13.15)$$

Example 8.13.1

The transformation law for $\nabla_{\mathbf{x}}\mathbf{v}$ in a change of frame was obtained in Chapter 5, Section 5.56, as [Eq. (5.56.20)]:

$$\nabla^*\mathbf{v}^* = \mathbf{Q}(t)(\nabla\mathbf{v})\mathbf{Q}^T(t) + (d\mathbf{Q}/dt)\mathbf{Q}^T. \quad (8.13.16)$$

Use Eq. (8.13.16) to obtain the transformation law for the rate of deformation tensor \mathbf{D} and the spin tensor \mathbf{W} .

Solution

From $\nabla^*\mathbf{v}^* = \mathbf{Q}(t)(\nabla\mathbf{v})\mathbf{Q}^T(t) + (d\mathbf{Q}/dt)\mathbf{Q}^T$, we have

$$(\nabla^*\mathbf{v}^*)^T = \mathbf{Q}(t)(\nabla\mathbf{v})^T\mathbf{Q}^T(t) + \mathbf{Q}(d\mathbf{Q}/dt)^T.$$

Therefore,

$$2\mathbf{D}^* = \nabla^*\mathbf{v}^* + (\nabla^*\mathbf{v}^*)^T = \mathbf{Q}(t)\left\{(\nabla\mathbf{v}) + (\nabla\mathbf{v})^T\right\}\mathbf{Q}^T(t) + (d\mathbf{Q}/dt)\mathbf{Q}^T + \mathbf{Q}(d\mathbf{Q}/dt)^T.$$

But

$$(d\mathbf{Q}/dt)\mathbf{Q}^T + \mathbf{Q}(d\mathbf{Q}/dt)^T = (d/dt)(\mathbf{Q}\mathbf{Q}^T) = (d/dt)(\mathbf{I}) = 0. \quad (8.13.17)$$

Therefore,

$$\mathbf{D}^* = \mathbf{Q}(t)\mathbf{D}\mathbf{Q}^T(t). \quad (8.13.18)$$

That is, the rate of deformation tensor \mathbf{D} is objective. Next,

$$2\mathbf{W}^* = \nabla^*\mathbf{v}^* - (\nabla^*\mathbf{v}^*)^T = \mathbf{Q}(t)\left\{(\nabla\mathbf{v}) - (\nabla\mathbf{v})^T\right\}\mathbf{Q}^T(t) + (d\mathbf{Q}/dt)\mathbf{Q}^T - \mathbf{Q}(d\mathbf{Q}/dt)^T.$$

But, from Eq. (8.13.17), $\mathbf{Q}(d\mathbf{Q}/dt)^T = -(d\mathbf{Q}/dt)\mathbf{Q}^T$, therefore,

$$\mathbf{W}^* = \mathbf{Q}(t)\mathbf{W}\mathbf{Q}^T(t) + (d\mathbf{Q}/dt)\mathbf{Q}^T. \quad (8.13.19)$$

This is the same as Eq. (8.13.13).

8.14 TRANSFORMATION LAW FOR RIVLIN-ERICKSEN TENSORS UNDER A CHANGE OF FRAME

From Eq. (8.13.10),

$$\mathbf{C}_t^*(\tau) = \mathbf{Q}(t)\mathbf{C}_t(\tau)\mathbf{Q}^T(t), \quad (8.14.1)$$

we obtain (*note: $D/D\tau^* = D/D\tau$*),

$$\frac{D\mathbf{C}_t^*(\tau)}{D\tau^*} = \mathbf{Q}(t)\frac{D\mathbf{C}_t(\tau)}{D\tau}\mathbf{Q}^T(t), \quad (8.14.2)$$

and

$$\frac{D^N\mathbf{C}_t^*(\tau)}{D\tau^{*N}} = \mathbf{Q}(t)\frac{D^N\mathbf{C}_t(\tau)}{D\tau^N}\mathbf{Q}^T(t). \quad (8.14.3)$$

Thus [see Eq. (8.10.2)],

$$\mathbf{A}_N^*(t) = \mathbf{Q}(t)\mathbf{A}_N(t)\mathbf{Q}^T(t). \quad (8.14.4)$$

We see, therefore, that all \mathbf{A}_N ($N = 1, 2, \dots$) are objective. This is quite to be expected because these tensors characterize the rate and the higher rates of changes of length of material elements which are independent of the observers.

8.15 INCOMPRESSIBLE SIMPLE FLUID

An incompressible simple fluid is an isotropic ideal material with the following constitutive equation

$$\mathbf{T} = -p\mathbf{I} + \mathbf{S}, \quad (8.15.1)$$

where \mathbf{S} depends on the past histories up to the current time t of the relative deformation tensor \mathbf{C}_t . In other words, a simple fluid is defined by

$$\mathbf{T} = -p\mathbf{I} + \mathbf{H}[\mathbf{C}_t(\mathbf{x}, \tau); -\infty < \tau \leq t], \quad (8.15.2)$$

where $-\infty < \tau \leq t$ indicates that the values of the functional \mathbf{H} depends on all \mathbf{C}_t from $\mathbf{C}_t(\mathbf{x}, -\infty)$ to $\mathbf{C}_t(\mathbf{x}, t)$. We note that such a fluid is called “**simple**” because it depends only on the history of the relative deformation gradient $\mathbf{F}_t(\mathbf{x}, \tau)$ [from which $\mathbf{C}_t(\mathbf{x}, \tau)$ is obtained] and not on the histories of the relative higher deformation gradients [e.g., $\nabla\mathbf{F}_t(\mathbf{x}, \tau)$, $\nabla\nabla\mathbf{F}_t(\mathbf{x}, \tau)$ and so on].

Obviously, the functional \mathbf{H} in Eq. (8.15.2) is to be the same for all observers (i.e., $\mathbf{H}^* = \mathbf{H}$). However, it cannot be arbitrary, because it must satisfy the frame indifference requirement. That is, in a change of frame,

$$\mathbf{H}[\mathbf{C}_t^*(\mathbf{x}^*, \tau^*)] = \mathbf{Q}(t)\mathbf{H}[\mathbf{C}_t(\mathbf{x}, \tau)]\mathbf{Q}^T(t). \quad (8.15.3)$$

Since $\mathbf{C}_t(\mathbf{x}, \tau)$ transforms in a change of frame as

$$\mathbf{C}_t^*(\mathbf{x}^*, \tau^*) = \mathbf{Q}(t)\mathbf{C}_t(\mathbf{x}, \tau)\mathbf{Q}^T(t). \quad (8.15.4)$$

Therefore, the functional $\mathbf{H}[\mathbf{C}_t(\mathbf{x}, \tau); -\infty < \tau \leq t]$ must satisfy the condition

$$\mathbf{H}[\mathbf{Q}(t)\mathbf{C}_t\mathbf{Q}^T(t)] = \mathbf{Q}(t)\mathbf{H}[\mathbf{C}_t]\mathbf{Q}^T(t). \quad (8.15.5)$$

We note that Eq. (8.15.5) also states that the fluid defined by Eq. (8.15.2) is an isotropic fluid.

Any function or functional that obeys the condition given by Eq. (8.15.5) is known as an *isotropic function* or *isotropic functional*.

The relationship between stress and deformation, given by Eq. (8.15.2), is completely general. In fact, it includes Newtonian incompressible fluid and Maxwell fluids as special cases. In Part C of this chapter, we consider a special class of flow, called *viscometric flow*, using this general form of constitutive equation. First, however, we discuss some special constitutive equations, some of which have been shown to be approximations to the general constitutive equation given in Eq. (8.15.2) under certain conditions such as slow flow and/or fading memory. They can also be considered simply as special fluids. For example, a Newtonian incompressible fluid can be considered either as a special fluid by itself or as an approximation to the general simple fluid when it has no memory of its past history of deformation and is under slow-flow condition relative to its relaxation time (which is zero).

8.16 SPECIAL SINGLE INTEGRAL-TYPE NONLINEAR CONSTITUTIVE EQUATIONS

In Section 8.4, we saw that the constitutive equation for the linear Maxwell fluid is defined by

$$\mathbf{S} = 2 \int_0^{\infty} f(s) \mathbf{E}(t-s) ds, \quad (8.16.1)$$

where \mathbf{E} is the infinitesimal strain tensor measured with respect to the configuration at time t . It can be shown that for small deformations (see Example 8.16.2),

$$\mathbf{C}_t - \mathbf{I} = \mathbf{I} - \mathbf{C}_t^{-1} = 2\mathbf{E}. \quad (8.16.2)$$

Thus, the following two nonlinear viscoelastic fluids represent natural generalizations of the linear Maxwell fluid in that they reduce to Eq. (8.16.1) under small deformation conditions:

$$\mathbf{S} = \int_0^{\infty} f_1(s) [\mathbf{C}_t(t-s) - \mathbf{I}] ds, \quad (8.16.3)$$

and

$$\mathbf{S} = \int_0^{\infty} f_2(s) [\mathbf{I} - \mathbf{C}_t^{-1}(t-s)] ds, \quad (8.16.4)$$

where the memory function $f_i(s)$ may be given by any one of Eqs. (8.4.9), (8.4.10), or (8.4.11).

We note that since $\mathbf{C}_t(\tau)$ is an objective tensor; therefore, the constitutive equations defined by Eq. (8.16.3) and Eq. (8.16.4) are frame indifferent (that is, independent of observers). We note also that if $f_1 = f_2$ in Eq. (8.16.3) and Eq. (8.16.4), then they describe the same behaviors at small deformation. But they are two different nonlinear viscoelastic fluids, behaving differently at large deformation, even with $f_1 = f_2$. Furthermore, if we treat $f_1(s)$ and $f_2(s)$ as two different memory functions, Eq. (8.16.3) and Eq. (8.16.4) define two nonlinear viscoelastic fluids whose behavior at small deformation are also different.

Example 8.16.1

For the nonlinear viscoelastic fluid defined by Eq. (8.16.3), find the stress components when the fluid is under steady shearing flow defined by the velocity field:

$$v_1 = kx_2, \quad v_2 = v_3 = 0. \quad (i)$$

Solution

The relative Cauchy-Green deformation tensor corresponding to this flow was obtained in Example 8.9.1 as

$$[\mathbf{C}_t] = \begin{bmatrix} 1 & k(\tau - t) & 0 \\ k(\tau - t) & k^2(\tau - t)^2 + 1 & 0 \\ 0 & 0 & 1 \end{bmatrix}. \quad (\text{ii})$$

Thus,

$$[\mathbf{C}_t(t - s) - \mathbf{I}] = \begin{bmatrix} 0 & -ks & 0 \\ -ks & k^2s^2 & 0 \\ 0 & 0 & 0 \end{bmatrix}. \quad (\text{iii})$$

From Eq. (8.16.3),

$$S_{11} = S_{13} = S_{23} = S_{33} = 0, \quad (\text{iv})$$

$$S_{12} = -k \int_0^\infty sf_1(s)ds, \quad S_{22} = k^2 \int_0^\infty s^2f_1(s)ds. \quad (\text{v})$$

We see that for this fluid, the viscosity is given by

$$\mu = S_{12}/k = - \int_0^\infty sf_1(s)ds. \quad (\text{vi})$$

We also note that the normal stresses are not equal in the simple shearing flow. In fact,

$$T_{11} = -p + S_{11} = -p, \quad T_{22} = -p + S_{22} = -p + k^2 \int_0^\infty s^2f_1(s)ds, \quad T_{33} = -p + S_{33} = -p. \quad (\text{vii})$$

We see from the preceding example that for the nonlinear viscoelastic fluid defined by

$$\mathbf{S} = \int_0^\infty f_1(s)[\mathbf{C}_t(t - s) - \mathbf{I}]ds,$$

the *shear stress function* $\tau(k)$ is given by

$$\tau(k) \equiv S_{12} = -k \int_0^\infty sf_1(s)ds, \quad (\text{8.16.5})$$

and the two *normal stress functions* are given by either

$$\sigma_1(k) \equiv S_{11} - S_{22} = -k^2 \int_0^\infty s^2f_1(s)ds, \quad \sigma_2(k) \equiv S_{22} - S_{33} = k^2 \int_0^\infty s^2f_1(s)ds \quad (\text{8.16.6})$$

or

$$\bar{\sigma}_1(k) \equiv S_{22} - S_{33} = k^2 \int_0^\infty s^2f_1(s)ds, \quad \bar{\sigma}_2(k) \equiv S_{11} - S_{33} = 0. \quad (\text{8.16.7})$$

The shear stress function $\tau(k)$ and the two normal stress functions (either σ_1 and σ_2 or $\bar{\sigma}_1$ and $\bar{\sigma}_2$) completely describe the material properties of this nonlinear viscoelastic fluid in the simple shearing flow.

In Part C, we will show that these three material functions completely describe the material properties of every simple fluid, of which the present nonlinear fluid is a special case in viscometric flow, of which the simple shearing flow is a special case. The function

$$\mu_{app} \equiv \tau(k)/k, \quad (8.16.8)$$

is known as the apparent viscosity function. Similarly, for the nonlinear viscoelastic fluid defined by Eq. (8.16.4), i.e.,

$$\mathbf{S} = \int_0^\infty f_2(s) [\mathbf{I} - \mathbf{C}_t^{-1}(t-s)] ds, \quad (8.16.9)$$

the shear stress function and the two normal stress functions can be obtained to be (see Prob. 8.23)

$$S_{12}(k) = -k \int_0^\infty s f_2(s) ds, \quad \sigma_1(k) = -k^2 \int_0^\infty s^2 f_2(s) ds, \quad \sigma_2(k) = 0. \quad (8.16.10)$$

A special nonlinear viscoelastic fluid defined by Eq. (8.16.4) with a memory function dependent on the second invariant I_2 of the tensor \mathbf{C}_t in the following way:

$$f_2(s) = f(s) = -\frac{\mu}{\lambda^2} e^{-s/\lambda} \quad \text{when } I_2 \geq B^2 + 3 \quad \text{and} \quad f_2(s) = 0 \quad \text{when } I_2 < B^2 + 3 \quad (8.16.11)$$

is known as the *Tanner and Simmons network model fluid*. For this model, the network “breaks” when a scalar measure of the deformation I_2 reaches a limiting value of $B^2 + 3$, where B is called the *strength* of the network.

Example 8.16.2

Show that for small deformation relative to the configuration at the current time t

$$\mathbf{C}_t - \mathbf{I} \approx \mathbf{I} - \mathbf{C}_t^{-1} \approx 2\mathbf{E}, \quad (8.16.12)$$

where \mathbf{E} is the infinitesimal strain tensor.

Solution

Let \mathbf{u} denote the displacement vector measured from the configuration at time t . Then

$$\mathbf{x}'(\tau) = \mathbf{x} + \mathbf{u}(\mathbf{x}, \tau).$$

Thus,

$$\mathbf{F}_t = \nabla \mathbf{x}' = \mathbf{I} + \nabla \mathbf{u}.$$

If \mathbf{u} is infinitesimal, then

$$\mathbf{C}_t = \mathbf{F}_t^T \mathbf{F}_t = [\mathbf{I} + (\nabla \mathbf{u})^T][\mathbf{I} + (\nabla \mathbf{u})] \approx \mathbf{I} + 2\mathbf{E}, \quad \mathbf{E} = [\nabla \mathbf{u} + (\nabla \mathbf{u})^T]/2,$$

and

$$\mathbf{C}_t^{-1} \approx (\mathbf{I} + 2\mathbf{E})^{-1} \approx \mathbf{I} - 2\mathbf{E}.$$

Thus, for small deformation,

$$\mathbf{C}_t - \mathbf{I} \approx 2\mathbf{E} \quad \text{and} \quad \mathbf{I} - \mathbf{C}_t^{-1} \approx 2\mathbf{E}.$$

Example 8.16.3

Show that any polynomial function of a real symmetric tensor \mathbf{A} can be represented by

$$\mathbf{F}(\mathbf{A}) = f_0 \mathbf{I} + f_1 \mathbf{A} + f_2 \mathbf{A}^{-1}, \quad (8.16.13)$$

where f_i are real valued functions of the scalar invariants of the symmetric tensor \mathbf{A} .

Solution

Let

$$\mathbf{F}(\mathbf{A}) = a_0 \mathbf{I} + a_1 \mathbf{A} + a_2 \mathbf{A}^2 + \dots + a_N \mathbf{A}^N. \quad (8.16.14)$$

Since \mathbf{A} satisfies its own characteristic equation:

$$\mathbf{A}^3 - I_1 \mathbf{A}^2 + I_2 \mathbf{A} - I_3 \mathbf{I} = \mathbf{0}, \quad (8.16.15)$$

therefore,

$$\begin{aligned} \mathbf{A}^3 &= I_1 \mathbf{A}^2 - I_2 \mathbf{A} + I_3 \mathbf{I}, \\ \mathbf{A}^4 &= I_1 \mathbf{A}^3 - I_2 \mathbf{A}^2 - I_3 \mathbf{A} = I_1(I_1 \mathbf{A}^2 - I_2 \mathbf{A} - I_3) - I_2 \mathbf{A}^2 - I_3 \mathbf{A}, \text{ etc.} \end{aligned} \quad (8.16.16)$$

Thus, every \mathbf{A}^N for $N \geq 3$ can be expressed as a sum of \mathbf{A} , \mathbf{A}^2 , and \mathbf{I} with coefficients being functions of the scalar invariants of \mathbf{A} . Substituting these expressions in Eq. (8.16.14), one obtains

$$\mathbf{F}(\mathbf{A}) = b_0(I_i) \mathbf{I} + b_1(I_i) \mathbf{A} + b_2(I_i) \mathbf{A}^2. \quad (8.16.17)$$

Now, from Eq. (8.16.15),

$$\mathbf{A}^2 = I_1 \mathbf{A} - I_2 \mathbf{I} + I_3 \mathbf{A}^{-1}, \quad (8.16.18)$$

therefore, Eq. (8.16.17) can be written as

$$\mathbf{F}(\mathbf{A}) = f_0(I_i) \mathbf{I} + f_1(I_i) \mathbf{A} + f_2(I_i) \mathbf{A}^{-1}. \quad (8.16.19)$$

In the preceding example, we have shown that if $\mathbf{F}(\mathbf{A})$ is given by a polynomial, Eq. (8.16.14), then it can be represented by Eq. (8.16.19). More generally, it was shown in Appendix 5C.1 (the representation theorem of isotropic functions) of Chapter 5 that every isotropic function $\mathbf{F}(\mathbf{A})$ of a symmetric tensor \mathbf{A} can be represented by Eq. (8.16.17) and therefore by Eq. (8.16.19). Now, let us identify \mathbf{A} with \mathbf{C}_t and I_i with the scalar invariants of \mathbf{C}_t (note: however, $I_3 = 1$ for an incompressible fluid), then the most general representation of $\mathbf{F}(\mathbf{C}_t)$ (which must be an isotropic function in order to satisfy the condition for frame indifference) may be written:

$$\mathbf{F}(\mathbf{C}_t) = f_1(I_1, I_2) \mathbf{C}_t + f_2(I_1, I_2) \mathbf{C}_t^{-1}. \quad (8.16.20)$$

8.17 GENERAL SINGLE INTEGRAL-TYPE NONLINEAR CONSTITUTIVE EQUATIONS

From the discussion given in the end of the previous example (see also Appendix 5C.1 of Chapter 5), we see that the most general single integral-type nonlinear constitutive equation for an incompressible fluid is defined by

$$\mathbf{S} = \int_0^\infty [f_1(s, I_1, I_2) \mathbf{C}_t(t-s) + f_2(s, I_1, I_2) \mathbf{C}_t^{-1}(t-s)] ds, \quad (8.17.1)$$

where I_1 and I_2 are the first and second principal scalar invariants of $\mathbf{C}_t^{-1}(\tau)$.

A special nonlinear viscoelastic fluid, known as the BKZ fluid,[§] is defined by Eq. (8.17.1) with $f_1(s, I_1, I_2)$ and $f_2(s, I_1, I_2)$ given by:

$$f_1(s, I_1, I_2) = -2 \frac{\partial U}{\partial I_2} \quad \text{and} \quad f_2(s, I_1, I_2) = 2 \frac{\partial U}{\partial I_1}, \quad (8.17.2)$$

where the function $U(I_1, I_2, s)$ is chosen as

$$-U = \frac{9}{2} \dot{\beta} \ln \frac{I_1 + I_2 + 3}{9} + 24(\dot{\beta} - \dot{c}) \ln \left(\frac{I_1 + 15}{I_2 + 15} \right) + \dot{c}(I_1 - 3), \quad (8.17.3)$$

with

$$\dot{\beta} \equiv \frac{d\beta(s)}{ds}, \quad \dot{c} \equiv \frac{dc(s)}{ds} \quad \text{and} \quad \beta(s) + c(s) = \phi(s)/2. \quad (8.17.4)$$

where $\phi(s)$ is the relaxation function. The function $c(s)$ will be seen to be related to the viscosity at very large rate of shear.

For simple shearing flow, with $v_1 = kx_2$, $v_2 = v_3 = 0$ and $\tau \equiv t - s$, we have

$$[\mathbf{C}_t] = \begin{bmatrix} 1 & -ks & 0 \\ -ks & k^2s^2 + 1 & 0 \\ 0 & 0 & 1 \end{bmatrix}, \quad [\mathbf{C}_t^{-1}] = \begin{bmatrix} k^2s^2 + 1 & ks & 0 \\ ks & 1 & 0 \\ 0 & 0 & 1 \end{bmatrix}, \quad (8.17.5)$$

and

$$I_1 = k^2s^2 + 3, \quad I_2 = \left| \begin{array}{cc} k^2s^2 + 1 & ks \\ ks & 1 \end{array} \right| + \left| \begin{array}{cc} k^2s^2 + 1 & 0 \\ 0 & 1 \end{array} \right| + \left| \begin{array}{cc} 1 & 0 \\ 0 & 1 \end{array} \right| = 3 + k^2s^2. \quad (8.17.6)$$

Thus,

$$I_1 + I_2 + 3 = 9 + 2k^2s^2, \quad I_1 + 15 = k^2s^2 + 18 = I_2 + 15, \quad (8.17.7)$$

so that

$$\phi_1 = -2 \frac{\partial U}{\partial II} = \frac{9\dot{\beta}}{9 + 2k^2s^2} - \frac{48(\dot{\beta} - \dot{c})}{k^2s^2 + 18}, \quad \phi_2 = 2 \frac{\partial U}{\partial I} = -\frac{9\dot{\beta}}{9 + 2k^2s^2} - \frac{48(\dot{\beta} - \dot{c})}{k^2s^2 + 18} - \dot{c}. \quad (8.17.8)$$

Now, from $\mathbf{S} = \int_0^\infty [\phi_1(s, I, II)\mathbf{C}_t + \phi_2(s, I, II)\mathbf{C}_t^{-1}]ds$ and $(C_t)_{12} = -ks$ and $(C_t^{-1})_{12} = ks$, we obtain the shear stress function and the apparent viscosity as

$$S_{12} = -2k \int_0^\infty \left[\frac{9\dot{\beta}s}{9 + 2k^2s^2} + \dot{c}s \right] ds, \quad \mu_{app} = \frac{S_{12}}{k} = -2 \int_0^\infty \left[\frac{9\dot{\beta}s}{9 + 2k^2s^2} + \dot{c}s \right] ds. \quad (8.17.9)$$

At a very large rate of shear, $k \rightarrow \infty$, the viscosity is

$$\mu_\infty = -2 \int_0^\infty \dot{c}(s)s ds = -2 \int_0^\infty \frac{dc}{ds} s ds = -2 \left[cs \Big|_0^\infty - \int_0^\infty cds \right] = 2 \int_0^\infty cds. \quad (8.17.10)$$

[§]Bernstein, B., E. A. Kearsley, and L. J. Zappas, *Trans. Soc. of Rheology*, Vol. VII, 1963, p. 391.

Example 8.17.1

For synovial fluids, the viscosity at a large rate of shear k is much smaller than that at small k (as much as 10,000 times smaller has been measured); therefore, we can take $c(s) = 0$ so that $\beta(s) = \phi(s)/2$, where $\phi(s)$ is the relaxation function. (a) Show that for this case, the BKZ model gives the apparent viscosity as

$$\mu_{app} = \int_0^\infty H(\tau) \left\{ \int_0^\infty \frac{x e^{-x}}{(1 + (2/9)k^2 x^2 \tau^2)} dx \right\} d\tau, \tag{8.17.11}$$

where $H(\tau)$ is the relaxation spectrum, and (b) obtain the apparent viscosities for the three synovial fluids of Example 8.5.1.

Solution

(a) With $c(s) = 0$ and $\beta(s) = \phi(s)/2$, the second equation in Eq. (8.17.9) becomes

$$\mu_{app} = - \int_0^\infty \left[\frac{s}{1 + (2/9)k^2 s^2} \frac{d\phi}{ds} \right] ds. \tag{i}$$

With $\phi(s) = \int_{\tau=0}^\infty \frac{H(\tau)}{\tau} e^{-s/\tau} d\tau$, we have $d\phi/ds = \int_{\tau=0}^\infty \frac{H(\tau)}{\tau} e^{-s/\tau} \left(-\frac{1}{\tau} \right) d\tau$,

so that

$$\mu_{app} = \int_{s=0}^\infty \left[\int_{\tau=0}^\infty \frac{s}{1 + (2/9)k^2 s^2} \frac{H(\tau)}{\tau^2} e^{-\frac{s}{\tau}} d\tau \right] ds = \int_{\tau=0}^\infty \int_{s=0}^\infty \frac{s}{1 + (2/9)k^2 s^2} \frac{H(\tau)}{\tau^2} e^{-\frac{s}{\tau}} ds/d\tau. \tag{ii}$$

Next, let $x = s/\tau$, then $ds = \tau dx$; we arrive at Eq. (8.17.11).

(b) Using the relaxation spectra $H(\tau)$ obtained in Example 8.5.1 for the three synovial fluids, numerical integration of the above equation gives the apparent viscosities as shown in Figure 8.17-1.*

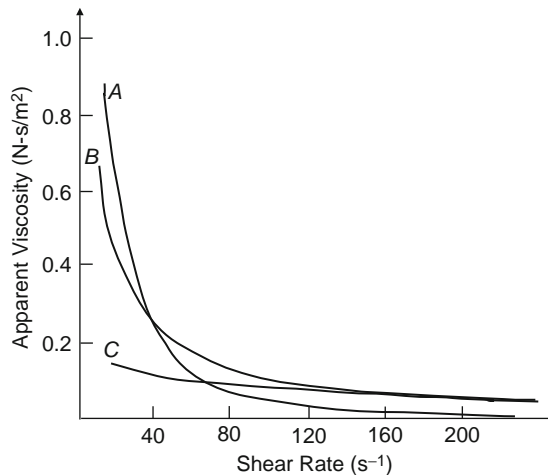

FIGURE 8.17-1 Calculated apparent viscosity as a function of rate of shear $k(s^{-1})$ for the three synovial fluids.

*Lai, Kuei, and Mow, loc. cit.

8.18 DIFFERENTIAL-TYPE CONSTITUTIVE EQUATIONS FOR INCOMPRESSIBLE FLUIDS

We saw in Section 8.10 that under the assumption that the Taylor series expansion of the history of the deformation tensor $\mathbf{C}_t(\mathbf{x}, \tau)$ is justified, the Rivlin-Ericksen tensor \mathbf{A}_N , ($N = 1, 2 \dots \infty$) determines the history of $\mathbf{C}_t(\mathbf{x}, \tau)$. Thus, we may write Eq. (8.15.2) as

$$\mathbf{T} = -p\mathbf{I} + \mathbf{f}(\mathbf{A}_1, \mathbf{A}_2 \dots \mathbf{A}_N \dots), \quad \text{tr}\mathbf{A}_1 = 0, \quad (8.18.1)$$

where $\mathbf{f}(\mathbf{A}_1, \mathbf{A}_2 \dots \mathbf{A}_N \dots)$ is a function of the Rivlin-Ericksen tensor and $\text{tr}\mathbf{A}_1 = 0$ follows from the equation of conservation of mass for an incompressible fluid.

To satisfy the frame-indifference condition, the function \mathbf{f} cannot be arbitrary but must satisfy the relation that for any orthogonal tensor \mathbf{Q} :

$$\mathbf{Q}\mathbf{f}(\mathbf{A}_1, \mathbf{A}_2 \dots \mathbf{A}_N \dots)\mathbf{Q}^T = \mathbf{f}(\mathbf{Q}\mathbf{A}_1\mathbf{Q}^T, \mathbf{Q}\mathbf{A}_2\mathbf{Q}^T \dots \mathbf{Q}\mathbf{A}_N\mathbf{Q}^T \dots). \quad (8.18.2)$$

We note, again, that Eq. (8.18.2) makes “isotropy of material property” a part of the definition of a simple fluid.

The following are special constitutive equations of this type.

A. Rivlin-Ericksen Incompressible Fluid of Complexity n

$$\mathbf{T} = -p\mathbf{I} + \mathbf{f}(\mathbf{A}_1, \mathbf{A}_2 \dots \mathbf{A}_N). \quad (8.18.3)$$

In particular, a Rivlin-Ericksen liquid of complexity 2 is given by

$$\begin{aligned} \mathbf{T} = & -p\mathbf{I} + \mu_1\mathbf{A}_1 + \mu_2\mathbf{A}_1^2 + \mu_3\mathbf{A}_2 + \mu_4\mathbf{A}_2^2 + \mu_5(\mathbf{A}_1\mathbf{A}_2 + \mathbf{A}_2\mathbf{A}_1) \\ & \mu_6(\mathbf{A}_1\mathbf{A}_2^2 + \mathbf{A}_2^2\mathbf{A}_1) + \mu_7(\mathbf{A}_1^2\mathbf{A}_2 + \mathbf{A}_2\mathbf{A}_1^2) + \mu_8(\mathbf{A}_1^2\mathbf{A}_2^2 + \mathbf{A}_2^2\mathbf{A}_1^2), \end{aligned} \quad (8.18.4)$$

where $\mu_1, \mu_2 \dots \mu_N$ are scalar material functions of the following scalar invariants:

$$\text{tr}\mathbf{A}_1^2, \text{tr}\mathbf{A}_1^3, \text{tr}\mathbf{A}_2, \text{tr}\mathbf{A}_2^2, \text{tr}\mathbf{A}_2^3, \text{tr}\mathbf{A}_1\mathbf{A}_2, \text{tr}\mathbf{A}_1\mathbf{A}_2^2, \text{tr}\mathbf{A}_2\mathbf{A}_1^2, \text{tr}\mathbf{A}_1^2\mathbf{A}_2^2. \quad (8.18.5)$$

We note that if $\mu_2 = \mu_3 = \dots \mu_N = 0$ and μ_1 is a constant, Eq. (8.18.4) reduces to the constitutive equation for a Newtonian liquid with viscosity μ_1 .

B. Second-Order Fluid

$$\mathbf{T} = -p\mathbf{I} + \mu_1\mathbf{A}_1 + \mu_2\mathbf{A}_1^2 + \mu_3\mathbf{A}_2, \quad (8.18.6)$$

where μ_1, μ_2 and μ_3 are material constants. The second-order fluid may be regarded as a special case of the Rivlin-Ericksen fluid. However, it has also been shown that under the assumption of fading memory, small deformation, and slow flow, Eq. (8.18.6) provides the second-order approximation, whereas the Newtonian fluid provides the first-order approximation and the inviscid fluid, the zeroth-order approximation for the simple fluid.

Example 8.18.1

For a second-order fluid, compute the stress components in a simple shearing flow given by the velocity field:

$$v_1 = kx_2, \quad v_2 = v_3 = 0. \quad (8.18.7)$$

Solution

From Example 8.10.1, we have for the simple shearing flow

$$[\mathbf{A}_1] = \begin{bmatrix} 0 & k & 0 \\ k & 0 & 0 \\ 0 & 0 & 0 \end{bmatrix}, \quad [\mathbf{A}_2] = \begin{bmatrix} 0 & 0 & 0 \\ 0 & 2k^2 & 0 \\ 0 & 0 & 0 \end{bmatrix}, \quad \mathbf{A}_N = \mathbf{0}, \quad N \geq 3. \quad (8.18.8)$$

Now

$$[\mathbf{A}_1^2] = \begin{bmatrix} 0 & k & 0 \\ k & 0 & 0 \\ 0 & 0 & 0 \end{bmatrix} \begin{bmatrix} 0 & k & 0 \\ k & 0 & 0 \\ 0 & 0 & 0 \end{bmatrix} = \begin{bmatrix} k^2 & 0 & 0 \\ 0 & k^2 & 0 \\ 0 & 0 & 0 \end{bmatrix}, \quad (8.18.9)$$

therefore, Eq. (8.18.6) gives

$$T_{11} = -\rho + \mu_2 k^2, \quad T_{22} = -\rho + \mu_2 k^2 + 2\mu_3 k^2, \quad T_{33} = -\rho, \quad T_{12} = \mu_1 k, \quad T_{13} = T_{23} = 0. \quad (8.18.10)$$

We see that because of the presence of μ_2 and μ_3 , normal stresses, in excess of p on the planes $x_1 = \text{constant}$ and $x_2 = \text{constant}$, are necessary to maintain the shearing flow. Furthermore, these normal stress components are not equal. The normal stress functions are given by

$$\sigma_1(k) \equiv T_{11} - T_{22} = -2\mu_3 k^2, \quad \sigma_2(k) \equiv T_{22} - T_{33} = \mu_2 k^2 + 2\mu_3 k^2. \quad (8.18.11)$$

By measuring the normal stress differences and the shearing stress components, the three material constants μ_1 , μ_2 and μ_3 can be determined.

Example 8.18.2

For the simple shearing flow, compute the stress components for a Rivlin-Ericksen liquid.

Solution

We note that for this flow, $\mathbf{A}_N = \mathbf{0}$ for $N \geq 3$; therefore, the stress is the same as that given by Eq. (8.18.4). We have

$$[\mathbf{A}_1] = \begin{bmatrix} 0 & k & 0 \\ k & 0 & 0 \\ 0 & 0 & 0 \end{bmatrix}, \quad [\mathbf{A}_2] = \begin{bmatrix} 0 & 0 & 0 \\ 0 & 2k^2 & 0 \\ 0 & 0 & 0 \end{bmatrix}, \quad [\mathbf{A}_1^2] = \begin{bmatrix} k^2 & 0 & 0 \\ 0 & k^2 & 0 \\ 0 & 0 & 0 \end{bmatrix}, \quad [\mathbf{A}_2^2] = \begin{bmatrix} 0 & 0 & 0 \\ 0 & 4k^4 & 0 \\ 0 & 0 & 0 \end{bmatrix},$$

$$[\mathbf{A}_1][\mathbf{A}_2] = \begin{bmatrix} 0 & 2k^3 & 0 \\ 0 & 0 & 0 \\ 0 & 0 & 0 \end{bmatrix}, \quad [\mathbf{A}_2][\mathbf{A}_1] = \begin{bmatrix} 0 & 0 & 0 \\ 2k^3 & 0 & 0 \\ 0 & 0 & 0 \end{bmatrix}, \quad [\mathbf{A}_1][\mathbf{A}_2^2] = \begin{bmatrix} 0 & 4k^5 & 0 \\ 0 & 0 & 0 \\ 0 & 0 & 0 \end{bmatrix},$$

$$[\mathbf{A}_2^2][\mathbf{A}_1] = \begin{bmatrix} 0 & 0 & 0 \\ 4k^5 & 0 & 0 \\ 0 & 0 & 0 \end{bmatrix}, \quad [\mathbf{A}_1^2][\mathbf{A}_2] = [\mathbf{A}_2][\mathbf{A}_1^2] = \begin{bmatrix} 0 & 0 & 0 \\ 0 & 2k^4 & 0 \\ 0 & 0 & 0 \end{bmatrix},$$

$$[\mathbf{A}_1^2][\mathbf{A}_2^2] = [\mathbf{A}_2^2][\mathbf{A}_1^2] = \begin{bmatrix} 0 & 0 & 0 \\ 0 & 4k^6 & 0 \\ 0 & 0 & 0 \end{bmatrix}, \quad [\mathbf{A}_1^3] = \begin{bmatrix} 0 & k^3 & 0 \\ k^3 & 0 & 0 \\ 0 & 0 & 0 \end{bmatrix}, \quad [\mathbf{A}_2^3] = \begin{bmatrix} 0 & 0 & 0 \\ 0 & 8k^6 & 0 \\ 0 & 0 & 0 \end{bmatrix},$$

and

$$\begin{aligned} \text{tr}\mathbf{A}_1^2 &= 2k^2, & \text{tr}\mathbf{A}_1^3 &= 0, & \text{tr}\mathbf{A}_2 &= 2k^2, & \text{tr}\mathbf{A}_2^2 &= 4k^4, & \text{tr}\mathbf{A}_2^3 &= 8k^6, \\ \text{tr}\mathbf{A}_1\mathbf{A}_2 &= 0, & \text{tr}\mathbf{A}_1^2\mathbf{A}_2 &= 2k^4, & \text{tr}\mathbf{A}_2^2\mathbf{A}_1 &= 0, & \text{tr}\mathbf{A}_1^2\mathbf{A}_2^2 &= 4k^6. \end{aligned}$$

Thus, from Eq. (8.18.4), we have

$$\begin{aligned} [\mathbf{T}] &= -\rho[\mathbf{I}] + \mu_1 \begin{bmatrix} 0 & k & 0 \\ k & 0 & 0 \\ 0 & 0 & 0 \end{bmatrix} + \mu_2 \begin{bmatrix} k^2 & 0 & 0 \\ 0 & k^2 & 0 \\ 0 & 0 & 0 \end{bmatrix} + \mu_3 \begin{bmatrix} 0 & 0 & 0 \\ 0 & 2k^2 & 0 \\ 0 & 0 & 0 \end{bmatrix} + \mu_4 \begin{bmatrix} 0 & 0 & 0 \\ 0 & 4k^4 & 0 \\ 0 & 0 & 0 \end{bmatrix} + \\ &\mu_5 \begin{bmatrix} 0 & 2k^3 & 0 \\ 2k^3 & 0 & 0 \\ 0 & 0 & 0 \end{bmatrix} + \mu_6 \begin{bmatrix} 0 & 4k^5 & 0 \\ 4k^5 & 0 & 0 \\ 0 & 0 & 0 \end{bmatrix} + \mu_7 \begin{bmatrix} 0 & 0 & 0 \\ 0 & 4k^4 & 0 \\ 0 & 0 & 0 \end{bmatrix} + \mu_8 \begin{bmatrix} 0 & 0 & 0 \\ 0 & 8k^6 & 0 \\ 0 & 0 & 0 \end{bmatrix}. \end{aligned}$$

where μ_i 's are functions of k^2 . We note that the shear stress function $[\tau(k) \equiv T_{12}]$ is an odd function of the rate of shear k , whereas the normal stress functions $[\sigma_1 = T_{11} - T_{22}$ and $\sigma_2 = T_{22} - T_{33}]$ are even functions of k .

8.19 OBJECTIVE RATE OF STRESS

The stress tensor is objective [see Chapter 5C, Eq. (5.57.1)]; that is, in a change of frame,

$$\mathbf{T}^* = \mathbf{Q}(t)\mathbf{T}\mathbf{Q}^T(t). \quad (8.19.1)$$

Taking material derivative of the preceding equation, we obtain (*note: $D/Dt^* = D/Dt$*)

$$\frac{D\mathbf{T}^*}{Dt} = \frac{D\mathbf{Q}}{Dt}\mathbf{T}\mathbf{Q}^T + \mathbf{Q}\frac{D\mathbf{T}}{Dt}\mathbf{Q}^T + \mathbf{Q}\mathbf{T}\left(\frac{D\mathbf{Q}}{Dt}\right)^T. \quad (8.19.2)$$

The preceding equation shows that the material derivative of stress tensor \mathbf{T} is not objective.

That the stress rate $D\mathbf{T}/Dt$ is not objective is physically quite clear. Consider the case of a time-independent uniaxial state of stress with respect to the first observer. With respect to this observer, the stress rate $D\mathbf{T}/Dt$ is identically zero. Consider the second observer who rotates with respect to the first observer. To the second observer, the given stress state is rotating with respect to him and therefore, to him, the stress rate $D\mathbf{T}^*/Dt^*$ is not zero.

In the following, we present several stress rates at time t that are objective.

A. Corotational Derivative, Also Known as the Jaumann Derivative

Let us consider the tensor

$$\mathbf{J}(\tau) = \mathbf{R}_t^T(\tau)\mathbf{T}(\tau)\mathbf{R}_t(\tau). \quad (8.19.3)$$

We note that since $\mathbf{R}_t(t) = \mathbf{R}_t^T(t) = \mathbf{I}$, the tensor \mathbf{J} and the tensor \mathbf{T} are the same at time t . That is,

$$\mathbf{J}(t) = \mathbf{T}(t). \quad (8.19.4)$$

However, while $D\mathbf{T}/Dt$ is not an objective tensor, we will show that $[D\mathbf{J}(\tau)/D\tau]_{\tau=t}$ is an objective tensor. To show this, we note that in Section 8.13, we obtain, in a change of frame,

$$\mathbf{R}_t^* = \mathbf{Q}(\tau)\mathbf{R}_t(\tau)\mathbf{Q}^T(t). \quad (8.19.5)$$

Thus,

$$\mathbf{J}^*(\tau) = \mathbf{R}_t^{*\text{T}}(\tau) \mathbf{T}^*(\tau) \mathbf{R}_t^*(\tau) = [\mathbf{Q}(\tau) \mathbf{R}_t(\tau) \mathbf{Q}^{\text{T}}(t)]^{\text{T}} [\mathbf{Q}(\tau) \mathbf{T}(\tau) \mathbf{Q}^{\text{T}}(\tau)] [\mathbf{Q}(\tau) \mathbf{R}_t(\tau) \mathbf{Q}^{\text{T}}(t)] = \mathbf{Q}(t) \mathbf{R}_t^{\text{T}}(\tau) \mathbf{T}(\tau) \mathbf{R}_t(\tau) \mathbf{Q}^{\text{T}}(t).$$

That is,

$$\mathbf{J}^*(\tau) = \mathbf{Q}(t) \mathbf{J}(\tau) \mathbf{Q}^{\text{T}}(t), \quad (8.19.6)$$

and

$$\left[\frac{D^N \mathbf{J}^*(\tau)}{D\tau^N} \right]_{\tau=t} = \mathbf{Q}(t) \left[\frac{D^N \mathbf{J}(\tau)}{D\tau^N} \right]_{\tau=t} \mathbf{Q}^{\text{T}}(t), \quad N = 1, 2, 3, \dots \quad (8.19.7)$$

That is, the tensor $\mathbf{J}(\tau)$, as well as its material derivatives evaluated at time t , is objective. The derivative $[D\mathbf{J}(\tau)/D\tau]_{\tau=t}$ is known as the *corotational derivative* and will be denoted by $\overset{\circ}{\mathbf{T}}$. That is,

$$\overset{\circ}{\mathbf{T}} \equiv \left[\frac{D\mathbf{J}(\tau)}{D\tau} \right]_{\tau=t}. \quad (8.19.8)$$

It is called the *corotational derivative* because it is the derivative of \mathbf{T} at time t as seen by an observer who rotates with the material element (whose rotation tensor is \mathbf{R}). The higher derivatives will be denoted by

$$\overset{\circ}{\mathbf{T}}_N = [D^N \mathbf{J}(\tau)/D\tau^N]_{\tau=t}, \quad (8.19.9)$$

where $\overset{\circ}{\mathbf{T}}_1 = \overset{\circ}{\mathbf{T}}$. These corotational derivatives are also known as the *Jaumann derivatives*.

We now show

$$\overset{\circ}{\mathbf{T}} = \frac{D\mathbf{T}}{Dt} + \mathbf{T}(t)\mathbf{W}(t) - \mathbf{W}(t)\mathbf{T}(t), \quad (8.19.10)$$

where $\mathbf{W}(t)$ is the spin tensor of the element.

From Eq. (8.19.3), i.e., $\mathbf{J}(\tau) = \mathbf{R}_t^{\text{T}}(\tau) \mathbf{T}(\tau) \mathbf{R}_t(\tau)$, we have

$$\frac{D\mathbf{J}(\tau)}{D\tau} = \frac{D\mathbf{R}_t^{\text{T}}(\tau)}{D\tau} \mathbf{T}(\tau) \mathbf{R}_t(\tau) + \mathbf{R}_t^{\text{T}}(\tau) \frac{D\mathbf{T}(\tau)}{D\tau} \mathbf{R}_t(\tau) + \mathbf{R}_t^{\text{T}}(\tau) \mathbf{T}(\tau) \frac{D\mathbf{R}_t(\tau)}{D\tau}. \quad (8.19.11)$$

Evaluating the preceding equation at $\tau = t$ and noting that [see Eq. (8.12.7)]

$$\left[\frac{D\mathbf{R}_t(\tau)}{D\tau} \right]_{\tau=t} = \mathbf{W}(t), \quad \left[\frac{D\mathbf{R}_t^{\text{T}}(\tau)}{D\tau} \right]_{\tau=t} = \mathbf{W}^{\text{T}}(t) = -\mathbf{W}(t), \quad \text{and} \quad \mathbf{R}_t^{\text{T}}(t) = \mathbf{R}_t(t) = \mathbf{I},$$

Eq. (8.19.11) becomes Eq. (8.19.10).

B. Oldroyd Lower Convected Derivative

Let us consider the tensor

$$\mathbf{J}_L(\tau) = \mathbf{F}_t^{\text{T}}(\tau) \mathbf{T}(\tau) \mathbf{F}_t(\tau). \quad (8.19.12)$$

Again, since $\mathbf{F}_t(t) = \mathbf{F}_t^{\text{T}}(t) = \mathbf{I}$, the tensor \mathbf{J}_L and the tensor \mathbf{T} are the same at time t . That is,

$$\mathbf{J}_L(t) = \mathbf{T}(t). \quad (8.19.13)$$

We now show that $[D\mathbf{J}_L(\tau)/D\tau]_{\tau=t}$ is an objective tensor. To do so, we note that in Section 8.13, we obtained, in a change of frame,

$$\mathbf{F}_t^*(\tau) = \mathbf{Q}(\tau)\mathbf{F}_t(\tau)\mathbf{Q}^T(t). \quad (8.19.14)$$

Thus,

$$\begin{aligned} \mathbf{J}_L^*(\tau) &= [\mathbf{Q}(\tau)\mathbf{F}_t(\tau)\mathbf{Q}^T(t)]^T [\mathbf{Q}(\tau)\mathbf{T}(\tau)\mathbf{Q}^T(\tau)] [\mathbf{Q}(\tau)\mathbf{F}_t(\tau)\mathbf{Q}^T(t)] \\ &= \mathbf{Q}(t)\mathbf{F}_t^T(\tau)\mathbf{T}(\tau)\mathbf{F}_t(\tau)\mathbf{Q}^T(t). \end{aligned} \quad (8.19.15)$$

Thus,

$$\mathbf{J}_L^*(\tau) = \mathbf{Q}(t)\mathbf{J}_L(\tau)\mathbf{Q}^T(t), \quad (8.19.16)$$

and

$$\left[\frac{D^N \mathbf{J}_L^*(\tau)}{D\tau^N} \right]_{\tau=t} = \mathbf{Q}(t) \left[\frac{D^N \mathbf{J}_L(\tau)}{D\tau^N} \right]_{\tau=t} \mathbf{Q}^T(t), \quad N = 1, 2, 3, \dots \quad (8.19.17)$$

That is, the tensor $\mathbf{J}_L(\tau)$, as well as its material derivatives evaluated at time t , is objective. The derivative $[D\mathbf{J}_L(\tau)/D\tau]_{\tau=t}$ is known as the *Oldroyd lower convected derivative* and will be denoted by $\check{\mathbf{T}}$. That is,

$$\check{\mathbf{T}} \equiv \left[\frac{D\mathbf{J}_L(\tau)}{D\tau} \right]_{\tau=t}. \quad (8.19.18)$$

It is called a *convected* derivative because Oldroyd obtained the derivative by using “convected coordinates,” that is, coordinates that are embedded in the continuum and thereby deforming and rotating with the continuum.** The higher derivatives will be denoted by

$$\check{\mathbf{T}}_N \equiv \left[\frac{D^N \mathbf{J}_L(\tau)}{D\tau^N} \right]_{\tau=t}. \quad (8.19.19)$$

In Section 8.12, we derived that [see Eq. (8.12.3)]

$$\left[\frac{D\mathbf{F}_t(\tau)}{D\tau} \right]_{\tau=t} = \nabla \mathbf{v}. \quad (8.19.20)$$

Using this, one can show that (see Prob. 8.25)

$$\check{\mathbf{T}} = \frac{D\mathbf{T}}{Dt} + \mathbf{T}\nabla \mathbf{v} + (\nabla \mathbf{v})^T \mathbf{T}. \quad (8.19.21)$$

Further, since $\nabla \mathbf{v} = \mathbf{D} + \mathbf{W}$, Eq. (8.19.21) can also be written as

$$\check{\mathbf{T}} = \overset{\circ}{\mathbf{T}} + \mathbf{T}\mathbf{D} + \mathbf{D}\mathbf{T}. \quad (8.19.22)$$

It can be easily shown (see Prob. 8.29) that the lower convected derivative of the first Rivlin-Ericksen tensor \mathbf{A}_1 is the second Rivlin-Ericksen tensor \mathbf{A}_2 .

**The “lower convected derivatives” and the “upper convected derivatives” correspond to the derivatives of the covariant components and the contravariant components of the tensor, respectively, in a convected coordinate system that is embedded in the continuum and thereby moves and deforms with the continuum. This is the method used by Oldroyd to obtain objective derivatives.

C. Oldroyd Upper Convected Derivative

Let us consider the tensor

$$\mathbf{J}_U(\tau) = \mathbf{F}_t^{-1}(\tau)\mathbf{T}(\tau)\mathbf{F}_t^{-1T}(\tau). \quad (8.19.23)$$

Again, as in (A) and (B),

$$\mathbf{J}_U(t) = \mathbf{T}(t), \quad (8.19.24)$$

and the derivatives

$$\left[\frac{D^N \mathbf{J}_U(\tau)}{D\tau^N} \right]_{\tau=t}, \quad N = 1, 2, 3, \dots \quad (8.19.25)$$

can be shown to be objective tensors. These are known as the *Oldroyd upper convected derivatives* of \mathbf{T} , which will be denoted by $\hat{\mathbf{T}}$. It can also be derived (see Prob. 8.26) that

$$\hat{\mathbf{T}} \equiv \left[\frac{D\mathbf{J}_U(\tau)}{D\tau} \right]_{\tau=t} = \frac{D\mathbf{T}}{Dt} - \mathbf{T}(\nabla\mathbf{v})^T - (\nabla\mathbf{v})\mathbf{T} = \overset{\circ}{\mathbf{T}} - (\mathbf{T}\mathbf{D} + \mathbf{D}\mathbf{T}). \quad (8.19.26)$$

The preceding three objective time derivatives are perhaps the most well-known objective derivatives of objective tensors. There are many others. For example, $\overset{\circ}{\mathbf{T}} + \alpha(\mathbf{T}\mathbf{D} + \mathbf{D}\mathbf{T})$ are objective rates for the tensor \mathbf{T} for any scalar α , including the corotational rate ($\alpha = 0$), the Oldroyd lower convected rate ($\alpha = 1$), and the Oldroyd upper convected rate ($\alpha = -1$). When applied to stress tensors, they are known as *objective stress rates*.

Example 8.19.1

Given that the state of stress in a body is that of a uniaxial state of stress with

$$T_{11} = \sigma, \quad \text{all other } T_{ij} = 0$$

where σ is a constant. Clearly, the stress rate is zero at all places and at all times. Consider a second observer, represented by the starred frame, which rotates with an angular velocity ω relative the unstarred frame. That is,

$$\begin{bmatrix} x_1^* \\ x_2^* \\ x_3^* \end{bmatrix} = \begin{bmatrix} \cos \omega t & -\sin \omega t & 0 \\ \sin \omega t & \cos \omega t & 0 \\ 0 & 0 & 1 \end{bmatrix} \begin{bmatrix} x_1 \\ x_2 \\ x_3 \end{bmatrix}, \quad [\mathbf{Q}] = \begin{bmatrix} \cos \omega t & -\sin \omega t & 0 \\ \sin \omega t & \cos \omega t & 0 \\ 0 & 0 & 1 \end{bmatrix}. \quad (i)$$

For the starred frame, find (a) the time-dependent state of stress, (b) the stress rate, and (c) the corotational stress rate.

Solution

(a) The time-dependent $[\mathbf{T}^*]$ is

$$[\mathbf{T}^*] = [\mathbf{Q}][\mathbf{T}][\mathbf{Q}]^T = \sigma \begin{bmatrix} \cos^2 \omega t & \sin^2 \omega t / 2 & 0 \\ \sin^2 \omega t / 2 & \sin^2 \omega t & 0 \\ 0 & 0 & 0 \end{bmatrix}. \quad (ii)$$

(b)

$$\left[\frac{D\mathbf{T}^*}{Dt} \right] = \sigma \omega \begin{bmatrix} -2 \sin \omega t \cos \omega t & \cos^2 \omega t & 0 \\ \cos^2 \omega t & 2 \sin \omega t \cos \omega t & 0 \\ 0 & 0 & 0 \end{bmatrix}. \quad (iii)$$

That is, for the $*$ frame, the stress rate is not zero due to its own rotation relative to the unstarred frame. To obtain a stress rate that is not dependent on the observer's own rotation, we calculate the corotational stress rate in (c).

(c) From Eq. (5.56.20), i.e., $\nabla^* \mathbf{v}^* = \mathbf{Q}(\nabla \mathbf{v})\mathbf{Q}^T + \dot{\mathbf{Q}}\mathbf{Q}^T$, we have, with $\nabla \mathbf{v} = 0$,

$$\begin{aligned} [\nabla^* \mathbf{v}^*] &= [d\mathbf{Q}/dt][\mathbf{Q}]^T = \omega \begin{bmatrix} -\sin \omega t & -\cos \omega t & 0 \\ \cos \omega t & -\sin \omega t & 0 \\ 0 & 0 & 1 \end{bmatrix} \begin{bmatrix} \cos \omega t & \sin \omega t & 0 \\ -\sin \omega t & \cos \omega t & 0 \\ 0 & 0 & 1 \end{bmatrix} \\ &= \omega \begin{bmatrix} 0 & -1 & 0 \\ 1 & 0 & 0 \\ 0 & 0 & 1 \end{bmatrix}. \end{aligned} \quad (\text{iv})$$

Thus,

$$[\mathbf{W}^*] = [\nabla^* \mathbf{v}^*]_{\text{Antisym}} = \omega \begin{bmatrix} 0 & -1 & 0 \\ 1 & 0 & 0 \\ 0 & 0 & 0 \end{bmatrix}, \quad (\text{v})$$

so that

$$[\mathbf{T}^* \mathbf{W}^*] - [\mathbf{W}^* \mathbf{T}^*] = \sigma \omega \begin{bmatrix} 2 \cos \omega t \sin \omega t & -\cos 2\omega t & 0 \\ -\cos 2\omega t & -2 \cos \omega t \sin \omega t & 0 \\ 0 & 0 & 0 \end{bmatrix}. \quad (\text{vi})$$

Thus, the corotational stress rate is

$$[\overset{\circ}{\mathbf{T}}^*] = [D\mathbf{T}^*/Dt] + [\mathbf{T}^* \mathbf{W}^*] - [\mathbf{W}^* \mathbf{T}^*] = [\mathbf{0}]. \quad (\text{vii})$$

This is the same stress rate as the first observer.

8.20 RATE-TYPE CONSTITUTIVE EQUATIONS

Constitutive equations of the following form are known as *rate-type nonlinear constitutive equations*:

$$\mathbf{T} = -p\mathbf{I} + \mathbf{S}, \quad (8.20.1)$$

and

$$\mathbf{S} + \lambda_1 \overset{*}{\mathbf{S}} + \lambda_2 \overset{**}{\mathbf{S}} + \dots = 2\mu_1 \mathbf{D} + \mu_2 \overset{*}{\mathbf{D}} + \dots \quad (8.20.2)$$

where \mathbf{S} is extra stress and \mathbf{D} is the rate of deformation. The super star or stars in \mathbf{S} and \mathbf{D} denote some chosen objective time derivatives or higher derivatives. For example, if the corotational derivative is chosen, then

$$\overset{*}{\mathbf{S}} \equiv \overset{\circ}{\mathbf{S}} = \frac{D\mathbf{S}}{Dt} + \mathbf{S}\mathbf{W} - \mathbf{W}\mathbf{S} \quad \text{and} \quad \overset{*}{\mathbf{D}} = \overset{\circ}{\mathbf{D}} = \frac{D\mathbf{D}}{Dt} + \mathbf{D}\mathbf{W} - \mathbf{W}\mathbf{D}, \quad \text{etc.} \quad (8.20.3)$$

Equation (8.20.1), together with Eq. (8.20.2), may be regarded as a generalization of the generalized linear Maxwell fluid defined in Section 8.2. The following are some examples.

A. The Convected Maxwell Fluid

The convected Maxwell fluid is defined by the constitutive equation

$$\mathbf{T} = -p\mathbf{I} + \mathbf{S}, \quad \mathbf{S} + \lambda \overset{\circ}{\mathbf{S}} = 2\mu\mathbf{D}, \quad \overset{\circ}{\mathbf{S}} = \frac{D\mathbf{S}}{Dt} + \mathbf{S}\mathbf{W} - \mathbf{W}\mathbf{S}. \quad (8.20.4)$$

Example 8.20.1

Obtain the stress components for the convected Maxwell fluid in a simple shearing flow.

Solution

The velocity field for the simple shearing flow is

$$v_1 = kx_2, \quad v_2 = v_3 = 0. \quad (8.20.5)$$

For this flow, the rate of deformation and the spin tensors are

$$[\mathbf{D}] = \begin{bmatrix} 0 & k/2 & 0 \\ k/2 & 0 & 0 \\ 0 & 0 & 0 \end{bmatrix}, \quad [\mathbf{W}] = \begin{bmatrix} 0 & k/2 & 0 \\ -k/2 & 0 & 0 \\ 0 & 0 & 0 \end{bmatrix}. \quad (8.20.6)$$

Thus,

$$[\mathbf{S}\mathbf{W}] = (k/2) \begin{bmatrix} -S_{12} & S_{11} & 0 \\ -S_{22} & S_{21} & 0 \\ -S_{32} & S_{31} & 0 \end{bmatrix}, \quad [\mathbf{W}\mathbf{S}] = (k/2) \begin{bmatrix} S_{21} & S_{22} & S_{23} \\ -S_{11} & -S_{12} & -S_{13} \\ 0 & 0 & 0 \end{bmatrix},$$

$$[\mathbf{S}\mathbf{W}] - [\mathbf{W}\mathbf{S}] = (k/2) \begin{bmatrix} -2S_{12} & S_{11} - S_{22} & -S_{23} \\ S_{11} - S_{22} & 2S_{12} & S_{13} \\ -S_{32} & S_{31} & 0 \end{bmatrix}.$$

Since the flow is steady and the rate of deformation is a constant, independent of position, the stress field is also independent of time and position. Thus, $D\mathbf{S}/Dt = 0$ so that

$$\overset{\circ}{\mathbf{S}} = [\mathbf{S}\mathbf{W}] - [\mathbf{W}\mathbf{S}] = (k/2) \begin{bmatrix} -2S_{12} & S_{11} - S_{22} & -S_{23} \\ S_{11} - S_{22} & 2S_{12} & S_{13} \\ -S_{32} & S_{31} & 0 \end{bmatrix}. \quad (8.20.7)$$

Thus, Eq. (8.20.4) gives the following six equations:

$$S_{11} - k\lambda S_{12} = 0, \quad S_{12} + (k\lambda/2)(S_{11} - S_{22}) = \mu k, \quad S_{13} - (k\lambda/2)S_{23} = 0,$$

$$S_{22} + k\lambda S_{12} = 0, \quad S_{23} + (k\lambda/2)S_{13} = 0, \quad S_{33} = 0.$$

Thus,

$$S_{11} = \frac{\lambda\mu k^2}{1 + (k\lambda)^2}, \quad S_{12} = \frac{\mu k}{1 + (k\lambda)^2}, \quad S_{22} = -\frac{\lambda\mu k^2}{1 + (k\lambda)^2}, \quad S_{13} = S_{23} = S_{33} = 0. \quad (8.20.8)$$

The shear stress function is

$$\tau(k) = S_{12} = \frac{\mu k}{1 + (k\lambda)^2}. \quad (8.20.9)$$

The apparent viscosity is

$$\eta(k) = \frac{\mu(k)}{k} = \frac{\mu}{1 + (k\lambda)^2}. \quad (8.20.10)$$

The normal stress functions are

$$\sigma_1(k) \equiv T_{11} - T_{22} = \frac{2\mu k^2 \lambda}{1 + (k\lambda)^2}, \quad \sigma_2(k) \equiv T_{22} - T_{33} = -\frac{\mu k^2 \lambda}{1 + (k\lambda)^2}. \quad (8.20.11)$$

B. The Corotational Jeffrey Fluid

The corotational Jeffrey fluid is defined by the constitutive equation

$$\mathbf{T} = -p\mathbf{I} + \mathbf{S}, \quad \mathbf{S} + \lambda_1 \dot{\mathbf{S}} = 2\mu(\mathbf{D} + \lambda_2 \dot{\mathbf{D}}), \quad (8.20.12)$$

where

$$\dot{\mathbf{S}} = \frac{D\mathbf{S}}{Dt} + \mathbf{S}\mathbf{W} - \mathbf{W}\mathbf{S}, \quad \dot{\mathbf{D}} = \frac{D\mathbf{D}}{Dt} + \mathbf{D}\mathbf{W} - \mathbf{W}\mathbf{D}. \quad (8.20.13)$$

Example 8.20.2

Obtain the stress components for the corotational Jeffrey fluid in a simple shearing flow.

Solution

From the previous example, we have

$$\dot{\mathbf{S}} = [\mathbf{0}] + [\mathbf{S}\mathbf{W}] - [\mathbf{W}\mathbf{S}] = (k/2) \begin{bmatrix} -2S_{12} & S_{11} - S_{22} & -S_{23} \\ S_{11} - S_{22} & 2S_{12} & S_{13} \\ -S_{32} & S_{31} & 0 \end{bmatrix}. \quad (8.20.14)$$

Now

$$\dot{\mathbf{D}} = [\mathbf{0}] + [\mathbf{D}\mathbf{W}] - [\mathbf{W}\mathbf{D}] = \begin{bmatrix} -k^2/2 & 0 & 0 \\ 0 & k^2/2 & 0 \\ 0 & 0 & 0 \end{bmatrix}. \quad (8.20.15)$$

Thus, Eq. (8.20.12) gives

$$S_{11} - k\lambda_1 S_{12} = -\mu\lambda_2 k^2, \quad S_{12} + (k\lambda_1/2)(S_{11} - S_{22}) = \mu k, \quad S_{13} - (k\lambda_1/2)S_{23} = 0, \\ S_{22} + k\lambda_1 S_{12} = \mu\lambda_2 k^2, \quad S_{23} + (k\lambda_1/2)S_{13} = 0, \quad S_{33} = 0.$$

These equations give

$$S_{12} = \frac{\mu k(1 + \lambda_1 \lambda_2 k^2)}{1 + \lambda_1^2 k^2}, \quad S_{11} = \frac{\mu k^2(\lambda_1 - \lambda_2)}{1 + \lambda_1^2 k^2}, \quad S_{22} = \frac{\mu k^2(\lambda_2 - \lambda_1)}{1 + \lambda_1^2 k^2} \\ S_{13} = S_{23} = S_{33} = 0. \quad (8.20.16)$$

Thus, the apparent viscosity is

$$\eta(k) = \frac{S_{12}}{k} = \frac{\mu(1 + \lambda_1\lambda_2k^2)}{1 + \lambda_1^2k^2}, \quad (8.20.17)$$

and the normal stress functions are

$$\sigma_1 \equiv T_{11} - T_{22} = \frac{2\mu k^2(\lambda_1 - \lambda_2)}{1 + \lambda_1^2k^2}, \quad \sigma_2 \equiv T_{22} - T_{33} = \frac{\mu k^2(\lambda_2 - \lambda_1)}{1 + \lambda_1^2k^2}. \quad (8.20.18)$$

C. The Oldroyd 3-Constant Fluid

The *Oldroyd 3-constant model* (also known as the *Oldroyd fluid A*) is defined by the following constitutive equations:

$$\mathbf{T} = -p\mathbf{I} + \mathbf{S}, \quad \mathbf{S} + \lambda_1\hat{\mathbf{S}} = 2\mu(\mathbf{D} + \lambda_2\hat{\mathbf{D}}), \quad (8.20.19)$$

where

$$\hat{\mathbf{S}} = \overset{\circ}{\mathbf{S}} - (\mathbf{S}\mathbf{D} + \mathbf{D}\mathbf{S}) \quad \text{and} \quad \hat{\mathbf{D}} = \overset{\circ}{\mathbf{D}} - (\mathbf{D}\mathbf{D} + \mathbf{D}\mathbf{D}) = \overset{\circ}{\mathbf{D}} - 2\mathbf{D}^2 \quad (8.20.20)$$

are the Oldroyd upper convected derivative of \mathbf{S} and \mathbf{D} . By considering the simple shearing flow as was done in the previous two examples, we can obtain the apparent viscosity as

$$\eta(k) = \frac{S_{12}}{k} = \mu = \text{a constant} \quad (8.20.21)$$

and the normal stress functions as

$$\sigma_1 \equiv T_{11} - T_{22} = 2\mu(\lambda_1 - \lambda_2)k^2, \quad \sigma_2 \equiv T_{22} - T_{33} = 0. \quad (8.20.22)$$

D. The Oldroyd 4-Constant Fluid

The Oldroyd 4-constant fluid is defined by the following constitutive equations:

$$\mathbf{T} = -p\mathbf{I} + \mathbf{S}, \quad \mathbf{S} + \lambda_1\hat{\mathbf{S}} + \mu_o(\text{tr } \mathbf{S})\mathbf{D} = 2\mu(\mathbf{D} + \lambda_2\hat{\mathbf{D}}), \quad (8.20.23)$$

where

$$\hat{\mathbf{S}} = \overset{\circ}{\mathbf{S}} - (\mathbf{S}\mathbf{D} + \mathbf{D}\mathbf{S}) \quad \text{and} \quad \hat{\mathbf{D}} = \overset{\circ}{\mathbf{D}} - (\mathbf{D}\mathbf{D} + \mathbf{D}\mathbf{D}) = \overset{\circ}{\mathbf{D}} - 2\mathbf{D}^2 \quad (8.20.24)$$

are the Oldroyd upper convected derivative of \mathbf{S} and \mathbf{D} . We note that in this model, an additional term $\mu_o(\text{tr } \mathbf{S})\mathbf{D}$ is added to the left-hand side. This term is obviously an objective term since both \mathbf{S} and \mathbf{D} are objective. The inclusion of this term will make the viscosity of the fluid dependent on the rate of deformation.

By considering the simple shearing flow as was done in the previous models, we can obtain the following results (see Prob. 8.38):

$$S_{11} = \frac{2\mu k^2(\lambda_1 - \lambda_2)}{(1 + \lambda_1\mu_o k^2)}, \quad S_{12} = \frac{\mu k(1 + \lambda_2\mu_o k^2)}{(1 + \lambda_1\mu_o k^2)}, \quad \text{all other } S_{ij} = 0. \quad (8.20.25)$$

Thus, the apparent viscosity is

$$\eta(k) \equiv \frac{S_{12}}{k} = \frac{\mu(1 + \lambda_2\mu_0k^2)}{(1 + \lambda_1\mu_0k^2)}, \quad (8.20.26)$$

and the normal stress functions are

$$\sigma_1 = T_{11} - T_{22} = \frac{2\mu k^2(\lambda_1 - \lambda_2)}{(1 + \lambda_1\mu_0k^2)}, \quad \sigma_2 = T_{22} - T_{33} = 0. \quad (8.20.27)$$

PART C: VISCOMETRIC FLOW OF AN INCOMPRESSIBLE SIMPLE FLUID

8.21 VISCOMETRIC FLOW

Viscometric flows may be defined as the class of flows that satisfies the following conditions:

1. At all times and at every material point, the history of the relative right Cauchy-Green deformation tensor can be expressed as

$$\mathbf{C}_t(\tau) = \mathbf{I} + (\tau - t)\mathbf{A}_1 + \frac{(\tau - t)^2}{2}\mathbf{A}_2. \quad (8.21.1)$$

2. There exists an orthonormal basis (\mathbf{n}_i) with respect to which the only nonzero Rivlin-Ericksen tensors are given by

$$[\mathbf{A}_1] = \begin{bmatrix} 0 & k & 0 \\ k & 0 & 0 \\ 0 & 0 & 0 \end{bmatrix}_{\{\mathbf{n}_i\}}, \quad [\mathbf{A}_2] = \begin{bmatrix} 0 & 0 & 0 \\ 0 & 2k^2 & 0 \\ 0 & 0 & 0 \end{bmatrix}_{\{\mathbf{n}_i\}}. \quad (8.21.2)$$

The orthonormal basis (\mathbf{n}_i) in general depends on the position of the material element.

The statement given in point 2 is equivalent to the following: There exists an orthonormal basis (\mathbf{n}_i) with respect to which

$$\mathbf{A}_1 = k(\mathbf{N} + \mathbf{N}^T), \quad \mathbf{A}_2 = 2k^2\mathbf{N}^T\mathbf{N}, \quad (8.21.3)$$

where the matrix of \mathbf{N} with respect to (\mathbf{n}_i) is given by

$$[\mathbf{N}] = \begin{bmatrix} 0 & 1 & 0 \\ 0 & 0 & 0 \\ 0 & 0 & 0 \end{bmatrix}_{\{\mathbf{n}_i\}}. \quad (8.21.4)$$

In the following examples, we demonstrate that simple shearing flow, plane Poiseuille flow, Poiseuille flow, and Couette flow are all viscometric flows.

Example 8.21.1

Consider the unidirectional flow with a velocity field given in Cartesian coordinates as

$$v_1 = v(x_2), \quad v_2 = v_3 = 0. \quad (8.21.5)$$

Show that it is a viscometric flow. We note that the unidirectional flow includes the simple shearing flow and the plane Poiseuille flow.

Solution

In Example 8.10.1, we obtained that for this flow, the history of $\mathbf{C}_t(\tau)$ is given by Eq. (8.21.1), and the matrix of the two nonzero Rivlin-Ericksen tensors \mathbf{A}_1 and \mathbf{A}_2 with respect to the rectangular Cartesian basis are given in Eq. (8.21.2), where $k = k(x_2)$. Thus, the given unidirectional flows are viscometric flows and the basis (\mathbf{n}_i) , with respect to which \mathbf{A}_1 and \mathbf{A}_2 have the forms given in Eq. (8.21.2), is clearly $\{\mathbf{e}_1, \mathbf{e}_2, \mathbf{e}_3\}$.

Example 8.21.2

Consider the axisymmetric flow with a velocity field given in cylindrical coordinates as

$$v_r = 0, \quad v_\theta = 0, \quad v_z = v(r). \quad (8.21.6)$$

Show that this is a viscometric flow. Find the basis (\mathbf{n}_i) with respect to which \mathbf{A}_1 and \mathbf{A}_2 have the forms given in Eq. (8.21.2).

Solution

In Example 8.10.2, we obtained that for this flow, the history of $\mathbf{C}_t(\tau)$ is given by Eq. (8.21.1), i.e.,

$$\mathbf{C}_t(\tau) = \mathbf{I} + (\tau - t)\mathbf{A}_1 + \frac{(\tau - t)^2}{2}\mathbf{A}_2,$$

and the matrix of the two nonzero Rivlin-Ericksen tensors \mathbf{A}_1 and \mathbf{A}_2 are given by

$$[\mathbf{A}_1]_{\{\mathbf{e}_r, \mathbf{e}_\theta, \mathbf{e}_z\}} = \begin{bmatrix} 0 & 0 & k(r) \\ 0 & 0 & 0 \\ k(r) & 0 & 0 \end{bmatrix}_{\{\mathbf{e}_r, \mathbf{e}_\theta, \mathbf{e}_z\}}, \quad [\mathbf{A}_2]_{\{\mathbf{e}_r, \mathbf{e}_\theta, \mathbf{e}_z\}} = \begin{bmatrix} 2k^2(r) & 0 & 0 \\ 0 & 0 & 0 \\ 0 & 0 & 0 \end{bmatrix}_{\{\mathbf{e}_r, \mathbf{e}_\theta, \mathbf{e}_z\}}. \quad (8.21.7)$$

Let

$$\mathbf{n}_1 = \mathbf{e}_z, \quad \mathbf{n}_2 = \mathbf{e}_r, \quad \mathbf{n}_3 = \mathbf{e}_\theta, \quad (8.21.8)$$

so that $(\mathbf{A}_1)_{11} = (\mathbf{A}_1)_{zz}$, $(\mathbf{A}_1)_{12} = (\mathbf{A}_1)_{zr}$, $(\mathbf{A}_1)_{13} = (\mathbf{A}_1)_{z\theta}$, etc., that is,

$$[\mathbf{A}_1]_{\{\mathbf{n}_1, \mathbf{n}_2, \mathbf{n}_3\}} = \begin{bmatrix} 0 & k(r) & 0 \\ k(r) & 0 & 0 \\ 0 & 0 & 0 \end{bmatrix}_{\{\mathbf{n}_i\}}, \quad [\mathbf{A}_2]_{\{\mathbf{n}_1, \mathbf{n}_2, \mathbf{n}_3\}} = \begin{bmatrix} 0 & 0 & 0 \\ 0 & 2k^2(r) & 0 \\ 0 & 0 & 0 \end{bmatrix}_{\{\mathbf{n}_i\}}. \quad (8.21.9)$$

Thus, this is viscometric flow for which the basis (\mathbf{n}_i) is related to the cylindrical basis $\{\mathbf{e}_r, \mathbf{e}_\theta, \mathbf{e}_z\}$ by Eq. (8.21.8) (see Figure 8.21-1).

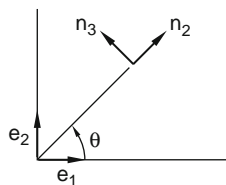
FIGURE 8.21-1

Example 8.21.3

Consider the Couette flow with a velocity field given in cylindrical coordinates as

$$v_r = 0, \quad v_\theta = v(r) = r\omega(r), \quad v_z = 0.$$

Show that this is a viscometric flow and find the basis $\{\mathbf{n}_i\}$ with respect to which \mathbf{A}_1 and \mathbf{A}_2 have the form given in Eq. (8.21.2).

Solution

For the given velocity field, we obtained in Example 8.10.3

$$[\mathbf{C}_t(\tau)]_{\{\mathbf{e}_r, \mathbf{e}_\theta, \mathbf{e}_z\}} = [\mathbf{I}] + (\tau - t) \begin{bmatrix} 0 & k(r) & 0 \\ k(r) & 0 & 0 \\ 0 & 0 & 0 \end{bmatrix} + \frac{(\tau - t)^2}{2} \begin{bmatrix} 2k^2(r) & 0 & 0 \\ 0 & 0 & 0 \\ 0 & 0 & 0 \end{bmatrix}, \quad (8.21.10)$$

where

$$k(r) = \frac{dv}{dr} - \frac{v}{r} = \frac{rd\omega}{dr}. \quad (8.21.11)$$

The nonzero Rivlin-Ericksen tensors with respect to $\{\mathbf{e}_r, \mathbf{e}_\theta, \mathbf{e}_z\}$ are

$$[\mathbf{A}_1] = \begin{bmatrix} 0 & k(r) & 0 \\ k(r) & 0 & 0 \\ 0 & 0 & 0 \end{bmatrix}_{\{\mathbf{e}_r, \mathbf{e}_\theta, \mathbf{e}_z\}}, \quad [\mathbf{A}_2] = \begin{bmatrix} 2k^2(r) & 0 & 0 \\ 0 & 0 & 0 \\ 0 & 0 & 0 \end{bmatrix}_{\{\mathbf{e}_r, \mathbf{e}_\theta, \mathbf{e}_z\}}. \quad (8.21.12)$$

Let $\{\mathbf{n}_1, \mathbf{n}_2, \mathbf{n}_3\} \equiv \{\mathbf{e}_\theta, \mathbf{e}_r, \mathbf{e}_z\}$, then

$$[\mathbf{A}_1] = \begin{bmatrix} 0 & k(r) & 0 \\ k(r) & 0 & 0 \\ 0 & 0 & 0 \end{bmatrix}_{\{\mathbf{n}_1, \mathbf{n}_2, \mathbf{n}_3\}}, \quad [\mathbf{A}_2] = \begin{bmatrix} 0 & 0 & 0 \\ 0 & 2k^2(r) & 0 \\ 0 & 0 & 0 \end{bmatrix}_{\{\mathbf{n}_1, \mathbf{n}_2, \mathbf{n}_3\}}. \quad (8.21.13)$$

which have the form given in Eq. (8.21.2).

8.22 STRESSES IN VISCOMETRIC FLOW OF AN INCOMPRESSIBLE SIMPLE FLUID

When a simple fluid is in viscometric flow, its history of deformation $\mathbf{C}_t(\tau)$ is completely characterized by the two nonzero Rivlin-Ericksen tensors \mathbf{A}_1 and \mathbf{A}_2 . Thus, the functional in Eq. (8.15.2) becomes simply a function of \mathbf{A}_1 and \mathbf{A}_2 . That is,

$$\mathbf{T} = -p\mathbf{I} + \mathbf{f}(\mathbf{A}_1, \mathbf{A}_2), \quad (8.22.1)$$

where the Rivlin-Ericksen tensors \mathbf{A}_1 and \mathbf{A}_2 are expressible as

$$\mathbf{A}_1 = k(\mathbf{N} + \mathbf{N}^T), \quad \mathbf{A}_2 = 2k^2\mathbf{N}^T\mathbf{N}, \quad (8.22.2)$$

where the matrix of \mathbf{N} relative to some choice of basis $\{\mathbf{n}_i\}$ is

$$[\mathbf{N}] = \begin{bmatrix} 0 & 1 & 0 \\ 0 & 0 & 0 \\ 0 & 0 & 0 \end{bmatrix}_{\{\mathbf{n}_i\}}. \quad (8.22.3)$$

Furthermore, the objectivity condition, Eq. (8.15.5), is

$$\mathbf{f}(\mathbf{QA}_1\mathbf{Q}^T, \mathbf{QA}_2\mathbf{Q}^T) = \mathbf{Q}(t)\mathbf{f}(\mathbf{A}_1, \mathbf{A}_2)\mathbf{Q}^T(t). \quad (8.22.4)$$

In the following, we show that with respect to the basis $\{\mathbf{n}_i\}$, $T_{13} = T_{31} = T_{23} = T_{32} = 0$ and the normal stresses are all different from one another.

Let us choose an orthogonal tensor \mathbf{Q} such that

$$[\mathbf{Q}]_{\{\mathbf{n}_i\}} = \begin{bmatrix} 1 & 0 & 0 \\ 0 & 1 & 0 \\ 0 & 0 & -1 \end{bmatrix}_{\{\mathbf{n}_i\}}, \quad (8.22.5)$$

then,

$$[\mathbf{Q}][\mathbf{N}][\mathbf{Q}^T] = \begin{bmatrix} 1 & 0 & 0 \\ 0 & 1 & 0 \\ 0 & 0 & -1 \end{bmatrix} \begin{bmatrix} 0 & 1 & 0 \\ 0 & 0 & 0 \\ 0 & 0 & 0 \end{bmatrix} \begin{bmatrix} 1 & 0 & 0 \\ 0 & 1 & 0 \\ 0 & 0 & -1 \end{bmatrix} = \begin{bmatrix} 0 & 1 & 0 \\ 0 & 0 & 0 \\ 0 & 0 & 0 \end{bmatrix} = [\mathbf{N}], \quad (8.22.6)$$

and

$$[\mathbf{Q}][\mathbf{N}^T\mathbf{N}][\mathbf{Q}^T] = \begin{bmatrix} 1 & 0 & 0 \\ 0 & 1 & 0 \\ 0 & 0 & -1 \end{bmatrix} \begin{bmatrix} 0 & 0 & 0 \\ 0 & 1 & 0 \\ 0 & 0 & 0 \end{bmatrix} \begin{bmatrix} 1 & 0 & 0 \\ 0 & 1 & 0 \\ 0 & 0 & -1 \end{bmatrix} = \begin{bmatrix} 0 & 0 & 0 \\ 0 & 1 & 0 \\ 0 & 0 & 0 \end{bmatrix} = [\mathbf{N}^T\mathbf{N}]. \quad (8.22.7)$$

That is, for this choice of \mathbf{Q} ,

$$\mathbf{Q}\mathbf{N}\mathbf{Q}^T = \mathbf{N} \quad \text{and} \quad \mathbf{Q}\mathbf{N}^T\mathbf{N}\mathbf{Q}^T = \mathbf{N}^T\mathbf{N}. \quad (8.22.8)$$

Thus, Eq. (8.22.2)

$$\mathbf{QA}_1\mathbf{Q}^T = k\mathbf{Q}(\mathbf{N} + \mathbf{N}^T)\mathbf{Q}^T = k(\mathbf{N} + \mathbf{N}^T) = \mathbf{A}_1, \quad (8.22.9)$$

and

$$\mathbf{QA}_2\mathbf{Q}^T = 2k^2\mathbf{Q}\mathbf{N}^T\mathbf{N}\mathbf{Q}^T = 2k^2\mathbf{N}^T\mathbf{N} = \mathbf{A}_2. \quad (8.22.10)$$

Now, from Eq. (8.22.1), Eq. (8.22.4), Eq. (8.22.9), and Eq. (8.22.10), for this particular choice of \mathbf{Q} ,

$$\mathbf{QTQ}^T = -p\mathbf{I} + \mathbf{Q}\mathbf{f}(\mathbf{A}_1, \mathbf{A}_2)\mathbf{Q}^T = -p\mathbf{I} + \mathbf{f}(\mathbf{QA}_1\mathbf{Q}^T, \mathbf{QA}_2\mathbf{Q}^T) = -p\mathbf{I} + \mathbf{f}(\mathbf{A}_1, \mathbf{A}_2) \quad (8.22.11)$$

i.e., for this \mathbf{Q} ,

$$\mathbf{QTQ}^T = \mathbf{T}. \quad (8.22.12)$$

Thus,

$$\begin{bmatrix} 1 & 0 & 0 \\ 0 & 1 & 0 \\ 0 & 0 & -1 \end{bmatrix} \begin{bmatrix} T_{11} & T_{12} & T_{13} \\ T_{21} & T_{22} & T_{23} \\ T_{31} & T_{32} & T_{33} \end{bmatrix} \begin{bmatrix} 1 & 0 & 0 \\ 0 & 1 & 0 \\ 0 & 0 & -1 \end{bmatrix} = \begin{bmatrix} T_{11} & T_{12} & T_{13} \\ T_{21} & T_{22} & T_{23} \\ T_{31} & T_{32} & T_{33} \end{bmatrix}.$$

Carrying out the matrix multiplication, one obtains

$$\begin{bmatrix} T_{11} & T_{12} & -T_{13} \\ T_{21} & T_{22} & -T_{23} \\ -T_{31} & -T_{32} & T_{33} \end{bmatrix} = \begin{bmatrix} T_{11} & T_{12} & T_{13} \\ T_{21} & T_{22} & T_{23} \\ T_{31} & T_{32} & T_{33} \end{bmatrix}.$$

The preceding equation leads to

$$T_{13} = T_{31} = T_{23} = T_{32} = 0. \quad (8.22.13)$$

Since \mathbf{A}_1 and \mathbf{A}_2 depend only on k , the nonzero stress components with respect to the basis $\{\mathbf{n}_i\}$ are

$$T_{12} = S_{12} \equiv \tau(k), \quad T_{11} = -p + S_{11}(k), \quad T_{22} = -p + S_{22}(k), \quad T_{33} = -p + S_{33}(k). \quad (8.22.14)$$

Defining the normal stress functions by the equations

$$\sigma_1 \equiv T_{11} - T_{22} \quad \text{and} \quad \sigma_2 \equiv T_{22} - T_{33}, \quad (8.22.15)$$

we can write the stress components of a simple fluid in viscometric flows as follows:

$$T_{12} = \tau(k), \quad T_{11} = T_{22} + \sigma_1(k), \quad T_{22} = T_{33} + \sigma_2(k), \quad T_{13} = T_{31} = T_{23} = T_{32} = 0. \quad (8.22.16)$$

As mentioned earlier in Part B, the function $\tau(k)$ is called the *shear stress function* and the functions $\sigma_1(k)$ and $\sigma_2(k)$ are called the *normal stress functions*. These three functions are known as the *viscometric functions*. These functions, when determined from the experiment on *one* viscometric flow of a simple fluid, determine completely the properties of the fluid in any other viscometric flow.

It can be shown that (see Prob. 8.39)

$$\tau(-k) = -\tau(k), \quad \sigma_1(-k) = \sigma_1(k), \quad \sigma_2(-k) = \sigma_2(k). \quad (8.22.17)$$

That is, $\tau(k)$ is an odd function of k , while $\sigma_1(k)$ and $\sigma_2(k)$ are even functions of k .

For a Newtonian fluid, such as water, in simple shearing flow, $\tau(k) = \mu k$, $\sigma_1 = 0$ and $\sigma_2 = 0$. For a non-Newtonian fluid, such as a polymeric solution, for small k , the viscometric functions can be approximated by a few terms of their Taylor series expansion. Noting that $\tau(k)$ is an odd function of k , we have

$$\tau(k) = \mu k + \mu_1 k^3 + \dots \quad (8.22.18)$$

and

$$\sigma_1(k) = s_1^{(1)} k^2 + s_2^{(1)} k^4 + \dots, \quad \sigma_2(k) = s_1^{(2)} k^2 + s_2^{(2)} k^4 + \dots \quad (8.22.19)$$

Since the deviation from Newtonian behavior is of the order of k^2 for σ_1 and σ_2 but of the order of k^3 for τ , it is expected that the deviation of the normal stresses will manifest themselves within the range of k in which the response of shear stress remains essentially the same as that of a Newtonian fluid.

8.23 CHANNEL FLOW

We now consider the steady unidirectional flow between two infinite parallel fixed plates. That is,

$$v_1 = v(x_2), \quad v_2 = v_3 = 0, \quad (8.23.1)$$

with

$$v(\pm h/2) = 0. \quad (8.23.2)$$

We saw in Example 8.21.1, that the basis $\{\mathbf{n}_i\}$ for which the stress components are given by Eq. (8.22.14) is the Cartesian basis $\{\mathbf{e}_i\}$. That is, with $k(x_2) \equiv dv/dx_2$,

$$T_{12} = S_{12} \equiv \tau(k), \quad T_{11} = -p + S_{11}(k), \quad T_{22} = -p + S_{22}(k), \quad T_{33} = -p + S_{33}(k). \quad (8.23.3)$$

Substituting the preceding equations in the equations of motion $\partial T_{ij}/\partial x_j = 0$ and noting that k depends only on x_2 , we get, in the absence of body forces,

$$-\frac{\partial p}{\partial x_1} + \frac{d\tau}{dx_2} = 0, \quad -\frac{\partial p}{\partial x_2} + \frac{dS_{22}}{dx_2} = 0, \quad -\frac{\partial p}{\partial x_3} = 0. \quad (8.23.4)$$

Differentiating the preceding three equations with respect to x_1 and interchanging the order of differentiations, we get

$$\frac{\partial}{\partial x_1} \frac{\partial p}{\partial x_1} = \frac{\partial}{\partial x_2} \frac{\partial p}{\partial x_1} = \frac{\partial}{\partial x_3} \frac{\partial p}{\partial x_1} = 0. \quad (8.23.5)$$

Thus, $\partial p / \partial x_1$, the driving force of the flow, is independent of the coordinates. Let this driving force be denoted by f , that is,

$$-\frac{\partial p}{\partial x_1} \equiv f, \quad (8.23.6)$$

then we have $\frac{d\tau}{dx_2} = -f$ so that

$$\tau(k(x_2)) = -fx_2, \quad (8.23.7)$$

where the integration constant is taken to be zero because the flow is symmetric with respect to the plane $x_2 = 0$ [see boundary conditions (8.23.2)]. Inverting Eq. (8.23.7), we have

$$k = \gamma(-fx_2) \equiv -\gamma(fx_2), \quad (8.23.8)$$

where $\gamma(s)$, the inverse function of $\tau(k)$, is an odd function because $\tau(k)$ is an odd function. Now $k(x_2) \equiv dv/dx_2$; therefore, the preceding equation gives

$$\frac{dv}{dx_2} = -\gamma(fx_2). \quad (8.23.9)$$

Integrating, we get

$$v(x_2) = - \int_{-h/2}^{x_2} \gamma(fx_2) dx_2. \quad (8.23.10)$$

For a given simple fluid with a known shear stress function $\tau(k)$, $\gamma(S)$ is also known, the preceding equation can be integrated to give the velocity distribution in the channel. The volume flux per unit width, Q , is given by

$$Q = \int_{-h/2}^{h/2} v(x_2) dx_2. \quad (8.23.11)$$

Equation (8.23.11) can be written in a form suitable for determining the function $\gamma(S)$ from an experimentally measured relationship between Q and f . Indeed, integration by parts gives

$$Q = x_2 v(x_2) \Big|_{-h/2}^{h/2} - \int_{-h/2}^{h/2} x_2 \left(\frac{dv}{dx_2} \right) dx_2 = - \int_{-h/2}^{h/2} x_2 \left(\frac{dv}{dx_2} \right) dx_2. \quad (8.23.12)$$

Using Eq. (8.23.9), we obtain

$$Q = \int_{-h/2}^{h/2} x_2 \gamma(fx_2) dx_2 = \frac{1}{f^2} \int_{S=-fh/2}^{fh/2} S \gamma(S) dS. \quad (8.23.13)$$

or

$$Q = \frac{2}{f^2} \int_{S=0}^{fh/2} S \gamma(S) dS. \quad (8.23.14)$$

Thus,

$$\frac{\partial f^2 Q}{\partial f} = 2 \frac{\partial}{\partial f} \int_{S=0}^{fh/2} S \gamma(S) dS = 2 \left\{ \int_{S=0}^{fh/2} 0 dS + [S \gamma(S)]_{S=fh/2} \frac{\partial}{\partial f} \left(\frac{fh}{2} \right) - 0 \right\}. \quad (8.23.15)$$

That is,

$$\frac{\partial f^2 Q}{\partial f} = 2 \left(\frac{fh}{2} \right) \left[\gamma \left(\frac{fh}{2} \right) \right] \left(\frac{h}{2} \right) = \frac{fh^2}{2} \gamma \left(\frac{fh}{2} \right). \quad (8.23.16)$$

or

$$\gamma \left(\frac{fh}{2} \right) = \frac{2}{fh^2} \frac{\partial (f^2 Q)}{\partial f}. \quad (8.23.17)$$

Now, if the variation of Q with the driving force f (the pressure gradient $-\partial p/\partial x_1$) is measured experimentally, then the right-hand side of the preceding equation is known so that the inverse shear stress function $\gamma(S)$ can be obtained from the preceding equation.

Example 8.23.1

For a Newtonian fluid, (a) use Eq. (8.23.10) to calculate the velocity profile in the channel, and (b) use Eq. (8.23.14) to calculate the volume discharge per unit width across a cross-section of the channel.

Solution

For a Newtonian fluid,

$$\tau(k) = \mu k. \quad (8.23.18)$$

The inverse of this equation is

$$k = \gamma(\tau) = \frac{\tau}{\mu} \quad \text{or} \quad \gamma(S) = \frac{S}{\mu}. \quad (8.23.19)$$

Thus, $\gamma(fx_2) = \frac{fx_2}{\mu}$ and Eq. (8.23.10) gives

$$v(x_2) = - \int_{-h/2}^{x_2} \gamma(fx_2) dx_2 = - \frac{f}{\mu} \int_{-h/2}^{x_2} x_2 dx_2 = - \frac{f}{\mu} \left[\frac{x_2^2}{2} \right]_{-h/2}^{x_2} = - \frac{f}{\mu} \left(\frac{x_2^2}{2} - \frac{h^2}{8} \right), \quad (8.23.20)$$

and from Eq. (8.23.14),

$$Q = \frac{2}{f^2} \int_{S=0}^{fh/2} S \gamma(S) dS = \frac{2}{f^2} \int_{S=0}^{fh/2} S \left(\frac{S}{\mu} \right) dS = \frac{2}{\mu f^2} \int_{S=0}^{fh/2} S^2 dS = \frac{fh^3}{12\mu}. \quad (8.23.21)$$

These results are, of course, the same as those obtained in Chapter 6 for the plane Poiseuille flow.

8.24 COUETTE FLOW

Couette flow is defined as the two-dimensional steady laminar flow between two concentric infinitely long cylinders that rotate with angular velocities Ω_1 and Ω_2 . The velocity field is given by

$$v_r = 0, \quad v_\theta = v(r) = r\omega(r), \quad v_z = 0. \quad (8.24.1)$$

In Example 8.21.3, we see that the Couette flow is a viscometric flow, and with $\{\mathbf{n}_1, \mathbf{n}_2, \mathbf{n}_3\} \equiv \{\mathbf{e}_\theta, \mathbf{e}_r, \mathbf{e}_z\}$, the nonzero Rivlin-Ericksen tensors are given by

$$[\mathbf{A}_1] = \begin{bmatrix} 0 & k(r) & 0 \\ k(r) & 0 & 0 \\ 0 & 0 & 0 \end{bmatrix}_{\{\mathbf{n}_1, \mathbf{n}_2, \mathbf{n}_3\}}, \quad [\mathbf{A}_2] = \begin{bmatrix} 0 & 0 & 0 \\ 0 & 2k^2(r) & 0 \\ 0 & 0 & 0 \end{bmatrix}_{\{\mathbf{n}_1, \mathbf{n}_2, \mathbf{n}_3\}}, \quad (8.24.2)$$

where

$$k(r) = \frac{dv}{dr} - \frac{v}{r} = \frac{rd\omega}{dr}. \quad (8.24.3)$$

Thus, the stress components with respect to $\{\mathbf{n}_1, \mathbf{n}_2, \mathbf{n}_3\} \equiv \{\mathbf{e}_\theta, \mathbf{e}_r, \mathbf{e}_z\}$ are given by (see Section 8.21)

$$T_{\theta r} = S_{\theta r} \equiv \tau(k), \quad T_{\theta\theta} = -p + S_{\theta\theta}(k), \quad T_{rr} = -p + S_{rr}(k), \quad T_{zz} = -p + S_{zz}(k), \quad (8.24.4)$$

and

$$T_{\theta z} = T_{z\theta} = T_{zr} = T_{rz} \equiv 0. \quad (8.24.5)$$

The shear stress function is $\tau(k)$ and the normal stress functions are

$$\sigma_1 = T_{\theta\theta} - T_{rr}, \quad \sigma_2 = T_{rr} - T_{zz}. \quad (8.24.6)$$

These three functions completely characterize the fluid in any viscometric flow, of which the Couette flow is one. For a given simple fluid, these three functions are assumed to be known. On the other hand, we may use any one of the viscometric flows to measure these functions for use with the same fluid in other viscometric flows.

Let us first assume that we know these functions; then our objective is to find the velocity distribution $v(r)$ and the stress distribution $T_{ij}(r)$ in this flow when the externally applied torque M per unit height in the axial direction is given.

In the absence of body forces, the equations of motion for the Couette flow, where nothing depends on θ , are

$$\frac{dT_{rr}}{dr} + \frac{T_{rr} - T_{\theta\theta}}{r} = -\rho r\omega^2, \quad \left(\frac{dT_{r\theta}}{dr} + \frac{2T_{r\theta}}{r}\right) = 0, \quad -\frac{\partial p}{\partial z} = 0. \quad (8.24.7)$$

From the second of the preceding equation, we have

$$\begin{aligned} \frac{dT_{r\theta}}{dr} + \frac{2T_{r\theta}}{r} &= \frac{1}{r^2} \frac{d}{dr} (r^2 T_{r\theta}) = 0, \text{ thus} \\ T_{r\theta} &= \frac{C}{r^2}, \end{aligned} \quad (8.24.8)$$

where C is the integration constant. The torque per unit height of the cylinders needed to maintain the flow is given by

$$M = (2\pi r T_{r\theta})r. \quad (8.24.9)$$

Thus, $C = M/2\pi$ and

$$\tau(k) \equiv T_{r\theta} = \frac{M}{2\pi r^2}, \quad k(r) = r \frac{d\omega}{dr}. \quad (8.24.10)$$

We wish to find the velocity distribution $v(r)$ from the known shear stress function $\tau(k)$. To do this, we let

$$S(r) = \tau(k(r)) \quad \text{and} \quad k(r) = \gamma(S), \quad (8.24.11)$$

where $\gamma(S)$ is the inverse of the function $\tau(k)$. From Eqs. (8.24.10) and (8.24.11), we have

$$r \frac{d\omega}{dr} = \gamma(S), \quad S = \frac{M}{2\pi r^2}. \quad (8.24.12)$$

Now

$$\frac{d\omega}{dr} = \frac{d\omega}{dS} \frac{dS}{dr} = \frac{d\omega}{dS} \left(-\frac{M}{\pi r^3} \right) = -\frac{d\omega}{dS} \left(\frac{2S}{r} \right),$$

thus,

$$\gamma(S) = r \frac{d\omega}{dr} = -2S \frac{d\omega}{dS}, \quad (8.24.13)$$

from which we get

$$d\omega = -\frac{\gamma(S)}{2S} dS. \quad (8.24.14)$$

Integration of the preceding equation gives

$$\int_{\Omega_1}^{\omega} d\omega = - \int_{M/2\pi R_1^2}^{M/2\pi r^2} \left(\frac{\gamma(S)}{2S} \right) dS. \quad (8.24.15)$$

That is,

$$\omega - \Omega_1 = - \int_{M/2\pi R_1^2}^{M/2\pi r^2} \frac{\gamma(S)}{2S} dS, \quad (8.24.16)$$

and

$$\Delta\Omega \equiv \Omega_2 - \Omega_1 = - \int_{M/2\pi R_1^2}^{M/2\pi R_2^2} \frac{\gamma(S)}{2S} dS, \quad (8.24.17)$$

where Ω_1 and Ω_2 are the angular velocity of the inner cylinder (radius R_1) and outer cylinder (radius R_2). For a given material function $\gamma(S)$, the applied torque M , the angular velocity of the inner cylinder Ω_1 , and the radii of the cylinders R_1 and R_2 , the preceding equations allow us to calculate Ω_2 and $\omega(r)$, from which we can calculate $v_\theta(r) = r\omega(r)$.

Next, we calculate the normal stresses T_{rr} at the two cylindrical surfaces $r = R_1$ and $r = R_2$. From the r -equation of motion in Eq. (8.24.7), we have, with $\sigma_1 \equiv T_{\theta\theta} - T_{rr}$ denoting the normal stress function of the fluid

$$\frac{dT_{rr}}{dr} - \frac{\sigma_1}{r} = -\rho r \omega^2. \quad (8.24.18)$$

Integration of the preceding equation gives

$$T_{rr}(r) - T_{rr}(R_1) = \int_{R_1}^r \frac{\sigma_1}{r} dr - \rho \int_{R_1}^r r \omega^2 dr. \quad (8.24.19)$$

We now calculate the difference between the *compressive* normal stress on the outer cylinder ($r = R_2$) and the inner cylinder ($r = R_1$). That is,

$$[-T_{rr}(R_2)] - [-T_{rr}(R_1)] = \rho \int_{R_1}^{R_2} r \omega^2 dr - \int_{R_1}^{R_2} \frac{\sigma_1}{r} dr. \quad (8.24.20)$$

On the right-hand side of the preceding equation, the first term is always positive, stating that the centrifugal force effects always make the pressure on the outer cylinder larger than that on the inner cylinder. On the other hand, for a fluid with a positive normal stress function σ_1 , the second term in the preceding equation is negative, stating that the contribution to the pressure difference due to the normal stress effect is in the opposite direction to that due to the centrifugal force effect. Indeed, all known polymeric solutions have a positive σ_1 and in many instances, this normal stress effect actually causes the pressure on the inner cylinder to be larger than that on the outer cylinder.

We now consider the reverse problem of determining the material function $\gamma(S)$ from a measured relationship between the torque M needed to maintain the Couette flow and the angular velocity difference $\Delta\Omega = \Omega_2 - \Omega_1$. Once $\gamma(S)$ is obtained, its inverse then gives the shear stress function $\tau(S)$.

From Eq. (8.24.17), that is,

$$\Delta\Omega = - \int_{M/2\pi R_1^2}^{M/2\pi R_2^2} \frac{\gamma(S)}{2S} dS,$$

we obtain, with $S_1 = M/2\pi R_1^2$ and $S_2 = M/2\pi R_2^2$,

$$-\frac{\partial\Delta\Omega}{\partial M} = \left[\frac{\gamma(S_2)}{2S_2} \right] \left(\frac{1}{2\pi R_2^2} \right) - \left[\frac{\gamma(S_1)}{2S_1} \right] \left(\frac{1}{2\pi R_1^2} \right) = \frac{\gamma(S_2)}{2M} - \frac{\gamma(S_1)}{2M}.$$

That is,

$$2M \frac{\partial\Delta\Omega}{\partial M} = \gamma(S_1) - \gamma(S_2). \quad (8.24.21)$$

Let

$$S_2 \equiv \beta S_1 \quad \text{and} \quad \Gamma(S_1) \equiv \gamma(S_1) - \gamma(\beta S_1), \quad (8.24.22)$$

then Eq. (8.24.21) becomes

$$2M \frac{\partial\Delta\Omega}{\partial M} = \Gamma(S_1), \quad S_1 = \frac{M}{2\pi R_1^2}. \quad (8.24.23)$$

Equation (8.24.23) allows the determination of $\Gamma(S_1)$ from experimental results relating $\Delta\Omega$ with M . To obtain $\gamma(S)$, we note from $\Gamma(S_1) = \gamma(S_1) - \gamma(\beta S_1)$; we obtain

$$\Gamma(\beta S_1) = \gamma(\beta S_1) - \gamma(\beta^2 S_1), \quad \Gamma(\beta^2 S_1) = \gamma(\beta^2 S_1) - \gamma(\beta^3 S_1), \dots$$

Thus, summing all these equations, we get

$$\sum_{n=0}^N \Gamma(\beta^n S_1) = \gamma(S_1) - \gamma(\beta S_1) + \gamma(\beta S_1) - \gamma(\beta^2 S_1) + \gamma(\beta^2 S_1) - \dots - \gamma(\beta^{N+1} S_1). \quad (8.24.24)$$

Thus,

$$\sum_{n=0}^N \Gamma(\beta^n S_1) = \gamma(S_1) - \gamma(\beta^{N+1} S_1). \quad (8.24.25)$$

Since $\beta \equiv S_2/S_1 = R_1^2/R_2^2 < 1$, as $N \rightarrow \infty$, $\beta^N \rightarrow 0$. Thus,

$$\gamma(S_1) = \sum_{n=0}^{\infty} \Gamma(\beta^n S_1). \quad (8.24.26)$$

From experimentally determined $\Gamma(S)$ [see Eq. (8.24.23)], the preceding equation allows us to obtain $\gamma(S)$ from which the shear stress function $\tau(k)$ can be obtained [see Eq. (8.24.11)].

If the gap $R_2 - R_1$ is very small, the rate of shear k will essentially be a constant independent of r and is given by

$$k = \frac{R_1 \Delta\Omega}{R_2 - R_1}. \quad (8.24.27)$$

Thus, $k = \gamma(S_1)$ leads to

$$\gamma\left(\frac{M}{2\pi R_1^2}\right) = \frac{R_1 \Delta\Omega}{R_2 - R_1}. \quad (8.24.28)$$

By measuring the relationship between M and $\Delta\Omega$, the preceding equation determines the inverse shear stress function $\gamma(S)$.

APPENDIX 8.1: GRADIENT OF SECOND-ORDER TENSOR FOR ORTHOGONAL COORDINATES

In the following derivations, tensors will be expressed in terms of dyadic products $\mathbf{e}_i \mathbf{e}_j$ and $\mathbf{e}_i \mathbf{e}_j \mathbf{e}_k$ of base vectors. That is,

Second-order tensor \mathbf{T} : $\mathbf{T} = T_{ij} \mathbf{e}_i \mathbf{e}_j$ and $\mathbf{T} \mathbf{e}_m = T_{jm} \mathbf{e}_j$.

Third-order tensor \mathbf{M} : $\mathbf{M} = M_{ijk} \mathbf{e}_i \mathbf{e}_j \mathbf{e}_k$ and $\mathbf{M} \mathbf{e}_n = M_{ijn} \mathbf{e}_i \mathbf{e}_j$.

A. Polar Coordinates with Basis $\{\mathbf{e}_r, \mathbf{e}_\theta\}$

Let

$$\mathbf{T}(r, \theta) = T_{rr} \mathbf{e}_r \mathbf{e}_r + T_{r\theta} \mathbf{e}_r \mathbf{e}_\theta + T_{\theta r} \mathbf{e}_\theta \mathbf{e}_r + T_{\theta\theta} \mathbf{e}_\theta \mathbf{e}_\theta. \quad (8A.1)$$

By definition of $\nabla \mathbf{T}$, we have

$$d\mathbf{T} = \nabla \mathbf{T} d\mathbf{r} \equiv \mathbf{M} d\mathbf{r}, \quad (8A.2)$$

where \mathbf{M} denotes the gradient of \mathbf{T} , which is a third-order tensor. In polar coordinates,

$$d\mathbf{T} = \mathbf{M} d\mathbf{r} = \mathbf{M}(d\mathbf{r}_e + r d\theta \mathbf{e}_\theta) = dr(\mathbf{M} \mathbf{e}_r) + r d\theta(\mathbf{M} \mathbf{e}_\theta). \quad (8A.3)$$

Now

$$\mathbf{M} \mathbf{e}_r = M_{rrr} \mathbf{e}_r \mathbf{e}_r + M_{r\theta r} \mathbf{e}_r \mathbf{e}_\theta + M_{\theta rr} \mathbf{e}_\theta \mathbf{e}_r + M_{\theta\theta r} \mathbf{e}_\theta \mathbf{e}_\theta, \quad (8A.4)$$

$$\mathbf{M} \mathbf{e}_\theta = M_{rr\theta} \mathbf{e}_r \mathbf{e}_r + M_{r\theta\theta} \mathbf{e}_r \mathbf{e}_\theta + M_{\theta r\theta} \mathbf{e}_\theta \mathbf{e}_r + M_{\theta\theta\theta} \mathbf{e}_\theta \mathbf{e}_\theta,$$

therefore,

$$\begin{aligned} d\mathbf{T} &= (M_{rrr} dr + M_{r\theta r} r d\theta) \mathbf{e}_r \mathbf{e}_r + (M_{r\theta r} dr + M_{r\theta\theta} r d\theta) \mathbf{e}_r \mathbf{e}_\theta \\ &\quad + (M_{\theta rr} dr + M_{\theta r\theta} r d\theta) \mathbf{e}_\theta \mathbf{e}_r + (M_{\theta\theta r} dr + M_{\theta\theta\theta} r d\theta) \mathbf{e}_\theta \mathbf{e}_\theta. \end{aligned} \quad (8A.5)$$

We also have, from Eq. (8A.1),

$$\begin{aligned} d\mathbf{T}(r, \theta) &= dT_{rr} \mathbf{e}_r \mathbf{e}_r + T_{rr} (d\mathbf{e}_r) \mathbf{e}_r + T_{rr} \mathbf{e}_r (d\mathbf{e}_r) + dT_{r\theta} \mathbf{e}_r \mathbf{e}_\theta + T_{r\theta} (d\mathbf{e}_r) \mathbf{e}_\theta + T_{r\theta} \mathbf{e}_r (d\mathbf{e}_\theta) \\ &\quad + dT_{\theta r} \mathbf{e}_\theta \mathbf{e}_r + T_{\theta r} (d\mathbf{e}_\theta) \mathbf{e}_r + T_{\theta r} \mathbf{e}_\theta (d\mathbf{e}_r) + dT_{\theta\theta} \mathbf{e}_\theta \mathbf{e}_\theta + T_{\theta\theta} (d\mathbf{e}_\theta) \mathbf{e}_\theta + T_{\theta\theta} \mathbf{e}_\theta (d\mathbf{e}_\theta). \end{aligned} \quad (8A.6)$$

Since

$$d\mathbf{e}_r = d\theta\mathbf{e}_\theta, \quad d\mathbf{e}_\theta = -d\theta\mathbf{e}_r, \quad (8A.7)$$

Eq. (8A.6) becomes

$$\begin{aligned} d\mathbf{T}(r, \theta) = & (dT_{rr} - T_{\theta r}d\theta - T_{r\theta}d\theta)\mathbf{e}_r\mathbf{e}_r + (dT_{r\theta} + T_{rr}d\theta - T_{\theta\theta}d\theta)\mathbf{e}_r\mathbf{e}_\theta \\ & + (dT_{\theta r} + T_{rr}d\theta - T_{\theta\theta}d\theta)\mathbf{e}_\theta\mathbf{e}_r + (dT_{\theta\theta} + T_{\theta r}d\theta + T_{r\theta}d\theta)\mathbf{e}_\theta\mathbf{e}_\theta. \end{aligned} \quad (8A.8)$$

Now, from calculus,

$$dT_{ij} = \frac{\partial T_{ij}}{\partial r} dr + \frac{\partial T_{ij}}{\partial \theta} d\theta. \quad (8A.9)$$

Substituting Eq. (8A.9) into Eq. (8A.8), we have

$$\begin{aligned} d\mathbf{T}(r, \theta) = & \left[\frac{\partial T_{rr}}{\partial r} dr + \left(\frac{\partial T_{rr}}{\partial \theta} - T_{\theta r} - T_{r\theta} \right) d\theta \right] \mathbf{e}_r\mathbf{e}_r + \left[\frac{\partial T_{r\theta}}{\partial r} dr + \left(\frac{\partial T_{r\theta}}{\partial \theta} + T_{rr} - T_{\theta\theta} \right) d\theta \right] \mathbf{e}_r\mathbf{e}_\theta \\ & + \left[\frac{\partial T_{\theta r}}{\partial r} dr + \left(\frac{\partial T_{\theta r}}{\partial \theta} + T_{rr} - T_{\theta\theta} \right) d\theta \right] \mathbf{e}_\theta\mathbf{e}_r + \left[\frac{\partial T_{\theta\theta}}{\partial r} dr + \left(\frac{\partial T_{\theta\theta}}{\partial \theta} + T_{\theta r} + T_{r\theta} \right) d\theta \right] \mathbf{e}_\theta\mathbf{e}_\theta. \end{aligned} \quad (8A.10)$$

Comparing Eq. (8A.10) with Eq. (8A.5), we have

$$\begin{aligned} M_{rrr} &= \frac{\partial T_{rr}}{\partial r}, \quad M_{rr\theta} = \left(\frac{1}{r} \frac{\partial T_{rr}}{\partial \theta} - \frac{T_{\theta r} + T_{r\theta}}{r} \right), \quad M_{r\theta r} = \frac{\partial T_{r\theta}}{\partial r}, \\ M_{r\theta\theta} &= \left(\frac{1}{r} \frac{\partial T_{r\theta}}{\partial \theta} + \frac{T_{rr} - T_{\theta\theta}}{r} \right), \quad M_{\theta rr} = \frac{\partial T_{\theta r}}{\partial r}, \quad M_{\theta r\theta} = \left(\frac{1}{2} \frac{\partial T_{\theta r}}{\partial \theta} + \frac{T_{rr} - T_{\theta\theta}}{r} \right), \\ M_{\theta\theta r} &= \frac{\partial T_{\theta\theta}}{\partial r}, \quad M_{\theta\theta\theta} = \left(\frac{1}{r} \frac{\partial T_{\theta\theta}}{\partial \theta} + \frac{T_{\theta r} + T_{r\theta}}{r} \right). \end{aligned} \quad (8A.11)$$

B. Cylindrical Coordinates with Basis $\{\mathbf{e}_r, \mathbf{e}_\theta, \mathbf{e}_z\}$ and Spherical Coordinates with Basis $\{\mathbf{e}_r, \mathbf{e}_\theta, \mathbf{e}_\phi\}$:

In general, we can write

$$d\mathbf{e}_i = \Gamma_{ijk} dx_j \mathbf{e}_k, \quad (8A.12)$$

where the values of Γ_{ijk} depend on the particular coordinate system. For example:

For a cylindrical coordinate system:

$$d\mathbf{e}_r = d\theta\mathbf{e}_\theta, \quad d\mathbf{e}_\theta = -d\theta\mathbf{e}_r, \quad d\mathbf{e}_z = 0,$$

therefore,

$$\Gamma_{r\theta\theta} = 1, \quad \Gamma_{\theta\theta r} = -1, \quad \text{all other } \Gamma_{ijk} = 0. \quad (8A.13)$$

For a spherical coordinate system:

$$d\mathbf{e}_r = d\theta\mathbf{e}_\theta + \sin\theta d\phi\mathbf{e}_\phi, \quad d\mathbf{e}_\theta = -d\theta\mathbf{e}_r + \cos\theta d\phi\mathbf{e}_\phi, \quad d\mathbf{e}_\phi = -\sin\theta d\phi\mathbf{e}_r - \cos\theta d\phi\mathbf{e}_\theta,$$

therefore, the nonzero Γ_{ijk} are

$$\begin{aligned} \Gamma_{r\theta\theta} &= 1, & \Gamma_{r\phi\phi} &= \sin\theta, & \Gamma_{\phi\phi r} &= -\sin\theta, & \Gamma_{\phi\phi\theta} &= -\cos\theta, \\ \Gamma_{\theta\theta r} &= -1, & \Gamma_{\theta\phi\phi} &= \cos\theta \end{aligned} \quad (8A.14)$$

Let $\nabla\mathbf{T}$ denote the gradient of the second-order tensor \mathbf{T} ; then, by definition,

$$d\mathbf{T} = \nabla\mathbf{T}d\mathbf{r} \equiv \mathbf{M}d\mathbf{r}, \quad (8A.15)$$

where $\mathbf{M} \equiv \nabla\mathbf{T}$ is a third-order tensor. In general,

$$d\mathbf{r} = \sum_{m=1}^3 h_m dx_m \mathbf{e}_m, \quad (8A.16)$$

where for cylindrical coordinates (r, θ, z) , $h_r = 1$, $h_\theta = r$, $h_z = 1$ and for spherical coordinates (r, θ, ϕ) , $h_r = 1$, $h_\theta = r$, $h_\phi = r \sin\theta$. Thus,

$$d\mathbf{T} = \mathbf{M}d\mathbf{r} = \mathbf{M} \sum_{m=1}^3 h_m dx_m \mathbf{e}_m = \sum_{m=1}^3 [h_m dx_m (\mathbf{M}\mathbf{e}_m)] = \sum_{m=1}^3 [h_m dx_m (\mathbf{M}\mathbf{e}_m)]. \quad (8A.17)$$

Now, \mathbf{M} is a third-order tensor so that $\mathbf{M}\mathbf{e}_i$ is a second-order tensor given by

$$(\mathbf{M}\mathbf{e}_i) = M_{mni} \mathbf{e}_m \mathbf{e}_n, \quad (8A.18)$$

therefore,

$$d\mathbf{T} = \sum_{m=1}^3 [h_m dx_m (\mathbf{M}\mathbf{e}_m)] = \sum_{m=1}^3 [h_m M_{ijm} dx_m \mathbf{e}_i \mathbf{e}_j]. \quad (8A.19)$$

From $\mathbf{T} = T_{ij} \mathbf{e}_i \mathbf{e}_j$, we have

$$d\mathbf{T} = dT_{ij} \mathbf{e}_i \mathbf{e}_j + T_{ij} d\mathbf{e}_i \mathbf{e}_j + T_{ij} \mathbf{e}_i d\mathbf{e}_j = dT_{ij} \mathbf{e}_i \mathbf{e}_j + T_{qj} d\mathbf{e}_q \mathbf{e}_j + T_{ij} \mathbf{e}_i d\mathbf{e}_j. \quad (8A.20)$$

With

$$d\mathbf{e}_q = \Gamma_{qpi} dx_p \mathbf{e}_i = \Gamma_{qpi} dx_p \mathbf{e}_i, \quad (8A.21)$$

we have

$$d\mathbf{T} = (dT_{ij} + T_{qj} \Gamma_{qpi} dx_p + T_{iq} \Gamma_{qpi} dx_p) \mathbf{e}_i \mathbf{e}_j. \quad (8A.22)$$

Now, from calculus,

$$dT_{ij} = (\partial T_{ij} / \partial x_m) dx_m. \quad (8A.23)$$

Substituting Eq. (8A.9) into Eq. (8A.8), we have

$$d\mathbf{T} = [(\partial T_{ij} / \partial x_m + T_{qj} \Gamma_{qmi} + T_{iq} \Gamma_{qmi}) dx_m] \mathbf{e}_i \mathbf{e}_j. \quad (8A.24)$$

Comparing Eq. (8A.10) with Eq. (8A.5), we have

$$d\mathbf{T} = \sum_{m=1}^3 [M_{ijm} h_m dx_m] = \sum_{m=1}^3 (\partial T_{ij} / \partial x_m + T_{qj} \Gamma_{qmi} + T_{iq} \Gamma_{qmi}) dx_m. \quad (8A.25)$$

Thus,

$$M_{ijm}h_m = \frac{\partial T_{ij}}{\partial x_m} + T_{qj}\Gamma_{qmi} + T_{iq}\Gamma_{qmj} \quad \text{no sum on } m, \text{ sum on } q. \quad (8A.26)$$

In the following, the preceding equation is used to obtain the components for the third-order tensor $\nabla \mathbf{T}$ for cylindrical and spherical coordinates.

B.1. Cylindrical Coordinates

		r	θ	z
Table A8.1 $(\nabla T)_{ijm}h_m = \frac{\partial T_{ij}}{\partial x_m} + T_{qj}\Gamma_{qmi} + T_{iq}\Gamma_{qmj}$ no sum on m , sum on q . $h_r = 1, h_\theta = r, h_z = 1; \Gamma_{r\theta\theta} = 1, \Gamma_{\theta\theta r} = -1$, all other $\Gamma_{ijk} = 0$.				
r	r	$(\nabla \mathbf{T})_{rrr} = \frac{\partial T_{rr}}{\partial r}$	$(\nabla \mathbf{T})_{rr\theta} = \left[\frac{1}{r} \frac{\partial T_{rr}}{\partial \theta} - \frac{T_{\theta r} + T_{r\theta}}{r} \right]$	$(\nabla \mathbf{T})_{rrz} = \frac{\partial T_{rr}}{\partial z}$
	θ	$(\nabla \mathbf{T})_{r\theta r} = \frac{\partial T_{r\theta}}{\partial r}$	$(\nabla \mathbf{T})_{r\theta\theta} = \frac{1}{r} \frac{\partial T_{r\theta}}{\partial \theta} + \frac{T_{rr} - T_{\theta\theta}}{r}$	$(\nabla \mathbf{T})_{r\theta z} = \frac{\partial T_{r\theta}}{\partial z}$
	z	$(\nabla \mathbf{T})_{r zr} = \frac{\partial T_{rz}}{\partial r}$	$(\nabla \mathbf{T})_{r z\theta} = \frac{1}{r} \frac{\partial T_{rz}}{\partial \theta} - \frac{T_{\theta z}}{r}$	$(\nabla \mathbf{T})_{rzz} = \frac{\partial T_{rz}}{\partial z}$
θ	r	$(\nabla \mathbf{T})_{\theta rr} = \frac{\partial T_{\theta r}}{\partial r}$	$(\nabla \mathbf{T})_{\theta r\theta} = \frac{1}{r} \frac{\partial T_{\theta r}}{\partial \theta} + \frac{T_{rr} - T_{\theta\theta}}{r}$	$(\nabla \mathbf{T})_{\theta rz} = \frac{\partial T_{\theta r}}{\partial z}$
	θ	$(\nabla \mathbf{T})_{\theta\theta r} = \frac{\partial T_{\theta\theta}}{\partial r}$	$(\nabla \mathbf{T})_{\theta\theta\theta} = \frac{1}{r} \frac{\partial T_{\theta\theta}}{\partial \theta} + \frac{T_{r\theta} + T_{\theta r}}{r}$	$(\nabla \mathbf{T})_{\theta\theta z} = \frac{\partial T_{\theta\theta}}{\partial z}$
	z	$(\nabla \mathbf{T})_{\theta zr} = \frac{\partial T_{\theta z}}{\partial r}$	$(\nabla \mathbf{T})_{\theta z\theta} = \frac{1}{r} \frac{\partial T_{\theta z}}{\partial \theta} + \frac{T_{rz}}{r}$	$(\nabla \mathbf{T})_{\theta zz} = \frac{\partial T_{\theta z}}{\partial z}$
z	r	$(\nabla \mathbf{T})_{zrr} = \frac{\partial T_{zr}}{\partial r}$	$(\nabla \mathbf{T})_{zr\theta} = \frac{1}{r} \frac{\partial T_{zr}}{\partial \theta} - \frac{T_{z\theta}}{r}$	$(\nabla \mathbf{T})_{zrz} = \frac{\partial T_{zr}}{\partial z}$
	θ	$(\nabla \mathbf{T})_{z\theta r} = \frac{\partial T_{z\theta}}{\partial r}$	$(\nabla \mathbf{T})_{z\theta\theta} = \frac{1}{r} \frac{\partial T_{z\theta}}{\partial \theta} + \frac{T_{zr}}{r}$	$(\nabla \mathbf{T})_{z\theta z} = \frac{\partial T_{z\theta}}{\partial z}$
	z	$(\nabla \mathbf{T})_{z zr} = \frac{\partial T_{zz}}{\partial r}$	$(\nabla \mathbf{T})_{z z\theta} = \frac{1}{r} \frac{\partial T_{zz}}{\partial \theta}$	$(\nabla \mathbf{T})_{z zz} = \frac{\partial T_{zz}}{\partial z}$

From Table A8.1, we can also obtain the divergence of a second-order \mathbf{T} as

$$(\text{div } \mathbf{T})_r = (\nabla \mathbf{T})_{rrr} + (\nabla \mathbf{T})_{r\theta\theta} + (\nabla \mathbf{T})_{rzz} = \frac{\partial T_{rr}}{\partial r} + \frac{1}{r} \frac{\partial T_{r\theta}}{\partial \theta} + \frac{T_{rr} - T_{\theta\theta}}{r} + \frac{\partial T_{rz}}{\partial z}, \quad (8A.27)$$

$$(\text{div } \mathbf{T})_\theta = (\nabla \mathbf{T})_{\theta rr} + (\nabla \mathbf{T})_{\theta\theta\theta} + (\nabla \mathbf{T})_{\theta zz} = \frac{\partial T_{\theta r}}{\partial r} + \frac{1}{r} \frac{\partial T_{\theta\theta}}{\partial \theta} + \frac{T_{r\theta} + T_{\theta r}}{r} + \frac{\partial T_{\theta z}}{\partial z}, \quad (8A.28)$$

$$(\text{div } \mathbf{T})_z = (\nabla \mathbf{T})_{zrr} + (\nabla \mathbf{T})_{z\theta\theta} + (\nabla \mathbf{T})_{z zz} = \frac{\partial T_{zr}}{\partial r} + \frac{1}{r} \frac{\partial T_{z\theta}}{\partial \theta} + \frac{T_{zr}}{r} + \frac{\partial T_{zz}}{\partial z}. \quad (8A.29)$$

We note that these equations for $\text{div } \mathbf{T}$ are the same as those obtained in Chapter 2 by using a different method.

B.2. Spherical Coordinates

Table A8.2 $(\nabla \mathbf{T})_{ijm} h_m = \frac{\partial T_{ij}}{\partial x_m} + T_{qj} \Gamma_{qmi} + T_{iq} \Gamma_{qmj}$ no sum on m , sum on q ,

$$h_r = 1, h_\theta = r, h_\phi = r \sin \theta; \Gamma_{r\theta\theta} = 1, \Gamma_{r\phi\phi} = \sin \theta,$$

$$\Gamma_{\phi\phi r} = -\sin \theta, \Gamma_{\phi\phi\theta} = -\cos \theta, \Gamma_{\theta\theta r} = -1, \Gamma_{\theta\phi\phi} = \cos \theta \text{ all other } \Gamma_{ijk} = 0.$$

		r	θ	ϕ
r	r	$\frac{\partial T_{rr}}{\partial r}$	$\frac{1}{r} \frac{\partial T_{rr}}{\partial \theta} - \frac{T_{\theta r} + T_{r\theta}}{r}$	$\frac{1}{r \sin \theta} \frac{\partial T_{rr}}{\partial \phi} - \frac{(T_{\phi r} + T_{r\phi})}{r}$
	θ	$\frac{\partial T_{r\theta}}{\partial r}$	$\frac{1}{r} \frac{\partial T_{r\theta}}{\partial \theta} + \frac{T_{rr} - T_{\theta\theta}}{r}$	$\frac{1}{r \sin \theta} \frac{\partial T_{r\theta}}{\partial \phi} - \frac{T_{\phi\theta} + T_{r\phi} \cot \theta}{r}$
	ϕ	$\frac{\partial T_{r\phi}}{\partial r}$	$\frac{1}{r} \frac{\partial T_{r\phi}}{\partial \theta} - \frac{T_{\theta\phi}}{r}$	$\frac{1}{r \sin \theta} \frac{\partial T_{r\phi}}{\partial \phi} + \frac{T_{rr} - T_{\phi\phi}}{r} + \frac{T_{r\theta} \cot \theta}{r}$
θ	r	$\frac{\partial T_{\theta r}}{\partial r}$	$\frac{1}{r} \frac{\partial T_{\theta r}}{\partial \theta} + \frac{T_{rr} - T_{\theta\theta}}{r}$	$\frac{1}{r \sin \theta} \frac{\partial T_{\theta r}}{\partial \phi} - \frac{T_{\phi r} \cot \theta}{r} - \frac{T_{\theta\phi}}{r}$
	θ	$\frac{\partial T_{\theta\theta}}{\partial r}$	$\frac{1}{r} \frac{\partial T_{\theta\theta}}{\partial \theta} + \frac{T_{r\theta} + T_{\theta r}}{r}$	$\frac{1}{r \sin \theta} \frac{\partial T_{\theta\theta}}{\partial \phi} - \frac{(T_{\phi\theta} + T_{\theta\phi}) \cot \theta}{r}$
	ϕ	$\frac{\partial T_{\theta\phi}}{\partial r}$	$\frac{1}{r} \frac{\partial T_{\theta\phi}}{\partial \theta} + \frac{T_{r\phi}}{r}$	$\frac{1}{r \sin \theta} \frac{\partial T_{\theta\phi}}{\partial \phi} + \frac{T_{\theta r}}{r} + \frac{(T_{\theta\theta} - T_{\phi\phi}) \cot \theta}{r}$
ϕ	r	$\frac{\partial T_{\phi r}}{\partial r}$	$\frac{1}{r} \frac{\partial T_{\phi r}}{\partial \theta} - \frac{T_{\phi\theta}}{r}$	$\frac{1}{r \sin \theta} \frac{\partial T_{\phi r}}{\partial \phi} + \frac{T_{rr} - T_{\phi\phi}}{r} + \frac{T_{r\theta} \cot \theta}{r}$
	θ	$\frac{\partial T_{\phi\theta}}{\partial r}$	$\frac{1}{r} \frac{\partial T_{\phi\theta}}{\partial \theta} + \frac{T_{r\phi}}{r}$	$\frac{1}{r \sin \theta} \frac{\partial T_{\phi\theta}}{\partial \phi} + \frac{T_{r\theta}}{r} + \frac{(T_{\theta\theta} - T_{\phi\phi}) \cot \theta}{r}$
	ϕ	$\frac{\partial T_{\phi\phi}}{\partial r}$	$\frac{1}{r} \frac{\partial T_{\phi\phi}}{\partial \theta}$	$\frac{1}{r \sin \theta} \frac{\partial T_{\phi\phi}}{\partial \phi} + \frac{(T_{r\phi} + T_{\phi r})}{r} + \frac{(T_{\theta\phi} + T_{\phi\theta}) \cot \theta}{r}$

From Table A8.2, we can also obtain the divergence of a second-order \mathbf{T} as:

$$\begin{aligned} (\operatorname{div} \mathbf{T})_r &= (\nabla \mathbf{T})_{rrr} + (\nabla \mathbf{T})_{r\theta\theta} + (\nabla \mathbf{T})_{r\phi\phi} \\ &= \frac{\partial T_{rr}}{\partial r} + \frac{1}{r} \frac{\partial T_{r\theta}}{\partial \theta} + \frac{2T_{rr}}{r} + \frac{1}{r \sin \theta} \frac{\partial T_{r\phi}}{\partial \phi} - \frac{T_{\theta\theta} + T_{\phi\phi}}{r} + \frac{T_{r\theta} \cot \theta}{r}, \end{aligned} \quad (8A.30)$$

$$\begin{aligned} (\operatorname{div} \mathbf{T})_\theta &= (\nabla \mathbf{T})_{\theta rr} + (\nabla \mathbf{T})_{\theta\theta\theta} + (\nabla \mathbf{T})_{\theta\phi\phi} \\ &= \frac{\partial T_{\theta r}}{\partial r} + \frac{1}{r} \frac{\partial T_{\theta\theta}}{\partial \theta} + \frac{T_{r\theta}}{r} + \frac{2T_{\theta r}}{r} + \frac{1}{r \sin \theta} \frac{\partial T_{\theta\phi}}{\partial \phi} + \frac{(T_{\theta\theta} - T_{\phi\phi}) \cot \theta}{r}, \end{aligned} \quad (8A.31)$$

$$\begin{aligned} (\operatorname{div} \mathbf{T})_\phi &= (\nabla \mathbf{T})_{\phi rr} + (\nabla \mathbf{T})_{\phi\theta\theta} + (\nabla \mathbf{T})_{\phi\phi\phi} \\ &= \frac{\partial T_{\phi r}}{\partial r} + \frac{1}{r} \frac{\partial T_{\phi\theta}}{\partial \theta} + \frac{2T_{\phi r}}{r} + \frac{1}{r \sin \theta} \frac{\partial T_{\phi\phi}}{\partial \phi} + \frac{T_{r\phi}}{r} + \frac{(T_{\theta\phi} + T_{\phi\theta}) \cot \theta}{r}. \end{aligned} \quad (8A.32)$$

We note again that these equations for $\operatorname{div} \mathbf{T}$ are the same as those obtained in Chapter 2 by using a different method.

PROBLEMS FOR CHAPTER 8

8.1 Show that for an incompressible Newtonian fluid in Couette flow, the pressure at the outer cylinder ($r = R_o$) is always larger than that at the inner cylinder. That is, obtain

$$[-T_{rr}(R_o)] - [-T_{rr}(R_i)] = \rho \int_{R_i}^{R_o} r\omega^2(r)dr.$$

8.2 Show that the constitutive equation

$$\boldsymbol{\tau} = \boldsymbol{\tau}_1 + \boldsymbol{\tau}_2 + \boldsymbol{\tau}_3, \quad \text{with} \quad \boldsymbol{\tau}_n + \lambda_n \frac{\partial \boldsymbol{\tau}_n}{\partial t} = 2\mu_n \mathbf{D}, \quad n = 1, 2, 3$$

is equivalent to

$$\boldsymbol{\tau} + a_1 \frac{\partial \boldsymbol{\tau}}{\partial t} + a_2 \frac{\partial^2 \boldsymbol{\tau}}{\partial t^2} + a_3 \frac{\partial^3 \boldsymbol{\tau}}{\partial t^3} = b_0 \mathbf{D} + b_1 \frac{\partial \mathbf{D}}{\partial t} + b_2 \frac{\partial^2 \mathbf{D}}{\partial t^2},$$

where

$$\begin{aligned} a_1 &= (\lambda_1 + \lambda_2 + \lambda_3), a_2 = (\lambda_1\lambda_2 + \lambda_2\lambda_3 + \lambda_3\lambda_1), a_3 = \lambda_1\lambda_2\lambda_3, \\ b_0 &= 2(\mu_1 + \mu_2 + \mu_3), b_1 = 2[\mu_1(\lambda_2 + \lambda_3) + \mu_2(\lambda_1 + \lambda_3) + \mu_3(\lambda_2 + \lambda_1)], \\ b_2 &= 2(\mu_1\lambda_2\lambda_3 + \mu_2\lambda_1\lambda_3 + \mu_3\lambda_1\lambda_2). \end{aligned}$$

8.3 Obtain the force-displacement relationship for the Kelvin-Voigt solid, which consists of a dashpot (with damping coefficient η) and a spring (with spring constant G) connected in parallel. Also obtain its relaxation function.

8.4 (a) Obtain the force-displacement relationship for a dashpot (damping coefficient η_o) and a Kelvin-Voigt solid (damping coefficient η and spring constant G ; see the previous problem) connected in series. (b) Obtain its relaxation function.

8.5 A linear Maxwell fluid, defined by Eq. (8.1.2), is between two parallel plates that are one unit apart. Starting from rest, at time $t = 0$, the top plate is given a displacement $u = v_o t$ while the bottom plate remains fixed. Neglect inertia effects, obtain the shear stress history.

8.6 Obtain Eq. (8.3.1), i.e., $\mathbf{S} = 2 \int_{-\infty}^t \phi(t-t') \mathbf{D}(t') dt'$, where $\phi(t) = (\mu/\lambda) e^{-t/\lambda}$, by solving the linear non-homogeneous ordinary differential equation $\mathbf{S} + \lambda d\mathbf{S}/dt = 2\mu \mathbf{D}$.

8.7 Show that $\int_{-\infty}^t \phi(t-t') J(t') dt' = t$ for the linear Maxwell fluid, defined by Eq. (8.1.2), where $\phi(t)$ is the relaxation function and $J(t)$ is the creep compliance function.

8.8 Obtain the storage modulus and loss modulus for the linear Maxwell fluid with a continuous relaxation spectrum defined by Eq. (8.4.1), i.e., $\phi(t) = \int_0^{\infty} [H(\lambda)/\lambda] e^{-t/\lambda} d\lambda$.

8.9 Show that for a linear Maxwell fluid, define by $\mathbf{S} = 2 \int_{-\infty}^t \phi(t-t') \mathbf{D}(t') dt'$, its viscosity μ is related to the relaxation function $\phi(t)$ and the memory function $f(s)$ by the relation

$$\mu = \int_0^{\infty} \phi(s) ds = - \int_0^{\infty} s f(s) ds.$$

8.10 Show that the relaxation function for the Jeffrey model [Eq. (8.2.7)] with $a_2 = 0$ is given by

$$\phi(t) = \frac{S_{12}}{\gamma_o} = \frac{b_o}{2a_1} \left[\left(1 - \frac{b_1}{b_o a_1} \right) e^{-t/a_1} + \frac{b_1}{b_o} \delta(t) \right], \quad \delta(t) = \text{Dirac Function.}$$

- 8.11** Given the following velocity field: $v_1 = 0$, $v_2 = v(x_1)$, $v_3 = 0$. Obtain (a) the particle pathline equations using the current time as the reference time, (b) the relative right Cauchy-Green deformation tensor, (c) the Rivlin-Ericksen tensors using the equation $\mathbf{C}_t = \mathbf{I} + (\tau-t)\mathbf{A}_1 + (\tau-t)^2 \mathbf{A}_2/2 + \dots$, and (d) the Rivlin-Ericksen tensor \mathbf{A}_2 using the recursive equation $[\mathbf{A}_2] = [D\mathbf{A}_1/Dt] + [\mathbf{A}_1] [\nabla\mathbf{v}] + [\nabla\mathbf{v}]^T [\mathbf{A}_1]$, etc.
- 8.12** Given the following velocity field: $v_1 = -kx_1$, $v_2 = kx_2$, $v_3 = 0$. Obtain (a) the particle pathline equations using the current time as the reference time, (b) the relative right Cauchy-Green deformation tensor, (c) the Rivlin-Ericksen tensors using the equation $\mathbf{C}_t = \mathbf{I} + (\tau-t)\mathbf{A}_1 + (\tau-t)^2 \mathbf{A}_2/2 + \dots$, and (d) the Rivlin-Ericksen tensor \mathbf{A}_2 and \mathbf{A}_3 using the recursive equation $[\mathbf{A}_2] = [D\mathbf{A}_1/Dt] + [\mathbf{A}_1] [\nabla\mathbf{v}] + [\nabla\mathbf{v}]^T [\mathbf{A}_1]$, etc.
- 8.13** Given the following velocity field: $v_1 = kx_1$, $v_2 = kx_2$, $v_3 = -2kx_3$. Obtain (a) the particle pathline equations using the current time as the reference time, (b) the relative right Cauchy-Green deformation tensor, (c) the Rivlin-Ericksen tensors using the equation $\mathbf{C}_t = \mathbf{I} + (\tau-t)\mathbf{A}_1 + (\tau-t)^2 \mathbf{A}_2/2 + \dots$, and (d) the Rivlin-Ericksen tensor \mathbf{A}_2 and \mathbf{A}_3 using the recursive equation $[\mathbf{A}_2] = [D\mathbf{A}_1/Dt] + [\mathbf{A}_1] [\nabla\mathbf{v}] + [\nabla\mathbf{v}]^T [\mathbf{A}_1]$, etc.
- 8.14** Given the following velocity field: $v_1 = kx_2$, $v_2 = kx_1$, $v_3 = 0$. Obtain (a) the particle pathline equations using the current time as the reference time, (b) the relative right Cauchy-Green deformation tensor, (c) the Rivlin-Ericksen tensors using the equation $\mathbf{C}_t = \mathbf{I} + (\tau-t)\mathbf{A}_1 + (\tau-t)^2 \mathbf{A}_2/2 + \dots$, and (d) the Rivlin-Ericksen tensor \mathbf{A}_2 and \mathbf{A}_3 using the recursive equation $[\mathbf{A}_2] = [D\mathbf{A}_1/Dt] + [\mathbf{A}_1] [\nabla\mathbf{v}] + [\nabla\mathbf{v}]^T [\mathbf{A}_1]$, etc.
- 8.15** Given the velocity field in cylindrical coordinates: $v_r = 0$, $v_\theta = 0$, $v_z = v(r)$, obtain the second Rivlin-Ericksen tensors \mathbf{A}_N , $N = 2, 3, \dots$ using the recursive formula.
- 8.16** Using the equations given in Appendix 8.1 for cylindrical coordinates, verify that the $r\theta\theta$ component of the third-order tensor $\nabla\mathbf{T}$ is given by

$$(\nabla\mathbf{T})_{r\theta\theta} = \frac{1}{r} \frac{\partial T_{rr}}{\partial \theta} - \frac{T_{\theta r} + T_{r\theta}}{r}.$$

- 8.17** Using the equations given in Appendix 8.1 for cylindrical coordinates, verify that the $r\theta\theta$ component of the third-order tensor $\nabla\mathbf{T}$ is given by

$$(\nabla\mathbf{T})_{r\theta\theta} = \frac{1}{r} \frac{\partial T_{r\theta}}{\partial \theta} + \frac{T_{rr} - T_{\theta\theta}}{r}.$$

- 8.18** Using the equations given in Appendix 8.1 for spherical coordinates, verify that the $r\theta\phi$ component of the third-order tensor $\nabla\mathbf{T}$ is given by

$$(\nabla\mathbf{T})_{r\theta\phi} = \frac{1}{r \sin \theta} \frac{\partial T_{rr}}{\partial \phi} - \frac{(T_{\phi r} + T_{r\phi})}{r}.$$

- 8.19** Using the equations given in Appendix 8.1 for spherical coordinates, verify that the $\phi\phi\phi$ component of the third-order tensor $\nabla\mathbf{T}$ is given by

$$\frac{1}{r \sin \theta} \frac{\partial T_{\phi\phi}}{\partial \phi} + \frac{T_{r\phi} + T_{\phi r}}{r} + \frac{(T_{\theta\phi} + T_{\phi\theta}) \cot \theta}{r}.$$

- 8.20** Given the velocity field in cylindrical coordinates: $v_r = 0$, $v_\theta = v(r)$, $v_z = 0$, obtain (a) first Rivlin-Ericksen tensors \mathbf{A}_1 , (b) $\nabla\mathbf{A}_1$, and (c) second Rivlin-Ericksen tensors \mathbf{A}_2 using the recursive formula.

8.21 Derive Eq. (8.11.3), i.e., $\mathbf{A}_{N+1} = \frac{D\mathbf{A}_N}{Dt} + \mathbf{A}_N(\nabla\mathbf{v}) + (\nabla\mathbf{v})^T\mathbf{A}_N$.

8.22 Let $\mathbf{S} \equiv \frac{D\mathbf{T}}{Dt} + \mathbf{T}\mathbf{W} - \mathbf{W}\mathbf{T}$, where \mathbf{T} is an objective tensor and \mathbf{W} is the spin tensor. Show that \mathbf{S} is objective, i.e., $\mathbf{S}^* = \mathbf{Q}(t)\mathbf{S}\mathbf{Q}^T(t)$.

8.23 Obtain the viscosity function and the two normal stress functions for the nonlinear viscoelastic fluid defined by $\mathbf{S} = \int_0^\infty f_2(s) [\mathbf{I} - \mathbf{C}_t^{-1}(t-s)] ds$.

8.24 Derive the following transformation laws [Eqs. (8.13.8) and (8.13.12)] under a change of frame.

$$\mathbf{v}_t^* = \mathbf{Q}(\tau)\mathbf{v}_t\mathbf{Q}^T(\tau) \quad \text{and} \quad \mathbf{R}_t^* = \mathbf{Q}(\tau)\mathbf{R}_t\mathbf{Q}^T(\tau).$$

8.25 From $\check{\mathbf{T}} \equiv \left[\frac{D\mathbf{J}_L(\tau)}{D\tau} \right]_{\tau=t}$ and $\left[\frac{D\mathbf{F}_t(\tau)}{D\tau} \right]_{\tau=t} = \nabla\mathbf{v}$, show that $\check{\mathbf{T}} = \overset{\circ}{\mathbf{T}} + \mathbf{T}\mathbf{D} + \mathbf{D}\mathbf{T}$.

8.26 Consider $\mathbf{J}_U(\tau) = \mathbf{F}_t^{-1}(\tau)\mathbf{T}(\tau)\mathbf{F}_t^{-1T}(\tau)$. Show that (a) $\left[\frac{D\mathbf{J}_U(\tau)}{D\tau} \right]_{\tau=t}$ is objective and (b) $\left[\frac{D\mathbf{J}_U(\tau)}{D\tau} \right]_{\tau=t} = \frac{D\mathbf{T}}{D\tau} - \mathbf{T}(\nabla\mathbf{v})^T - (\nabla\mathbf{v})\mathbf{T} = \overset{\circ}{\mathbf{T}} - (\mathbf{T}\mathbf{D} + \mathbf{D}\mathbf{T})$.

8.27 Given the velocity field of a plane Couette flow: $v_1 = 0$, $v_2 = kx_1$. (a) For a Newtonian fluid, find the stress field $[\mathbf{T}]$ and the corotational stress rate $[\overset{\circ}{\mathbf{T}}]$. (b) Consider a change of frame (change of observer) described by

$$\begin{bmatrix} x_1^* \\ x_2^* \end{bmatrix} = \begin{bmatrix} \cos \omega t & -\sin \omega t \\ \sin \omega t & \cos \omega t \end{bmatrix} \begin{bmatrix} x_1 \\ x_2 \end{bmatrix}, \quad [\mathbf{Q}] = \begin{bmatrix} \cos \omega t & -\sin \omega t \\ \sin \omega t & \cos \omega t \end{bmatrix}.$$

Find $[\mathbf{v}^*]$, $[\nabla^*\mathbf{v}^*]$, $[\mathbf{D}^*]$ and $[\mathbf{W}^*]$. (c) Find the corotational stress rate for the starred frame. (d) Verify that the two stress rates are related by the objective tensorial relation.

8.28 Given the velocity field: $v_1 = -kx_1$, $v_2 = kx_2$, $v_3 = 0$. Obtain (a) the stress field for a second-order fluid and (b) the corotational derivative of the stress tensor.

8.29 Show that the lower convected derivative of \mathbf{A}_1 is \mathbf{A}_2 , i.e., $\check{\mathbf{A}}_1 = \mathbf{A}_2$.

8.30 The Reiner-Rivlin fluid is defined by the constitutive equation

$$\mathbf{T} = -p\mathbf{I} + \mathbf{S}, \quad \mathbf{S} = \phi_1(I_2, I_3)\mathbf{D} + \phi_2(I_2, I_3)\mathbf{D}^2,$$

where I_i are the scalar invariants of \mathbf{D} . Obtain the stress components for this fluid in a simple shearing flow.

8.31 The exponential of a tensor \mathbf{A} is defined as $\exp[\mathbf{A}] = \mathbf{I} + \sum_1^N \frac{1}{n!} \mathbf{A}^n$. If \mathbf{A} is an objective tensor, is $\exp[\mathbf{A}]$ also objective?

8.32 Why is the following constitutive equation not acceptable? $\mathbf{T} = -p\mathbf{I} + \mathbf{S}$, $\mathbf{S} = \alpha(\nabla\mathbf{v})$, where \mathbf{v} is velocity and α is a constant.

8.33 Let da and $d\mathbf{A}$ denote the differential area vectors at time τ and time t , respectively. For an incompressible fluid, show that

$$\left[\frac{D^N da^2}{D\tau^N} \right]_{\tau=t} = d\mathbf{A} \cdot \left[\frac{D^N \mathbf{C}_t^{-1}}{D\tau^N} \right]_{\tau=t} d\mathbf{A} \equiv -d\mathbf{A} \cdot \mathbf{M}_N d\mathbf{A},$$

where da is the magnitude of da and the tensors \mathbf{M}_N are known as the *White-Metzner tensors*.

8.34 (a) Verify that the Oldroyd lower convected derivatives of the identity tensor \mathbf{I} are the Rivlin-Ericksen tensors \mathbf{A}_N . (b) Verify that the Oldroyd upper derivatives of the identity tensor are the negative White-Metzner tensors (see Prob. 8.33 for the definition of *White-Metzner tensor*).

8.35 Obtain $\overset{\circ}{\mathbf{T}} = \frac{D\mathbf{T}}{Dt} + \mathbf{T}\nabla\mathbf{v} + (\nabla\mathbf{v})^T\mathbf{T}$, where $\overset{\circ}{\mathbf{T}}$ is the lower convected derivative of \mathbf{T} .

8.36 Consider the following constitutive equation: $\mathbf{S} + \lambda \frac{D_*\mathbf{S}}{Dt} = 2\mu\mathbf{D}$, where $\frac{D_*\mathbf{S}}{Dt} \equiv \overset{\circ}{\mathbf{S}} + \alpha(\mathbf{D}\mathbf{S} + \mathbf{S}\mathbf{D})$ and $\overset{\circ}{\mathbf{S}}$ is corotational derivative of \mathbf{S} . Obtain the shear stress function and the two normal stress functions for this fluid.

8.37 Obtain the apparent viscosity and the normal stress functions for the Oldroyd 3-constant fluid [see Part (C) of Section 8.20].

8.38 Obtain the apparent viscosity and the normal stress functions for the Oldroyd 4-constant fluid [see Part (D) of Section 8.20].

8.39 Given $[\mathbf{Q}] = \begin{bmatrix} -1 & 0 & 0 \\ 0 & 1 & 0 \\ 0 & 0 & 1 \end{bmatrix}_{\{\mathbf{n}_i\}}$, $[\mathbf{N}] = \begin{bmatrix} 0 & 1 & 0 \\ 0 & 0 & 0 \\ 0 & 0 & 0 \end{bmatrix}_{\{\mathbf{n}_i\}}$, $\mathbf{A}_1 = k(\mathbf{N} + \mathbf{N}^T)$ and $\mathbf{A}_2 = 2k^2\mathbf{N}^T\mathbf{N}$. (a) Verify

that $\mathbf{Q}\mathbf{A}_1\mathbf{Q}^T = -\mathbf{A}_1$ and $\mathbf{Q}\mathbf{A}_2\mathbf{Q}^T = \mathbf{A}_2$. (b) From $\mathbf{T} = -p\mathbf{I} + \mathbf{f}(\mathbf{A}_1, \mathbf{A}_2)$ and $\mathbf{Q}\mathbf{f}(\mathbf{A}_1, \mathbf{A}_2)\mathbf{Q}^T = \mathbf{f}(\mathbf{Q}\mathbf{A}_1\mathbf{Q}^T, \mathbf{Q}\mathbf{A}_2\mathbf{Q}^T)$, show that $\mathbf{Q}\mathbf{T}(k)\mathbf{Q}^T = \mathbf{T}(-k)$.

(c) From the results of part (b), show that the viscometric functions have the properties:

$$S(k) = -S(-k), \quad \sigma_1(k) = \sigma_1(-k), \quad \sigma_2(k) = \sigma_2(-k).$$

8.40 For the velocity field given in Example 8.21.2, i.e., $v_r = 0$, $v_\theta = 0$, $v_z = v(r)$, (a) obtain the stress components in terms of the shear stress function $S(k)$ and the normal stress functions $\sigma_1(k)$ and $\sigma_2(k)$, where $k = dv/dr$; (b) obtain the velocity distribution $v(r) = \int_r^R \gamma(fr/2)dr$ for the Poiseuille flow under a pressure gradient of $-f$, where γ is the inverse shear stress function; and (c) obtain the relation

$$\gamma\left(\frac{Rf}{2}\right) = \frac{1}{\pi R^3 f^2} \frac{\partial(f^3 Q)}{\partial f}.$$

This page intentionally left blank

References

Indicial Notation, Vectors, and Tensors

- [1] Aris R. Vectors, Tensors, and the Basic Equations of Fluid Mechanics. Englewood Cliffs, New Jersey: Prentice Hall, Inc.; 1962 (also, Dover Books in Engineering).
- [2] Coleman BD, Markowitz H, Noll W. Appendix. In: Viscometric Flows of Non-Newtonian Fluids. New York: Springer-Verlag; 1966.
- [3] Goodbody AM. Cartesian Tensors: With Applications to Mechanics, Fluid Mechanics, and Elasticity. New York: Halsted Press; 1982.
- [4] Jeffreys H. Cartesian Tensors. Cambridge University Press; 1961.
- [5] Kaplan W. Advance Calculus. Addison-Wesley; 1991.
- [6] Venit SM. Elementary Linear Algebra. Brooks-Cole; 1995.
- [7] Sokolnikoff IS. Tensor Analysis: Theory and Applications. New York: John Wiley & Sons, Inc.; 1951, 1963.

Kinematics, Deformations, and Stresses

- [8] Bird RB, Armstrong RC, Hassger O. Dynamics of Polymeric Liquids, Vol. 1: Fluid Mechanics. New York: Wiley & Sons; 1987.
- [9] Eringen AC. Mechanics of Continua. New York: Wiley; 1967.
- [10] Fung YC. First Course in Continuum Mechanics, 3rd ed. Englewood Cliffs, New Jersey: Prentice Hall; 1977, 1994.
- [11] Fung YC. Foundation of Solid Mechanics. Englewood Cliffs: Prentice Hall; 1965.
- [12] Leigh DC. Nonlinear Continuum Mechanics. New York: McGraw-Hill; 1978.
- [13] Malvern E. Introduction to the Mechanics of a Continuous Medium. Englewood Cliffs, New Jersey: Prentice Hall; 1969, 1977.
- [14] Truesdell C. The Elements of Continuum Mechanics. New York: Springer-Verlag; 1966; New Jersey: Secaucus; 1985.
Also Refs. 1, 2.

Theory of Elasticity

- [15] L'ure AI. Theory of Elasticity. Berlin: Springer; 2005.
- [16] Barber JR. Elasticity. Kluwer Academic Publisher; 2002.
- [17] Gould P. Introduction to Linear Elasticity. Springer-Verlag; 1994.
- [18] Green AE, Zerna W. Theoretical Elasticity. New Jersey: Oxford University Press; 1954 (also, Dover Phoenix Editions).
- [19] Timoshenko SP, Goodier JN. Theory of Elasticity, 3rd ed., New York: McGraw-Hill; 1970, 1987.
- [20] Sokolnikoff IS. Mathematical Theory of Elasticity, 2nd ed., New York: McGraw-Hill; 1956.
Also Refs. 9, 10, 11, 13, 14.

Newtonian Fluid Mechanics

- [21] Schlichting H. Boundary Layer Theory, 7th ed., New York, McGraw-Hill; 1979.
- [22] Yih CS. Fluid Mechanics: A Concise Introduction to the Theory. McGraw-Hill, 1969, West River Press, 1988.
Also Refs. 1, 3.

Non-Newtonian Fluid Mechanics

- [23] Astarita G, Marrucci G. Principles of Non-Newtonian Fluid Mechanics. Maiden Head, England: McGraw-Hill (UK); 1974.
- [24] Ferry JD. Viscoelastic Properties of Polymers, 2nd ed., New York: Wiley; 1970, 3rd ed., 1980.
- [25] Coleman BD, Markowitz H, Noll W. Appendix. In: Viscometric Flows of Non-Newtonian Fluids. New York: Springer-Verlag; 1966.
- [26] Showalter WR. Mechanics of Non-Newtonian Fluids. Pergamon Press; 1978.

Also: Refs. 8, 14.

Advanced Continuum Mechanics

- [27] Truesdell C, Noll W. The Non-Linear Theories of Mechanics. New York: Springer-Verlag; 1992, 2004.
- [28] Truesdell C, Toupin R. The Classical Field Theory. In: Flugge S, editor. Encyclopedia of Physics, vol. III, Pt. 1. Berlin: Springer-Verlag; 1960.

Index

Note: Page numbers followed by *f* indicates figures and *t* indicates tables.

A

- Acceleration of particle
 - in cylindrical coordinates, 77
 - in rectangular Cartesian coordinates, 76
 - in spherical coordinates, 78
- Acoustic wave, Newtonian fluids
 - barotropic, 393
 - fluid impedance, 396
 - local speed of sound, 394
- Adherence condition, 365
- Airy stress function, 251, 270–274
- Anisotropic linearly elastic solid
 - constitutive equation
 - anisotropic linearly elastic solid, 319–321
 - isotropic linearly elastic solid, 207–209
 - monoclinic linearly elastic solid, 322–324
 - orthotropic linearly elastic solid, 324–325
 - transversely isotropic linearly elastic material, 325–327
 - engineering constants
 - isotropic linearly elastic solid, 328
 - monoclinic linearly elastic solid, 332–333
 - orthotropic linearly elastic solid, 330–331
 - transversely isotropic linearly elastic solid, 329–330
 - material symmetry plane, 321–322
- Antisymmetric tensors
 - definition of, 32
 - dual vector of, 32–34

B

- Bernoulli's equations, 383
- BKZ model, 480
- Boundary layer concepts, 388–389
- Bulk modulus, 203, 211
- Bulk viscosity, 359

C

- Cauchy stress tensor *see* Stress tensor
- Cauchy-Green deformation tensor, 337, 476
- Cauchy's equations of motion, 169
- Cauchy's stress principle, 156
- Compliance matrix, 320
- Compressible newtonian fluid, 389–390
- Conservation of energy, 184
 - principle of, 433–435
 - supersonic one-dimensional flow, 434

- Conservation of mass
 - linear momentum, 421–422
 - principle of, 420–422
- Constitutive equations, 2
 - anisotropic linearly elastic solid, 319–321
 - isotropic elastic solid
 - elastic medium, 338–340
 - isotropic elastic medium, 340–342
 - isotropic linearly elastic solid, 207–209
 - monoclinic linearly elastic solid, 322–324
 - orthotropic linearly elastic solid, 324–325
 - transversely isotropic linearly elastic material, 325–327
- Continuum mechanics
 - constitutive equations of, 2
 - general principles of, 1–2
- Continuum theory, 1
- Corotational derivative, 483–484
- Couette flow, 374–375
- Curvilinear coordinates
 - cylindrical coordinates, 60–61
 - polar coordinates, 55–59
 - spherical coordinates, 62–67
- Cylindrical coordinates, 504
 - and spherical coordinates, 170–171

D

- Deformation, kinematics of continuum
 - change of area, 129–130
 - change of volume, 131–132
 - gradient, 419
 - cylindrical and spherical coordinates, 88
 - definition, 105–107
 - rectangular coordinates, 87
 - stretch and rotation tensors calculation, 112–114
 - tensor deformation components
 - cylindrical coordinates, 132–138
 - spherical coordinates, 139–140
- Dilatational waves, 219
- Displacement field, 81–82
- Dissipation functions, Newtonian fluids
 - compressible, 377
 - incompressible, 376–377
 - stress working, or stress power, 376
- Divergence of tensor field, 51–52

Divergence theorem

- Cartesian components, 414–415
- stress vector, 415
- total power, 416

Dummy index, 3

E

Einstein's summation convention, 3

Elastic solid materials

- homogenous and inhomogenous properties, 203
- mechanical properties
 - bulk modulus, 203
 - load-elongation diagram, 202, 202f
 - shear modulus, 203
 - tensile test, 203
 - Young's modulus, 202

Elasticity tensor, 204

Elastostatic problems

- Boussinesq problem, 293–295
- elastic half-space surface
 - axisymmetric smooth indenter, 302–304, 306–309
 - distributive normal load, 296–297
 - flat-ended indenter, 304
 - rigid flat-ended smooth indenter, 300–301
 - smooth rigid sphere, 304–306
- hollow sphere, 297–298
- Kelvin problem, 290–291
- potential functions, 279–289
- spherical hole in tensile field, 298–300

Engineering constants

- isotropic linearly elastic solid, 328
- monoclinic linearly elastic solid, 332–333
- orthotropic linearly elastic solid, 330–331
- transversely isotropic linearly elastic solid, 329–330

Entropy inequality, 435

- Helmholtz energy function, 186–187
- law, 185

Eulerian description, 72

Eulerian strain tensor, 125–129

Euler's equations, 382

F

Finger deformation tensor, 122–125

First coefficient viscosity, 359

First Piola Kirchhoff, 175

First Piola-Kirchhoff and Cauchy stress tensor relations, 175

G

Generalized shear modulus, 344

Green's deformation tensor, 114–118

Green's theorem

- area integral, 413
- boundary curve of, 411–413

H

Hagen-Poiseuille flow, 371–372

Helmholtz energy function, entropy inequality, 186–187

Hookean elastic solid materials *see* Linearly elastic solid materials

Hugoniot equation, 399

Hydrostatic state of stress, 211

I

Idealized materials, 2

Identity tensors

- Cartesian components of, 21
- definition of, 20

Incompressible fluids

- Navier-Stokes equations
 - cylindrical coordinates, 364
 - parallel flow or unidirectional flow, 361
 - piezometric head, 362–363
 - spherical coordinates, 364–365
- plane Couette flow, 372–374
- vorticity transport equation, 385–388

Incompressible hyperelastic isotropic solid, 342

Incompressible Newtonian fluid, 359–360

Incompressible simple fluid, viscometric flow

- channel flow
 - Newtonian fluid, 497
 - volume flux per unit width, 496

Couette flow

- compressive stress, 499–500
- material function, 500
- velocity and stress distribution, 498
- gradient of second-order tensor, 501–505
- stresses, 493–495

Indeterminate pressure, 359

Indicial notation, in tensors

- Einstein's summation convention and dummy indices, 3
- free indices, 4
- Kronecker delta, 5
- manipulations, 7
- permutation symbol, 6

Infinitesimal deformation

- deformation gradient, 85
- displacement gradient, 84–85
- Lagrange strain tensor, 87
- right Cauchy-Green deformation tensor, 85–87

Infinitesimal rotation tensor, 94–95

Infinitesimal strain tensor

- diagonal elements, 88
- off diagonal elements, 89

Interpretation of λ and μ , Newtonian fluid

- first coefficient viscosity, 359
- second coefficient viscosity, 359
- stokes assumption, 359

- Inviscid incompressible fluid
 - barotropic flow, 395
 - isentropic irrotational flows, 397
 - Mach number, 398
 - Irrotational flow
 - inviscid incompressible fluid
 - Bernoulli's equations, 383
 - Euler's equation of motion, 382
 - Torricelli's formula, 384
 - Navier-Stokes equation solutions, 384–385
 - Isotropic elastic solid, large deformation
 - bending of, rectangular bar, 344–347
 - change of frames
 - objective scalar, 334
 - objective tensor, 335
 - objective vector, 334
 - constitutive equation
 - elastic medium, 338–340
 - isotropic elastic medium, 340–342
 - simple extension, 342
 - simple shear deformation, 343
 - torsion and tension, 347–349
 - Isotropic linearly elastic solid materials
 - constitutive equations for, 208
 - elastostatic problems
 - Boussinesq problem, 293–295
 - hollow sphere, 297–298
 - Kelvin problem, 289–292
 - potential functions, 279–289
 - spherical hole in tensile field, 298–300
 - elastostatic problems, elastic half-space surface
 - axisymmetric smooth indenter, 302–304, 306–309
 - distributive normal load, 296–297
 - rigid flat-ended smooth indenter, 300–301
 - smooth rigid sphere, 304–306
 - infinitesimal theory of elasticity, 213–215
 - isotropic tensor, 207–208
 - Navier's equations
 - cylindrical coordinates, 216–217
 - of motion for elastic medium, 215–216
 - spherical coordinates, 217–218
 - plane elastic waves
 - infinite plate vibration, 229–231
 - plane equivoluminal waves, 221–225
 - plane irrotational waves, 218–221
 - reflection of, 225–228
 - plane stress and strain solutions
 - Airy stress function, 251
 - cantilever beam with end load, 255–258
 - curved beam bending, 268–269
 - Flamont problem, 278–279
 - rectangular beam bent by end couples, 253–254
 - simple radial distribution, 277–278
 - simply supported beam, 258–259
 - slender bar, 260–262
 - strain conversion, 262–263
 - strain solutions, 250–253
 - stress concentration due to small circular hole in plate, 274–275, 276–277
 - stress problem, 254–255
 - symmetrical stress distribution, 265–267
 - thick-walled circular cylinder, 267–268
 - two dimensional problems, 264
 - simple bending of beam, 247–250
 - definition, 247
 - flexural stress, 249
 - simple extension
 - St. Venant's principle, 234
 - three-dimensional elastostatic problems, 231–234
 - stress components
 - bulk modulus, 211
 - hydrostatic state of stress, 211
 - Lamé's constants, 208
 - modulus of elasticity, 210
 - Poisson's ratio, 210
 - shear modulus, 211
 - simple shear stress state, 211
 - uniaxial stress state, 210
 - superposition principle, 218
 - torsion
 - of circular cylinder, 234–239
 - of elliptical bar, 240–242
 - of noncircular cylinder, 239
 - Prandtl's formulation, 242–245
 - of rectangular bar, 245–247
 - Isotropic tensor-valued function, 349–351
- J**
- Jaumann derivative, 483–484
- K**
- Kinematics of continuum
 - acceleration of particle
 - in cylindrical coordinates, 77
 - in rectangular Cartesian coordinates, 76
 - in spherical coordinates, 78
 - compatibility conditions
 - infinitesimal strain components, 101–105
 - rate of deformation components, 105
 - conservation of mass equation, 99–101
 - current configuration as reference configuration, 140–141
 - deformation
 - change of area, 129–130
 - change of volume, 131–132
 - deformation gradient
 - cylindrical and spherical coordinates, 88
 - definition, 105–107
 - rectangular coordinates, 87
 - stretch and rotation tensors calculation, 112–114

Kinematics of continuum (*Continued*)

- dilatation, 94
 - displacement field, 81–82
 - Eulerian strain tensor, 125–129
 - finite deformation, 107–109
 - infinitesimal deformation
 - deformation gradient, 85
 - displacement gradient, 84–85
 - Lagrange strain tensor, 87
 - right Cauchy-Green deformation tensor, 85–87
 - infinitesimal rotation tensor, 94–95
 - infinitesimal strain tensor
 - diagonal elements, 88
 - off diagonal elements, 89
 - kinematic equation for rigid body motion, 82–83
 - Lagrangian strain tensor, 119–122
 - left Cauchy-Green deformation tensor, 122–125
 - local rigid body motion, 107
 - material and spatial descriptions, 72–74
 - material derivative, 74–76
 - motions of continuum
 - description of, 69–72
 - material coordinates, 70
 - simple shearing motion, 70–72
 - polar decomposition theorem, 110–112
 - positive definite root, 143–145
 - positive definite symmetric tensors, 144
 - principal strain, 93
 - rate of deformation tensor, 96–99
 - right Cauchy-Green deformation tensor, 114–118
 - spin tensor and angular velocity vector, 99
 - strain compatibility, 141–143
 - tensor deformation components
 - cylindrical coordinates, 132–138
 - spherical coordinates
 - time rate of change of material element, 95–96
- Kronecker delta, definition, 5

L

- Lagrangian description, 72
- Lagrangian strain tensor, 119–122
- Lagrangian stress tensor, 175
- Lamé's constants, 208
- Linear Maxwell fluid, non-Newtonian fluids
 - with continuous relaxation spectrum, 452–454
 - creep experiment, 444
 - with discrete relaxation spectra, 451–452
 - Maxwell element, 444
 - phase angle, 450
 - with relaxation spectra, 455–456
 - relaxation spectrum and relaxation function, 454–455
 - shear stress, 448–450
 - storage and loss modulus, 454
 - stress field, 445

- stress relaxation experiment, 444
- synovial fluid, 455

Linear momentum

- boundary layer flow, 427
 - force per unit width, 427
 - homogeneous rope, 424–426
 - Piola-Kirchhoff stress tensor, 423
 - principle of, 168–170, 422–427
 - total resultant force, 425–426
 - volume flow rate, 425
- Linear viscoelastic fluid, 444
- Linearly elastic solid materials, 204
- Elasticity tensor, 204
 - strain energy function, 205
- Linearly viscous fluid *see* Newtonian fluids

M

- Material coordinates, 70
 - Maximum shearing stresses
 - determination cases
 - $T_1=T_2 \neq T_3$, 192
 - $T_1=T_2=T_3=T$, 191
 - $T_2=T_3 \neq T_1$, 192
 - $T_3=T_1 \neq T_2$, 193
 - T_i s are distinct, 193
 - Lagrange multiplier, 164
 - state of plane stress, 166
- Maxwell element, 444
- Mechanics, general principles
 - conservation of energy, 190
 - conservation of mass, 187–188
 - divergence theorem, 188
 - entropy inequality, 186–187
 - linear momentum, 188
 - moment of momentum, 189
- Modulus of elasticity, 202
- Monoclinic material, 322

N

- Navier-Stokes equations, incompressible fluids
 - cylindrical coordinates, 364
 - parallel flow or unidirectional flow, 361
 - piezometric head, 362–363
 - spherical coordinates, 364–365
- Newtonian fluids
 - acoustic wave
 - barotropic, 393
 - fluid impedance, 395
 - local speed of sound, 394
 - boundary conditions, 365
 - compressible and incompressible fluids, 354
 - Couette flow, 374–375
 - definition of fluid, 353
 - dissipation functions

compressible, 377
 incompressible, 376–377
 stress working/stress power, 376
 energy equation, 378–379
 energy equation enthalpy, 390–392
 Hagen-Poiseuille flow, 371–372
 hydrostatic pressure, 354
 interpretation of λ and μ
 first coefficient viscosity, 359
 second coefficient viscosity, 359
 stokes assumption, 359
 inviscid incompressible fluid
 Bernoulli's equations, 383
 Euler's equation of motion, 382
 Torricelli's formula, 384
 irrotational flow, 381–382
 laminar and turbulent flow, 367–368
 Navier-Stokes equations, 360–363
 oscillating plane, 375–376
 pathline, 366–367
 plane Couette flow, 368
 plane Poiseuille flow, 368–370
 pressure-flow relation, 401–403
 rate of deformation, 358
 shear stress, 356
 solutions of navier-stokes equation solutions, 384–385
 steady and unsteady flow, 367
 steady flow of a compressible fluid
 choked flow, 401
 convergent-divergent nozzle case, 402
 divergent (convergent) nozzle case, 400–401
 streamline, 365–366
 viscous stress tensor, 358
 vorticity vector, 379–381
Non-Newtonian fluids
 linear Maxwell fluid
 with continuous relaxation spectrum, 452–454
 creep experiment, 445
 with discrete relaxation spectra, 451–452
 Maxwell element, 444
 phase angle, 450
 with relaxation spectra, 455–456
 relaxation spectrum and relaxation function, 454–455
 storage and loss modulus, 454
 stress field, 445
 stress relaxation experiment, 444
 synovial fluid, 455
 nonlinear viscoelastic fluid
 BKZ model, 480
 Cauchy-Green deformation tensor, 476
 convected Maxwell fluid, 488–489
 corotational derivative, 483–484
 corotational Jeffrey fluid, 489–490
 current configuration, 455–457
 cylindrical coordinates, 461–462

 differential-type equations, incompressible fluids, 481–483
 incompressible simple fluid, 474–475
 single integral-type nonlinear equations, 478–480
 objective rate of stress, 483–487
 Oldroyd 3-constant fluid, 490
 Oldroyd 4-constant fluid, 490–491
 Oldroyd derivative
 lower convected, 484–485
 upper convected, 486–487
 rate-type constitutive equations, 487–491
 rectangular coordinates, 460–461
 relative deformation gradient, 457–458
 relative deformation tensors, 459–460
 Rivlin-Ericksen incompressible fluid of complexity, 481
 Nonslip condition, 365

O

Oldroyd derivative, non-Newtonian fluids
 lower convected, 484–485
 upper convected, 486–487
 Orthogonal tensors, 22–24
 Orthotropic elastic material, 324–325

P

Permutation symbol, 6
 Piola-Kirchhoff stress tensors, 338, 339, 423–424
 deformed configuration, 177
 equilibrium configuration, 177
 first law, 175
 second law, 176
 stress power, 181–183
 Plane Couette flow, 368
 Plane elastic waves
 infinite plate vibration, 229–231
 plane equivoluminal waves, 221–225
 plane irrotational waves
 definition of, 219
 elastodynamic problems, 218
 reflection of
 critical angle, 228
 experimental study, 225–227
 refraction index, 228
 Plane Poiseuille flow, 368–370
 Plane stress and strain solutions
 Airy stress function, 251, 270–274
 cantilever beam with end load, 255–258
 curved beam bending, 268–269
 Flamont problem, 278–279
 rectangular beam bent by end couples, 253–254
 simple radial distribution, 277–278
 simply supported beam, 258–259
 slender bar, 260–262
 strain conversion, 262–263
 strain solutions, 250–253

Plane stress and strain solutions (*Continued*)
 stress concentration, small circular hole in plate
 under pure shear, 276–277
 under tension, 274–275
 stress problem
 approximations and assumptions, 254–255
 consequences of, 255
 in welded ring, 270
 symmetrical stress distribution
 about an axis, 265
 in plane stress solution, 265–267
 thick-walled circular cylinder, 267–268
 two dimensional problems, 264
 Poisson's ratio, 210
 Polar decomposition theorem, 109–112
 Principal scalar invariants, 40–41
 Principal strain, 93

R

Real symmetric tensors
 matrix of, 39–40
 principal values and principal directions of, 38–39
 Recursive formula *see* Rivlin-Ericksen tensors
 Reference description, 72
 Relative deformation gradient, 457–458
 Relative deformation tensor, 460–463
 Reynolds number, 367–368
 Reynolds transport theorem
 conservation of energy
 principle of, 433–435
 supersonic one-dimensional flow, 434
 conservation of mass
 linear momentum, 421–422
 principle of, 420–422
 divergence theorem
 Cartesian components, 414–415
 stress tensor field, 415
 total power, 416
 Green's theorem, 411–413
 area integral, 413
 boundary curve of, 411–413
 integrals over control and material volumes
 density field, 417
 material volume and the rate of change, 417–418
 linear momentum
 boundary layer flow, 426
 force per unit width, 427
 homogeneous rope, 424–426
 Piola-Kirchhoff stress tensor, 423
 principle of, 422–427
 total resultant force, 425–426
 volume flow rate, 425
 moment of momentum
 principle of, 430–432

 sprinkler arms, 432
 moving frames
 control volume fixed, 430
 momentum principle, 428–430
 Rivlin-Ericksen tensors
 axisymmetric velocity field, 464–465
 BKZ model, 480
 Cauchy-Green deformation tensor, 476
 convected Maxwell fluid, 488–489
 corotational derivative, 483–484
 corotational Jeffrey fluid, 489–490
 differential-type equations, incompressible fluids, 483–484
 incompressible fluid of complexity, 481
 incompressible simple fluid, 474–475
 objective rate of stress, 483–487
 Oldroyd 3-constant fluid, 490
 Oldroyd 4-constant fluid, 490–491
 Oldroyd derivative
 lower convected, 484–485
 upper convected, 486–487
 rate-type constitutive equations, 487–491
 recursive formula, 468–470
 second-order fluid
 simple shearing flow, 482
 stress components, 482–483
 single integral-type nonlinear equations, 475–480
 Tanner and Simmons model fluid, 477
 transformation law, 471–473
 velocity gradient and deformation gradient, 471
 Rivlin's universal relation, 349

S

Scalar function, in tensors
 Laplacian of scalar field, 53
 scalar field and gradient, 47–50
 tensor-valued function, 45–47
 Second coefficient viscosity, 359
 Second law of thermodynamics *see* Entropy inequality
 Second-order fluid, 481–483
 Shear modulus, 203, 211
 Shear wave, 221
 Shearing stresses, 158
 Simple extension
 isotropic elastic solid under large deformation, 342
 isotropic linearly elastic solid materials
 St. Venant's principle, 234
 three-dimensional elastostatic problems, 231–234
 Simple shear stress state, 211
 Single integral-type nonlinear constitutive equations, 475–478
 Spatial coordinates, 72
 Spatial description, 72
 Spherical coordinates, 462–463
 Steady flow, compressible fluid
 choked flow, 402

convergent-divergent nozzle case, 402

Stiffness matrix
 definition, 319–320
 positive definite matrix, 320

Strain energy function
 definition of, 205
 in thermoelastic theory, 206

Stress and integral formulations
 Cauchy's equations of motion, 169
 Cauchy's stress principle, 156
 conservation of energy statement, 184
 cylindrical and spherical coordinates, 170–171
 determination, maximum shearing stress
 $T_1 = T_2 \neq T_3$, 192
 $T_1 = T_2 = T_3 = T$, 191
 $T_2 = T_3 \neq T_1$, 192
 $T_3 = T_1 \neq T_2$, 193
 T_i s are distinct, 193

energy equation, 184

entropy inequality
 Helmholtz energy function, 186–187
 law, 185

equations of motion, reference configuration, 179–180

maximum shearing stresses
 Lagrange multiplier, 164
 state of plane stress, 166

mechanics, general principles
 conservation of energy, 190
 conservation of mass, 187–188
 divergence theorem, 188
 entropy inequality, 190–191
 linear momentum, 188
 moment of momentum, 189

principal stresses, 161

principle of linear momentum, 168–170

rate of heat flow, 183–184

stress power, 180–181

stress tensor, 156–157

stress vector, 155–156

surface tractions, 171

Stress power, 180–181

Stress tensor
 boundary condition for, 171–174
 components of, 158–159
 hydrostatic state of stress, 160
 Piola Kirchhoff equations
 deformed configuration, 177
 equilibrium configuration, 177
 first law, 175
 second law, 176
 stress power, 181–183
 symmetry of, 159–161

Stress vector, 155–156

Symmetric tensors, 31–32, 434

Synovial fluid, 455

T

Tanner and Simmons model fluid, 477

Tensile and compressive stresses, 158

Tensor calculus
 divergence of tensor field, 51–52
 scalar function
 Laplacian of scalar field, 53
 scalar field and gradient, 47–50
 tensor-valued function, 45–47
 vector function
 curl of vector field, 52–53
 Laplacian of vector field, 53–54
 vector field and gradient, 50–51

Tensor deformation components
 cylindrical coordinates, 132–138

Tensors
 components of, 11
 curvilinear coordinates
 cylindrical coordinates, 60–61
 polar coordinates, 55–59
 spherical coordinates, 62–67
 dyadic product of vectors, 19–20
 eigenvalues and eigenvectors of, 34–38
 identity tensor
 Cartesian components of, 21
 definition of, 20
 indicial notation
 Einstein's summation convention and dummy indices, 16
 free indices, 4
 Kronecker delta, 5
 manipulations, 7
 permutation symbol, 6
 linear transformation, 9
 orthogonal tensor, 22–24
 principal scalar invariants, 40–41
 product of two tensors, 16–18
 real symmetric tensors
 matrix of, 39–40
 principal values and principal directions of, 38–39
 sum of, 16
 symmetric and antisymmetric tensors, 31–32
 trace of, 20
 transformation laws
 addition rule, 30
 multiplication rule, 30
 quotient rule, 31
 transformation matrix, 24–26
 transformed vector components, 14–16
 transpose of, 18–19

Torricelli's formula, 384

Torsion
 of circular cylinder, 234–239
 of elliptical bar, 240–242
 of incompressible isotropic solid cylinder, 347–349

Torsion (*Continued*)

- of noncircular cylinder, 239–240
- Prandtl's formulation, 242–245
- of rectangular bar, 245–247

Transformation laws

Cartesian components

- of tensor, 27–29
- of vector, 26–27

Cauchy-Green deformation tensor, 337

relative deformation tensors, 471–473

Rivlin-Ericksen tensors, 474

by tensors

- addition rule, 30
- multiplication rule, 30
- quotient rule, 31

Transversely isotropic material, 325

Two-dimensional flows case, vorticity transport equation, 385–388

U

Uniaxial stress state, 210

V

Vector function, in tensors

- curl of vector field, 52–53
- Laplacian of vector field, 53–54
- vector field and gradient, 50–51

Velocity gradient and deformation gradient, 471

Viscometric flow, incompressible simple fluid

- channel flow, 493–495
 - Newtonian fluid, 497
 - volume flux per unit width, 496

Couette flow, 497–501

material function, 500

velocity and stress distribution, 498

gradient of second-order tensor, 501–505

stresses, 493–495

Vorticity vector, 379–381

Y

Young's modulus, 202, 210

Answers to Problems

CHAPTER 2

2.1 (b) $S_{ij}S_{ij} = 28$, (c) $S_{ji}S_{ji} = S_{ij}S_{ij} = 28$, (d) $S_{jk}S_{kj} = 23$, (g) $S_{nm}a_m a_n = S_{mn}a_m a_n = 59$.

2.3 (a) $b_1 = 2, b_2 = 2, b_3 = 2$. (b) $s = 6$.

2.4 (c) $E_{ij} = B_{mi}C_{mk}F_{kj}$.

2.7 $i = 1 \rightarrow a_1 = \frac{\partial v_1}{\partial t} + v_1 \frac{\partial v_1}{\partial x_1} + v_2 \frac{\partial v_1}{\partial x_2} + v_3 \frac{\partial v_1}{\partial x_3}$, etc.

2.10 $d_1 = 6, d_2 = -3, d_3 = 2$.

2.12 (2) For $i = k$, $LS = RS = \begin{cases} 0 & \text{if } j \neq l \\ 0 & \text{if } j = l = i \\ 1 & \text{if } j = l \neq i \end{cases}$

2.20 (b) $[\mathbf{T}] = \begin{bmatrix} 0 & 0 & 1 \\ 0 & 0 & -1 \\ -1 & 1 & 0 \end{bmatrix}$.

2.21 (c) $\mathbf{T}(\mathbf{a} + \mathbf{b}) = 10\mathbf{e}_1$.

2.22 $[\mathbf{T}] = \begin{bmatrix} 2 & 0 & -1 \\ 0 & 1 & 3 \\ 1 & 3 & 0 \end{bmatrix}$.

2.23 $[\mathbf{T}] = \begin{bmatrix} -1/2 & 0 & 1/2 \\ -1/2 & 0 & 1/2 \\ 0 & 0 & 0 \end{bmatrix}$.

2.24 (a) $[\mathbf{T}] = \begin{bmatrix} 1 & 0 & 0 \\ 0 & -1 & 0 \\ 0 & 0 & 1 \end{bmatrix}$, (b) $[\mathbf{T}] = \begin{bmatrix} 1 & 0 & 0 \\ 0 & 1 & 0 \\ 0 & 0 & -1 \end{bmatrix}$.

2.25 (a) $[\mathbf{R}] = \begin{bmatrix} 1 & 0 & 0 \\ 0 & \cos \theta & -\sin \theta \\ 0 & \sin \theta & \cos \theta \end{bmatrix}$, (b) $[\mathbf{R}] = \begin{bmatrix} \cos \theta & 0 & \sin \theta \\ 0 & 1 & 0 \\ -\sin \theta & 0 & \cos \theta \end{bmatrix}$.

2.26 (b) $[\mathbf{T}] = \frac{1}{3} \begin{bmatrix} 1 & -2 & -2 \\ -2 & 1 & -2 \\ -2 & -2 & 1 \end{bmatrix}$, (c) $\mathbf{T}\mathbf{a} = -(3\mathbf{e}_1 + 2\mathbf{e}_2 + \mathbf{e}_3)$.

2.27 $[\mathbf{T}] = \frac{1}{3} \begin{bmatrix} 1 & -2 & -2 \\ -2 & 1 & -2 \\ -2 & -2 & 1 \end{bmatrix}$.

2 Answers to Problems

2.28 (b) $\mathbf{n} = (\mathbf{e}_1 + \mathbf{e}_2 + \mathbf{e}_3)/\sqrt{3}$.

2.29 $[\mathbf{T}] = \frac{1}{3} \begin{bmatrix} 1 + 2 \cos \theta & (1 - \cos \theta) - \sqrt{3} \sin \theta & (1 - \cos \theta) + \sqrt{3} \sin \theta \\ (1 - \cos \theta) + \sqrt{3} \sin \theta & (1 + 2 \cos \theta) & (1 - \cos \theta) - \sqrt{3} \sin \theta \\ (1 - \cos \theta) - \sqrt{3} \sin \theta & (1 - \cos \theta) + \sqrt{3} \sin \theta & (1 + 2 \cos \theta) \end{bmatrix}$.

2.30 (b) $\mathbf{R}^A = \sin \theta \mathbf{E}$.

2.31 (a) $[\mathbf{S}] = \begin{bmatrix} 1 & 0 & 0 \\ 0 & -1/\sqrt{2} & -1/\sqrt{2} \\ 0 & -1/\sqrt{2} & 1/\sqrt{2} \end{bmatrix}$, (b) $[\mathbf{T}] = \begin{bmatrix} 1 & 0 & 0 \\ 0 & -1/\sqrt{2} & 1/\sqrt{2} \\ 0 & 1/\sqrt{2} & 1/\sqrt{2} \end{bmatrix}$, (d) $[\mathbf{c}] = \begin{bmatrix} 1 \\ 1/\sqrt{2} \\ 5/\sqrt{2} \end{bmatrix}$.

2.37 $\mathbf{a} = 2\mathbf{e}'_1$.

2.38 (b) $\mathbf{a} = \mathbf{e}'_1 + \sqrt{3}\mathbf{e}'_2$.

2.39 $T'_{11} = 4/5$, $T'_{12} = -15/\sqrt{5}$, $T'_{31} = 2/5$.

2.40 (a) $[T'_{ij}] = [\mathbf{T}]' = \begin{bmatrix} 0 & -5 & 0 \\ -5 & 1 & 5 \\ 0 & 5 & 1 \end{bmatrix}$.

2.42 (b) $T_{ij}T_{ij} = 45$, (c) $[\mathbf{T}]' = \begin{bmatrix} 2 & 5 & 1 \\ 2 & 3 & 1 \\ 0 & 0 & 1 \end{bmatrix}$.

2.48 (a) $[\mathbf{T}^S] = \begin{bmatrix} 1 & 3 & 5 \\ 3 & 5 & 7 \\ 5 & 7 & 9 \end{bmatrix}$, $[\mathbf{T}^A] = \begin{bmatrix} 0 & -1 & -2 \\ 1 & 0 & -1 \\ 2 & 1 & 0 \end{bmatrix}$, (b) $\mathbf{t}^A = \mathbf{e}_1 - 2\mathbf{e}_2 + \mathbf{e}_3$.

2.50 (d) For $\lambda = 1$, $\mathbf{n} = [\alpha_1\mathbf{e}_1 + \alpha_2\mathbf{e}_2 - (\alpha_1 + \alpha_2)\mathbf{e}_3]/\sqrt{\alpha_1^2 + \alpha_2^2 + \alpha_3^2}$.

2.55 $\theta = 120^\circ$.

2.56 (c) For $\lambda = 1$, $\mathbf{n} = \pm\mathbf{e}_3$. (d) For $\lambda = -1$, $\mathbf{n} = \alpha_1\mathbf{e}_1 + \alpha_2\mathbf{e}_2$, $\alpha_1^2 + \alpha_2^2 = 1$, (e) $\theta = \pi$.

2.59 (a) For $\lambda_1 = 3$, $\mathbf{n}_1 = \pm\mathbf{e}_3$. For $\lambda_2 = -3$, $\mathbf{n}_2 = \pm(\mathbf{e}_1 - 2\mathbf{e}_2)/\sqrt{5}$.

2.60 (a) For $\lambda_1 = 3$, $\mathbf{n}_1 = \pm\mathbf{e}_1$. For $\lambda_2 = 4$, $\mathbf{n}_2 = \pm(\mathbf{e}_2 + \mathbf{e}_3)/\sqrt{2}$.

2.61 For $\lambda_1 = 0$, $\mathbf{n}_1 = \pm(\mathbf{e}_1 - \mathbf{e}_2)/\sqrt{2}$. For $\lambda_2 = \lambda_3 = 2$, $\mathbf{n} = \pm(\alpha\mathbf{e}_1 + \alpha\mathbf{e}_2 + \alpha_3\mathbf{e}_3)$, $2\alpha^2 + \alpha_3^2 = 1$.

2.65 (b) At $(0, 0, 0)$, $(d\phi/dr)_{\max} = |\nabla\phi| = 2$ in the direction of $\mathbf{n} = \mathbf{e}_3$.

At $(1, 0, 1)$, $(d\phi/dr)_{\max} = |\nabla\phi| = 17$ in the direction of $\mathbf{n} = (2\mathbf{e}_1 + 3\mathbf{e}_2 + 2\mathbf{e}_3)/\sqrt{17}$.

2.67 (a) $\mathbf{q} = -3k(\mathbf{e}_1 + \mathbf{e}_2)$, (b) $\mathbf{q} = -(3k\mathbf{e}_1 + 6k\mathbf{e}_2)$.

2.69 (a) $[\nabla\mathbf{v}]_{(1,1,0)} = 2[\mathbf{I}]$, (b) $(\nabla\mathbf{v})\mathbf{v} = 2\mathbf{e}_1$, (c) $\text{div } \mathbf{v} = 2$, $\text{curl } \mathbf{v} = 2\mathbf{e}_1$, (d) $d\mathbf{v} = 2ds(\mathbf{e}_1 + \mathbf{e}_3)$.

2.71 $[\nabla\mathbf{u}] = \begin{bmatrix} -A/r^2 & -B & 0 \\ B & A/r^2 & 0 \\ 0 & 0 & 0 \end{bmatrix}$.

2.72 $\operatorname{div} \mathbf{u} = 3A$.

2.73 $[\nabla \mathbf{u}] = \begin{bmatrix} A - 2B/r^3 & 0 & 0 \\ 0 & A + B/r^3 & 0 \\ 0 & 0 & A + B/r^3 \end{bmatrix}$.

2.77 $(\operatorname{div} \mathbf{T})_r = (\operatorname{div} \mathbf{T})_\theta = (\operatorname{div} \mathbf{T})_z = 0$.

CHAPTER 3

3.1 (b) $v_1 = \frac{kx_1}{1+kt}$, $v_2 = 0$, $v_3 = 0$.

3.2 (a) $v_1 = \alpha$, $v_2 = v_3 = 0$, $a_1 = a_2 = a_3 = 0$,
 (b) $\theta = A(\alpha t + X_1)$, $D\theta/Dt = A\alpha$, (c) $\theta = BX_2$, $D\theta/Dt = 0$.

3.3 (b) $v_1 = 0$, $v_2 = 2\beta X_1^2 t$, $v_3 = 0$ and $a_1 = 0$, $a_2 = 2\beta X_1^2$, $v_3 = 0$,
 (c) $v_1 = 0$, $v_2 = 2\beta x_1^2 t$, $v_3 = 0$ and $a_1 = 0$, $a_2 = 2\beta x_1^2$, $a_3 = 0$.

3.4 (b) $v_1 = 2\beta X_2^2 t$, $v_2 = kX_2$, $v_3 = 0$ and $a_1 = 2\beta X_2^2$, $a_2 = 0$, $a_3 = 0$,
 (c) $v_1 = 2\beta x_2^2 t / (1+kt)^2$, $v_2 = kx_2 / (1+kt)$, $v_3 = 0$, $a_1 = 2\beta x_2^2 / (1+kt)^2$, $a_2 = a_3 = 0$.

3.5 (b) $v_1 = k(s + X_1)$, $v_2 = 0$, $v_3 = 0$ and $a_1 = 0$, $a_2 = 0$, $a_3 = 0$,
 (c) $v_1 = k(s + x_1) / (1+kt)$, $v_2 = 0$, $v_3 = 0$ and $a_1 = 0$, $a_2 = 0$, $a_3 = 0$.

3.6 (b) For $(X_1, X_2, X_3) = (1, 3, 1)$ and $t = 2$, $v_1 = -4(3)^2(2) = -72$, $v_2 = -1$, $v_3 = 0$.
 (c) For $(x_1, x_2, x_3) = (1, 3, 1)$ and $t = 2$, $v_1 = -200$, $v_2 = -1$, $v_3 = 0$.

3.7 (a) For $(X_1, X_2, X_3) = (1, 1, 0)$ and $t = 2$, $v_1 = 2k$, $v_2 = 2k$, $v_3 = 0$.
 (b) For $(x_1, x_2, x_3) = (1, 1, 0)$ and $t = 2$, $v_1 = 2k / (1 + 4k)$, $v_3 = 0$.

3.8 (a) $t = 2 \rightarrow x_1 = 5$, $x_2 = 3$, $x_3 = 0$, (b) $X_1 = -3$, $X_2 = 1$, $X_3 = 2$,
 (c) $a_1 = 18$, $a_2 = 0$, $a_3 = 0$, (d) $a_1 = 2$, $a_2 = 0$, $a_3 = 0$.

3.9 (b) $a_i = 0$.

3.10 (a) $\mathbf{a} = -4x\mathbf{e}_x - 4y\mathbf{e}_y$, (b) $x^2 + y^2 = \text{constant} = X^2 + Y^2$.
 Or, $x = -Y \sin 2t + X \cos 2t$ and $y = Y \cos 2t + X \sin 2t$.

3.11 (a) $\mathbf{a} = k^2(x\mathbf{e}_x + y\mathbf{e}_y)$, (b) $x = Xe^{kt}$, $y = Ye^{-kt}$. Or $xy = XY$.

3.12 Material description: $\mathbf{a} = 2k^2(x^2 + y^2)(x\mathbf{e}_x + y\mathbf{e}_y)$.

3.14 (b) $a_1 = 0$, $a_2 = -\pi^2(\sin \pi t)(\sin \pi X_1)$, $a_3 = 0$.

3.15 (b) $\mathbf{a} = -(\alpha^2\sqrt{2}/4)\mathbf{e}_r$, $D\Theta/Dt = 2\alpha k$.

3.16 (b) $\mathbf{a} = -(\alpha^2\sqrt{2}/4)\mathbf{e}_r$, $D\Theta/Dt = 0$.

3.17 (b) $ds_1/dS_1 = (1/\sqrt{2})\sqrt{(1+k)^2 + 1} = ds_2/dS_2$,
 $\cos(\pi/2 - \gamma) = \sin \gamma = \{-(1+k)^2 + 1\} / \{(1+k)^2 + 1\}$.

4 Answers to Problems

(c) For $k = 1$, $ds_1/dS_1 = ds_2/dS_2 = \sqrt{5/2}$, $\sin \gamma = -3/5$.

For $k = 10^{-2}$, $ds_1/dS_1 = ds_2/dS_2 \approx 1.005$, $\gamma = -0.0099 \text{ rad}$. (d) $2E'_{12} = -0.01$.

3.19 (a) $[\mathbf{E}] = \begin{bmatrix} 0 & 0 & k/2 \\ 0 & k & 0 \\ k/2 & 0 & 0 \end{bmatrix}$, (b) $10^{-5}/2$.

3.20 (a) $E_{11} = 5k = 5 \times 10^{-4}$, $E_{22} = 2k = 2 \times 10^{-4}$, $2E_{12} = k = 10^{-4} \text{ rad}$.

3.21 (a) $E'_{11} = 10^{-4}/3$.

3.22 (a) $E'_{11} = (58/9) \times 10^{-4}$, (b) $2E'_{12} = (32/\sqrt{45}) \times 10^{-4} \text{ rad}$.

3.23 (a) $E'_{11} = (37/25) \times 10^{-4}$, (b) $2E''_{12} = (72/25) \times 10^{-4} \text{ rad}$.

3.24 (a) $I_1 = 11 \times 10^{-4}$, $I_2 = 31 \times 10^{-8}$, $I_3 = 17 \times 10^{-12}$.

3.25 $I_1 = 0$, $I_2 = -\tau^2$, $I_3 = 0$.

3.26 At $(1, 0, 0)$, $\lambda_{\max} = 3k = 3 \times 10^{-6}$.

3.27 (a) $\Delta(dV)/dV = 0$, (b) $k_1 = 2k_2$.

3.28 (b) At $(1, 2, 1)$, $E'_{11} = k$, (c) max elongation $= 4k$, (d) $\Delta V = k$.

3.32 $E_{11} = a$, $E_{22} = c$, $E_{12} = b - (a + c)/2$.

3.33 (a) $E_{12} = -100 \times 10^{-6}$. (b) For $\lambda_1 = 261.8 \times 10^{-6}$, $\theta = -31.7^\circ$, or $\mathbf{n} = 0.851\mathbf{e}_1 - 0.525\mathbf{e}_2$. For $\lambda_2 = 38.2 \times 10^{-6}$, $\theta = 58.3^\circ$, or $\mathbf{n} = 0.525\mathbf{e}_1 + 0.851\mathbf{e}_2$.

3.34 (a) $E_{12} = 0$, (b) Prin. strains are 10^{-3} in any direction lying on the plane of \mathbf{e}_1 and \mathbf{e}_2 .

3.35 $E_{11} = a$, $E_{22} = (2b + 2c - a)/3$, $E_{12} = (b - c)/\sqrt{3}$.

3.36 $E_{11} = 2 \times 10^{-6}$, $E_{22} = 1 \times 10^{-6}$, $E_{12} = [1/(2\sqrt{3})] \times 10^{-6}$.

3.37 $E_{11} = 2 \times 10^{-3}$, $E_{22} = 2 \times 10^{-3}$, $E_{12} = 0$.

3.38 (a) $[\mathbf{D}] = \begin{bmatrix} 0 & kx_2 & 0 \\ kx_2 & 0 & 0 \\ 0 & 0 & 0 \end{bmatrix}$, $[\mathbf{W}] = \begin{bmatrix} 0 & kx_2 & 0 \\ -kx_2 & 0 & 0 \\ 0 & 0 & 0 \end{bmatrix}$, (b) $D_{(n)(n)} = 3k$.

3.39 $D_{11} = -\alpha(1 + k)$; $D'_{11} = (1 + k)/2$.

3.40 (a) $D_{12} = (\pi \cos t \cos \pi x_1)/2$, $W_{12} = -W_{21} = -(\pi \cos t \cos \pi x_1)/2$.

(b) $D_{11} = 0$, $D_{22} = 0$, $D'_{11} = \pi/2$.

3.42 (a) $D_{rr} = -1/r^2$, $D_{\theta\theta} = 1/r^2$, other $D_{ij} = 0$; $[\mathbf{W}] = [\mathbf{0}]$. (b) $\mathbf{D}_{rr} = -1/r^2$.

3.43 At $r = 2$, $a_r = -18$, $a_\theta = 0$, (b) $[\mathbf{D}] = \begin{bmatrix} 0 & -1 \\ -1 & 0 \end{bmatrix}$.

3.44 (a) $a_r = -(Ar + B/r^2)^2 \sin^2 \theta / r$, $a_\theta = -\cos \theta \sin \theta (Ar + B/r^2)^2 / r$, $a_\phi = 0$.

(b) $D_{r\phi} = -(3B/2r^3) \sin \theta$, $D_{\theta\phi} = 0$.

3.45 $[\mathbf{W}] = 0$.

3.49 $k = 1$.

3.50 $f = g(\theta)/r$.

3.51 $v_\theta = -(k/2)\sin\theta/\sqrt{r}$.

3.53 $v_1 = f(x_2), \quad v_2 = 0$.

3.54 (a) $\rho = \rho_0(1 + kt)^{-\alpha/k}$, (b) $\rho = \rho^*x_0/x_1$.

3.55 $\rho = \rho_0 e^{-\alpha t^2}$.

3.60 (b) $2kX_1X_2 = f(X_2, X_3) + g(X_1, X_3)$.

3.62 $\left\{ \frac{\partial \rho}{\partial t} + v_r \frac{\partial \rho}{\partial r} + \frac{v_\theta}{r} \left(\frac{\partial \rho}{\partial \theta} \right) + v_z \frac{\partial \rho}{\partial z} \right\} + \rho \left(\frac{\partial v_r}{\partial r} + \frac{v_r}{r} + \frac{1}{r} \frac{\partial v_\theta}{\partial \theta} + \frac{\partial v_z}{\partial z} \right) = 0$.

3.63 (b) $[\mathbf{U}] = \begin{bmatrix} 1 & 0 & 0 \\ 0 & 2 & 0 \\ 0 & 0 & 3 \end{bmatrix}$, (c) $[\mathbf{B}] = \begin{bmatrix} 9 & 0 & 0 \\ 0 & 1 & 0 \\ 0 & 0 & 4 \end{bmatrix}$, (d) $[\mathbf{R}] = \begin{bmatrix} 0 & 0 & 1 \\ -1 & 0 & 0 \\ 0 & -1 & 0 \end{bmatrix}$,

(e) $[\mathbf{E}^*] = \begin{bmatrix} 0 & 0 & 0 \\ 0 & 3/2 & 0 \\ 0 & 0 & 4 \end{bmatrix}$, (f) $[\mathbf{e}^*] = \begin{bmatrix} 4/9 & 0 & 0 \\ 0 & 0 & 0 \\ 0 & 0 & 3/8 \end{bmatrix}$, (g) $\frac{\Delta V}{\Delta V_0} = 6$, (h) $d\mathbf{A} = -3\mathbf{e}_3$.

3.64 (b) $[\mathbf{U}] = \begin{bmatrix} 1 & 0 & 0 \\ 0 & 2 & 0 \\ 0 & 0 & 3 \end{bmatrix}$, (c) $[\mathbf{B}] = \begin{bmatrix} 4 & 0 & 0 \\ 0 & 9 & 0 \\ 0 & 0 & 1 \end{bmatrix}$, (d) $[\mathbf{R}] = \begin{bmatrix} 0 & 1 & 0 \\ 0 & 0 & 1 \\ 1 & 0 & 0 \end{bmatrix}$,

(e) $[\mathbf{E}^*] = \begin{bmatrix} 0 & 0 & 0 \\ 0 & 3/2 & 0 \\ 0 & 0 & 4 \end{bmatrix}$, (f) $[\mathbf{e}^*] = \begin{bmatrix} 3/8 & 0 & 0 \\ 0 & 4/9 & 0 \\ 0 & 0 & 0 \end{bmatrix}$, (g) $\frac{\Delta V}{\Delta V_0} = 6$, (h) $d\mathbf{A} = 3\mathbf{e}_1$.

3.65 (b) $[\mathbf{U}] = \begin{bmatrix} 1 & 0 & 0 \\ 0 & 2 & 0 \\ 0 & 0 & 3 \end{bmatrix}$, (c) $[\mathbf{B}] = \begin{bmatrix} 1 & 0 & 0 \\ 0 & 9 & 0 \\ 0 & 0 & 4 \end{bmatrix}$, (d) $[\mathbf{R}] = \begin{bmatrix} 1 & 0 & 0 \\ 0 & 0 & 1 \\ 0 & -1 & 0 \end{bmatrix}$,

(e) $[\mathbf{E}^*] = \begin{bmatrix} 0 & 0 & 0 \\ 0 & 3/2 & 0 \\ 0 & 0 & 4 \end{bmatrix}$, (f) $[\mathbf{e}^*] = \begin{bmatrix} 0 & 0 & 0 \\ 0 & 4/9 & 0 \\ 0 & 0 & 3/8 \end{bmatrix}$, (g) $\frac{\Delta V}{\Delta V_0} = 6$,

(h) $d\mathbf{A} = -3\mathbf{e}_3$.

3.66 (b) $[\mathbf{U}] = \begin{bmatrix} 1 & 0 & 0 \\ 0 & 2 & 0 \\ 0 & 0 & 3 \end{bmatrix}$, (c) $[\mathbf{B}] = \begin{bmatrix} 4 & 0 & 0 \\ 0 & 1 & 0 \\ 0 & 0 & 9 \end{bmatrix}$, (d) $[\mathbf{R}] = \begin{bmatrix} 0 & 1 & 0 \\ -1 & 0 & 0 \\ 0 & 0 & 1 \end{bmatrix}$,

(e) $[\mathbf{E}^*] = \begin{bmatrix} 0 & 0 & 0 \\ 0 & 3/2 & 0 \\ 0 & 0 & 4 \end{bmatrix}$, (f) $[\mathbf{e}^*] = \begin{bmatrix} 3/8 & 0 & 0 \\ 0 & 0 & 0 \\ 0 & 0 & 4/9 \end{bmatrix}$, (g) $\frac{\Delta V}{\Delta V_0} = 6$,

(h) $d\mathbf{A} = 3\mathbf{e}_1$.

6 Answers to Problems

3.67 (a) $[\mathbf{C}] = \begin{bmatrix} 1 & 3 & 0 \\ 3 & 10 & 0 \\ 0 & 0 & 1 \end{bmatrix}$. (b) For $\lambda_1 = 10.908326$, $\mathbf{n}_1 = 0.289785\mathbf{e}_1 + 0.957093\mathbf{e}_2$.

For $\lambda_2 = 0.0916735$, $\mathbf{n}_2 = 0.957093\mathbf{e}_1 - 0.289784\mathbf{e}_2$. For $\lambda_3 = 1$, $\mathbf{n}_3 = \mathbf{e}_3$,

(c) $[\mathbf{U}]_{\mathbf{n}_i} = \begin{bmatrix} 3.30277 & 0 & 0 \\ 0 & 0.302774 & 0 \\ 0 & 0 & 1 \end{bmatrix}$, (d) $[\mathbf{U}]_{\mathbf{e}_i} = \begin{bmatrix} 0.554704 & 0.832057 & 0 \\ 0.832057 & 3.05087 & 0 \\ 0 & 0 & 1 \end{bmatrix}$,
 $[\mathbf{U}^{-1}]_{\mathbf{e}_i} = \begin{bmatrix} 3.050852 & -0.832052 & 0 \\ -0.832052 & 0.554701 & 0 \\ 0 & 0 & 1 \end{bmatrix}$, (d) $[\mathbf{R}]_{\mathbf{e}_i} = \begin{bmatrix} 0.55470 & 0.83205 & 0 \\ -0.83205 & 0.55470 & 0 \\ 0 & 0 & 1 \end{bmatrix}$.

3.70 (a) 3, 2 and 0.6, (b) $(ds/dS) = \sqrt{13/2}$, (c) $\cos \theta = 0$. No change in angle.

3.71 (a) $[\mathbf{U}] = \frac{1}{\sqrt{5}} \begin{bmatrix} 2 & 1 & 0 \\ 1 & 3 & 0 \\ 0 & 0 & \sqrt{5} \end{bmatrix}$, (b) $\sqrt{C_{22}} = \sqrt{2}$, (c) $\frac{ds}{dS} = \sqrt{5/2}$, (d) $\cos \theta = \frac{1}{\sqrt{2}}$.

3.72 (a) $[\mathbf{U}] = \frac{1}{\sqrt{2}} \begin{bmatrix} 1 & 1 & 0 \\ 1 & 3 & 0 \\ 0 & 0 & \sqrt{2} \end{bmatrix}$, (b) $\sqrt{C_{22}} = \sqrt{5}$, (c) $\frac{ds}{dS} = \sqrt{5}$, (d) $\cos \theta = \frac{2}{\sqrt{5}}$.

3.77 $B_{rr}^{-1} = \left(\frac{\partial r_o}{\partial r}\right)^2 + \left(\frac{r_o \partial \theta_o}{\partial r}\right)^2 + \left(\frac{\partial z_o}{\partial r}\right)^2$, $B_{\theta\theta}^{-1} = \left(\frac{\partial r_o}{r \partial \theta}\right)^2 + \left(\frac{r_o \partial \theta_o}{r \partial \theta}\right)^2 + \left(\frac{\partial z_o}{r \partial \theta}\right)^2$.

3.80 $C_{r_o \theta_o}^{-1} = \left(\frac{r_o \partial \theta_o}{\partial r}\right) \left(\frac{\partial r_o}{\partial r}\right) + \left(\frac{r_o \partial \theta_o}{r \partial \theta}\right) \left(\frac{\partial r_o}{r \partial \theta}\right) + \left(\frac{r_o \partial \theta_o}{\partial z}\right) \left(\frac{\partial r_o}{\partial z}\right)$.

3.81 $B_{r\theta} = \left(\frac{\partial r}{\partial X}\right) \left(\frac{r \partial \theta}{\partial X}\right) + \left(\frac{\partial r}{\partial Y}\right) \left(\frac{r \partial \theta}{\partial Y}\right) + \left(\frac{\partial r}{\partial Z}\right) \left(\frac{r \partial \theta}{\partial Z}\right)$.

3.82 $B_{r\theta}^{-1} = \left(\frac{\partial X}{\partial r}\right) \left(\frac{\partial X}{r \partial \theta}\right) + \left(\frac{\partial Y}{\partial r}\right) \left(\frac{\partial Y}{r \partial \theta}\right) + \left(\frac{\partial Z}{\partial r}\right) \left(\frac{\partial Z}{r \partial \theta}\right)$.

3.84 (a) $[\mathbf{B}] = \begin{bmatrix} 1 & 0 & 0 \\ 0 & 1 + (rk)^2 & rk \\ 0 & rk & 1 \end{bmatrix}$, (b) $[\mathbf{C}] = \begin{bmatrix} 1 & 0 & 0 \\ 0 & 1 & rk \\ 0 & rk & 1 + (rk)^2 \end{bmatrix}$.

3.85 (a) $[\mathbf{B}] = \begin{bmatrix} (a/r)^2 & 0 & 0 \\ 0 & (r/a)^2 & 0 \\ 0 & 0 & 1 \end{bmatrix}$, (b) $\det \mathbf{B} = 1$, no change of volume.

3.86 $[\mathbf{C}] = \begin{bmatrix} (f(X))^2 & 0 & 0 \\ 0 & (g(Y))^2 & 0 \\ 0 & 0 & (h(Z))^2 \end{bmatrix}$.

CHAPTER 4

- 4.1** (a) 1 MPa, 4 MPa, 0 MPa. (b) 3.61 MPa, 5.39 MPa, 5.83 MPa.
- 4.2** (a) $\mathbf{t} = (1/3)(5\mathbf{e}_1 + 6\mathbf{e}_2 + 5\mathbf{e}_3)$. (b) $T_n = 3$ MPa, $T_s = 0.745$ MPa.
- 4.3** (a) $\mathbf{t} = 3.47\mathbf{e}_1 - 2.41\mathbf{e}_2$. (b) $T_n = 2.21$ MPa, $T_s = 3.60$ MPa.
- 4.4** $\mathbf{t} = 25\sqrt{3}\mathbf{e}_1 + 25\mathbf{e}_2 - 25\sqrt{3}\mathbf{e}_3$.
- 4.5** (a) $\mathbf{t} = \mathbf{e}_3$. (b) $n_1^2 - n_2^2 = 0$, including $\mathbf{n} = \mathbf{e}_3$, $\mathbf{n} = (\mathbf{e}_1 + \mathbf{e}_2)/\sqrt{2}$, $\mathbf{n} = (\mathbf{e}_1 - \mathbf{e}_2)/\sqrt{2}$.
- 4.6** $T'_{11} = -6.43$ MPa, $T'_{13} = 18.6$ MPa.
- 4.7** (a) $\mathbf{t}_{\mathbf{e}_1} = \alpha x_2 \mathbf{e}_1 + \beta \mathbf{e}_2$. (b) $\mathbf{F}_R = 0\mathbf{e}_1 + 4\beta \mathbf{e}_2$, $\mathbf{M}_O = -(4\alpha/3)\mathbf{e}_3$.
- 4.8** (a) $\mathbf{t}_{\mathbf{e}_1} = \alpha x_2^2 \mathbf{e}_1$. (b) $\mathbf{F}_R = (4\alpha/3)\mathbf{e}_1$, $\mathbf{M}_O = 0$.
- 4.9** (a) $\mathbf{t}_{\mathbf{e}_1} = \alpha \mathbf{e}_1 + \alpha x_3 \mathbf{e}_2$. (b) $\mathbf{F}_R = 4\alpha \mathbf{e}_1$, $\mathbf{M}_O = -(4\alpha/3)\mathbf{e}_1$.
- 4.10** (a) $\mathbf{t}_{\mathbf{n}_1} = 0$, $\mathbf{t}_{\mathbf{n}_2} = \alpha x_3 \mathbf{e}_2 - \alpha x_2 \mathbf{e}_3$, $\mathbf{t}_{\mathbf{n}_3} = -\alpha x_3 \mathbf{e}_2 + \alpha x_2 \mathbf{e}_3$. (b) $\mathbf{F}_R = 0$, $\mathbf{M}_O = 8\pi\alpha \mathbf{e}_1$.
- 4.11** (b) $\mathbf{F}_R = 0$, $\mathbf{M}_O = -\pi/(2\sqrt{2})$.
- 4.12** (a) $\text{tr } \mathbf{S} = 0$. (b) $[\mathbf{S}] = \begin{bmatrix} 0 & 500 & -200 \\ 500 & -300 & 400 \\ -200 & 400 & 300 \end{bmatrix} \text{ kPa}$.
- 4.13** (a) 4.
- 4.14** (b) $T_{12} = T_{21}$.
- 4.17** $f_{\max} = 2$.
- 4.21** (a) $T_s = 0$. (b) For $T_{\max} = 100$ MPa, $\mathbf{n}_1 = (\mathbf{e}_1 + \mathbf{e}_2)/\sqrt{2}$. For $T_{\min} = -100$ MPa, $\mathbf{n}_2 = (\mathbf{e}_1 - \mathbf{e}_2)/\sqrt{2}$. (c) $(T_s)_{\max} = 100$ MPa, on the planes \mathbf{e}_1 and \mathbf{e}_2 .
- 4.23** (a) $(T_s)_{\max} = 150$ MPa, $\mathbf{n} = (\mathbf{e}_1 \pm \mathbf{e}_3)/\sqrt{2}$, (b) $T_n = 250$ MPa.
- 4.24** $T_{33} = 1$ and $T_{11} = 1$.
- 4.25** (a) $T_n = 800/9 = 88.89$ kPa, $T_s = 260$ kPa, (b) $(T_s)_{\max} = 300$ kPa.
- 4.26** (a) $\mathbf{t}_n = (5/\sqrt{2})(\mathbf{e}_1 + \mathbf{e}_2)$, (b) $T_n = 5$ MPa, (d) $(T_n)_{\max} = 5$ MPa, $\mathbf{n}_1 = (1/\sqrt{2})(\mathbf{e}_1 + \mathbf{e}_2)$, $(T_n)_{\min} = -3$ MPa, $\mathbf{n}_2 = (1/\sqrt{2})(\mathbf{e}_1 - \mathbf{e}_2)$. $(T_s)_{\max} = 4$ MPa, on $\mathbf{n} = \mathbf{e}_1$ and $\mathbf{n} = \mathbf{e}_2$.
- 4.27** (a) For $\lambda_1 = \tau$, $\mathbf{n}_1 = (1/\sqrt{2})(\mathbf{e}_1 + \mathbf{e}_2)$. For $\lambda_2 = -\tau$, $\mathbf{n}_2 = (1/\sqrt{2})(\mathbf{e}_1 - \mathbf{e}_2)$. For $\lambda_3 = 0$, $\mathbf{n}_3 = \mathbf{e}_3$. (b) $(T_s)_{\max} = \tau$, $\mathbf{n} = \mathbf{e}_1$ and $\mathbf{n} = \mathbf{e}_2$.

8 Answers to Problems

4.29 $T_{12} - T_{21} = M_3^*$, $T_{13} - T_{31} = M_2^*$ and $T_{23} - T_{32} = M_1^*$.

4.30 (b) $T_{12} = 2x_1 - x_2 + 3$.

4.31 $T_{33} = (1 + \rho g/\alpha)x_3 + f(x_1, x_2)$.

4.32 (a) $C = -1$, (b) $A = 1, B = 2$.

4.36 $\frac{T_{\theta r}}{r} + \frac{\partial T_{\theta r}}{\partial r} + \frac{T_{r\theta}}{r} + \frac{1}{r} \frac{\partial T_{\theta\theta}}{\partial \theta} + \frac{\partial T_{\theta z}}{\partial z} + \rho B_\theta = \rho a_\theta$.

4.39 $B = (p_o - p_i)r_i^2 r_o^2 / (r_o^2 - r_i^2)$, $A = (p_i r_i^2 - p_o r_o^2) / (r_o^2 - r_i^2)$.

4.41 $A = -(p_o r_o^3 - p_i r_i^3) / (r_o^3 - r_i^3)$, $B = -(p_o - p_i)r_o^3 r_i^3 / [2(r_o^3 - r_i^3)]$.

4.42 (a) $[\mathbf{T}_o] = \begin{bmatrix} 1000/16 & 0 & 0 \\ 0 & 0 & 0 \\ 0 & 0 & 0 \end{bmatrix} MPa$, $\mathbf{t}_o = (1000/16)\mathbf{e}_1$.

(b) $[\tilde{\mathbf{T}}] = \begin{bmatrix} 1000/256 & 0 & 0 \\ 0 & 0 & 0 \\ 0 & 0 & 0 \end{bmatrix} MPa$, $\tilde{\mathbf{t}} = (1000/256)\mathbf{e}_1$.

4.44 (a) $dV = 1/4$, $d\mathbf{A} = (1/16)\mathbf{e}_1$,

(b) $[\mathbf{T}_o] = \begin{bmatrix} 100/16 & 0 & 0 \\ 0 & 0 & 0 \\ 0 & 0 & 0 \end{bmatrix} MPa$, $\mathbf{t}_o = (100/16)\mathbf{e}_1 MPa$.

(c) $[\tilde{\mathbf{T}}] = \begin{bmatrix} 100/64 & 0 & 0 \\ 0 & 0 & 0 \\ 0 & 0 & 0 \end{bmatrix} MPa$, $\tilde{\mathbf{t}} = (100/64)\mathbf{e}_1 MPa$, $d\tilde{\mathbf{f}} = \left(\frac{100}{64}\right)\mathbf{e}_1$.

4.45 (a) $dV = dV_o = 1$, $d\mathbf{A} = \mathbf{e}_1 - k\mathbf{e}_2$,

(b) $[\mathbf{T}_o] = \begin{bmatrix} -100k & 100 & 0 \\ 100 & 0 & 0 \\ 0 & 0 & 0 \end{bmatrix} MPa$, $\mathbf{t}_o = 100(-k\mathbf{e}_1 + \mathbf{e}_2) MPa$, $\mathbf{t} = \frac{100}{\sqrt{1+k^2}}(-k\mathbf{e}_1 + \mathbf{e}_2)$.

(c) $[\tilde{\mathbf{T}}] = \begin{bmatrix} -200k & 100 & 0 \\ 100 & 0 & 0 \\ 0 & 0 & 0 \end{bmatrix} MPa$, $\tilde{\mathbf{t}} = 100(-2k\mathbf{e}_1 + \mathbf{e}_2) MPa$, $d\tilde{\mathbf{f}} = 100(-2k\mathbf{e}_1 + \mathbf{e}_2)$.

4.46 (a) $dV = 8dV_o = 8$. $d\mathbf{A} = 4\mathbf{e}_1$

(b) $[\mathbf{T}_o] = \begin{bmatrix} 400 & 0 & 0 \\ 0 & 400 & 0 \\ 0 & 0 & 400 \end{bmatrix} MPa$, $\mathbf{t}_o = 400\mathbf{e}_1 MPa$, $\mathbf{t} = 100\mathbf{e}_1 MPa$.

(c) $[\tilde{\mathbf{T}}] = \begin{bmatrix} 200 & 0 & 0 \\ 0 & 200 & 0 \\ 0 & 0 & 200 \end{bmatrix} MPa$, $\tilde{\mathbf{t}} = 200\mathbf{e}_1 MPa$, $d\tilde{\mathbf{f}} = 200\mathbf{e}_1$.

CHAPTER 5

5.3 $E_Y/\lambda \rightarrow 0, \mu \rightarrow E_Y/3.$

5.4 $\mu = \frac{E_Y}{2(1+\nu)}, \quad k = \frac{2\mu(1+\nu)}{3(1-2\nu)}.$

5.9 $\lambda = 81.7 \text{ GPa } (11.8 \times 10^6 \text{ psi}), \quad \mu = 38.4 \text{ GPa } (5.56 \times 10^6 \text{ psi}), \quad k = 107.3 \text{ GPa } (15.6 \times 10^6 \text{ psi}).$

5.10 $\nu = 0.27, \quad \lambda = 89.1 \text{ GPa } (12.9 \times 10^6 \text{ psi}), \quad k = 140 \text{ GPa } (20.3 \times 10^6 \text{ psi}).$

5.11 $[\mathbf{T}] = \begin{bmatrix} 17.7 & 1.9 & 4.75 \\ 1.9 & 18.4 & 0 \\ 4.75 & 0 & 16.0 \end{bmatrix} \text{ MPa}.$

5.13 (a) $[\mathbf{E}] = \begin{bmatrix} 0.483 & 0.253 & 0.380 \\ 0.253 & -1.41 & 0 \\ 0.380 & 0 & 1.12 \end{bmatrix} \times 10^{-3},$

(b) $e = 0.193 \times 10^{-3}, \Delta V = 24.1 \times 10^{-3} \text{ cm}^3.$

5.14 $\Delta V = 2.96 \times 10^{-3}.$

5.17 (a) $T_{11} = T_{22} = T_{33} = 0, \quad T_{12} = T_{21} = 2\mu k x_3, \quad T_{13} = T_{31} = \mu k(2x_1 + x_2), \quad T_{23} = T_{32} = \mu k(x_1 - 2x_2).$

5.19 (a) $[\mathbf{T}] = 2k \begin{bmatrix} \lambda x_3 & \mu x_3 & \mu x_2 \\ \mu x_3 & \lambda x_3 & \mu x_1 \\ \mu x_2 & \mu x_1 & (\lambda + 2\mu)x_3 \end{bmatrix}.$

5.21 For $\nu = 1/3, c_L/c_T = 2; \quad \nu = 0.49, c_L/c_T = 7.14; \quad \nu = 0.499, c_L/c_T = 22.4.$

5.24 (c) $\alpha = 1,$

(d) $\beta = n\pi/(2\ell), n = 1, 3, 5 \dots$

5.25 (c) $\alpha = 1,$

(d) $\beta = n\pi/\ell, n = 1, 2, 3 \dots$

5.28 (d) $\beta = n\pi/\ell, n = 1, 2, 3 \dots$

5.30 (a) $u_1 = \frac{3\varepsilon}{5} \sin \left[\frac{2\pi}{\ell} f \right], u_2 = \frac{4\varepsilon}{5} \sin \left[\frac{2\pi}{\ell} f \right], f(x_1, x_2 t) = \left(\frac{3x_1}{5} + \frac{4x_2}{5} - c_L t - \eta \right).$

5.32 (a) $\alpha_2 = \alpha_3 = 0, \varepsilon_2 = \varepsilon_1, \quad \text{and} \quad \text{(b)} \alpha_3 = 31.17^\circ, \varepsilon_2 = 0.742\varepsilon_1, \varepsilon_3 = 0.503\varepsilon_1.$

5.35 (b) $\varepsilon_3/\varepsilon_1 = -\sin 2\alpha_1/\cos(\alpha_1 - \alpha_3), \varepsilon_2/\varepsilon_1 = \cos(\alpha_1 + \alpha_3)/\cos(\alpha_1 - \alpha_3).$

5.38 (a) $u_1 = \alpha \left(\cos \frac{\omega x_1}{c_L} + \tan \frac{\omega \ell}{c_L} \sin \frac{\omega x_1}{c_L} \right) \cos \omega t,$

(b) $\omega \ell / c_L = n\pi/2, n = 1, 3, 5 \dots$

5.40 (a) $u_3 = \alpha [\cos(\omega x_1 / c_T) - \cot(\omega \ell / c_T) \sin(\omega x_1 / c_T)] \cos \omega t,$

(b) $\omega = n\pi c_T / \ell, n = 1, 2, 3 \dots$

5.42 (a) $(T_n)_{\max} = 71.4 \times 10^6 \text{ N}, (T_s)_{\max} = 23.7 \times 10^6 \text{ N}, \quad \text{(b)} \delta_\ell = 1.39 \times 10^{-3} \text{ m}.$

10 Answers to Problems

- 5.44** (a) $T_n = \sigma \cos^2 \alpha$, $T_s = \sigma \sin 2\alpha/2$,
 (b) (i) $\alpha = \pi/2$, $T_s = T_n = 0$, and (ii) $\alpha = \pi/4$, $T_s = T_n = \sigma/2$,
 (c) $\sigma \leq 2\tau_o/\sin 2\alpha$.
- 5.46** (a) $T_{11}^o = 2\sigma/3$, $T_{22}^o = T_{33}^o = -\sigma/3$, $T_{12}^o = T_{13}^o = T_{23}^o = 0$,
 (b) $I_1 = 0$, $I_2 = -\sigma^2/3$, $I_3 = 2\sigma^3/27$.
- 5.49** $M_1 = M_t \ell_2/(\ell_1 + \ell_2)$, $M_2 = M_t \ell_1/(\ell_1 + \ell_2)$.
- 5.51** $(T_n)_{\max} = [\sigma + \sqrt{\sigma^2 + 4\beta^2 r^2}]/2$, $T_s = [\sqrt{\sigma^2 + 4\beta^2 r^2}]/2$, $\sigma = P/A$, $\beta = M_t/I_p$.
- 5.53** (a) $(M_t)_{ell}/(M_t)_{cir} = 2$, (b) $\alpha'_{ell}/\alpha'_{cir} = 5/16$.
- 5.54** (b) $C = \alpha'/6a$, (c) $T_{12} = 0$, $T_{13} = 0$ at all three corners; along $x_3 = 0$,
 $T_{12} = 0$, $T_{13} = (\mu\alpha'/2a)(2ax_2 + x_2^2)$, (d) $T_s = (3a/2)\mu\alpha'$ at $(x_2, x_3) = (a, 0)$.
- 5.57** $M_t = \left(\frac{\mu\alpha'}{3}\right)(2a)^3(2b) \left[1 - \frac{192}{\pi^5} \left(\frac{a}{b}\right) \sum_{n=1,3,5}^{\infty} \frac{1}{n^5} \tan h \frac{n\pi b}{2a}\right]$.
- 5.60** Neutral axis in the direction of $M_2\mathbf{e}_2 + (I_{22}/I_{33})M_3\mathbf{e}_3$.
- 5.63** (b) $T_{11} = 2\alpha_3$, $T_{12} = -\alpha_2$, $T_{22} = 2\alpha_1$,
 (c) $x_1 = 0$, $\mathbf{t} = -2\alpha_3\mathbf{e}_1 + \alpha_2\mathbf{e}_2$, $x_1 = b$, $\mathbf{t} = 2\alpha_3\mathbf{e}_1 - \alpha_2\mathbf{e}_2$,
 (d) $T_{33} = 2v(\alpha_3 + \alpha_1)$, $T_{13} = T_{23} = 0$, $E_{i3} = 0$, $E_{11} = 2(1/E_Y)[(1 - v^2)\alpha_3 - v(1 + v)\alpha_1]$,
 (e) $T_{i3} = 0$, $E_{13} = E_{23} = 0$, $E_{33} = -2(v/E_Y)(\alpha_3 + \alpha_1)$, $E_{11} = 2(1/E_Y)(\alpha_3 - v\alpha_1)$.
- 5.66** (b) $T_{11} = 2\alpha x_1 + 6x_1x_2$, $T_{22} = 0$, $T_{12} = -2\alpha x_2 - 3x_2^2$,
 (c) $\alpha = -3c/2$, (d) $\mathbf{t}_{x_1=0} = 3x_2(x_2 - c)\mathbf{e}_2$, $\mathbf{t}_{x_1=b} = 3b(2x_2 - c)\mathbf{e}_1 - 3x_2(x_2 - c)\mathbf{e}_2$, $\mathbf{t}_{x_2=0} = 0$.
- 5.67** $u_1 = \frac{Px_1^2x_2}{2E_YI} + \frac{vPx_2^3}{6E_YI} - \left(\frac{Px_2^3}{6\mu I}\right) + \left(\frac{P}{2\mu I}\right)\left(\frac{h}{2}\right)^2 x_2 - c_1x_2 + c_3$.
- 5.69** (a) $T_{12} = 2A_m \left[\frac{\{-(\lambda_m c)\cos h \lambda_m c\} \sin h \lambda_m x_2 + \sin h \lambda_m c (\lambda_m x_2 \cos h \lambda_m x_2)}{\sin h 2\lambda_m c + 2\lambda_m c} \right] \sin \lambda_m x_1$.
- 5.72** $u_r = \frac{(1+v)}{E_Y} \left[-\frac{A}{r} + 2B(1-2v)r \ln r - Br + 2C(1-2v)r \right] + H \sin \theta + G \cos \theta$,
 $u_\theta = (1/E_Y)[4Br\theta(1-v)(1+v)] + H \cos \theta - G \sin \theta + Fr$.
- 5.74** r, r^{-1}, r^3 and $r \ln r$.
- 5.84** $T_{rr} = -\frac{(1-2v)z}{R^3} + \frac{3r^2z}{R^5}$, $T_{\theta\theta} = -\frac{(1-2v)z}{R^3}$, $T_{rz} = \frac{(1-2v)r}{R^3} + \left(\frac{3rz^2}{R^5}\right)$,
 $T_{zz} = \frac{3z^3}{R^5} + (1-2v)\frac{z}{R^3}$.
- 5.87** $T_{xx} = -\frac{F_z}{2\pi} \left[\frac{3x^2z}{R^5} - \frac{(1-2v)z}{R^3} + \frac{(1-2v)}{R(R+z)} - \frac{(1-2v)}{R(R+z)} \left\{ \frac{1}{R} \frac{x^2}{(R+z)} + \frac{x^2}{R^2} \right\} \right]$.

$$5.88 \quad T_{zz} = \frac{q_0 z^3}{(r_0^2 + z^2)^{3/2}} - q_0.$$

$$5.101 \quad C_{11} = \frac{1}{\Delta E_2 E_3} (1 - v_{32} v_{23}), \quad C_{12} = \frac{1}{\Delta E_2 E_3} (v_{21} + v_{31} v_{23}), \quad C_{13} = \frac{1}{\Delta E_2 E_3} (v_{31} + v_{21} v_{32}),$$

$$C_{23} = \frac{1}{\Delta E_1 E_3} (v_{32} + v_{31} v_{12}), \quad \Delta = \frac{[1 - 2v_{13} v_{21} v_{32} - v_{13} v_{31} - v_{23} v_{32} - v_{21} v_{12}]}{E_1 E_2 E_3}.$$

$$5.112 \quad B_{rr} = (\alpha/r)^2, \quad B_{\theta\theta} = (rc)^2, \quad B_{zz} = 1, \quad B_{r\theta} = 0, \quad B_{rz} = 0, \quad B_{\theta z} = 0.$$

$$5.113 \quad B_{rr} = \lambda_1^2, \quad B_{r\theta} = B_{rz} = 0, \quad B_{\theta\theta} = \lambda_1^2 + (rK)^2, \quad B_{zz} = \lambda_3^2, \quad B_{z\theta} = B_{\theta z} = \lambda_3 r K.$$

CHAPTER 6

$$6.1 \quad R_B = 5.1 \times 10^4 N.$$

$$6.2 \quad h = 2.48 m.$$

$$6.3 \quad h_2 = (\rho_1 h_1 - \rho_3 h_3) / \rho_2.$$

$$6.5 \quad (b) \quad F_x = \gamma(2r^2 L). \quad F_x \text{ is } 2r/3 \text{ above the ground. } F_y \text{ is } 4r/3\pi \text{ left of the diameter.}$$

$$6.6 \quad p - p_a = \rho(g + a)h.$$

$$6.8 \quad h = a\ell/g.$$

$$6.10 \quad h_1 - h_2 = \omega^2(r_1^2 - r_2^2)/(2g).$$

$$6.12 \quad (A) \text{ for } n \neq 1, \quad p^{(n-1)/n} = p_0^{-1/(n-1)} [p_0 - \{(n-1)/n\} \rho_0 g (z - z_0)]^{n/(n-1)}.$$

$$(B) \text{ for } n = 1, \quad p = p_0 \exp[-\rho_0 p_0^{-1/n} g (z - z_0)].$$

$$6.14 \quad (b) \quad T_n = \mu k - p, \quad T_s^2 = 0, \quad (c) \text{ any plane } (n_1, 0, n_3) \text{ and } (n_1, n_2, 0).$$

$$6.16 \quad (a) \quad (-T_n) - p = 44\mu/5, \quad (b) \quad T_s = 8\mu/5.$$

$$6.20 \quad (a) \quad x_2 = \alpha_2, \quad (b) \quad x_1 = \frac{1 + kX_2 t}{1 + kX_2 t_0} X_1 \text{ and } x_2 = X_2.$$

$$6.22 \quad (a) \quad x_1^2 + x_2^2 = \alpha_1^2 + \alpha_2^2, \quad (b) \quad x_1^2 + x_2^2 = X_1^2 + X_2^2, \text{ time history:}$$

$$x_1 = X_2 \sin \omega t + X_1 \cos \omega t, \quad x_2 = X_2 \cos \omega t - X_1 \sin \omega t.$$

$$6.23 \quad (a) \quad \theta = \theta_0, \quad (b) \quad \theta = \Theta, \text{ time history: } r^2 = R^2 + Qt/(\pi).$$

$$6.26 \quad v = (\alpha/2\mu)(x_2 d - x_2^2) + v_0 x_2/d, \quad Q = \alpha d^3/(12\mu) + v_0 d^2/(2d).$$

$$6.27 \quad \mu v = \rho g \sin \theta (d - x_2/2) x_2.$$

$$6.29 \quad \mu_1 v^{(t)} = -\alpha \left[\frac{x_2^2}{2} - \frac{b}{2} \left(\frac{\mu_2 - \mu_1}{\mu_1 + \mu_2} \right) x_2 - b^2 \left(\frac{\mu_1}{\mu_1 + \mu_2} \right) \right].$$

$$6.32 \quad (b) \quad v = \frac{1}{4\mu} \frac{dp}{dz} \left[r^2 + \frac{(a^2 - b^2)}{\ln(b/a)} \ln r + \frac{(b^2 \ln a - a^2 \ln b)}{\ln(b/a)} \right].$$

12 Answers to Problems

6.34 $A = \beta a^2 b^2 / \{2(a^2 + b^2)\}$, $B = -A$.

6.36 wave length $= \sqrt{2\pi}/10^3 = 2.51 \times 10^{-3} m$.

6.38 (b) $A = Q_m/(2\pi)$.

6.40 $\Theta = -\frac{\mu^3}{12\kappa\alpha^2} \left[\frac{v_o}{d} + \left(\frac{\alpha}{2\mu} \right) (d - 2x_2) \right]^4 + Cx_2 + D$.
 $D = \Theta_o + \frac{\mu^3}{12\kappa\alpha^2} \left(\frac{v_o}{d} + \frac{\alpha d}{2\mu} \right)^4$.

6.42 $\Theta = -\frac{\mu B^2}{\kappa r^2} + C \ln r + D$, $C = \left(\frac{r_o^2 - r_i^2}{r_i^2 r_o^2} \right) \left(\frac{\mu B^2}{\kappa} \right) / \left(\ln \frac{r_i}{r_o} \right)$.

6.44 (b) $T_{11} = -p + 2\mu k$, $T_{22} = -p - 2\mu k$, $T_{33} = -p$, $T_{12} = T_{13} = T_{23} = 0$,
 (c) $a_1 = k^2 x_1$, $a_2 = k^2 x_2$, $a_3 = 0$, (d) $p = -(\rho/2)(v_1^2 + v_2^2) + p_o$, (f) $\Phi = 4\mu k^2$,
 (h) the nonslip boundary condition at $x_2 = 0$ is not satisfied for a viscous fluid.

6.46 Ans. $\zeta = -(1/\mu)(\partial p/\partial x_1)x_2 \mathbf{e}_3$.

6.48 (c) $\left(\frac{dy}{dx} \right)_{\varphi=\text{constant}} \left(\frac{dy}{dx} \right)_{\psi=\text{constant}} = -1$: (d) $\zeta = -\left(\frac{\partial^2 \psi}{\partial y^2} + \frac{\partial^2 \psi}{\partial x^2} \right) \mathbf{e}_z$.

6.49 $\frac{\partial^2 \psi}{\partial y^2} + \frac{\partial^2 \psi}{\partial x^2} = 0$.

6.51 $Q = A_1 A_2 \sqrt{2[(p_1 - p_2) - \rho gh] / [\rho(A_1^2 - A_2^2)]}$.

CHAPTER 7

7.1 $\int \mathbf{v} \cdot \mathbf{n} dS = \int \text{div } \mathbf{v} dV = 16$.

7.3 $\int \text{div } \mathbf{v} dV = \int \mathbf{v} \cdot \mathbf{n} dS = 64\pi$.

7.9 (b) $m = 3\rho_o e^{-\alpha(t-t_o)} A$, $dm/dt = -3\alpha\rho_o e^{-\alpha(t-t_o)} A$.

7.11 (b) $m = kA\rho_o \ln 3$, $dm/dt = 0$.

7.14 (a) $\frac{d\mathbf{P}}{dt} = -\frac{9}{2}\alpha^2 A\rho_o e^{-\alpha(t-t_o)} \mathbf{e}_1$, (b) $9A\rho_o \alpha^2 e^{-\alpha(t-t_o)}$, (c) $\mathbf{F} = \frac{9}{2}A\rho_o \alpha^2 e^{-\alpha(t-t_o)} \mathbf{e}_1$.

7.15 (a) $\mathbf{P} = 2\rho_o k\alpha A \mathbf{e}_1$, (b) $2k\rho_o A \alpha^2$, (c) $\mathbf{F} = 2k\rho_o A \alpha^2 \mathbf{e}_1$.

7.17 $(\rho C^2 \pi r_o^6/3) \mathbf{e}_1$, $(\pi \rho C^2 r_o^6/4) \mathbf{e}_1$.

7.19 $gx = x \frac{d^2 x}{dt^2} + \left(\frac{dx}{dt} \right)^2$.

7.21 Force from water to the bend is $\mathbf{F}_w = 1100\mathbf{e}_1 - 282\mathbf{e}_2N$.

7.22 $\rho Av_0^2 \mathbf{e}_1$.

7.24 Force on the vane is $\mathbf{F}_{\text{vane}} = \rho A(v_0 - v)^2[(1 - \cos \theta)\mathbf{e}_1 - \sin \theta \mathbf{e}_2]$.

CHAPTER 8

8.3 $S = G\varepsilon + \eta \frac{d\varepsilon}{dt}$, $S/\varepsilon_0 = GH(t) + \eta\delta(t)$.

8.4 (b) $\frac{S}{\varepsilon_0} = \frac{\eta_0^2 G}{(\eta + \eta_0)^2} e^{\frac{-Gt}{\eta_0}} + \frac{\eta\eta_0}{(\eta + \eta_0)} \delta(t)$.

8.5 $S_{12} = \mu v_0(1 - e^{-t/\lambda})$.

8.8 $G' = \int_{\lambda=0}^{\infty} \frac{\lambda^2 \omega^2 H(\lambda)}{\lambda(1 + \lambda^2 \omega^2)} d\lambda$, $G'' = \int_{\lambda=0}^{\infty} \frac{\lambda \omega H(\lambda)}{\lambda(1 + \lambda^2 \omega^2)} d\lambda$.

8.11 (b) $[\mathbf{C}_t] = \begin{bmatrix} 1 & 0 & 0 \\ 0 & 1 & 0 \\ 0 & 0 & 1 \end{bmatrix} + \begin{bmatrix} 0 & k & 0 \\ k & 0 & 0 \\ 0 & 0 & 0 \end{bmatrix} (\tau - t) + \begin{bmatrix} 2k^2 & 0 & 0 \\ 0 & 0 & 0 \\ 0 & 0 & 0 \end{bmatrix} \frac{(\tau - t)^2}{2}$, $k \equiv dv/dx_1$.

8.12 (b) $[\mathbf{C}_t] = \begin{bmatrix} e^{-2k(\tau-t)} & 0 & 0 \\ 0 & e^{2k(\tau-t)} & 0 \\ 0 & 0 & 1 \end{bmatrix} =$
 $[\mathbf{I}] + (\tau - t) \begin{bmatrix} -2k & 0 & 0 \\ 0 & 2k & 0 \\ 0 & 0 & 0 \end{bmatrix} + \begin{bmatrix} 4k^2 & 0 & 0 \\ 0 & 4k^2 & 0 \\ 0 & 0 & 0 \end{bmatrix} \frac{(\tau - t)^2}{2} + \begin{bmatrix} -8k^3 & 0 & 0 \\ 0 & 8k^3 & 0 \\ 0 & 0 & 0 \end{bmatrix} \frac{(\tau - t)^3}{3!} + \dots$

8.13 (b) $[\mathbf{C}_t] = \begin{bmatrix} e^{2k(\tau-t)} & 0 & 0 \\ 0 & e^{2k(\tau-t)} & 0 \\ 0 & 0 & e^{-4k(\tau-t)} \end{bmatrix} = [\mathbf{I}] + (\tau - t) \begin{bmatrix} 2k & 0 & 0 \\ 0 & 2k & 0 \\ 0 & 0 & -4k \end{bmatrix}$
 $+ \begin{bmatrix} 4k^2 & 0 & 0 \\ 0 & 4k^2 & 0 \\ 0 & 0 & 16k^2 \end{bmatrix} \frac{(\tau - t)^2}{2} + \begin{bmatrix} 8k^3 & 0 & 0 \\ 0 & 8k^3 & 0 \\ 0 & 0 & -64k^3 \end{bmatrix} \frac{(\tau - t)^3}{3!} + \dots$

8.14 (a) $x' = x_1 \cosh k(\tau - t) + x_2 \sinh k(\tau - t)$, $x'' = x_1 \sinh k(\tau - t) + x_2 \cosh k(\tau - t)$,

(b) $[\mathbf{C}_t] = \begin{bmatrix} \cosh^2\{k(\tau - t)\} + \sinh^2\{k(\tau - t)\} & \sinh\{2k(\tau - t)\} & 0 \\ \sinh\{2k(\tau - t)\} & \sinh^2\{k(\tau - t)\} + \cosh^2\{k(\tau - t)\} & 0 \\ 0 & 0 & 1 \end{bmatrix}$
 $= [\mathbf{I}] + \begin{bmatrix} 0 & 2k & 0 \\ 2k & 0 & 0 \\ 0 & 0 & 0 \end{bmatrix} (\tau - t) + \begin{bmatrix} 4k^2 & 0 & 0 \\ 0 & 4k^2 & 0 \\ 0 & 0 & 0 \end{bmatrix} \frac{(\tau - t)^2}{2} + \begin{bmatrix} 0 & 8k^3 & 0 \\ 8k^3 & 0 & 0 \\ 0 & 0 & 0 \end{bmatrix} \frac{(\tau - t)^3}{6} + \dots$

$$8.20 \text{ (a) } [\mathbf{A}_1] = \begin{bmatrix} 0 & k(r) & 0 \\ k(r) & 0 & 0 \\ 0 & 0 & 0 \end{bmatrix}, \quad k = \left(\frac{dv}{dr} - \frac{v(r)}{r} \right).$$

$$\text{(b) } (\nabla \mathbf{A}_1)_{rr\theta} = -\frac{2k}{r}, (\nabla \mathbf{A}_1)_{r\theta\theta} = 0, (\nabla \mathbf{A}_1)_{rz\theta} = 0, (\nabla \mathbf{A}_1)_{\theta r\theta} = 0, \\ (\nabla \mathbf{A}_1)_{\theta\theta\theta} = \frac{2k}{r}, (\nabla \mathbf{A}_1)_{\theta z\theta} = 0, (\nabla \mathbf{A}_1)_{zr\theta} = 0, (\nabla \mathbf{A}_1)_{z\theta\theta} = 0, (\nabla \mathbf{A}_1)_{zz\theta} = 0.$$

$$\text{(c) } \mathbf{A}_2 = \begin{bmatrix} 2k^2 & 0 & 0 \\ 0 & 0 & 0 \\ 0 & 0 & 0 \end{bmatrix}.$$

$$8.23 \quad \mu \equiv \frac{S_{12}}{k} = - \int_0^\infty s f_2(s) ds, \quad \sigma_1 = S_{11} - S_{22} = -k^2 \int_0^\infty s^2 f_2(s) ds, \quad \sigma_2 = S_{22} - S_{33} = 0.$$

$$8.27 \text{ (a) Corotational stress rate is: } \left[\overset{\circ}{\mathbf{T}} \right] = \begin{bmatrix} \mu k^2 & 0 \\ 0 & -\mu k^2 \end{bmatrix},$$

$$\text{(c) } \overset{\circ}{\mathbf{T}} = \mu k^2 \begin{bmatrix} \cos 2\omega t & \sin 2\omega t \\ \sin 2\omega t & -\cos 2\omega t \end{bmatrix}, \quad \text{(d) } \left[\overset{\circ}{\mathbf{T}}^* \right] = [\mathbf{Q}] \left[\overset{\circ}{\mathbf{T}} \right] [\mathbf{Q}]^T.$$

$$8.28 \text{ (b) The corotational derivative of } \mathbf{T}: \rho k (v_2^2 - v_1^2) \mathbf{I}.$$

$$8.30 \quad [\mathbf{T}] = -p[\mathbf{I}] + \phi_1(k^2/4, 0) \begin{bmatrix} 0 & k/2 & 0 \\ k/2 & 0 & 0 \\ 0 & 0 & 0 \end{bmatrix} + \phi_2(k^2/4, 0) \begin{bmatrix} k^2/4 & 0 & 0 \\ 0 & k^2/4 & 0 \\ 0 & 0 & 0 \end{bmatrix}.$$

$$8.36 \quad S_{12} = \frac{\mu k}{A(k)}, \quad \sigma_1 \equiv S_{11} - S_{22} = \frac{2\lambda\mu k^2}{A(k)}, \quad \sigma_2 = S_{22} - S_{33} = -\frac{\lambda\mu k^2(1+\alpha)}{A(k)}, \quad A(k) = \left[1 + (1-\alpha^2)(\lambda k)^2 \right].$$

$$8.37 \quad \eta(k) = S_{12}/k = \mu, \quad \sigma_1 = T_{11} - T_{22} = 2\mu k^2(\lambda_1 - \lambda_2), \quad \sigma_2 = T_{22} - T_{33} = 0.$$

$$8.38 \quad \eta(k) = \frac{S_{12}}{k} = \frac{\mu(1 + \lambda_2\mu_0 k^2)}{(1 + \lambda_1\mu_0 k^2)}, \quad \sigma_1 = T_{11} - T_{22} = \frac{2\mu k^2(\lambda_1 - \lambda_2)}{(1 + \lambda_1\mu_0 k^2)}, \quad \sigma_2 = T_{22} - T_{33} = 0.$$

$$8.40 \text{ (a) } S_{zr} = \tau(k), \quad S_{zz} - S_{rr} = \sigma_1(k), \quad S_{rr} - S_{\theta\theta} = \sigma_2(k), \quad S_{z\theta} = S_{r\theta} = 0.$$