

# اصول اساسی توربین گاز

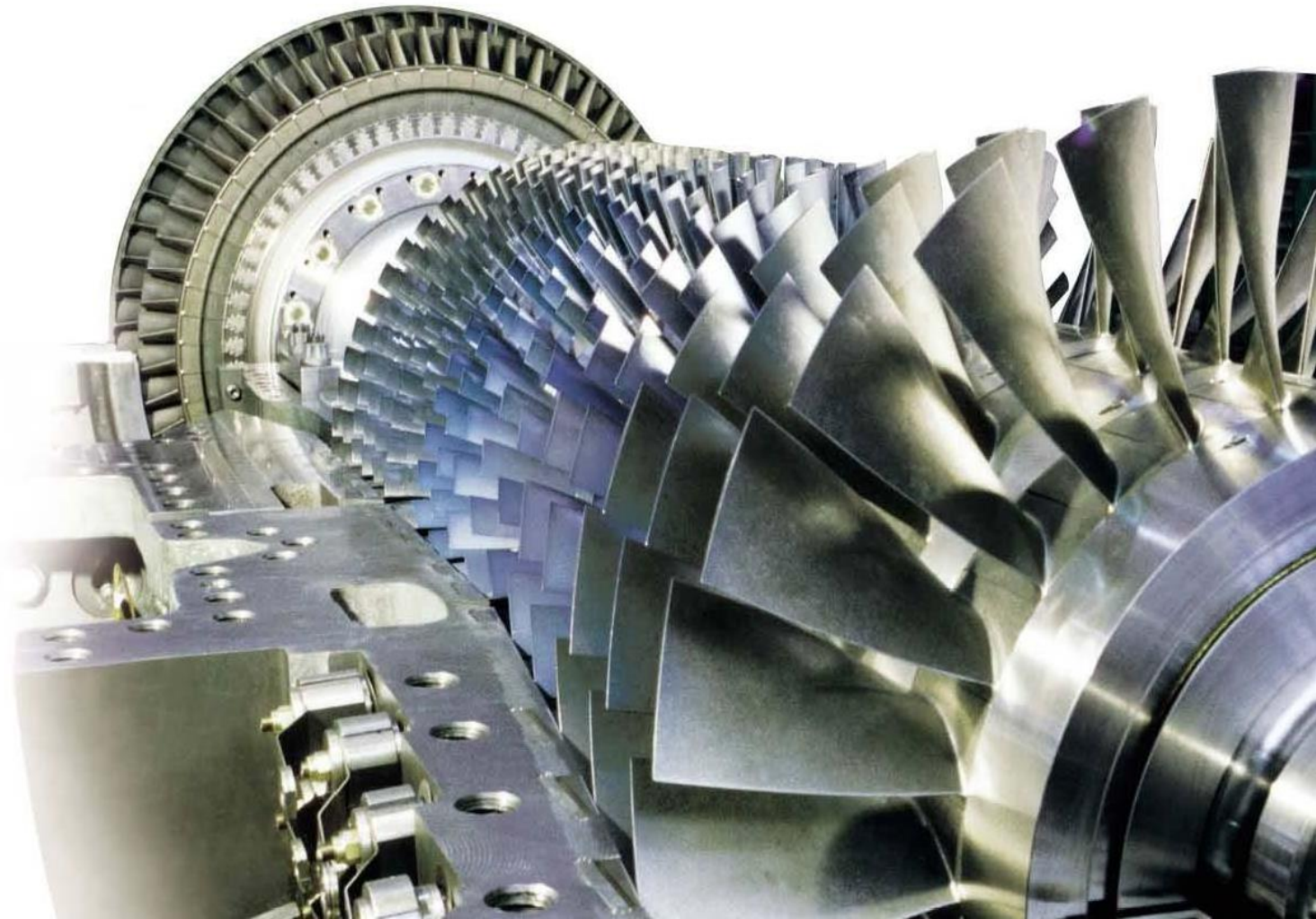

ارائه دهنده:

غلامرضا برات زاده

[gbk7961@gmail.com](mailto:gbk7961@gmail.com)

09126876992

# سیکل هوایی برایتون

- سیال عامل هوا است.
- هوا گاز کامل است.
- همه فرآیندها بازگشت پذیر داخلی هستند.
- حرارت مخصوص هوا ثابت است.

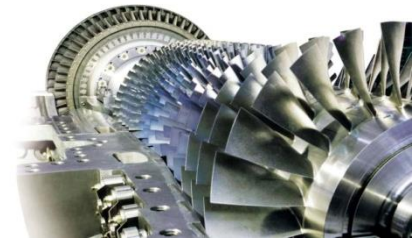
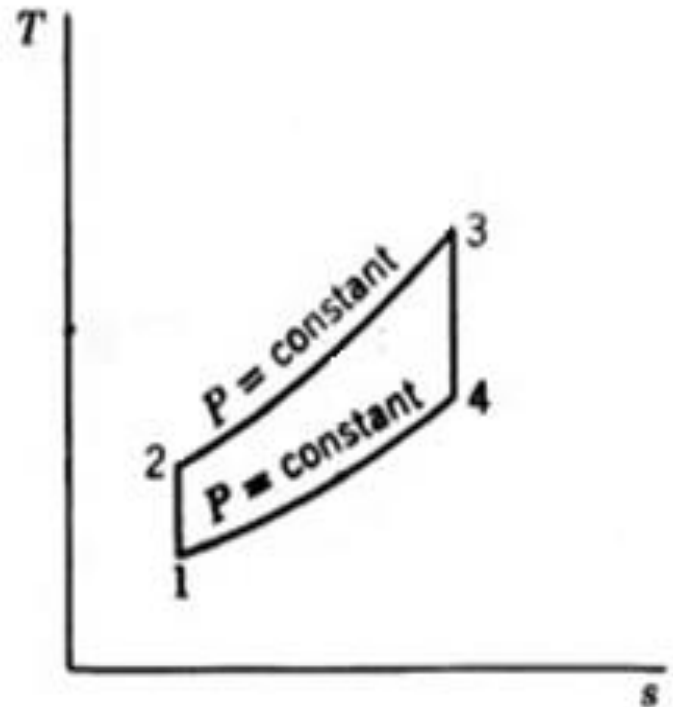
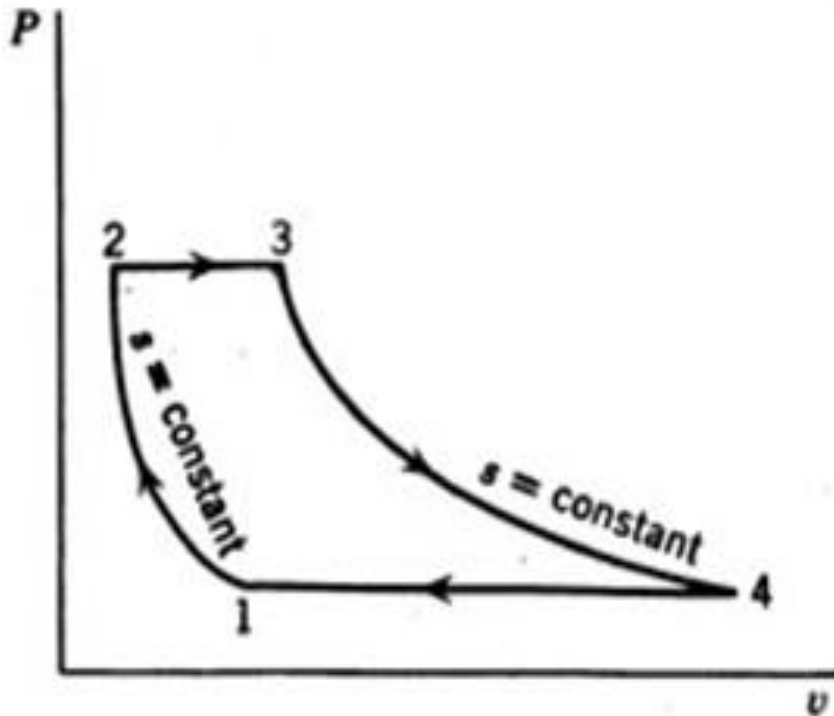

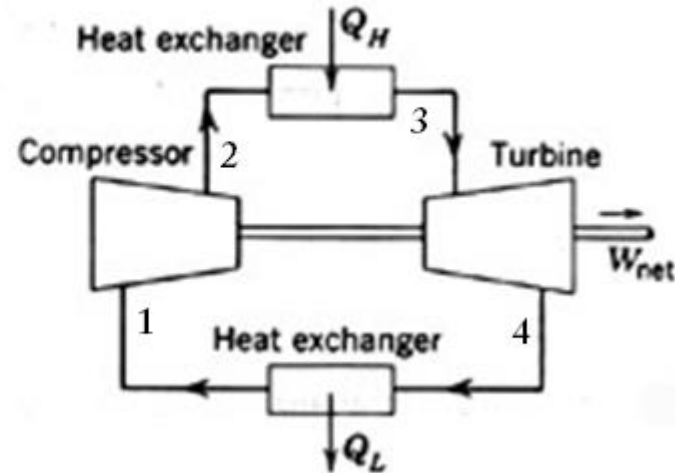
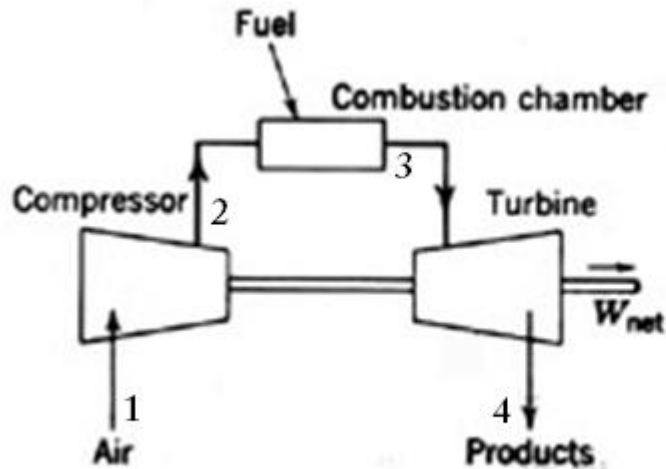

$$\eta_{th} = 1 - \frac{1}{r_P^{\left(\frac{K-1}{K}\right)}}$$

$$K = \frac{C_p}{C_v}$$

$$r_P = \frac{P_2}{P_1}$$

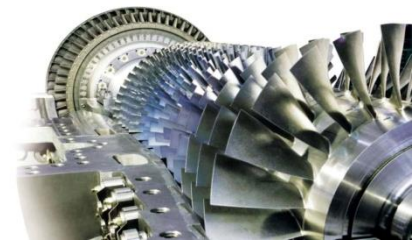

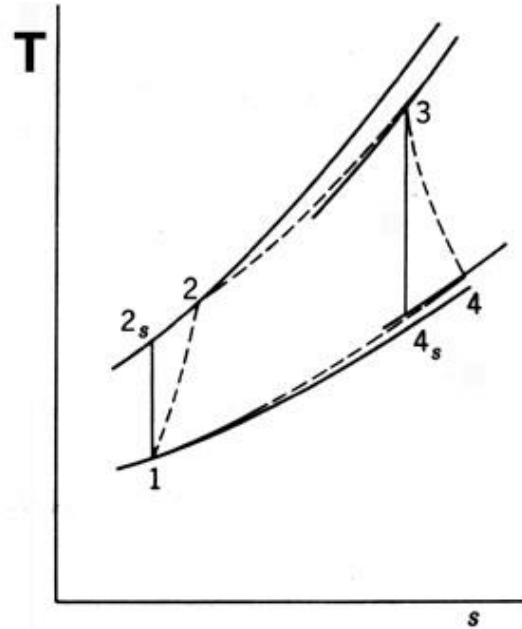

$$\eta_{comp} = \frac{h_{2s} - h_1}{h_2 - h_1}$$

$$\eta_{turb} = \frac{h_3 - h_4}{h_3 - h_{4s}}$$

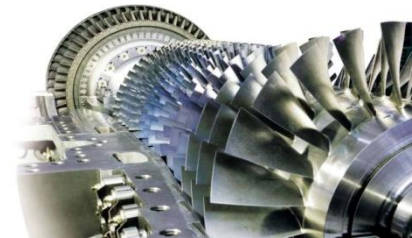



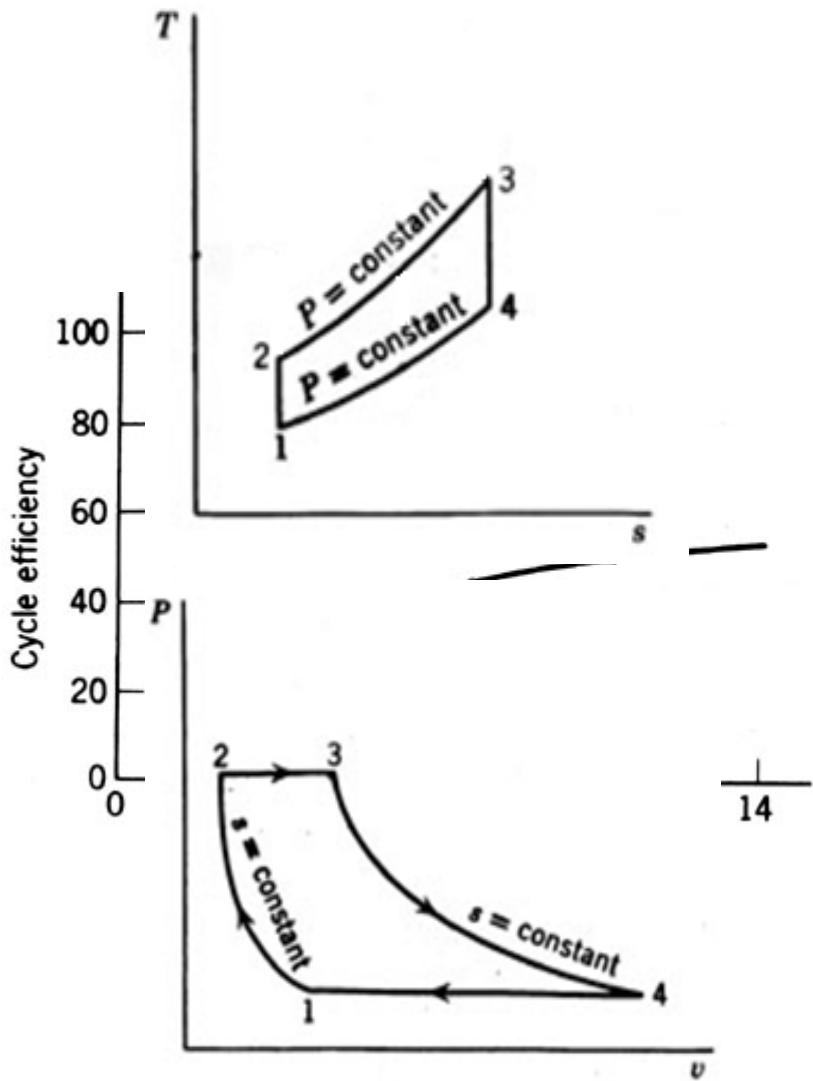

- افزایش نسبت تراکم
- کاهش دمای ورودی
- افزایش دمای حداکثر سیکل
- کاهش فشار خروجی توربین
- استفاده از بازیاب
- استفاده از میان سردکن

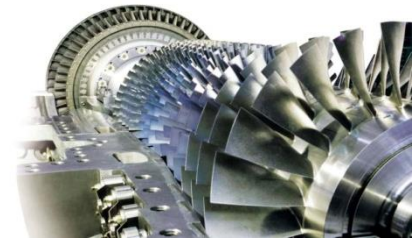

# استفاده از بازیاب (ایده آل)

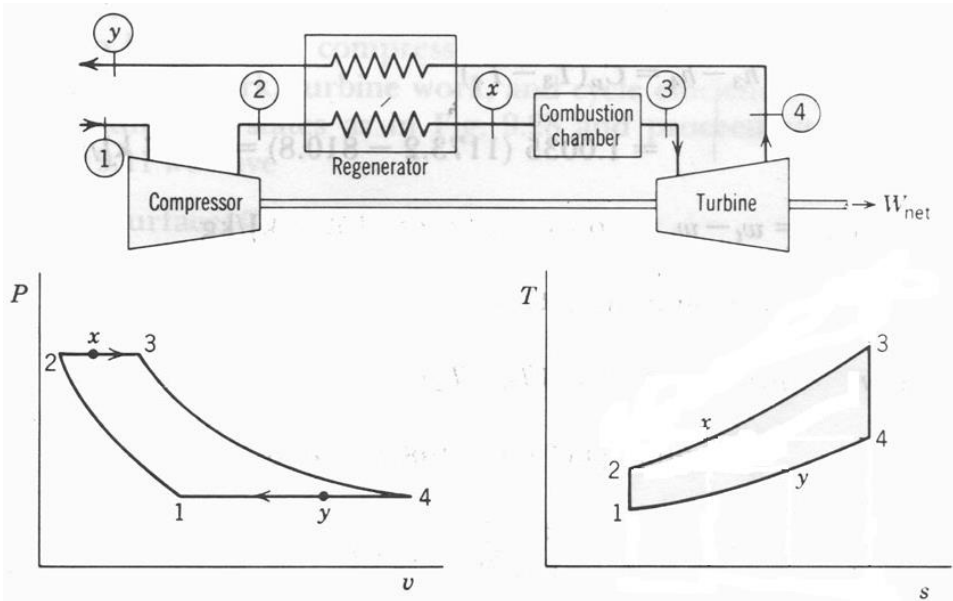

$$\eta_{th} = \frac{W_{net}}{q_H} = \frac{W_t - W_c}{q_H}$$

$$T_4 = T_x$$

$$\eta_{th} = 1 - \frac{T_1}{T_3} \times \left( \frac{P_2}{P_1} \right)^{\frac{K-1}{K}}$$

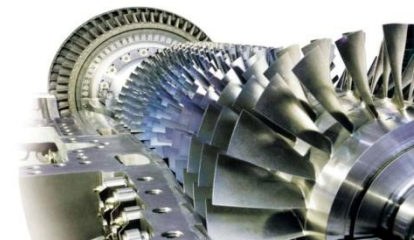
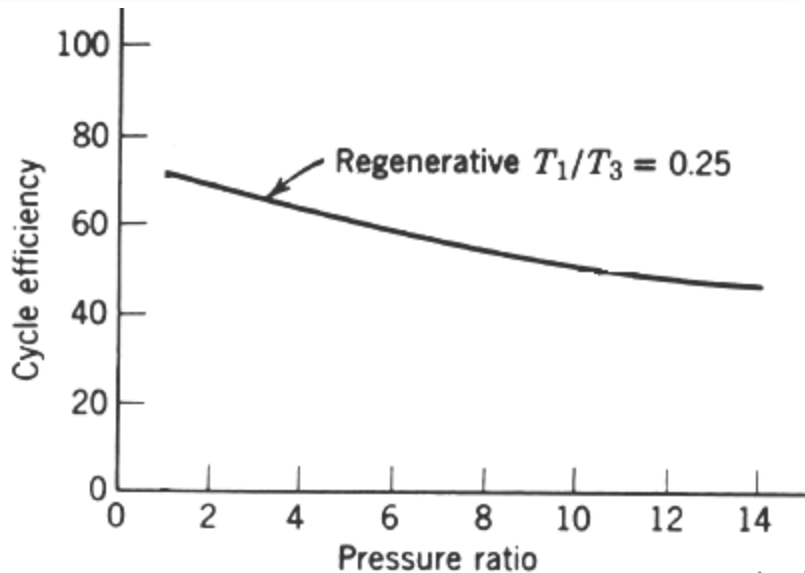

# استفاده از میان سرد کن و بازیاب چند مرحله ای

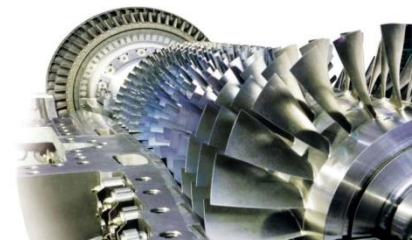
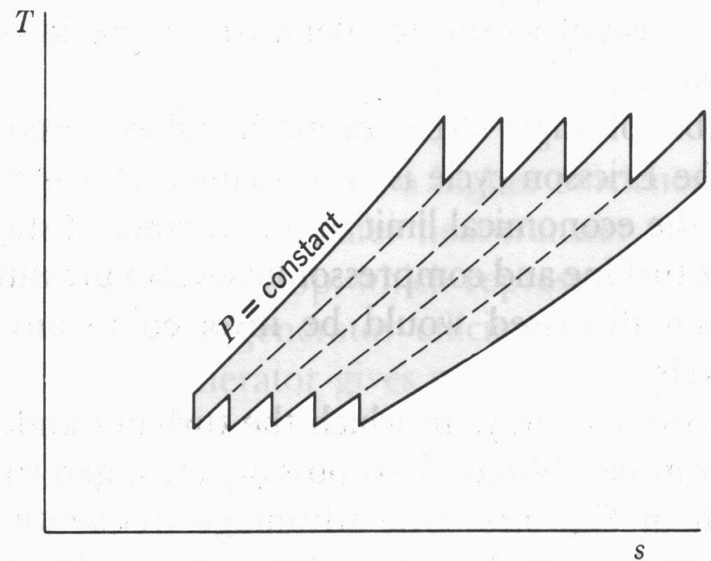
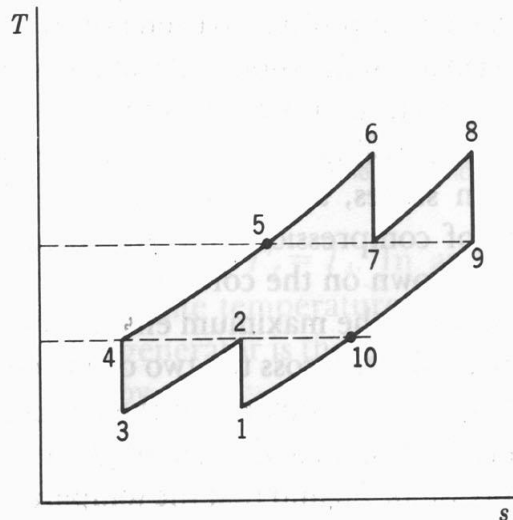
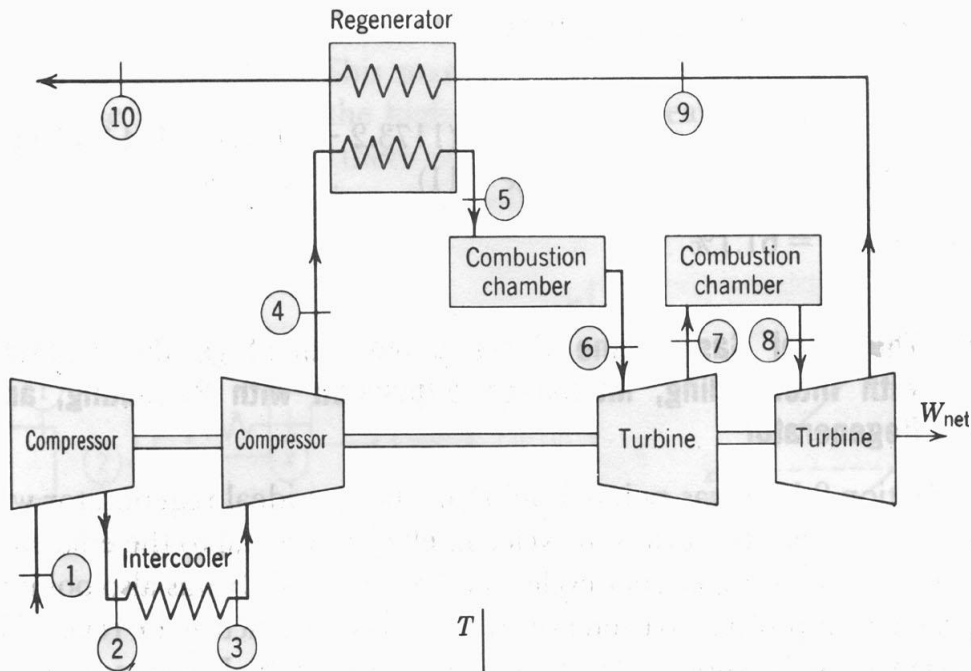

- تک محور
- دو محور

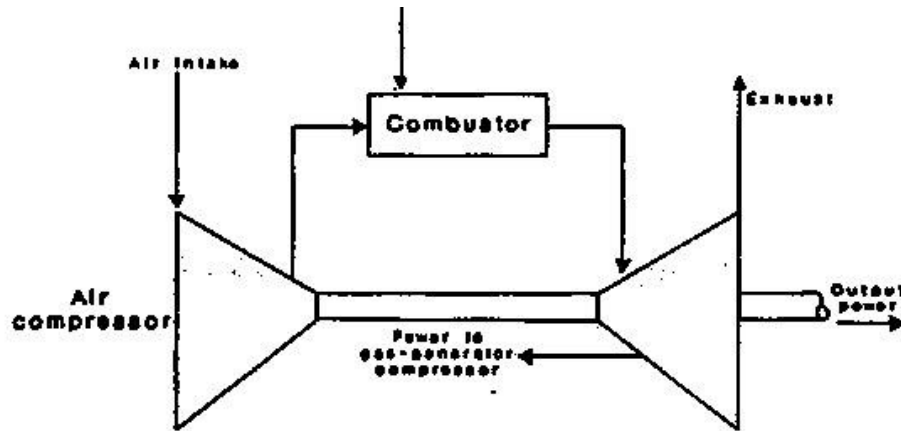

Single-shaft turbine

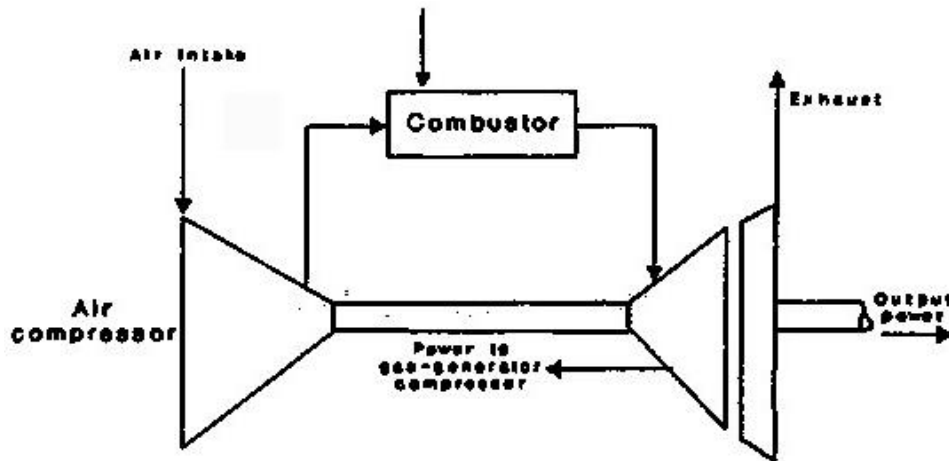

Two-shaft turbine

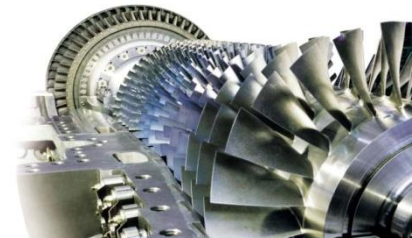



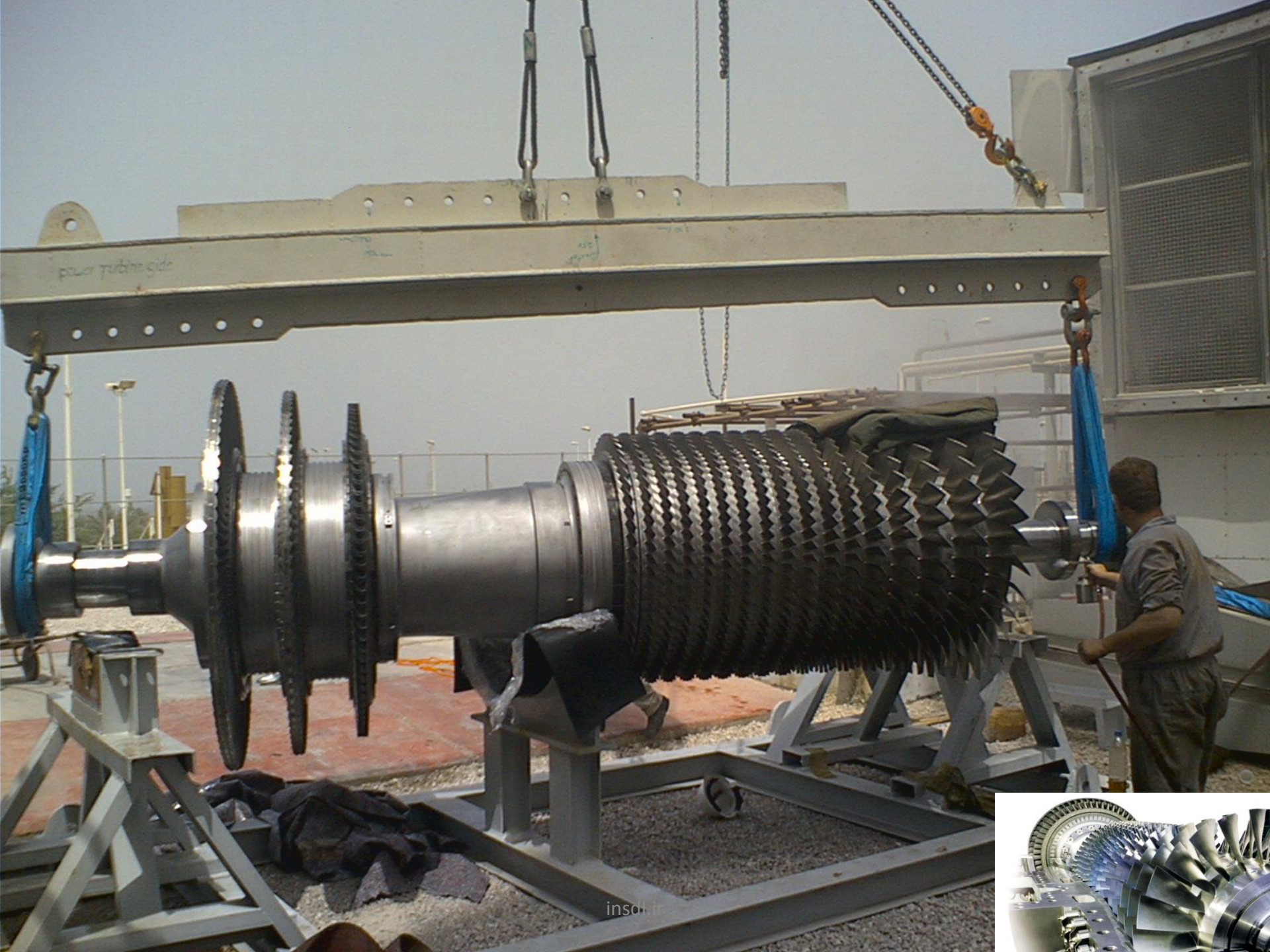

insol





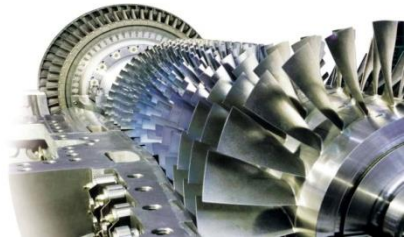
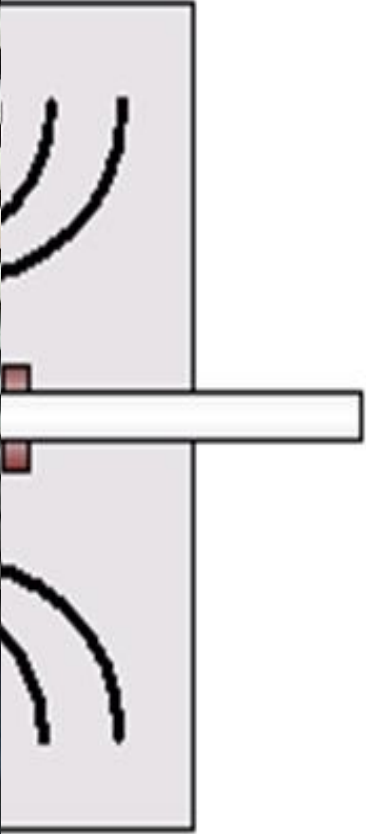
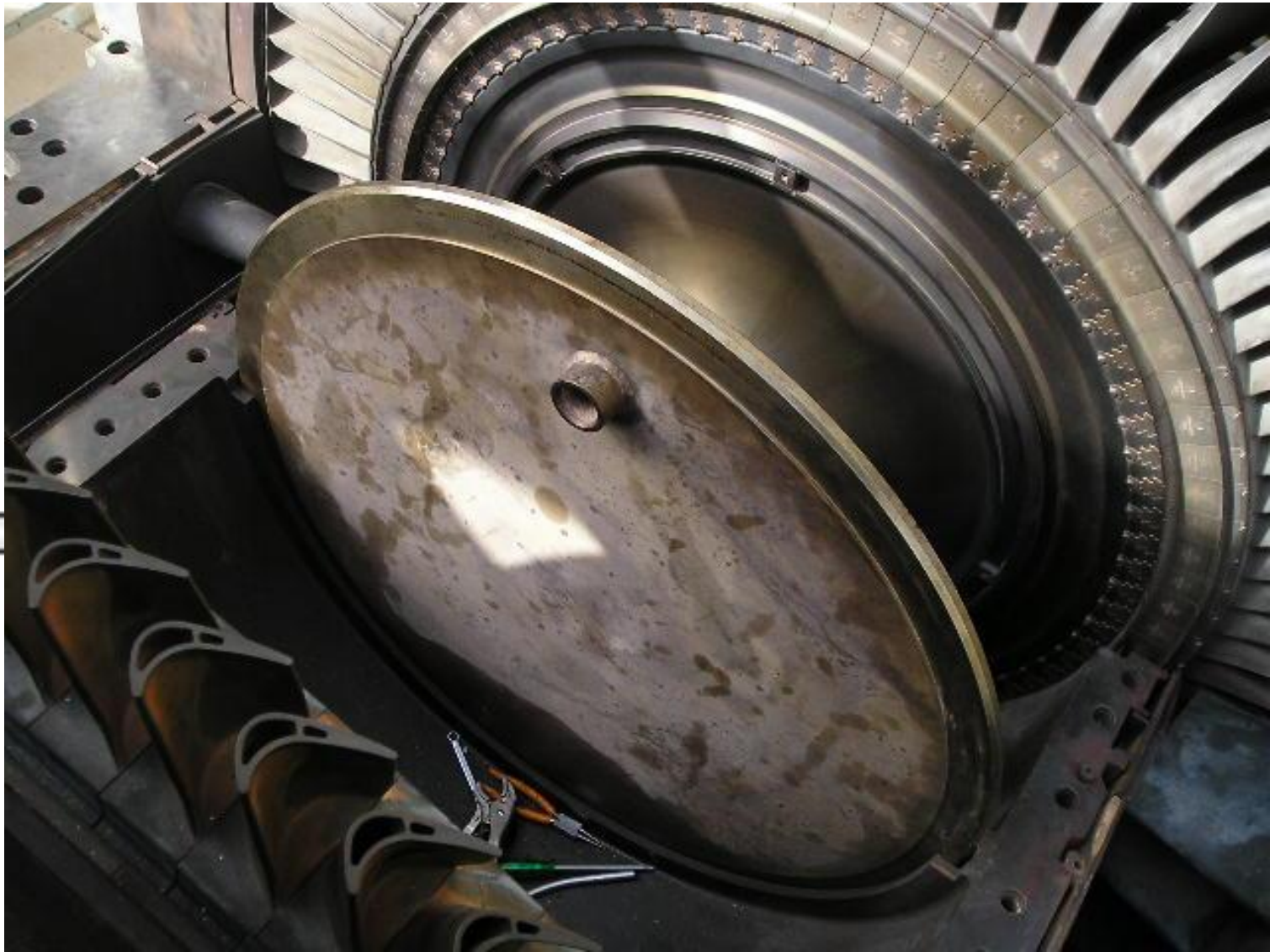

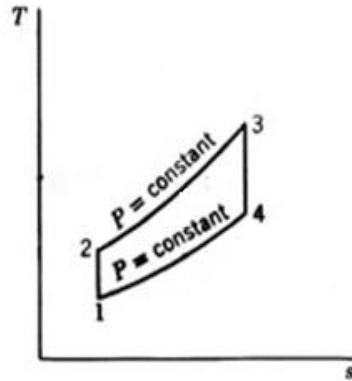
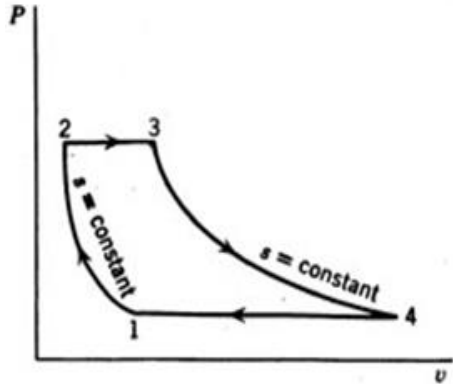

- هواکش ورودی
- کمپرسور
- اتاق احتراق
- توربین
- اگزاست

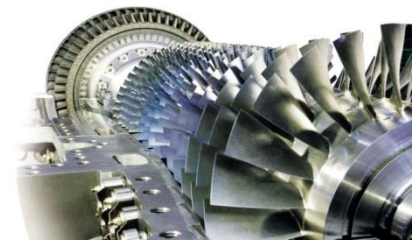
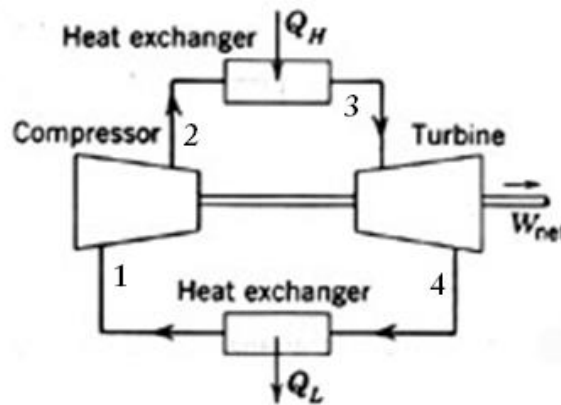
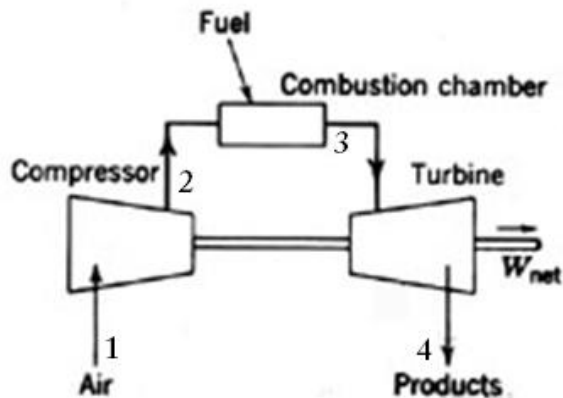

# اجزای اصلی توربین گاز

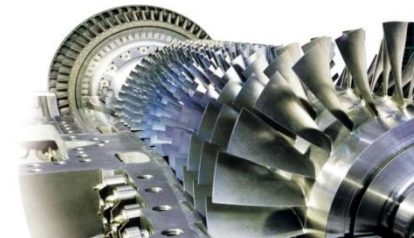
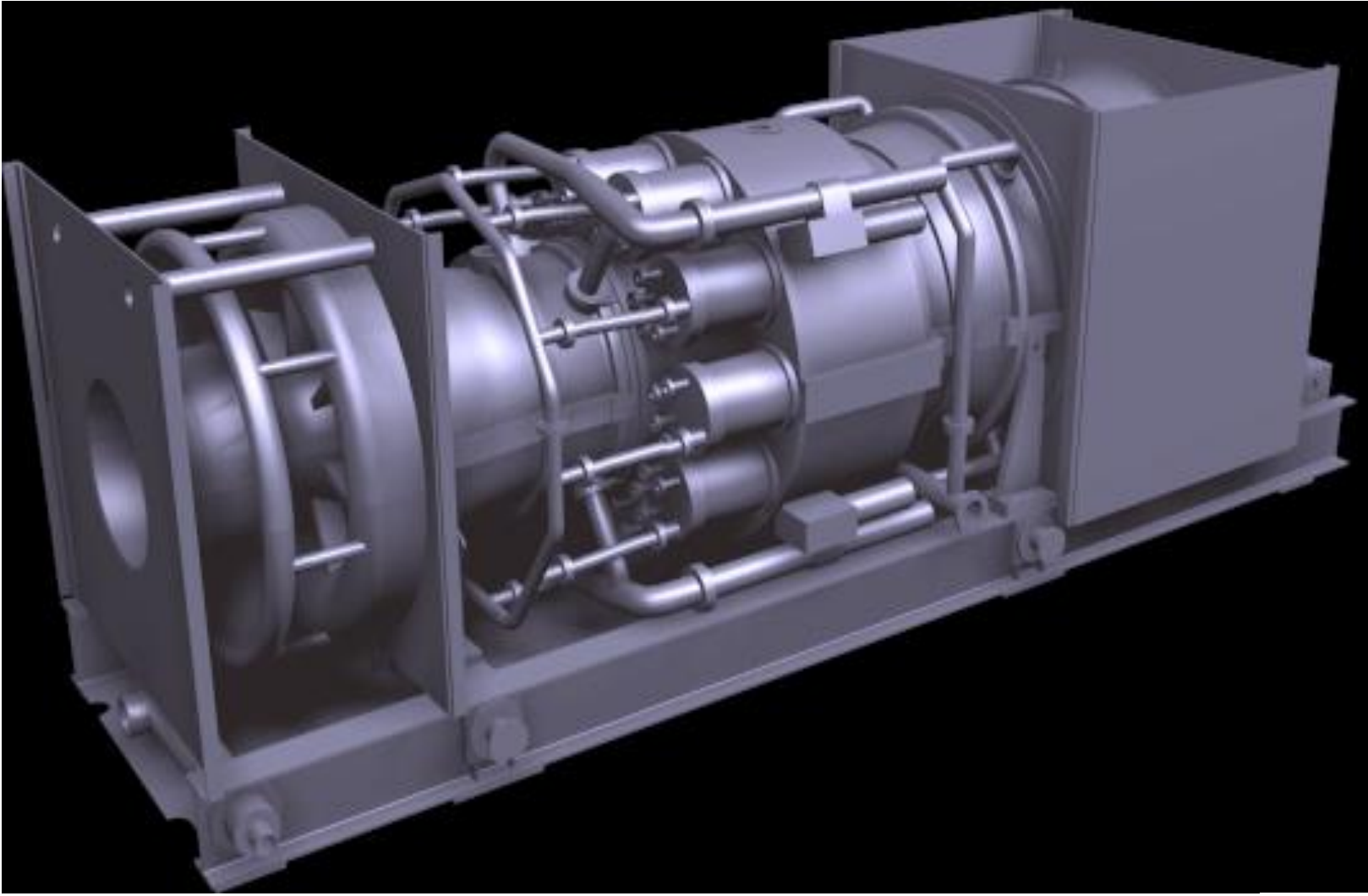

# هواکش ورودی

- فیلتر اولیه
- فیلتر ثانویه
- Silencer
- کانال ورودی
- سیستم Pulse jet

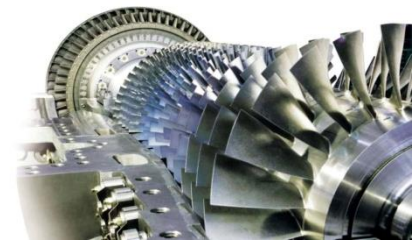
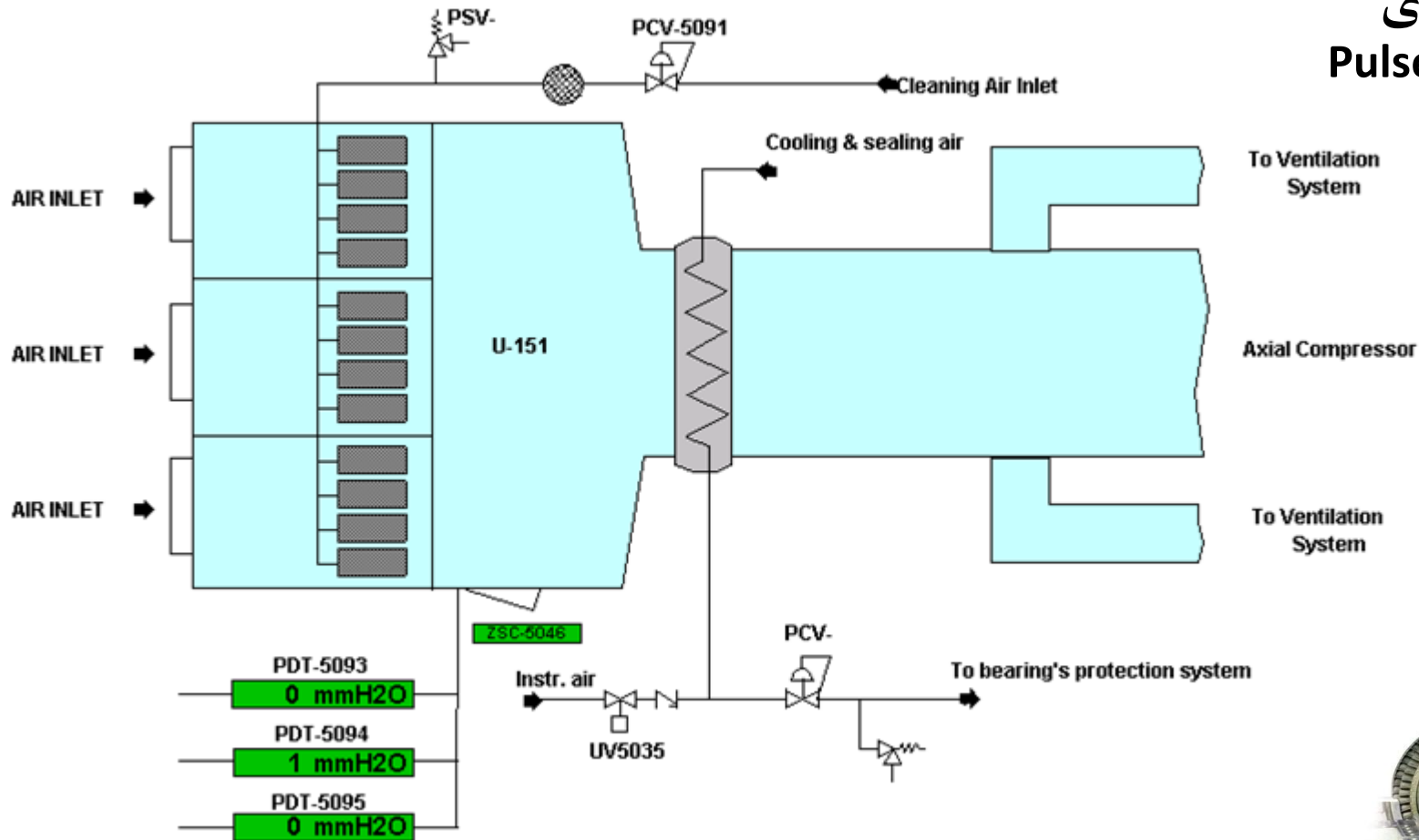





insdl.ir

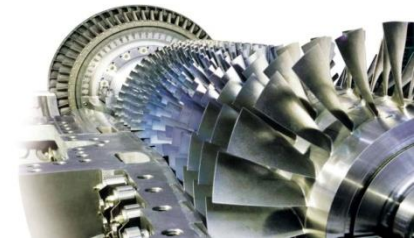



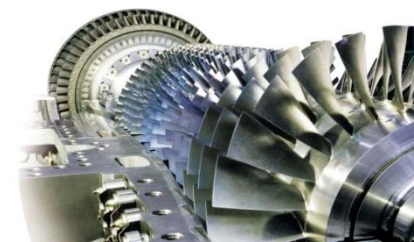
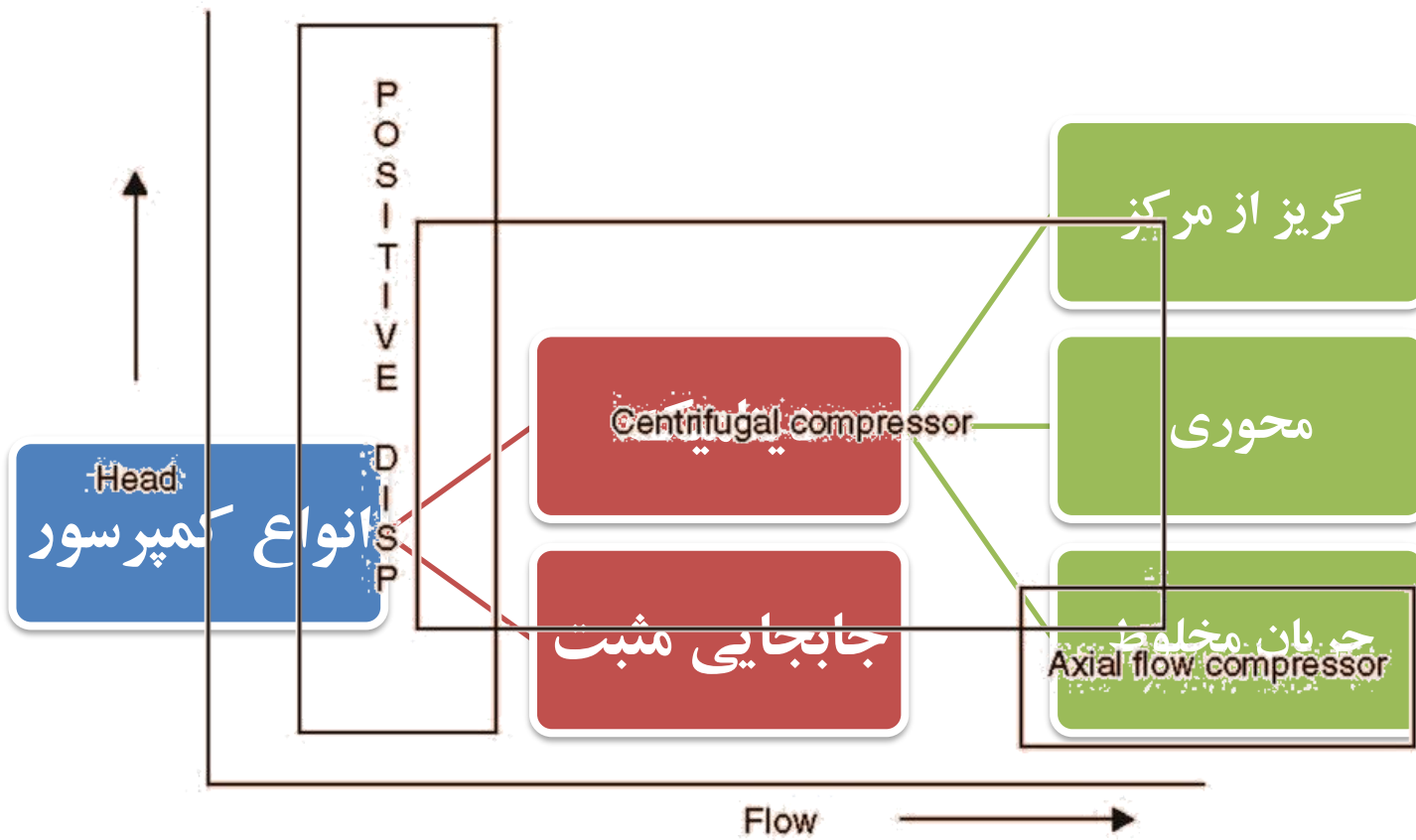

- عبور دهی جریان با دبی بالا
- راندمان آیزوانتروپیک بالا (۸۵٪)
- تعمیرات کم و نگهداری ارزان

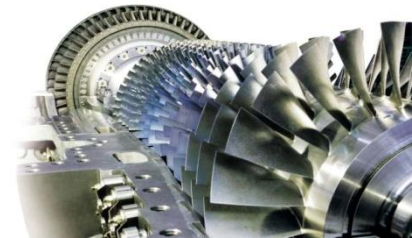

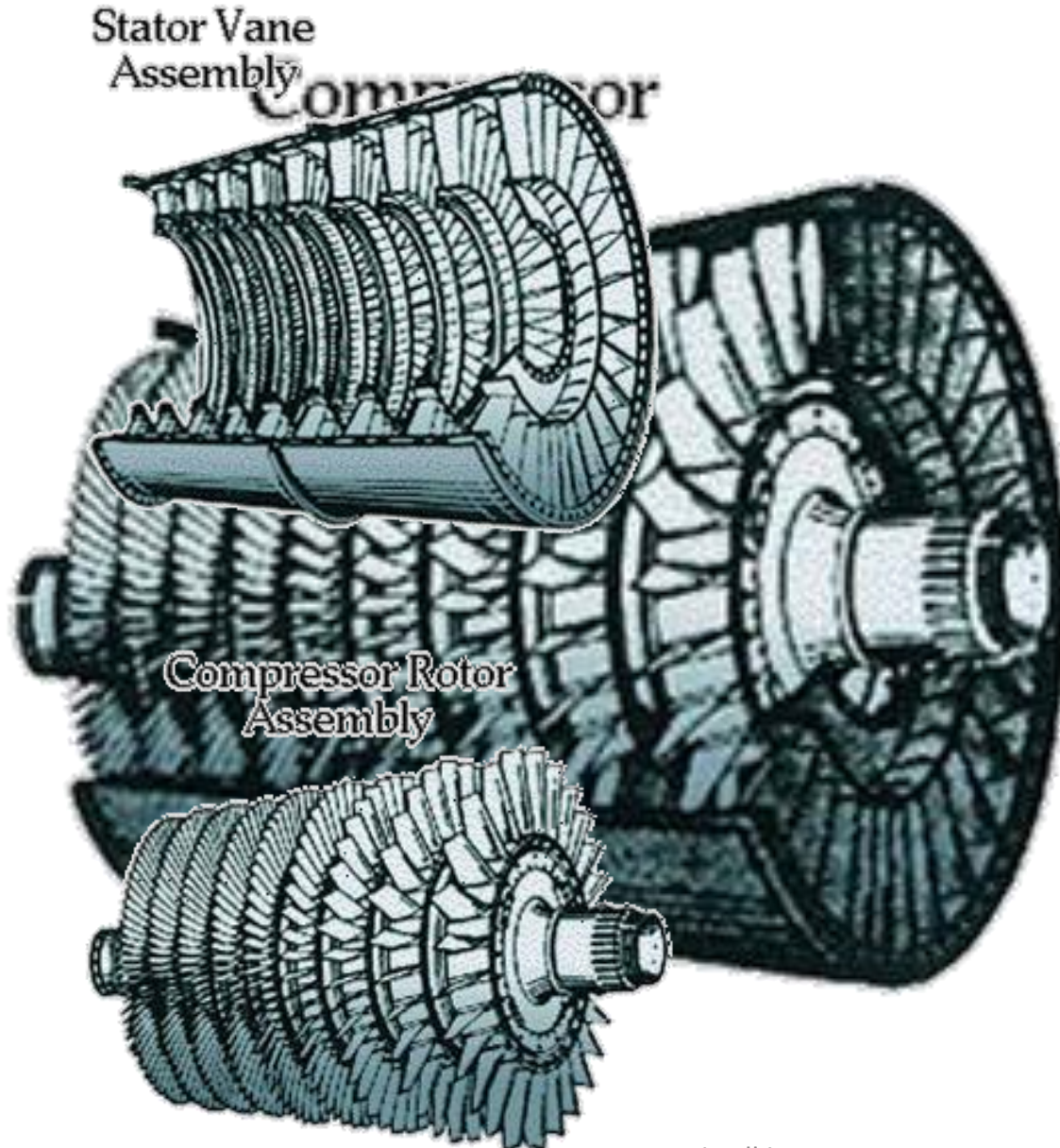

▪ پوسته (casing)

▪ قسمت ثابت (Stator)

▪ قسمت دوار (Rotor)

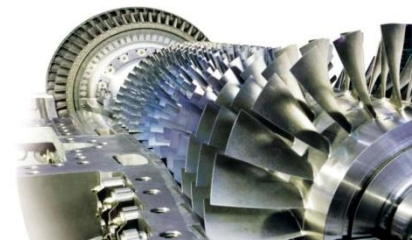



Compressor casings

Forward casing

Discharge casing

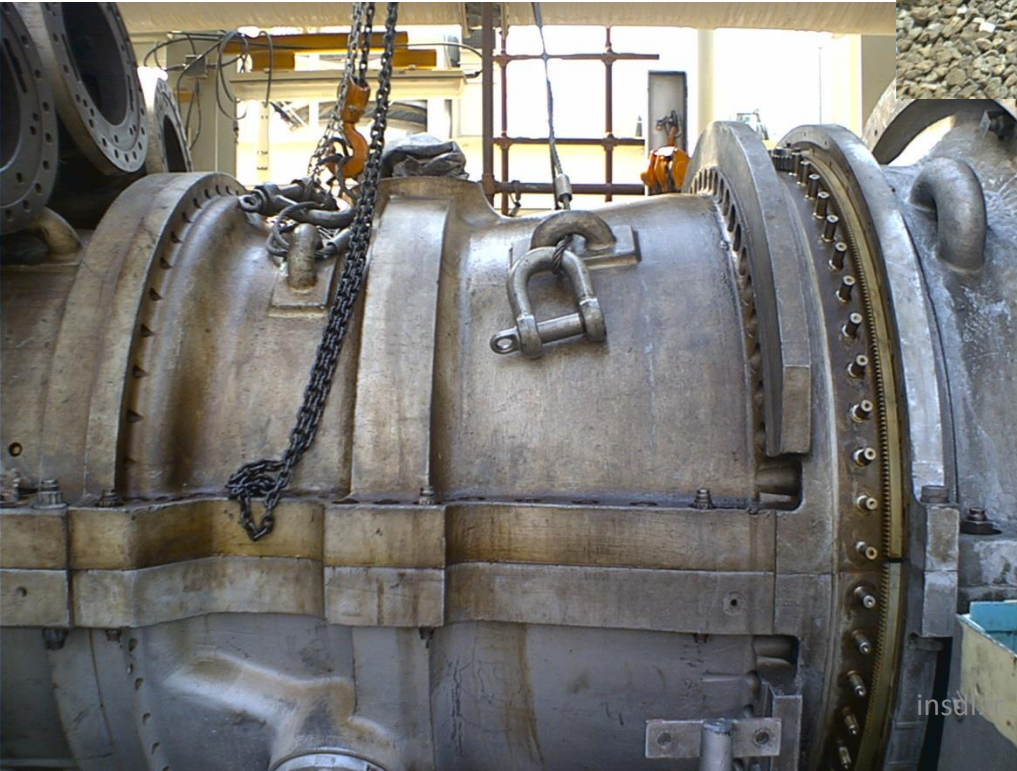

Forward casing

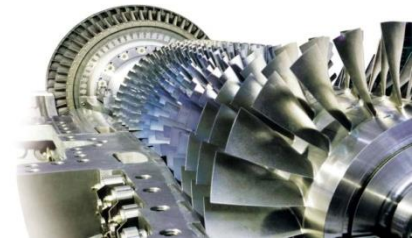



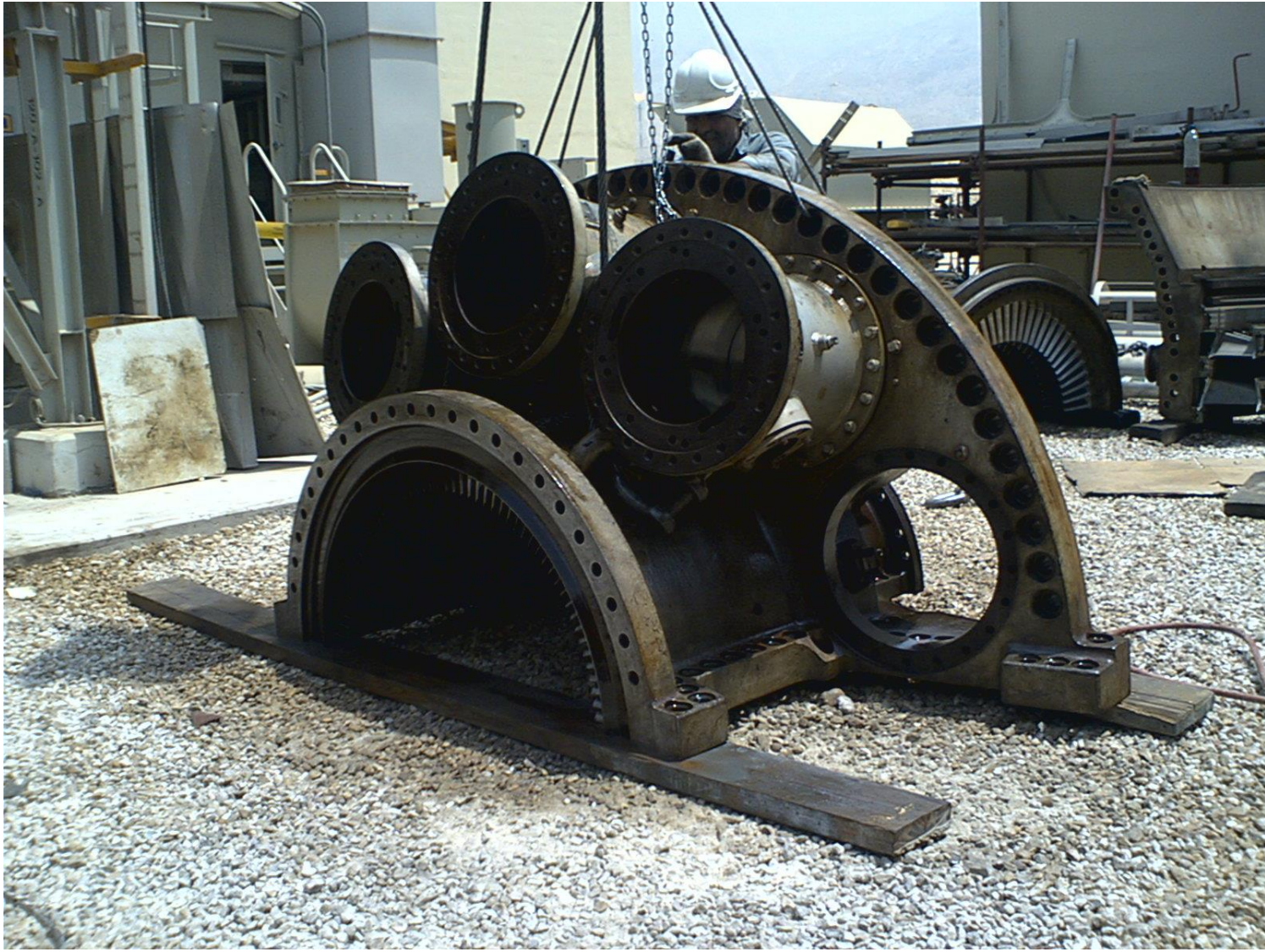

Discharge casing

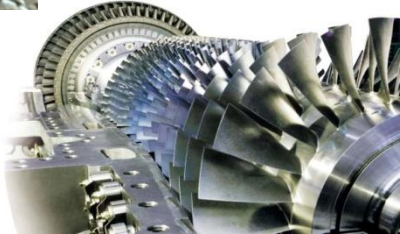



Casing without blades

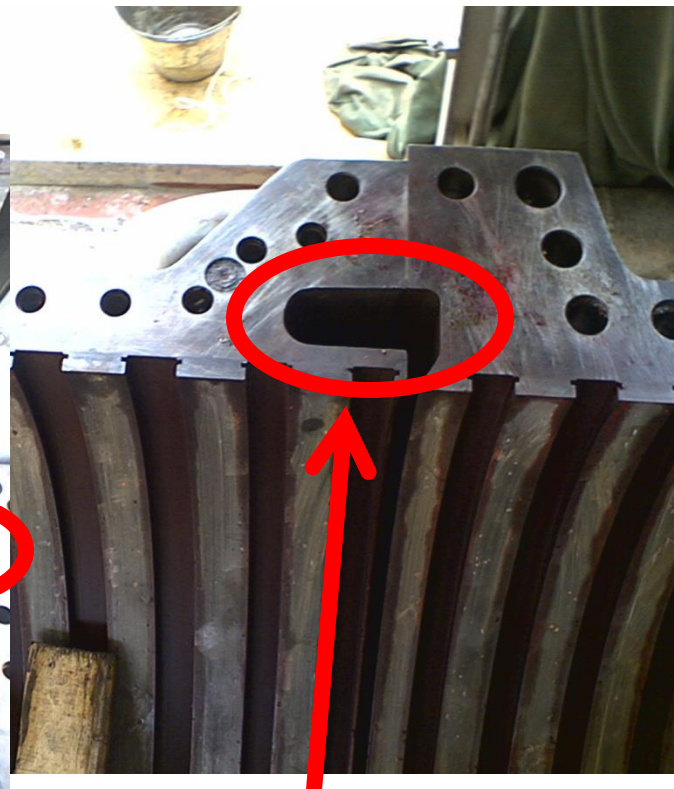
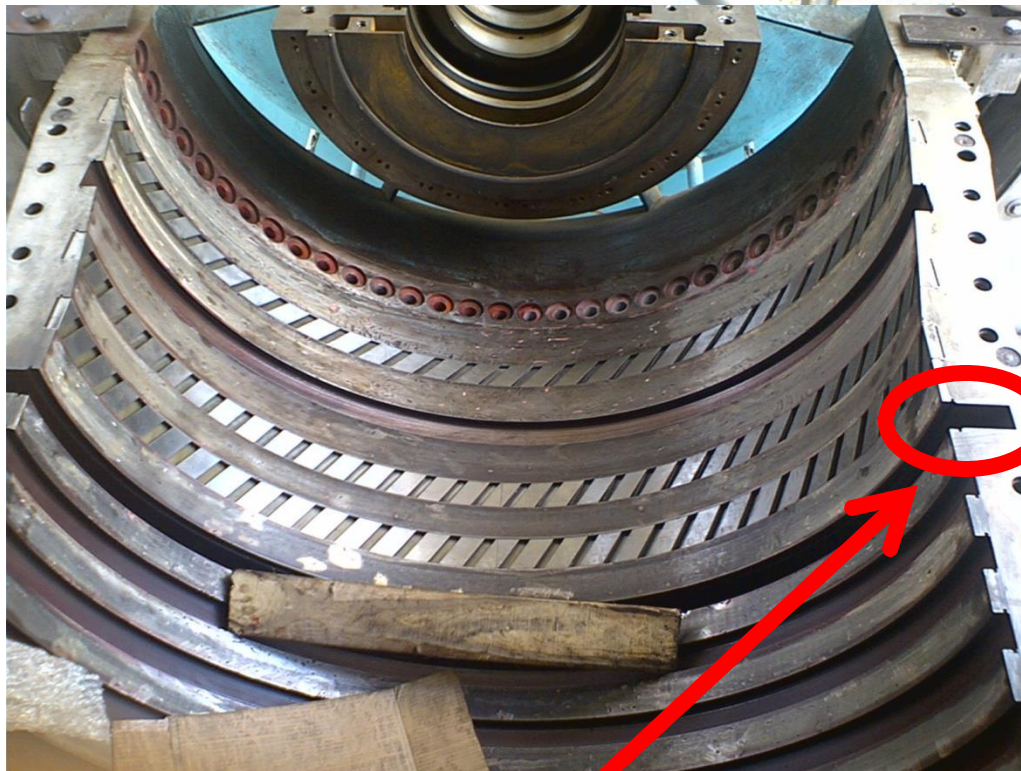

برداشت هوا برای  
خنک کاری و آب  
بندی بیرینگ

برداشت هوا برای  
جلوگیری از سرج  
(surge)

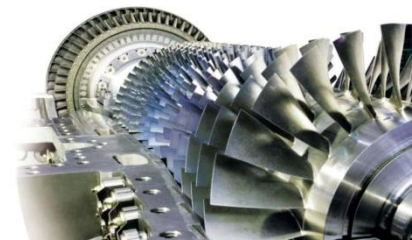





Stator blades

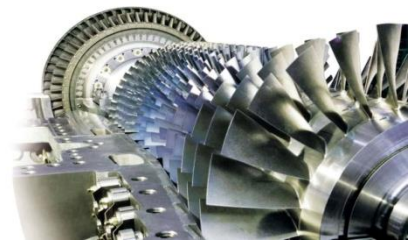

# Stator blades

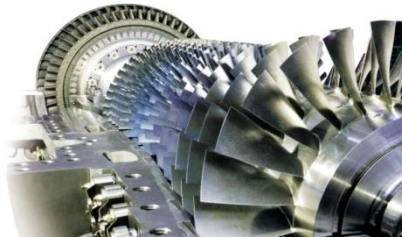
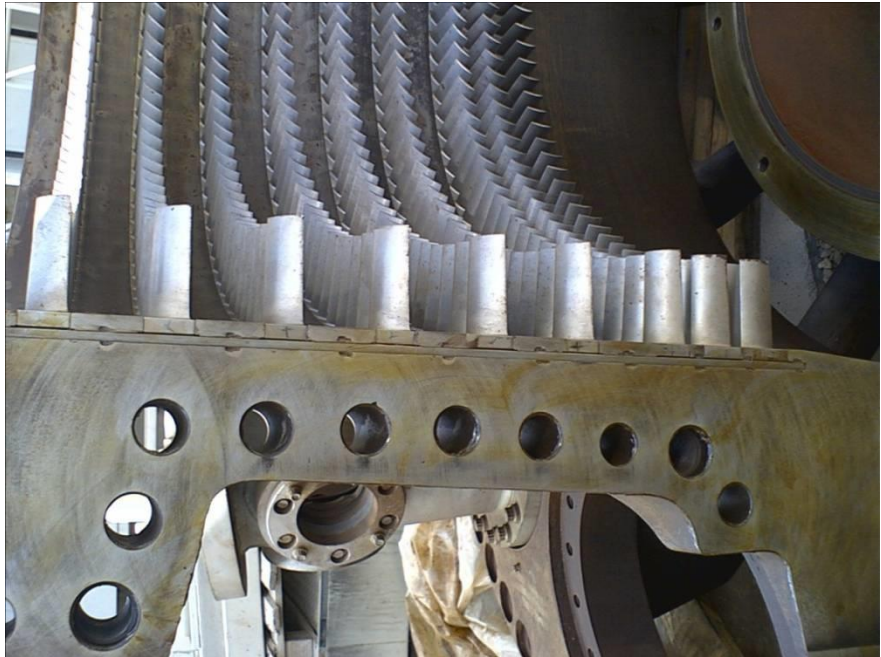



# Rotary blades Roots

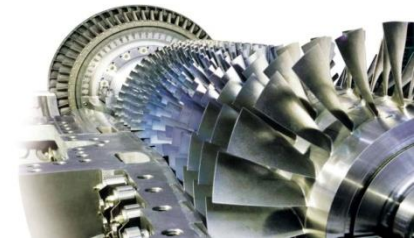
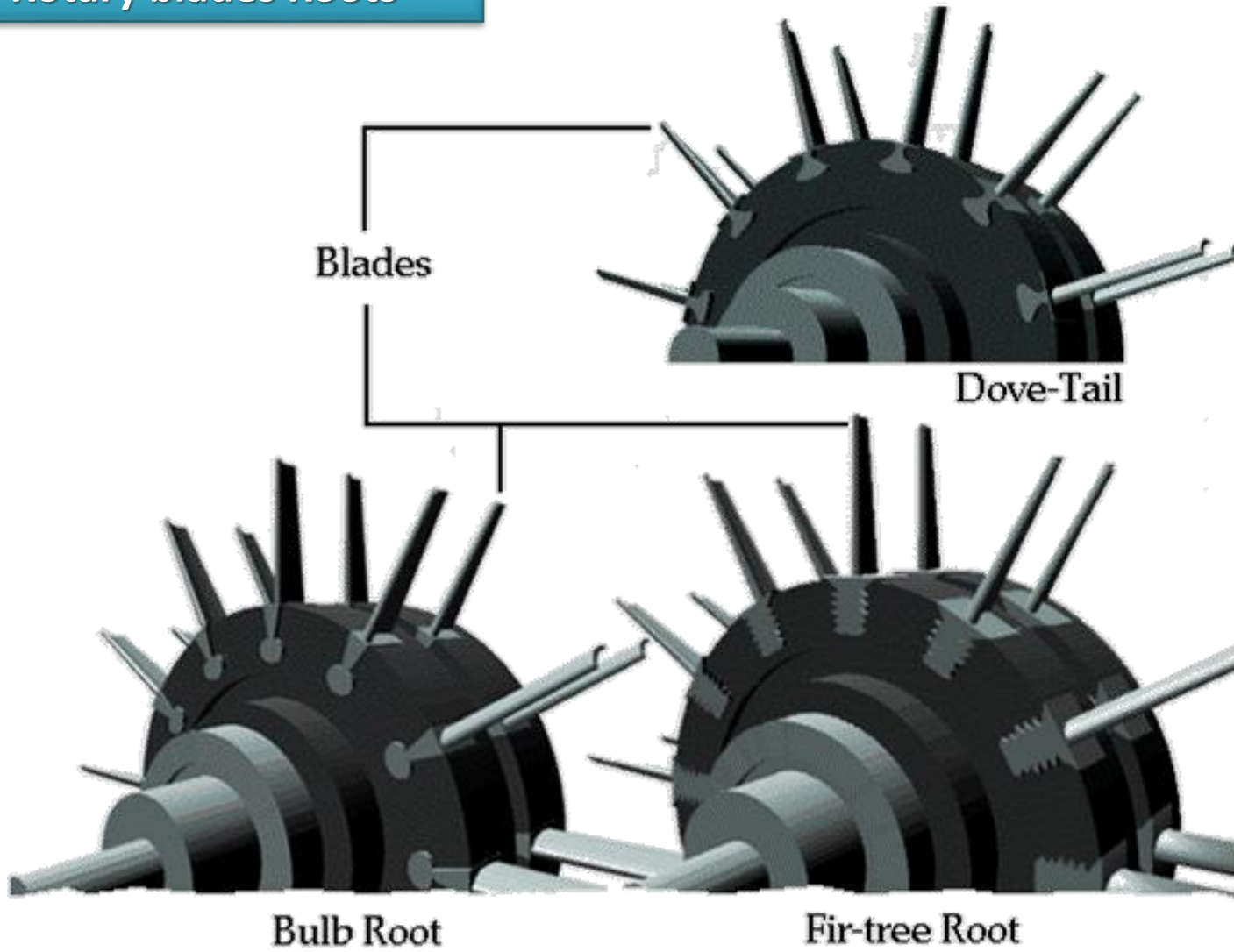

## 2 rows of Exhaust Guide Vanes

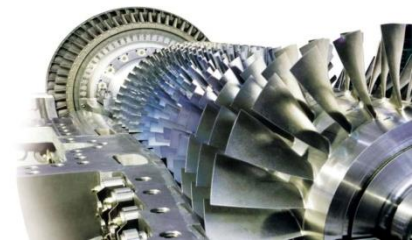
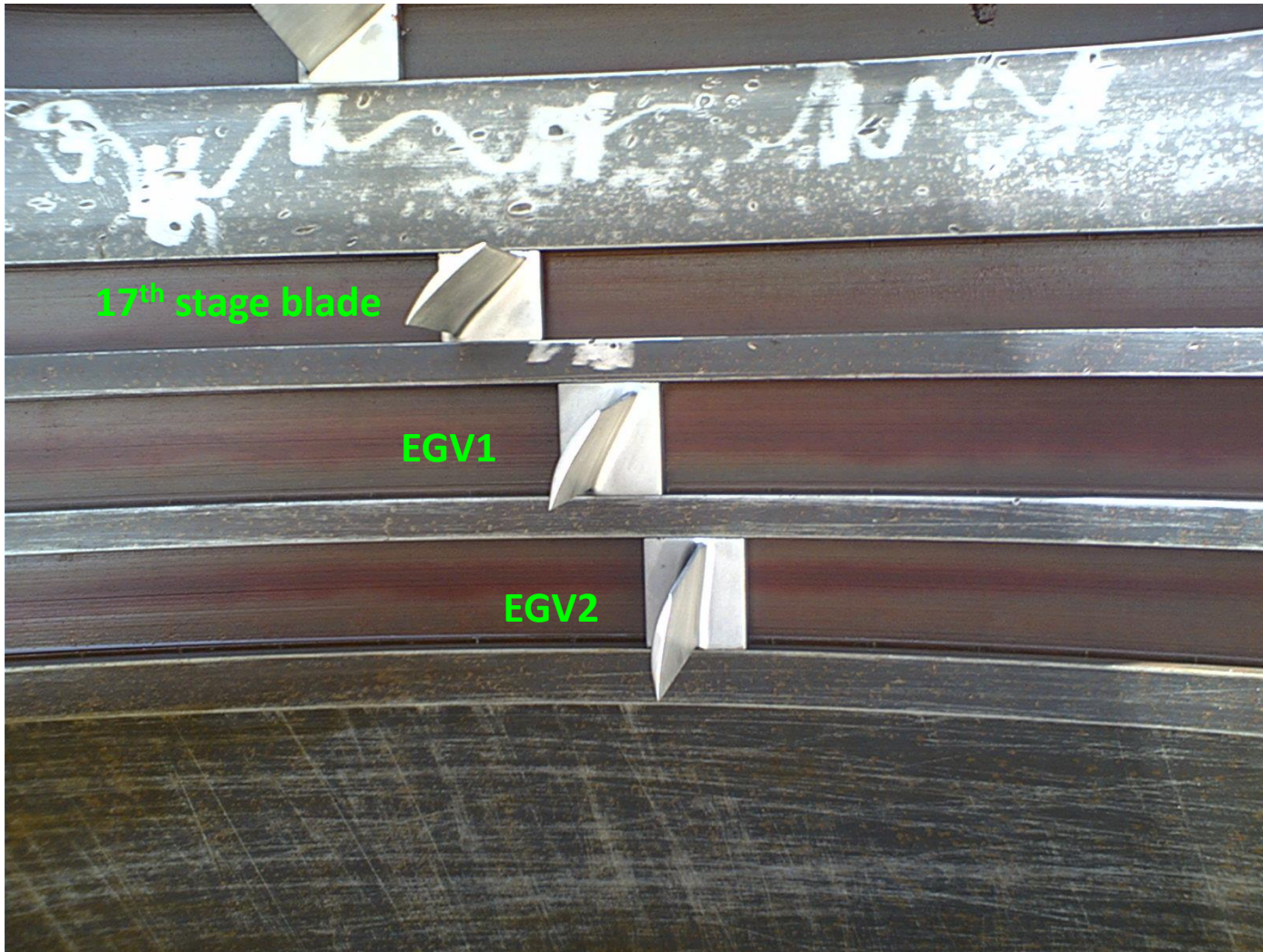



1 stage= 1 row rotary blades + 1 row stator blades



## 2 rows of Exhaust Guide Vanes





دلیل ذوزنقه ای شکل بودن پوسته کمپرسور

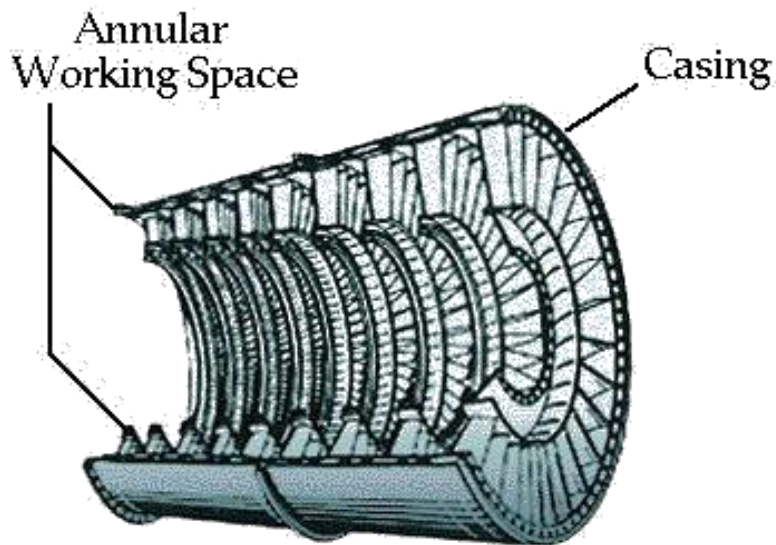
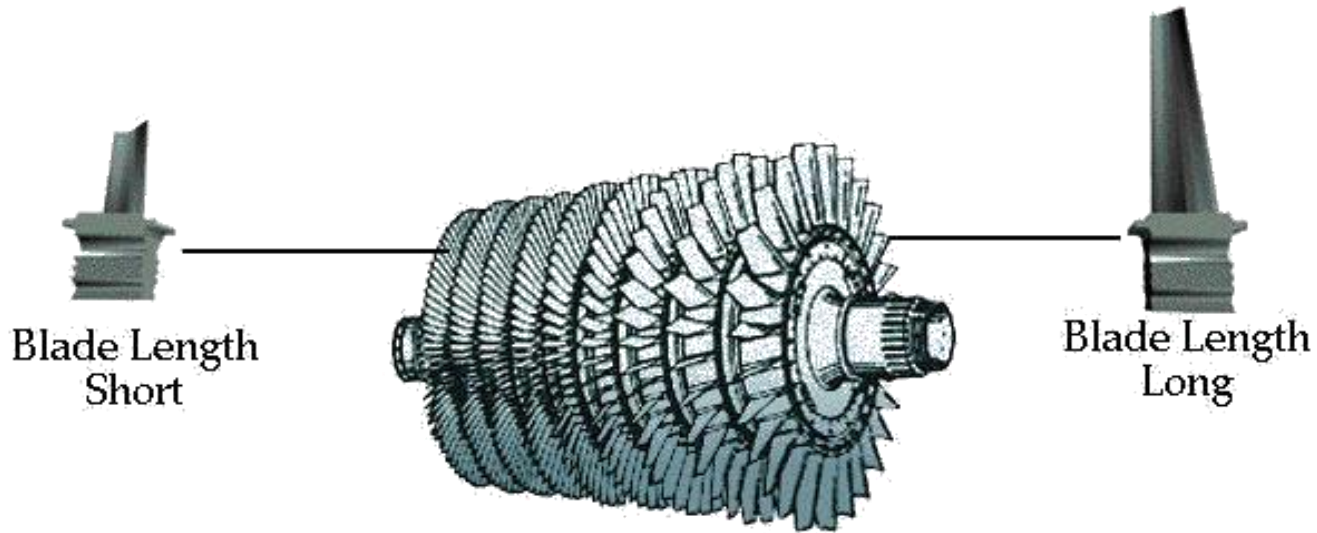

$$\dot{m} = \rho U A$$

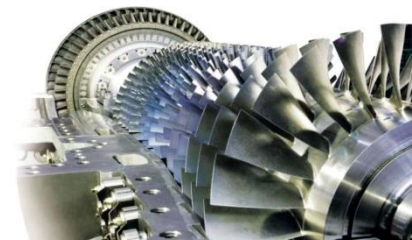

# Axial compressor of MS6001B

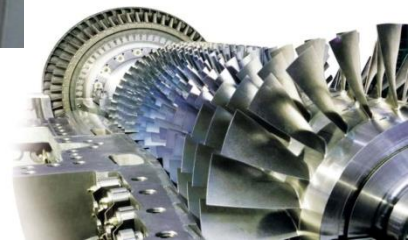
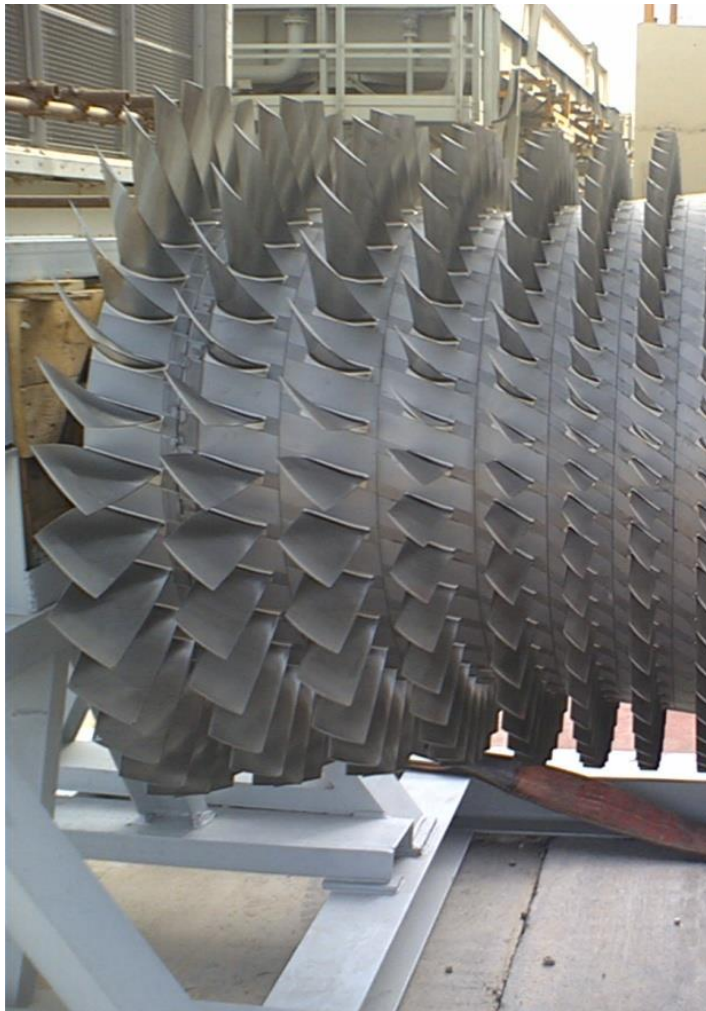



▪ کنترل دبی جرمی توربین  
▪ خنک کردن اگزاست

اجزای اصلی:

Blade▪

Gear▪

Rack▪

Rack ring▪

Actuator▪

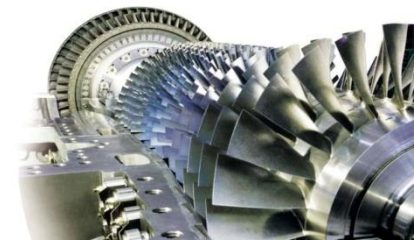

# VIGV: Variable inlet guide vane

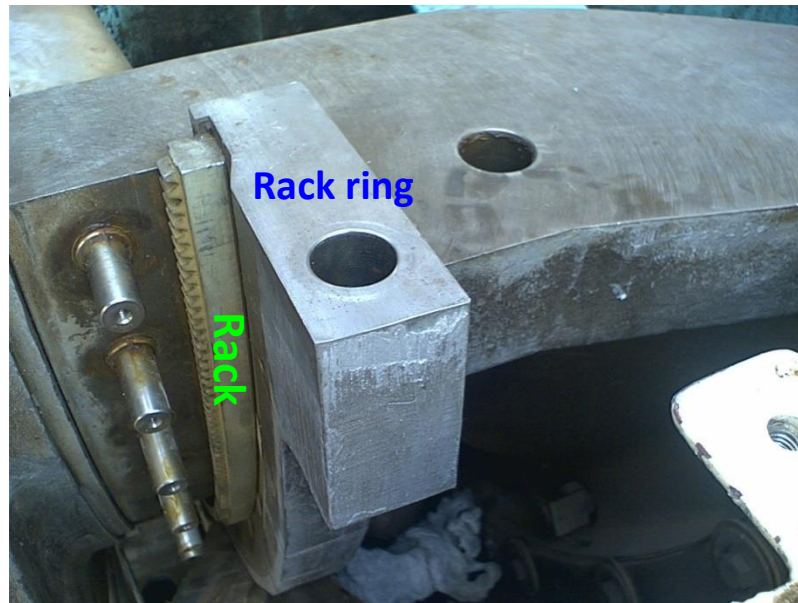
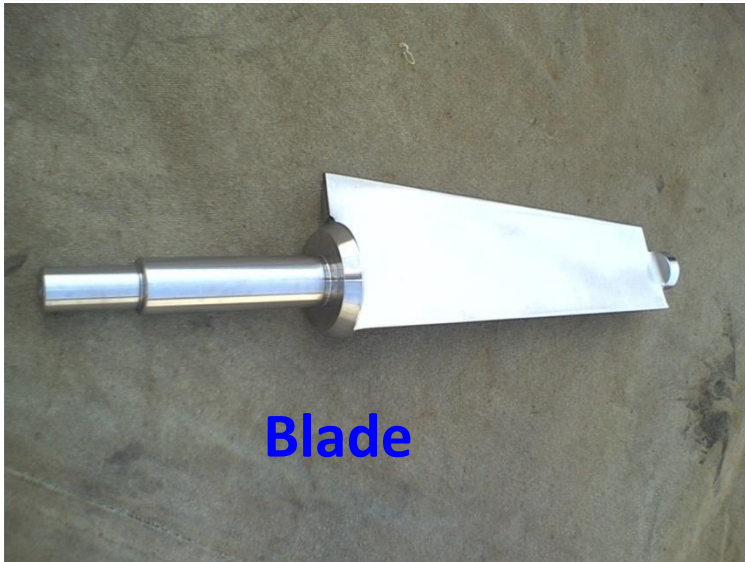

insdl.ir

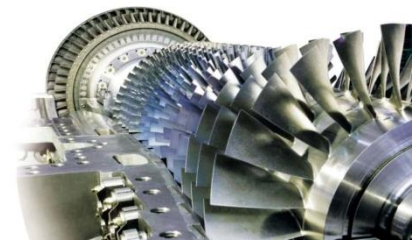



# VIGV: Variable inlet guide vane

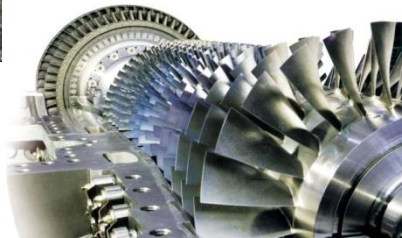
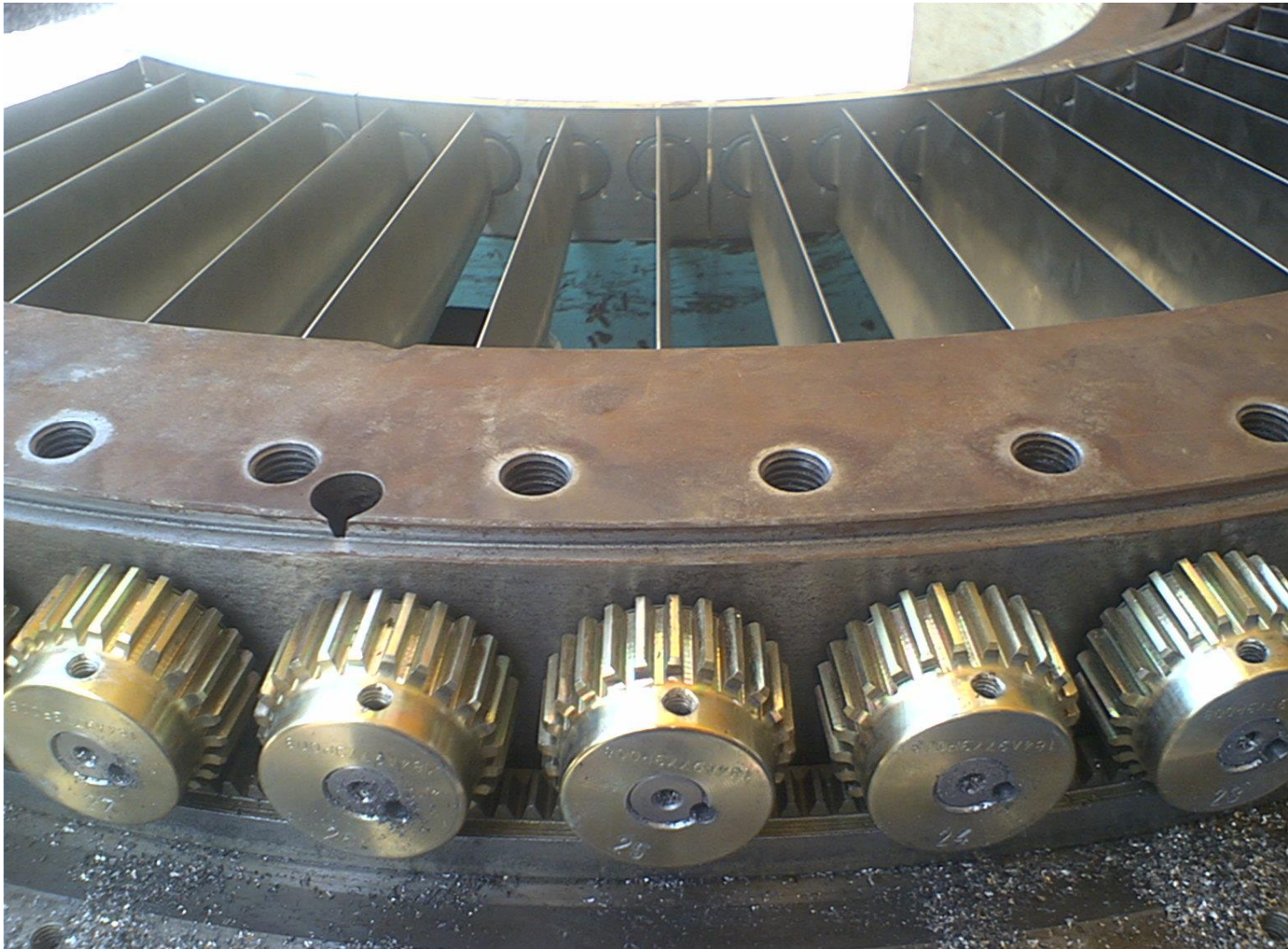



## VIGV: Variable inlet guide vane

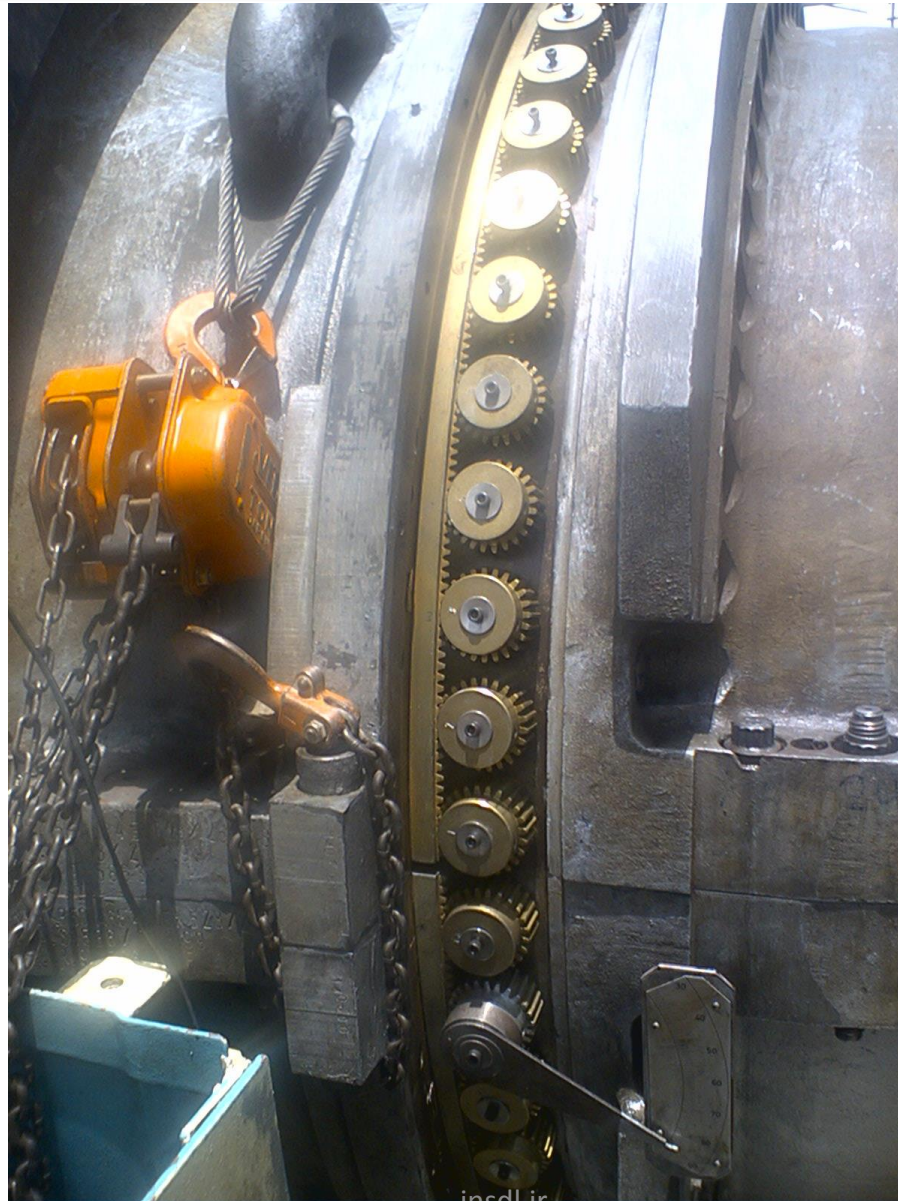

insdl.ir

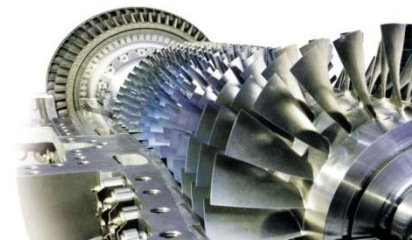

# Upper Inlet Casing

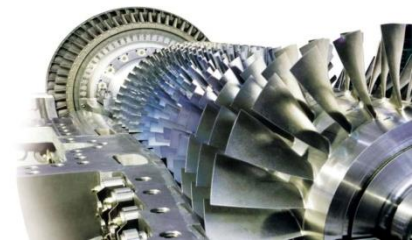



# Bleeder Valve

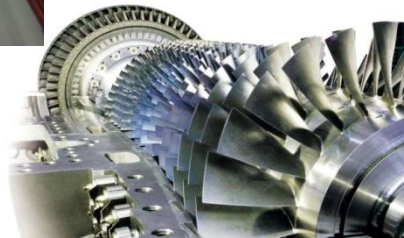



# اتاق احتراق (Combustion chamber)

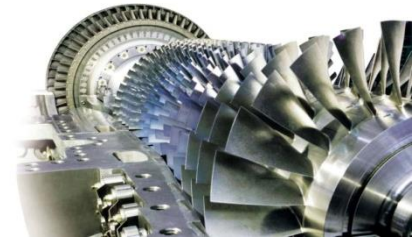
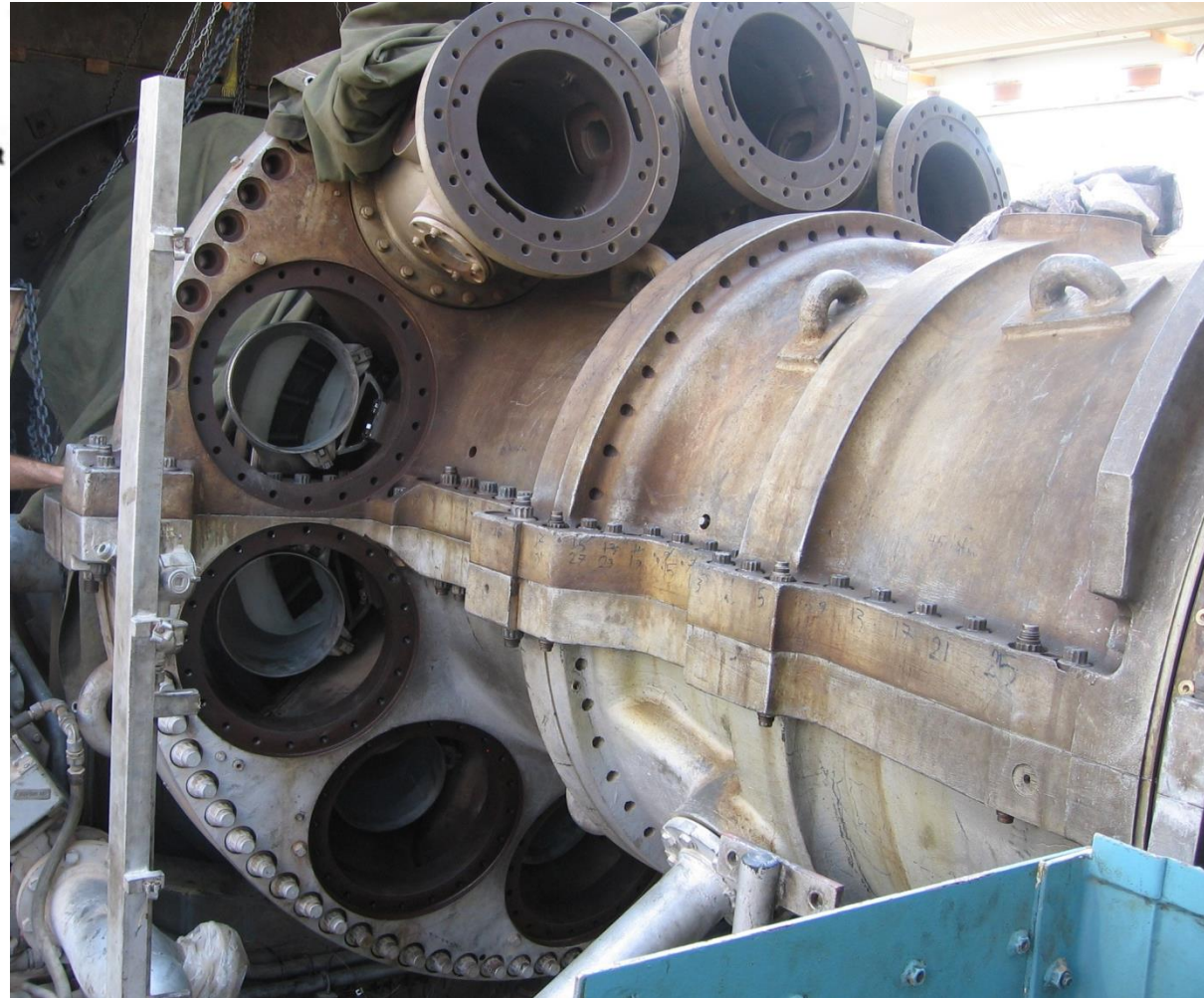
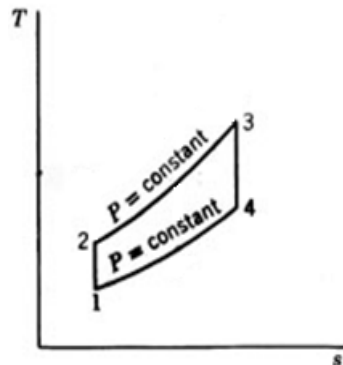
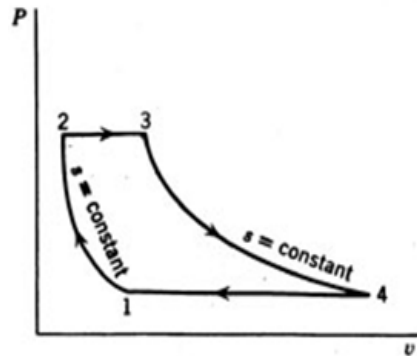
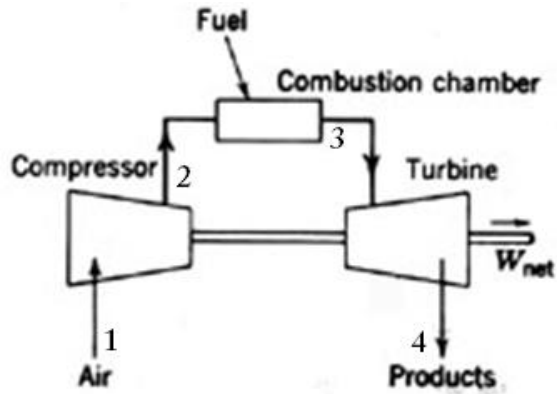

- Tubular
- Can Annular
- Annular

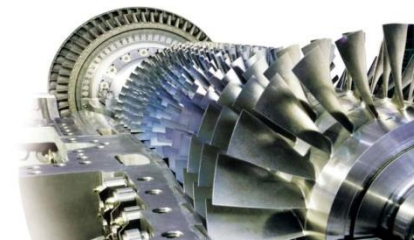
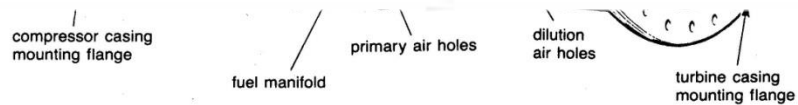
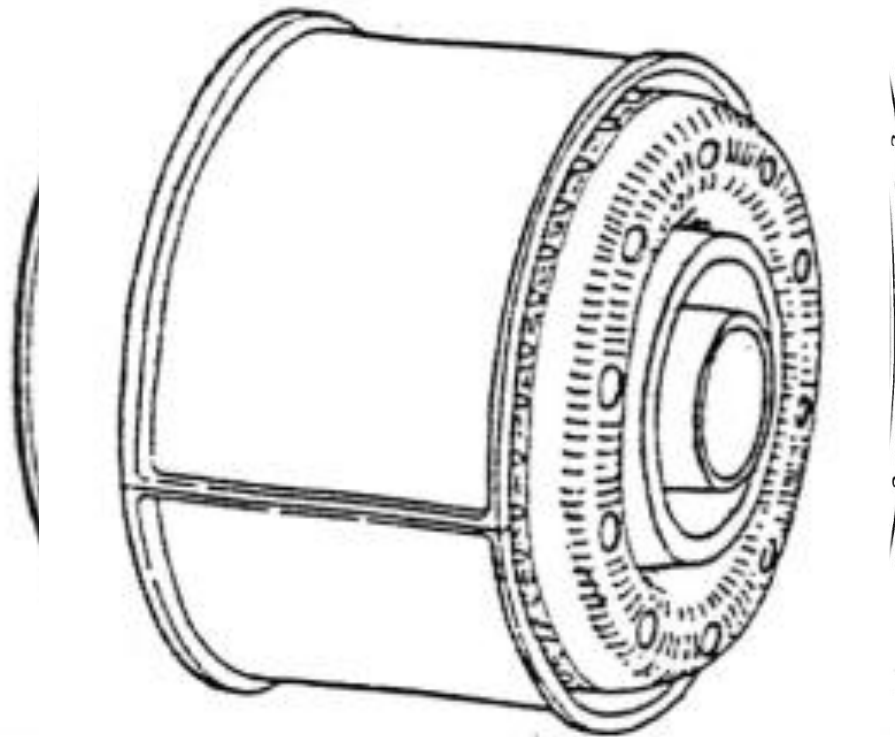
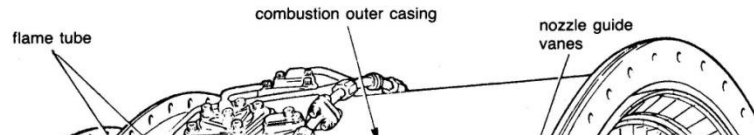

- ناحیه Recirculation
- ناحیه Burning
- ناحیه Dilution

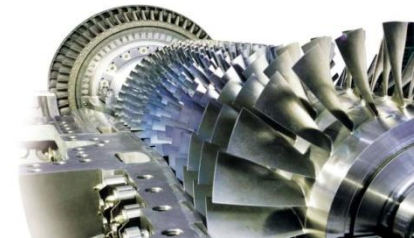
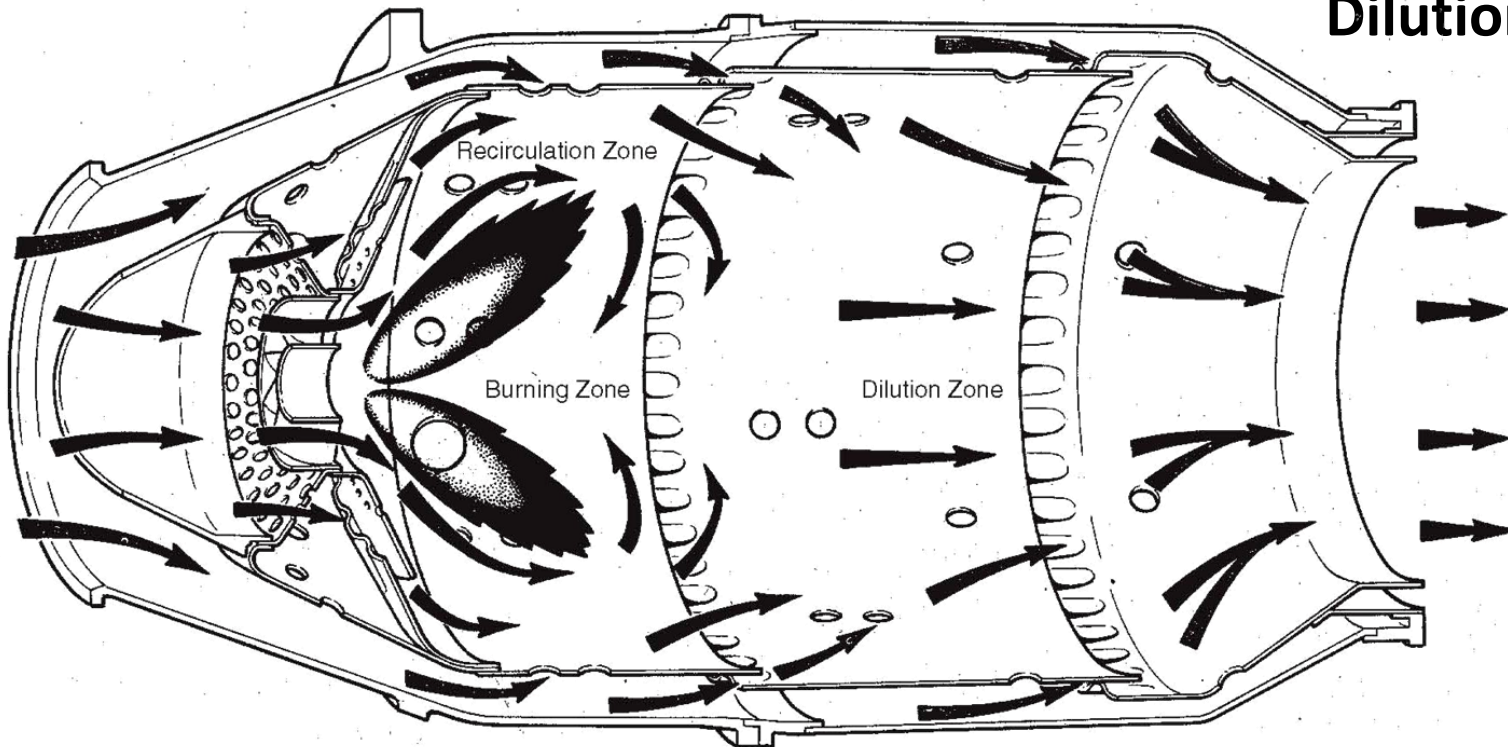



هوای اولیه 18% (Primary Air)

هوای ثانویه 82% (Secondary Air)

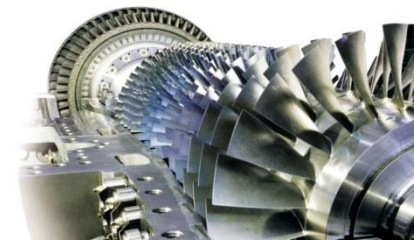
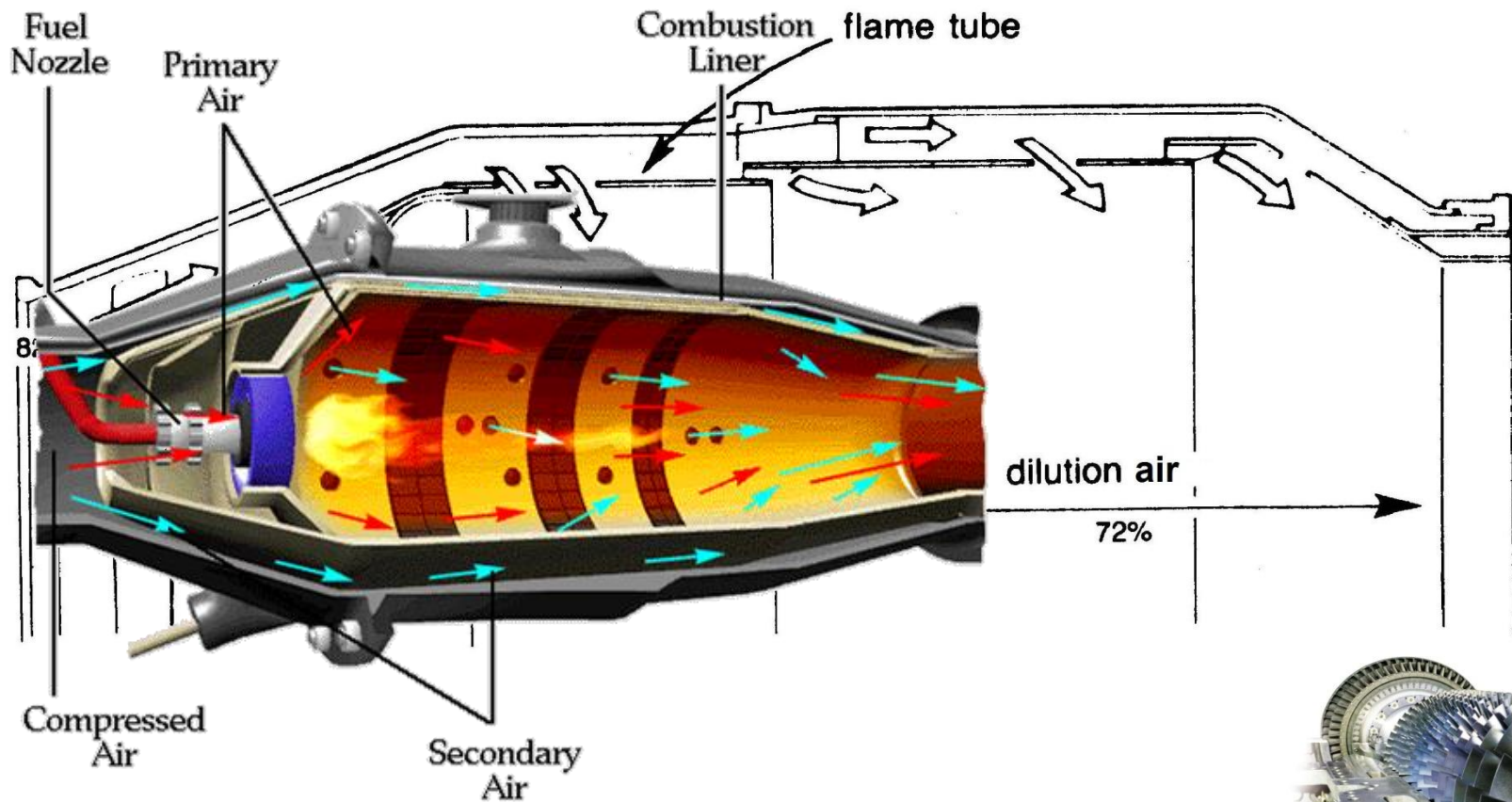

- **Fuel Nozzle** (To inject the fuel)
- **Swirl Vane** (To mix the fuel and primary air)
- **Spark Plug** (Not all of the combustors have)
- **Flame Detector** (Not all of the combustors have)
- **Flow Sleeve** (Not all of the combustors have)
- **Liner (Basket)** (To make a canal for flame)
- **Cross Fire Tube** (To transfer the flame)
- **Outer casing** (shrouds the internal components)
- **Cap** (Covers the forward end)

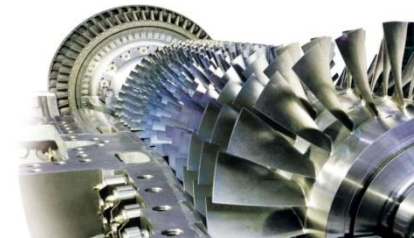
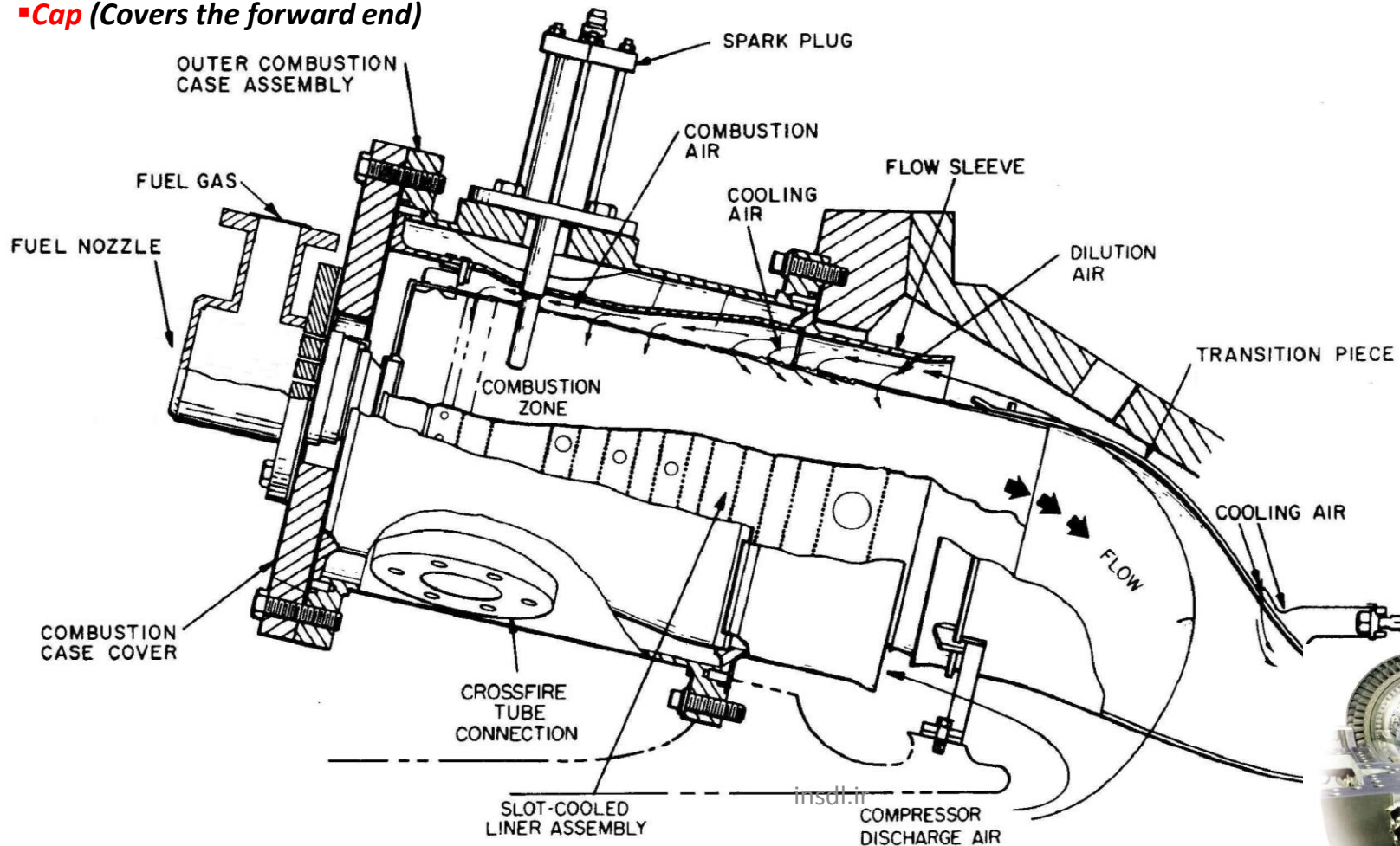



# Fuel Nozzle (نازل سوخت)

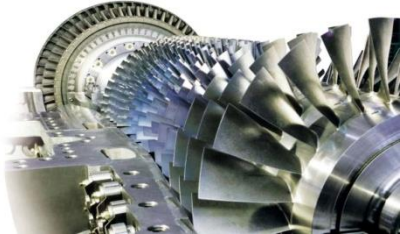
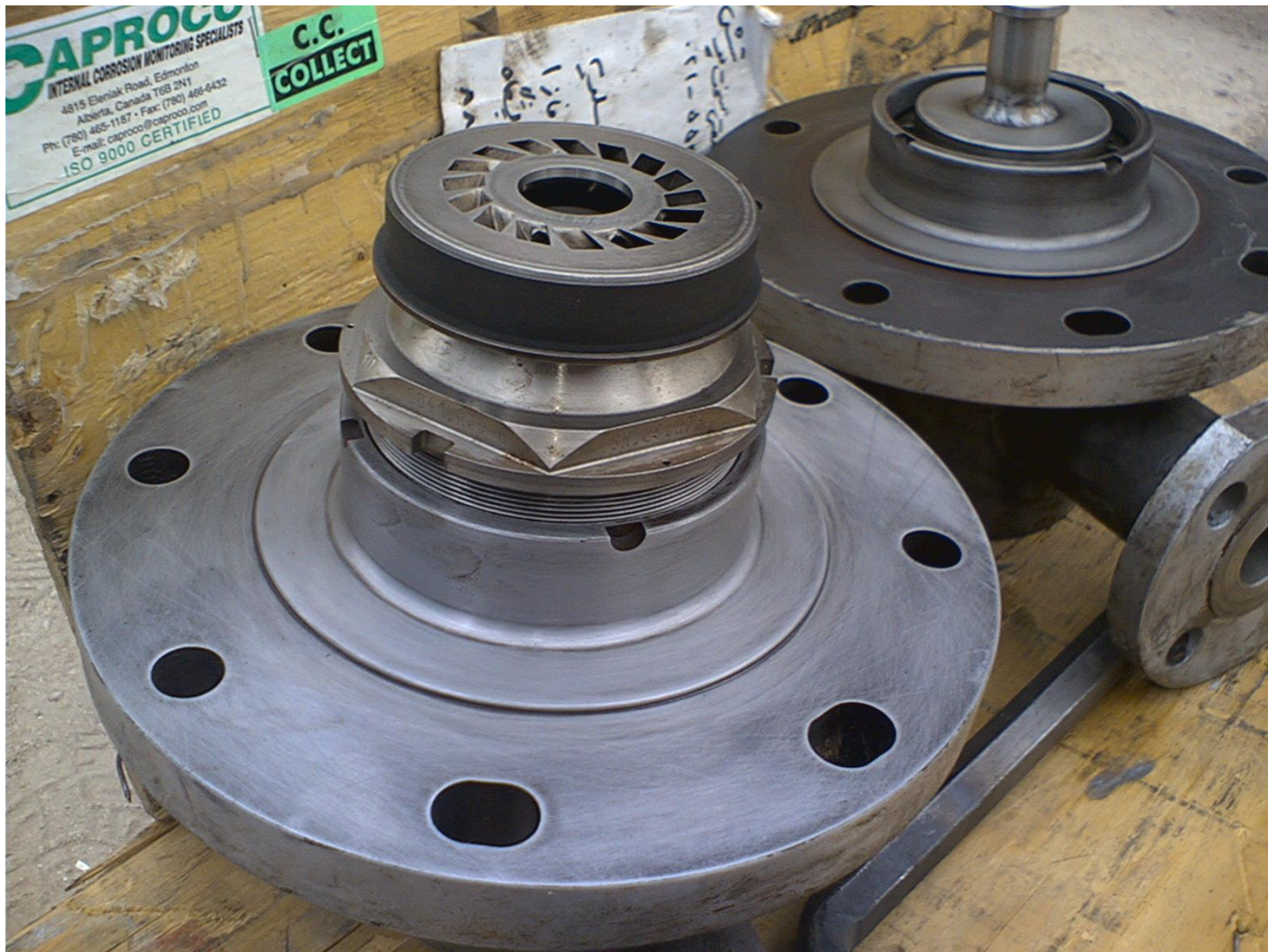



# Fuel Nozzle Assembly



Swirl Vane  
(پره پیچشی)

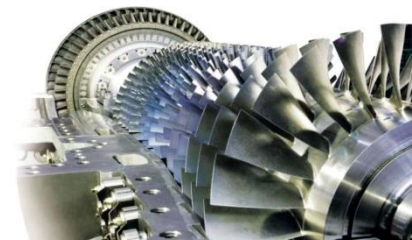



شمع جرقه (Spark plug)

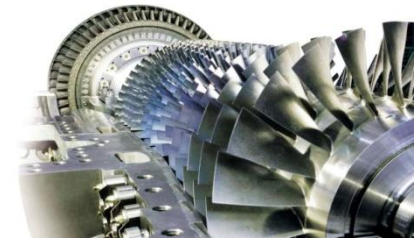
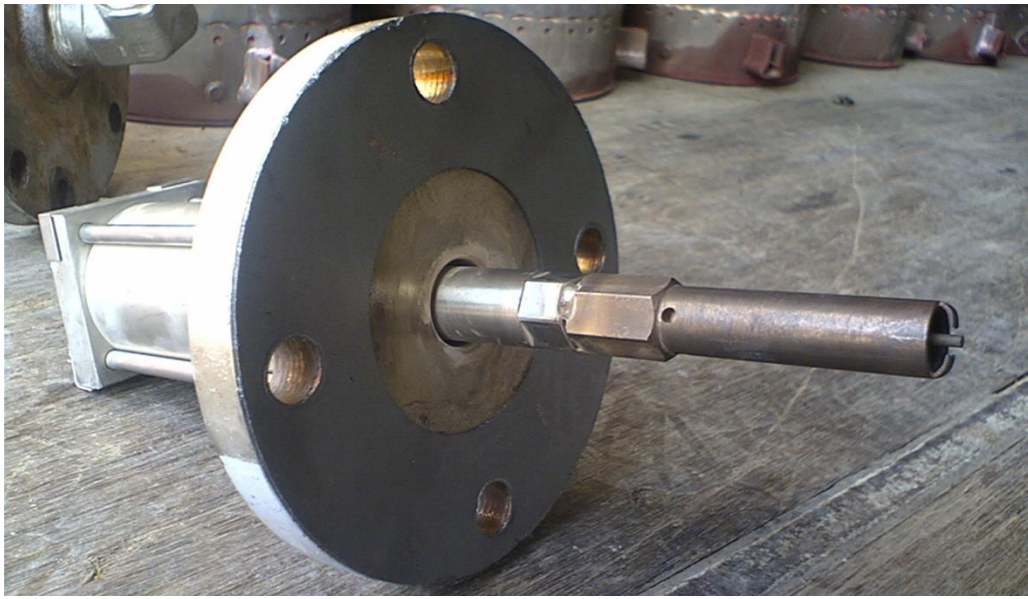



Flame detector (شعله پا)



## Flow sleeve



Cooling holes

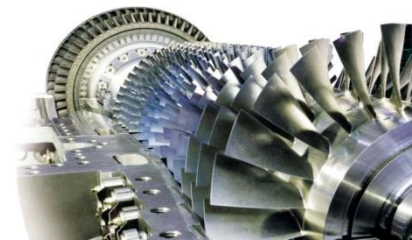



# Flow sleeve

The liner stoppers

The retainers slots

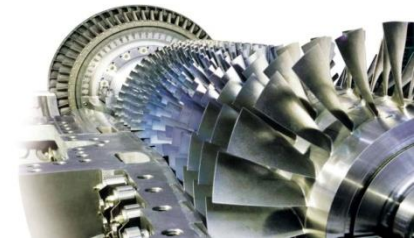
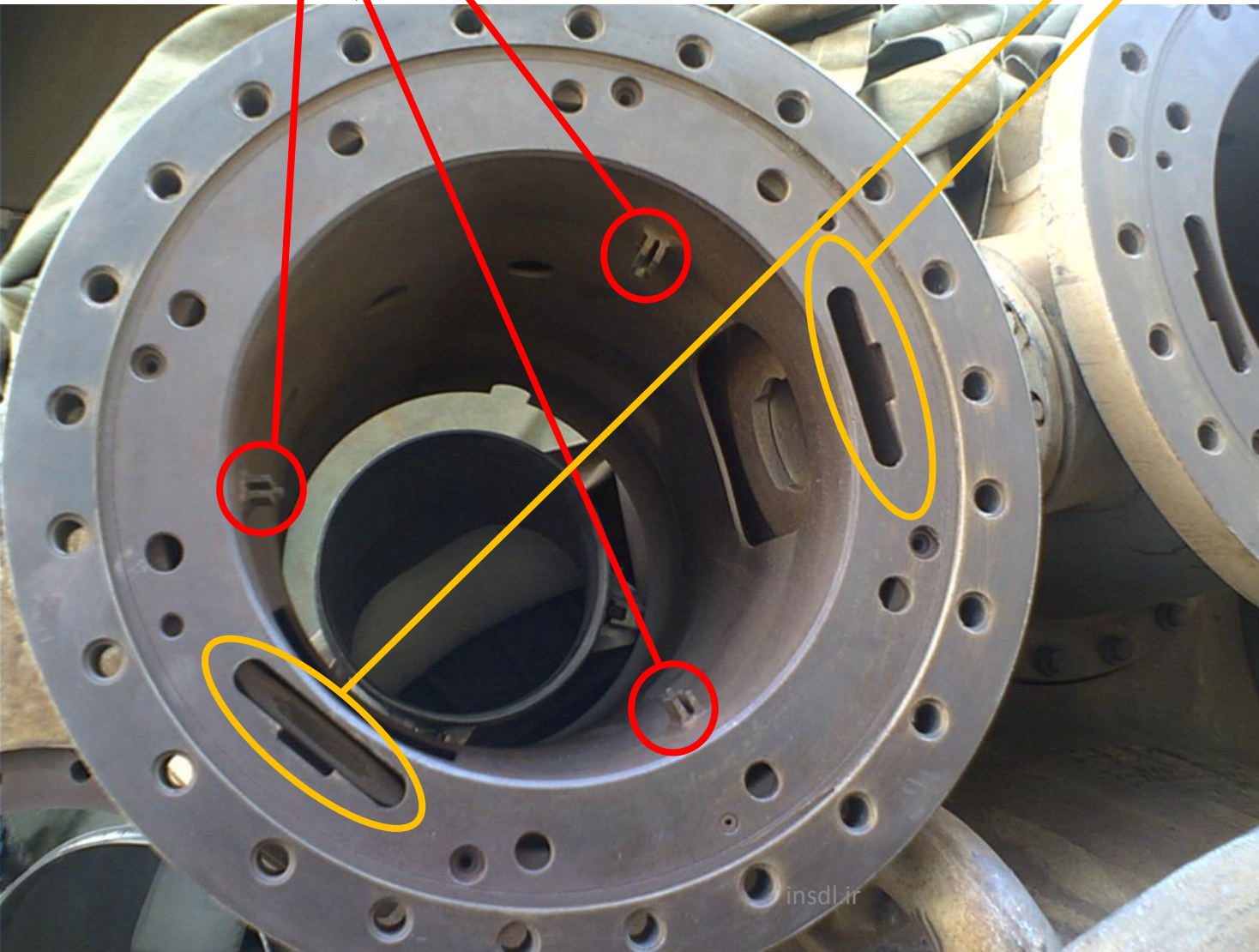

Liner

Cross fire tubes holes

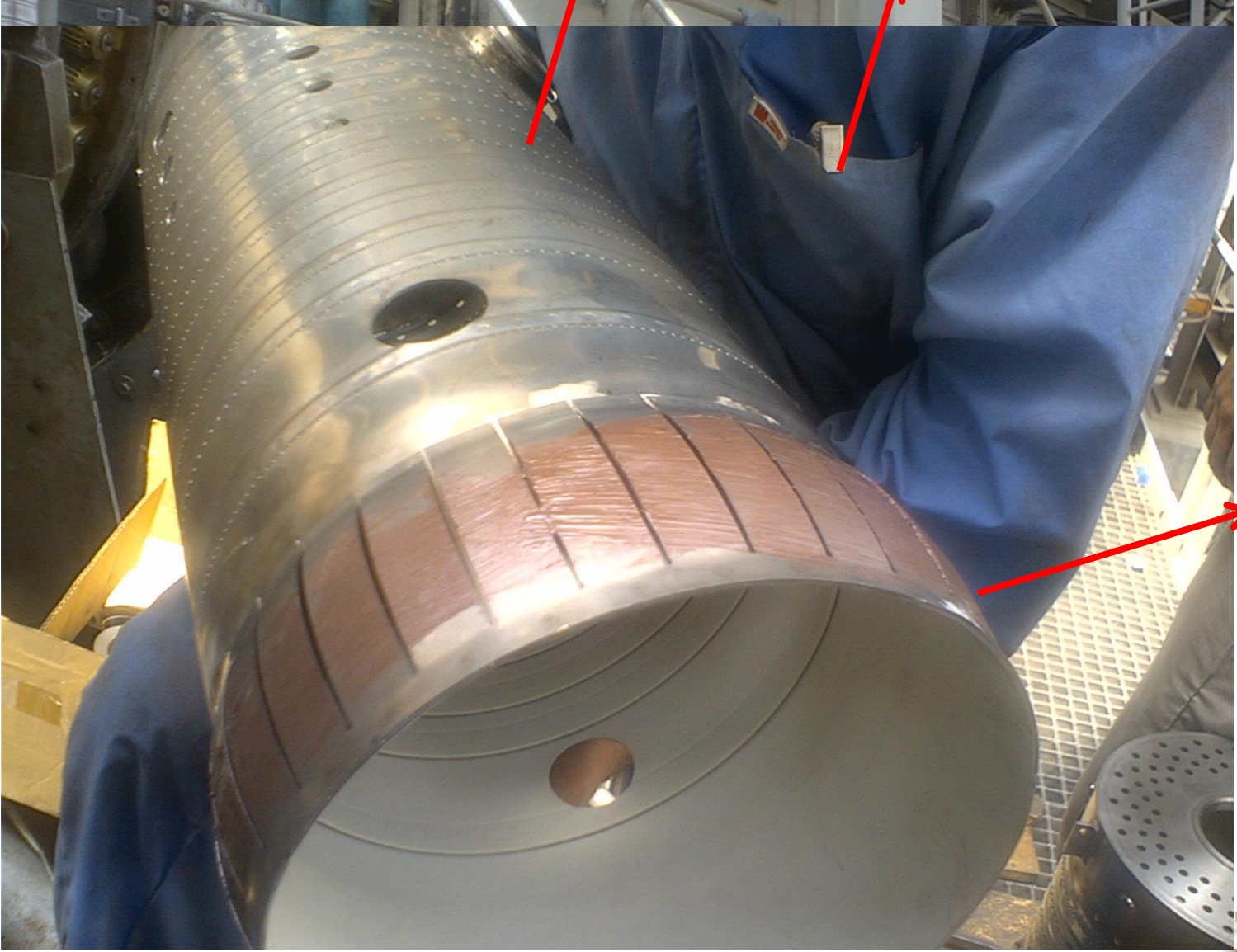

Flexible Spring

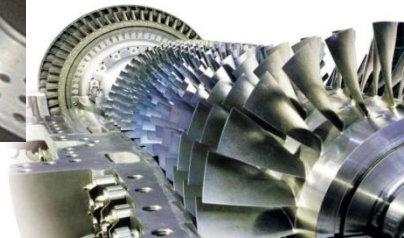



Liner (forward end view)

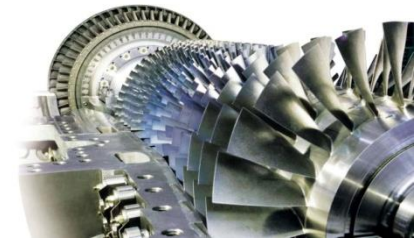
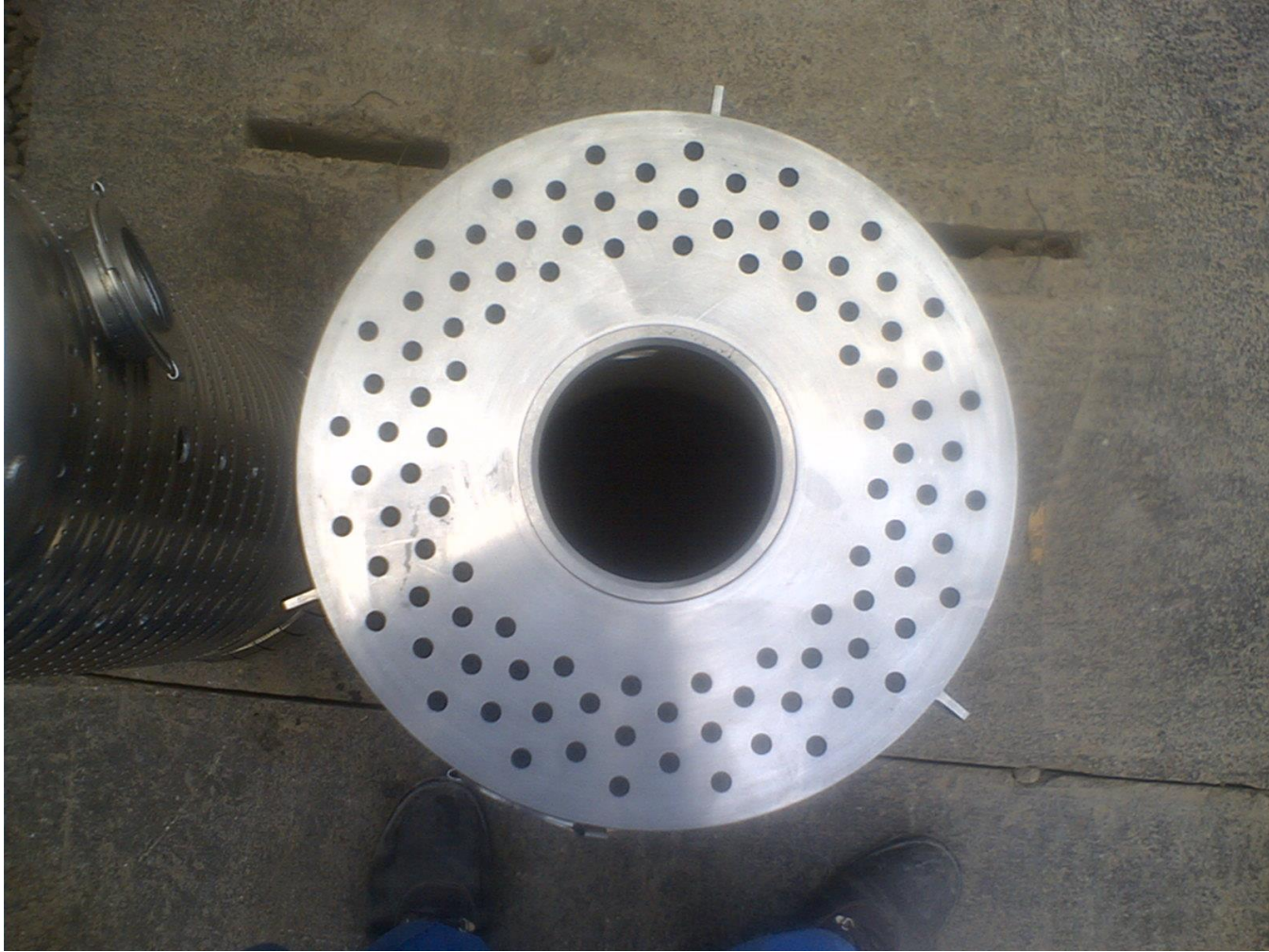

Liner (internal view)

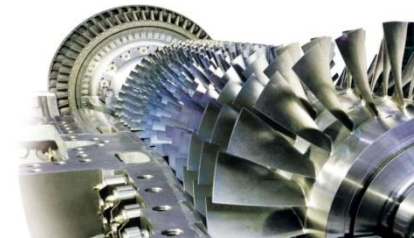
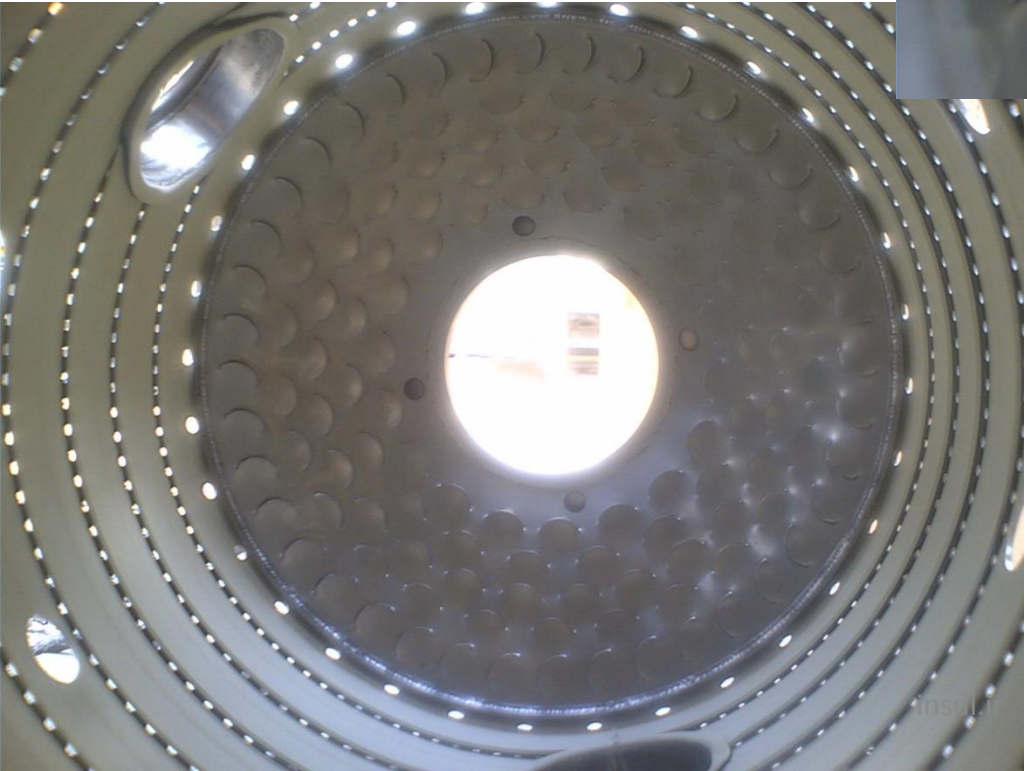



## Cross Fire Tube

- Single
- Couple (Male and Female)

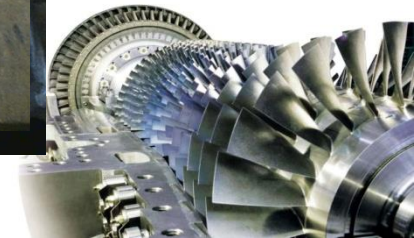



# Outer Cross Fire Tube

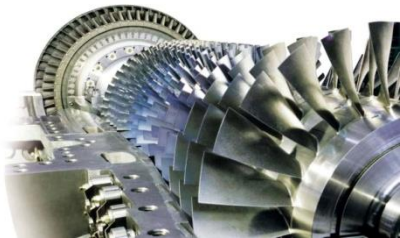
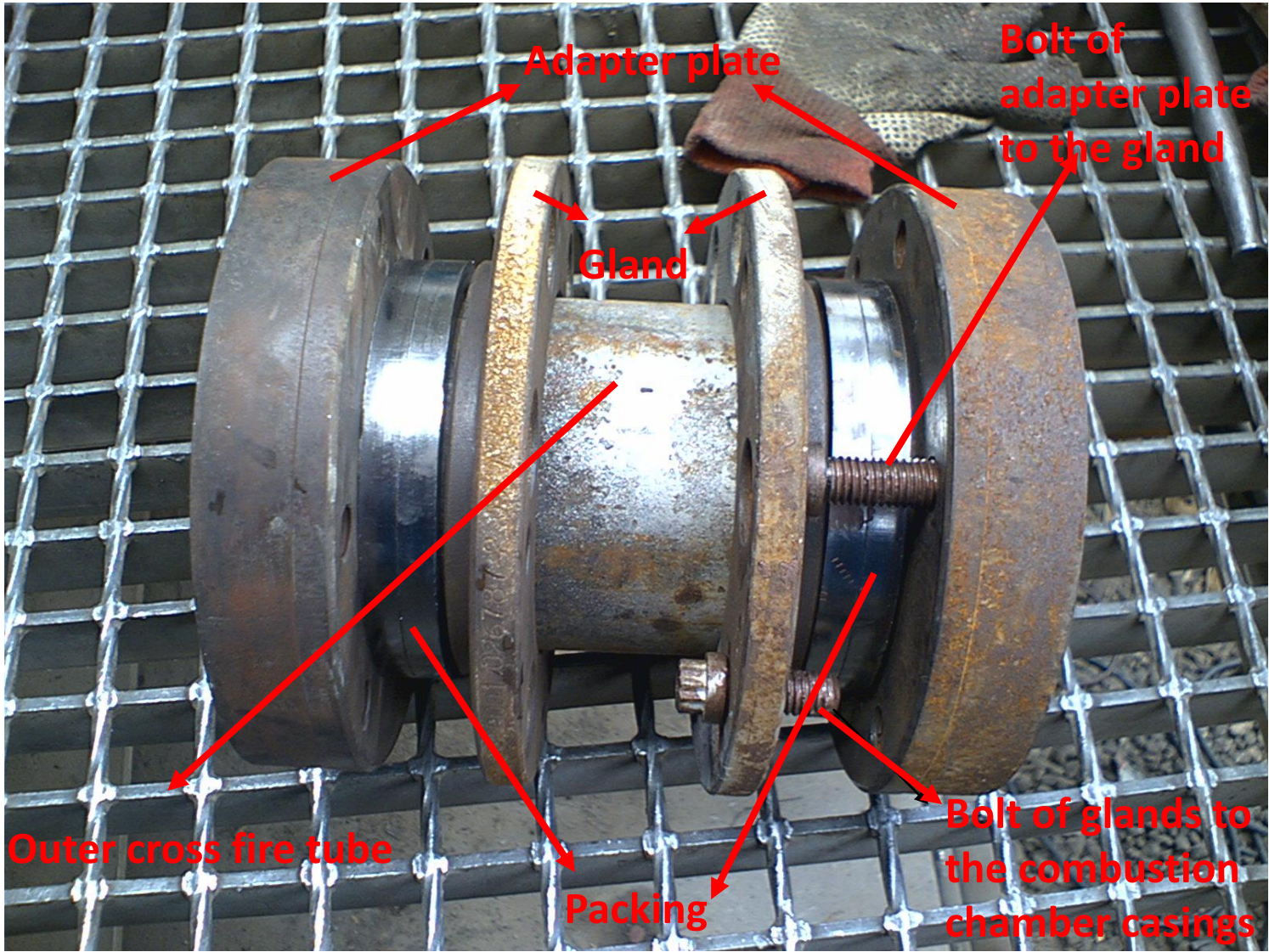



## Outer Casing

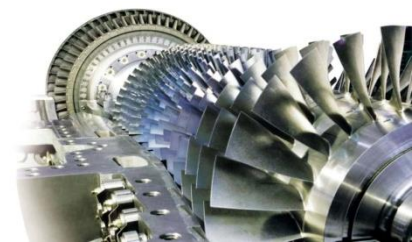
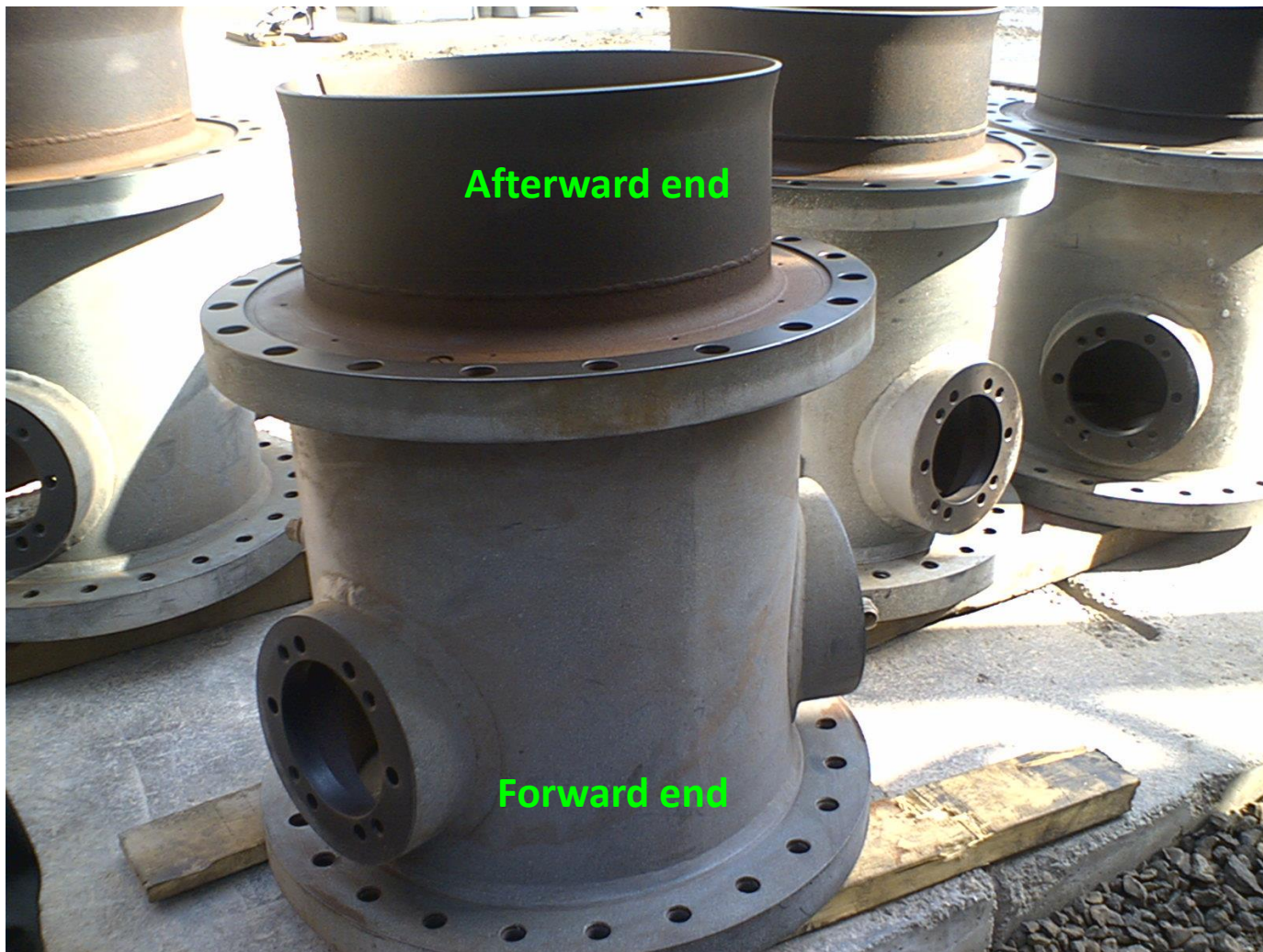



## Outer Casing





Cap





# Transition Piece





# Transition Piece

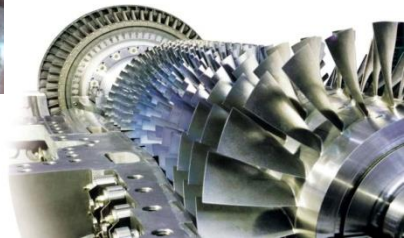
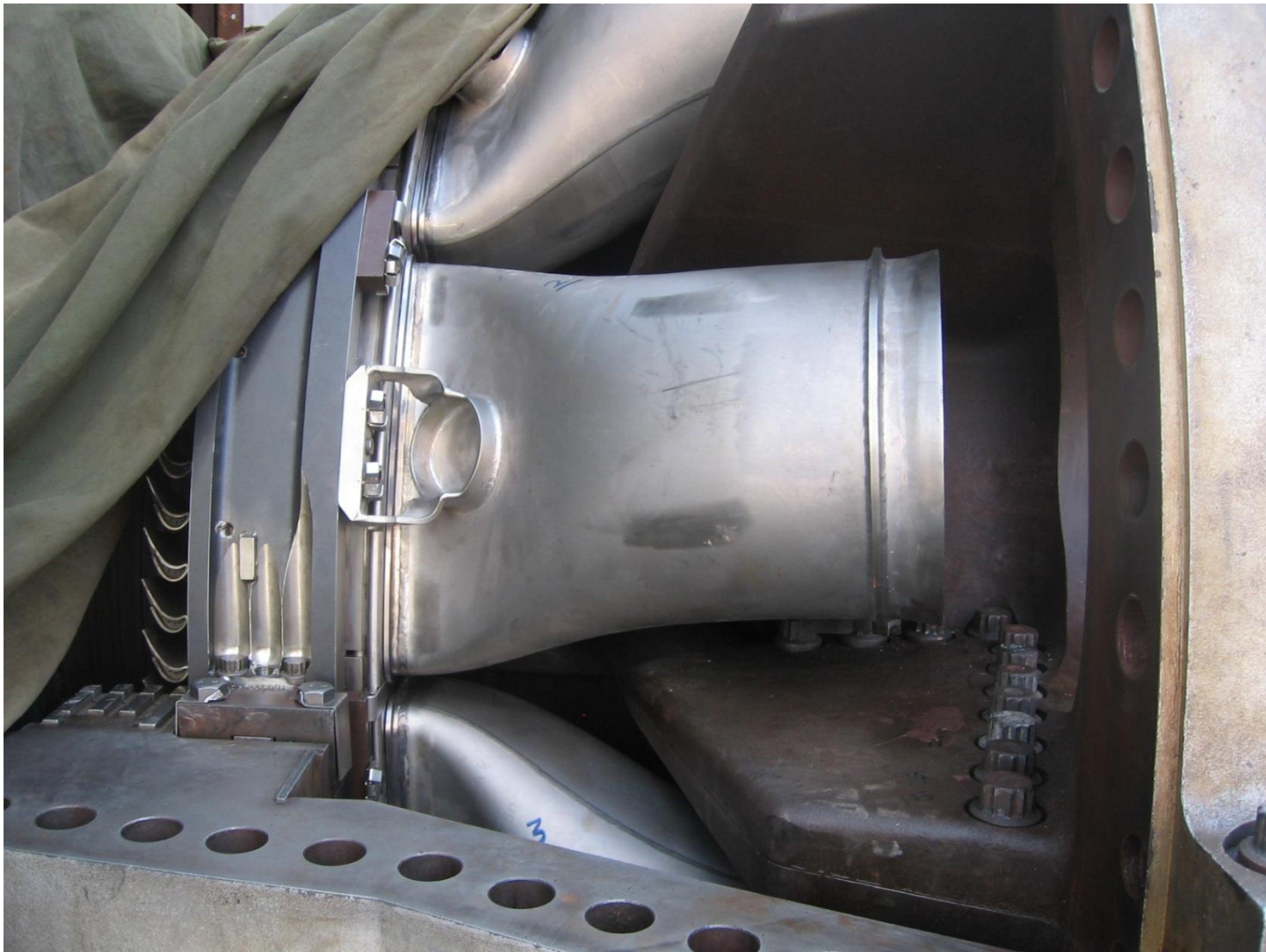

تولید کار بر اساس تبدیل فشار به سرعت

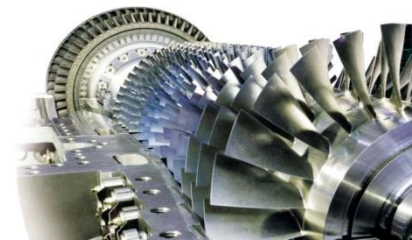
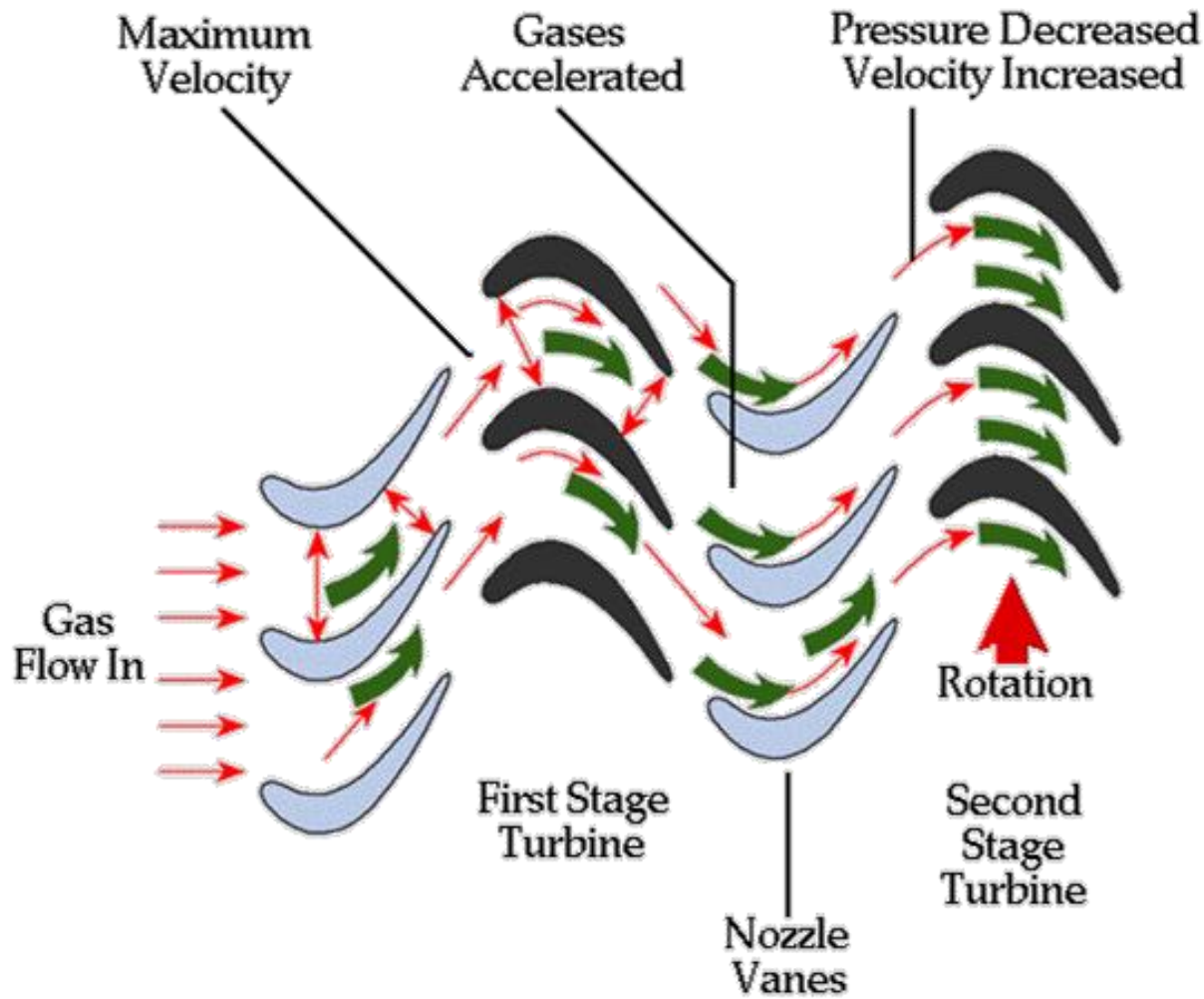



Nozzles Buckets

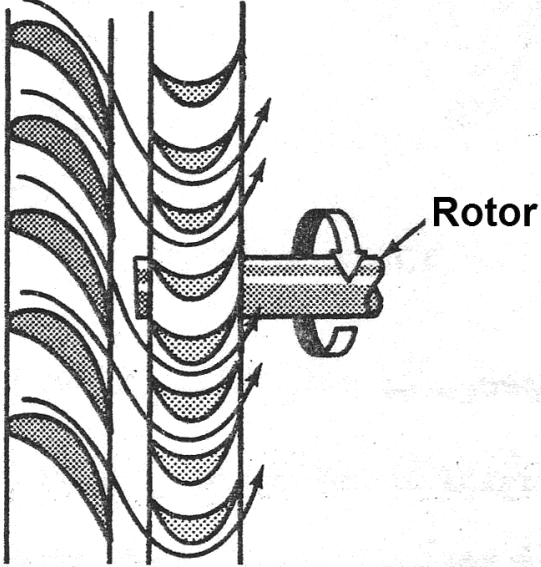

- ضربه ای (Impulse)
- عکس العملی (Reaction)
- ترکیبی (Compound)

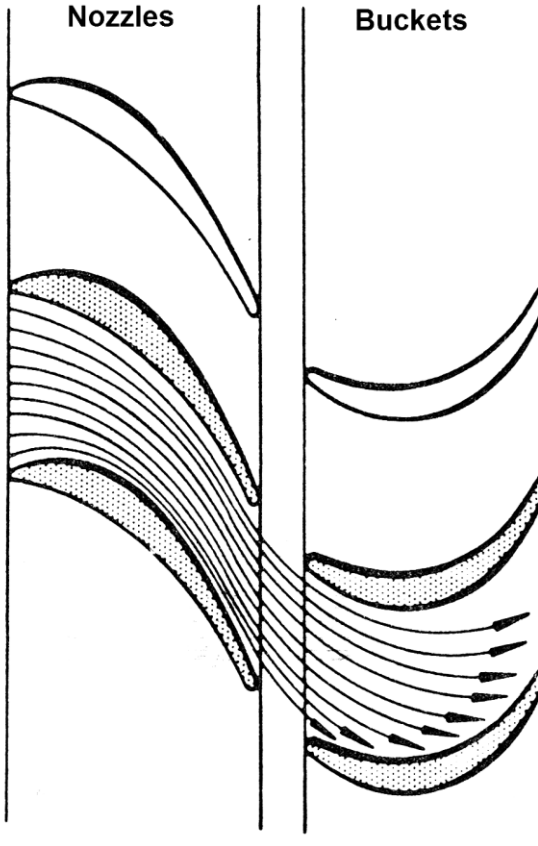

Nozzles Buckets

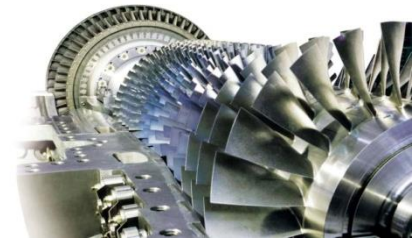
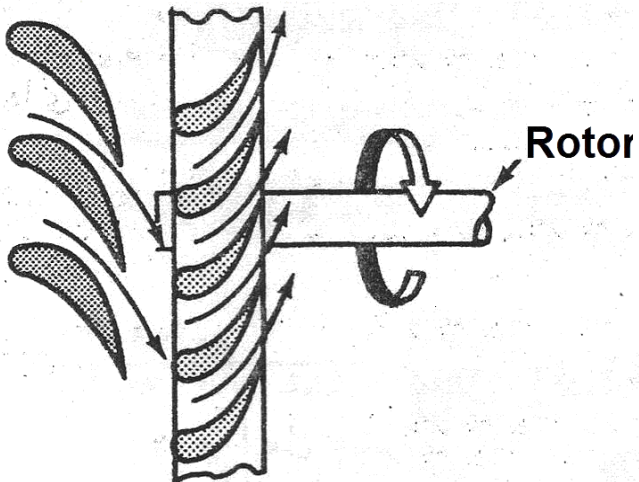

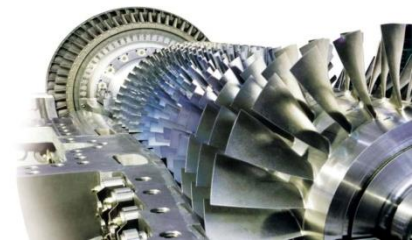
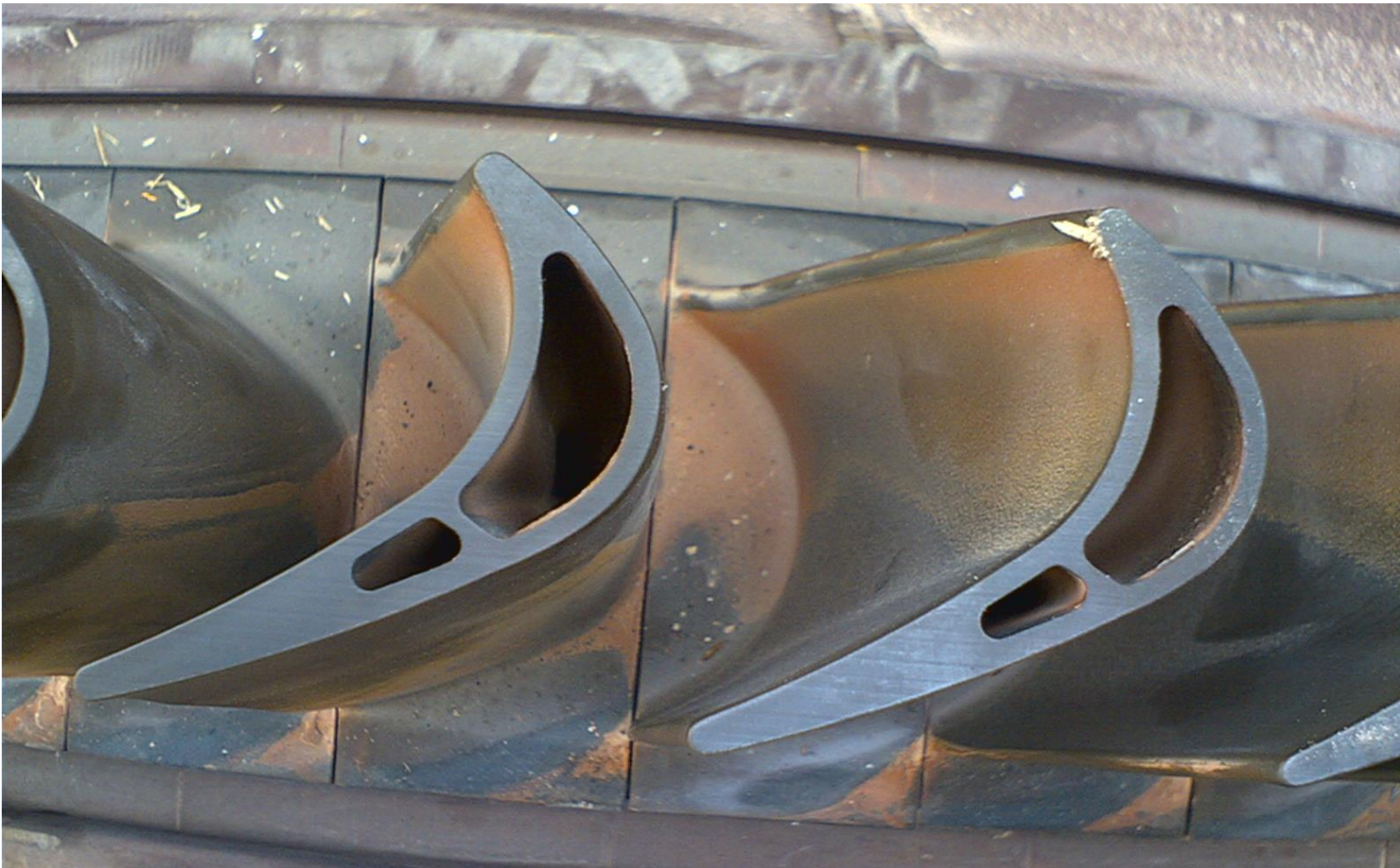



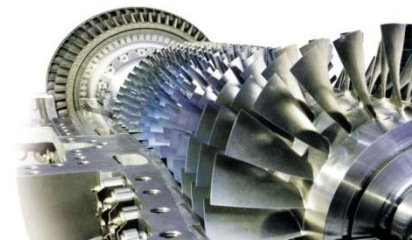
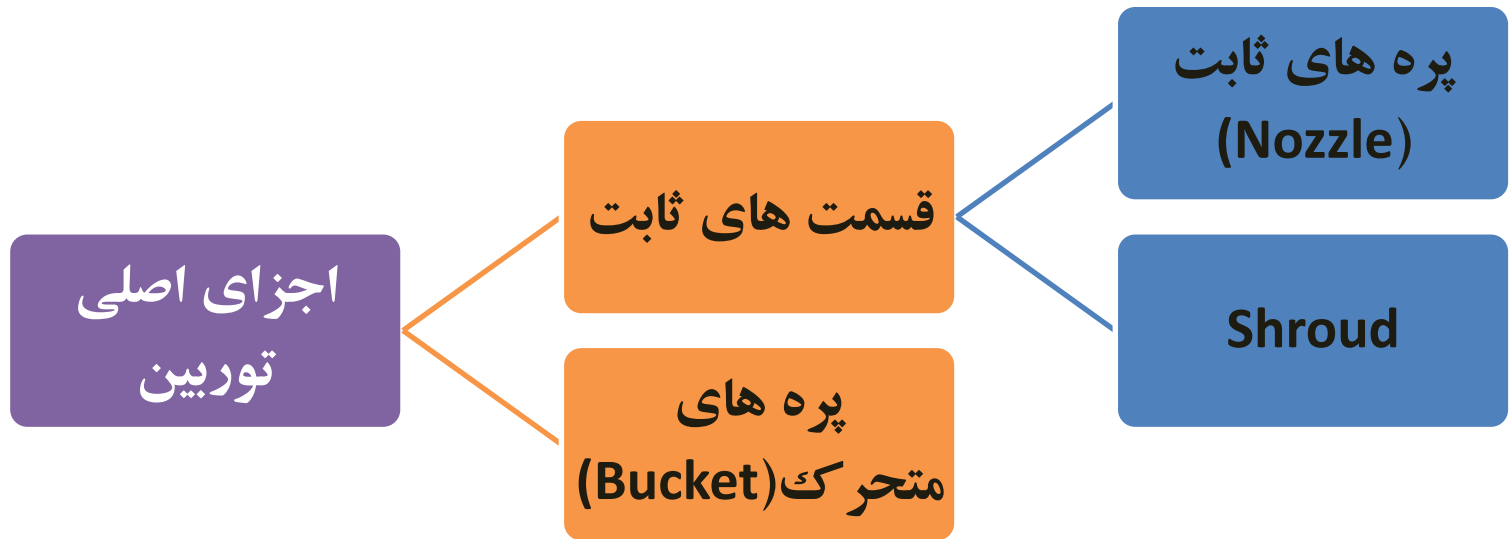

# پره های متحرک (Bucket)

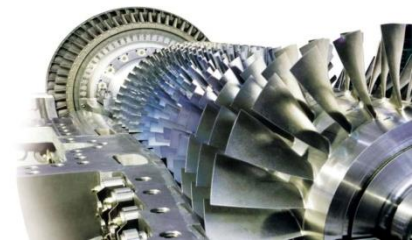



# پره های متحرک ردیف اول (First stage Bucket)

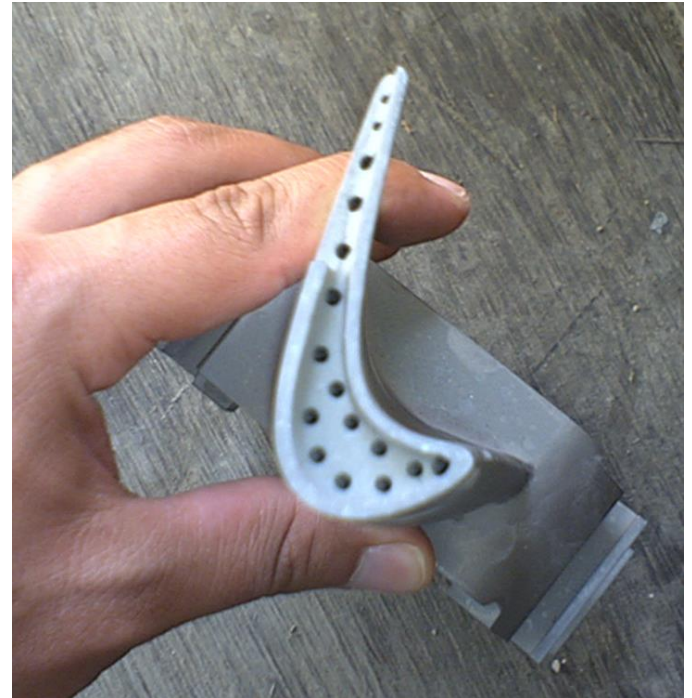

insdl.ir

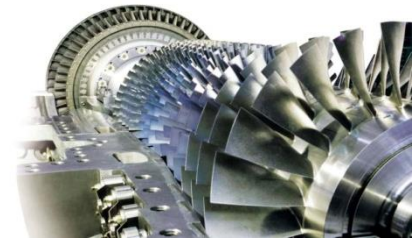

# پره های متحرک ردیف دوم (Second stage Bucket)

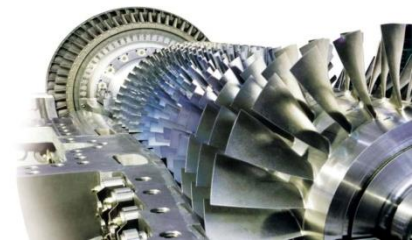
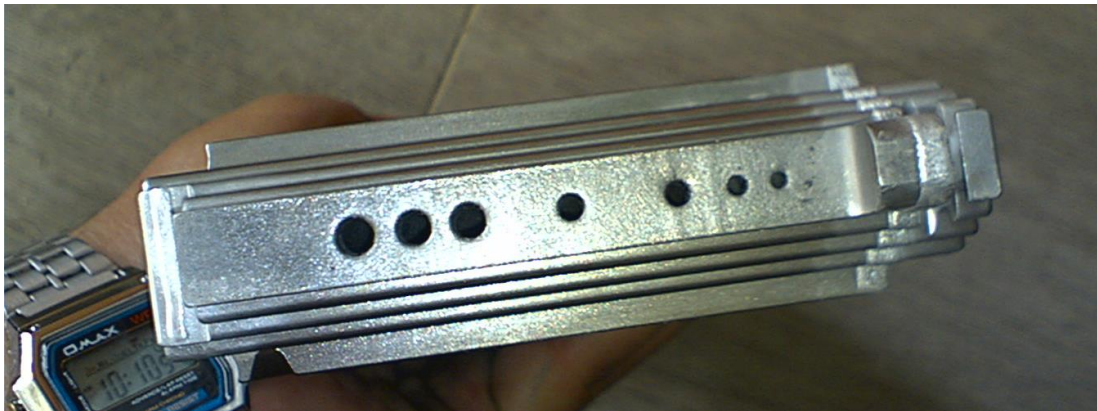
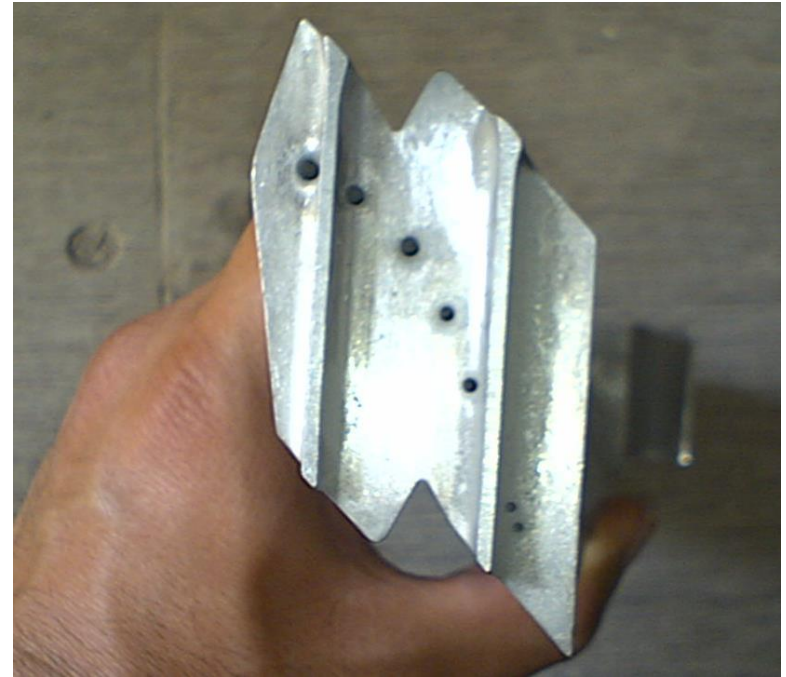



# پره های متحرک ردیف سوم (Third stage Bucket)



insdl.ir

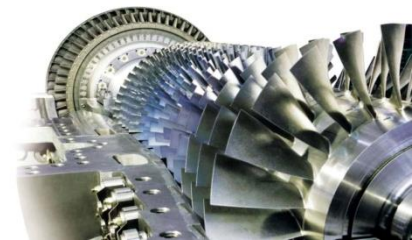

# شرودهای ردیف اول (First stage Shrouds)

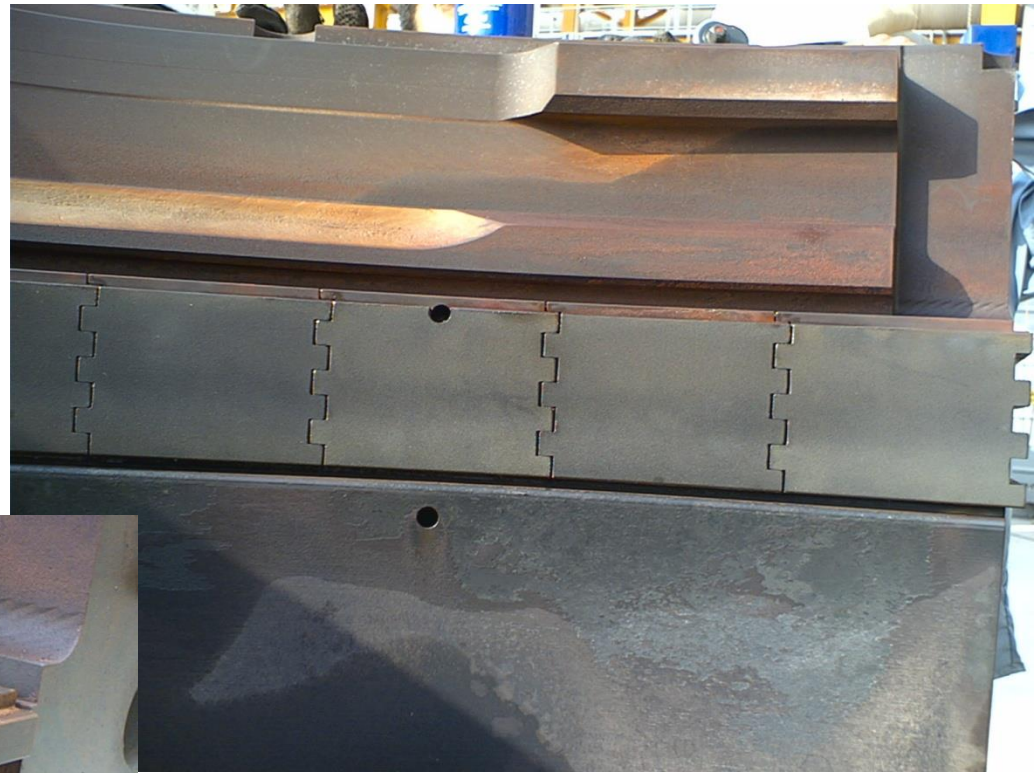

insdl.ir

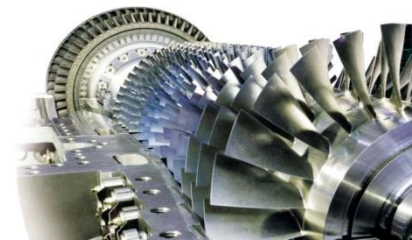



# نازل ردیف اول (First stage nozzle)

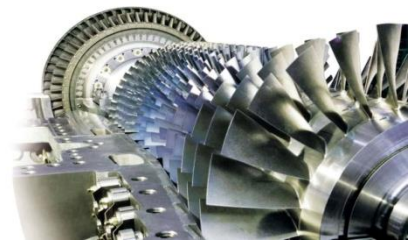

# خنک کاری نازل ردیف اول

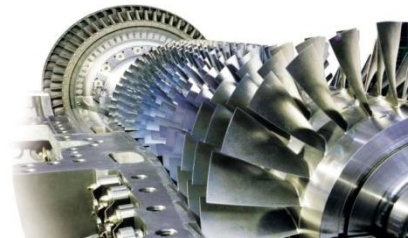
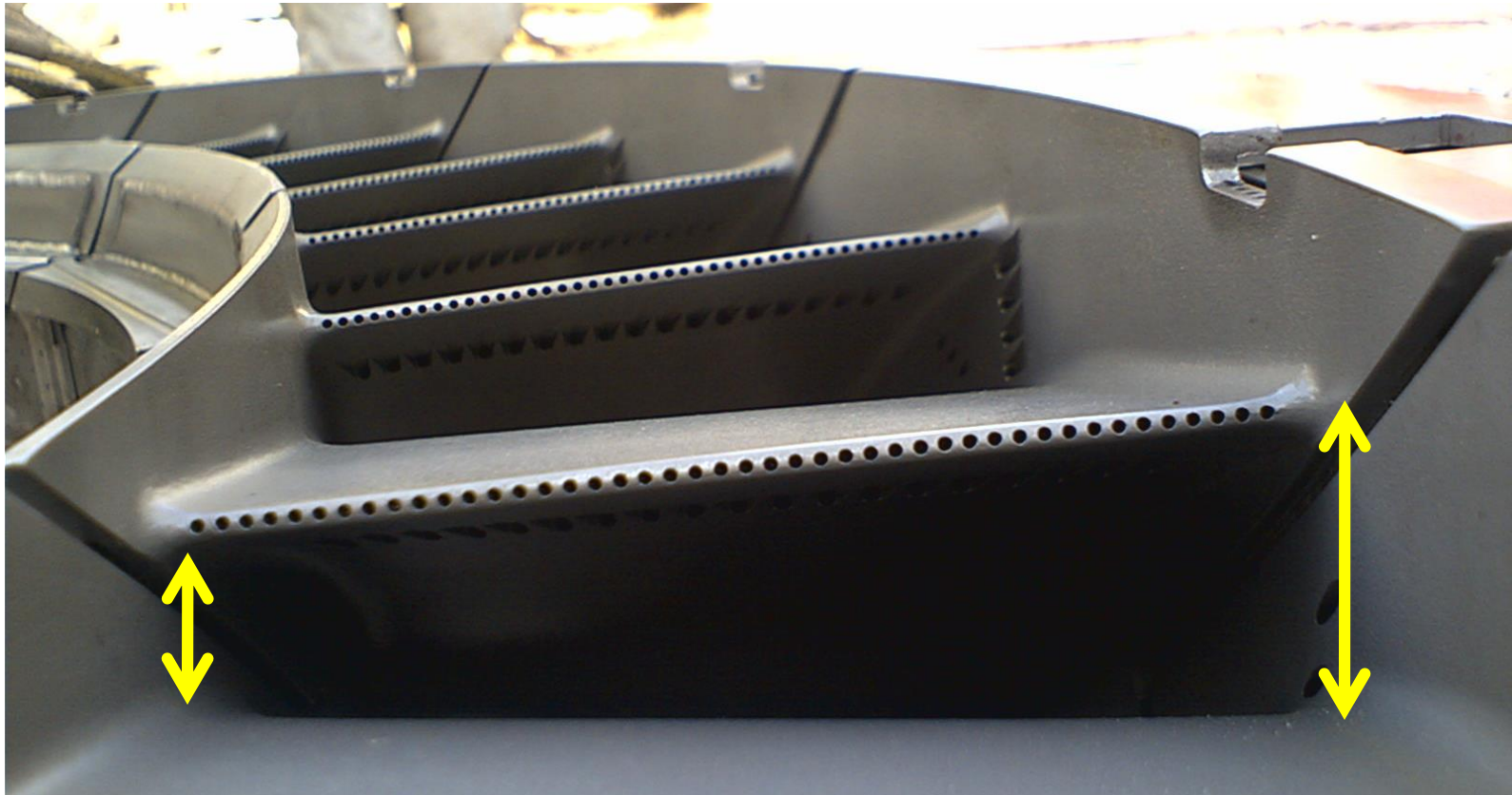



# خنک کاری نازل ردیف اول

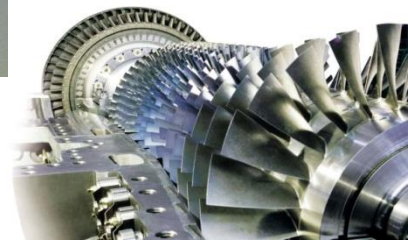
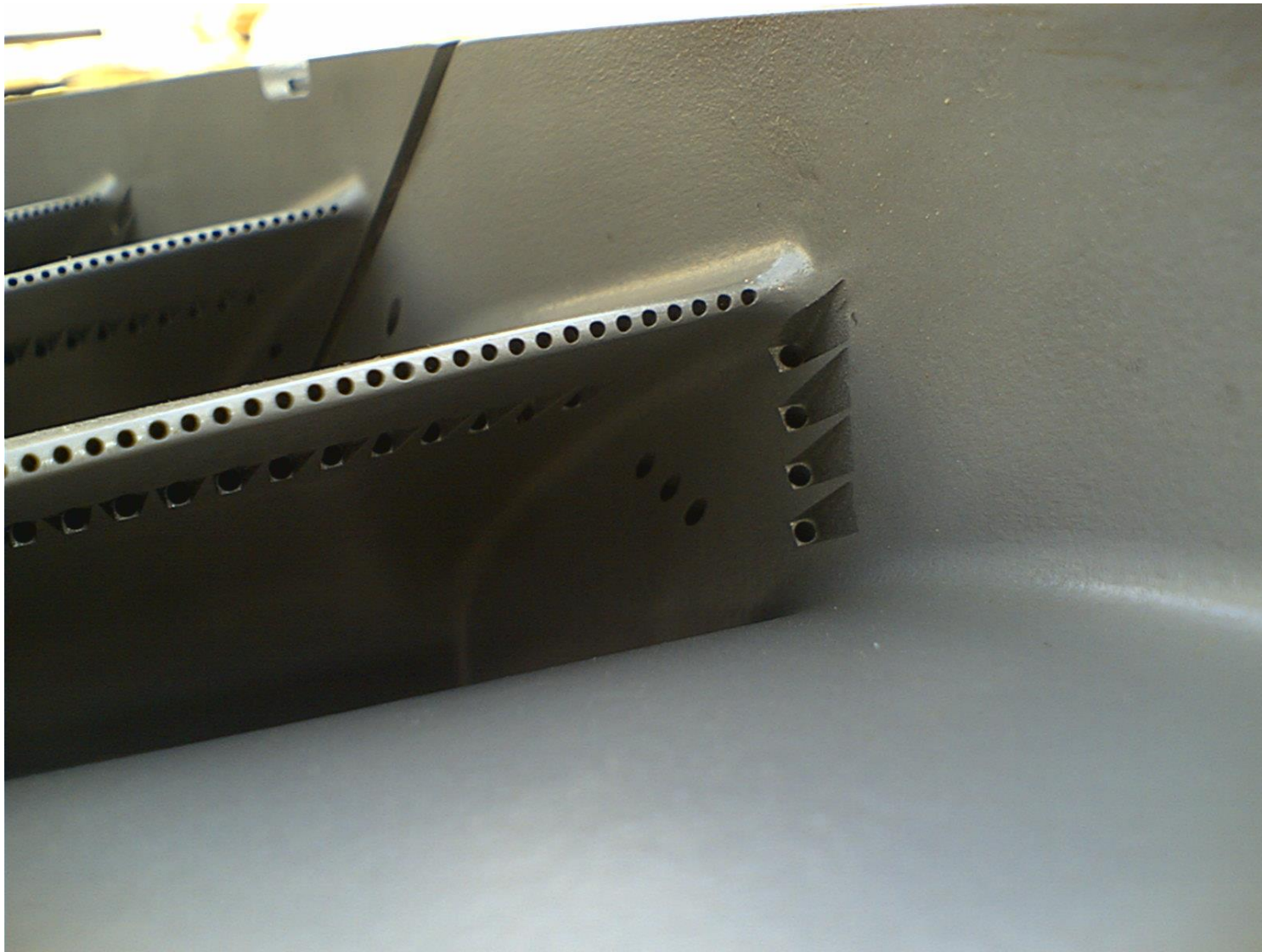

# خنک کاری نازل ردیف اول

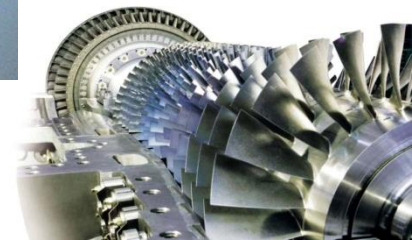



نازل - شروود و پره متحرک ردیف اول

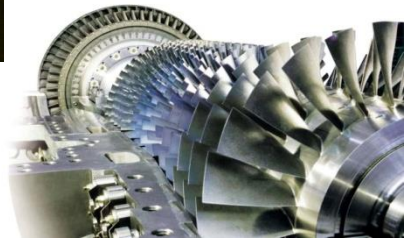
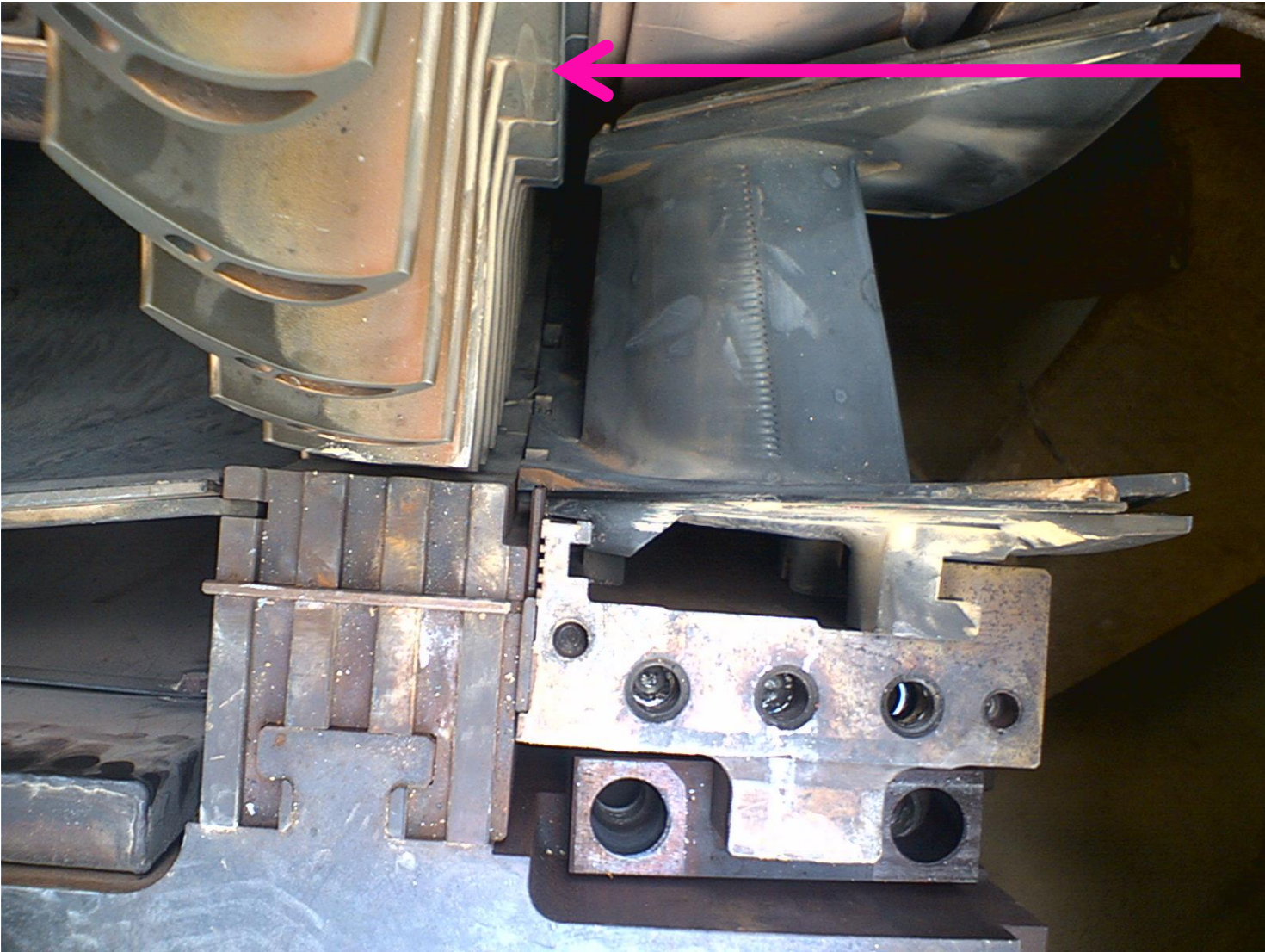



## شروود ردیف دوم (Second stage Shrouds)

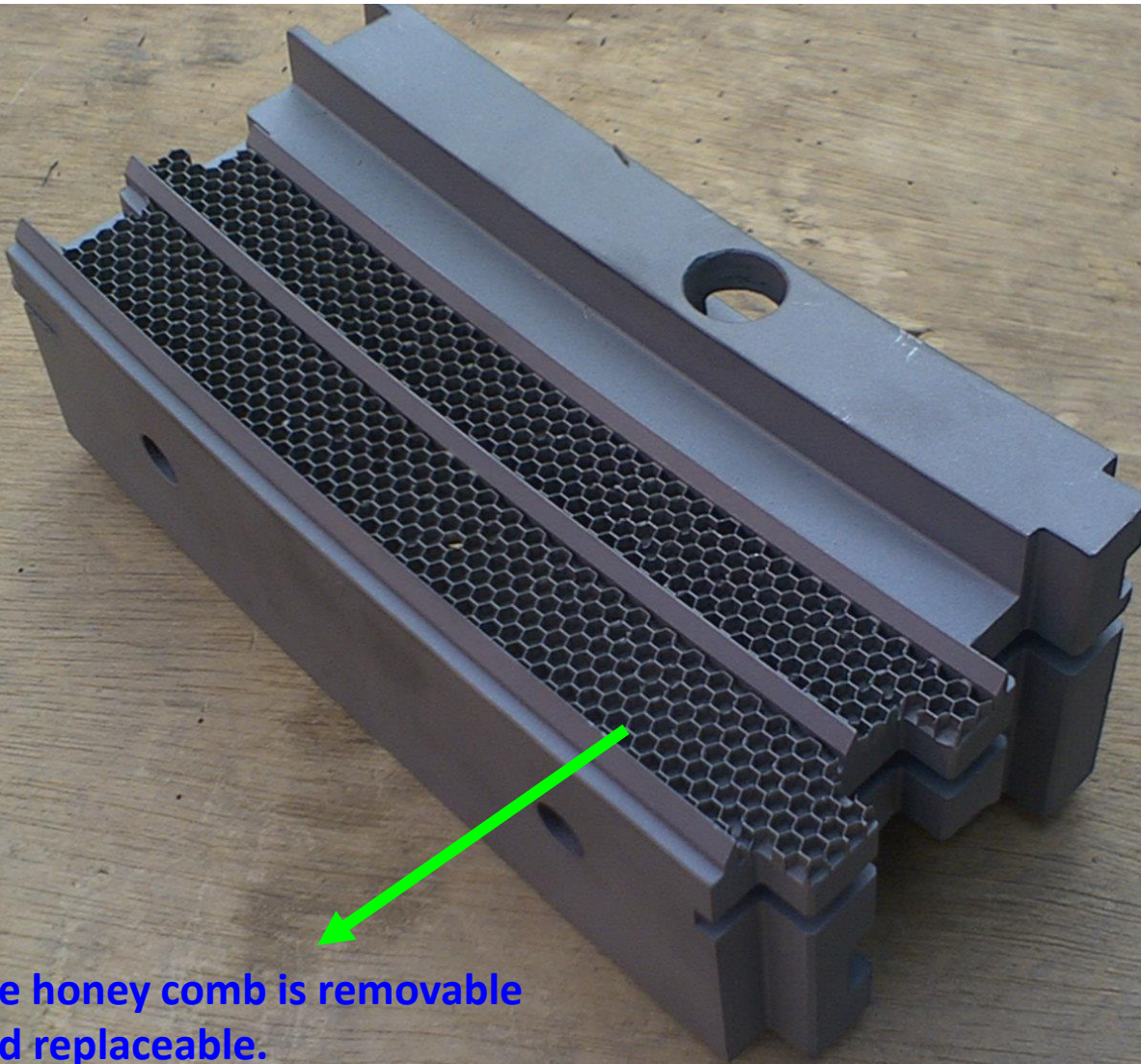

The honey comb is removable and replaceable.

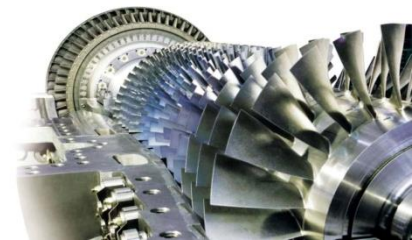



# نازلهای ردیف دوم (Second stage nozzles)

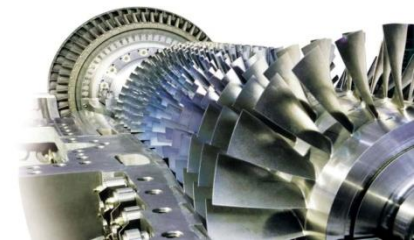
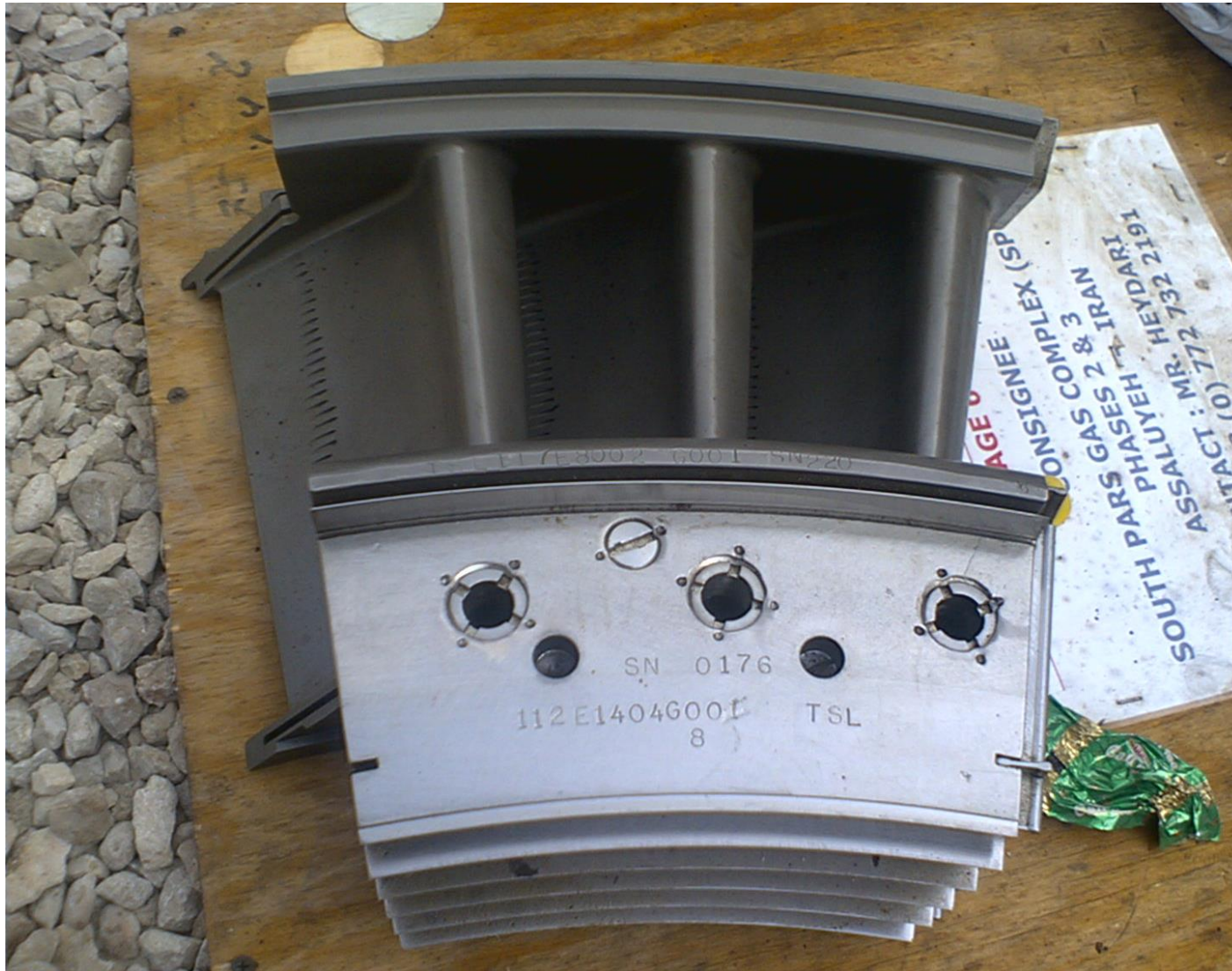

# خنک کاری نازل ردیف دوم

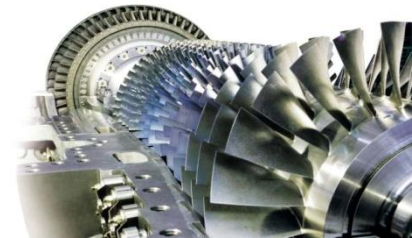



# نازل - شروود و پره متحرک ردیف دوم

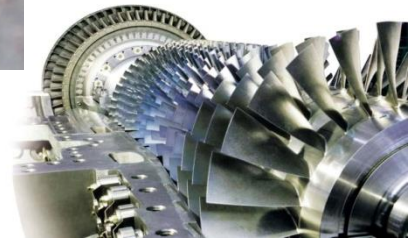

# شروود ردیف سوم (Third stage Shrouds)

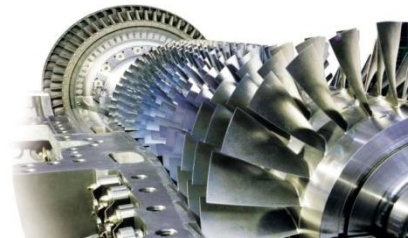
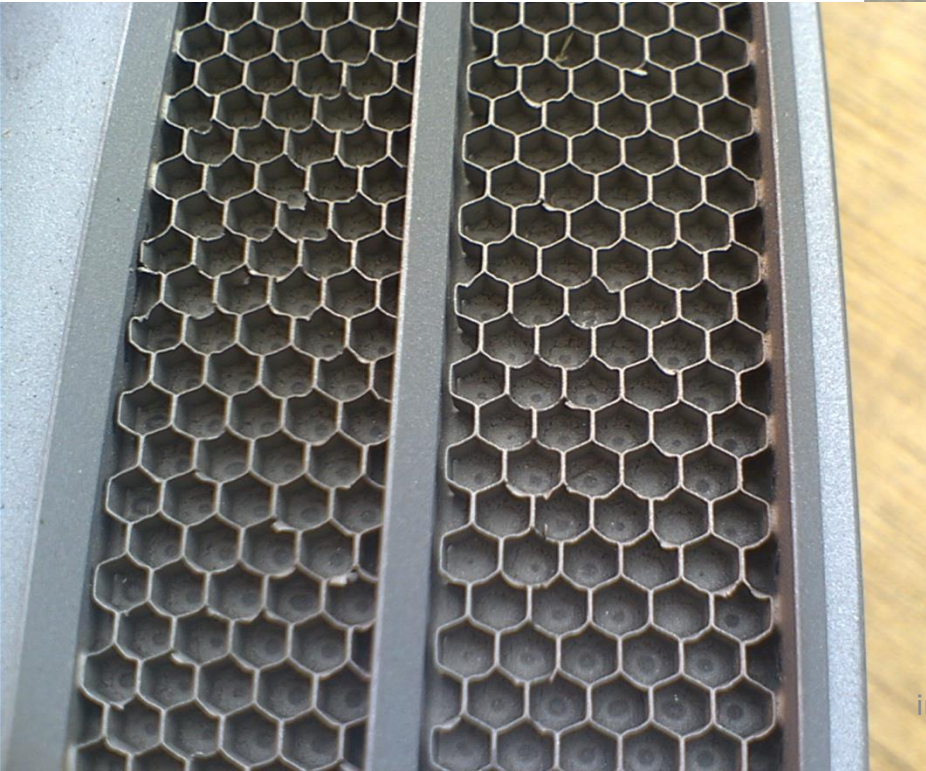
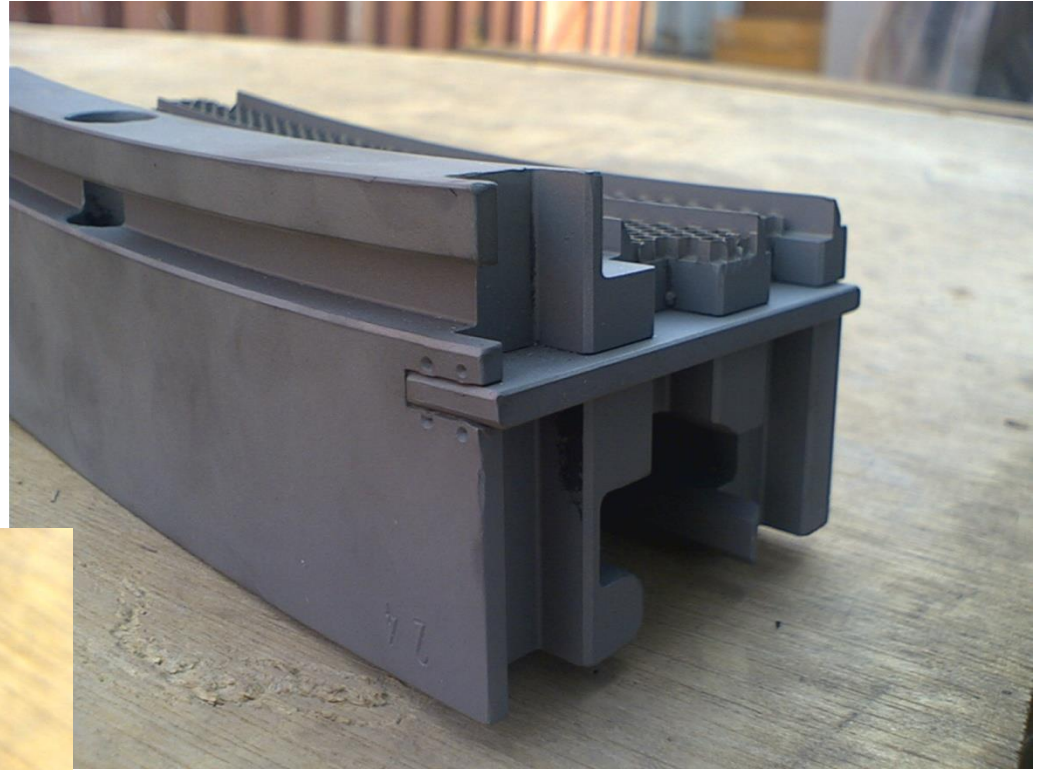



## نازلهای ردیف سوم (Third stage nozzles)

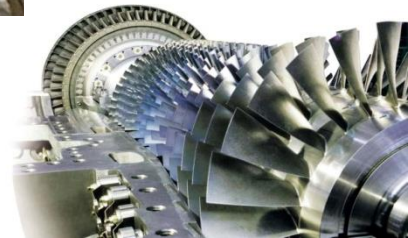



# خنک کاری نازل ردیف سوم

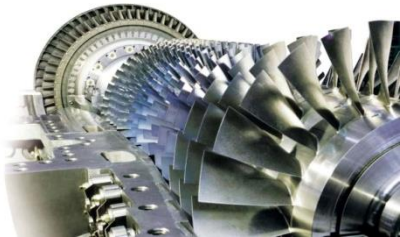
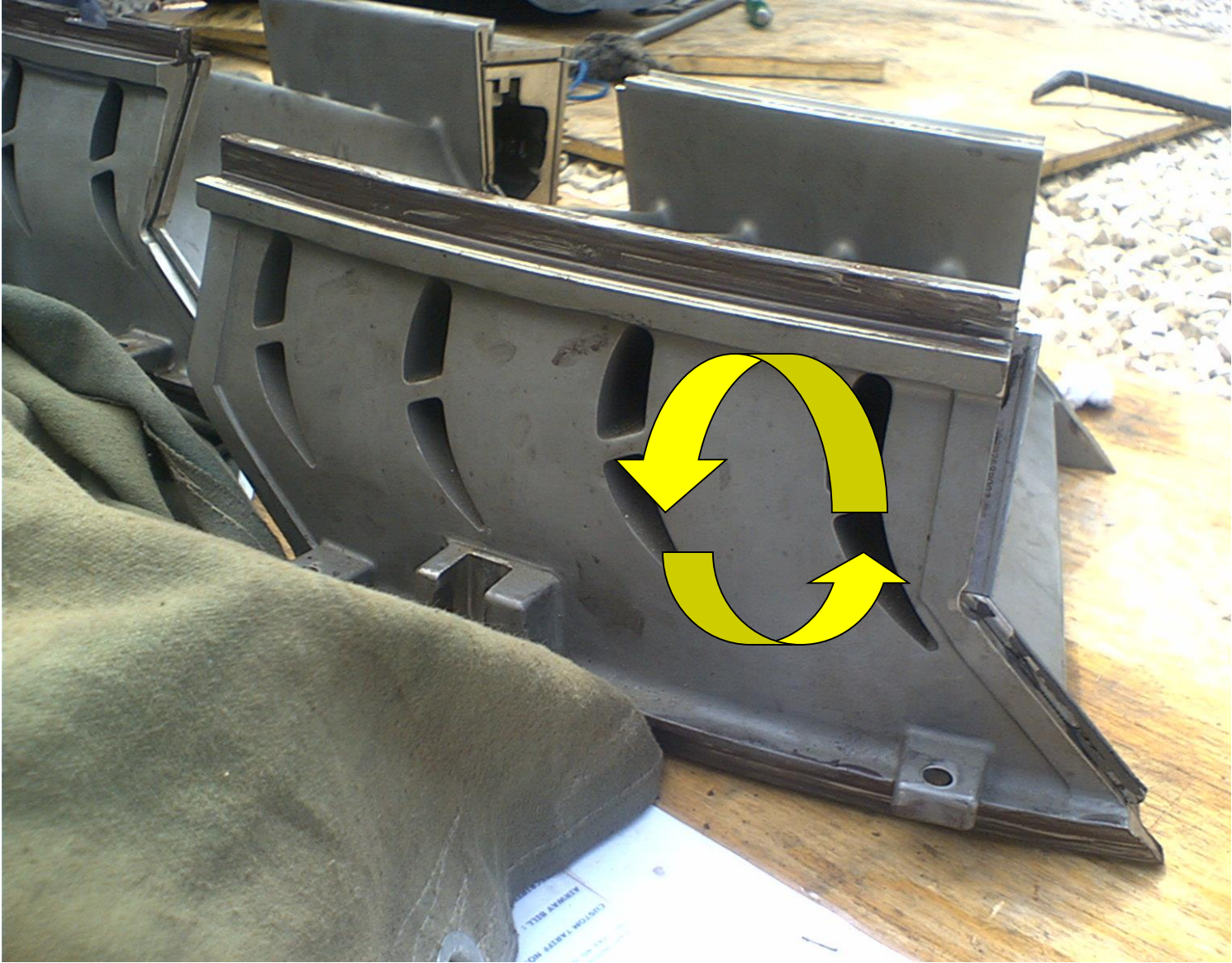



# شرودهای ردیف اول تا سوم

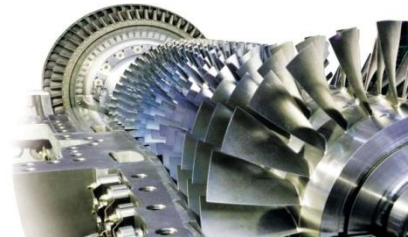
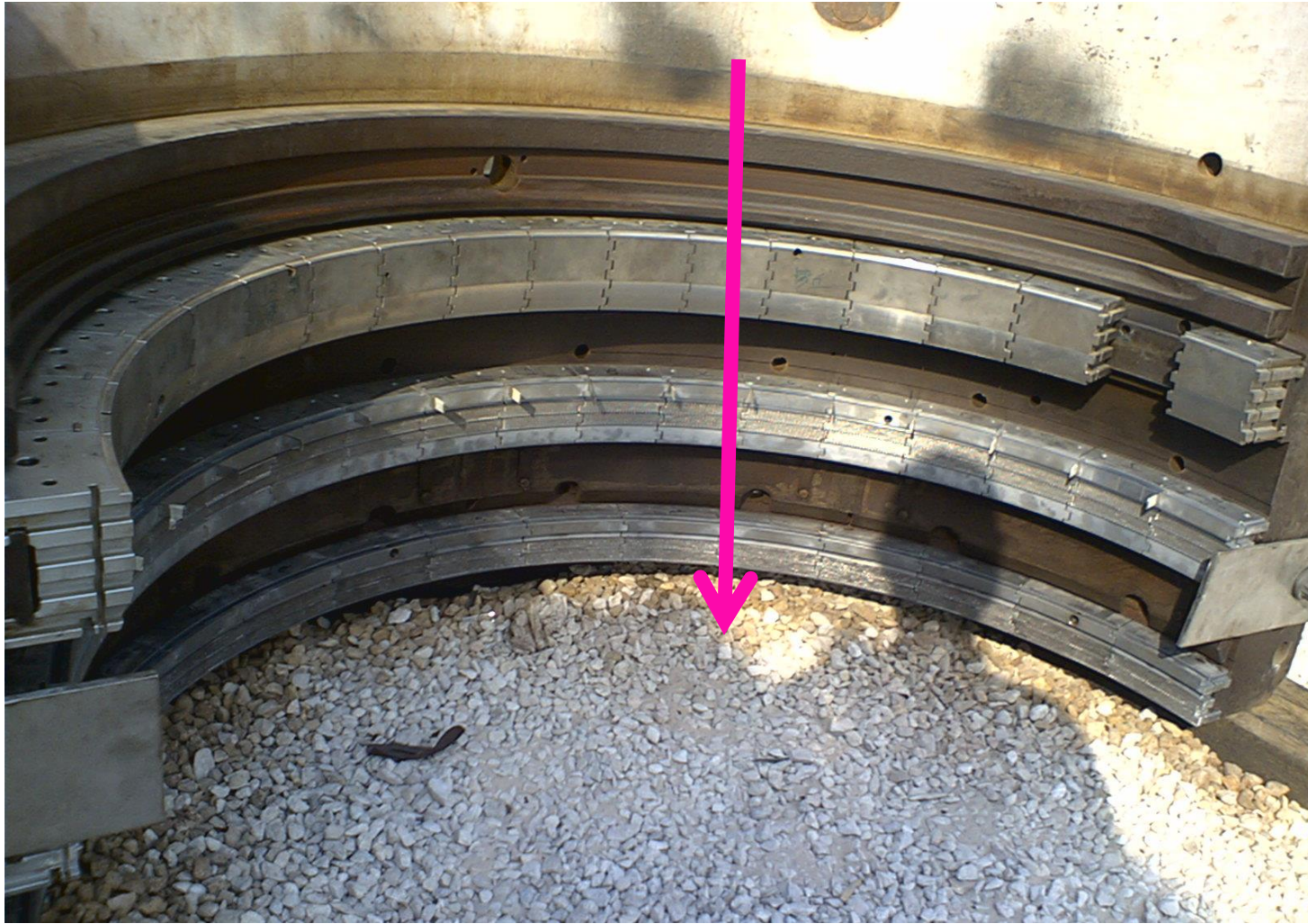



# شرودهای ردیف اول تا سوم در کنار نازل مرحله سوم





پره های متحرک (Bucket) ردیف اول تا سوم

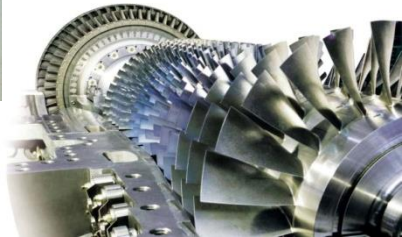
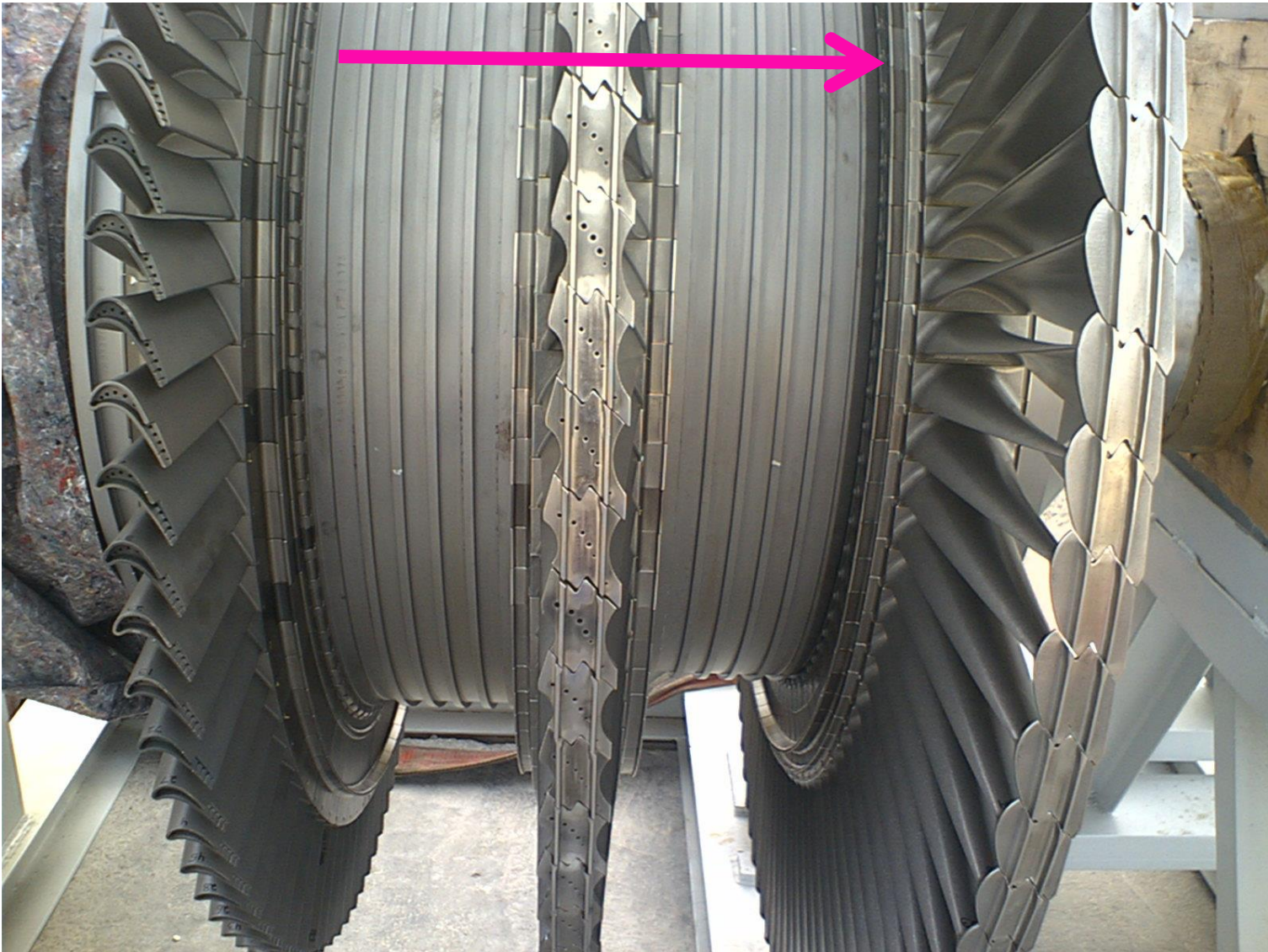



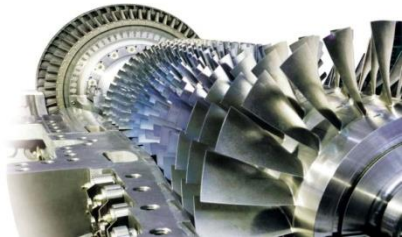
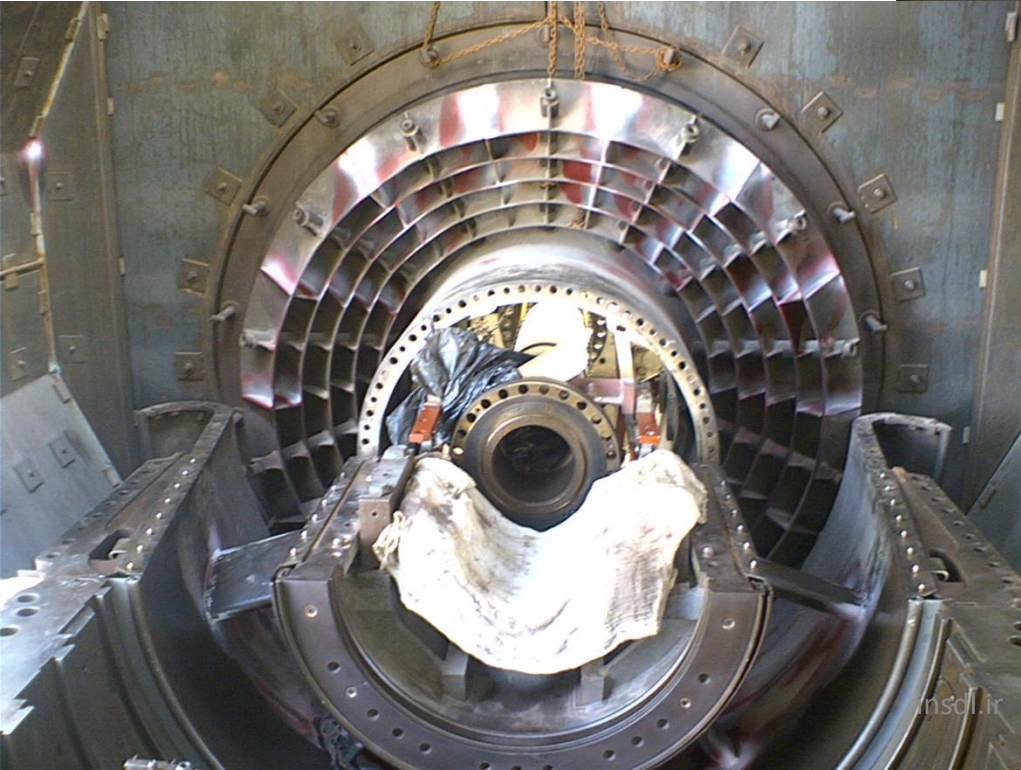





Exhaust hood

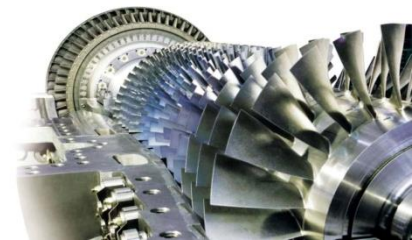

# اگزااست و پوسته توربین

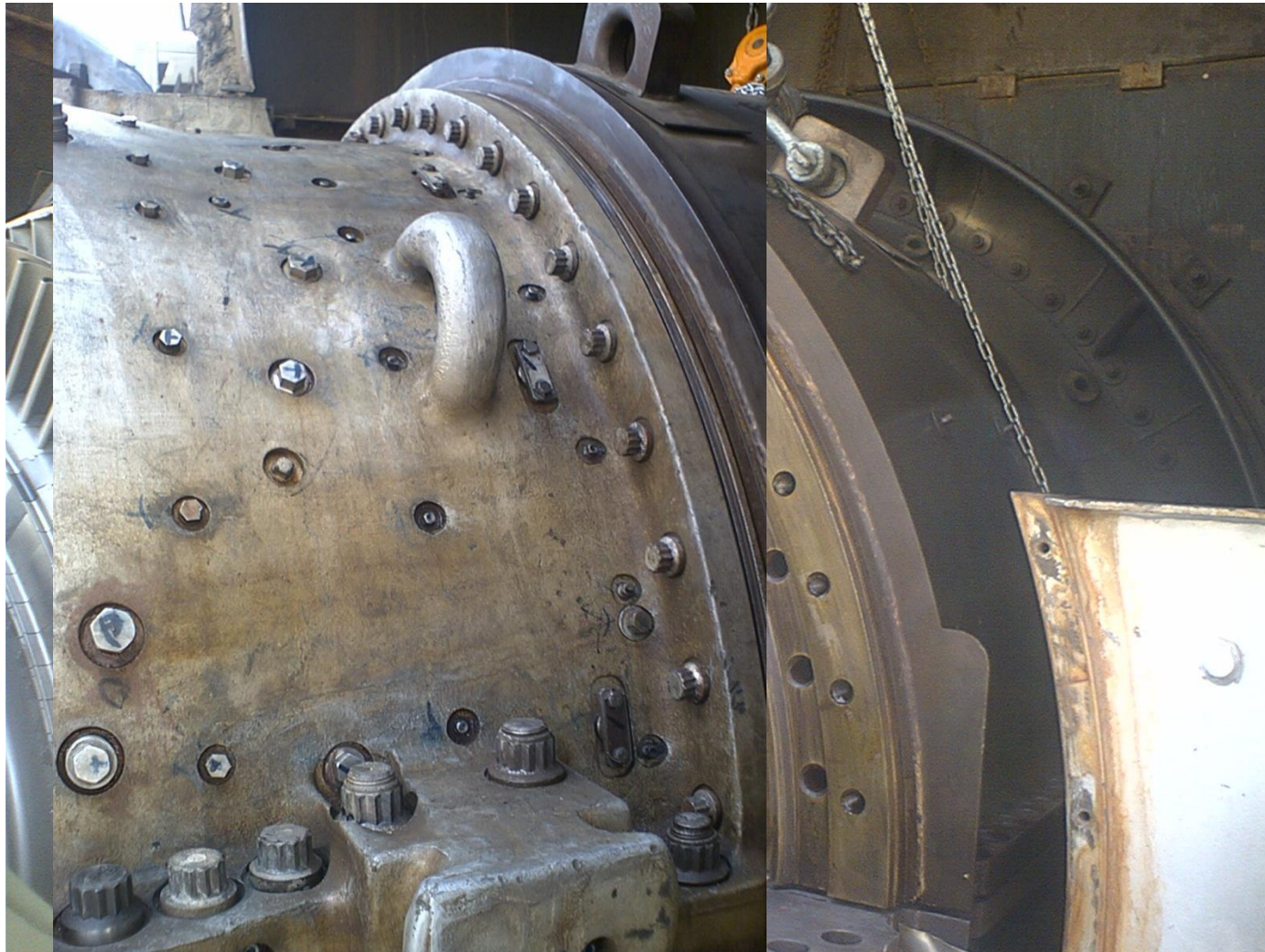



# Exhaust Thermocouples

<b>A</b>	TE-5081	37 °C
<b>B</b>	TE-5082	36 °C
<b>C</b>	TE-5083	37 °C
<b>D</b>	TE-5084	37 °C
<b>E</b>	TE-5085	36 °C
<b>F</b>	TE-5086	37 °C
<b>G</b>	TE-5087	36 °C
<b>H</b>	TE-5088	36 °C
<b>I</b>	TE-5089	37 °C
<b>J</b>	TE-5090	37 °C
<b>K</b>	TE-5091	37 °C
<b>L</b>	TE-5092	37 °C
<b>M</b>	TE-5093	37 °C

EXH.MEDIAN TEMP.	37 °C
COMB.ALLOW.SPREAD	103 °C
COMB.ACT.SPREAD	2 °C

**SYNONIM**

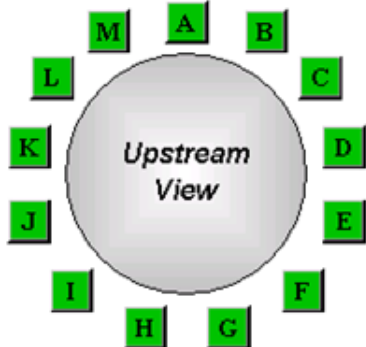

OPERATING DATA	
UNIT NORM.STATE	STARTUP STATUS
NORM.STAT.SEL.	#####
NORM.STAT.FIELD	NOT READY TO START
FUEL STROKE CTRL	STARTUP
FUEL STROKE REF.	0 %
FLAME DETECTION	
H.P.SHAFT SPEED	0.00 %
L.P.SHAFT SPEED	0.00 %
TURB.NOZZLE POS.	-10.57 degrees
COMP. PRESS.DISCH.	0.00 Bar
COMP.TEMP.DISCH.	-78.29 °C

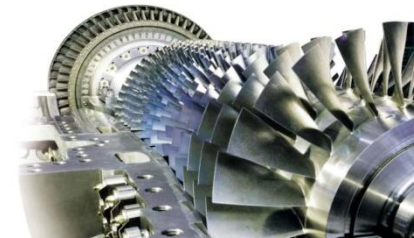
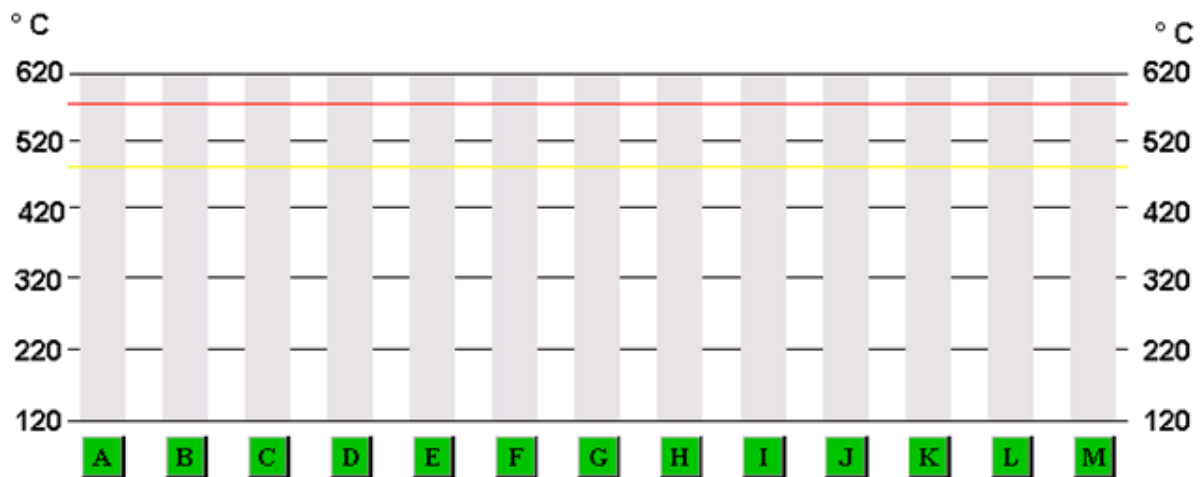

# ترموکوپل های اگزاست

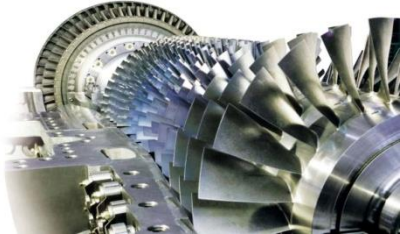



# روند تغییرات دما- فشار و سرعت سیال عامل در توربین گاز

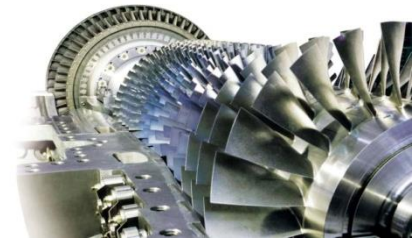
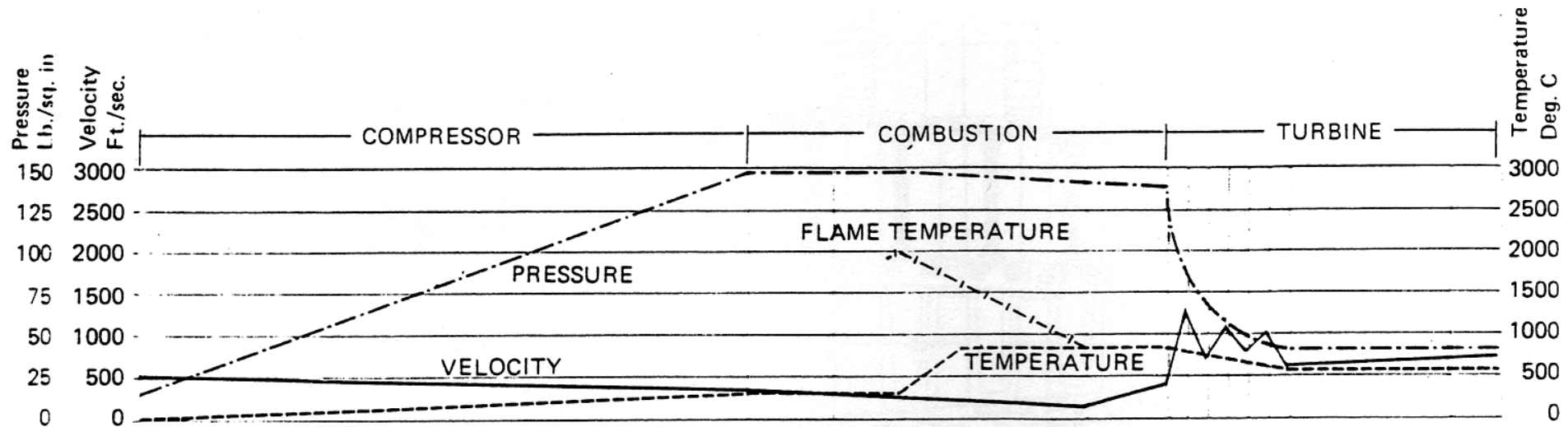

# تجهيزات جانبی (Accessory Equipments)

## روانکاری (Lubrication)

مخزن (Reservoir)

پمپها

اصلی (Main)

کمکی (Auxiliary)

اضطراری (Emergency)

فیلتر

خنک کن هوایی

شیر کنترل سه راهی دمایی (TCV)

جدا کننده رطوبت روغن (Oil mist separator)

## سیستم هیدرولیک (Hydraulic system)

فیلتر

پمپها

اصلی (Main)

کمکی (Auxiliary)

کلاچ

محرك IGV

GCV & SRV

## جعبه دنده ها

جعبه دنده کمکی (Accessory gearbox)

جعبه دنده بار (Load gearbox)

## سیستم سوخت رسانی

فیلتر

کنترل سوخت

## تجهيزات راه اندازی (Starting means)

موتور الکتریکی یا دیزل

مبدل گشتاور (Torque convertor)

کلاچ (Ratchet)

## سیستم تهویه (Ventilation system)

فنهای خنک کننده (Compartment cooling fans)

اگزاست فنها (Exhaust fans)

## سیستم شستشوی کمپرسور (Offline compressor washing)





# جعبه دنده کمکی (Accessory gearbox)

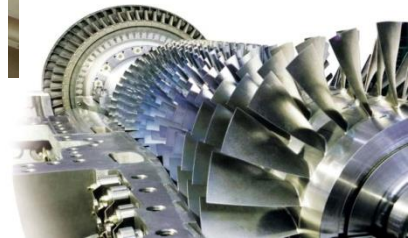
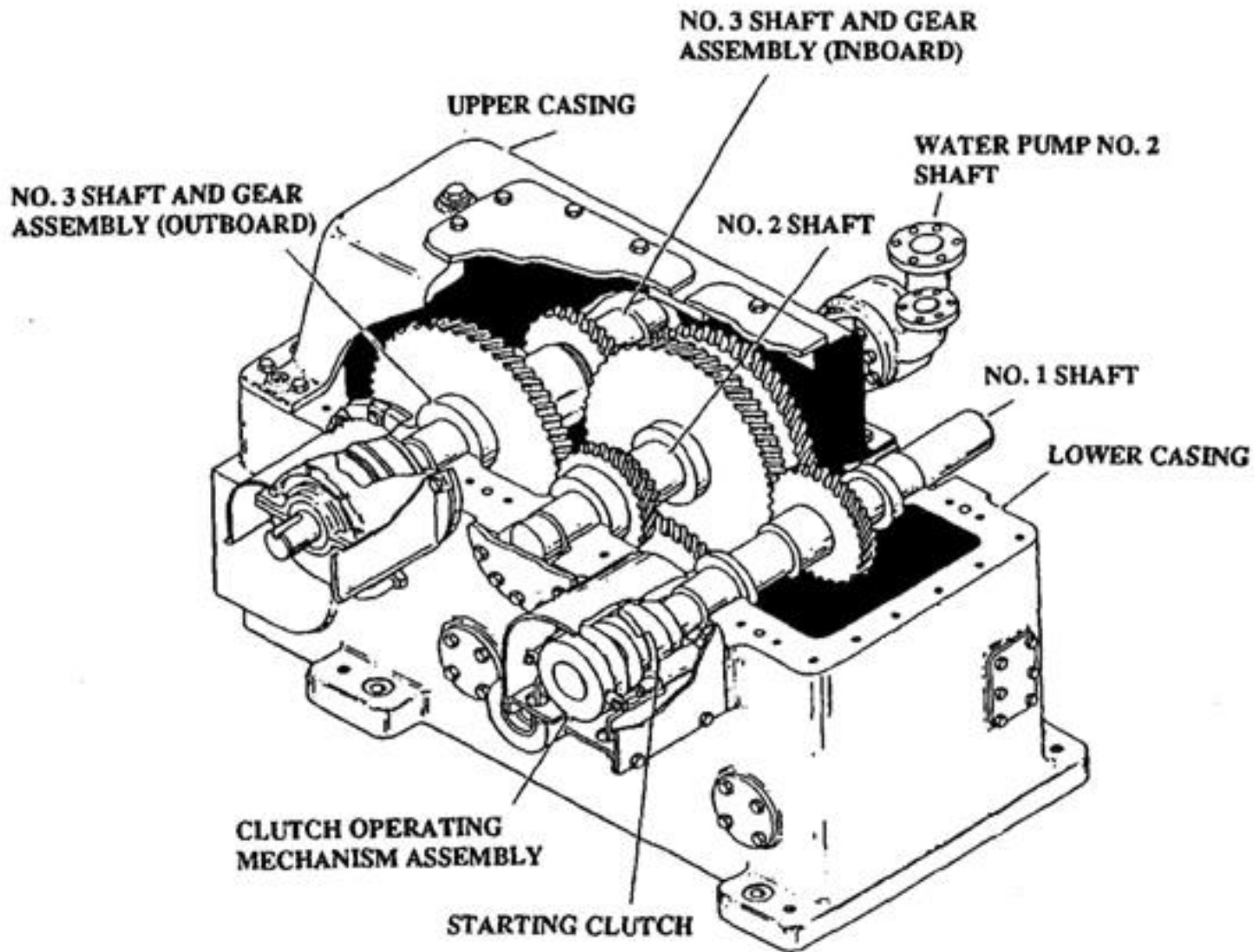

# جعبه دنده کمکی (Accessory gearbox)

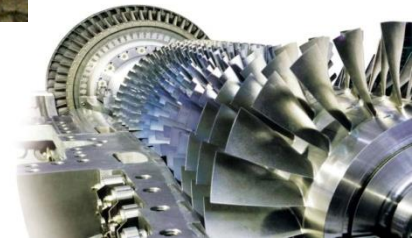
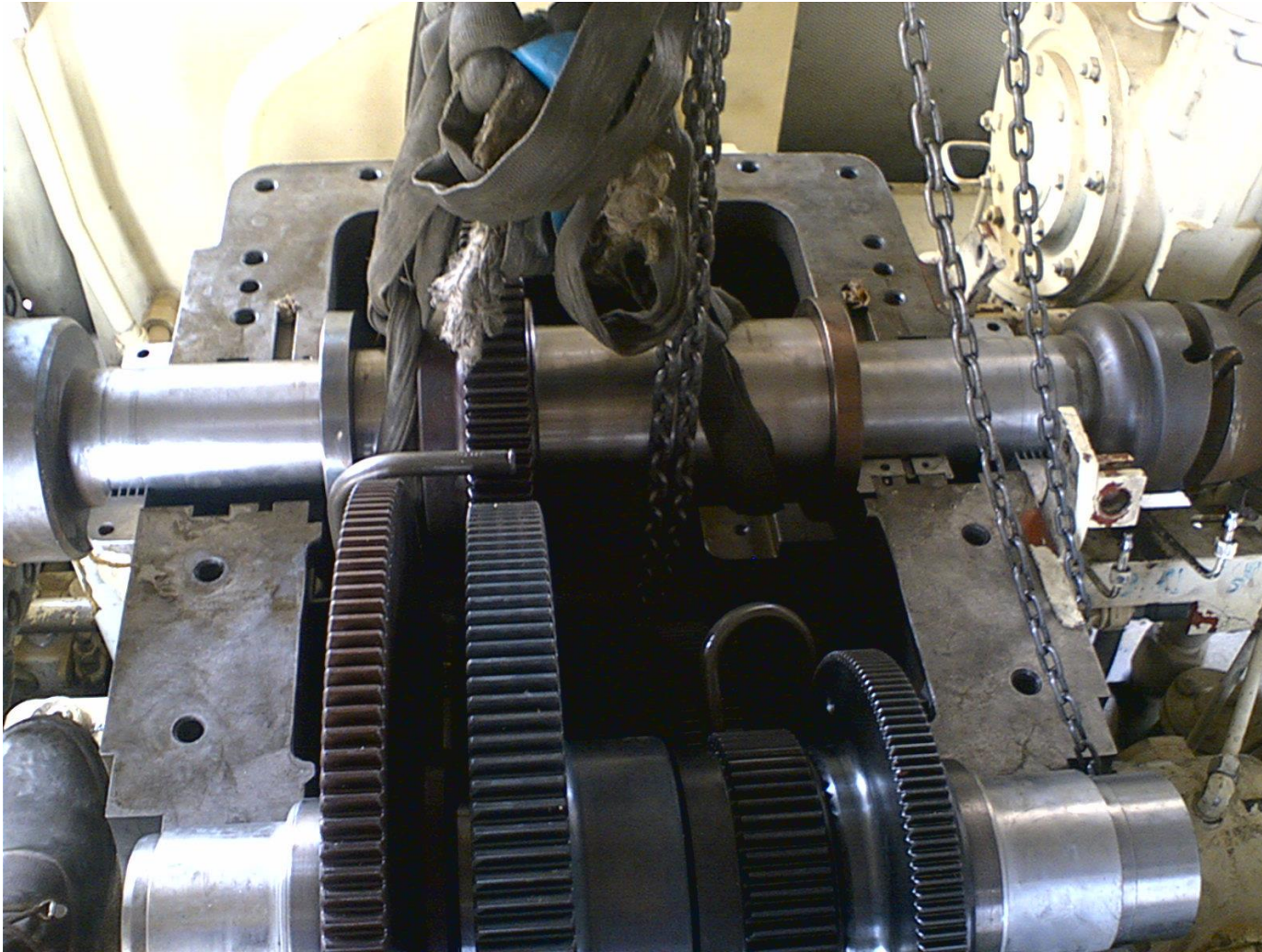



جعبه دنده بار (Load gearbox)

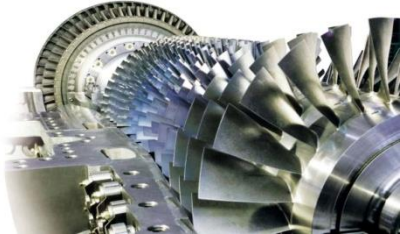

جعبه دنده بار (Load gearbox)

LSS : Low speed shaft



HSS : High speed shaft

insdl.ir

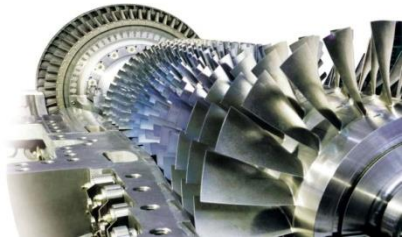



# کنترل سوخت: SRV & GCV

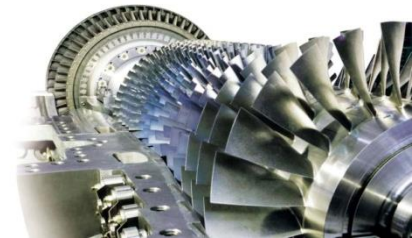

# موتور راه اندازی (Starting motor)

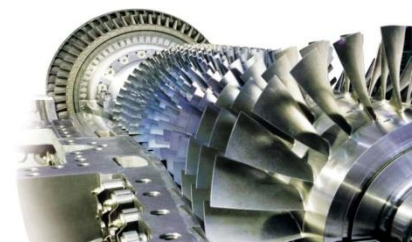



# مبدل گشتاور (Torque convertor)

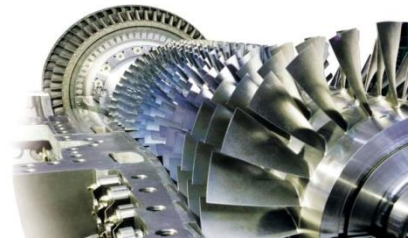

Principle of  
Hydrodynamic  
Torque Converter

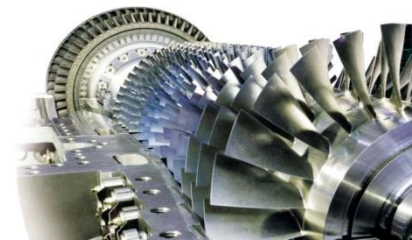
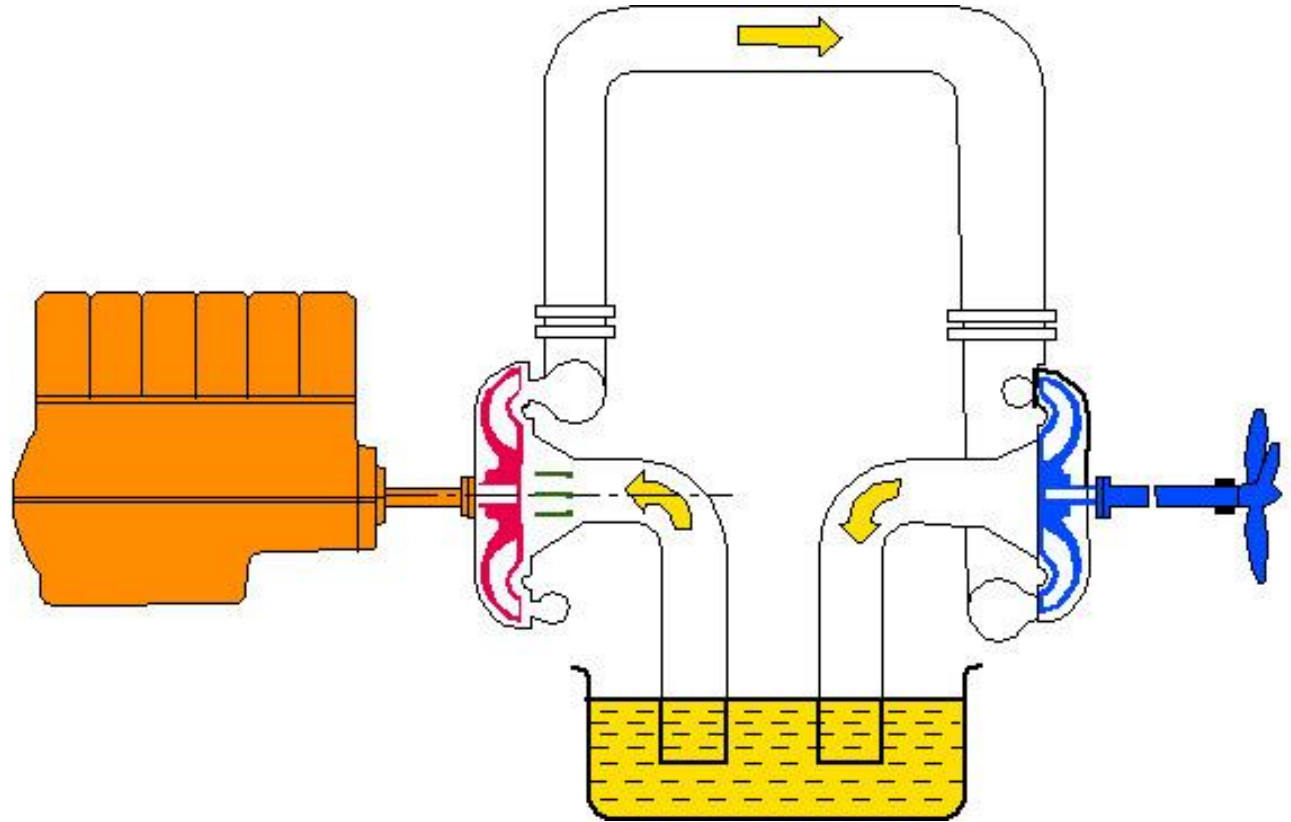



# مبدل گشتاور (Torque convertor)

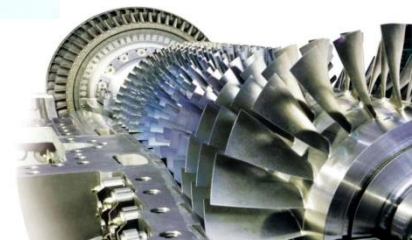
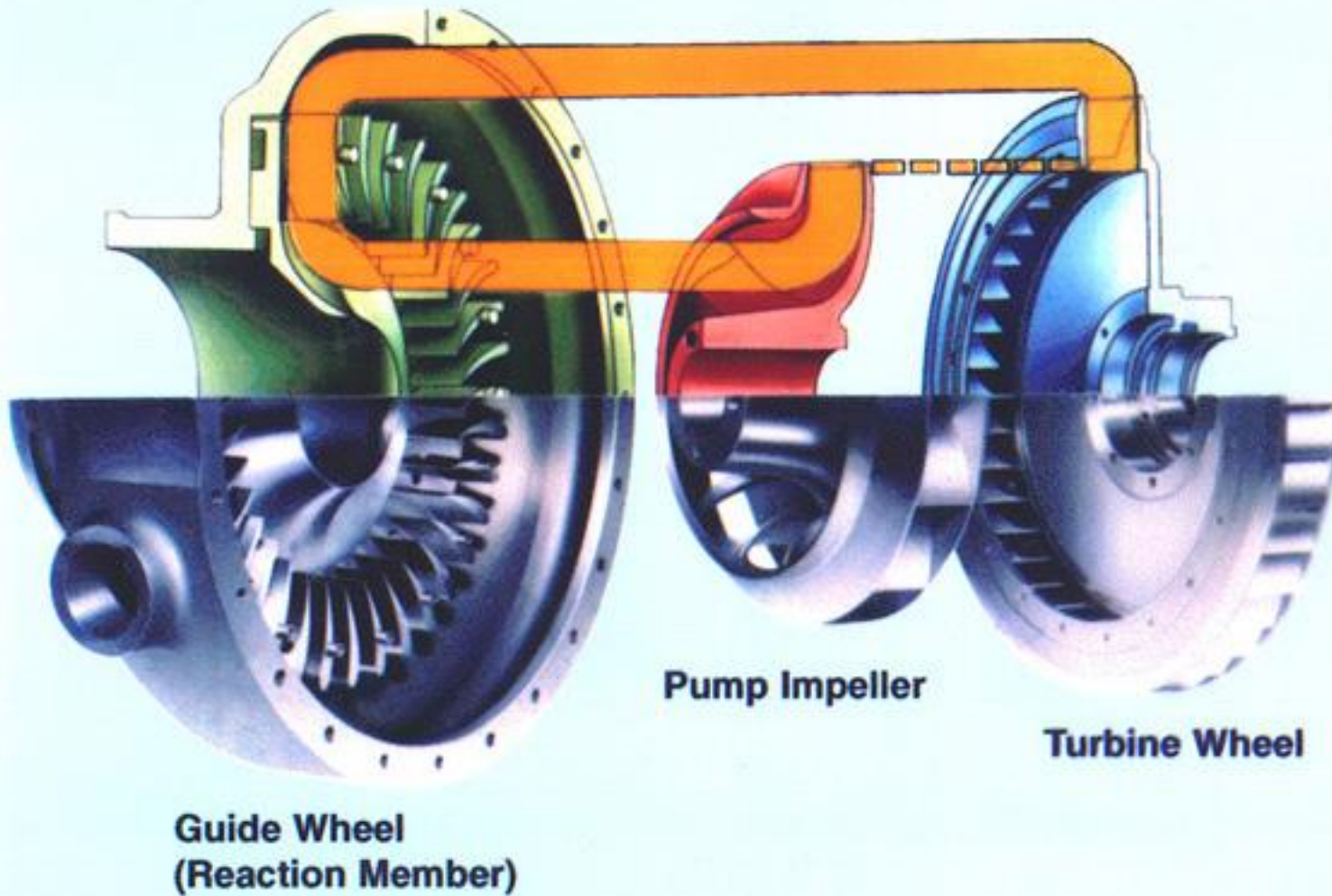

*Guide Vane Operation*

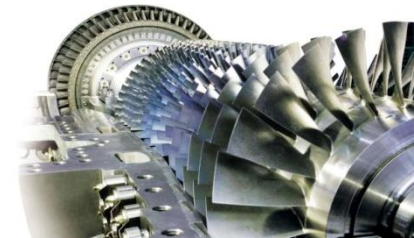
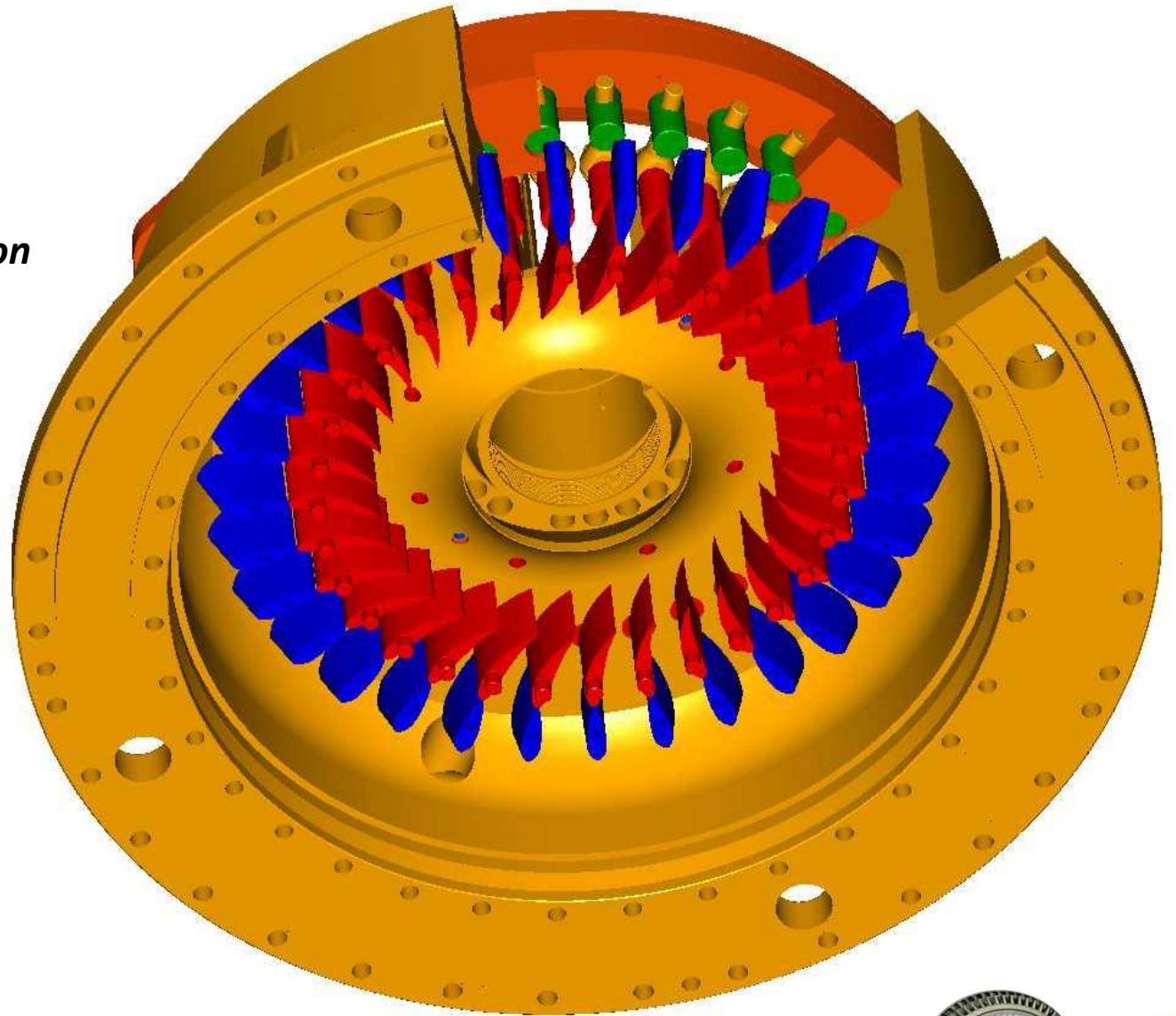



# تجهيزات راه اندازی (Starting means)



insdl.ir

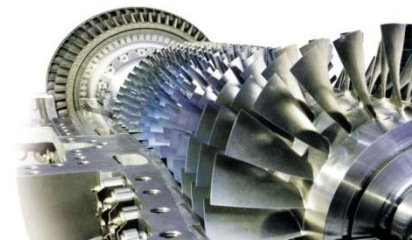

# Turbine Encl. Ventilation

**SYNONIM**

KM-153A



**MAIN**

KM-153B



**AUX**

FS-5021

FIRE DETECTION SYSTEM	
ASHH 5005/10	NORMAL
ASHH 5001/2	NORMAL
FSHH-5001/2	NORMAL
FSHH 5003/4	NORMAL
MANUAL DISCH.:	NORMAL
DISCHARGE:	DISCHARGE FAIL
STATUS:	NORMAL
CO2 BOTTLES:	#####

GAS DETECTION SYSTEM	
FILTER:	GAS TRIP
ACCESSORY:	GAS TRIP
TURBINE:	GAS TRIP

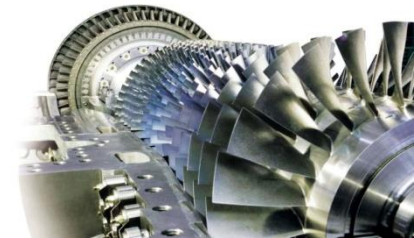
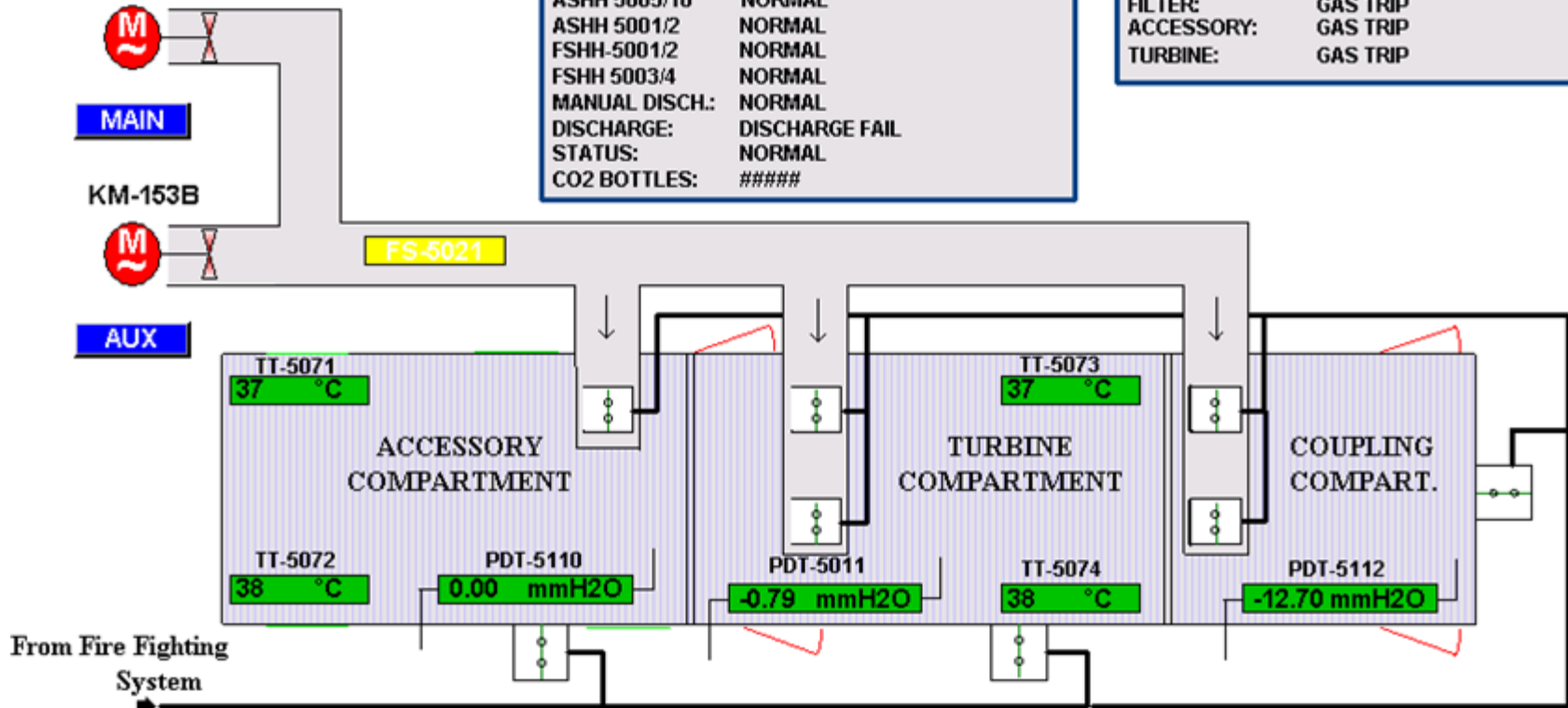



# سیستم تهویه (Ventilation system)

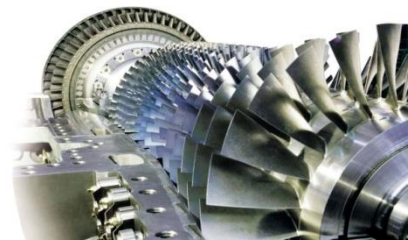

- Online washing
- Offline washing
  - Pump
  - Water Tank
  - Water and Detergent tank

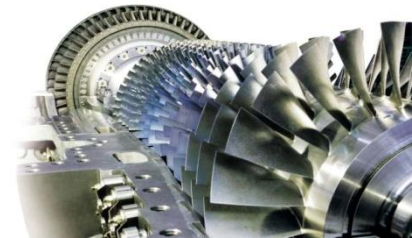



# سیستم شستشوی کمپرسور (Offline compressor washing)

## Water Wash Off-line

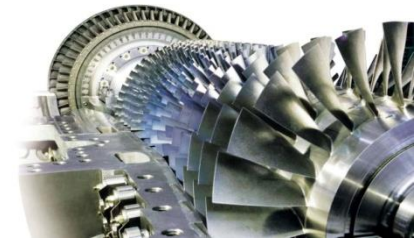
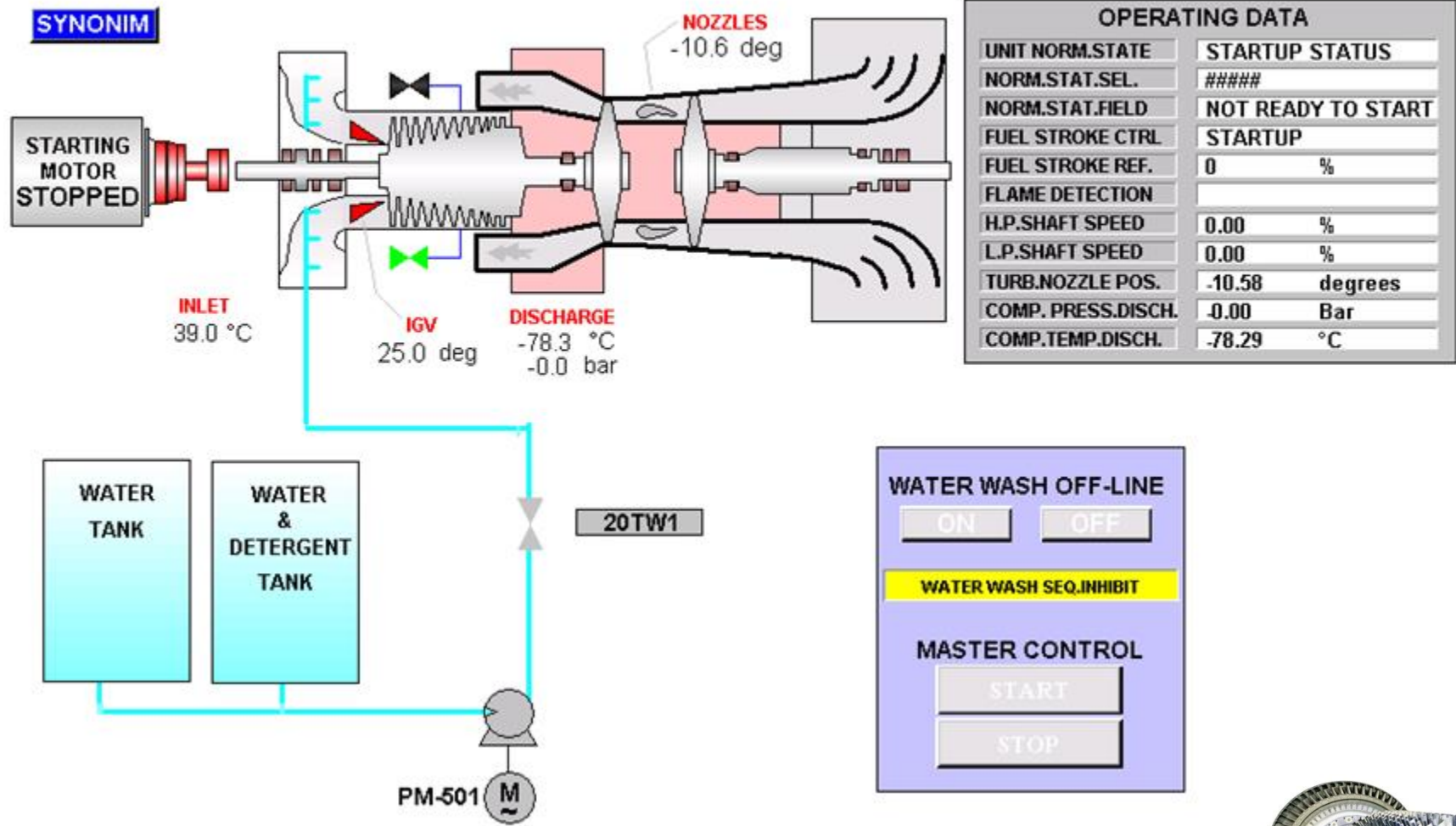

# سیستم شستشوی کمپرسور (Offline compressor washing)

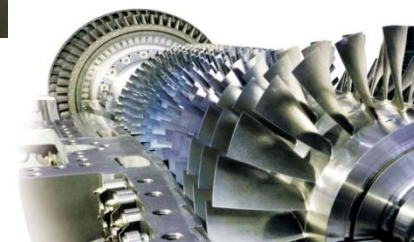



# سیستم شستشوی کمپرسور (Offline compressor washing)

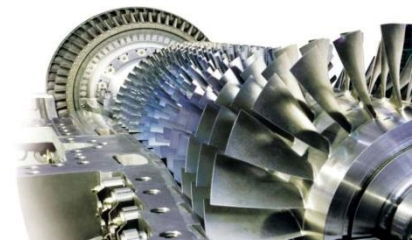

# مدار روانکاری (Lubrication)

SYNONIM

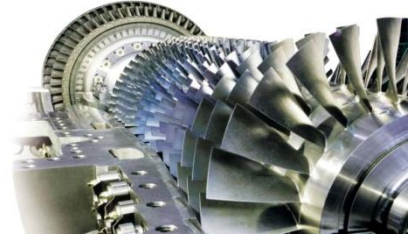
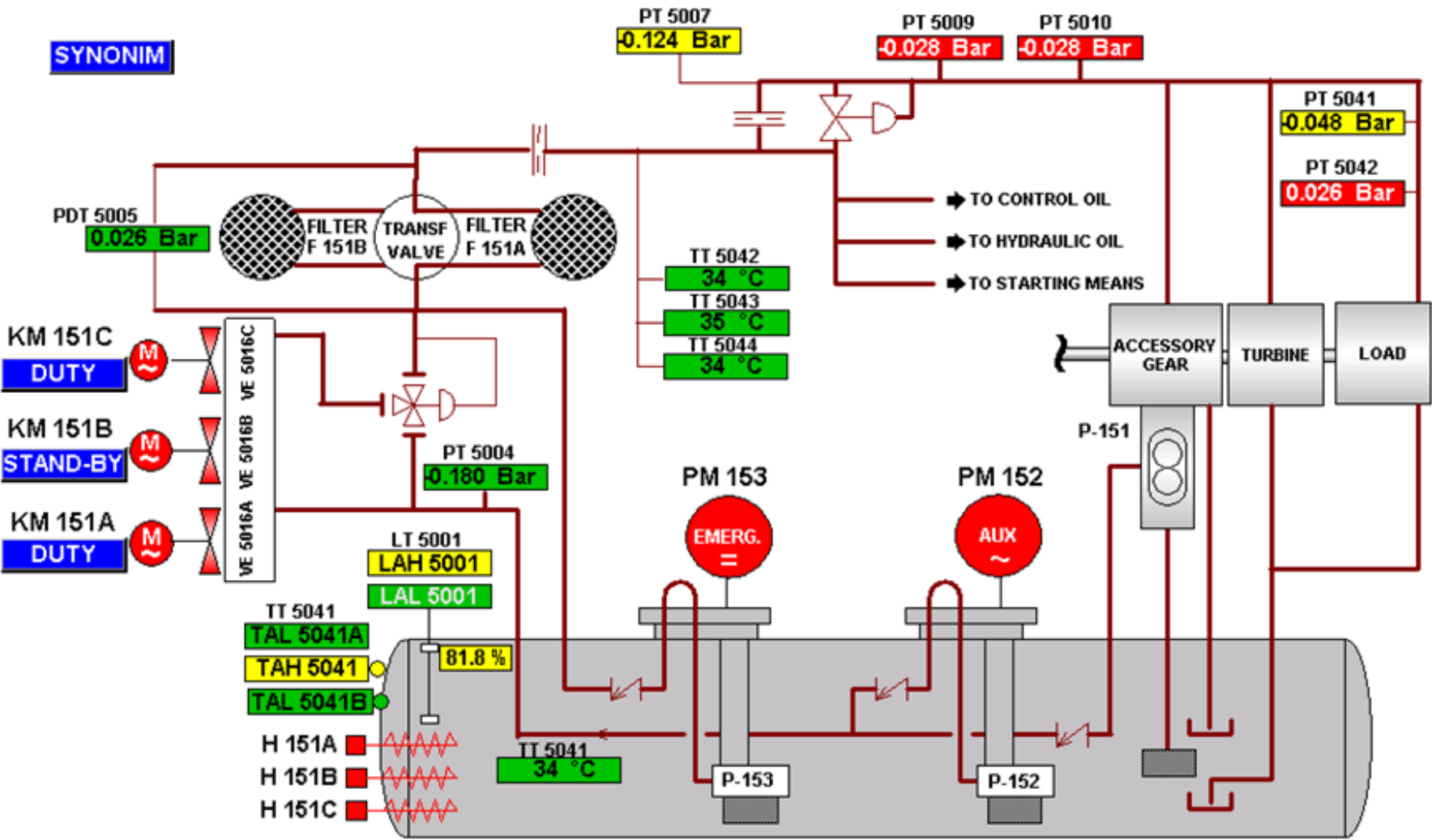



## روانکاری (Lubrication)



insdl.ir

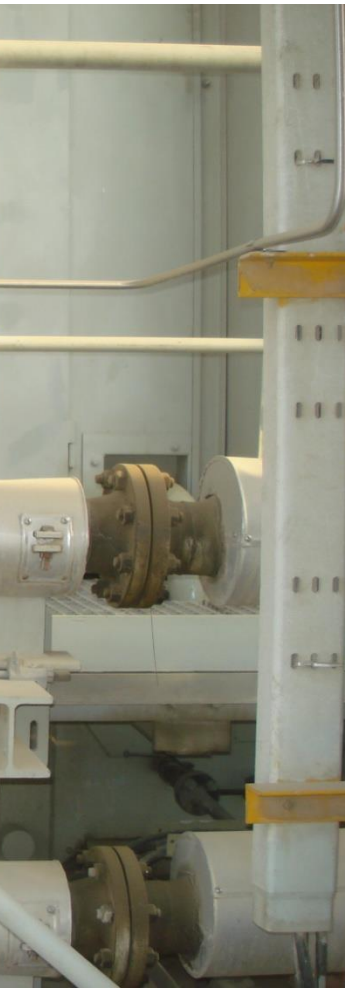

- مخزن (Reservoir)
- پمپها
- اصلی (Main)
- کمکی (Auxiliary)
- اضطراری (Emergency)
- فیلتر
- خنک کن هوایی
- شیر کنترل سه راهی دمایی (TCV)
- جدا کننده رطوبت روغن (Oil mist separator)

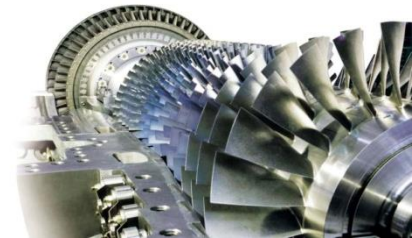

# راه اندازی توربین

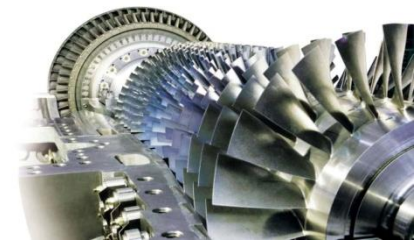
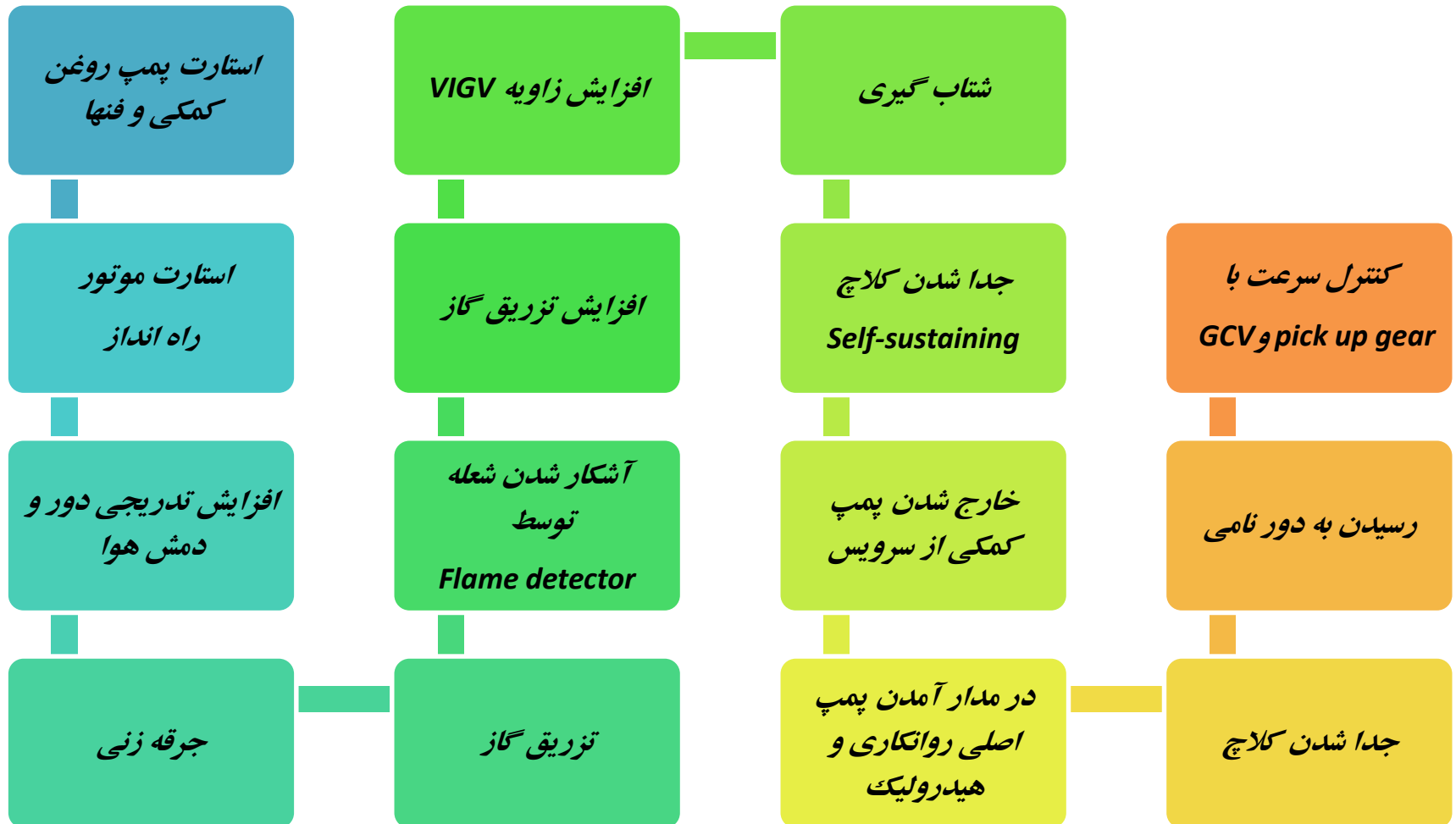



***THE END***