



Tavan Rahe Sanat
(TRS) Manufacturing Company

LV PRODUCTS:
**ELECTRICAL
CONTACTS**



Brief Introduction

Tavan Rahe Sanat (TRS) Manufacturing Company was founded in 1993 in Iran. TRS Co. has acquired the technology, technical infrastructure and state-of-the-art machinery along with its quality control test facility to manufacture products with superior quality and competitive pricing.

Today, TRS Co. is the leading manufacturer of contact rivets and contact components in the region, supplying to domestic markets as well as some other countries mainly due to its high quality products.

TRS Co. has the annual capacity to manufacture 1.5 billion pieces of electrical contact rivets which provides a very short lead production time and quick delivery to customers.



Company Facilities and Info

- Plant ground area: 5000 sqm
- Roofed area: 7000 sqm
- Head quarters in Tehran: 470 sqm
- Total number of employees: 200
- Approx. annual turnover: 20 million USD
- Modern state of the art machinery
- In-factory accredited standard laboratories
- Export to more than 10 countries





Quality Certificates

ISIRI

ISO 9001: 2008

CE

Gost-R



- Short delivery time
- Reasonable prices
- Technical support
- Ability to manufacture special and customized products based on customer requirements
- High quality raw material
- Wide range of head and shank diameters

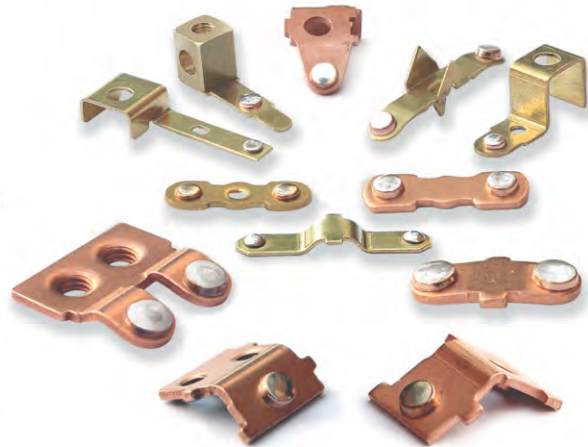

A. Solid contact rivets:

Solid contact rivets are made of one element and include:

- ▶ Silver contact rivets
- ▶ Copper contact rivets
- ▶ Aluminium contact rivets



B. Bimetal contact rivets:

B.1. DIMENSIONS

The below table shows a list of bimetal contact rivets which are frequently manufactured. We are also able to produce any solid or bimetal contact rivets according to customer's requirements. Usually head diameter of contact rivets ranges from 2.5mm to 12mm. TRS is ready to deliver your custom ordered contact rivets based on your special requirements.

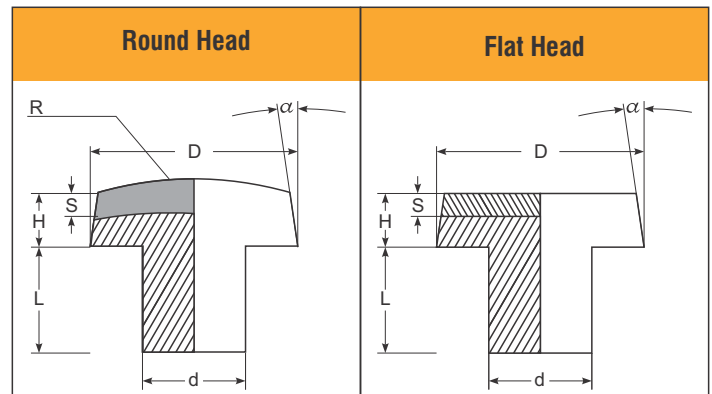

Product Dimensions

Parameter	Head Diameter	Head Thickness	Shank Diameter	Shank Length	Heading Layer Thickness	Relief Angle	Radius Of The Head	
Symbol	D	H	d	L	S	α	R	
Tolerance	± 0.1	± 0.05	± 0.05	± 0.05	± 0.05	$\pm 10\%$	$\pm 10\%$	
Part Number	CR-001	2.5	0.5-0.8	1.2-1.5	1.5	0.25-0.5	10	6
	CR-050	2.7	0.5-0.8	1.2-1.5	1.5	0.25-0.5	10	6
	CR-100	3.0	0.5-0.8	1.2-1.5	1.5-1.8-2.0	0.25-0.5	10	6
	CR-150	3.2	0.5-0.8	1.5-2.0	1.5-1.8-2.0	0.25-0.5	10	6
	CR-200	3.5	0.7-1.2	1.5-2.0	2.0-2.5	0.3-0.5	10	8
	CR-250	4.0	0.8-1.2	2.0-2.5	2.0-2.5	0.3-0.6	10	8
	CR-300	4.5	1.0-1.2	2.0-2.5	2.0-2.5	0.3-0.6	10	10
	CR-350	5.0	1.0-1.5	2.5	2.0-3.0	0.4-0.6	10	10
	CR-400	5.5	1.0-2.0	2.5-3.0	2.0-3.0	0.4-0.6	15	15
	CR-450	6.0	1.0-2.0	3.0	3.0-4.0	0.4-0.7	15	20
	CR-500	6.5	1.5-2.0	3.0-3.5	3.0-4.0	0.4-0.7	15	20
	CR-550	7.0	1.5-2.0	3.0-3.5	3.0-4.0	0.6-1.0	15	20
	CR-600	7.5	1.5-2.0	3.0-3.5	3.0-4.0	0.6-1.0	15	20
	CR-650	8.0	1.5-2.0	4.0	4.5-5.0	0.6-1.0	15	25
	CR-700	9.0	0.2	4.0	4.0-5.0	0.6-1.0	15	25
	CR-750	10.0	0.2	4.0	4.0-5.0	0.6-1.0	15	40
CR-800	11.0	0.2	4.0	4.0-5.0	0.6-1.0	15	40	
CR-850	12.0	0.2	4.0	4.0-5.0	0.6-1.0	15	40	

● All dimensions are in millimeters (mm).

● When ordering please choose the contact head shape (Flat head / Round head).

B.2. HEADING MATERIALS

Although pure silver has a higher electrical conductivity compared to its alloys, but its mechanical hardness and resistance properties are lower. To enhance electrical, mechanical and thermal characteristics of the contact headings, various Silver alloys are used. Each of these alloys has special technical characteristics which are briefly mentioned below.

1: High Purity Silver (Ag 99.99)

General Description:

Pure Silver materials show high conductivity and good resistance to high currents but have a lower lifespan time compared to silver alloys.

Applications:

Considering its properties, High purity silver is used in low power micro switches, computer parts, thermostats and etc.

2: Silver-Nickel Alloy (AgNi)

General Description:

AgNi materials have higher resistance to arc erosions and have a low tendency to sticking and welding. AgNi materials show good workability and are easy to weld to contact supports. Ductility decreases with the rise in Nickel amount. AgNi materials are also environment-protective materials.

Applications:

Any type of switchgear using current from 0.5A to 250A and voltages from 24V to 600V can use AgNi contacts. This material is ideal for moving contacts in safety devices with normal current greater than 32A. It is particularly suitable for relays and contactors operating between 0.5A and 20A.

3: Silver-Cadmium Oxide Alloy (AgCdO)

General Description:

AgCdO contacts are the most widely used contacts, in low voltage electric apparatus. They combine a satisfactory resistance against contact welding with a good arc erosion resistance and a fairly low contact resistance over their complete service life.

Applications:

Mainly used in almost every type of low voltage switching device with greater lifespan compared to AgNi. They are typically used in microswitches, relays, light switches, contactors, switches for household appliances, some types of protective switches as well as certain types of circuit breakers.

4: Silver-Tin Oxide Alloy (AgSnO₂)

General Description:

AgSnO₂ materials show high arc erosion resistance and a good resistance against contact welding. AgSnO₂ materials can be used in a manner that contact resistance over temperature can be maintained low and stable over service life.

Applications:

Mostly used in AC or DC switches with currents from 10A to 300A and voltages from 24V to 600V. AgSnO₂ materials are vastly used in contactors and AC switches with voltages higher than 50KW, Circuit breakers and electric auto parts.

Physical & Electrical characteristics of commonly used silver alloys in contacts.

Material	Alloy%	Vickers Hardness (HV)	Resistance Ratio ($\mu\Omega \cdot \text{cm}$)	Electrical Conductivity (%IACS)	Tensile Strength (MPa)	Density (gr/Cm^3)
Ag	Ag 99.99	30-70	1.8	104	320-400	10.50
AgNi	Ag 90; Ni 10	80-100	2.0	90	300-370	10.20
	Ag 85; Ni 15	85-105	2.1	85	310-370	10.10
AgCdO	Ag 90; CdO 10	70-105	2.3	85	250-350	10.00
	Ag 88; CdO 12	70-110	2.4	85	250-350	9.95
	Ag 85; CdO 15	78-118	2.5	78	250-350	9.80
	Ag 84; CdO 16	80-120	2.6	75	250-350	9.70
AgSnO ₂	Ag 92; SnO ₂ 8	70-110	2.5	87.5	230-380	9.90
	Ag 90; SnO ₂ 10	75-115	2.7	83	230-380	9.60
	Ag 88; SnO ₂ 12	80-120	2.8	78	230-380	9.50

TRS Mfg. CO. is able to supply complete fixed and moving contact blocks and contact components, with electrical contact rivets riveted on them, ready to be used in the given switch or device.

Our main advantages in supplying these complete contact components to our clients are:

- ▶ Production of contact rivets, with high precision and at the highest standards
- ▶ Having an in-house die and mold production dept. with special expertise in production of progressive matrix molds
- ▶ Taking advantage of high speed CNC machines
- ▶ Riveting operation via advanced automatic riveting machines
- ▶ Having access to the best quality raw materials
- ▶ Our in-house coating dept. is expert in various Cu/Zn/Ag coatings

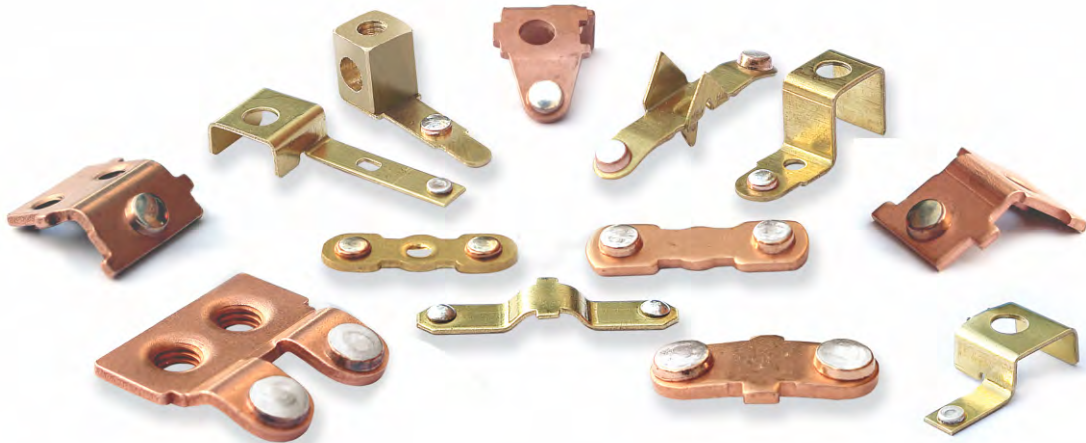

TRS Mfg. Co. maintains quality not only by passing quality certificates but also through its accredited standard laboratory located on factory site. TRS Mfg Co.'s laboratory is a licensed test lab acknowledged by Iran National Standards Organization and issues official technical quality test reports on request.

A few test equipment at TRS Mfg. Co. test laboratory are mentioned below.

- ▶ Digital Image Mapper
- ▶ Micro hardness tester
- ▶ Profile Projector
- ▶ Metallographic Microscope
- ▶ Computer controlled Tensile strength meter
- ▶ Especially designed testing system to test contacts under nominal voltage, variable current and power factor according to IEC947-1,2
- ▶ Especially designed testing system to test contact's life
- ▶ Couloscope
- ▶ High precision digital micro Ohm tester
- ▶ Salt spray tester
- ▶ and many other standard testing equipment

Profile Projector



Metallographic Microscope



Digital Image Mapper



Micro Hardness Tester

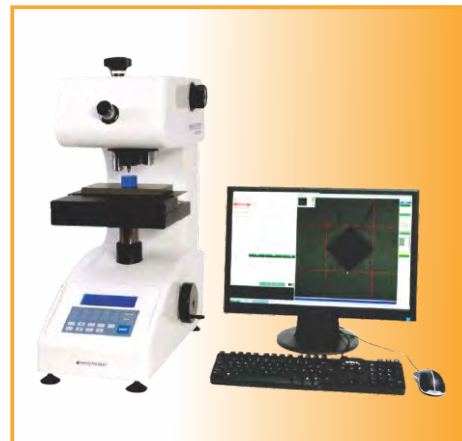



📍 Head Office: 3rd Fl., No. 22, 10th St., Bucharest St., Tehran, Iran

☎ Tel: +9821-88504490 📠 Fax: +9821-88733048 🌐 www.trse.co.ir ✉ export@trselectrical.com