

User Guide & Tutorials

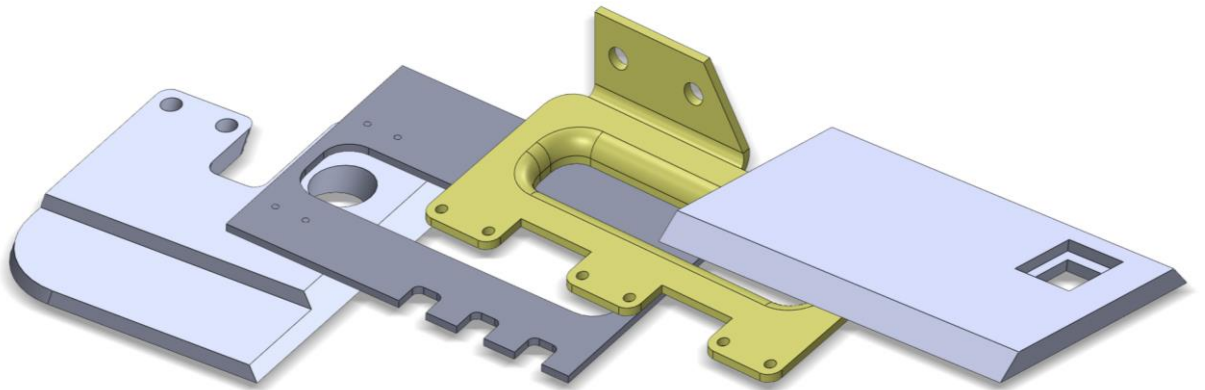

Disclaimer

Geometric Americas Inc. makes no warranties, either expressed or implied with respect to this manual. Geometric Americas Inc. reserves the right to revise and improve products as it sees fit, and to revise the specifications and information contained herein without prior notice. Due to continuing product development, specifications and capabilities described in this manual are subject to change without notice.

Trademarks

The following and other product names and corporate references herein are registered or proprietary trademarks of their respective owners.

NESTINGWorks® is a registered trademark of Geometric Americas Inc.

SOLIDWORKS® is a registered trademark of Dassault Systèmes SOLIDWORKS Corp.

Microsoft®, Windows® and Access® are registered trademarks of Microsoft Corporation in the United States and/or other countries.

All other brands and names are the property of their respective owners.

Copyright © 2018 Geometric Americas, Inc.
All Rights Reserved.



Geometric

An HCL Technologies Company

Product Name:
Version:

NESTINGWorks
2019 SP0



TABLE OF CONTENTS

NESTINGWORKS: INTRODUCTION	9
What is NESTINGWorks?	9
Procuring NESTINGWorks	9
Why NESTINGWorks should be your preferred nesting program	9
Receiving latest updates & Update Support Plan (USP)	10
Technical Support	10
NESTINGWorks Installation Guide & License Activation Guide	11
NESTINGWorks Tutorials	11
ABOUT THESE TUTORIALS	12
UNDERSTANDING THE NESTINGWORKS FUNDAMENTALS	15
Basic Procedure of Nesting	15
Flowchart on Basic Procedure to Implement Nesting	21
The Part Model/Assembly	23
Defining Part Parameters	24
The Part data Tab	25
Part List	26
Thickness	27
Quantity	27
Grain Direction	28
Material	30
Normal Face	31
Reverse Direction of Normal Face	32
Rotation Angle	34
Defining Sheet Parameters	35
The Sheet data Tab	35
Sheet List	36
Thickness	37
Quantity	37
Material	37
Grain Direction	37
Sheet Type	38
Add Sheet & Remove Sheet buttons	41
Defining Multi Head Options Parameters	42
How the functionality of nesting with multiple tool heads works	42
The Default Settings in the Multi Head Options tab	43
Enabling Multi Tool Head Machining	44
Parameters and Data fields in the Multi Head Options tab	44
Editing the default settings for the Multi Head Options tab	47



Define Nesting Data Parameters	47
The Options Tab	47
Previewing the Nested Layout	51
Generating the Nested Layout	51
How the Nested layouts generated are saved within SOLIDWORKS	51
TUTORIAL 1 - NESTING AN ASSEMBLY	53
Step 1: Open the Assembly	53
Step 2: Assign Nesting Parameters	53
Part Data Tab	55
Sheet Data Tab	56
Options tab	57
Step 3: Generating the Nested Layout	59
Summary Text	59
Nested Assembly	60
TUTORIAL 2- SINGLE PART, SINGLE SHEET NESTING FOR A SOLID PART	63
Introduction	63
STEP 1: Open the Part	63
STEP 2: Define the Part Parameters	64
STEP 3: Define the Sheet Parameters & adding a standard sheet	66
STEP 4: Selecting a machine with Single Tool Head for the Nesting Process	67
STEP 5: Define Nesting Parameters	68
STEP 6: Generating the Nested Layout	69
Result A	70
Result B	71
Result C	72
TUTORIAL 3 – SINGLE PART, SINGLE SHEET NESTING FOR SHEET METAL PART	74
Introduction	74
STEP 1: Open the Part	74
STEP 2: Change in Configuration File settings	75
Enabling the option to Flatten Sheet Metal Part	75
Enabling the Fix Component Feature of SOLIDWORKS	75
STEP 3: Define the Part Parameters	75
STEP 4: Defining a ‘Custom’ size sheet	77
STEP 5: Selecting a machine with Single Tool Head for the Nesting Process	77
STEP 6: Define Nesting Parameters and Generating Layout	78
TUTORIAL 4 – NESTING OF MULTIPLE PARTS BASED ON THICKNESS	83
Introduction	83



STEP 1: Using ‘Nest by Folder’ to open the Assembly	83
STEP 2: Define the Part Parameters	84
Selectively Nesting Parts	85
STEP 3: Adding a sheet of using ‘DXF’ file.	87
STEP 4: Selecting a machine with Single Tool Head for the Nesting Process	88
STEP 5: Define Nesting Parameters	89
STEP 6: Nesting all the Parts in the Assembly	89
Adding a standard sheet	91
STEP 7: Defining the Nesting Parameters	92
Nesting of multi-body parts	94
Steps to nest a Multi-body Part	94
Nesting of assemblies containing multi-body parts	95
Steps to nest an Assembly containing Multi-body Parts	95
TUTORIAL 5 – NEST BY MATERIAL, NEST BY THICKNESS	97
Introduction	97
Preferential Hole Filling	97
STEP 1: Enabling ‘Preferential Hole Filling’ functionality	97
STEP 2: Using ‘Nest by Folder’ to open the Assembly	97
STEP 3: Define the Part Parameters	98
Thickness & Material of the parts	98
Step Angle & Quantity	99
Normal Face	100
Grain Direction	100
STEP 4: Defining Sheet Parameters	100
Adding Standard Sheet	101
Adding Standard Sheet 2	101
STEP 5: Selecting a machine with Single Tool Head for the Nesting Process	102
STEP 6: Define Nesting Parameters	102
STEP 7: Generating the Nested Layout	103
Saving Files in the .dxf format	103
Summary File	103
Viewing the Nested Layouts	105
TUTORIAL 6 – NESTING WITH MULTIPLE TOOL HEADS	107
Introduction	107
STEP 1: Open the Assembly	107
STEP 2: Enabling the option of flattening the sheet metal parts	108
STEP 3: Define the Part Parameters	108
STEP 4: Define the Sheet Parameters	109
STEP 5: Define the Multi head options parameters	110
STEP 6: Define Nesting Parameters	112



STEP 7: Generating the Nested Layout	113
TUTORIAL 7 – NESTING IMPORTED SHEET METAL COMPONENTS WITH BENDS	115
Introduction	115
The functionality of Unfolding Sheet Metal Parts	115
The ‘Unfold Imported Bodies’ dialog box	115
Commands to Invoke ‘Unfold Imported Bodies’ dialog box	116
1. The ‘Enable Auto Unfold’ Option	116
2. The ‘Intelligent Unfold’ Command	117
3. The ‘Unfold All Parts’ Command	118
STEP 1: Open the Assembly	119
STEP 2: Unfolding the Parts with bends	120
STEP 3: Defining the Part, Sheet & Nesting Parameters	123
Part Data Tab	123
Sheet Data Tab	123
Assigning Nesting Parameters in ‘Options’ tab	124
STEP 4: Generating the Nested Layout	124
TUTORIAL 8 – UNFOLDING IMPORTED 3D SHEET METAL COMPONENTS WITH FAULTY SURFACES	127
Introduction	127
STEP 1: Open the Assembly	127
STEP 2: Executing the ‘Intelligent Unfold’ command	128
STEP 3: Selective unfolding of imported parts	128
STEP 4: Executing the Nesting Job	134
Part Data Tab	134
Sheet Data Tab	135
Nesting Parameters	136
STEP 5: Generating the Nested Layout	136
TUTORIAL 9 – ASSIGNING ASSEMBLY QUANTITIES	138
Introduction	138
STEP 1: Open the Assembly	138
Components of the Parent Assembly	139
STEP 2: Enabling the option of flattening the sheet metal parts	141
STEP 3: Enabling the feature for Assigning Assembly Quantities	142
STEP 4: Execute the ‘Create Nest Job’ command	142
Assembly Column	143
Part name column	144
Quantity Column	144
STEP 5: Changing the quantity of the Parent assembly	145



Analysis	145
STEP 6: Changing the Quantity of a sub-assembly	146
Analysis	147
STEP 7: Changing the Quantity of Parent Assembly	148
STEP 8: Overwriting automatically assigned Quantity values for Parts with user-defined values	149
STEP 9: Deactivating the feature of assigning assembly quantities	149
Deactivating the feature only for the current nesting job	150
Deactivating the feature for all nesting jobs	150
TUTORIAL 10 – UNFOLDING SHEET METAL COMPONENTS USING ‘INTERACTIVE UNFOLD’ COMMAND	151
Introduction	151
The ‘Interactive Unfold’ Command	151
Difference between the various Unfold commands	151
The ‘Chain Faces’ option for Unfold commands	152
STEP 1: Open the Assembly	152
STEP 2: Executing the ‘Interactive Unfold’ command	153
STEP 3: Selective Unfolding of Parts when ‘Chain Faces’ option is enabled	154
Deselecting/ Selecting the faces to be unfolded	155
Changing the Reference Face	159
STEP 4: Selective Unfolding of Parts when ‘Chain Faces’ option is disabled	160
Disabling the Chain Faces option	160
Selecting faces to unfold when Chain Faces option is disabled	161
Changing Reference face when Chain Faces option is disabled	162
TUTORIAL 11 – THE STAMP FEATURE UNFOLD OPTION	166
Introduction	166
Part 1: Stamp Feature Unfold Options for Native Sheet Metal Parts	167
STEP 1: Open the Part	167
STEP 2: Executing the Unfold Command	168
STEP 3: Retaining the stamp feature	169
STEP 4: Patching the stamp feature	169
STEP 5: Ignoring the stamp feature	170
STEP 6: Behavior in native parts without bends	171
Part 2: Stamp Feature Unfold Option for Imported Sheet Metal Parts	172
STEP 1: Open the Part	172
STEP 2: Executing the Unfold Command	172
STEP 3: Retaining the stamp feature	173
STEP 4: Patching the stamp feature	173
STEP 5: Ignoring the stamp feature	174
STEP 6: Behavior in imported parts without bends	175



TUTORIAL 12 – GENERATING NC CODES FOR NESTED LAYOUTS USING CAMWORKS (I)	176
How the Nested layouts generated are saved within SOLIDWORKS	176
Relation between NESTINGWorks and CAMWorks	176
Steps to generate NC codes for Nested layouts	177
Generating the nested layout assembly	178
Step 1: Define the Fixture Coordinates	179
Steps to set the Fixture Coordinates System	179
Step 2: Define the Machine	180
Step 3: Addition of nested Parts to Part Manager	185
Step 4: Define the Stock	186
Step 5: Defining Machinable Features	187
Extracting Machinable Feature using AFR	187
Interactively Inserting Features	188
Step 6: Sorting Part Instances	189
Step 7: Generating the Operation Plan	191
Step 8: Adjusting Operation Parameters	192
Step 9: Defining G-code Program Zero Location	193
Step 10: Generating Toolpaths and Sorting Operations	195
Step 11: Simulate Toolpaths	198
Step 12: Post Processing Toolpaths	199
TUTORIAL 13 – GENERATING NC CODES FOR NESTED LAYOUTS USING CAMWORKS (II)	201
Functionality to link NESTINGWorks with CAMWorks	201
Advantages of this functionality	201
Enabling the functionality	201
How the functionality works	202
Tutorial illustrating Generation of NC codes for Nested Layouts	203
Section I: Generating Nested layouts	203
Section II: Generating NC codes using CAMWorks	206



NESTINGWORKS: INTRODUCTION

What is NESTINGWorks?

NESTINGWorks, developed by **Geometric Americas, Inc.**, is an automatic, true-shape nesting program that easily creates fast and efficient nested layouts. It is seamlessly integrated within SOLIDWORKS® and allows nesting of flat or 3D solid or sheet metal parts and assemblies.

NESTINGWorks can be used to create efficient layouts of metal, wood or composite based materials, producing the maximum number of parts from a single piece of raw material within minutes.

Procuring NESTINGWorks

Geometric Americas, Inc. sells *NESTINGWorks* and related program modules through a worldwide network of **Value Added Resellers**.

- If you are an **existing user** of our other product of *Geometric Americas, Inc.*, you can contact your Reseller for *NESTINGWorks*.
- If you are a **first-time user** of *NESTINGWorks*, you can find your local Reseller on www.camworks.com.

Note: *NESTINGWorks* can be purchased only through Resellers. Though the *NESTINGWorks* installer can be downloaded from the website, the license required to run the *NESTINGWorks* application can be purchased only from an authorized Reseller.

Why NESTINGWorks should be your preferred nesting program

NESTINGWorks has the following advantages that make it the ideal choice when it comes to choosing the nesting application to suit your needs:

- **Ease of Use:**
Parts imported from other CAD applications or created in SOLIDWORKS as well as assemblies can be directly used as an input without the need to convert them to flat patterns.
- **Full Associativity with SOLIDWORKS:**
Updates are tracked and flagged whenever the component is changed. Refresh rebuild the nest to reflect the updated designs.
- **SOLIDWORKS Compatible Output:**
Provides the nested output as a new SOLIDWORKS assembly and retains the original part and assembly model files. The SOLIDWORKS nested assembly can then be used for further processing, such as toolpath and NC Code generation with any CAM software, if required.
- **Part Requirements automatically assigned:**
Automatically nests multiple parts, based on material and thickness, within an assembly in a single run.



This feature helps users eliminate manual efforts in segregating individual parts with the same material and thickness for a nesting operation.

- **Material Optimization:**

The advanced true-shape automatic nesting algorithms reduce raw material consumption by providing optimized and compact layouts.

- **Nesting with multiple tool heads:**

An optional feature to nest two or more identical nesting layouts using multiple tool heads is provided. This feature is useful for flame cutting applications.

- **Save Nested layout Output as DXF file:**

An optional feature that allows users to save the nested layouts in the internationally accepted CAD data file format known as 'Drawing Exchange Format' (.dxf), in addition to the existing assembly file format (.sldasm).

- **Unfold Imported Sheet Metal Bodies:**

Supports nesting of imported sheet metal part models containing bends. Using this 'Unfold Imported Bodies' dialog box, such sheet metal parts can be unfolded before executing the nesting job.

Receiving latest updates & Update Support Plan (USP)

When you purchase *NESTINGWorks* through a Reseller, you will receive a permanent license required to run the *NESTINGWorks* application. In addition to this, you will also be enrolled in a *NESTINGWorks Update Support Plan (USP)* for a specific duration. Your Reseller will brief you about the USP when you purchase *NESTINGWorks*.

Being enrolled in the *NESTINGWorks Update Support Plan* has the following benefits:

- **Receiving updates:** It allows you to keep your *NESTINGWorks* application up-to-date with the new features and performance improvements of *NESTINGWorks* released in the form of Service Packs.
- **Technical Support:** You receive technical support for all your queries and doubts regarding *NESTINGWorks*.

Once your USP expires, you will no longer receive updates or support. Ensure that you repurchase an appropriate Update Support Plan from your Reseller to continue receiving technical support and updates.

Note: The *NESTINGWorks* license you purchase from your Reseller will be perpetual in nature. However, the Update Support Plan has a fixed duration. You need to repurchase an Update Support Plan after your current plan expires.

Technical Support

This manual has been designed to be as informative as possible. In case you still face problems related to installation, license activation or using *NESTINGWorks*, you can contact your local reseller.



NESTINGWorks Installation Guide & License Activation Guide

Two separate manuals has been provided to acquaint you with the details of installation and License activation for *NESTINGWorks*.

The manuals in PDF format are available in the NESTINGWorks Installer Package that you download from the website.

After you install *NESTINGWorks*, these manuals can be accessed from the Windows **Start** menu by navigating as follows:

- **Start>>All Programs>>NESTINGWorks 2019x64>>Installation Guide**
- **Start>>All Programs>>NESTINGWorks 2019x64>>License Activation Guide**

NESTINGWorks Tutorials

The last section of this manual contains illustrated tutorials which will help you understand all the aspects of using *NESTINGWorks* for practical purposes. Refer: [NESTINGWorks Tutorials](#) section.



ABOUT THESE TUTORIALS

Section 1: The first section '[Understanding the NESTINGWorks Fundamentals](#)' introduces the *NESTINGWorks* User Interface, working environment and the various Nesting parameters.

Section 2: An understanding of these basic elements is required before proceeding to the tutorials. The following tutorials given in this document will help you to learn how to use *NESTINGWorks* through a step by step hands-on tour of its features and functions. The tutorials are presented in order of increasing complexity, each building upon the knowledge gained from the previous tutorial.

Sr. No.	Tutorial	Topic covered in the Tutorial
1.	Tutorial 1 – Assembly Nesting	Nesting a Sheet Metal assembly.
2.	Tutorial 2 – Single part, Single sheet Nesting	Nesting a Solid part.
3.	Tutorial 3 – Single Part, Single sheet Nesting	Nesting a Sheet Metal Part.
4.	Tutorial 4 – Nesting by Thickness	Nesting Parts of different thickness.
5.	Tutorial 5 – Nest by material, Nest by Thickness	Nesting Parts of different material & thickness.
6.	Tutorial 6 – Nesting with Multiple tool heads	Nesting Parts of identical material and thickness intended to be machined using a Machine with Multiple Tool Heads.
7.	Tutorial 7 – Nesting of Imported Sheet Metal Parts	Nesting of Imported sheet metal parts with bends.
8.	Tutorial 8 – Nesting of Imported Sheet Metal Parts with faulty surfaces	Nesting of Imported sheet metal parts.
9.	Tutorial 9 – Assigning Assembly Quantities	Nesting an Assembly comprising sub-assemblies and parts.
10.	Tutorial 10 – Unfolding Sheet Metal Components Using 'Interactive Unfold' Command	Using 'Interactive Unfold' command to unfold sheet metal parts.



Sr. No.	Tutorial	Topic covered in the Tutorial
11.	Tutorial 11 – The Stamp Feature Unfold Option	Using ‘Stamp Feature Unfold’ Command.
12.	Tutorial 12 – Generating NC Codes For Nested Layouts Using CAMWorks(I)	Generating NC Codes For Nested Layouts Using CAMWorks
13.	Tutorial 13 – Generating NC Codes For Nested Layouts Using CAMWorks (II)	Generating NC Codes For Nested Layouts Using CAMWorks

Additional information is available in the **NESTINGWorks Context Based Help**. It is highly recommended that you read these tutorials to gain a deeper and practical understanding of *NESTINGWorks* features and capabilities.

SECTION ONE
NESTINGWorks
Fundamentals



UNDERSTANDING THE NESTINGWORKS FUNDAMENTALS

Basic Procedure of Nesting

Follow these general procedures to generate nested layouts using *NESTINGWorks*.

1. Open *SOLIDWORKS*.
2. Click on the dropdown button of the *Options* in the menu bar and select *Add-Ins*.

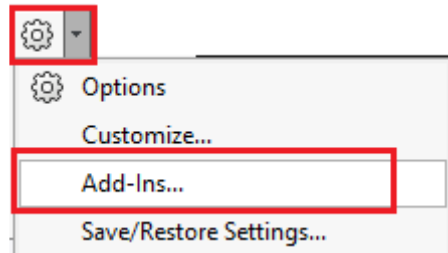

Selecting Add-Ins

3. Load the *NESTINGWorks* Add-In in the dialog box.

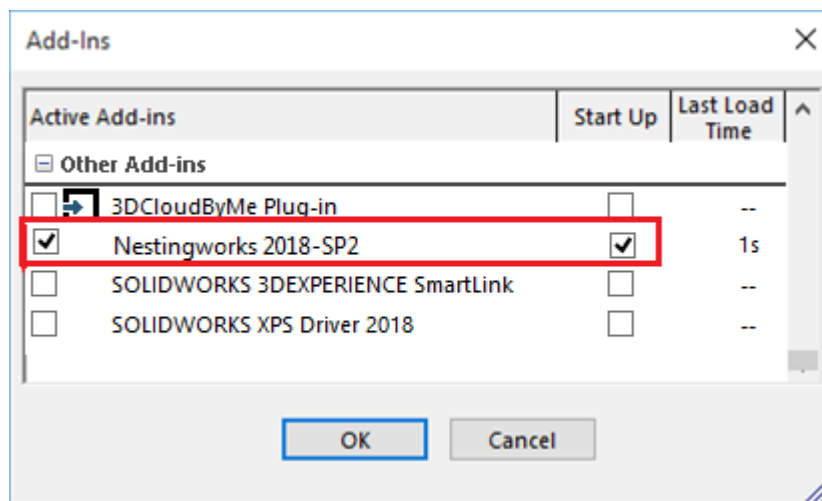

Selecting the NESTINGWorks Add-In

4. The *NESTINGWorks* menu will be added to the *SOLIDWORKS* menu bar.
5. For **Single-part nesting**:
 - i. Model or open a sheet metal part/solid part model in *SOLIDWORKS*.
For example, open the part **Tutorial_1a** located in the following folder.
C:\ProgramData\NESTINGWorksData\NESTINGWorks 201Xx64\Examples\
Tutorials\Assemblies\Tutorial1

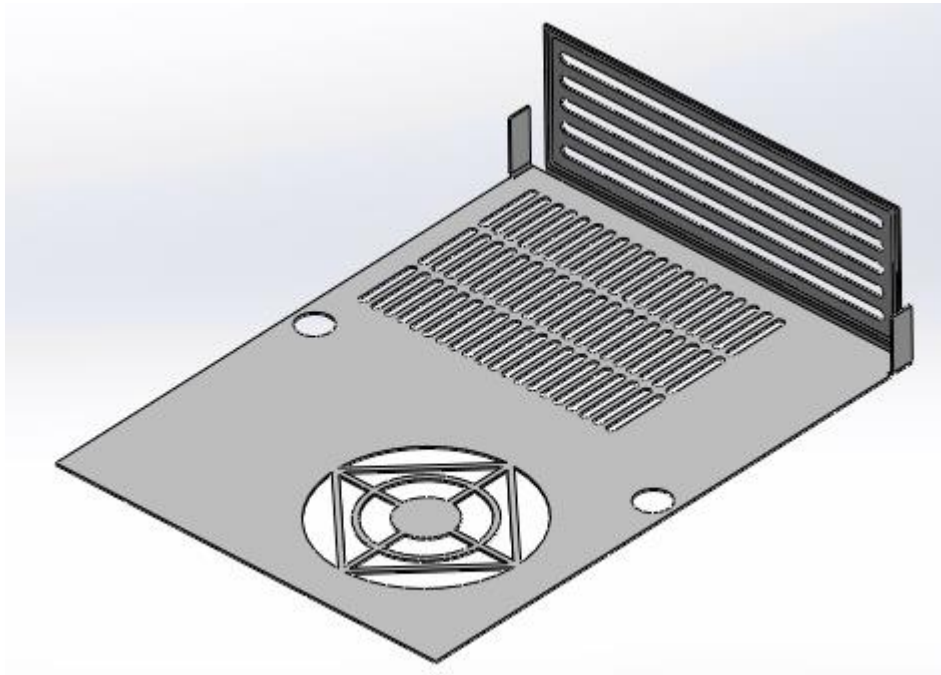

Tutorial_1a.sldprt

- ii. Select *Create Nest Job* from the NESTINGWorks Ribbon bar.

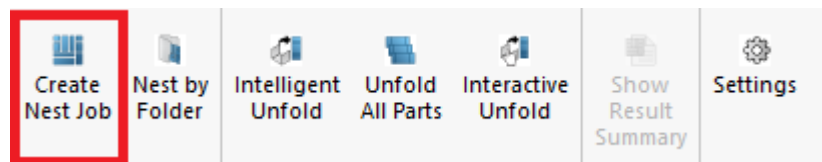

NESTINGWorks Ribbon Bar

OR

Click on the *Tool* menu and select NESTINGWorks menu in the dropdown list. Select *Create Nest Job* button from the cascading menu.

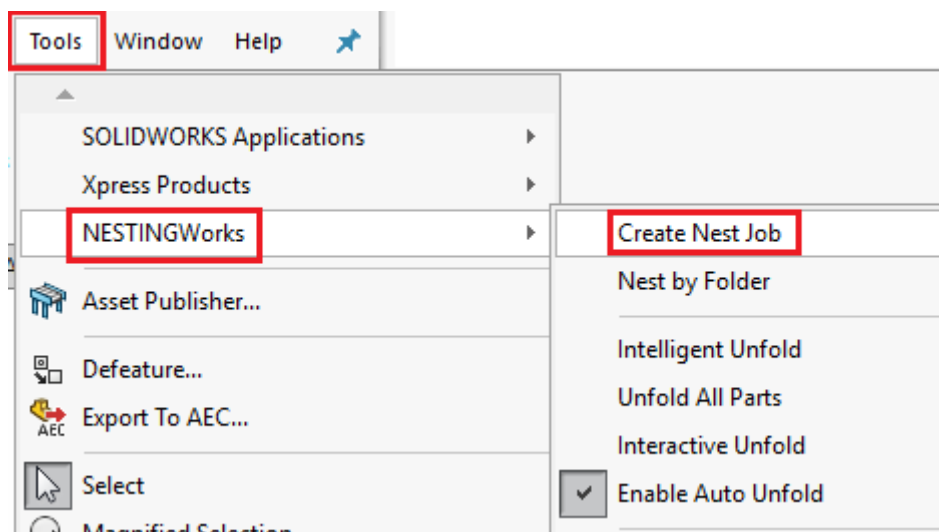

NESTINGWorks Cascading Menu



The *Create Nesting Job* dialog box is displayed.

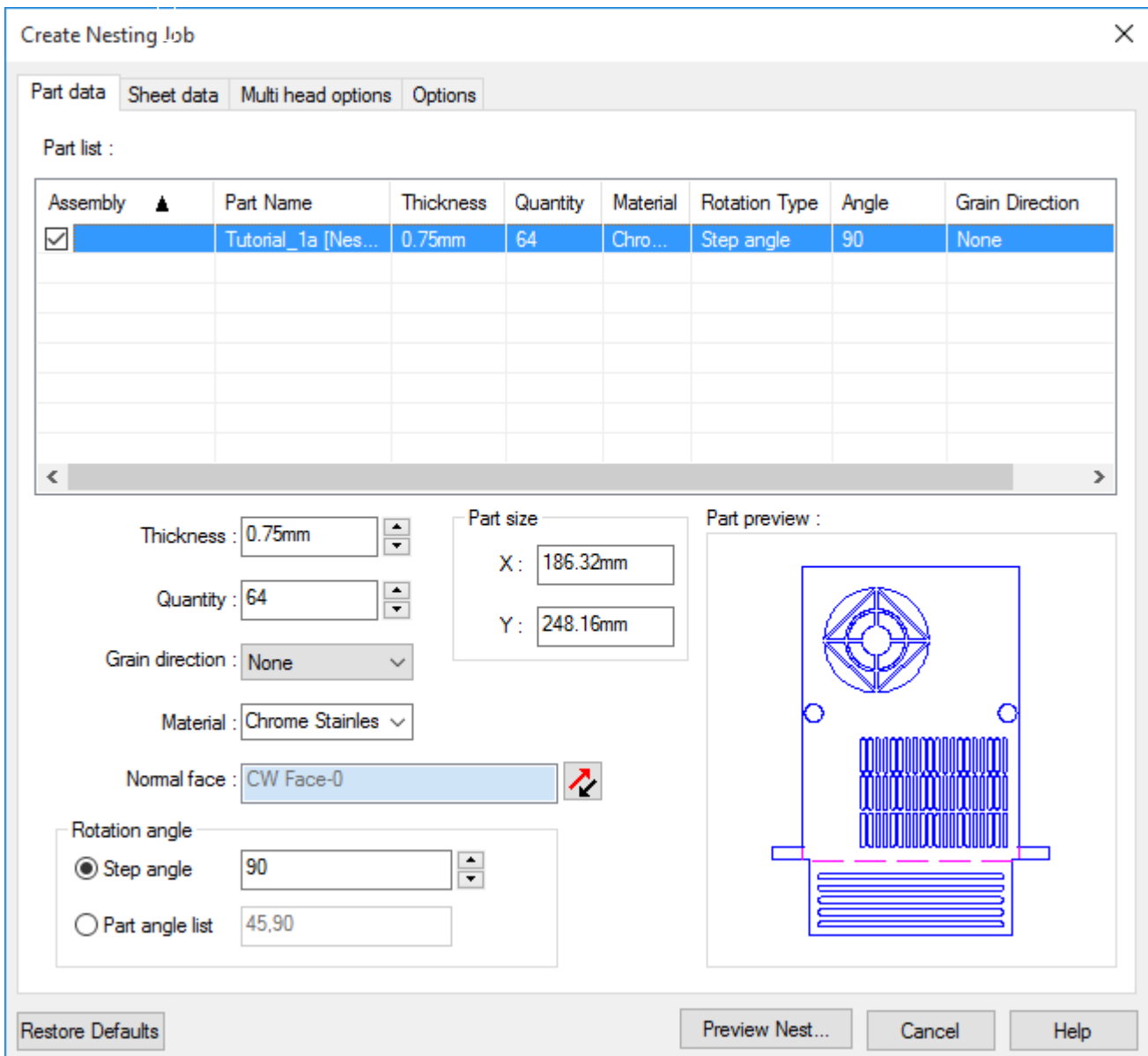

Create Nesting Job dialog box

6. For **Assembly Nesting**:

- i. Model or open a sheet metal/solid part/solid assembly in SOLIDWORKS.
- ii. Select *Create Nesting Job* from the NESTINGWorks Ribbon bar.
The *Create Nesting Job* dialog box is displayed.

7. For **Multi-part Nesting → Use Nest by Folder**

- i. If an assembly model is not available already and if the parts to be nested are available in a folder then select *Nest by Folder* from the NESTINGWorks cascading menu.
- ii. Browse to the folder containing the parts to be nested. Click *OK*.



- iii. The parts to be nested will be displayed in the SOLIDWORKS Graphical User Interface.

The *Create Nesting Job* dialog box is displayed. All the parts are listed under the *Part Data* tab of this dialog box along with the part parameters.

8. In all the three cases viz. *Single Part Nesting*, *Assembly Nesting* and *Multi-part Nesting*, if the part or assembly contains an imported sheet metal part with bends, then the ***Unfold Imported Bodies*** dialog box will be displayed prior to the *Create Nesting Job* dialog box. Use this dialog box to select the imported sheet metal parts to be unfolded and to assign parameters related to unfolding.

Once you make the required selection and assign parameters, click *OK*. The *Create Nesting Job* dialog box will be displayed.

9. In the *Create Nesting Job* dialog box, under the *Part Data* tab, modify or assign the Part controller parameters for the part(s) as required. These parameters include *Thickness*, *Material*, *Grain direction*, *Quantity*, *Rotation angle*, *Normal Face* selection as required.

These parameters are discussed in detail in the section [Part Parameters](#).

10. Under the *Sheet data* tab, select the required sheet size(s). Modify or assign the sheet parameters such as *Sheet name*, *Sheet thickness*, *Sheet material*, *Sheet quantity*, *Grain direction*, *Sheet size*, *Assembly Template*.

These parameters are discussed in detail in the section [Sheet Parameters](#).

11. If you wish to nest the part(s)/assembly using multiple tool heads, use the *Multi head options* tab to assign the associated parameters such as the *Machine name*, *Number of tool heads* (to be used), *Rail direction*, *Tool head distance* and *Multi-tool head nesting type*.

These parameters are discussed in detail in the section [Multi Head Options parameters](#).

12. Under the *Options* tab:

- i. Assign appropriate values to the parameters of *Part-to-Part distance* and *Part-to-Sheet distance*.
- ii. NESTINGWorks always saves the nested layouts generated after the execution of a nesting job in the assembly file format (*.sldasm). To optionally save the nested layouts in the .dxf format, check the *Save output as dxf* checkbox. Use the *Browse* button  to assign the folder location where the .dxf files are to be saved.
- iii. *Fast Nesting* and *Optimal Nesting* indicate the two different sets of algorithms used to implement Nesting.

Select the option that best suits your requirements. Time Constraint can be applied to *Optimal Nesting* if required.

- iv. The parameters in the *Nesting Data* group box are discussed in detail in the section [Options Parameters](#).



Create Nesting Job

Part data | Sheet data | Multi head options | Options

Part to part distance: 10mm

Part to sheet distance: 10mm

Ignore Part Thickness

Align part face with sheet: Default

Assembly Template: C:\ProgramData\SolidWorks\SOLIDWORKS 2018\templates

Save output as dxf : C:\ProgramData\NESTINGWorksData\NESTINGWorks 2018x64\Examples

Generate Remnants

Type of Remnant: Rectangular

Remnant Output: Sketches in Assembly Create separate remnant assembly

Area constraints:

Constraint type: Constraint By % of Sheet Area

Constraint value: 0.1 %

Width Constraints:

Constraint Type: Constraint By % of Sheet Height

Constraint Value: 0.1 %

Nesting type

Fast nesting Optimal nesting

Max. nesting time: min

Create separate assembly

Automatically select sheet

Restore Defaults Preview Nest... Cancel Help

'Options' Tab of Create Nesting Job dialog box

13. Click on the **Preview Nest...** button.

The *Nesting Preview* dialog box will be displayed.

The nested layout will display in the graphics area with the set parameters in the dialog box.

14. After all the parameters are confirmed, click *Generate Nested Assembly* in the Nesting Preview dialog box to execute the Nesting Job.

This sets into motion the process to generate a nested layout. Generating the layout might take some time depending on the complexity of the part.

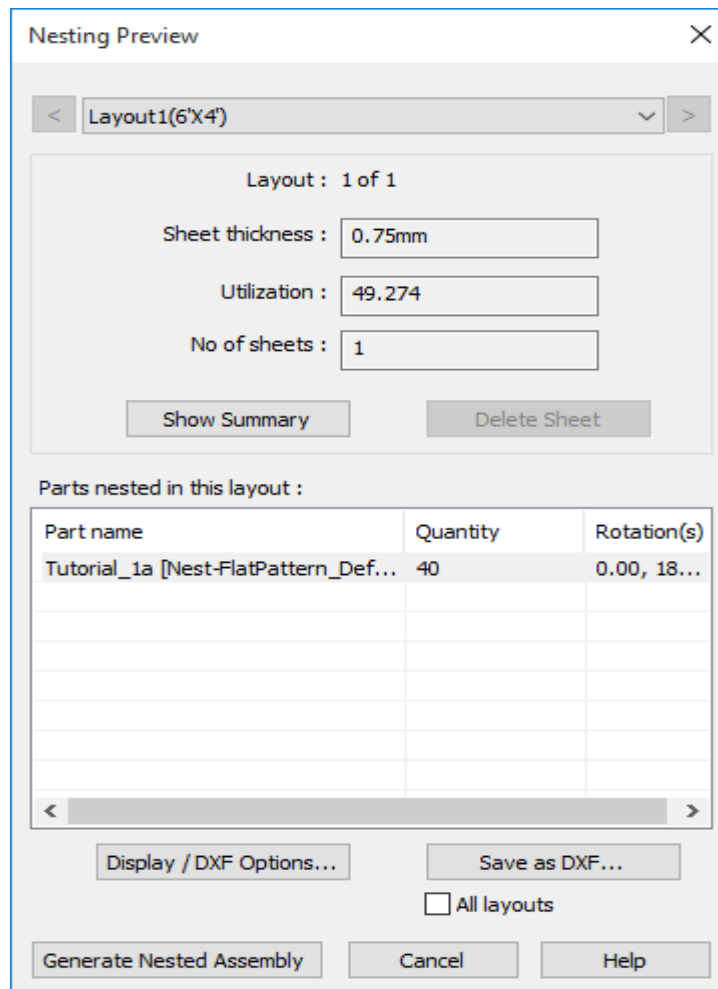

Nesting Preview dialog box

Two files will be generated during the nesting process, namely a text file and an assembly file.

After the Nesting process is completed, NESTINGWorks will display a message indicating the location of the text file containing the **summary of the Nest Results**. Click *OK* to close the message. The Text file will be displayed.



```

NestAssm-Tutorial_1a.SLDASM.ResultsSummary - Notepad
File Edit Format View Help
Nest Results Summary
=====
Total Number of Sheets Nested      : 1
Total Number of Part Instances Nested : 30
Overall Utilization                : 36.955
=====

Nested Part Quantity   Desired Quantity   Part Name
-----
30                    30                    Tutorial_1a [Nest-FlatPattern_Default]
-----

Total no. of Sheets   Parts per Sheet   Sheet Name
-----
1                     30                StdSheet1-S1(6'X4')
-----

Layout Name      : Layout1[Chrome Stainless Steel_0.75mm_Qnty1]
No. of Sheets   : 1
Sheet Name      : StdSheet1-S1(6'X4')
Sheet Length(mm): 1800.00
Sheet Width(mm) : 1200.00
Sheet Thickness(mm) : 0.75
Material         : Chrome Stainless Steel
Sheet Utilization : 36.955

Nested Qty per Sheet   Nested Qty per layout   Total Nested Qty   Part Name
-----
30                    30                    30                    Tutorial_1a [Nest-FlatPattern_Default]
-----

```

Result Summary text file for Tutorial_3.SLDPRT

The **Nested layout assembly** will be displayed in the Graphics area. Both these files are saved in the location indicated by *Output Assembly File* path stated in the *Apply Nesting* dialog box.

Note: The assembly file format (.sldasm) is the standard file format in which the nested layouts are generated. If the Save output as dxf option is used, then the nested layouts will be generated in two file formats: .sldasm & .dxf and saved in the specified folder locations.

Flowchart on Basic Procedure to Implement Nesting

A **flow chart** of the basic procedure to generate nested layouts using NESTINGWorks is given on the next page.

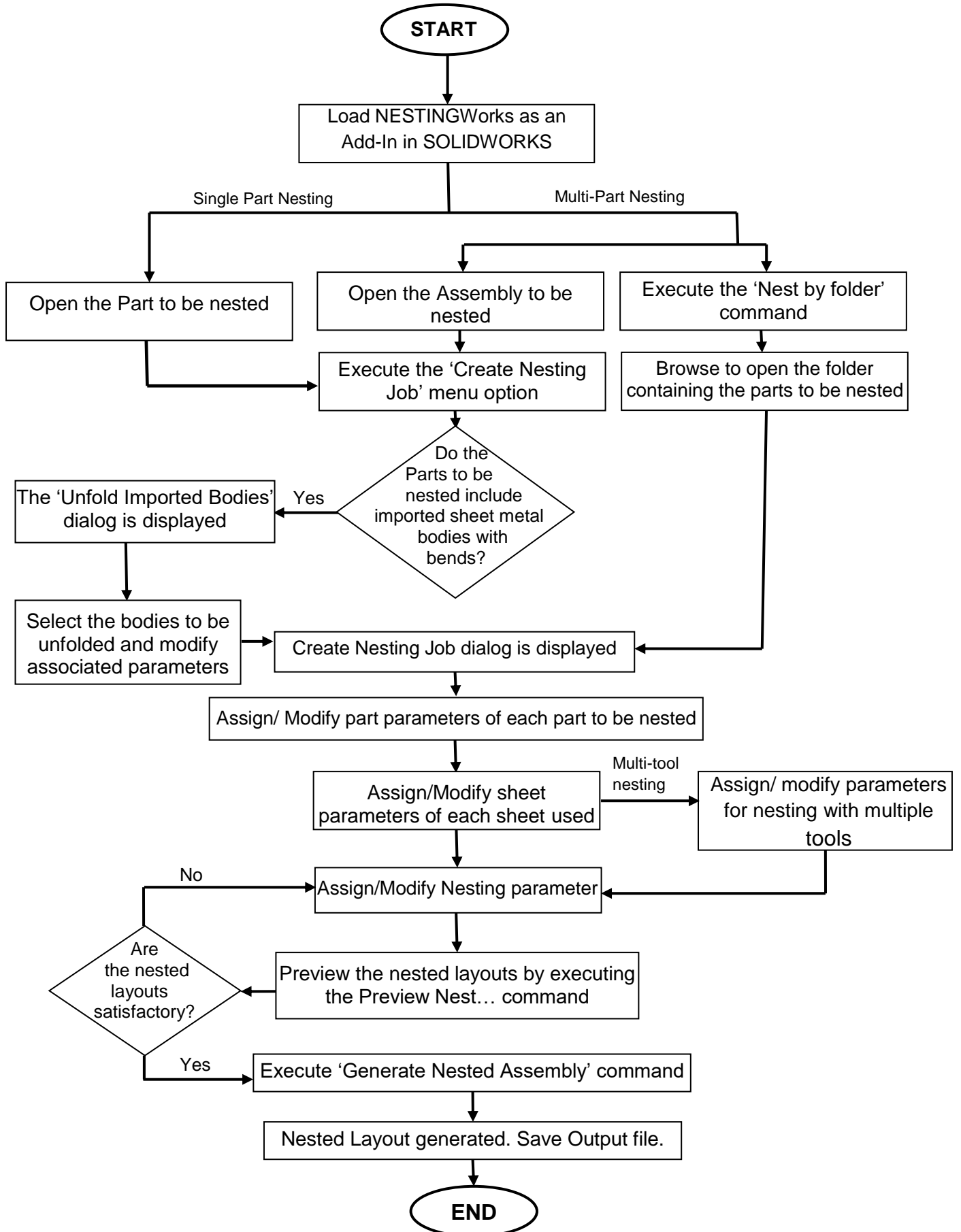

Steps to generate Nested Layouts using NESTINGWorks



The Part Model/Assembly

In NESTINGWorks, your part model is a solid created with SOLIDWORKS or imported into SOLIDWORKS from another CAD system via an IGES, STEP, Parasolid, SAT or other neutral translators. A part can contain multiple bodies.

Similarly, an assembly is a group of parts created with SOLIDWORKS or imported into SOLIDWORKS from another CAD system. An assembly can contain multi-body parts. Assemblies with parts having multiple configurations are supported.

The tutorials in this manual use existing SOLIDWORKS Parts installed with NESTINGWorks.

For example:

Open the assembly ***Tutorial_1.SLDASM*** located in the following folder of your NESTINGWorks installation folder.

C:\ProgramData\NESTINGWorksData\NESTINGWorks 201Xx64\Examples\Tutorials\Assemblies\Tutorial1

Select ***Create Nest Job*** command from the NESTINGWorks Ribbon bar.

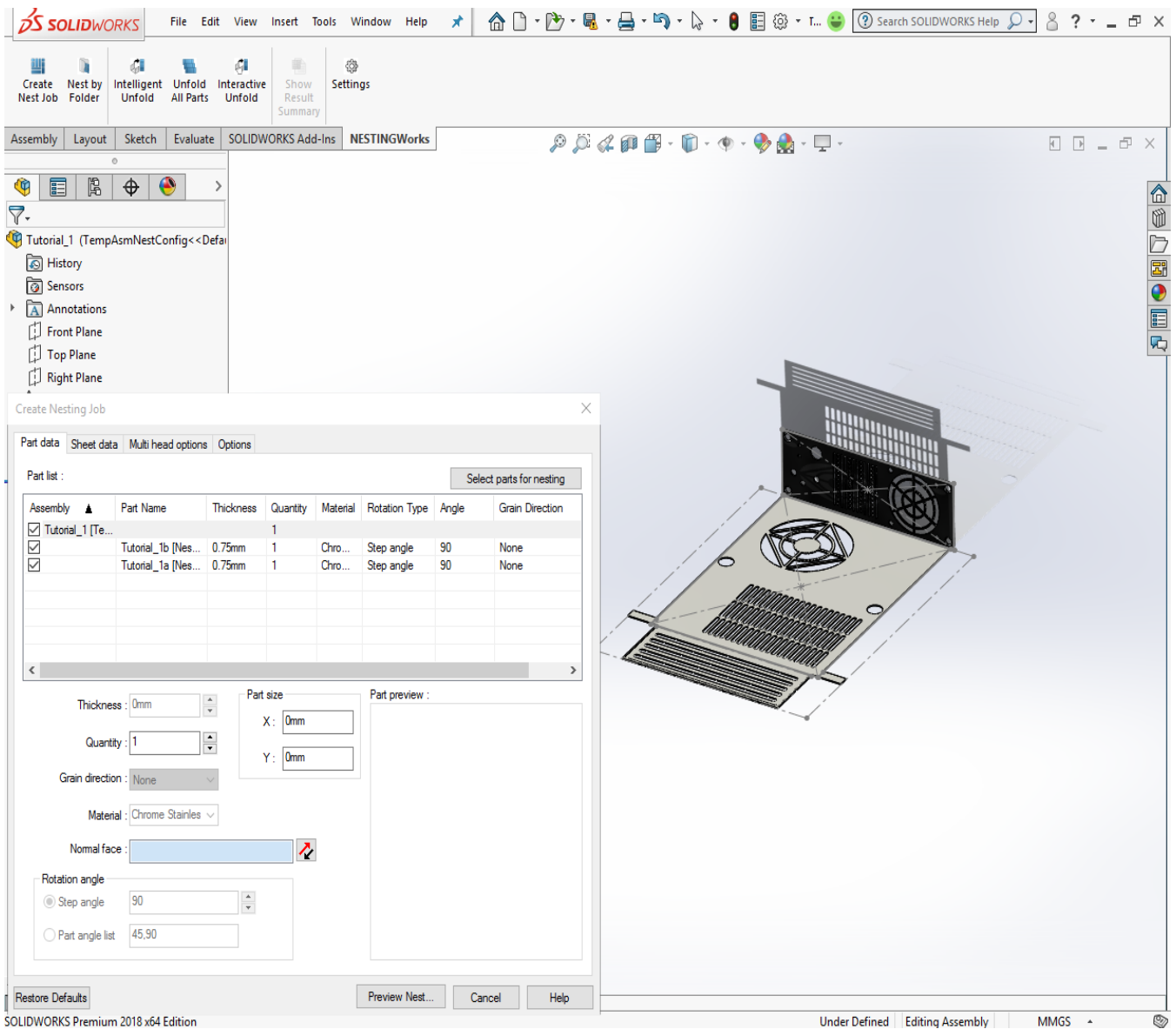

The NESTINGWorks Graphical User Interface



Defining Part Parameters

The *Create Nesting Job* dialog box is used to set the part, sheet and nesting parameters for Single Part nesting as well as Multi-Part nesting.

The Part data Tab

Use the *Part Data* tab of the *Create Nesting Job* dialog box to view and edit the part related parameters.

The Part Data tab is the default tab displayed when the *Create Nesting Job* dialog box is displayed.

The below data fields are available and can be edited in the *Part Data* tab:

- [Part List](#)
- [Thickness](#)
- [Quantity](#)
- [Grain Direction](#)
- [Material](#)
- [Normal Face](#)
- [Rotation Angle](#)



Create Nesting Job ✕

Part data | Sheet data | Multi head options | Options

Part list : Select parts for nesting

Assembly ▲	Part Name	Thickness	Quantity	Material	Rotation Type	Angle	Grain Direction
<input checked="" type="checkbox"/>	Tutorial_1 [Te...		1				
<input checked="" type="checkbox"/>	Tutorial_1b [Nes...	0.75mm	1	Chro...	Step angle	90	None
<input checked="" type="checkbox"/>	Tutorial_1a [Nes...	0.75mm	1	Chro...	Step angle	90	None

Thickness :

Quantity :

Grain direction :

Material :

Normal face :

Rotation angle

Step angle

Part angle list

Part size

X :

Y :

Part preview :

Restore Defaults Preview Nest... Cancel Help

Part Data Tab

Part List

The part parameters of *Part name*, *Thickness*, *Quantity*, *Material*, *Rotation Type*, *Rotation Angle* and *Grain direction* are displayed in the **Part List**. The Part parameters of **Thickness** and **Material** are extracted from the solid model part and displayed in the **Part List**.

All the above parameters except the Part name can be edited directly in the Part List. Alternatively, use the various Part parameter fields given below the Part List grid to edit the parameters.

To edit the part parameter fields, highlight the part to be edited in the part list and double-click on the required field. Edit the values as required.



Thickness

NESTINGWorks extracts the part parameter of Thickness from the Solid Part and displays it in the *Thickness* field as default thickness for the part.

To assign a desired thickness, enter the thickness value in the Thickness field.

The Thickness field in the Part List as well as Thickness field below the Part List grid can be used to edit the value.

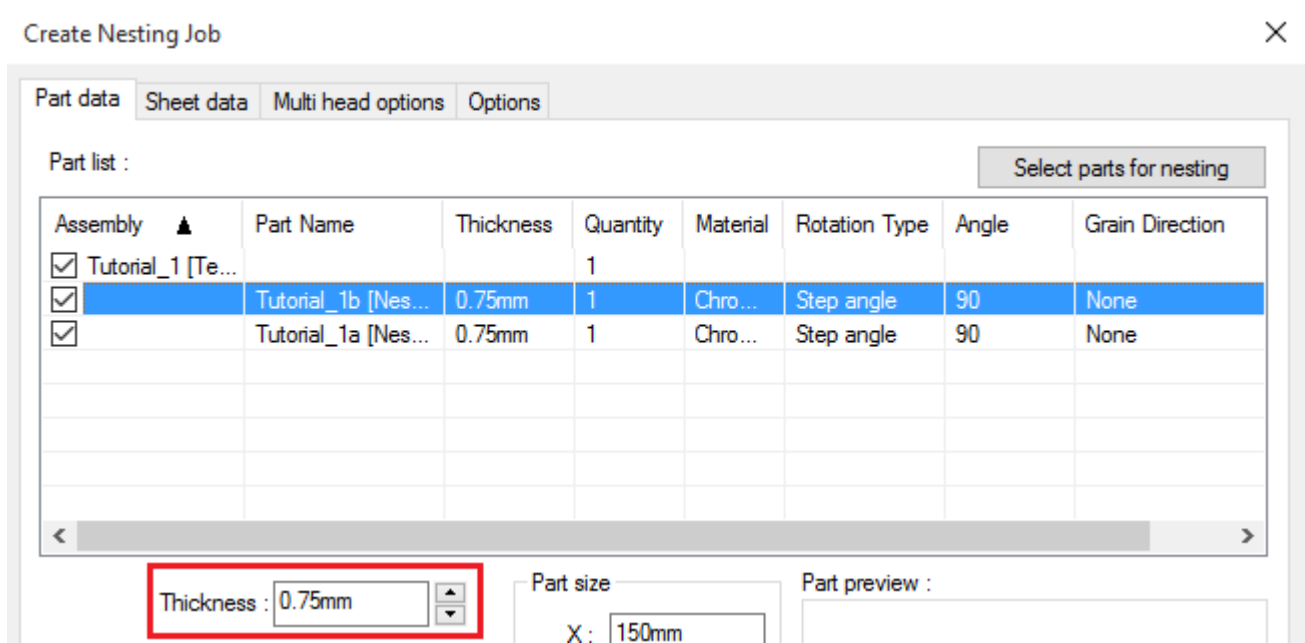

Assigning thickness value to a part

Quantity

The Part *Quantity* field indicates the number of instances of the part to be nested.

NESTINGWorks assigns a default quantity to all parts listed in the Part List.

Use the *Quantity* field to assign the number of instances of the part to be nested.

The quantity for a part can be set directly in the Part List.

Alternatively, you can highlight the part(s) in Part List for which this parameter is to be changed. Then change the quantity for the highlighted part using the Quantity field below the Part list grid. You can use spin control to increase or decrease the Quantity value. Spin control increases the value in steps of +1 and decreases it in steps of -1.

Note: For assemblies, default quantity assigned for a part is equal to the number of instances of the part in the assembly. For single part nesting, the default value assigned is based on the value defined in the **DefaultValues.ini** file. You can edit the default Quantity to be assigned for parts. For details, read: [Defining default Part quantity explained in NESTINGWorks Configuration Files and Associated Settings Guide.](#)



Create Nesting Job ✕

Part data | Sheet data | Multi head options | Options

Part list : Select parts for nesting

Assembly ▲	Part Name	Thickness	Quantity	Material	Rotation Type	Angle	Grain Direction
<input checked="" type="checkbox"/>	Tutorial_1 [Te...		1				
<input checked="" type="checkbox"/>	Tutorial_1b [Nes...	0.75mm	1	Chro...	Step angle	90	None
<input checked="" type="checkbox"/>	Tutorial_1a [Nes...	0.75mm	1	Chro...	Step angle	90	None

Thickness :

Quantity :

Part size

X :

Y :

Part preview :

Assigning Quantity to the parts to be nested

Grain Direction

To ensure accuracy and avoid defects during the subsequent mechanical operations like bending, it is necessary to cut critical parts, such that they have pre-defined and proper grain direction.

The *Grain direction* field is a drop down list from which you can choose any one of the following options:

- X direction
- Y direction
- None (*default option for both part and sheet*)
- Texture direction (*option available only for parts and not for sheets*)

The Grain Direction for a part can be set directly in the *Part list*. Alternatively, you can highlight the part(s) in *Part list* for which this parameter is to be changed. Then change the *Grain direction* for the highlighted part using the Grain direction dropdown list below the *Part list* grid.

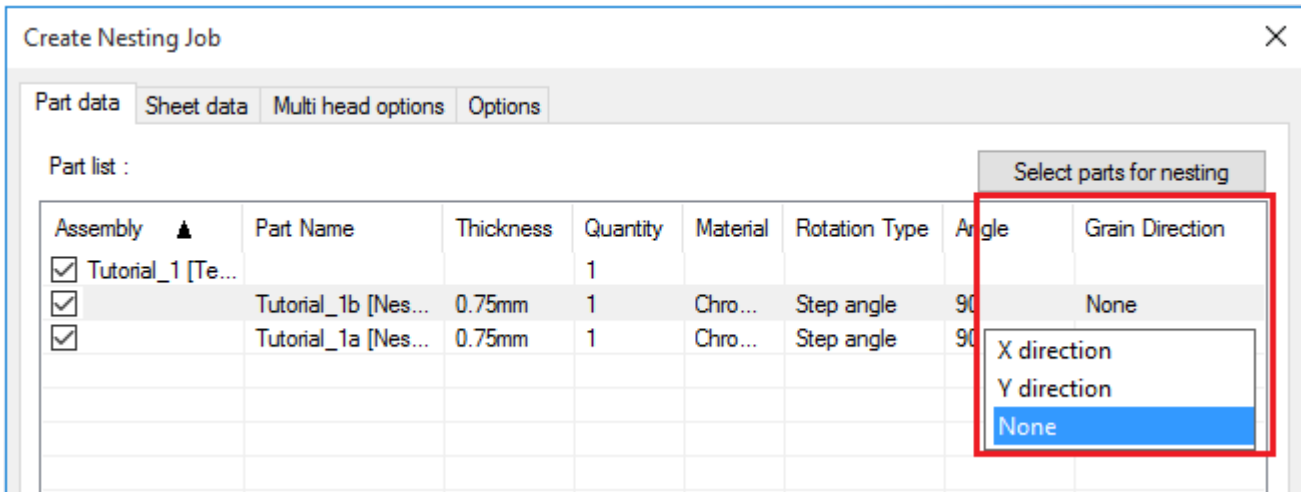

Assigning the grain direction for the part to be nested

Texture direction

Texture direction is listed as one of the options available for defining grain direction of the part to be nested. This option is listed in the *Grain direction* dropdown list of the *Part Data* tab only if the SOLIDWORKS property of texture has been applied to the face that has been selected as the Normal face for that part.

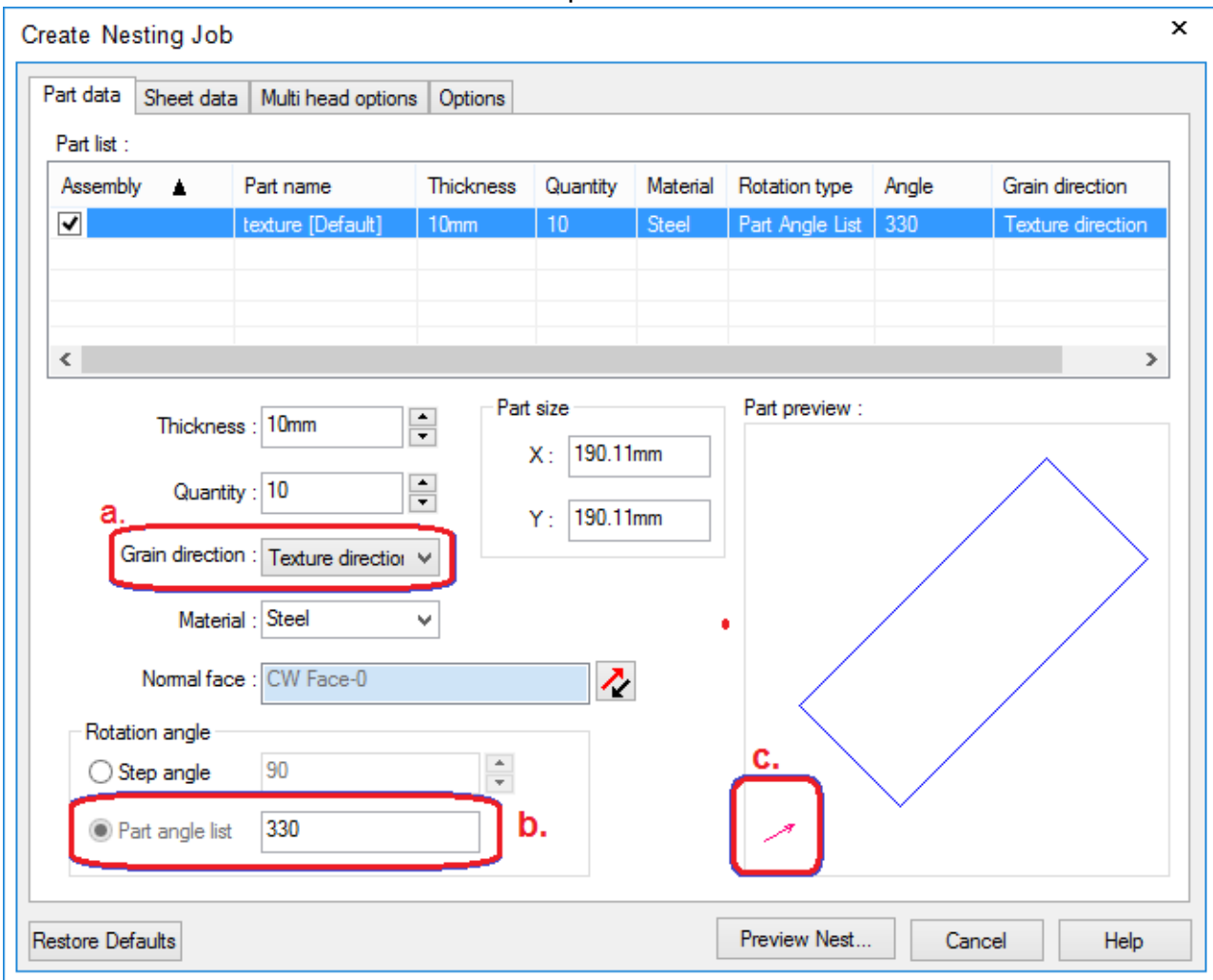

Assigning 'Texture direction' as the Grain direction for the part to be nested



Note:

The functionality for assigning *Texture direction* as the *Grain direction* for a part to be nested is available only when NESTINGWorks is used in conjunction with SOLIDWORKS 2016 or higher versions.

When *Texture direction* option is selected as the *Grain direction* for a part, the following will happen:

- a. The direction of the texture applied to the Normal face of the part will be considered when generating nested layouts.
- b. The Rotation angle computed for the selected *Grain direction* will be displayed in the *Part angle* list field of the Part Data tab and greyed out.
- c. An arrow indicating the grain direction will be visible in the Part preview area within the *Part data* tab as well as in the graphics area.

Material

NESTINGWorks extracts Material related information from the solid part in the SOLIDWORKS environment and displays it in the 'Material' field as default material for the part.

If the material value is not extracted from the 3D model then, NESTINGWorks assigns a default value. This default value will be the first material listed in the material dropdown list.

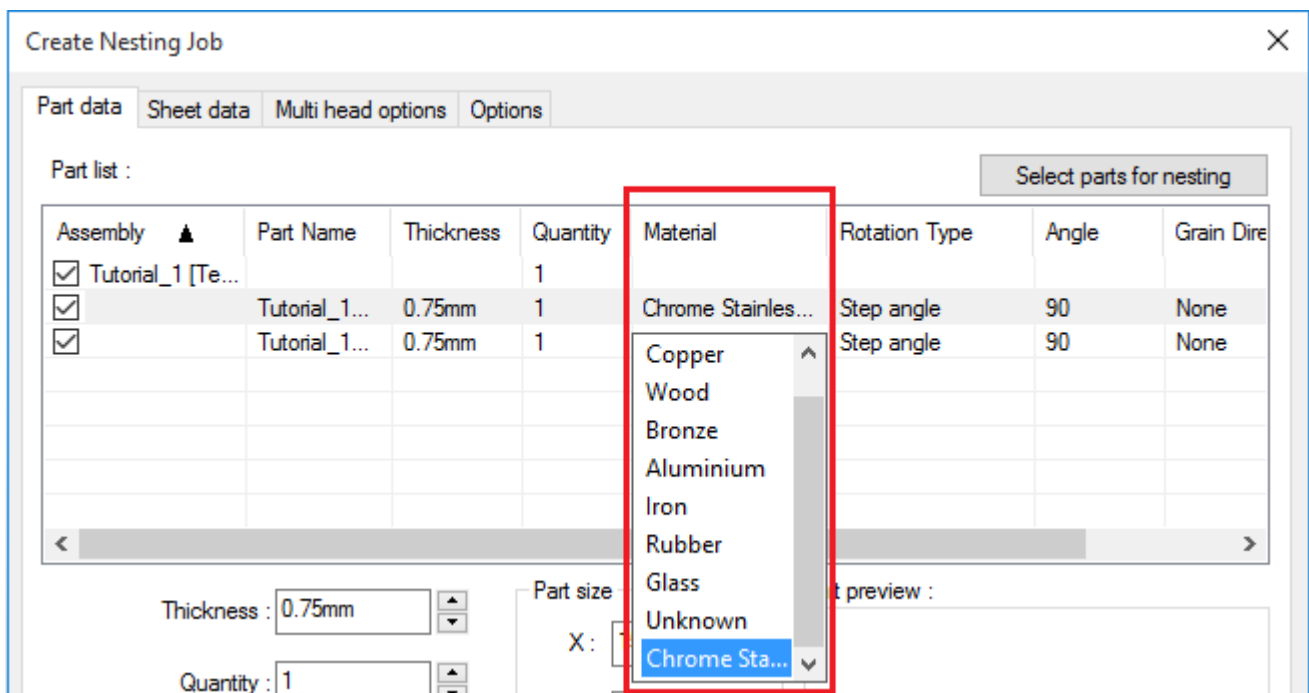

Assigning Material from dropdown list in Material Column

To assign a material from the material dropdown list, select the desired material from the dropdown list in the material column of the Part list. Alternatively, use the Material dropdown list given below the Part List grid.



A user-defined material (a material which is not part of the material dropdown list) can also be assigned to a part. However, such a user-defined material cannot be assigned to a part using the Part List.

Steps to assign User-defined Material

To assign a user defined material, following are the steps:

1. Select the Part (for which material is to be changed) in the Part List.
2. Enter the Material name into the Material combo box given below the Part List.
3. Shift the focus from this field by pressing the tab button. Observe that the new material assigned is reflected the Part List.

Enter user-defined material name in the field given below the Part list. It will then update the Material Column of Part List

Note: You must customize the material dropdown list to populate it with the materials used at your facility. For details, read: [Viewing/ Editing the Material dropdown list explained in NESTINGWorks Configuration Files and Associated Settings Guide.](#)

Normal Face

The Normal Face selection is used to select the part face to be used as a normal plane for generating silhouette profile of the part to be nested.

By default, NESTINGWorks uses the part face with the largest surface area as a normal plane to generate a silhouette profile. However, for certain solid/imported parts, a need may arise to select another face of the part for various reasons such as ease of machining, single setup machining etc. For such situations, NESTINGWorks provides the option to manually define the Normal face.



The Normal Face selection cannot be executed in the Part List grid.

Steps to change the Normal face direction of a part:

- i. Highlight the required part in the Part List grid.
- ii. Observe the graphics area. The part face with the largest surface area is selected as the normal face. A blue arrow on the part face indicates the normal direction.
- iii. In the graphics area, click on the face of the part that you wish to assign as the normal face.
- iv. The Normal face field will now list the selected face.
- v. Click  to reverse the normal direction.

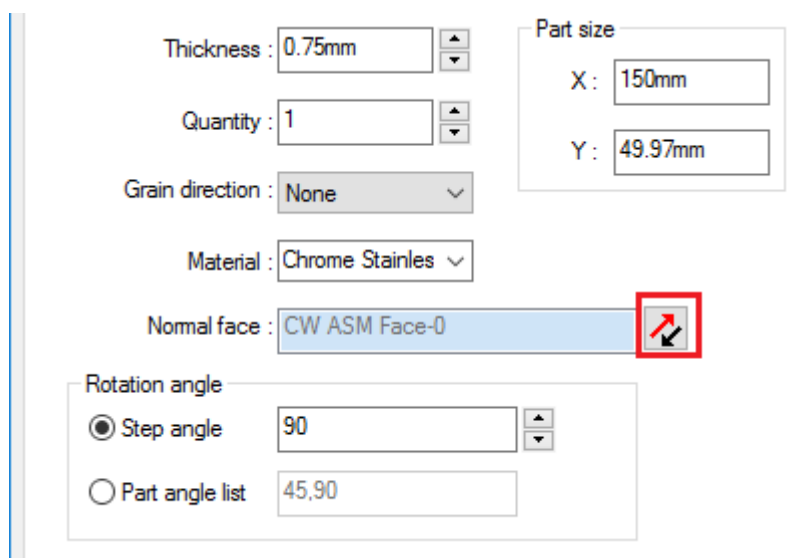

Normal Face Selection

Reverse Direction of Normal Face

Use the  toggle button to reverse the direction of the face selected as the normal face. Use this button to ensure that the correct face of the part(s) being nested is in the machining direction.

Illustration of when to use the 'Reverse Direction' button:

Consider the below part.



Face of part with lamination texture

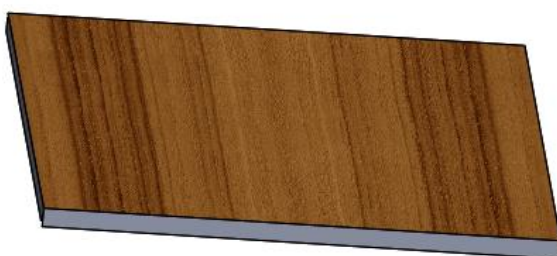
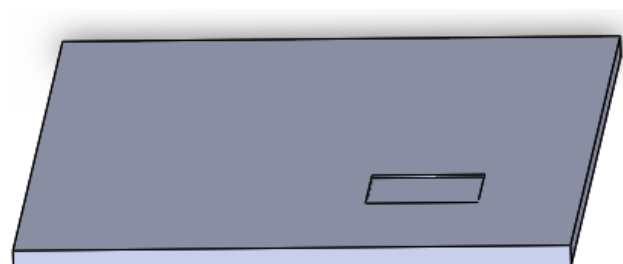

Opposite face of part with cutout section



- The face of the part in Z machining direction has lamination with texture.
- The face opposite this face of the part has a cutout pocket feature that needs to be machined.

When you execute the 'Create Nest Job' command for this part, the face of the part with largest surface area in Z machining direction will be selected as the normal face. In this case, it will be the face with lamination texture. A blue arrow in the graphics area will indicate the Normal direction. This normal direction needs to be reversed so that opposite face with the cutout section faces the Z Machining direction. Click on the *Reverse Direction*



toggle button in the *Create Nesting Job* dialog box to effect the change in Normal direction.

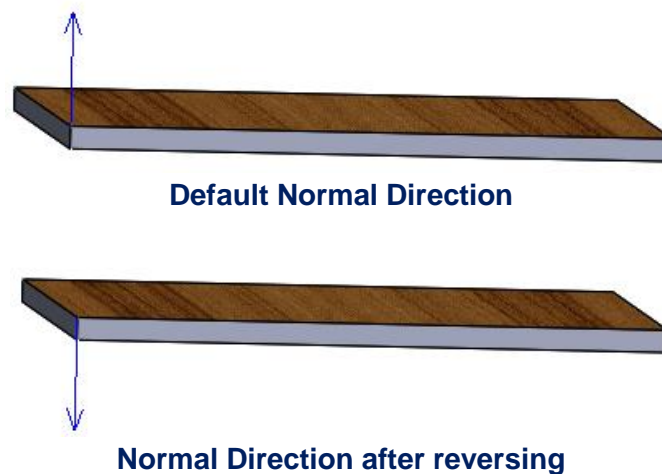

Setting default status for 'Reverse Direction' Toggle button

The status for the *Reverse Direction* toggle button on executing a new nesting job can be assigned in the **DefaultValues.ini** file explained in *NESTINGWorks Configuration Files and Associated Settings Guide*. By default, it is set to 'OFF'. If required, you can edit the default status of this button to 'ON' so that the normal direction for each part to be nested when executing a nesting job will be reversed.

This function is especially useful when multiple different parts are to be nested in a single nesting job and the normal direction for most or each of the parts needs to be reversed. Setting the default status of the *Reverse Direction* toggle button to 'ON' saves time as you will not need to individually select each part and reverse the normal direction by clicking on the *Reverse Direction* button. The normal direction for all parts will be reversed by default. For details, read: Assigning Default status for 'Reverse Direction' toggle button explained in *NESTINGWorks Configuration Files and Associated Settings Guide*.



Rotation Angle

NESTINGWorks provides two options for applying the rotation control for a part:

- **Step Angle:**

This is the angle that specifies the step in which the part is tried for nesting.

For example, if the Step angle provided for the part is 90 degrees, then that part will be tried in 90, 180, 270 and 360 degrees. The default step angle is 1°.

If step angle is 15°, then nesting of the part will be tried in 15, 30, 45, 60, 75, 90, 105, 120, 135, 150, 165 up to 360 degrees.

- **Angle List:**

This is the second way in which the rotation control can be applied on a part. The set of angles need to be input in a list. NESTINGWorks will then try nesting the parts only for the specified set of angles. To specify an Angle List in the Create Nesting Job dialog box, separate the angles by a comma. For example, to specify angles of 10, 20, 30, 60 and 90 degrees, you must enter '10, 20, 30, 60, 90' in the Part Angle List field.

The Rotation type and the subsequent Part angle can be set in the Part List. Alternatively, you can highlight the part(s) in Part List for which this parameter is to be changed. Then change the Rotation Type and part angle for the highlighted part in the **Rotation Angle** group box below the Part list grid.

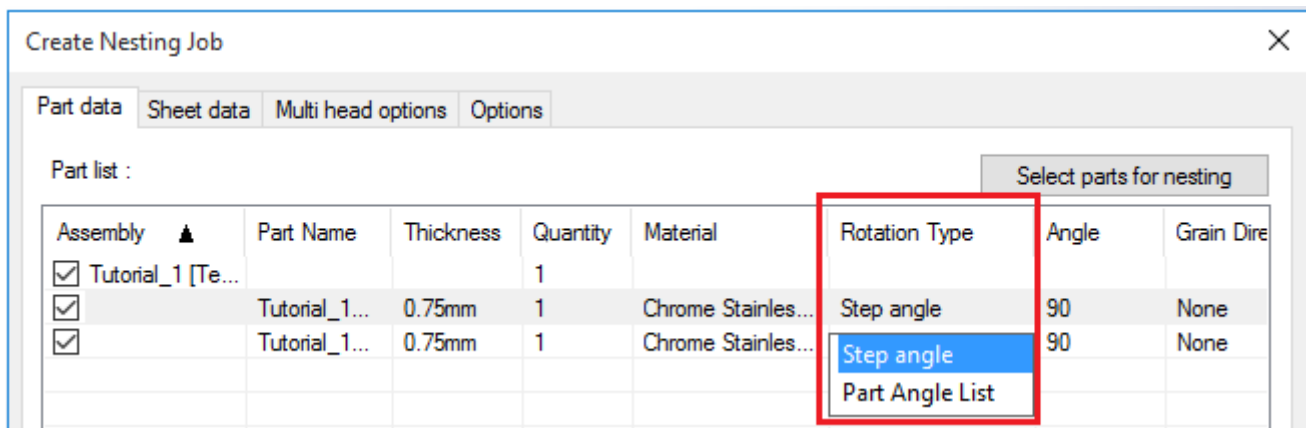

Assigning Rotation angle to the part

Note: If the feature for assigning assembly quantities is enabled, then the Quantity column will also display values in the Quantity column for the assembly to be nested as well as its constituent sub-assemblies, if any. Editing the quantity of the assembly or its constituent sub-assemblies updates the quantity of its constituent parts automatically. For more detail, refer: [Tutorial 9](#)



Defining Sheet Parameters

The *Create Nesting Job* dialog box is used to set the part, sheet and nesting parameters for Single Part nesting as well as Multi-Part nesting.

The Sheet data Tab

Use the *Sheet Data* tab of the *Create Nesting Job* dialog box to add sheet(s) and set the parameters for sheet(s) in which parts will be nested.

The *Part Data* tab is the default tab displayed when the *Create Nesting Job* dialog box is displayed. Click on the *Sheet Data* tab to view Sheet related data fields.

The below data fields are available and can be edited in the *Sheet Data* tab:

- [Sheet List](#)
- [Thickness](#)
- [Quantity](#)
- [Material](#)
- [Grain Direction](#)
- [Sheet Size](#)
- [Length](#)
- [Width](#)



Create Nesting Job ✕

Part data **Sheet data** Multi head options Options

Sheet list :

Sheet Name	Length	Width	Thickness	Material	Quantity	Grain Direction	Assembly Template	
StdSheet1-S1(6'X4')	1800...	120...	0.75mm	Chro...	1	None	Default	
Select to add sheet								

Thickness : ▲▼

Quantity : ▲▼ Sheet Forecaster

Material : ▼

Grain direction : ▼

Assembly template : ▼

Sheet type : ▼

▼

Sheet Data tab of Create Nesting Job dialog box

Sheet List

The Sheet List is populated by adding sheets using the *Add Sheet* button. Parts defined in the *Part Data* tab will be nested only on the sheet(s) listed in the *Sheet List*. The sheet parameters of *Sheet name*, *Length*, *Width*, *Thickness*, *Quantity*, *Material* and *Grain direction* are displayed in the **Sheet List**.

Of these parameters, *Thickness*, *Quantity*, *Material* and *Grain direction* parameters can be edited directly in the *Sheet List* grid after insertion. This is true for all sheet sizes. The parameters of *Sheet Name*, *Length* and *Width* can be edited only for Sheet of type *Custom Size*.

To edit the sheet parameter fields, highlight the sheet to be edited in the *Sheet List* and double-click on the required field to edit the values.



Thickness

Some intelligence is added in NESTINGWorks such that it ensures all sheets with relevant **Materials and Thicknesses** are available for nesting all the parts in the assembly. NESTINGWorks automatically extracts the thickness and material of the first part in the part list and assigns these as the default value of the first sheet. NESTINGWorks automatically checks for different material and thickness if any in the part list and assigns these as the default value of the second sheet and so on till all required sheets with relevant material and thickness are added.

For a sheet inserted in the *Sheet List*, the thickness field displays the sheet's thickness. Use the thickness field given below the sheet list to set the thickness value before adding the sheet to the *Sheet List*. Once the sheet is added to the *Sheet List*, the thickness value can be edited directly within the *Sheet List* in the respective field.

Quantity

The *Quantity* field indicates the number of sheets available. Use the *Quantity* field given below the sheet list to set the *Quantity* value before adding the sheet to the Sheet List. Once the sheet is added to the *Sheet List*, the *Quantity* field can be edited directly within the *Sheet List* in the respective field.

The default quantity assigned is based on the value defined in the **DefaultValues.ini** file. You can edit the default *Quantity* to be assigned for sheets. For details, read: Defining default Sheet Quantity explained in *NESTINGWorks Configuration Files and Associated Settings Guide*.

Material

For a sheet inserted in the Sheet list grid, the *Material* field displays the material the sheet is made of.

Use the Material field given below the sheet list to set the Material type before adding the sheet to the *Sheet List*. Once the sheet is added to the *Sheet List*, the material type can be edited directly within the *Sheet List* in the respective field.

Grain Direction

Grain direction can be set for a sheet just like it is set for parts. This field is a drop down list from which you must choose an option. The options are:

- X direction
- Y direction
- None (*default option for both part and sheet*)



Use the *Grain Direction* field given below the sheet list to set the *Grain Direction* before adding the sheet to the *Sheet List*. Once the sheet is added to the *Sheet List*, the *Grain Direction* field can be edited directly within the *Sheet List* in the respective field.

Assigning Grain directions

The Grain Direction which you can assign to a particular sheet is dependent on the Grain Direction of the Parts which will be nested within that sheet.

The allowed relationship between the Grain Direction of the part(s) and sheet is given in the following table:

Grain Direction of Part	Allowed Grain Direction for Sheet	Description
X	X or Y but not None	If a part has grain direction "X", then at least one of its corresponding sheets should have either "X" or "Y" but not "None" as its grain.
Y	X or Y but not None	If a part has grain direction "Y", then at least one of its corresponding sheets should have either "X" or "Y" but not "None" as its grain.
None	X or Y or None	If a part has grain direction "None", then the corresponding sheets can have either "X" or "Y" or "None" as its grain direction.
Texture direction	X *Y None	*Currently, there is a limitation in supporting "Y" direction for sheets when <i>Grain direction</i> for part is set to <i>Texture direction</i> . Support for "Y" direction will be available in a future version of NESTINGWorks.

Sheet Type

The Sheet List grid will initially be empty when you click on the *Sheet Data* tab of the *Create Nesting Job* dialog box. The size of the sheet in which the part(s) will be nested needs to be defined and then added to the *Sheet List*. NESTINGWorks provides three options with respect to sheet size:

- **Standard Size:**

The *Standard Size* dropdown box lists all the standard sheet sizes listed in the StandardSheets.ini file. This option is best exercised if you have defined the standard sheet sizes used at your facility in the **StandardSheets-INCH.ini** or **StandardSheets-MM.ini** file explained in *NESTINGWorks Configuration Files and Associated Settings Guide*.



- **Custom Sheet:**

The *Custom Sheet* option is best used when adding a non-standard size rectangular sheet or adding a custom sheet size.

The [default dimensions](#) (length and breadth) for the Custom sheet can be defined in the **DefaultValues.ini** file explained in *NESTINGWorks Configuration Files and Associated Settings Guide*. These default values will be displayed in the *Sheet Data* tab when you select the *Custom Size* option to execute a new nesting job.

- **DXF as Sheet:**

Only rectangular sheets can be defined using *Standard Size* and *Custom Size*. The *DXF* as sheet option is best used when you want to use a non-rectangular sheet or remnant sheet. In order to nest parts using such a non-rectangular or remnant sheet, the sheet should be saved in CAD graphic image file format called *Drawing Exchange format (.dxf)*.

Defining Standard Sheet

To add a standard size sheet, following are the steps:

- In the *Sheet data* tab, the row indicating *Select to add sheet* in the Sheet list would have been selected by default, if it is not selected then click on the row indicating *Select to add sheet* in the Sheet type.
- To define the sheet type, select the option *Standard* in the *sheet type dropdown list*.
- In the *Sheet type* dropdown list, select the required sheet type.
- Set the parameters of thickness, quantity, material and grain direction as required.
- Click on the *Add Sheet* button.
- The sheet is now added to the sheet list.



Thickness : 0.75mm

Quantity : 1 Sheet Forecaster

Material : Chrome Stainless S

Grain direction : None

Assembly template : Default

Sheet type : Standard

S1(6'X4') - Len: 1800mm Width: 1200mm

S1(6'X4') - Len: 1800mm Width: 1200mm

S2(6'X5') - Len: 1800mm Width: 1500mm

S3(6'X6') - Len: 1800mm Width: 1800mm

S4(7'X6') - Len: 2100mm Width: 1800mm

S5(8'X4') - Len: 2400mm Width: 1200mm

S6(8'X5') - Len: 2400mm Width: 1500mm

S7(8'X6') - Len: 2400mm Width: 1800mm

S8(8'X7') - Len: 2400mm Width: 2100mm

S9(8'X8') - Len: 2400mm Width: 2400mm

Add

Restore Defaults

Sheet preview :

Preview Nest... Cancel Help

Adding Standard Size Sheet to Sheet List

Defining Custom Sheet Type

To define a *Custom* sheet Type, following are the steps:

- In the *Sheet data* tab, the row indicating *Select to add sheet* in the Sheet list would have been selected by default, if it is not selected then click on the row indicating *Select to add sheet* in the Sheet list.
- In the Sheet data tab, select the option *Custom Sheet in the sheet type dropdown list*.
- The **Length and Width fields** are activated on selecting this option. Default values are displayed in these fields. (These values are defined in the DefaultValues.ini file explained in *NESTINGWorks Configuration Files and Associated Settings Guide*.) Edit the *Length* and *Width* fields to assign the required values. You can use spin control to increase or decrease the *Length* and *Width* values.
- Set *Thickness*, *Material* and *Grain Direction* values.
- Set the *Quantity* of the Sheet.
- Click on the *Add Sheet* button.
- The sheet is now added to the sheet list.



Adding Custom Size Sheet to Sheet List

Defining Sheet DXF

To use a sheet saved in DXF (*Drawing Exchange Format*) file format,

- In the *Sheet data* tab, the row indicating *Select to add sheet* in the Sheet list would have been selected by default, if it is not selected then click on the row indicating *Select to add sheet* in the Sheet list.
- In the *Sheet data* tab, select the option *DXF as Sheet* in the *Sheet type drop down list*.
- Click on the  button to browse to the folder location where the .DXF file is located.
- Set *Thickness*, *Material* and *Grain Direction* values.
- Click on the *Add Sheet* button.
- The Sheet saved in .dxf format will be added to the sheet list.
- A thumbnail view of the shape of the sheet will be displayed in the *Sheet Preview*.

Note: After a sheet is added to the Sheet list, its parameters can be edited either in Sheet List grid or in the respective fields below the Sheet list grid similar to part data editing.

Add Sheet & Remove Sheet buttons

Use the *Add Sheet* button to add a sheet to the Sheet List after setting its parameters.



To remove a sheet from the Sheet List, select the sheet to be deleted in the Sheet List and click *Remove Sheet*.

Defining Multi Head Options Parameters

The *Create Nesting Job* dialog box is used to set the part, sheet and nesting parameters for Single Part nesting as well as Multi-Part nesting.

For flame cutting applications, NESTINGWorks provides an optional functionality known as *Multiple Tool Head Nesting*. This functionality allows you to nest two or more identical layouts simultaneously using multiple tool heads. Machines which support nesting using multiple tool heads are known as *Multi tool head machines*.

The tab named *Multi head options* in the *Create Nesting Job* dialog box allows you to define/edit parameters related to nesting with multiple tool heads.

How the functionality of nesting with multiple tool heads works

When nesting layout(s) are to be generated using multiple tool heads, NESTINGWorks will first attempt to nest the parts using the user-specified number of tool heads. Suppose this tool heads number is 'n'. If a best-fit layout is achievable, NESTINGWorks will generate 'n' identical nesting layouts on the sheet.

If a best-fit nesting layout is not achievable with this number, then NESTINGWorks will try to nest using 'n-1' number of tool heads. If this number too fails, then it will try to nest using 'n-2' tool heads and so on until finally nesting with a single tool head.



The Default Settings in the Multi Head Options tab

Click on the *Multi Head Options* tab of the *Create Nesting Job* dialog box.

Machine data

Machine:

Number of tool heads:

Rail direction

X Y

Multi-tool head nesting type

Fixed tool head distance

Variable tool head distance

Tool head distance

Tool head distance:

Sheet preview :

Sheet Name	Length	Width	Thickness	Material	Quantity	Grain Direction	Assembly Template
StdSheet1-S1(6X4)	1800...	120...	0.75mm	Chro...	1	None	Default
CustomSheet1(3000x1000)	3000...	100...	0.75mm	Chro...	1	None	Default

The Multi Head Options tab (as typically seen with default settings)

Observe the Machine Data group box. The default machine displayed in the Machine field is *SingleTHMachine*. The *Number of tool heads* for this machine is '1'.

SingleTHMachine (Single Tool Head Machine)

SingleTHMachine is representative of machines with a single tool head. Such machines are usually used for the nesting process. When this machine is selected in the Multi Head Options tab, the functionality of nesting with multiple tool heads will be disabled for the current nesting job. All the parameters fields related to Multiple Tool Head Nesting in the tab are disabled, indicating that Multiple Tool Head Nesting functionality is disabled.



Enabling Multi Tool Head Machining

To generate nested layouts using a machine with multiple tool heads instead of the default Single Tool Head machine, you need to select a machine with multiple tool heads in the *Machine* field of the *Multi Head Options* tab.

For nesting with Multiple Tool Heads, select a machine other than *SingleTHMachine* in the *Machine* dropdown list. The number of tool heads possessed by the selected machine is listed in the *Number of tool heads* field. If the machine has two or more tool heads, nesting with Multiple Tool Heads will be enabled for the current nesting job.

Machine data

Machine: SingleTHMachine

Number of tool heads: 1

Rail direction

X Y

Multi-tool head nesting type

Fixed tool head distance
 Variable tool head distance

Tool head distance

Tool head distance: 150mm

Sheet preview :

Restore Defaults Preview Nest... Cancel Help

The Multi Head Options tab (as typically displayed when Multiple Tool Head Nesting is active)

Parameters and Data fields in the Multi Head Options tab

This tab provides an interactive interface to view/edit the parameters related to nesting with multiple tool heads. The following data fields are available in the *Multi head options* tab:

- [Sheet List](#)
- [Machine name](#)
- [Number of Tool Heads](#)
- [Rail Direction](#)
- [Multi-tool nesting type option](#)
- [Tool head distance](#)



Sheet List

The Sheet List is populated by the sheets listed in the Sheet data tab of the Create Nesting Job dialog box. Unlike the Sheet List grid in the Sheet Data tab, this grid is read-only. For nesting with multiple tool heads, a separate set of parameters needs to be defined for each individual sheet listed in the Sheet List.

To define these parameters, highlight the desired sheet in the Sheet List. The default values of these parameters will be displayed below the Sheet List grid in their corresponding fields. Proceed to edit the parameters as desired.

Machine (machine name)

The default machine displayed in the *Machine* field is the **SingleTHMachine**. When this machine (representative of Single Tool Head Machines) is selected, nesting with multiple tool heads is disabled. All the other parameter fields in the *Multi Head Options* tab which are related to Multiple Tool Head Nesting will be disabled.

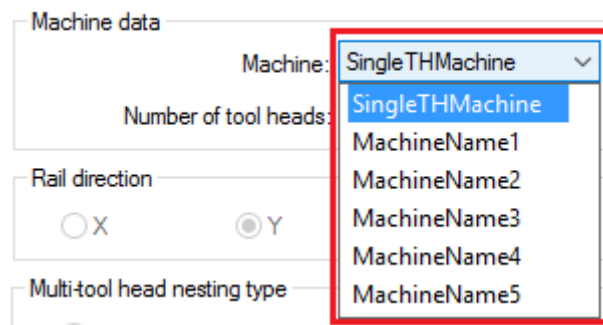

Machine data dropdown list

All the other machines listed in the *Machine* dropdown list support Nesting with Multiple Tool Heads. To enable nesting with multiple tool heads, select the desired machine (other than *SingleTHMachine*) from the dropdown list.

When such a machine is selected, the default parameter values associated with that machine are displayed in the *Multi head options* tab. These default parameter values for each machine are defined in the Machine.ini file.

The *Machine* dropdown list is populated with the Machine names listed in the Machine.ini file explained in *NESTINGWorks Configuration Files and Associated Settings Guide*. Before executing a nesting job using multiple tool heads, ensure that you customize the Machine.ini file to suit your nesting job requirements.

Number of Tool Heads

For every machine listed in the *Machine* dropdown list, the [maximum number of permissible tool heads](#) is defined in the Machine.ini file. When you select a particular machine from the *Machine* dropdown list, the maximum permissible number of tool heads for that machine is displayed in the *Number of tool heads* dropdown list.



The screenshot shows a configuration window with three sections: 'Machine data', 'Rail direction', and 'Multi-tool head nesting type'. In the 'Machine data' section, 'Machine:' is set to 'MachineName5'. The 'Number of tool heads:' dropdown is open, showing a list of numbers from 1 to 5. The number '5' is highlighted in blue. The 'Rail direction' section has radio buttons for 'X' and 'Y', with 'Y' selected. The 'Multi-tool head nesting type' section has radio buttons for 'Fixed tool head distance' and 'Variable tool head distance', with 'Fixed tool head distance' selected.

Number of tool heads dropdown list

Based on your nesting requirements, you have the option of choosing any number ranging from 1 to this maximum number from the *Number of tool heads* dropdown list.

Rail direction

Rail direction is defined as the direction the master tool head follows while cutting. It can be either horizontal (X) or vertical (Y). When the rail direction is horizontal, the slave tool heads are either to the top or to the bottom of the master tool head. When the rail direction is vertical, slave tool heads lie either to the left or to the right of the master tool head.

The tool heads are arranged along the height of the sheet when the rail direction is 'X' and along the length of the sheet if the rail direction is 'Y'.

When you select a particular machine from the *Machine* dropdown list, the default *Rail direction* for that particular machine is displayed with the *Multi head options* tab. This default value is defined in the *Machine.ini* file explained in *NESTINGWorks Configuration Files and Associated Settings Guide*. You can change the *Rail direction* to suit your nesting job requirements.

Multi-tool head nesting type

You can choose any one of the following *Multi-tool head nesting type* option:

1. **Fixed tool head distance:** When this option is chosen, the distance between the tool heads is fixed to the minimum tool head distance.
2. **Variable tool head distance:** When this option is chosen, the distance between tool heads can vary but will be greater than the minimum tool head distance.

The screenshot shows the 'Multi-tool head nesting type' section with two radio button options: 'Fixed tool head distance' and 'Variable tool head distance'. The 'Variable tool head distance' option is selected, indicated by a blue dot in the radio button.

Selection the Multi-tool head nesting type option



When you select a particular machine from the *Machine* dropdown list, the default *Multi-head nesting type* option for that machine is displayed in the *Multi Head Options* tab. This default option is assigned in the *Machine.ini* file explained in *NESTINGWorks Configuration Files and Associated Settings Guide*. You can change this default option to suit your nesting job requirements.

Tool head distance

The *Tool head distance* value indicates minimum tool head distance to be used for a nesting job involving multiple tool heads.

When you select a particular machine from the *Machine* dropdown list, the default *Tool head distance* value for that particular machine is displayed with the *Multi head options* tab. This default value is defined in the *Machine.ini* file explained in *NESTINGWorks Configuration Files and Associated Settings Guide*.

Editing the default settings for the Multi Head Options tab

The nesting specific information and default parameter values for machines which support nesting with multiple tool heads is defined in the ***Machine.ini*** file located in the `C:\ProgramData\NESTINGWorksData\NESTINGWorks 201Xx64\Config` folder.

If you intend to make use of the feature of nesting with multiple tool heads, then the *Machine.ini* file can be customized depending on your requirements. For a detailed understanding of how to customize this file, read the section on *Machine.ini* explained in *NESTINGWorks Configuration Files and Associated Settings Guide*.

Define Nesting Data Parameters

The Options Tab

The *Options tab* of the *Create Nesting Job* dialog box is used to set the following nesting parameters:

- [Part to Part Distance](#)
- [Part to Sheet Distance](#)
- [Output Assembly File path](#)
- [Assembly template path](#)
- [Save output as dxf](#)
- [‘Automatically Select Sheet’ option](#)
- [‘Create separate assembly’ option](#)
- [Nesting Type](#)
- [Nesting Time \(in minutes\)](#)



Part data Sheet data Multi head options Options

Part to part distance : 10mm

Part to sheet distance : 10mm

Ignore Part Thickness

Align part face with sheet : Default

Assembly Template : C:\ProgramData\SolidWorks\SOLIDWORKS 2018\templates

Save output as dxf : C:\ProgramData\NESTINGWorksData\NESTINGWorks 2018x64\Examples

Generate Remnants

Type of Remnant : Rectangular

Remnant Output : Sketches in Assembly Create separate remnant assembly

Area constraints :

Constraint type : Constraint By % of Sheet Area

Constraint value : 0.1 %

Width Constraints :

Constraint Type : Constraint By % of Sheet Height

Constraint Value : 0.1 %

Nesting type

Fast nesting Optimal nesting

Max. nesting time : min

Create separate assembly

Automatically select sheet

Restore Defaults Preview Nest... Cancel Help

The Options tab of 'Create Nesting Job' dialog box

Part to Part Distance

The *Part to Part Distance* indicates the distance to be maintained between two nested parts in the sheet. The default value is zero. Assign the required value by entering it in the field.

Part to Sheet Distance

The *Part to Sheet Distance* indicates the distance to be maintained between a part and the edge of the sheet. The default value is zero. Assign the required value by entering it in the field.



Assembly Template Path

An assembly templates (*.asmdot) is a template document that includes user-defined parameters and customized options which forms the basis for new assemblies.

Use the button given next to the Assembly template field to browse to the location where the desired assembly template is saved. In NESTINGWorks, the default assembly template loaded is the one defined in the Default Templates section of the SOLIDWORKS Systems Options. Save output as dxf

The CAD data file format called *Drawing Exchange format (.dxf)* is an international standard which enables data interoperability between AutoCAD and other programs. The *Save output as dxf* checkbox option is a feature which allows you to save the nested layouts which are generated after executing a nesting job in the **.dxf** format.

Use the button given next to this field to browse to the folder location where the .dxf files are to be saved. This field which is used to specify the folder location is enabled only when the *Save output as dxf* checkbox is checked.

If the *Save output as dxf* option is used when multiple nested layouts are generated (saved either as separate configurations or as separate assembly files), then a separate .dxf file will be created for each nested layout that is output and saved in the specified folder location.

When the *Save output as dxf* checkbox is not checked, then the nested layouts generated after executing a nesting job will be saved only in the assembly file format (*.sldasm*).

Note: The assembly file format (.sldasm) is the standard file format in which the nested layouts are generated. If the Save output as dxf option is used, then the nested layouts will be generated in two file formats: .sldasm & .dxf and saved in the specified folder locations.

Automatically Select Sheet

For a nesting job containing multiple parts and sheet types, it is difficult for the user to select the best sheet type or best sequence of sheets in order to obtain best yield based on the sheet utilization factor. Since it is very important to predict and procure the inventory in correct numbers, an Inventory Forecasting Module (IFM) which forecasts the optimum sheet inventory is necessary.

The Inventory Forecasting Module operates within NESTINGWorks in the form of **Automatically Select Sheet** option.

Automatic Sheet Selection supports two methods:

1. Unique Sheet Forecaster

If this method is selected, the feature would select one best sheet among the set of sheets considered, depending upon overall utilization obtained. After knowing which sheet type is the best for that particular nesting order, the user can place an order



for that much quantity of the sheet type. This will help in reducing the sheet variety – thus reducing the time required for machine specific sheet settings.

2. Combinatorial Sheet Forecaster

If this method is selected, the feature selects a combination of sheet types from the set of sheets available in the Sheet list, depending on the overall utilization obtained.

Setting the Forecaster Method in DefaultValues.ini

At any given point of time, only one of the above mentioned Forecasting methods can be used. This setting is available in the DefaultValues.ini file explained in *NESTINGWorks Configuration Files and Associated Settings Guide*. The default method is *Combinatorial Sheet Forecaster*.

Create Separate Assembly

The *Create separate assembly* option is available under the Nesting Data group box in the *Create Nesting Job* dialog box.

When multiple nesting layouts are generated after the execution of a nesting job, NESTINGWorks lists all the nested layouts under the Configurations Manager Tab of SOLIDWORKS. These nested layouts are saved as a part of a single assembly file (*.sldasm).

If you wish to generate separate assemblies for each such nested layout generated, the select the *Create Separate Assembly* option. After executing a nesting job, all the nested layouts will then be saved as separate assemblies in the destination folder specified in the *Output Assembly* file location.

Nesting Type

Fast Nesting and *Optimal Nesting* indicate the two different sets of algorithms used to implement Nesting.

- **Fast Nesting:**

This method should be used when nesting quickly is more important than optimal sheet utilization.

- **Optimal Nesting:**

This method focuses on optimal utilization of the sheet by running multiple algorithms and chooses the best result in terms of utilization. It is the default setting for NESTINGWorks.

Max Nesting time

Time constraints can be applied to optimal nesting. The *Max. nesting time* field is enabled when the *Nesting type* is set to *Optimal Nesting*. Use this field to enter nesting time limit in minutes. This will restrict the maximum allowable time for nesting to the set value. The default value for max nesting time field is *No constraint*, which indicates that a full optimal nesting will be run without any time constraints.



Note: Optimal Nesting option is not available for a nesting job that uses multiple tool heads. In other words, the Optimal Nesting option is disabled when the functionality of nesting with multiple tool heads is enabled.

Previewing the Nested Layout

To execute a fresh nesting job, click the *Preview Nest...* button to preview the nested layout(s) that will be generated based on the current settings in the *Create Nesting Job* dialog box. This action will open the Nesting Preview window and also display a two-dimensional preview of the nested layout(s) in the SOLIDWORKS graphics area. The preview will be displayed in the graphics area as long as the Nesting Preview dialog box is open.

Viewing the 2D layout(s) in the graphics area allows you to determine if the nested layout results are satisfactory or not.

- If the results are satisfactory, click on the *Generate Nested Assembly* button in the Nesting Preview window to execute the nesting job.
- If nested layout results are not satisfactory, then you can close the Nesting Preview window and go back to the *Create Nesting Job* dialog box and modify the input parameters. Repeat the process of previewing the layout(s) till satisfactory results are obtained and then click on the *Generate Nested Assembly* button in the Nesting Preview window to execute the nesting job

Generating the Nested Layout

After observing the satisfactory result in the Nesting Preview window, click *Generate Nested Assembly* button.

This sets into motion the process to generate a nested layout. Generating the layout might take some time depending on the complexity of the part.

Two files will be generated during the nesting process, namely a text file and an assembly file.

After the Nesting process is completed, NESTINGWorks will display a message indicating the location of the text file containing the **summary of the Nest Results**. Click *OK* to close the message. The Text file will be displayed.

The **Nested layout assembly** will be displayed in the Graphics area. Both these files are saved in the location indicated *Output Assembly* file path stated in the *Apply Nesting* dialog box.

How the Nested layouts generated are saved within SOLIDWORKS

Once the nesting process using the NESTINGWorks application is completed, the nested layout(s) generated will always be saved as a SOLIDWORKS assembly file (**.sldasm*).

Depending on various factors such as thickness and/or material part of part, number of sheets, grain direction, etc., either one or multiple Nested layouts will be generated.

- **When only one nested layout is generated:**



- The will be saved as a SOLIDWORKS Assembly file comprising of nested parts.
- The sheet dimensions will be saved as a SOLIDWORKS sketch.
- **When multiple nested layouts are generated:**
 - These nested layouts will be saved as a SOLIDWORKS Assembly file comprising of assemblies. Each assembly is a nested layout comprising of nested parts.
 - The sheet dimensions for each sheet will be saved as a SOLIDWORKS sketch.

Once the nested layout(s) are generated, each nested layout assembly (sheet layout containing nested parts) will be listed in the *SOLIDWORKS Configurations Manager*.



TUTORIAL 1 - NESTING AN ASSEMBLY

This tutorial is intended to give you a preview of how nesting is done for a simple assembly file comprising sheet metal parts. The sheet metal parts will be nested using a single tool head.

Generating a nested layout as explained in this tutorial will help you understand better the concepts explained in the *NESTINGWorks Configuration Files and Associated Settings Guide*.

Step 1: Open the Assembly

1. Load the *NESTINGWorks* Add-In in SOLIDWORKS.
2. Open the assembly file **Tutorial_1.SLDASM** located in the *NESTINGWorks* installation folder. ([Refer page 23](#))

C:\ProgramData\NESTINGWorksData\NESTINGWorks 201Xx64\Examples\Tutorials\Assemblies\Tutorial1

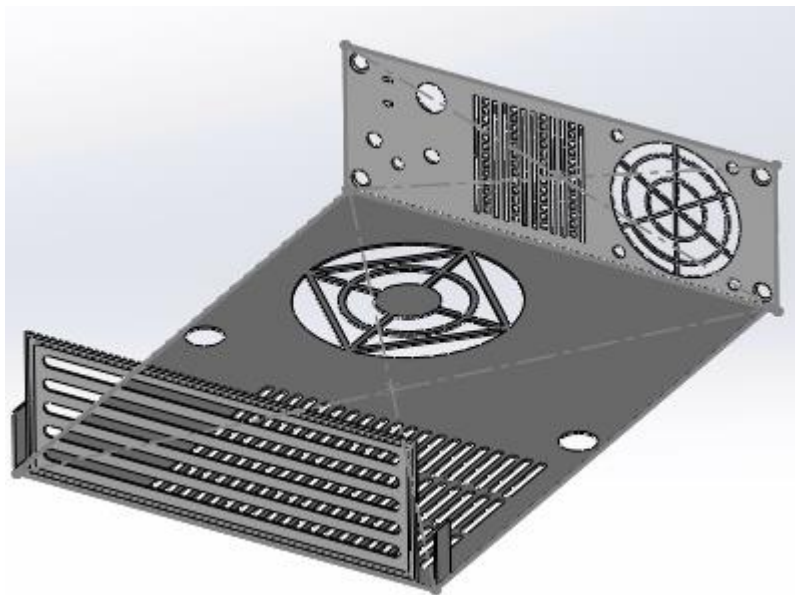

Tutorial_1.sldasm

Step 2: Assign Nesting Parameters

1. Select *Create Nest Job* from the *NESTINGWorks* cascading menu.

OR

Click on the *Create Nest Job* button on the *NESTINGWorks* Ribbon Bar.

The *Select Parts for Nesting* dialog box will be displayed.

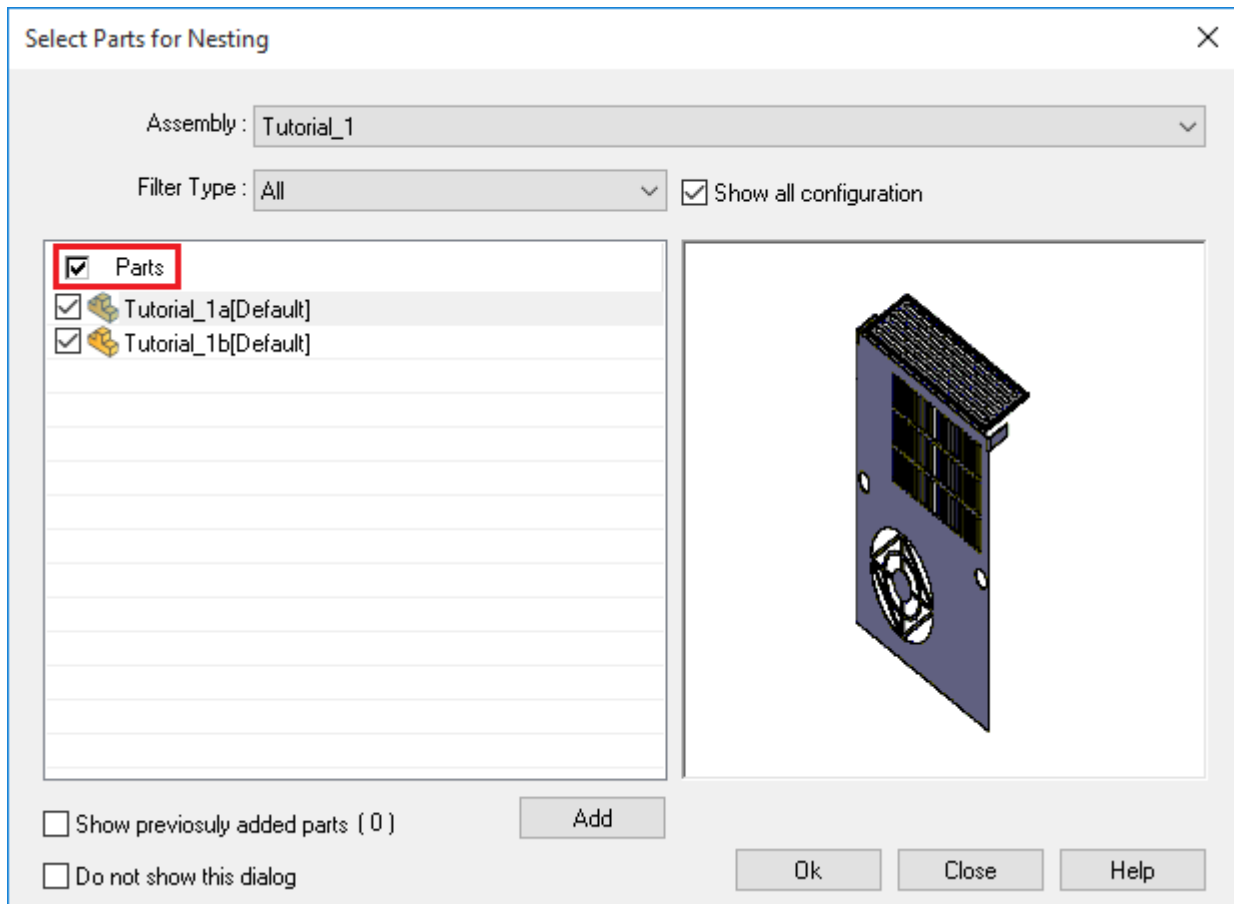

'Select Parts for Nesting' dialog box

2. Within this dialog box:
 - a. Set the *Filter Type* to **All**. (This ensures that all components of the assembly are displayed.)
 - b. To select all the parts for nesting, place a tick in the checkbox next to **Parts**. (This action ensures that all listed components of the assembly are selected for nesting.)
 - c. Click the **OK** button in this dialog box.
The *Create Nesting Job* dialog box is displayed.
3. Click on the **Multi head options** tab and ensure that **SingleTHMachine** is the machine listed in the *Machine* field.

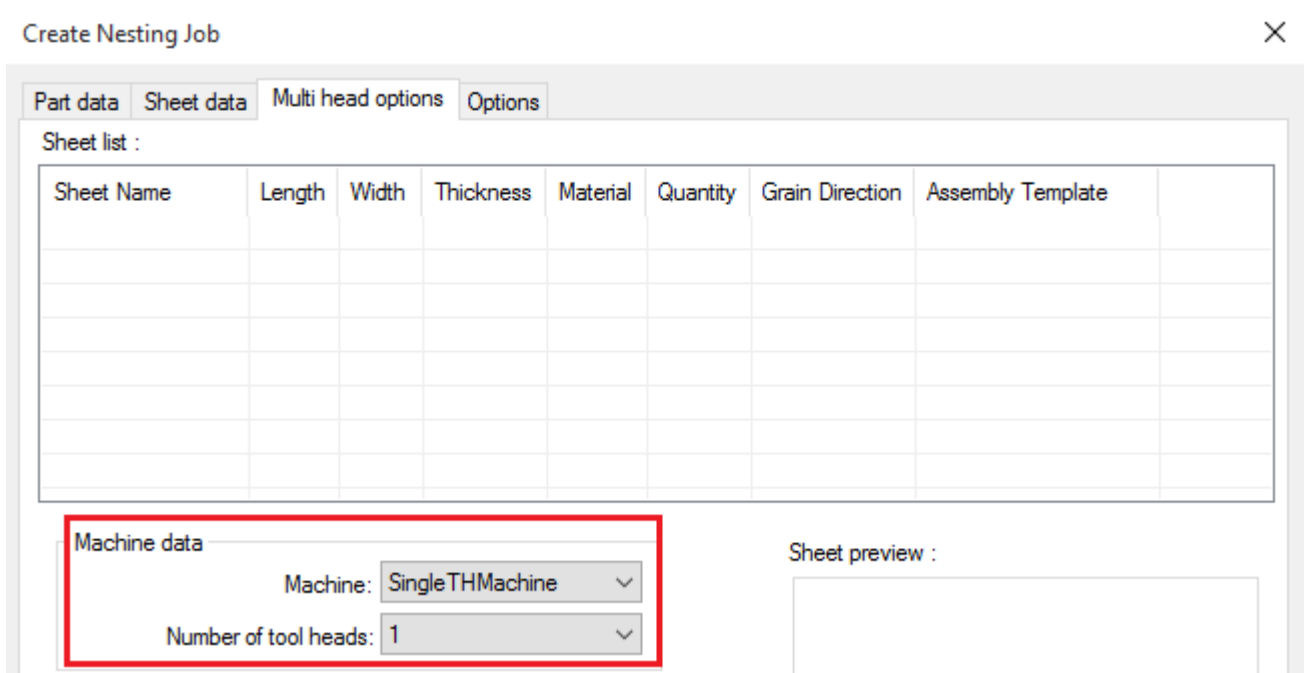

‘Multi head options’ Tab of Create Nesting Job dialog box

Part Data Tab

1. Click on *Part Data* tab.
The solid parts *Tutorial_1a.SLDPRT* and *Tutorial_1b.SLDPRT* which comprise the assembly are listed in the Part List along with their part parameters.
2. In the **Quantity** column of the *Part List*, set the quantity of *Tutorial_1a.SLDPRT* to **25** and the quantity of *Tutorial_1b.SLDPRT* to **38**. Leave all other default part parameter settings as it is.
3. Assign a **Step Angle** of 90 degrees to both the parts *Tutorial_1a.SLDPRT* and *Tutorial_1b.SLDPRT*.



Create Nesting Job X

Part data **Sheet data** Multi head options Options

Part list : Select parts for nesting

Assembly ▲	Part Name	Thickness	Quantity	Material	Rotation Type	Angle	Grain Directio
<input checked="" type="checkbox"/>	Tutorial_1 [Te...		1				
<input checked="" type="checkbox"/>	Tutorial_1b [Nes...	0.75mm	38	Chrome Stainle...	Step angle	90	None
<input checked="" type="checkbox"/>	Tutorial_1a [Nes...	0.75mm	25	Chrome Stainle...	Step angle	90	None

Thickness : 0.75mm

Quantity : 25

Grain direction : None

Material : Chrome Stainles

Normal face : CW ASM Face-1

Rotation angle

Step angle 90

Part angle list 45.90

Part size

X : 186.32mm

Y : 248.16mm

Part preview :

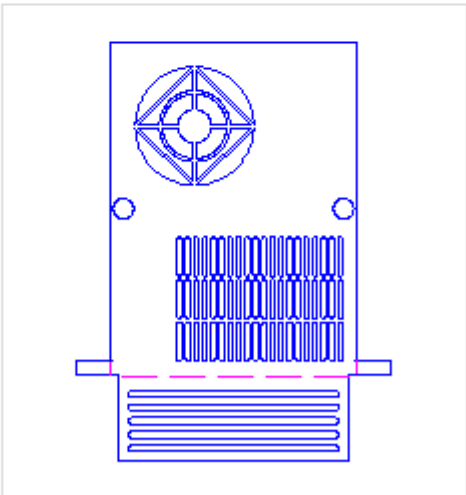

Restore Defaults Preview Nest... Cancel Help

Part Data Tab of 'Create Nesting Job' dialog box

Sheet Data Tab

1. Click on the *Sheet Data* tab.

Observe that the **Thickness and Material** fields display values identical to those of the first part in the part list.

2. To add a sheet, following are the steps:

- i. Select *Custom Sheet* in the sheet type dropdown list. The *Length* and *Width* fields will be activated and will display default values as defined in the DefaultValues.ini file.
- ii. Assign a **length of 1200mm** and a **width of 1200 mm**.
- iii. Set the sheet *Quantity* to '1'.
- iv. Click *Add Sheet* to add the sheet to the Sheet List.

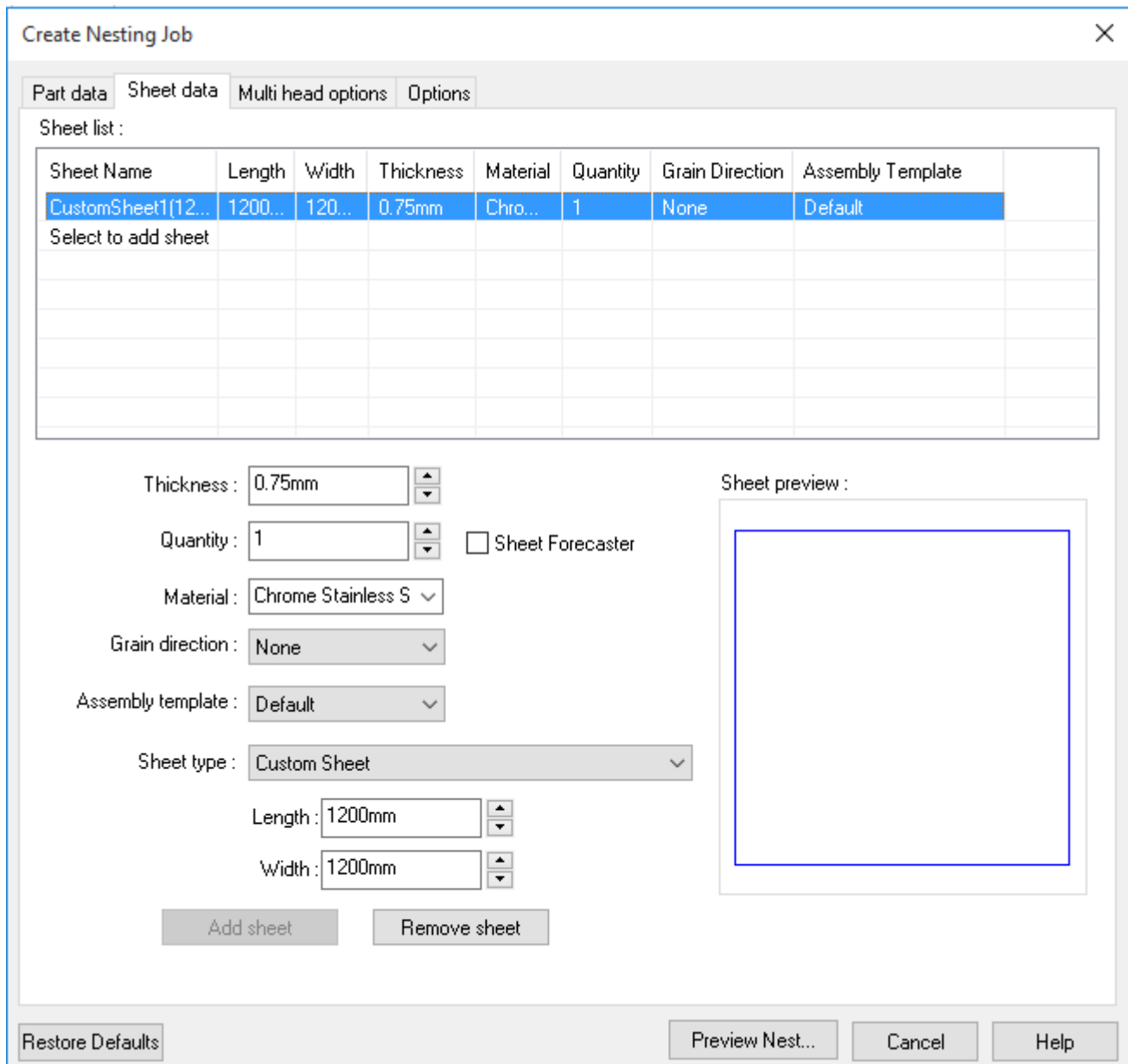

Sheet Data Tab of 'Create Nesting Job' dialog box

Options tab

1. Set a *Part to Part distance* of 2 mm is set and a *Part to Sheet distance* of 3mm.
2. Set the Nesting method to *Optimal nesting*.



Create Nesting Job X

Part data Sheet data Multi head options **Options**

Part to part distance : 2mm

Part to sheet distance : 3mm

Ignore Part Thickness

Align part face with sheet : Top

Assembly Template : C:\ProgramData\SolidWorks\SOLIDWORKS 2018\templates ...

Save output as dxf : C:\ProgramData\NESTINGWorksData\NESTINGWorks 2018x64\Examples ...

Generate Remnants

Type of Remnant : Rectangular

Remnant Output : Sketches in Assembly Create separate remnant assembly

Area constraints :

Constraint type : Constraint By % of Sheet Area

Constraint value : 0.1 %

Width Constraints :

Constraint Type : Constraint By % of Sheet Height

Constraint Value : 0.1 %

Nesting type

Fast nesting Optimal nesting

Max. nesting time : No constraint min

Create separate assembly

Automatically select sheet

Restore Defaults Preview Nest... Cancel Help

Options Tab of 'Create Nesting Job' dialog box

3. Click *Preview Nest...* button to preview the nested layout with available settings in the *Create Nesting Job* dialog box.
4. In the Nesting Preview window, when the result is satisfactory, click on the *Generate Nested Assembly* button to execute the Nesting Process.

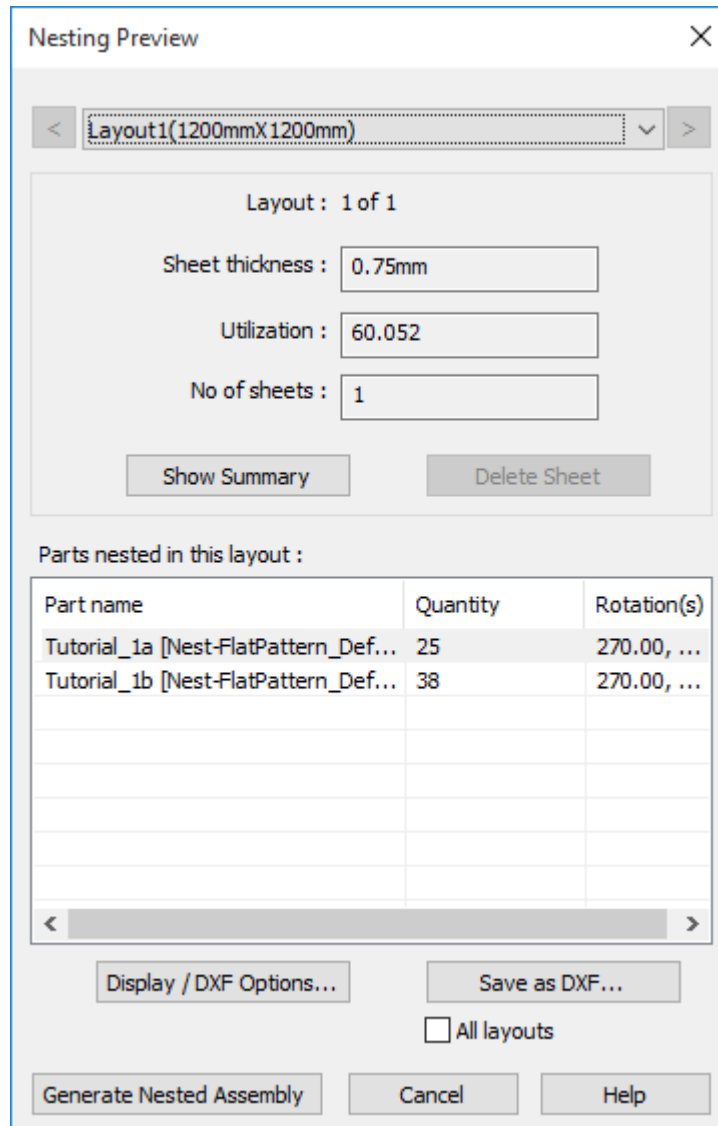

Nesting Preview window

Step 3: Generating the Nested Layout

Summary Text

The Summary text file indicates that the prescribed quantities for all the parts have been nested within the sheet. This summary text file is saved in the same location as the assembly that was nested.

This nested assembly will be saved with the prefix '*NestAssm-*' and suffix '**.ResultsSummary*' added to the name of the assembly file that was nested.



```
NestAssm-Tutorial_1.SLDASM.ResultsSummary - Notepad
File Edit Format View Help
Nest Results Summary
=====
Total Number of Sheets Nested      : 1
Total Number of Part Instances Nested : 63
Overall Utilization                 : 60.051
=====

Nested Part Quantity   Desired Quantity   Part Name
-----
38                     38                     Tutorial_1b [Nest-FlatPattern_Default]
25                     25                     Tutorial_1a [Nest-FlatPattern_Default]
-----

Total no. of Sheets   Parts per Sheet   Sheet Name
-----
1                     63               CustomSheet1(1200mmX1200mm)
-----

Layout Name      : Layout1[Chrome Stainless Steel_0.75mm_Qnty1]
No. of Sheets   : 1
Sheet Name      : CustomSheet1(1200mmX1200mm)
Sheet Length(mm): 1200.00
Sheet Width(mm) : 1200.00
Sheet Thickness(mm) : 0.75
Material        : Chrome Stainless Steel
Sheet Utilization : 60.051

Nested Qty per Sheet   Nested Qty per layout   Total Nested Qty   Part Name
-----
38                     38                     38                 Tutorial_1b [Nest-FlatPattern_Default]
25                     25                     25                 Tutorial_1a [Nest-FlatPattern_Default]
-----
=====
```

Nesting Results Summary Text File

Nested Assembly

The nested layout assembly generated after executing the nesting job and the Summary Results file are stored in the same location as the assembly file that was nested. This nested assembly will be saved with the prefix **'NestAssm-'** added to the name of the assembly file that was nested.

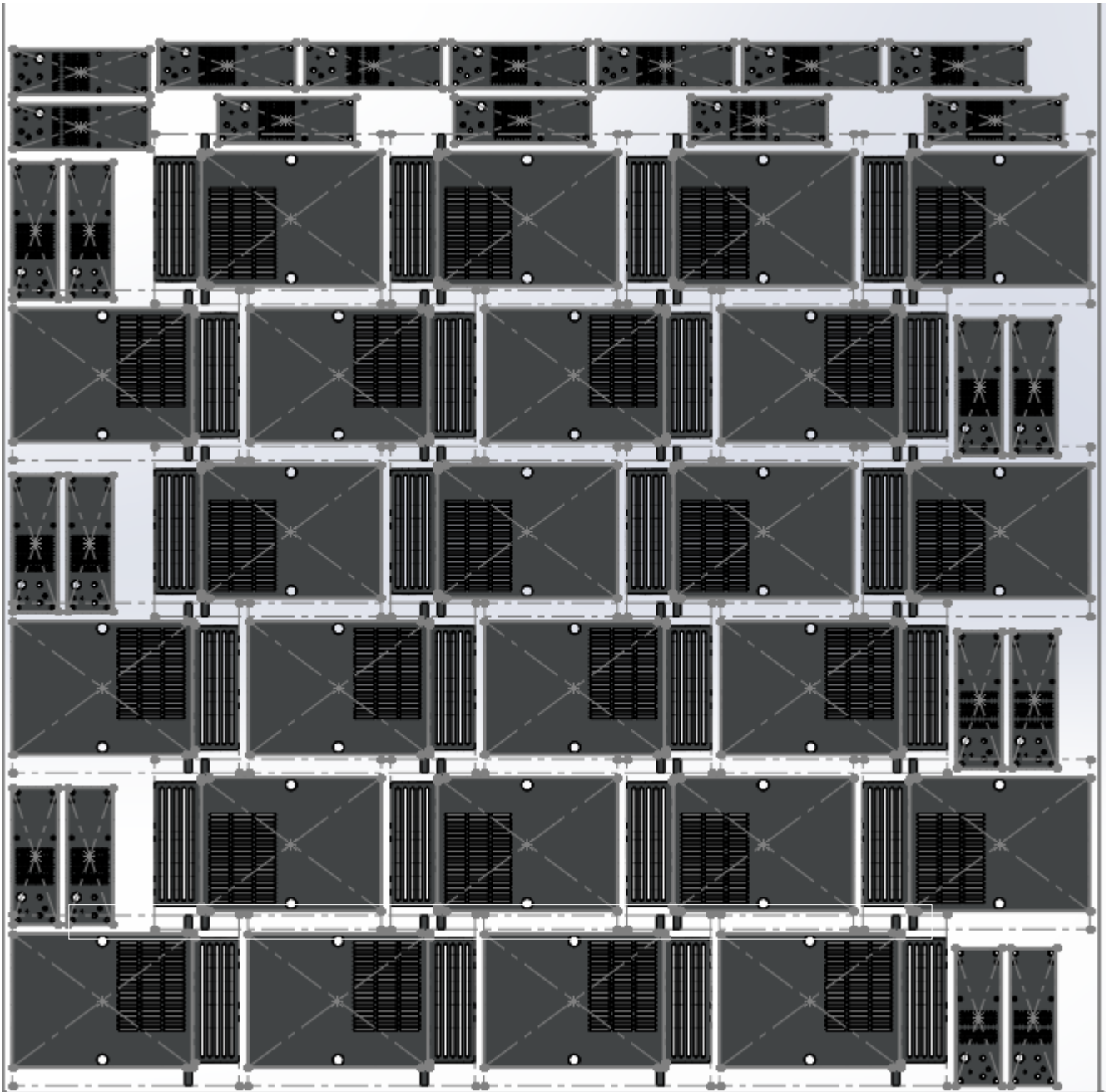

Nested Layout of Assembly achieved with Optimal Nesting

SECTION TWO
NESTINGWorks
Tutorials



TUTORIAL 2- SINGLE PART, SINGLE SHEET NESTING FOR A SOLID PART

Introduction

This tutorial explain is how to nest a solid part in a sheet layout. You will also learn how to nest the part using NESTINGWorks commands that automatically nest multiple instances of the part on a pre-defined sheet and generates a best fit resulting in high sheet utilization and minimal scrap.

Topic covered in this Tutorial:

- Selecting the part to be nested
- Setting part parameters such as Thickness, Quantity, Material, Grain direction and Rotation angle.
- Defining sheet size of type *Standard Size*
- Selecting the *Normal* Direction
- Selecting the output assembly file

STEP 1: Open the Part

1. Load the *NESTINGWorks* Add-In in SOLIDWORKS.
2. Open the part file **Tutorial_2.SLDPRT** in the following folder location.
C:\ProgramData\NESTINGWorksData\NESTINGWorks 201Xx64\Examples\Tutorials\Parts

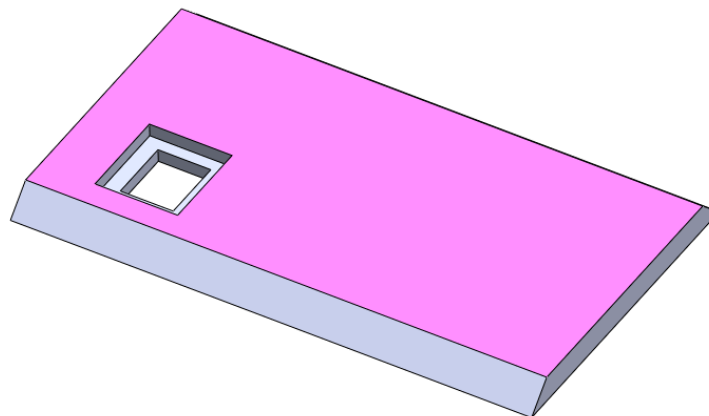

Tutorial_2.SLDPRT



STEP 2: Define the Part Parameters

1. Select *Create Nest Job* from the NESTINGWorks cascading menu.

OR

Click on the *Create Nest Job* button on the NESTINGWorks Ribbon Bar.

The Create Nesting Job dialog box is displayed.

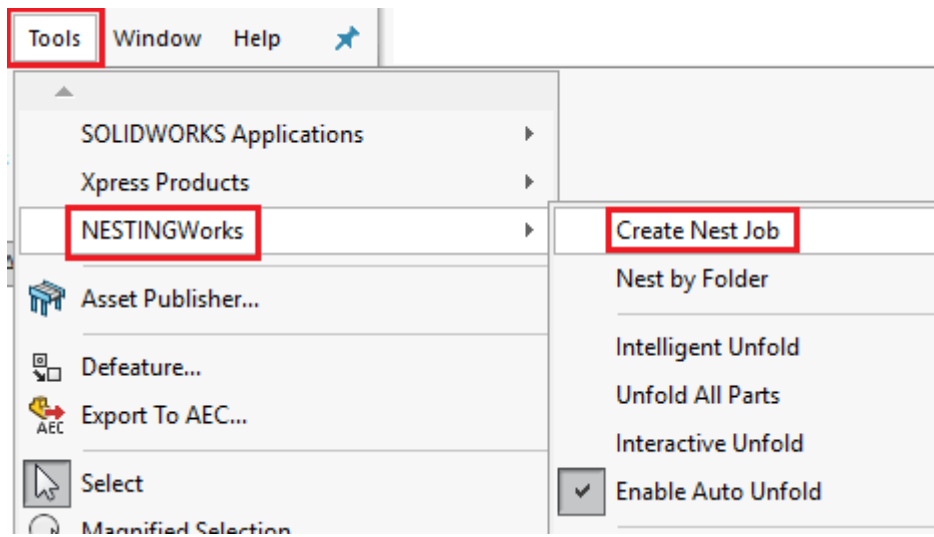

Select 'Create Nest Job' in the NESTINGWorks cascading menu

2. Use the Part data tab of this dialog box to set the parameters for the part.
3. The solid part *Tutorial_2.SLDPRT* is listed in the Part List along with its nesting parameters.
4. Assign the following values to the following Part Parameters:
 - i. **Thickness:**

NESTINGWorks extracts the part parameter of Thickness from the Solid Part and displays it in the Thickness field as default thickness for the part. The thickness of the part, as extracted from the solid part, is displayed as **10mm**.
 - ii. **Material:**

NESTINGWorks extracts the material info from the Solid Part and displays it in the material field. The material for this part, as extracted from the solid part, is *Steel*.
 - iii. **Quantity:**

The default quantity value is displayed in the Quantity field (*As per default value defined in the DefaultValues.ini file explained in NESTINGWorks Configuration Files and Associated Settings Guide*). Double click on the *Quantity* field in the Part list. Set the Part Quantity to **100**.
 - iv. **Angle:**

Double click on the *Angle* column of the *Part List*. Edit and assign an angle of **90 degrees**.
 - v. **Grain Direction:**

Leave the *Grain direction* set to *None*.

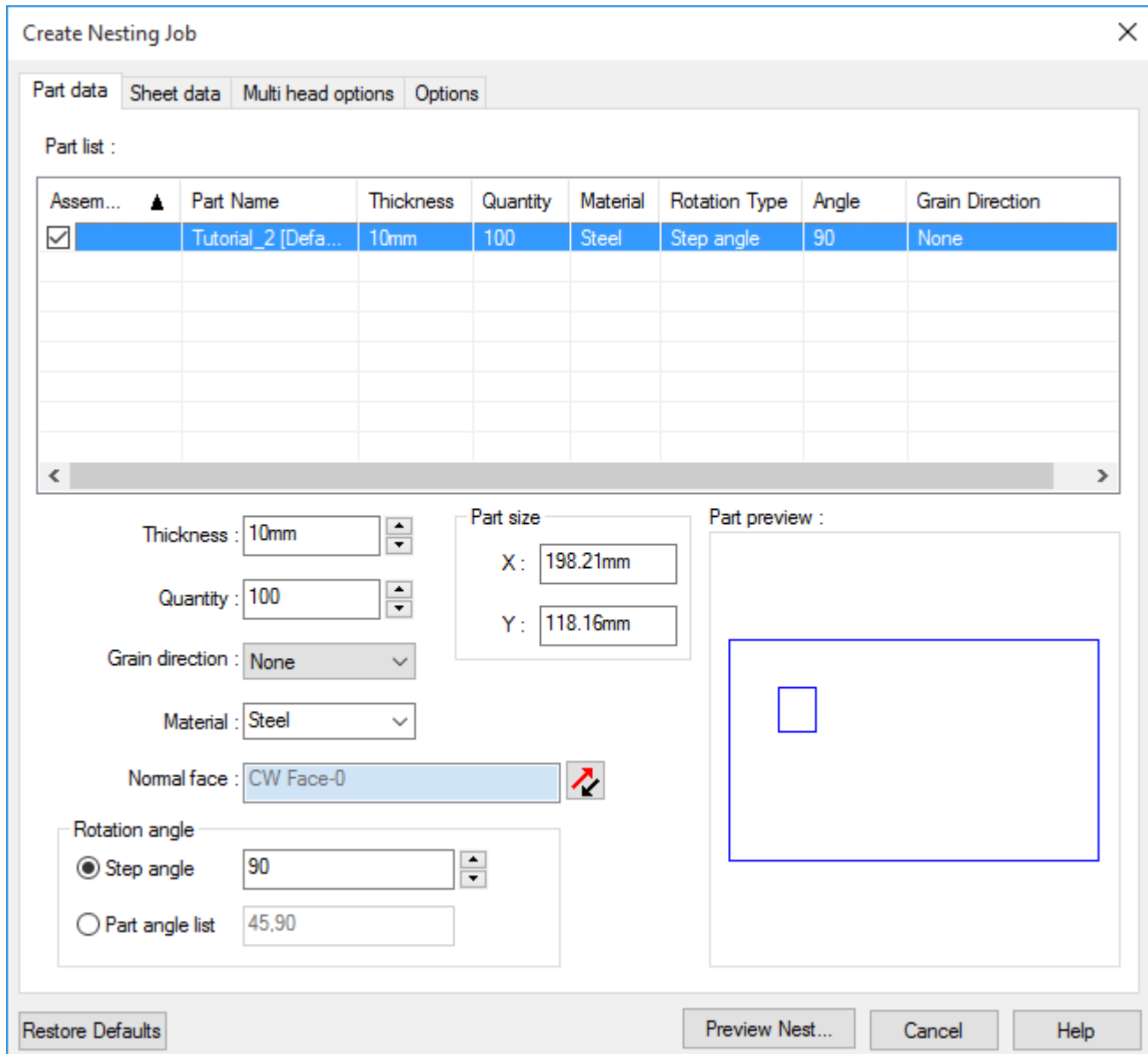

Part data tab in the Create Nesting Job dialog box

vi. **Normal Face:**

By default, NESTINGWorks chooses the face with the largest surface area as the reference plane. So, for the solid part under consideration in this tutorial, the bottom face will be chosen by default as it has the largest surface area. The reference plane will be normal to the machining direction. The normal direction is indicated by an arrow in the graphics area. To choose the top face (indicated by pink color) as the normal face, do either of the following:

- i. Click on the *Reverse* button .
- ii. In the graphics area, click on the top most face of the solid part (face in pink color)
Observe that the arrow indicating the normal direction changes accordingly.

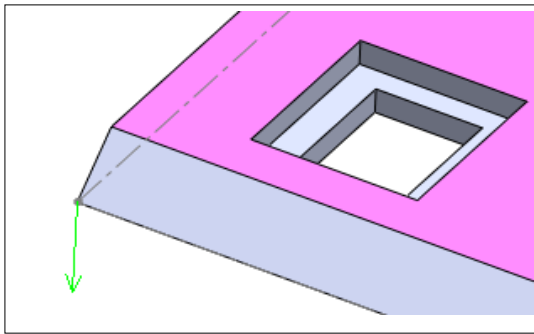

Normal direction when bottom face is selected

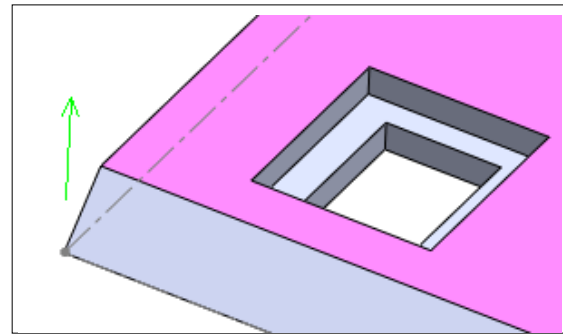

Normal direction when top face is selected

STEP 3: Define the Sheet Parameters & adding a standard sheet

1. Click on the *Sheet Data* tab.

Observe that the assigned thickness and material of the sheet are identical to those of the part to be nested.

2. Set the sheet *Quantity* to '1'.

3. In this tutorial, we will nest the part using a *Standard* sheet type. Click on the *Standard* in the *Sheet type* dropdown list.

Observe the Standard Sheet sizes defined below the Sheet type in the dropdown list.

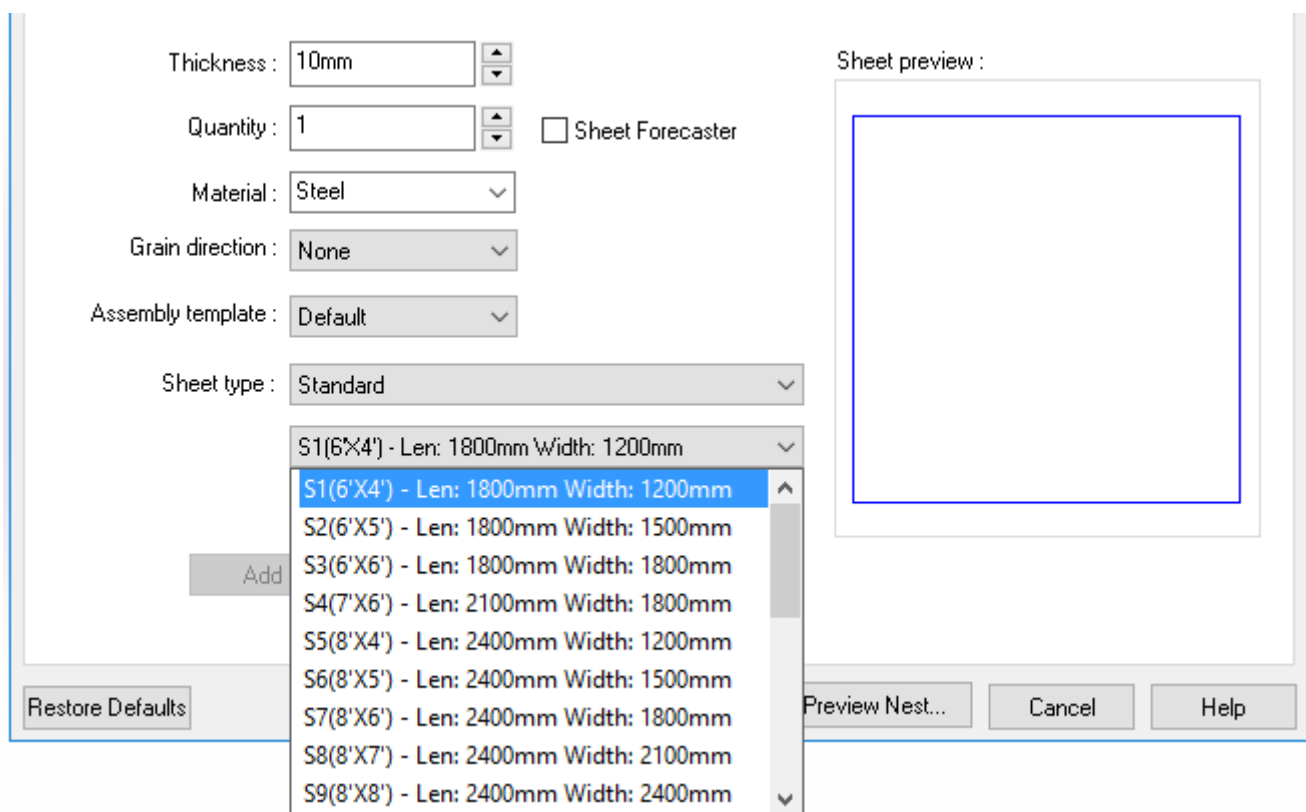

Standard size sheets dropdown list



NESTINGWorks Tutorial

4. Observe that the standard sizes defined in the *Standard Sheets.ini* file are listed in the dropdown list.

In this example, we will choose the second sheet displayed in the list. (with Length = 1800 mm & Width = 1500 mm)

5. Click *Add Sheet* button. The sheet is added to the Sheet list.

Create Nesting Job

Part data Sheet data Multi head options Options

Sheet list :

Sheet Name	Length	Width	Thickness	Material	Quantity	Grain Direction	Assembly Template
StdSheet2-S2(6'X5')	1800mm	1500mm	10mm	Steel	1	None	Default
Select to add sheet							

Selected sheet added to Sheet list

STEP 4: Selecting a machine with Single Tool Head for the Nesting Process

1. Click on the *Multi head options* tab.
2. In the *Machine Data* group box, ensure that the Machine selected is *SingleTHMachine*. The *Number of tool heads* for this machine should be 1.

Create Nesting Job

Part data Sheet data Multi head options Options

Sheet list :

Sheet Name	Length	Width	Thickness	Material	Quantity	Grain Direction	Assembly Template
StdSheet2-S2(6'X5')	1800...	150...	10mm	Steel	1	None	Default

Machine data

Machine: SingleTHMachine

Number of tool heads: 1

Sheet preview :

Selecting *SingleTHMachine* as the machine in the 'Multi head options' tab

Selecting *SingleTHMachine* as the machine ensures the nesting job is executed considering a single tool head and not multiple tool heads.



STEP 5: Define Nesting Parameters

1. Click on the *Options* tab.
2. For this tutorial, set a *Part to Part distance* of **4mm** and a *Part to Sheet distance* of **4mm**.
3. Check the *Save output as dxf* option. Use the  button next to this checkbox to assign the folder location where the nested layouts generated will be saved in the *.dxf* file format.
4. Set the Nesting method to *Fast Nesting*.

Create Nesting Job

Part data | Sheet data | Multi head options | Options

Part to part distance : 4mm

Part to sheet distance : 4mm

Ignore Part Thickness

Align part face with sheet : Default

Assembly Template : C:\ProgramData\SolidWorks\SOLIDWORKS 2018\templates

Save output as dxf : C:\ProgramData\NESTINGWorksData\NESTINGWorks 2018x64\Examples

Generate Remnants

Type of Remnant : Rectangular

Remnant Output : Sketches in Assembly Create separate remnant assembly

Area constraints :

Constraint type : Constraint By % of Sheet Area

Constraint value : 0.1 %

Width Constraints :

Constraint Type : Constraint By % of Sheet Height

Constraint Value : 0.1 %

Nesting type

Fast nesting Optimal nesting

Max. nesting time : min

Create separate assembly

Automatically select sheet

Restore Defaults Preview Nest... Cancel Help

Defining Nesting Parameter values in Options tab of 'Create Nesting Job' dialog box



STEP 6: Generating the Nested Layout

1. Click *Preview Nest...* button to preview the nested layout with available settings in the *Create Nesting Job* dialog box.

Nesting Preview

< Layout1(6'X5') >

Layout : 1 of 1

Sheet thickness : 10mm

Utilization : 84.975

No of sheets : 1

Show Summary Delete Sheet

Parts nested in this layout :

Part name	Quantity	Rotation(s)
Tutorial_2 [Default]	100	0.00, -9...

< >

Display / DXF Options... Save as DXF...

All layouts

Generate Nested Assembly Cancel Help

Nesting Preview dialog box

2. In the Nesting Preview window, when the result is satisfactory, click on the *Generate Nested Assembly* button to execute the Nesting Process.

This sets into motion the process to generate a nested layout.

3. After the Nesting process is completed, NESTINGWorks will display a message indicating the location of the text file containing the **summary of the Nest Results**. Click *OK* to close the message. The Text file will be displayed.



```
NestAssm-Tutorial_2.SLDASM.ResultsSummary - Notepad
File Edit Format View Help
Nest Results Summary
=====
Total Number of Sheets Nested      : 1
Total Number of Part Instances Nested : 1
Overall Utilization                 : 0.850
=====

Nested Part Quantity   Desired Quantity   Part Name
-----
1                      1                  Tutorial_2 [Default]
-----
=====

Total no. of Sheets   Parts per Sheet   Sheet Name
-----
1                     1                  StdSheet1-S2(6'X5')
-----
=====

Layout Name      : Layout1[Steel_10mm_Qnty1]
No. of Sheets   : 1
Sheet Name      : StdSheet1-S2(6'X5')          Sheet Thickness(mm) : 10.00
Sheet Length(mm): 1800.00                      Material             : Steel
Sheet Width(mm) : 1500.00                      Sheet Utilization    : 0.850

Nested Qty per Sheet   Nested Qty per layout   Total Nested Qty   Part Name
-----
1                      1                       1                  Tutorial_2 [Default]
-----
=====
```

Nesting Result Text Summary

4. The **Nested layout assembly** will be displayed in the Graphics area. Both the summary file and the assembly files are saved in the location indicated Output Assembly File path stated in the *Create Nesting Job* dialog box.
5. Browse to the folder location specified for saving the nested layouts in the .dxf format. Observe that the nested layout in .dxf file format is saved in the folder.
6. In this tutorial, we will observe the 3 nesting results:
 - i. Nesting layout generated when top face of the part is chosen as normal face.
 - ii. Nesting layout generated when bottom face of the part is chosen as normal face.
 - iii. Nesting layout when Grain direction is set for part and the sheet.

Result A

Follow all the above steps and view the Nested layout. Observe that all the 100 instances of the part (specified quantity) have been nested.

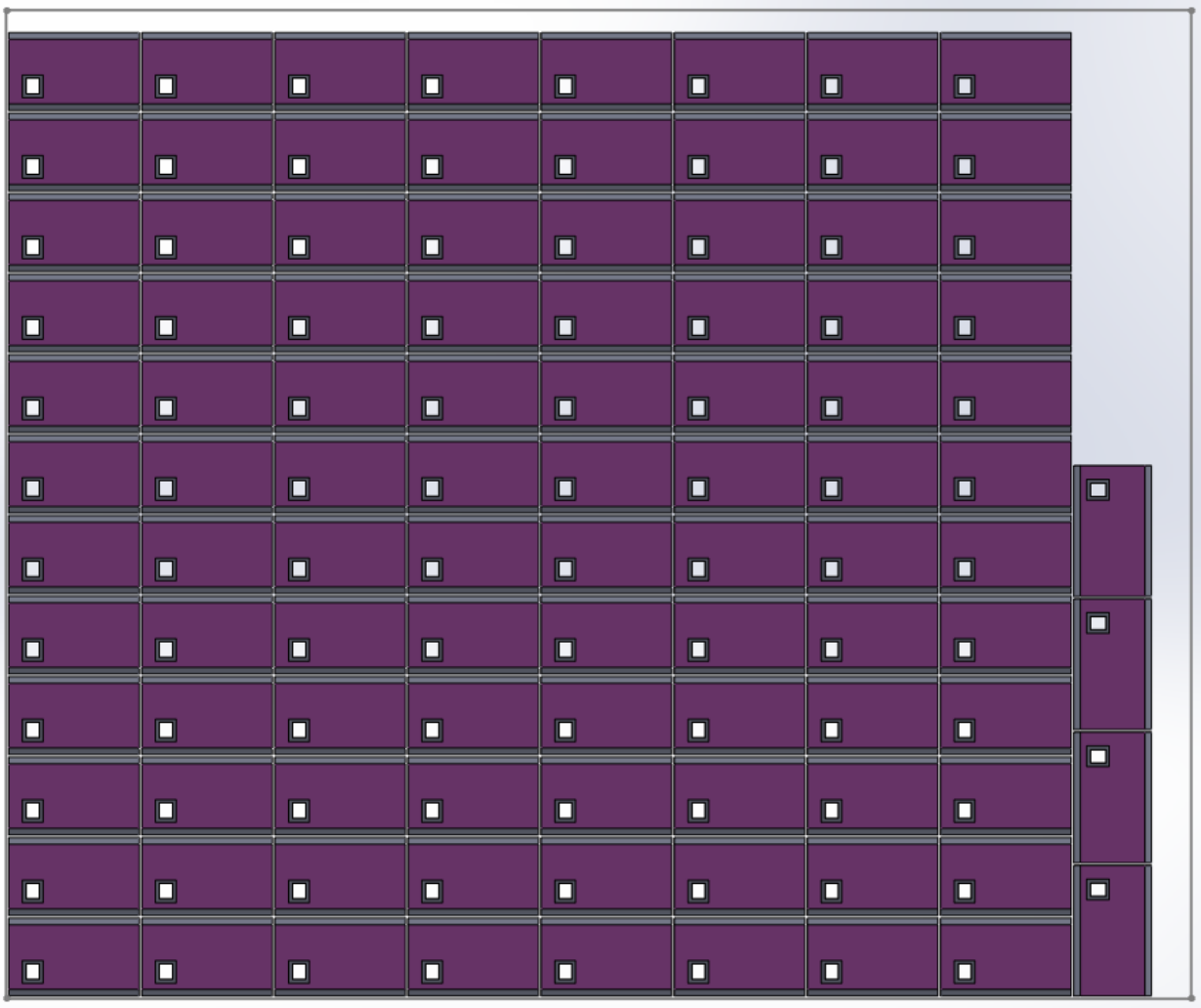

Result A: Nest Result obtained with the top face of the part chosen as normal face

Result B

Repeat all the steps listed in this tutorial without changing the default Normal direction (Step2-4-f). To set the previous normal direction, select the bottom face (gray-colored face) of the part in the graphics area when the *Create Nesting Job* dialog box is displayed and the *Part Data* tab is the active tab. View the nesting layout. Observe that all the 100 instances of the part (specified quantity was 100) have been nested.

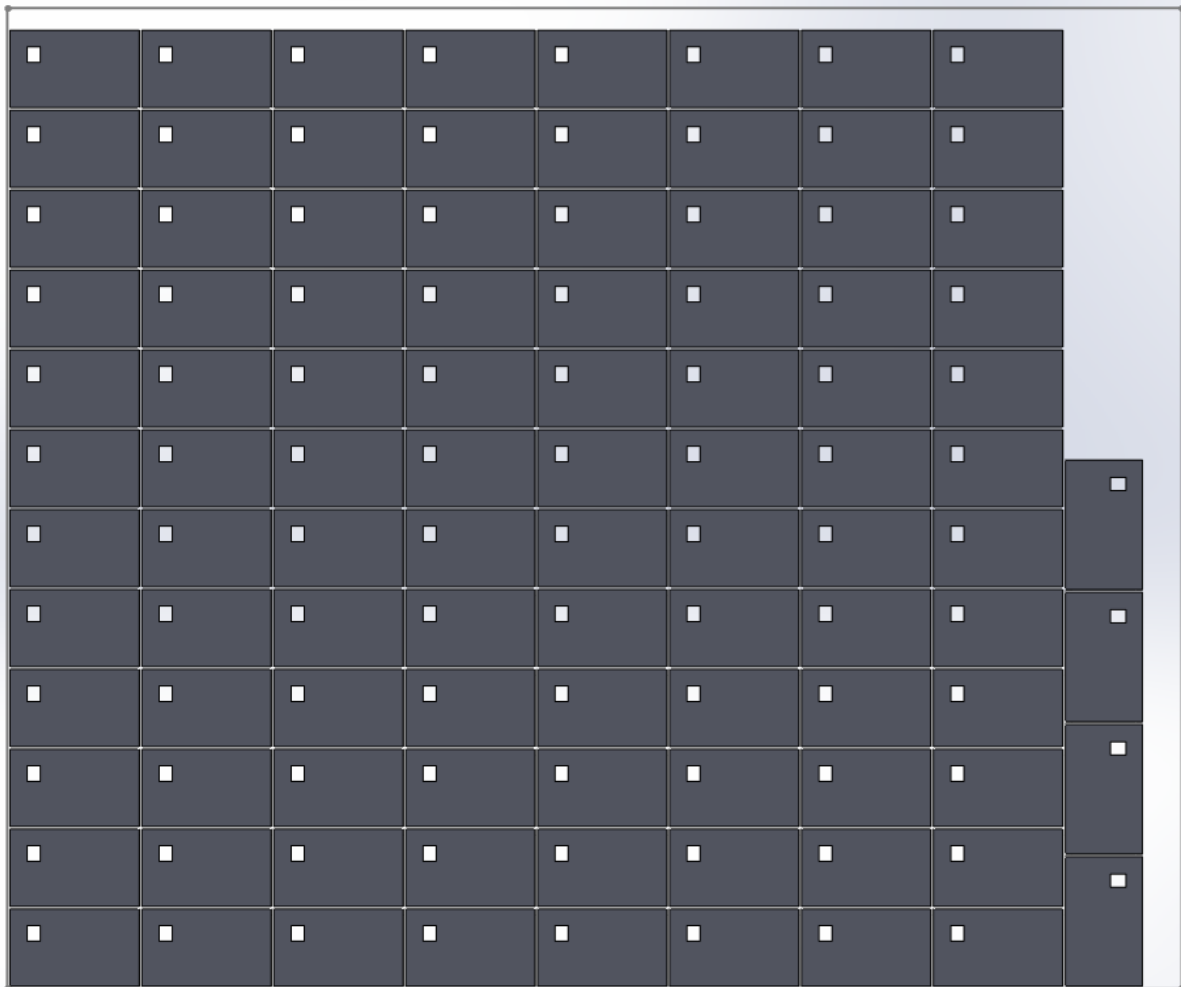

Result B: Nest Result obtained with the bottom face of the part chosen as normal face

Result C

Repeat all the steps listed in this tutorial. However, this time, in Step 2-4-e, set the Grain Direction of the Part to X direction. In the *Sheet Data* tab, set the Grain Direction of the Sheet to X direction. Execute Nesting. View the nesting layout. All the parts are nested along the specified grain direction. Observe that only 96 instances of the part are nested while the quantity specified was 100. The same result will be obtained if the Grain direction of both the part and sheet are set to Y direction.

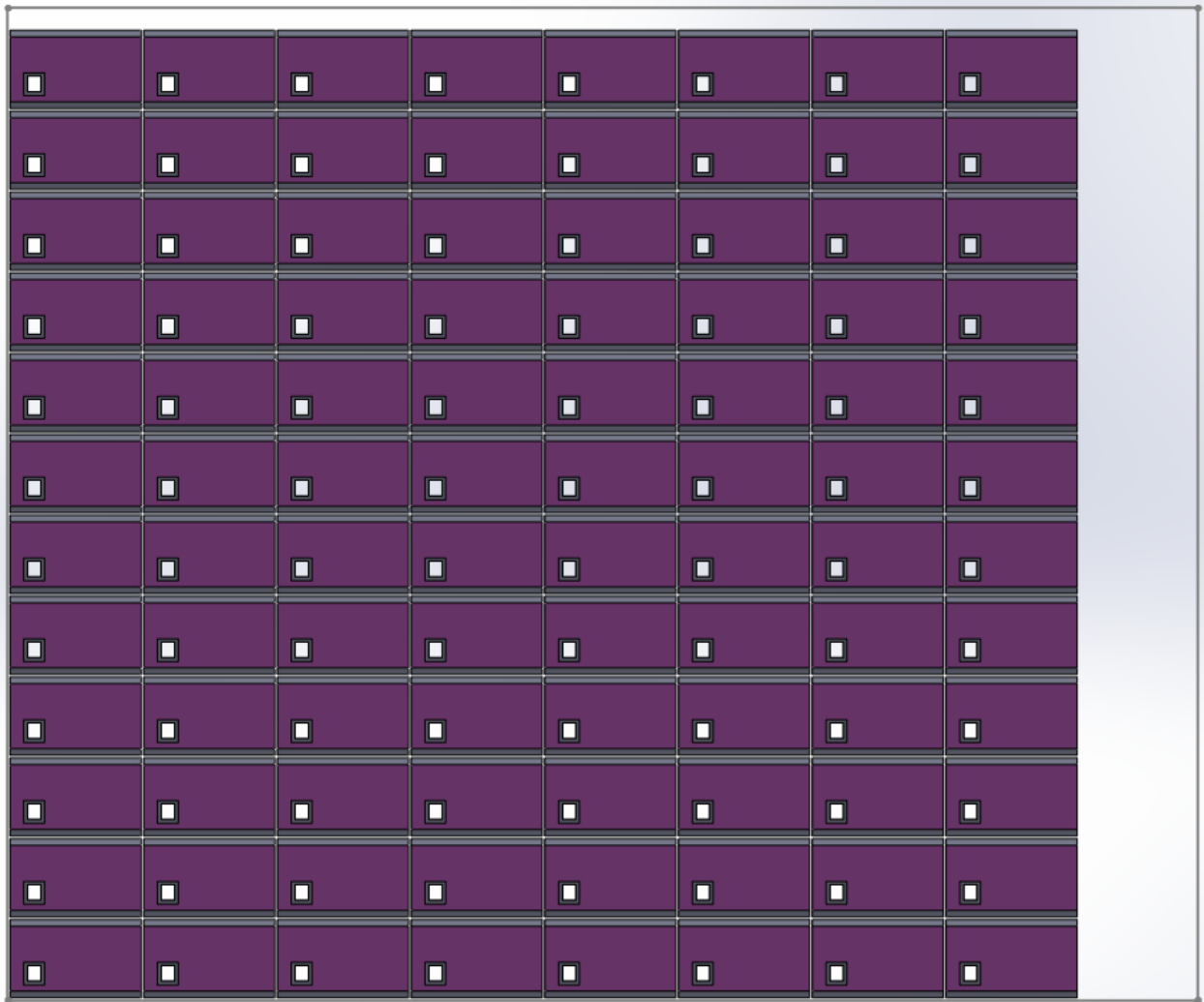

Result C: Nest Result obtained with the top face of the part chosen as normal direction



TUTORIAL 3 – SINGLE PART, SINGLE SHEET **NESTING FOR SHEET METAL PART**

Introduction

This tutorial explains how to nest a sheet metal part in a sheet layout. You will also learn how to nest the part using *NESTINGWorks* commands that automatically nests multiple instances of the part on a pre-defined sheet and generates a best fit resulting in high sheet utilization and minimal scrap.

Topic covered in this Tutorial:

- Selecting the sheet metal part to be nested
- Setting user-defined material for the part.
- Setting the Angle List
- Defining sheet size of type 'Custom Size'

STEP 1: Open the Part

1. Open the part file **Tutorial_3.SLDPRT** in the following folder location.

*C:\ProgramData\NESTINGWorksData\NESTINGWorks 201Xx64\Examples\
Tutorials\Parts*

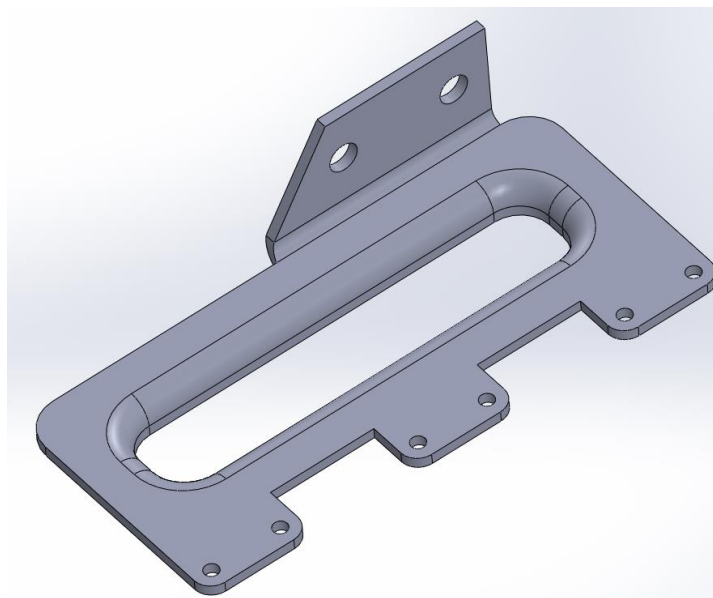

Tutorial_3.SLDPRT



STEP 2: Change in Configuration File settings

Enabling the option to Flatten Sheet Metal Part

In this tutorial, you will nest the sheet metal part based on its dimensions after flattening. The default settings configured in the *DefaultValues.ini* file (explained in *NESTINGWorks Configuration Files and Associated Settings Guide*) ensure that sheet metal parts are flattened before the nesting job is executed. If you are unsure about the settings, open the *DefaultValues.ini* file and set the *FlattenSheetMetalPart* flag to '1' in order to activate the option of flattening.

Enabling the Fix Component Feature of SOLIDWORKS

In the configuration file *DefaultValues.ini* (located within the NESTINGWorks Installation folder), ensure that the flag **FixComponent** under *[NestingData]* section is set to '1'. This setting enables the SOLIDWORKS Fix Component feature which will ensure that after the Nested layouts are generated, the parts in the Nested layout assembly do not get accidentally repositioned.

STEP 3: Define the Part Parameters

1. Select the *Create Nest Job* from the NESTINGWorks Ribbon bar.
The Create Nesting Job dialog box opens.
2. Observe that the sheet metal part *Tutorial_3.SLDPRT* displayed in the graphics area is automatically flattened.

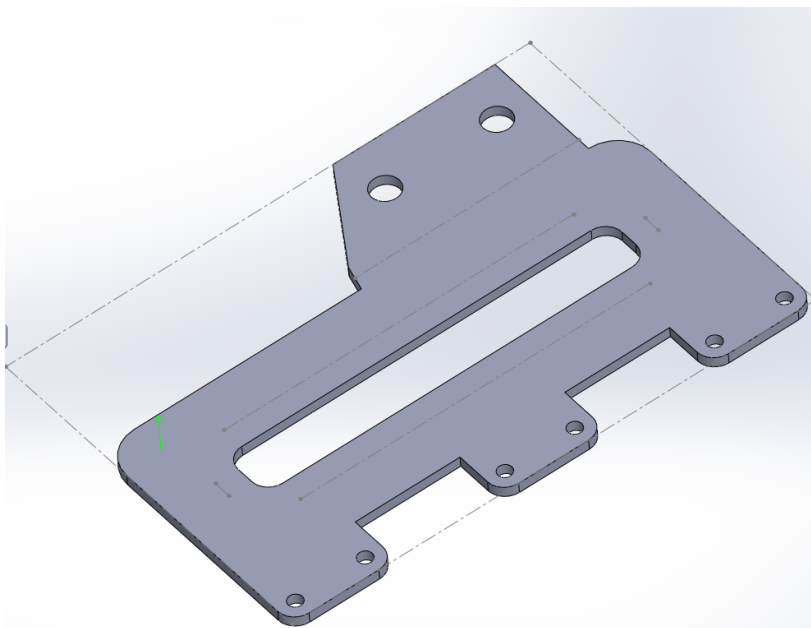

Tutorial_3.SLDPRT after flattening

3. In the Part Data tab, set the following nesting parameters:



- i. **Thickness:** The thickness of the sheet metal part, as extracted from the solid part is **3mm**. In this tutorial, no changes are made to the thickness.
- ii. **Material:** Since Material related information is not defined for this sheet metal part, NESTINGWorks will display the first material (Steel) in the Material drop down list as the default material.
- iii. **Quantity:** Set the Part Quantity to **125**.
- iv. **Angle:** Set a step angle of **90 degrees**.
- v. **Grain Direction:** Leave the Grain direction is set to *None*.
- vi. **Normal Face:** No changes are made to the default normal face selection.

Assembly	Part Name	Thickness	Quantity	Material	Rotation Type	Angle	Grain Direction
<input checked="" type="checkbox"/>	Tutorial_3 [Nest-...	3mm	125	Steel	Step angle	90	None

Thickness : 3mm

Quantity : 125

Grain direction : None

Material : Steel

Normal face : CW Face-1

Rotation angle

Step angle 90

Part angle list 45,90

Part size

X : 104.07mm

Y : 149.91mm

Part preview :

Part Data Tab of 'Create Nesting Job' dialog box



STEP 4: Defining a 'Custom' size sheet

1. Click on the *Sheet Data* tab.
2. Observe that the assigned thickness and material of the sheet are identical to those of the part to be nested.
3. In this tutorial, a custom sheet will be used to nest the parts:
 - i. Select the *Custom Size*.
The Length and Width fields will be activated and will display default values as defined in the DefaultValues.ini file.
 - ii. Assign a length of **1500mm** and a width of **1200mm**.
 - iii. Set the Sheet quantity to 1.
 - iv. Some intelligence is added in NESTINGWorks such that it ensures the sheets with relevant **material and thickness** is available for nesting the part. NESTINGWorks automatically extracts the thickness and material of the first part in the part list and assigns these as the default value of the first sheet. Observe that the material field displays *Steel* and thickness field displays *3mm*.
 - v. Click *Add Sheet* to add the sheet to the *Sheet List*.
 - vi. In the sheet List, the Sheet name of the added Custom Sheet can be changed as required by double-clicking on the sheet name in the sheet list.
 - vii. Assign a new name *Custom(1500x1200)*.

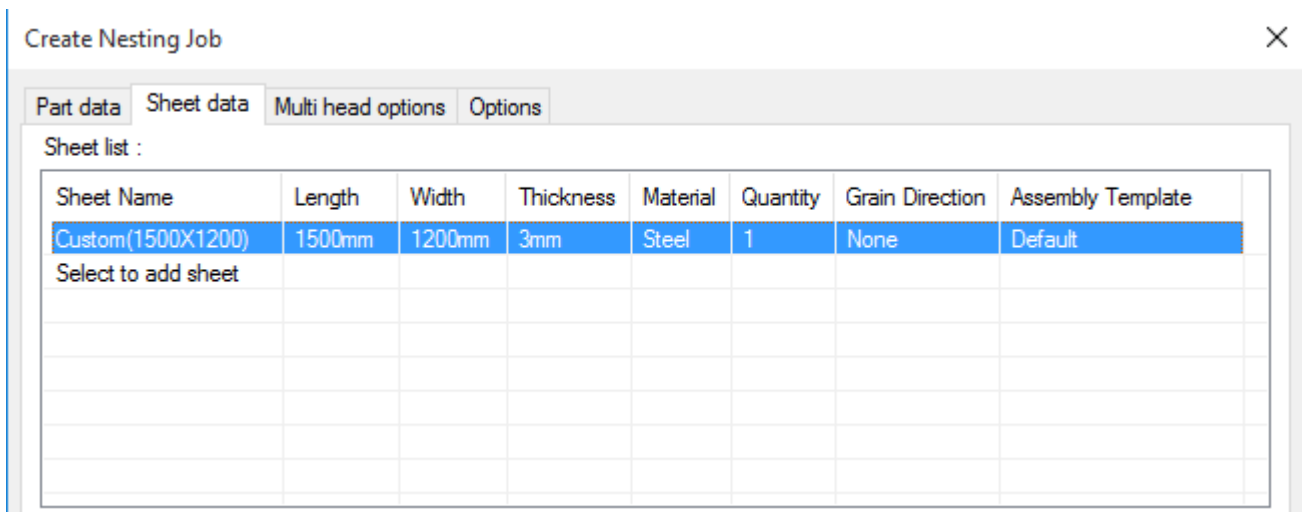

Defining a Custom Size Sheet in Sheet data tab of 'Create Nesting Job' dialog box

STEP 5: Selecting a machine with Single Tool Head for the Nesting Process

1. Click on the *Multi head options* tab.
2. In the *Machine Data* group box, ensure that the Machine selected is *SingleTHMachine*. The *Number of tool heads* for this machine should be 1.
Selecting *SingleTHMachine* as the machine ensures the nesting job is executed considering a single tool head and not multiple tool heads.



Create Nesting Job ×

Part data Sheet data Multi head options Options

Sheet list :

Sheet Name	Length	Width	Thickness	Material	Quantity	Grain Direction	Assembly Template
Custom(1500X12...	1500...	120...	3mm	Steel	1	None	Default

Machine data

Machine: SingleTHMachine

Number of tool heads: 1

Sheet preview :

Multi head options Tab of 'Create Nesting Job' dialog box

STEP 6: Define Nesting Parameters and Generating Layout

1. Click on the *Options* tab.
2. Set a *Part to Part distance* of **3mm** and a *Part to Sheet distance* of **2mm**.
3. Select *Fast Nesting* as the Nesting method.



Create Nesting Job

Part data Sheet data Multi head options Options

Part to part distance : 3mm

Part to sheet distance : 2mm

Ignore Part Thickness

Align part face with sheet : Default

Assembly Template : C:\ProgramData\SolidWorks\SolidWorks 2009\templates

Save output as dxf : C:\ProgramData\NESTINGWorksData\NESTINGWorks 2018x64\Examples

Generate Remnants

Type of Remnant : Rectangular

Remnant Output : Sketches in Assembly Create separate remnant assembly

Area constraints :

Constraint type : Constraint By Value

Constraint value : 0 mm²

Width Constraints :

Constraint Type : Constraint By Value

Constraint Value : 0 mm

Nesting type

Fast nesting Optimal nesting

Max. nesting time : min

Create separate assembly

Automatically select sheet

Restore Defaults Preview Nest... Cancel Help

Options Tab of 'Create Nesting Job' dialog box

4. Click *Preview Nest...* button to preview the nested layout.
5. In the Nesting Preview window, when the result is satisfactory, click on the *Generate Nested Assembly* button to execute the Nesting Process.

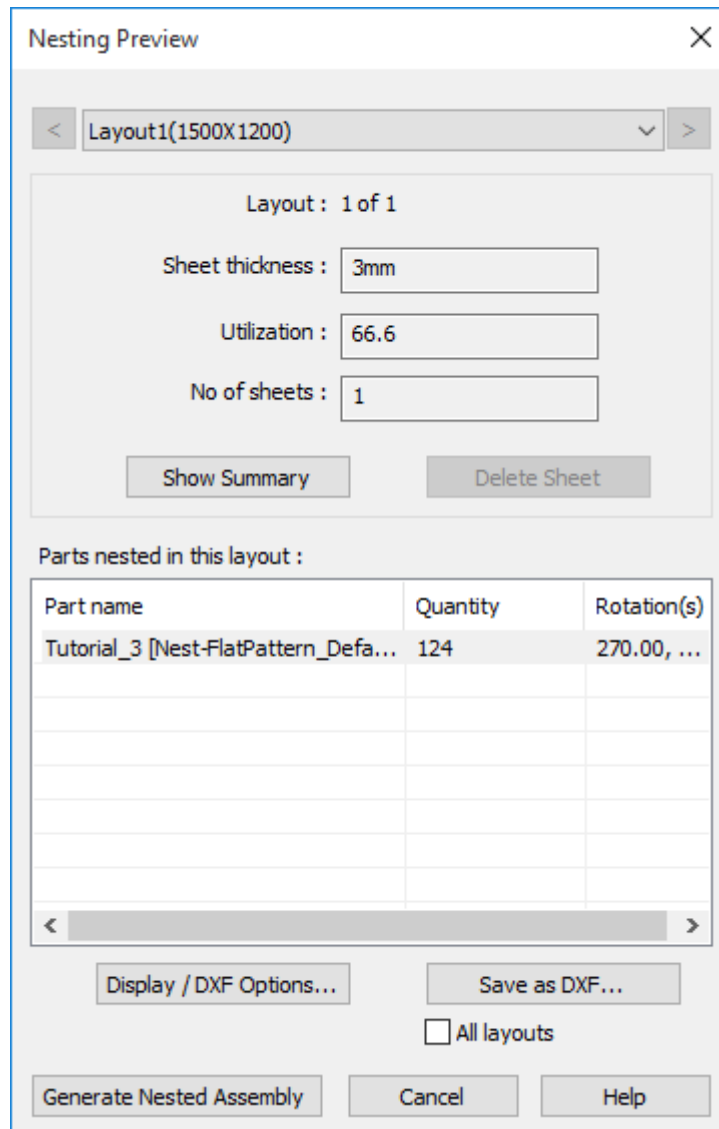

Nesting Preview dialog box

6. Read the Results Summary text file.
It indicates that 124 instances of the part required are nested.



```

NestAssm-Tutorial_3.SLDASM.ResultsSummary - Notepad
File Edit Format View Help
Nest Results Summary
=====
Total Number of Sheets Nested      : 1
Total Number of Part Instances Nested : 124
Overall Utilization                 : 66.600
=====

Nested Part Quantity   Desired Quantity   Part Name
-----
124                    125                Tutorial_3 [Nest-FlatPattern_Default]
-----

Total no. of Sheets    Parts per Sheet    Sheet Name
-----
1                      124                Custom(1500mmX1200mm)
-----

Layout Name      : Layout1[Steel_3mm_Qnty1]
No. of Sheets   : 1
Sheet Name      : Custom(1500mmX1200mm)
Sheet Length(mm): 1500.00
Sheet Width(mm) : 1200.00
Sheet Thickness(mm) : 3.00
Material        : Steel
Sheet Utilization : 66.600

Nested Qty per Sheet   Nested Qty per layout   Total Nested Qty   Part Name
-----
124                    124                    124                Tutorial_3 [Nest-Fla
=====

```

Result Summary text file for Tutorial_3.SLDPRT

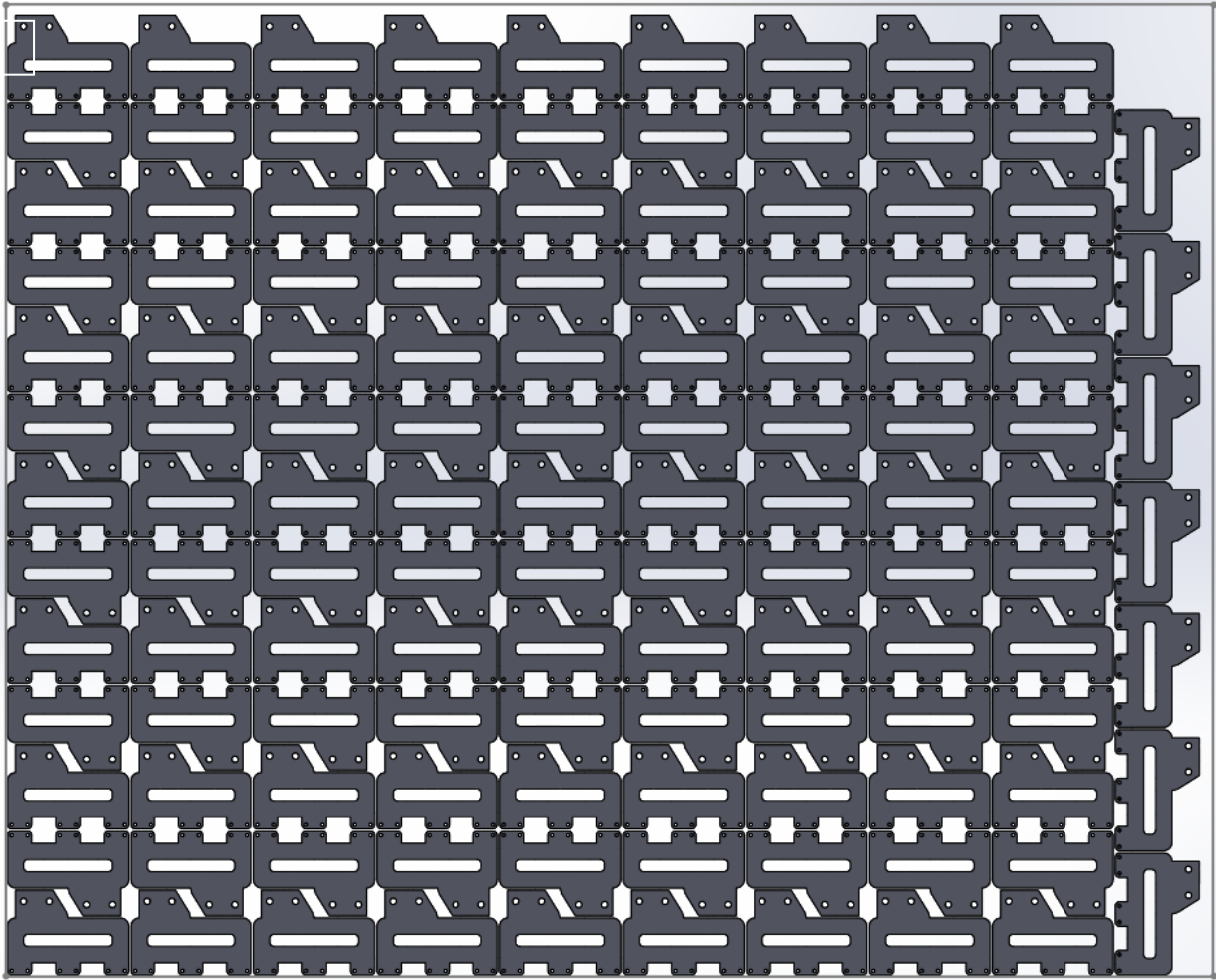

Nesting layout obtained for Tutorial_3.SLDPRT



TUTORIAL 4 – NESTING OF MULTIPLE PARTS BASED ON THICKNESS

Introduction

This tutorial explains how to nest multiple solid parts of varying thicknesses. You will observe how NESTINGWorks generates a multiple layout based on the part thickness in a single Nesting job.

Topic covered in this Tutorial:

- Using the *Nest by Folder* option
- Assembly Nesting of multiple parts
- Selectively nest few parts in the Part List
- Defining a sheet using a DXF file
- Nesting multiple parts of varying thickness on sheets of corresponding thickness
- Nesting of multi-body parts and assemblies containing multi-body parts.

STEP 1: Using ‘Nest by Folder’ to open the Assembly

1. Click on the *Tool* menu and select NESTINGWorks menu in the dropdown list. Select *Nest by Folder* option from the cascading menu.

The *Select a folder* dialog box is displayed.

2. Browse to the folder named *Tutorial4* in the following folder location.

C:\ProgramData\NESTINGWorksData\NESTINGWorks 201Xx64\Examples\Tutorials\Assemblies\Tutorial4

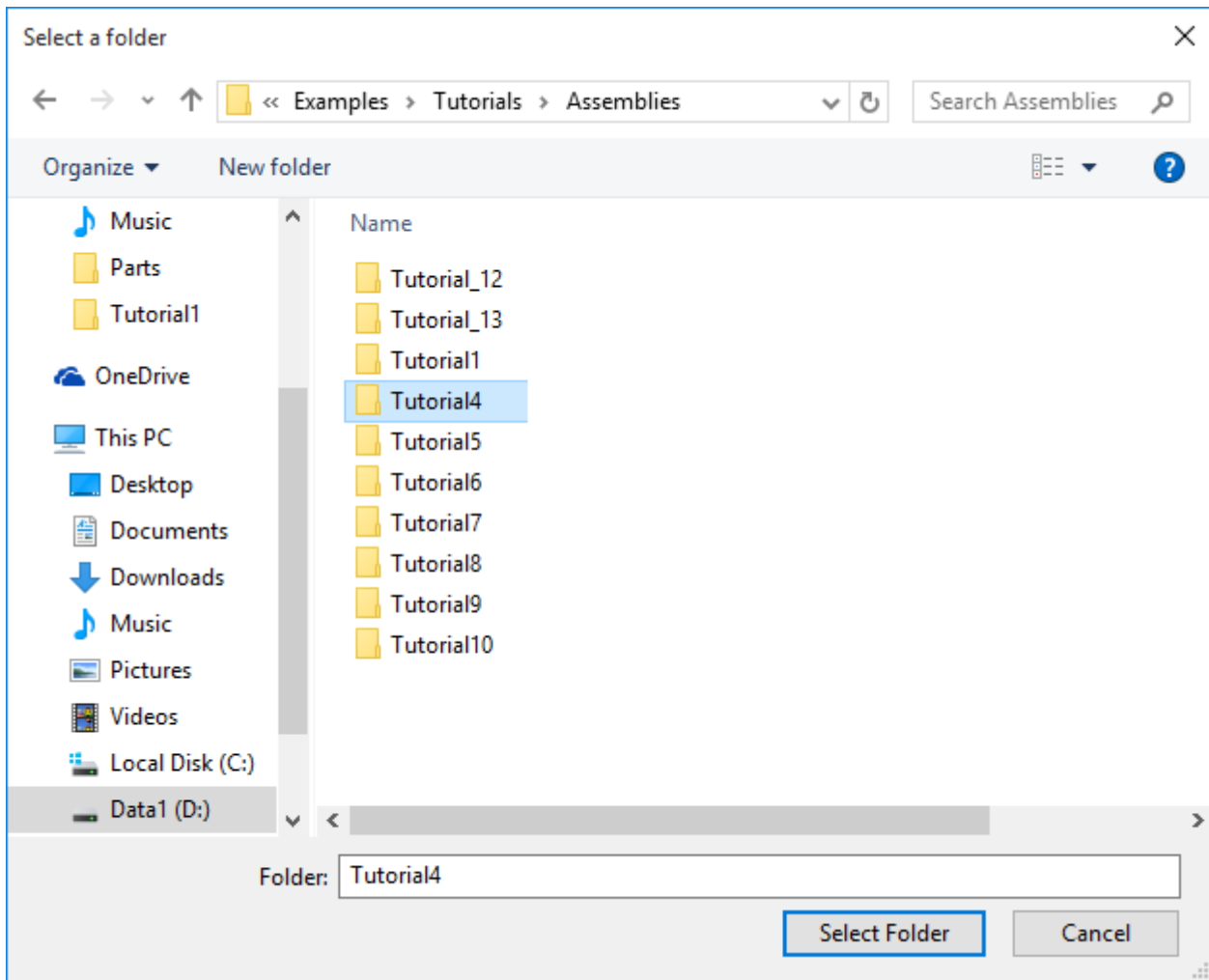

Select a folder' dialog box

3. Click on the *Select Folder* button to open all the parts contained in the folder as an assembly in the SOLIDWORKS Graphics area.
This action will display the *Create Nesting Job* dialog box.
4. All the parts present in the folder are listed in the Part List of the Part data tab.

STEP 2: Define the Part Parameters

In the Create Nesting Job dialog box, observe that thickness of *TutPart4B 20mm.SLDPRT* part is *20mm*.

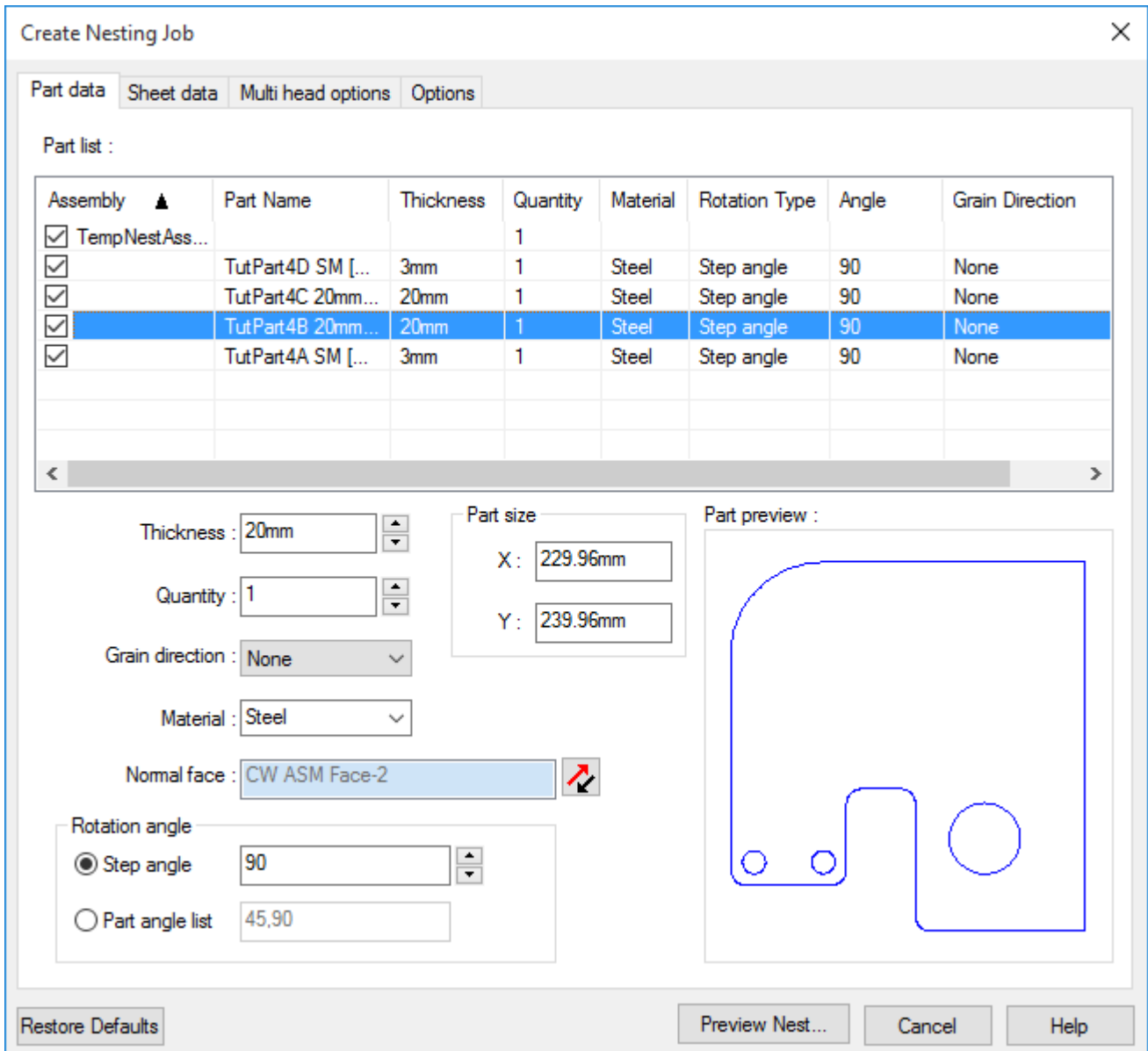

Part Data Tab of 'Create Nesting Job' dialog box

Selectively Nesting Parts

In the *Part data* tab, observe the *Part name* column of the *Part List*. Every listed part has a checkbox to its right which is selected. Such a selected checkbox indicates that the associated part will be taken up for Nesting during the Nesting process. To selectively nest only certain parts in the Part list, deselect the checkbox of those parts which you do not want to nest.

In this tutorial, we will initially nest only the parts **TutPart4A SM** and **TutPart4D SM**. Both of these parts are of same thickness viz. **3mm**. Hence, in the Part list, uncheck the checkboxes given against the parts **TutPart4B 20mm** and **TutPart4C 20mm**.



Create Nesting Job ✕

Part data | Sheet data | Multi head options | Options

Part list :

Assembly ▲	Part Name	Thickness	Quantity	Material	Rotation Type	Angle	Grain Direction
<input checked="" type="checkbox"/>	TempNestAss...		1				
<input checked="" type="checkbox"/>	TutPart4D SM [...]	3mm	62	Steel	Step angle	90	None
<input type="checkbox"/>	TutPart4C 20mm...	20mm	1	Steel	Step angle	90	None
<input type="checkbox"/>	TutPart4B 20mm...	20mm	1	Steel	Step angle	90	None
<input checked="" type="checkbox"/>	TutPart4A SM [...]	3mm	62	Steel	Step angle	90	None

Deselecting parts which are not be nested

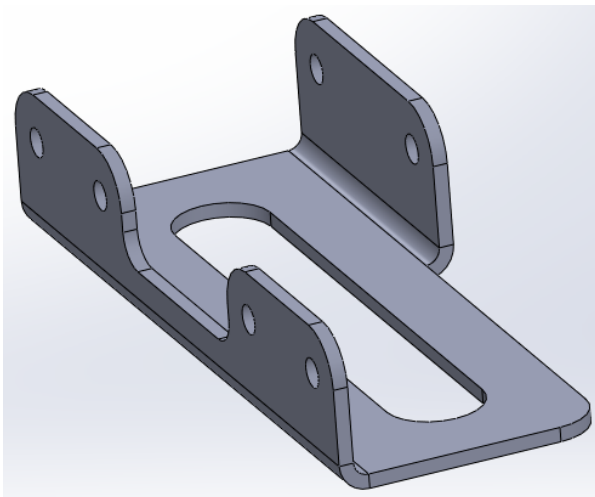

TutPart4A SM.SLDprt

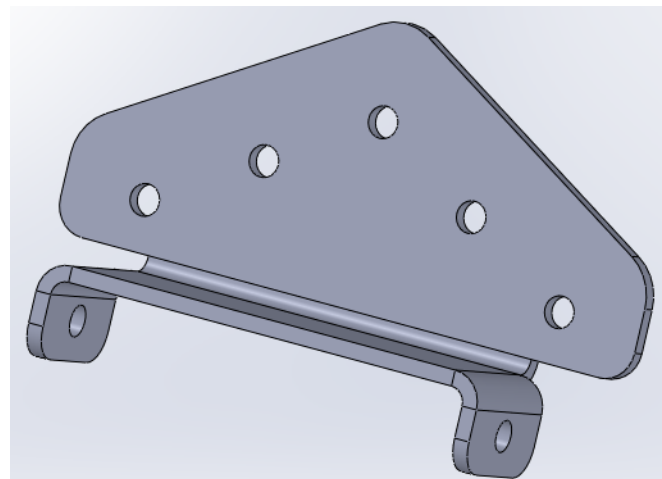

TutPart4D SM.SLDprt

1. Material

Since Material related information is not defined for this sheet metal part, NESTINGWorks will display the first material in the Material drop down list as the default material (Steel). In this tutorial, we will assign a material *Copper* to all the parts. This material is listed in the Material Dropdown list. Select *TutPart4A SM* and *TutPart4D SM* and assign *Copper* from the Material dropdown list.

2. Quantity

Assign a quantity of **62** to both the parts to be nested.

3. Normal Face

No changes are made to the default normal face selection for any of the parts.

4. Grain Direction

Leave the Grain direction set to *None*.

5. Step Angle

Assign a Step Angle of **90 degrees** to all the parts.



STEP 3: Adding a sheet of using 'DXF' file.

In previous tutorials, we learned how to add Standard size and Custom size sheets. In this tutorial, we will use a file in .dxf format to define the sheet.

Following are the steps to define a sheet using a file in .dxf format:

1. Under the *Sheet data* tab, select the option *Sheet DXF*.

This activates the field used to indicate the path of the DXF file.

2. Click on the  button to browse to the folder containing the DXF file.
3. Select the .dxf format file named 'Tutorial4_sheet.dxf' from following location.

C:\ProgramData\NESTINGWorksData\NESTINGWorks 201Xx64\Examples\Tutorials\Sheets

4. NESTINGWorks populates the thickness and material field for each prospective sheet to be added to the sheet list based on the serial order of the parts listed in the part tab. Hence, by default, the Thickness field and the Material field will display the values of the first selected part listed in the part list.

In this tutorial, the thickness and material of the first part (**3mm** and **Copper** respectively) will be displayed as default values.

5. Makes sure Sheet quantity is set as **1** and Grain direction as *None*.
6. Click *Add sheet* to add the file in .dxf format to the Sheet List.

The file in .dxf format is added to the Sheet List. The Sheet preview indicates that this sheet is a remnant (remainder) sheet.

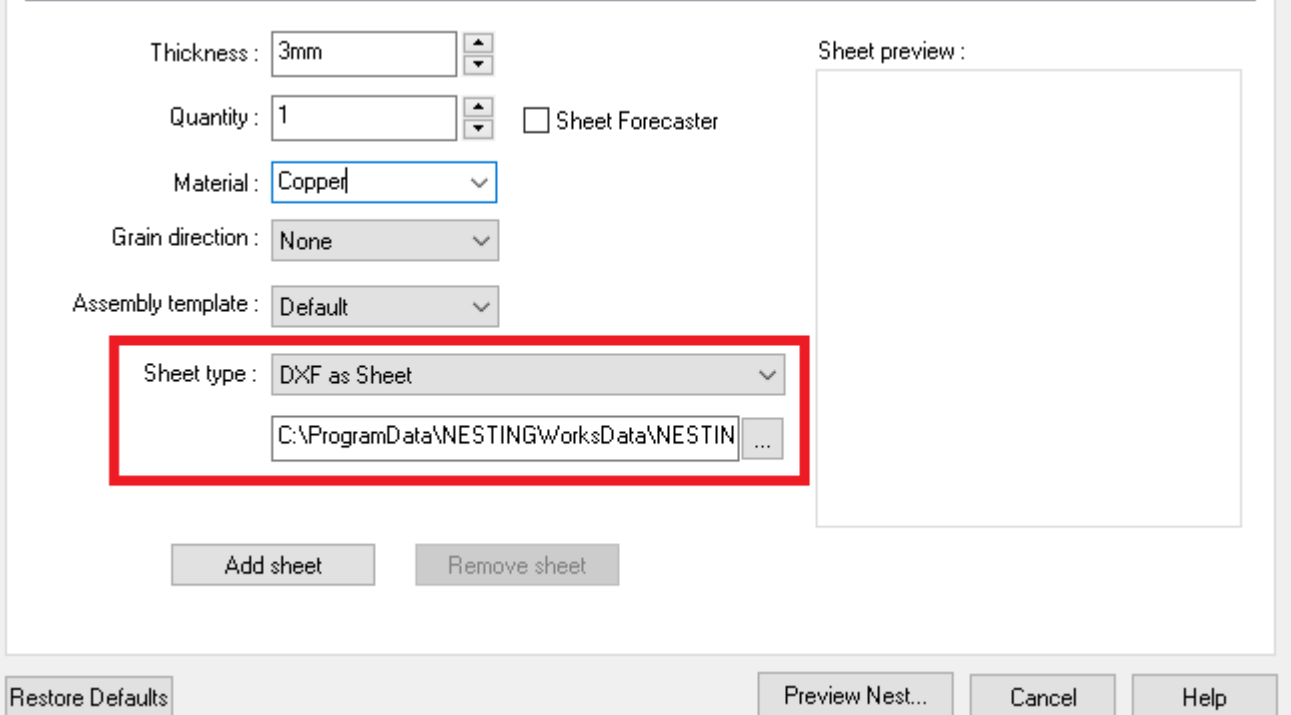

Thickness: 3mm

Quantity: 1 Sheet Forecaster

Material: Copper

Grain direction: None

Assembly template: Default

Sheet type: DXF as Sheet

C:\ProgramData\NESTINGWorksData\NESTINGWorks 201Xx64\Examples\Tutorials\Sheets

Add sheet Remove sheet

Sheet preview :

Restore Defaults Preview Nest... Cancel Help

DXF file added to sheet list on selecting 'Sheet DXF' option



STEP 4: Selecting a machine with Single Tool Head for the Nesting Process

1. Click on the *Multi head options* tab.
2. In the *Machine Data* group box, ensure that the Machine selected is *SingleTHMachine*. The *Number of tool heads* for this machine should be **1**.

Selecting *SingleTHMachine* as the machine ensures the nesting job is executed considering a single tool head and not multiple tool heads.

The screenshot shows the 'Create Nesting Job' dialog box with the 'Multi head options' tab selected. The dialog has four tabs: 'Part data', 'Sheet data', 'Multi head options', and 'Options'. The 'Sheet list' table contains one row with the following data:

Sheet Name	Length	Width	Thickness	Material	Quantity	Grain Direction	Assembly Template
DXFSheet1-Tutori...	0mm	0mm	3mm	Copper	1	None	Default

Below the table, the 'Machine data' group box has 'Machine' set to 'SingleTHMachine' and 'Number of tool heads' set to '1'. The 'Rail direction' group box has radio buttons for 'X' and 'Y', with 'Y' selected. The 'Multi-tool head nesting type' group box has radio buttons for 'Fixed tool head distance' and 'Variable tool head distance', with 'Fixed tool head distance' selected. The 'Tool head distance' group box has a text input field set to '0mm'. To the right, the 'Sheet preview' shows a rectangular sheet with a square and a vertical rectangle nested on it. At the bottom, there are buttons for 'Restore Defaults', 'Preview Nest...', 'Cancel', and 'Help'.

Multi head options Tab of 'Create Nesting Job' dialog box



STEP 5: Define Nesting Parameters

1. Click on the *Options* tab.
2. Set a *Part to Part distance* of **2mm** and a *Part to sheet distance* of **2mm**.
3. Under Nesting type, select *Fast Nesting* as the Nesting method.
4. Click *Preview Nest...* button to preview the nested layout.
5. After satisfactory result obtained, click *Generate Nested Assembly* in the *Nesting Preview* window to execute the nesting process.
6. Observe the Nested layout. The assigned quantities of both parts have been nested.

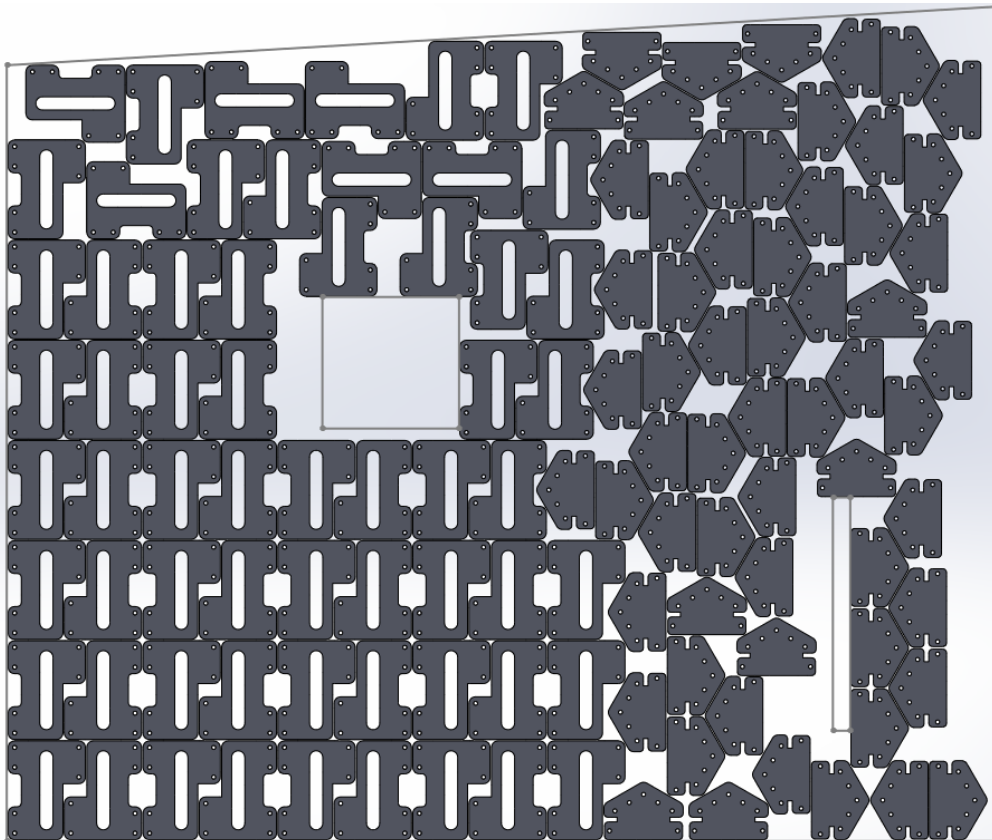

Nested Layout in the DXF sheet

STEP 6: Nesting all the Parts in the Assembly

In the following section, we will learn how to nest parts of varying thickness in a single nesting job.

1. Close the generated assembly file. The four parts are still displayed in the SOLIDWORKS Graphics area.
2. Select *Create Nest Job* from the *NESTINGWorks* Ribbon bar.
The *Create Nesting Job* dialog box is displayed.
3. Observe the *Part list*. Two of the parts viz. **TutPart4A SM** and **TutPart4D SM** are parts of **3mm** thickness each. The other two parts, **TutPart4B 20mm** and **TutPart4C 20mm** are parts of thickness **20mm** each.

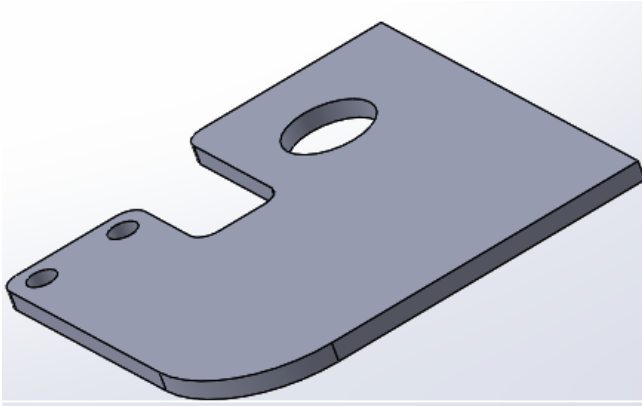

TutPart4B SM.SLDPRT

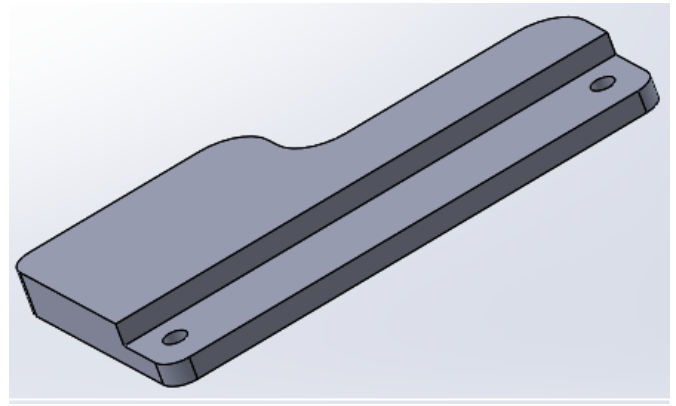

TutPart4C SM.SLDPRT

4. Double click on thickness header in the part list; it automatically arranges the parts based on thickness as shown below. Set the following quantities for the parts displayed in the Part list:

Part Name	Part Quantity	Thickness
TutPart4C 20mm.SLDPRT	20	20mm
TutPart4B 20mm.SLDPRT	30	20mm
TutPart4D SM.SLDPRT	122	3mm
TutPart4A SM.SLDPRT	64	3mm

5. Set the Material, Grain direction, Normal face and Angle with the values as given in [Step 2](#).
6. All the parts now have the same material but, as observed in the above table, two parts have a thickness of 20mm while the other two have a thickness of 3mm. Hence, at least two sheets with a thickness of 20mm and 3mm respectively will be required to nest these parts.

In this tutorial, we will use two standard sheets of size S1 (6' X 4'), each assigned the appropriate thickness to nest these parts.

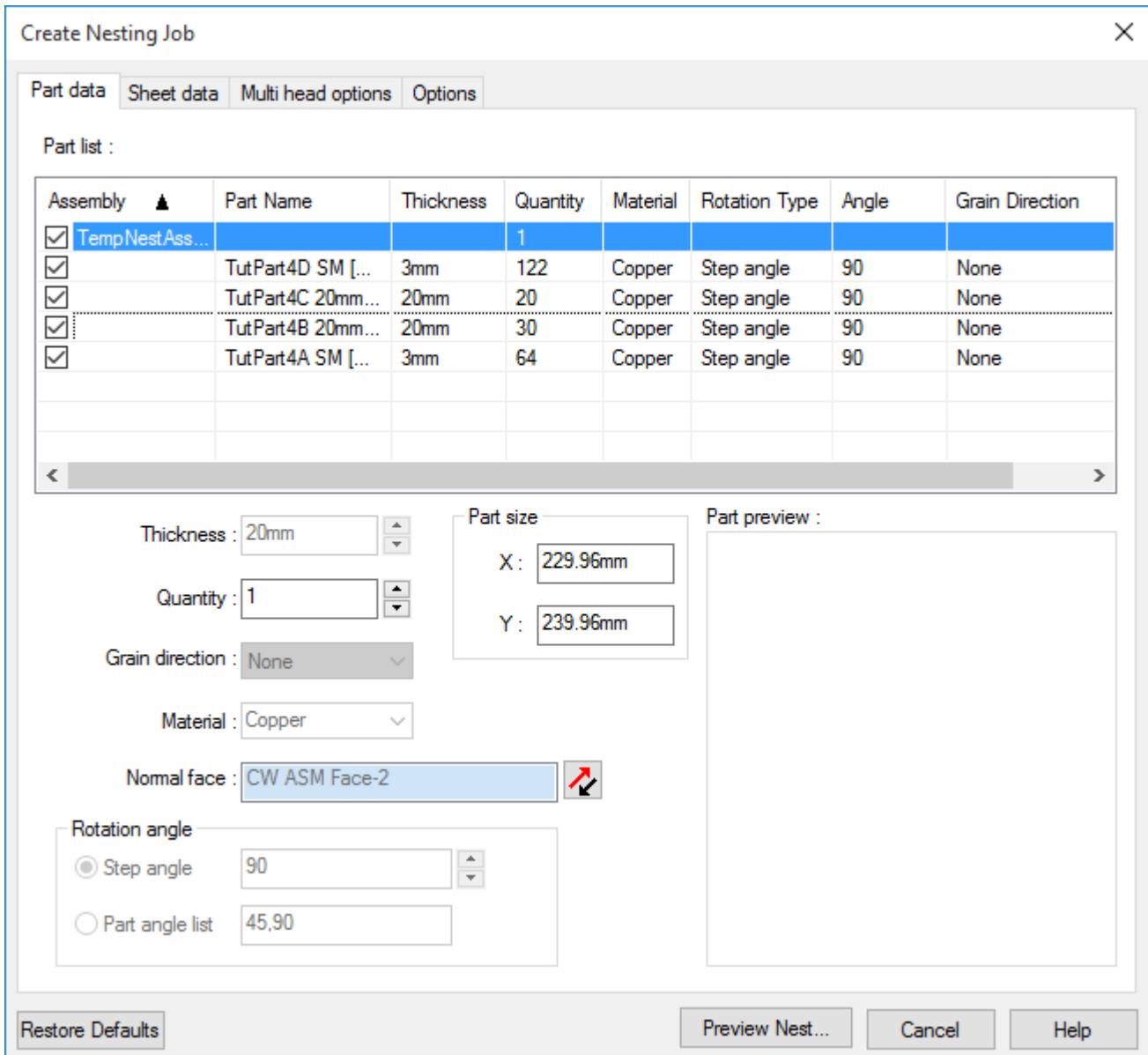

Part Data Tab of 'Create Nesting Job' dialog box

Adding a standard sheet

Following are the steps to add a standard sheet for this tutorial:

1. Click on the *Sheet Data* tab.
2. In the Sheet list, click on *Select to add sheet*.
3. To add a standard sheet, select the *S1 (6' X 4') – Len: 1800 mm Width: 1200 mm* sheet from the Standard Size dropdown List.
4. NESTINGWorks populates the thickness and material field for each sheet to be added to the sheet list based on the serial order of the parts listed in the part tab. Hence, by default, the Thickness field and the Material field will display the values of the first part listed in the part list. In this tutorial, the thickness and material of the first part is **20mm** and *Copper* respectively. In case this value is not displayed in the fields, assign the appropriate values.
5. In the Quantity field, assign a quantity of 1.



6. Leave the Grain Direction set to *None*.
7. Click *Add Sheet* to add the sheet to the Sheet list. The standard sheet is added to the sheet list.
8. Click on *Select to add sheet* in the sheet list.
9. Repeat *step 2* and *3*.
10. This time, as per the principle explained in *step 3*, the Thickness and Material field will display values of the next part in the part list which has either its thickness or material or both different from the previous part. Thus, thickness field will display a value of **3mm** and material field will display *Copper*.
11. Leave the Grain Direction set to *None*.
12. Click *Add Sheet* to add the sheet to the Sheet list.

Sheet Name	Length	Width	Thickness	Material	Quantity	Grain Direction	Assembly Template
StdSheet1-S1(6'X4)	1800mm	1200mm	20mm	Copper	1	None	Default
StdSheet2-S1(6'X4)	1800mm	1200mm	3mm	Copper	1	None	Default
Select to add sheet							

Sheet data Tab of 'Create Nesting Job' dialog box

STEP 7: Defining the Nesting Parameters

1. Click on the *Options* tab.
2. Leave the Part to part distance and Part to sheet distance set to **0mm**.
3. Click *Preview Nest...* button to preview the nested layout.
4. After obtaining the satisfactory result, click *Generate Nested Assembly* in the *Nesting Preview Window* to execute the Nesting process.
5. View the Summary text file. All the parts have been nested as per their assigned quantities.

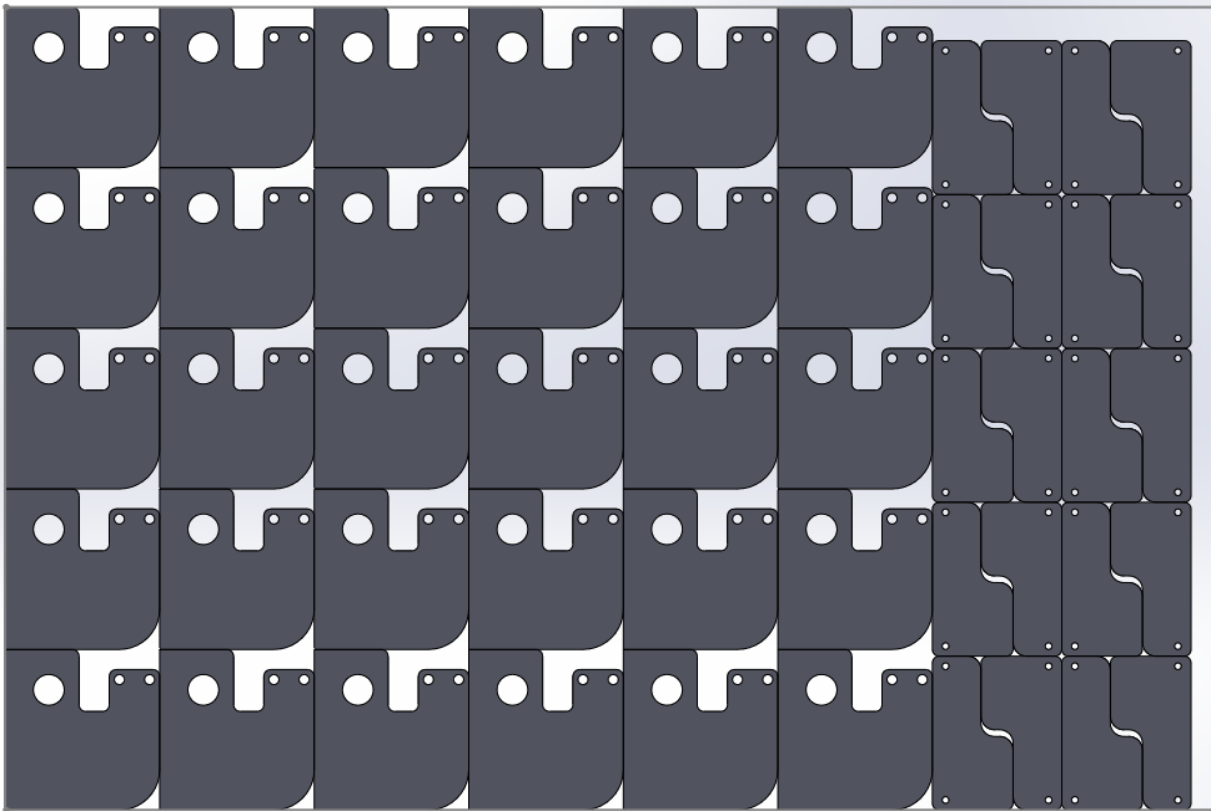

Nested Layout of TutPart4B 20mm and TutPart4C 20mm

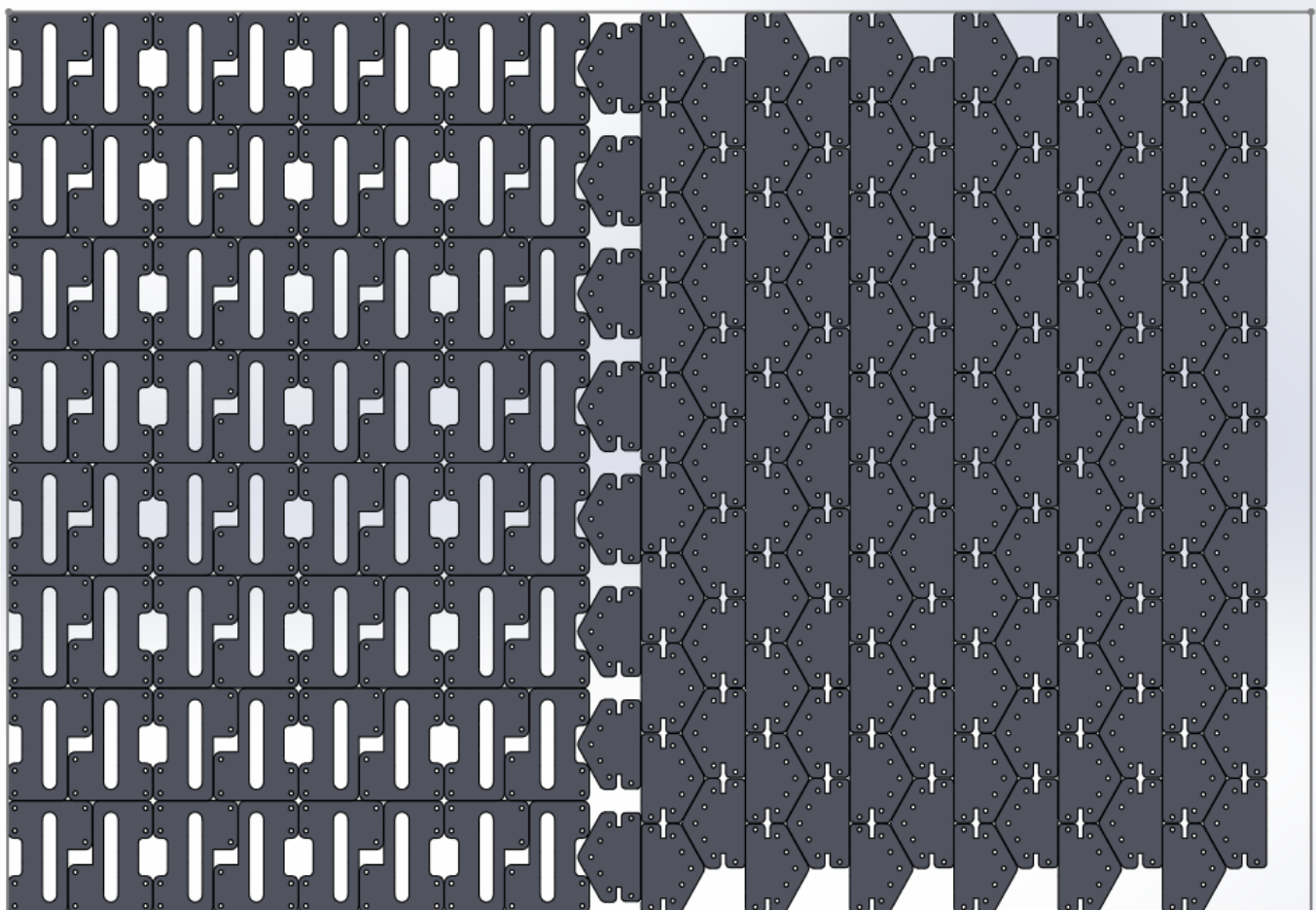

Nested Layout of TutPart4A SM and TutPart4D SM



Nesting of multi-body parts

NESTINGWorks supports nesting of multi-body parts and assemblies containing multi-body parts. However, additional steps must be executed in order to nest such a part or assembly.

NESTINGWorks processes the multi-body part before it can be nested. In order to nest such a part, NESTINGWorks creates and saves each body contained in the multi-body part as a new part. It then proceeds to create an assembly comprising these newly created parts. This newly created assembly becomes the active document considered for the nesting process.

Steps to nest a Multi-body Part

1. Model or open a sheet metal part/ solid part model in SOLIDWORKS.
2. Select *Create Nest Job* from the NESTINGWorks Ribbon bar.
3. NESTINGWorks will check the part for multiple bodies.
4. If the part has multiple bodies, you will be prompted with a message box stating that each body of the part will be saved as a new part and that a new assembly will be created for this multi body part with each body as a separate component.
5. Click *Preview Nest...* button to preview the nested layout.
6. Click *Generate Nested Assembly* in the Nesting Preview window to continue.
7. If you agree to proceed, a new part will be created for each body and will be stored in a new folder located inside the folder containing the parent part (original part with multiple bodies).
8. Suppose the name of the parent part is *PartName*. Then the new folder will be named as *PartName_WithoutMultiBodyParts*. If a folder with such a name already exists, then the newly created folder will be named '**PartName_WithoutMultipleBodyParts1**' and so forth. The new part made out of the first body of the parent part will be named as *PartName_1*; the second body will be named *PartName_2* and so forth. A new assembly named *Assembly.SLDASM* comprising these new parts will be created and saved in the newly created folder.
9. If the folder which contains the parent part does not have write permissions, you will be prompted to choose a folder location to save the newly created parts and to input the name of the new assembly to be created. The parts created out of the parent part with multiple bodies will be saved inside the folder specified by you.
10. The new assembly comprising these parts will be saved inside the same folder with the name input by you.
11. This new assembly comprising parts created out of the parent part will now become the active document considered for nesting process. The single body parts are listed under the Part Data tab of the Create Nesting Job dialog box.
12. Complete the nesting process for this assembly by following the general steps explained in [Tutorial 4](#).



Nesting of assemblies containing multi-body parts

NESTINGWorks supports nesting of multi-body parts and assemblies containing multi-body parts. However, additional steps must be executed in order to nest such a part or assembly.

NESTINGWorks processes the assembly containing multi-body part(s) before it can be nested. Before nesting an assembly, *NESTINGWorks* checks the assembly for parts containing multiple bodies. If multi-body parts are found, *NESTINGWorks* will create a new part out of each body of the multi-body part(s). After this action, either a new assembly containing parts with single bodies will be created or the existing assembly will be modified to with the multiple body part(s) being replaced with the newly created parts. The action executed is based on the choice input by you. The newly created assembly or modified existing assembly becomes the active document considered for the nesting process.

Steps to nest an Assembly containing Multi-body Parts

1. Model or open the Assembly to be nested in SOLIDWORKS.
2. Select the *Create Nest Job* from the *NESTINGWorks* Ribbon bar.
3. *NESTINGWorks* will check the Assembly for parts with multiple bodies.
4. On detecting part(s) with multiple bodies in the assembly, you will be prompted with a message box stating that each body of the part will be saved as a new part and that either a new assembly will be created or the existing assembly will be modified. Click *Yes* to create a new assembly else click *No* to modify the existing assembly.
5. If you click *Yes*, a new assembly containing all parts with single bodies will be created. If you click *No*, the existing assembly will be modified with the multi-body part being replaced with single body parts. (In either assembly, the multi-body part will be removed). Note that in case of modifying the existing assembly, the sub-assemblies (if there are any) will be removed and all parts will have the existing assembly as their immediate parent.
6. Suppose the name of the existing assembly to be nested is XYZ.SLDASM and it contains two multi-body parts, say 'X' and 'Y' and a single body part named 'Z'. Then *NESTINGWorks* creates new parts out the multi-body parts and either generates the new assembly or modifies the existing assembly in the following manner:
 - A new folder named *XYZ_WithoutMultiBodyParts* is created within the folder where the existing assembly is located.
 - The new parts created out of the multiple bodies of part 'X' will be named *X_1*, *X_2* and so on and these parts will be saved in this *XYZ_WithoutMultiBodyParts* folder.
 - Similarly, the new parts created out of the multiple bodies of part 'Y' will be named *Y_1*, *Y_2* and so on and these parts will also be saved in the same folder.
 - The single body part named 'Z' too will be copied into this newly created folder.
 - If you selected *Yes* (i.e. you chose to create a new assembly with single body parts), then this newly created assembly will be named *Assembly.SLDASM* and this file too will be saved in the *XYZ_WithoutMultiBodyParts* folder. This new assembly file will comprise of all new parts (*X_1*, *X_2* etc.; *Y_1*, *Y_2*, etc.) created out the original multi-body parts as well as the single-body parts (Z).



- If you selected *No* (i.e. you chose to modify the existing assembly [XYZ.SLDASM]), then the existing assembly will be modified to now contain parts saved within the *XYZ_WithoutMultiBodyParts* folder. Effectively, the original multi-body parts will be replaced with their corresponding parts created out of the multiple bodies.
7. Thus the newly created assembly or modified existing assembly containing single body parts will become the active document considered for nesting process. The single body parts are listed under the Part Data tab of the Create Nesting Job dialog box.
 8. Complete the nesting process for this assembly by following the general steps explained in [Tutorial 4](#).



TUTORIAL 5 – NEST BY MATERIAL, NEST BY THICKNESS

Introduction

This tutorial explains how to nest multiple solid parts of varying thickness and materials. You will observe how *NESTINGWorks* generates a multiple layout based on the part material and thickness and performs *preferential hole filling*.

Topic covered in this Tutorial:

- Nesting multiple parts of varying thickness and material
- Preferential hole filling
- Viewing the nested layouts on multiple sheets

Preferential Hole Filling

In this tutorial, we will explore preferential hole filling. In one of the sheet layouts, you will observe how a smaller part can be nested in the holes of larger parts resulting in higher sheet utilization and minimal scrap.

STEP 1: Enabling ‘Preferential Hole Filling’ functionality

Since the feature of Preferential Hole Filling will be used in this tutorial, it is imperative that this feature be enabled. The default settings configured in the **DefaultValues.ini** file are configured to keep this feature enabled for all the nesting jobs. If you are unsure about the settings, open the **DefaultValues.ini** file (explained in *NESTINGWorks Configuration Files and Associated Settings Guide*) and set the *PreferHoleFilling* flag to ‘1’ in order to enable the ‘Preferential Hole Filling’ feature.

STEP 2: Using ‘Nest by Folder’ to open the Assembly

1. Click on the *Tool* menu and select *NESTINGWorks* menu in the dropdown list. Select *Nest by Folder* option from the cascading menu.

OR

Click on the *Nest by Folder* button on the *NESTINGWorks* Ribbon Bar.

2. The *Select a folder* dialog box is displayed. Browse to the folder named *Tutorial5* in the following folder location.

C:\ProgramData\NESTINGWorksData\NESTINGWorks 201Xx64\Examples\Tutorials\Assemblies

3. *NESTINGWorks* opens all the parts contained in the folder as an assembly in the *SOLIDWORKS* Graphics area.

The *Create Nesting Job* dialog box is displayed. All the parts present in the assembly are listed in the *Part List* of the *Part data* tab.



- In the *Part list*, click on the column heading *Part Name* to sort the data in ascending order from A to Z.

Create Nesting Job ×

Part data Sheet data Multi head options Options

Part list :

Assembly ▲	Part Name ^	Thickness	Quantity	Material	Rotation Type	Angle	Grain Direction
<input checked="" type="checkbox"/>	TempNestAss...		1				
<input checked="" type="checkbox"/>	Tut5_Part1 [Def...	10mm	1	Alloy ...	Step angle	90	None
<input checked="" type="checkbox"/>	Tut5_Part2 [Def...	12.7mm	1	Steel	Step angle	90	None
<input checked="" type="checkbox"/>	Tut5_Part3 [Def...	12.7mm	1	Steel	Step angle	90	None
<input checked="" type="checkbox"/>	Tut5_Part4 [Nes...	10mm	1	Alloy ...	Step angle	90	None
<input checked="" type="checkbox"/>	Tut5_Part5 [Def...	12.7mm	1	Steel	Step angle	90	None
<input checked="" type="checkbox"/>	Tut5_Part6 [Def...	12.7mm	1	Steel	Step angle	90	None

Parts selected using 'Nest by Folder' command listed in the Part List of 'Part data' tab

STEP 3: Define the Part Parameters

Thickness & Material of the parts

The thickness and material of the solid parts extracted from the solid models is displayed in the Part List.

- The part named *Tut5_Part1* and *Tut5_Part4* have the same material *Alloy Steel (SS)* and Thickness **10mm**.

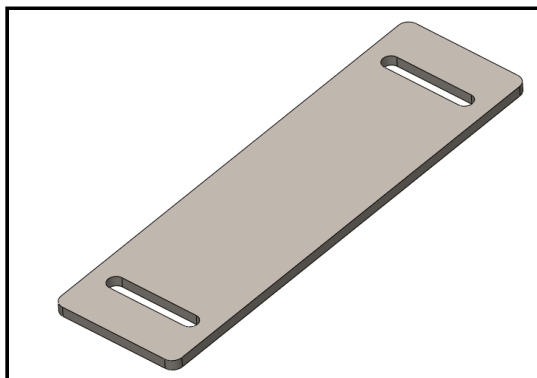

Tut5_Part1.SLDPRT

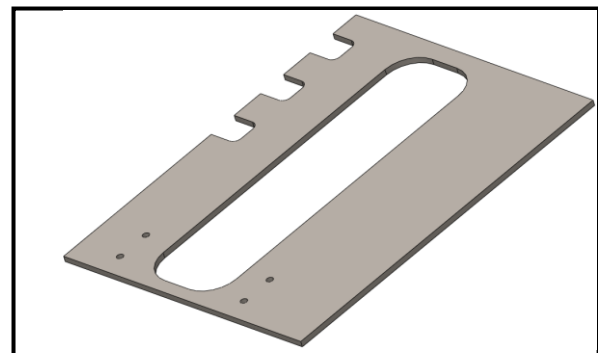

Tut5_Part4.SLDPRT

- The parts *Tut5_Part2*, *Tut5_Part3*, *Tut5_Part5* and *Tut5_Part6* have identical material *Steel* and Thickness **12.7mm**.

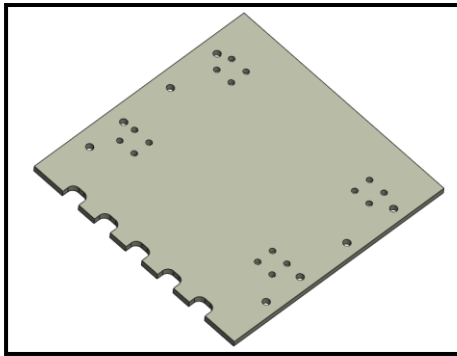

Tut5_Part2.SLDPRT

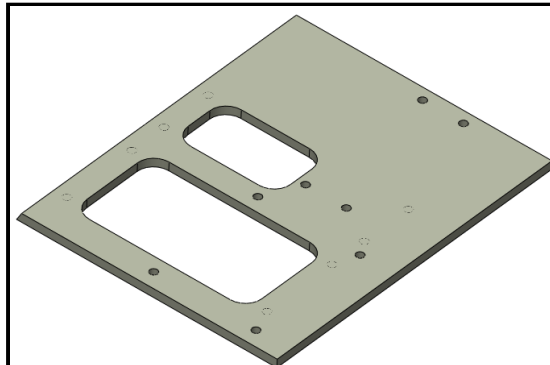

Tut5_Part3.SLDPRT

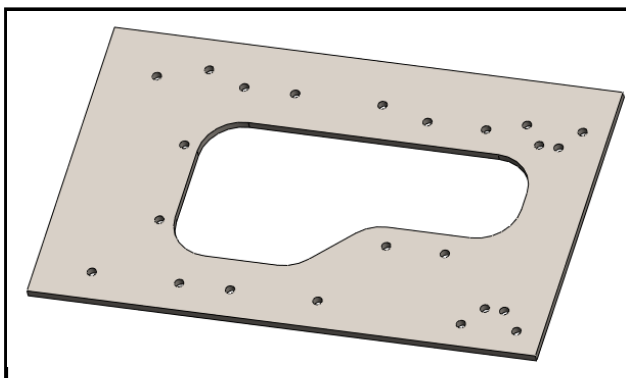

Tut5_Part5.SLDPRT

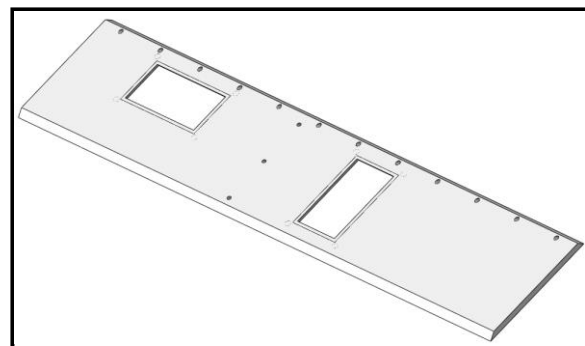

Tut5_Part6.SLDPRT

Only parts with identical material and thickness can be nested within the same sheet. Based on the above observation, it is clear that 2 different sheets need to be defined to generate nested layouts. Each such sheet will nest parts having the same material and thickness.

Step Angle & Quantity

Set the following quantities for the parts:

Part Name	Step Angle to be assigned	Quantity to be assigned
Tut5_Part1	90 ⁰	12
Tut5_Part2	90 ⁰	10
Tut5_Part3	90 ⁰	11
Tut5_Part4	90 ⁰	10
Tut5_Part5	90 ⁰	10
Tut5_Part6	90 ⁰	9



Normal Face

No changes are made to the default normal face selection for any of the parts.

Grain Direction

Leave the Grain direction set to *None* for all the parts.

Assembly	Part Name	Thickness	Quantity	Material	Rotation Type	Angle	Grain Director
<input checked="" type="checkbox"/>	TempNestAss...		1				
<input checked="" type="checkbox"/>	Tut5_Part1 [Def...	10mm	12	Alloy Steel ...	Step angle	90	None
<input checked="" type="checkbox"/>	Tut5_Part2 [Def...	12.7mm	10	Steel	Step angle	90	None
<input checked="" type="checkbox"/>	Tut5_Part3 [Def...	12.7mm	11	Steel	Step angle	90	None
<input checked="" type="checkbox"/>	Tut5_Part4 [Nes...	10mm	10	Alloy Steel ...	Step angle	90	None
<input checked="" type="checkbox"/>	Tut5_Part5 [Def...	12.7mm	10	Steel	Step angle	90	None
<input checked="" type="checkbox"/>	Tut5_Part6 [Def...	12.7mm	9	Steel	Step angle	90	None

Setting appropriate Part angle and Quantity for the parts

STEP 4: Defining Sheet Parameters

To nest all the six parts in the part list, three different sheets of varying thickness and material need to be added to the sheet list.



Adding Standard Sheet

Since the parts *Tut5_Part1.SLDPRT* and *Tut5_Part4.SLDPRT* have identical material *Alloy Steel (SS)* and thickness **10mm**, they can be nested within the same sheet.

To add a standard sheet to nest these parts, following are the steps:

1. Click on the *Sheet Data* tab.
2. In the Sheet list, click on *Select to add sheet*.
3. By default, the thickness of the first part listed in the Part list is 10 mm. In case this value is not displayed in the thickness field, assign a **10 mm** value.
4. By default, the material of the first part listed in the Part list is *Alloy Steel (SS)*. In case this value is not displayed in the material field, type the material name into the field.
5. To add a standard sheet, select the sheet type as standard and select *S11 (10' X 4') – Len: 3000 mm Width: 1200 mm* sheet from the dropdown List below sheet type.
6. In the Quantity field, assign a quantity of **1**.
7. Click *Add Sheet* to add the sheet to the Sheet list.

Adding Standard Sheet 2

Next, the parts *Tut5_Part2*, *Tut5_Part3*, *Tut5_Part5* and *Tut5_Part6* have identical material *Steel* and thickness **12.7mm**. They can be nested on the same sheet.

Follow the same steps mentioned above to add the standard sheet to nest these parts.

1. In step 5, choose the standard sheet of size *S22 (12' X 10') – Len: 3600 mm Width: 3000 mm* from the dropdown list below the sheet type.
2. In step 3, a thickness of 12.7 mm needs to be assigned to the sheet. Observe that NESTINGWorks already displays **12.7mm** as the default thickness.
3. In step 4, you need to assign the material of the sheet as *Steel*. Observe that NESTINGWorks already now displays this material in the material field.

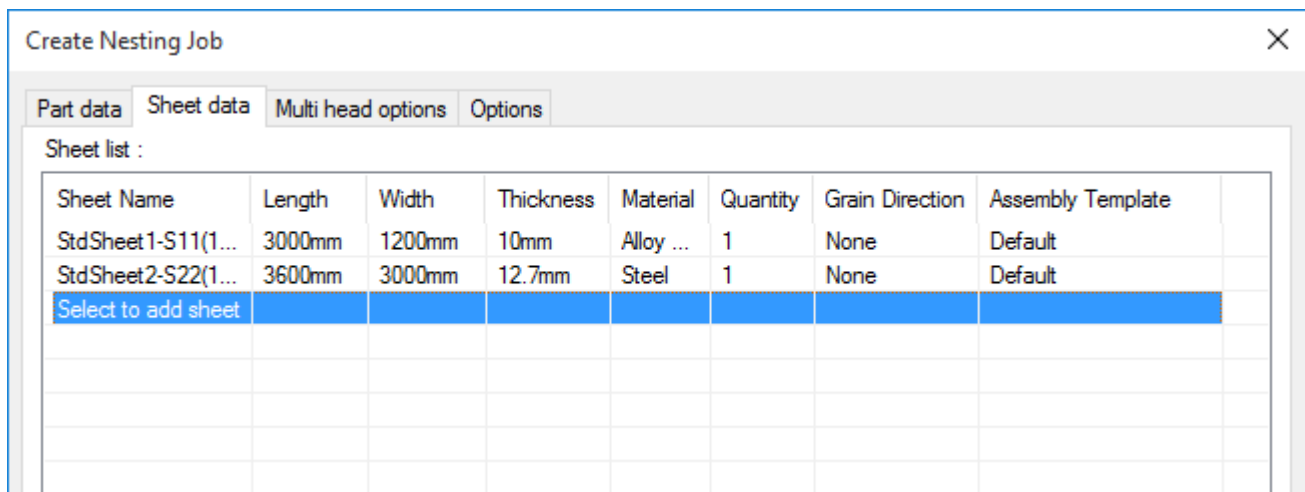

Adding multiple sheets of varying thickness and material to the sheet list



STEP 5: Selecting a machine with Single Tool Head for the Nesting Process

1. Click on the *Multi head options* tab.
2. In the *Machine Data* group box, ensure that the Machine selected is *SingleTHMachine*. The *Number of tool heads* for this machine should be '1'.

Selecting *SingleTHMachine* as the machine ensures the nesting job is executed considering a single tool head and not multiple tool heads.

STEP 6: Define Nesting Parameters

1. Click on the *Options* tab.
2. Set a *Part to Part distance* of **5mm** and a *Part to Sheet distance* of **5mm**.
3. Select *Fast Nesting* as the Nesting method.
4. Click *Preview Nest...* button to preview the nested layout.

The screenshot shows the 'Create Nesting Job' dialog box with the 'Options' tab selected. The 'Part to part distance' is set to 5mm and 'Part to sheet distance' is set to 5mm. The 'Ignore Part Thickness' checkbox is unchecked. The 'Align part face with sheet' dropdown is set to 'Top'. The 'Assembly Template' is set to 'C:\ProgramData\SolidWorks\SOLIDWORKS 2018\templates'. The 'Save output as dxf' checkbox is unchecked. The 'Generate Remnants' checkbox is unchecked. The 'Type of Remnant' is set to 'Rectangular'. The 'Remnant Output' is set to 'Sketches in Assembly'. The 'Create separate remnant assembly' checkbox is unchecked. The 'Area constraints' are set to 'Constraint By % of Sheet Area' with a value of 0.1%. The 'Width Constraints' are set to 'Constraint By % of Sheet Height' with a value of 0.1%. The 'Nesting type' is set to 'Fast nesting'. The 'Max. nesting time' is set to 0 min. The 'Create separate assembly' checkbox is unchecked. The 'Automatically select sheet' checkbox is checked. The 'Preview Nest...' button is highlighted.

Create Nesting Job Options Dialog Box



5. Click *Generate Nested Assembly* in the *Nesting Preview* window to execute the nesting process.
6. Leave the checkbox *Save output as dxf* unchecked.

STEP 7: Generating the Nested Layout

The nested layouts are generated in two file formats:

- Assembly file format (.sldasm)
- Drawing Exchange Format (.dxf)

Saving Files in the .dxf format

Browse to the folder location assigned for saving the nested layouts in .dxf format. Since two nested layouts were generated, observe that two separate files have been saved in the .dxf format in this folder.

Summary File

The Summary text file indicates that all the parts have been nested. Observe that the smaller parts have been nested in the holes of the larger parts.



```

NestAssm-TempNestAssm.SLDASM.ResultsSummary - Notepad
File Edit Format View Help
Nest Results Summary
=====
Total Number of Sheets Nested      : 2
Total Number of Part Instances Nested : 62
Overall Utilization                 : 76.889
=====

Nestded Part Quantity   Desired Quantity   Part Name
-----
9                       9                 Tut5_Part6 [Default]
10                      10                Tut5_Part5 [Default]
10                      10                Tut5_Part4 [Nest-FlatPattern_Default]
11                      11                Tut5_Part3 [Default]
10                      10                Tut5_Part2 [Default]
12                      12                Tut5_Part1 [Default]
-----

Total no. of Sheets   Parts per Sheet   Sheet Name
-----
1                     40                StdSheet2-S22(12'X10')
1                     22                StdSheet1-S11(10'X4')
-----

Layout Name      : Layout1[Steel_12.7mm_Qnty1]
No. of Sheets   : 1
Sheet Name      : StdSheet2-S22(12'X10')
Sheet Length(mm): 3600.00
Sheet Width(mm) : 3000.00
Sheet Thickness(mm) : 12
Material        : Steel
Sheet Utilization : 75.697

Nestded Qty per Sheet   Nestded Qty per layout   Total Nestded Qty   Part Name
-----
9                       9                       9                   Tut5_Part6 [Default]
10                      10                      10                  Tut5_Part5 [Default]
11                      11                      11                  Tut5_Part3 [Default]
10                      10                      10                  Tut5_Part2 [Default]
-----

Layout Name      : Layout2[Alloy Steel (SS)_10mm_Qnty1]
No. of Sheets   : 1
Sheet Name      : StdSheet1-S11(10'X4')
Sheet Length(mm): 3000.00
Sheet Width(mm) : 1200.00
Sheet Thickness(mm) : 10.00
Material        : Alloy Stee
Sheet Utilization : 80.464

```

Summary Text File



Viewing the Nested Layouts

Use the SOLIDWORKS Configurations tree to view the Nested layouts generated.

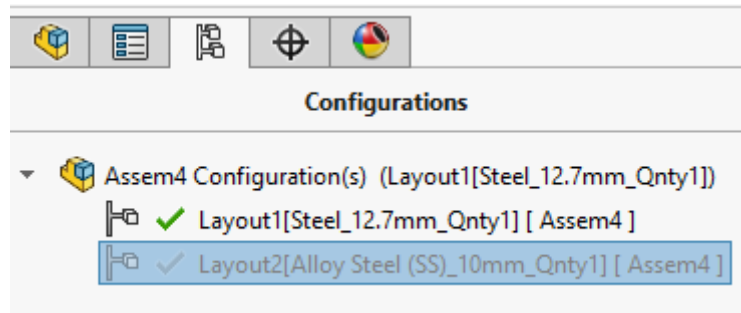

SOLIDWORKS Configuration Tree



Nesting layout (Tut5_Part2.SLDPRT, Tut5_Part3.SLDPRT, Tut5_Part5.SLDPRT and Tut5_Part6.SLDPRT)

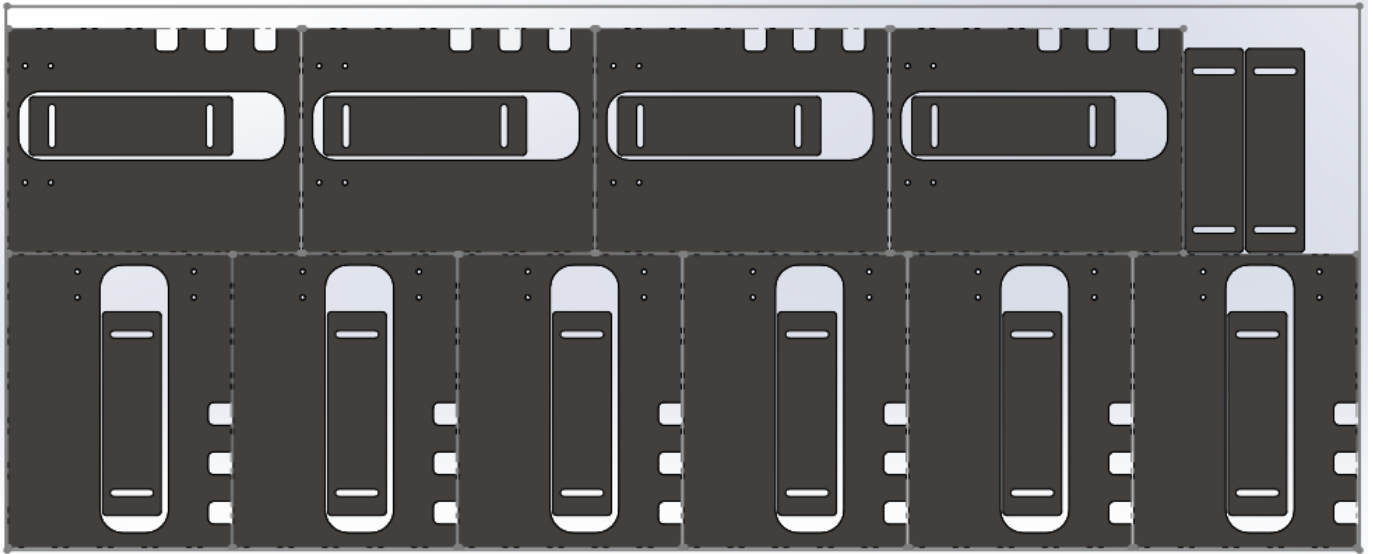

Nesting layout with preferential hole filling (Tut5_Part1.SLDPRT & Tut5_Part4.SLDPRT)



TUTORIAL 6 – NESTING WITH MULTIPLE TOOL HEADS

Introduction

This tutorial explains how to nest multiple solid parts of the same thickness and material in two or more identical layouts on a sheet simultaneously by using multiple tool heads.

Topic covered in this Tutorial:

- Activating the functionality of nesting with multiple tool heads.
- Nesting parts within a sheet using multiple tool heads to create identical nested regions.

STEP 1: Open the Assembly

Open the assembly file **Tutorial_6_Multi_Tool.SLDASM** in the following folder location.
C:\ProgramData\NESTINGWorksData\NESTINGWorks 201Xx64\Examples\Tutorials\Assemblies\Tutorial6

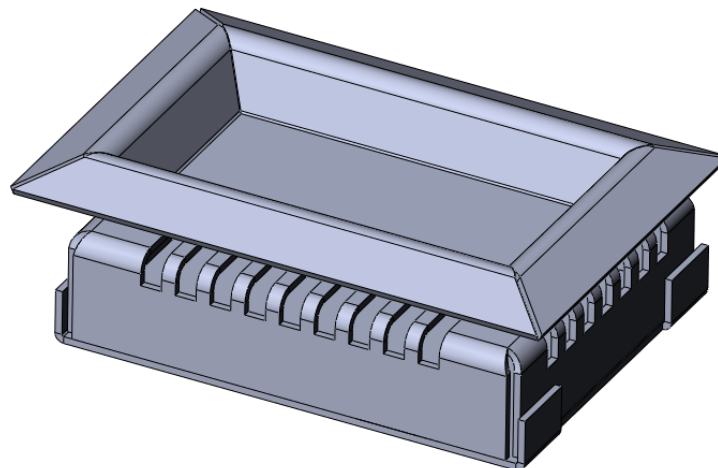

Tutorial_6_Multi_Tool.SLDASM

This assembly is made up of three parts.

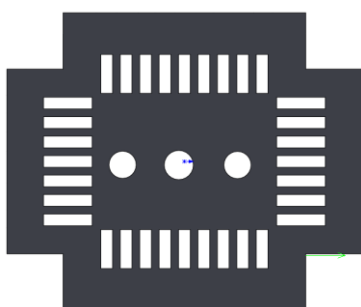

Tutorial_6_Part1.SLDPRT



Tutorial_6_Part2.SLDPRT

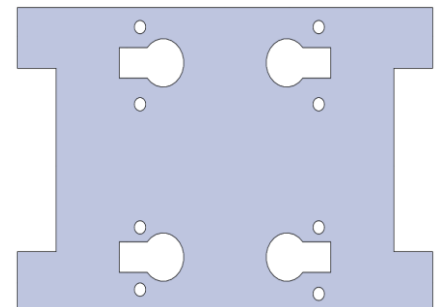

Tutorial_6_Part3.SLDPRT



STEP 2: Enabling the option of flattening the sheet metal parts

In this tutorial, you will nest the sheet metal part based on its dimensions after flattening. The default settings configured in the *DefaultValues.ini* file ensure that sheet metal parts are flattened before the nesting job is executed. If you are unsure about the settings, open the *DefaultValues.ini* file (explained in *NESTINGWorks Configuration Files and Associated Settings Guide*) and set the *FlattenSheetMetalPart* flag to '1' in order to activate the option of flattening.

STEP 3: Define the Part Parameters

1. Select *Create Nest Job* from the NESTINGWorks Ribbon bar.
2. The *Select Parts for Nesting* dialog box will be displayed. If the *Filter Type* is set to **All**, then the parts which constitute the assembly will be listed for selection in this dialog box. Within this dialog box:
 - a. Set the *Filter Type* to **All**. (This ensures that all components of the assembly are displayed.)
 - b. To select all the parts for nesting, place a tick in the checkbox next to **Parts**. (This action ensures that all listed components of the assembly are selected for nesting.)
 - c. Click the **OK** button in this dialog box.

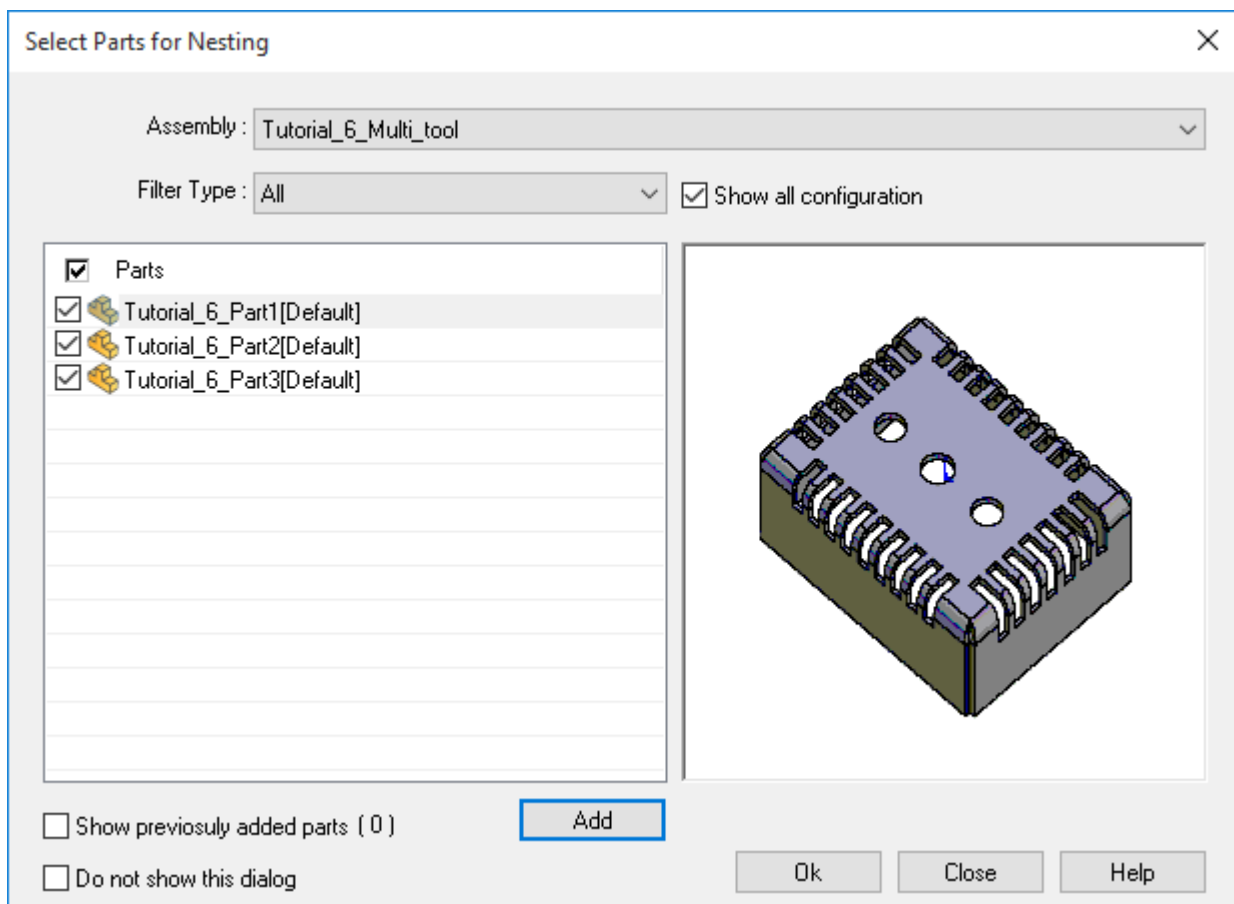

'Select Parts for Nesting' dialog Box



- The **Create Nesting Job** dialog box will be displayed. Observe that the parts selected for nesting in the previous dialog box are listed in this dialog box.

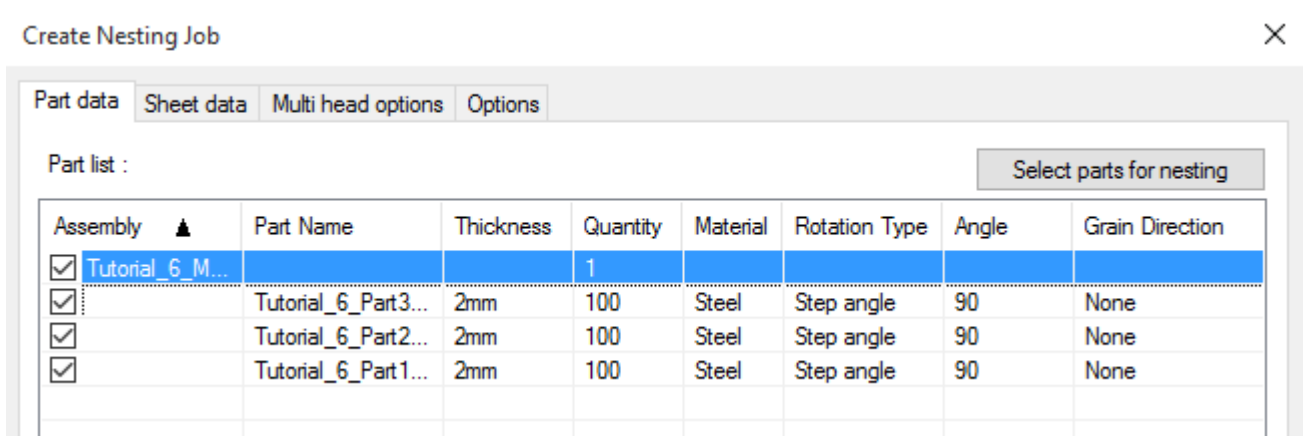

Defining the Part Parameters

- Observe the Thickness and the Material of all the three parts are identical. These default values will remain unchanged. Identical thickness and material will enable nesting of these parts in the same sheet.
- Assign the Quantity **100** to all the three parts.
- Assign a Step Angle of **90 degrees** to all the three parts.
- Assign the material as *Steel* for all the parts.
- Leave the Grain Direction set to *None* for all the three parts.

STEP 4: Define the Sheet Parameters

In this exercise, you will use a custom sheet with a length of 3000mm and width of 2900mm to nest the parts.

- Click on the *Sheet Data* tab of the Create Nesting Job dialog box.
- In the Sheet list, click on *Select to add sheet*.
- By default, the thickness of the first part given in the Part list is given as the Thickness field **2mm**. Leave this parameter value as it is.
- By default, the material of the first part listed in the Part list is given in the Material field *Steel*. Leave this parameter value as it is.
- In the Quantity field, assign a quantity of **1**.
- Leave the Grain Direction set to *None* and the Assembly Template set to *Default*.
- To add a custom size sheet, select the *Custom sheet* option in the Sheet type dropdown list.
- Assign a Length of **3000mm** and a Width of **2900mm**.
- Click *Add Sheet* to add the sheet to the Sheet list.



Create Nesting Job X

Part data Sheet data Multi head options Options

Sheet list :

Sheet Name	Length	Width	Thickness	Material	Quantity	Grain Direction	Assembly Template
CustomSheet1(30...	3000...	290...	2mm	Steel	1	None	Default
Select to add sheet							

Thickness : 2mm

Quantity : 1 Sheet Forecaster

Material : Steel

Grain direction : None

Assembly template : Default

Sheet type : Custom Sheet

Length : 3000mm

Width : 2900mm

Sheet preview :

Add sheet Remove sheet

Restore Defaults Preview Nest... Cancel Help

Sheet data Tab of 'Create Nesting Job' dialog box

STEP 5: Define the Multi head options parameters

To nest using multiple tool heads, it is necessary to assign appropriate values to the parameters associated with nesting using multiple tool heads. The *Multi head options* tab of the *Create nesting Job* dialog box allows you assign/edit these parameters.

1. Click on the *Multi head options* tab of the Create Nesting Job dialog box.
2. The Sheet list in this dialog box lists the Custom sheet added in the Sheet Data tab. The parameters associated with nesting using multiple tool heads have to be defined separately for each sheet listed in the Sheet list.
3. Highlight the one sheet listed in the Sheet list.



NESTINGWorks Tutorial

- In the Machine dropdown list, select *MachineName1* for the machine.
- In case your Machine list has already been customized to suit your facility's requirements, then *MachineName1* will not be listed.

To proceed with the tutorial, you can do one of the following:

- Create a dummy machine named *MachineName1* with associated parameters in the Machine.ini file so that the machine is listed here in this list. This is explained in the section *Adding a new machine to the Machine.ini file* explained in *NESTINGWorks Configuration Files and Associated Settings Guide*.
 - Select another machine from the *Machine* list which has at least 5 tool heads. All the other parameters can be edited to suit the requirements of this tutorial before the nesting job is executed.
- The default values for the parameters associated with *MachineName1* will be displayed. (These default values are defined in the Machine.ini file.)

The default values associated with the parameters are:

Number of Tool heads	5
Rail Direction	X
Multi-tool head nesting type	Fixed tool head distance
Tool head distance	500mm
Tut5_Part5	90°
Tut5_Part6	90°

In case you selected a machine other than *MachineName1*, edit the parameters to assign them the values/options given above.

- In this tutorial, the nesting with multiple tools will be executed using the default parameter values associated with the machine *MachineName1*.

The screenshot displays the software's configuration window. On the left, under 'Machine data', the 'Machine' dropdown is set to 'MachineName1' and 'Number of tool heads' is set to '5'. Below this, 'Rail direction' has radio buttons for 'X' (selected) and 'Y'. 'Multi-tool head nesting type' has radio buttons for 'Fixed tool head distance' (selected) and 'Variable tool head distance'. 'Tool head distance' is set to '500mm'. On the right, 'Sheet preview' shows a large empty rectangular area. At the bottom, there are buttons for 'Restore Defaults', 'Preview Nest...', 'Cancel', and 'Help'.



Defining the Multi head options parameters for nesting with multiple tool heads

STEP 6: Define Nesting Parameters

1. Click on the *Options* tab.
2. Set a *Part to Part distance* of **10mm** and a *Part to Sheet distance* of **10mm**.
3. *Fast Nesting* is the default *Nesting type*.
4. Leave the *Create separate assembly* checkbox unchecked.
5. Click *Preview Nest...* button to preview the nested layout.
6. Click *Generate Nested Assembly* in the Nesting Preview window to execute the nesting process.

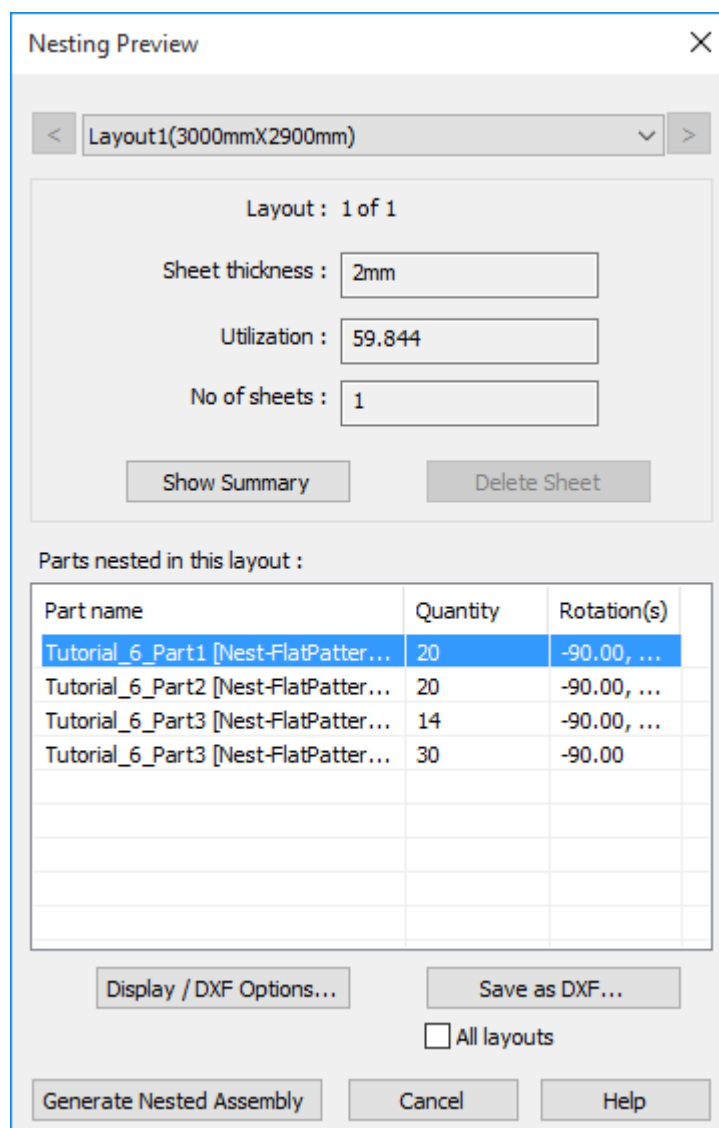

Nesting Preview dialog box



STEP 7: Generating the Nested Layout

The Summary text file indicates that the prescribed quantities for all the parts have been nested within the sheet.

```

NestAssm-Tutorial_6_Multi_tool.SLDASM.ResultsSummary - Notepad
File Edit Format View Help
Nest Results Summary
=====
Total Number of Sheets Nested      : 1
Total Number of Part Instances Nested : 300
Overall Utilization                 : 59.844
=====

Nested Part Quantity   Desired Quantity   Part Name
-----
100                    100                Tutorial_6_Part3 [Nest-FlatPattern_Default]
100                    100                Tutorial_6_Part2 [Nest-FlatPattern_Default]
100                    100                Tutorial_6_Part1 [Nest-FlatPattern_Default]
-----

Total no. of Sheets   Parts per Sheet   Sheet Name
-----
1                     300               CustomSheet1(3000mmX2900mm)
-----

Layout Name      : Layout1[Steel_2mm_Qnty1]
No. of Sheets    : 1
Sheet Name       : CustomSheet1(3000mmX2900mm)
Sheet Length(mm): 3000.00
Sheet Width(mm) : 2900.00
Sheet Thickness(mm) : 2.
Material         : Steel
Sheet Utilization : 59.844

Nested Qty per Sheet   Nested Qty per layout   Total Nested Qty   Part Name
-----
35                     35                      100                Tutorial_6_Part3 [Ne
65                     65                      100                Tutorial_6_Part3 [Ne
100                    100                     100                Tutorial_6_Part2 [Ne
100                    100                     100                Tutorial_6_Part1 [Ne
    
```

Nesting Results Summary Text file

Observe the nested layout. The five tool heads used create 5 identical nested layouts in the 'X' direction.

20 instances of the first part (*Tutorial_6_Part1.SLDPRT*), 20 instances of the second part (*Tutorial_6_Part2.SLDPRT*) and 5 instances of the third part (*Tutorial_6_Part3.SLDPRT*) are nested in each identical nesting region.

Thus, 100 instances of the first two parts are nested within the 5 identical regions. Only 25 instances of the third part are nested within the identical regions. The remaining 75 instances can be nested in the remnant sheet left after nesting the 5 regions.



Parts which remain
to be machined



Nesting layout with 5 identical regions created using 5 tool heads



TUTORIAL 7 – NESTING IMPORTED SHEET METAL COMPONENTS WITH BENDS

Introduction

This tutorial explains how to unfold imported 3D sheet metal components with bends using various menu options available within NESTINGWorks.

Topic covered in this Tutorial:

- [Using the 'Unfold Imported Bodies' dialog box](#)
- [Using the 'Enable Auto Unfold' option](#)
- [Using the 'Intelligent Unfold' command](#)
- [Using the 'Unfold All Parts' command](#)

The functionality of Unfolding Sheet Metal Parts

NESTINGWorks supports nesting of imported part models. If the sheet metal parts to be nested contain bends, then these parts should ideally be unfolded before the nesting job is executed.

Most native sheet metal parts (parts created using the solid modeler of SOLIDWORKS) as well as imported sheet metal parts can be unfolded using the in-built functionality of the Solid Modeler itself. However, sheet metal parts with complex architectures can sometimes be flattened/unfolded incorrectly.

NESTINGWorks provides a more robust functionality for unfolding both imported and native sheet metal parts. Sheet metal parts that are unfolded incorrectly by the Solid Modeler can be unfolded correctly using this functionality.

The 'Unfold Imported Bodies' dialog box

The NESTINGWorks functionality for unfolding both native and imported sheet metal parts is provided in the form of 'Unfold Imported Bodies' dialog box. This dialog box allows you to select sheet metal parts with bends to be unfolded and assign parameters associated with unfolding sheet metal parts.

Note: The functionality of Unfolding is meant for sheet metal parts only. If the part(s)/ assembly to be nested contain imported solid parts, then these imported solid parts too will be displayed in the 'Unfold Imported Bodies' dialog box. Ensure that you unselect the solid parts from the list of parts to be unfolded.



Commands to Invoke 'Unfold Imported Bodies' dialog box

1. The 'Enable Auto Unfold' Option

Click on the *Tools* menu and select *NESTINGWorks* menu from the dropdown list, then observe that the *Enable Auto Unfold* option is checked by default.

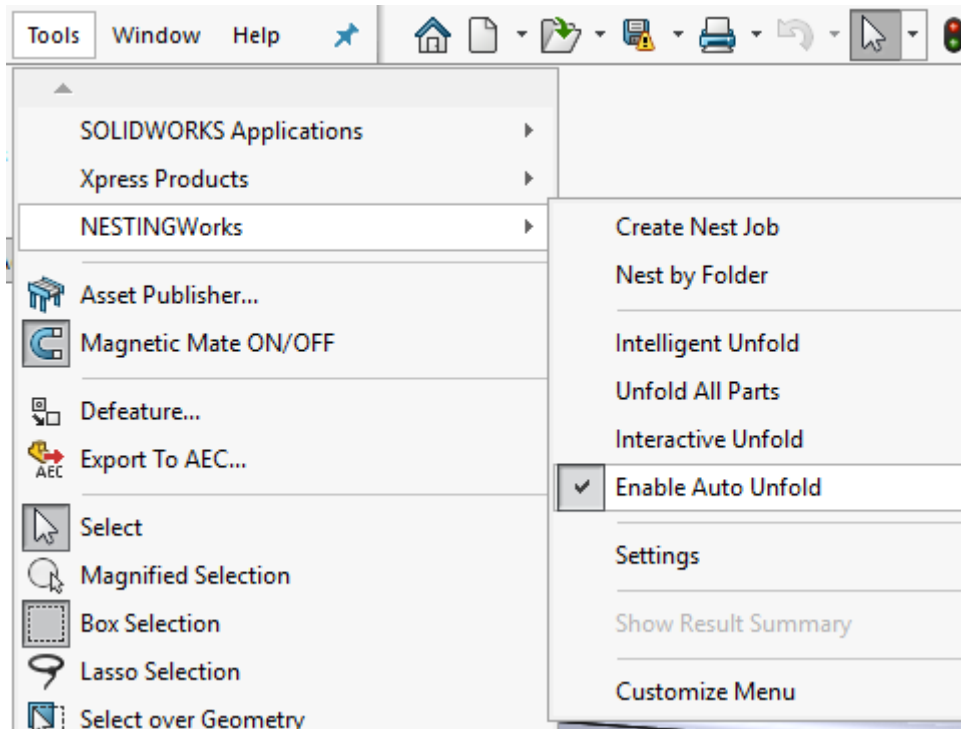

'Enable Auto Unfold' option in NESTINGWorks cascading menu

- When the *Enable Auto Unfold* option is checked and the *Create Nest Job* command is executed for part(s) containing one or more imported bodies, NESTINGWorks will automatically display the *Unfold Imported Bodies* dialog box. Use this dialog box to select the bodies to be unfolded and set the parameters associated with unfolding.
- When the *Enable Auto Unfold* option is checked and the *Create Nest Job* command is executed for an assembly containing one or more imported bodies, the *Select Parts for Nesting* dialog box will be displayed. If the imported bodies present in the assembly are selected for nesting and the OK button is clicked, then NESTINGWorks will automatically display the *Unfold Imported Bodies* dialog box. Use this dialog box to select the bodies to be unfolded and set the parameters associated with unfolding.
- When the *Enable Auto Unfold* option is not checked and the *Create Nest Job* command is executed for part(s) containing imported bodies, then the *Create Nesting Job* dialog box will be displayed with native parts unfolded and imported parts in an unfolded state.
 - ➔ These native parts will either be unfolded/remain folded based on settings for Flattening sheet metal parts in the **DefaultValues.ini** explained in *NESTINGWorks Configuration Files and Associated Settings Guide*.
- When the *Enable Auto Unfold* option is not checked and the *Create Nest Job* command is executed for an assembly containing one or more imported bodies, the *Select Parts for Nesting* dialog box will be displayed. If the imported bodies present in the assembly are selected for nesting and the OK button is clicked, then the



Create Nesting Job dialog box will be displayed with native parts unfolded and imported parts in an unfolded state.

2. The 'Intelligent Unfold' Command

Function

The Solid Modeler (SOLIDWORKS) can only unfold native sheet metal parts with bends. Imported sheet metal parts with bends cannot be unfolded using SOLIDWORKS functionality. The '*Intelligent Unfold*' command is ideal for nesting parts/assemblies comprising imported sheet metal part(s) with bends.

Command Execution

1. Selecting the *Intelligent Unfold* command from NESTINGWorks cascading menu in the graphics area opens the *Unfold Imported Bodies* dialog box.

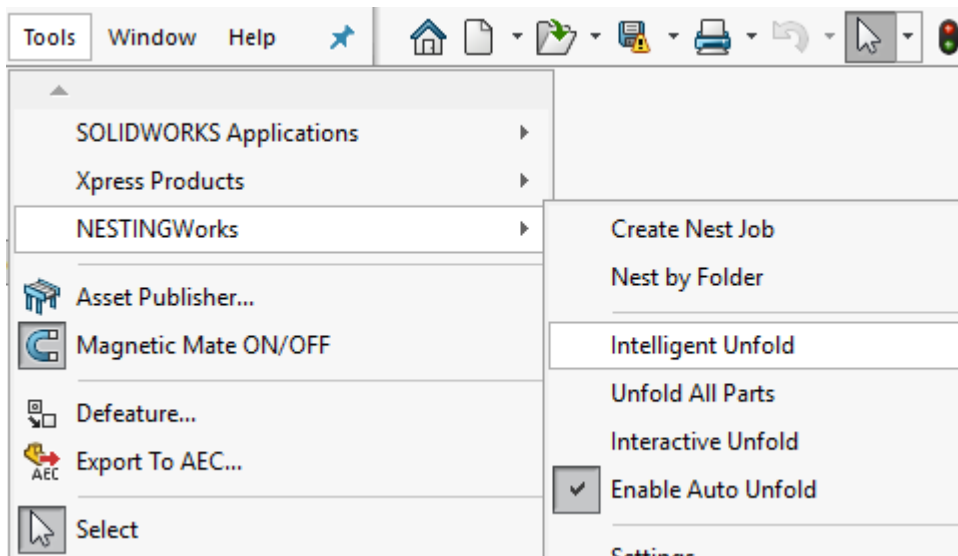

'Intelligent Unfold' command on NESTINGWorks cascading menu

2. Alternatively, clicking on the *Intelligent Unfold* button on the NESTINGWorks Ribbon Bar to open this dialog box.

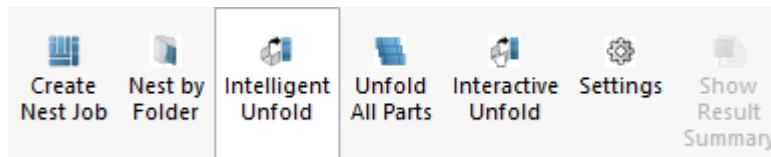

'Intelligent Unfold' button in the NESTINGWorks Ribbon Bar

How it works

When the *Unfold Imported Bodies* dialog box is opened using the *Intelligent Unfold* command, only imported parts will be listed. Any native part present will not be listed. If there are any imported solid bodies listed in the grid, ensure that you unselect them to avoid unfolding. Use this dialog box to set parameters associated with flattening the parts before nesting.



Note: If you open the 'Unfold Imported Bodies' dialog box using either the 'Intelligent Unfold' or 'Create Nest Job' command, then only imported sheet metal parts with bends will be listed in the dialog box. Native sheet metal parts with bends, if present, will not be listed.

When you click *OK* button of this dialog box:

1. The imported sheet metal parts selected for unfolding will be unfolded based on user-defined parameters input in this dialog box.
2. Native sheet metal bodies with bends, if present in the parts/assembly, will either unfolded/remain folded based on settings for Flattening sheet metal parts in the *DefaultValues.ini*. The Solid Modeler's functionality for unfolding will be applied for unfolding the native sheet metal parts.

Next Step

After unfolding the imported parts using this dialog box, you can click on the *Create Nest Job* command to proceed with the nesting process.

3. The 'Unfold All Parts' Command

Function

The Solid Modeler (SOLIDWORKS) has in-built functionality for unfolding native sheet metal parts with bends. *NESTINGWorks* too contains an in-built functionality to unfold both native and imported sheet metal parts.

However, certain native sheet metal parts can sometimes be incorrectly unfolded by the Solid Modeler. Such parts can then be alternatively unfolded using the *NESTINGWorks* functionality.

The 'Unfold All Parts' command is ideal when you wish to unfold all sheet metal parts with bends (both native and imported) using the *NESTINGWorks* functionality of unfolding.

When this command is executed:

1. The imported sheet metal parts will be unfolded using the *NESTINGWorks* functionality of unfolding.
2. For native sheet metal parts, you can select/unselect the native sheet metal parts to be unfolded using this functionality. Any unselected native part will then be unfolded using the Solid Modeler functionality of unfolding.

Command Execution

1. Clicking on the 'Unfold All Parts' command from the *NESTINGWorks* cascading menu to open the *Unfold Imported Bodies* dialog box.

Alternatively, clicking on the *Unfold All Parts* command on the *NESTINGWorks* Ribbon bar to open this dialog box.

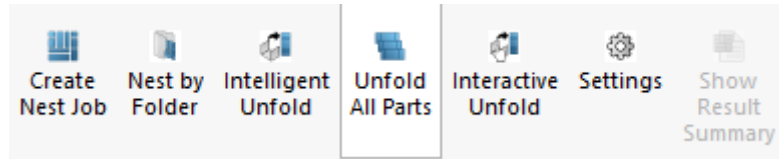

'Unfold All Parts' button on the NESTINGWorks Ribbon Bar

How it works

When the *Unfold Imported Bodies* dialog box is opened using the *Unfold All Parts* command, both imported parts as well as native parts will be listed within the dialog box.

- If there are any imported solid bodies listed in the grid, ensure that you unselect them to avoid unfolding.
- If there are any native sheet metal parts that you do not wish to unfold using the NESTINGWorks functionality for unfolding, ensure that you unselect such parts. Use this dialog box to set parameters associated with unfolding the sheet parts before nesting.

Note: If you open the 'Unfold Imported Bodies' dialog box using the 'Unfold All Parts' command, then both imported sheet metal parts with bends as well as native sheet metal parts with bends will be listed in the dialog box.

When you click *OK* button of this dialog box:

1. All the imported sheet metal parts selected for unfolding will be unfolded based on user-defined parameters input in this dialog box.
2. All native sheet metal parts listed in the dialog box which were selected for unfolding will be unfolded using the NESTINGWorks functionality for unfolding.
3. If any native sheet metal part listed in the dialog box was deselected from unfolding, then that part will be either be unfolded/remain folded based on settings for **Flattening sheet metal parts in the DefaultValues.ini** explained in *NESTINGWorks Configuration Files and Associated Settings Guide*. If unfolded, then the Solid Modeler's functionality for unfolding will be applied for unfolding the native sheet metal parts.

Next Step

After unfolding the sheet metal parts using this dialog box, you can execute the *Create Nest Job* command to proceed with the nesting process.

STEP 1: Open the Assembly

Open the assembly file **Tutorial7_Unfold_Assembly.SLDASM** in the following folder location.

C:\ProgramData\NESTINGWorksData\NESTINGWorks 201Xx64\Examples\Tutorials\Assemblies\Tutorial7

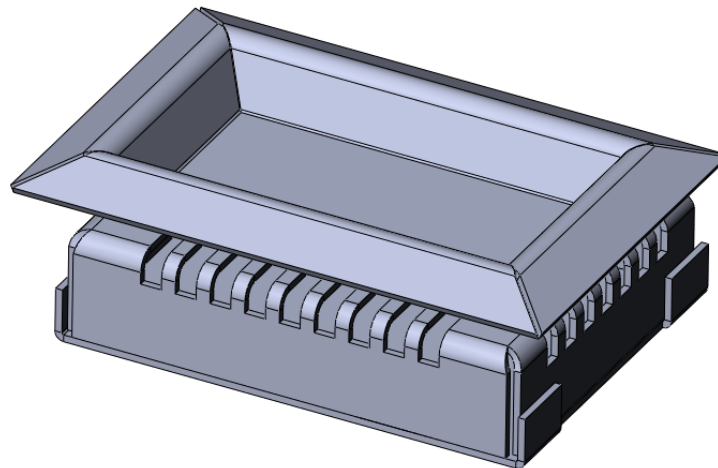
**Tutorial7_Unfold_Assembly.SLDASM**

This assembly comprises of three sheet metal parts:

- i. Tutorial_7a_Native.SLDPRT (native part)
- ii. Tutorial_7b_Imported.SLDPRT (imported part)
- iii. Tutorial_7c_Imported.SLDPRT (imported part)

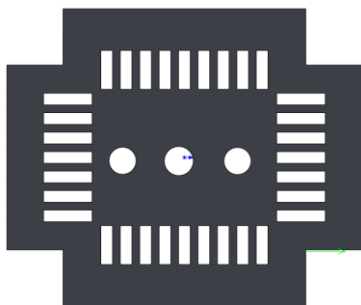
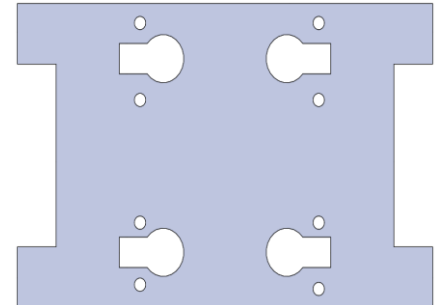
**Tutorial_7a_Native.SLDPRT****Tutorial_7b_Imported.SLDPRT****Tutorial_7c_Imported.SLDPRT**

STEP 2: Unfolding the Parts with bends

1. In the NESTINGWorks cascading menu, ensure that there is a check placed against the *Enable Auto Unfold* option. This ensures that this option is enabled.
2. Click on the *Create Nest Job* command in the NESTINGWorks Ribbon bar.
The *Select Parts for Nesting* dialog box will be displayed.
3. Since the **Filter Type** is set to **All**, the three component parts of the Assembly will be displayed in this dialog box.
4. The *Select Parts for Nesting* dialog box allows you to filter the components of an assembly based on their nature viz. native parts versus imported parts and sheet metal parts versus solid parts.
In the *Filter Type* dropdown list, select **Imported SheetMetal**.



- Observe that the dialog box now lists only those components of the assembly which are imported sheet metal parts. Place a tick in the checkbox next to **Parts** in order to select these listed imported sheet metal parts for nesting.

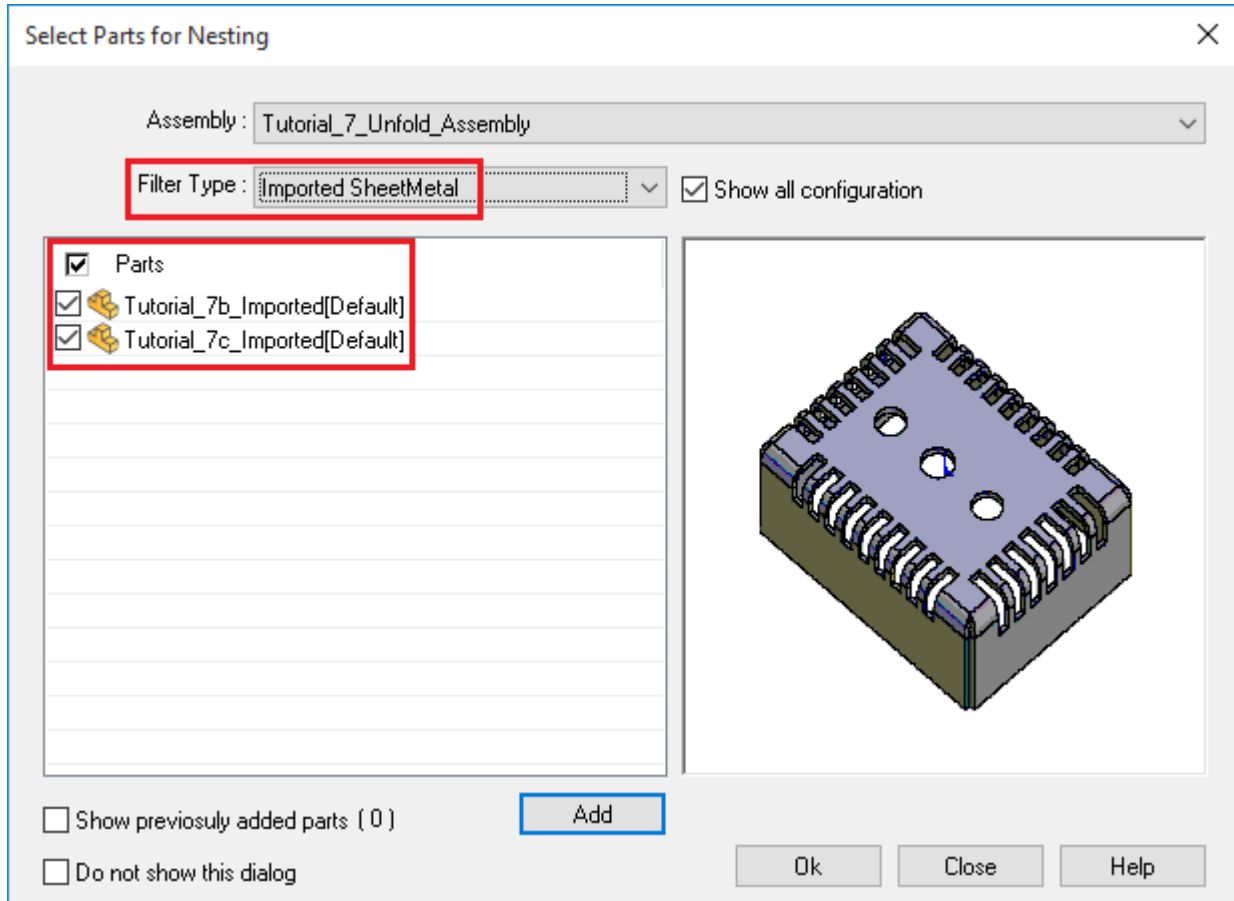

Only Imported Sheet Metal parts listed when Filter Type is set to 'Imported SheetMetal'

- Click on the **OK** button of this dialog box to close the dialog box and transfer information on the parts selected for nesting to the next UI for further processing.
- Since the components of assembly selected for nesting are imported sheet metal parts with bends, NESTINGWorks will display the **Unfold Imported Bodies** dialog box.

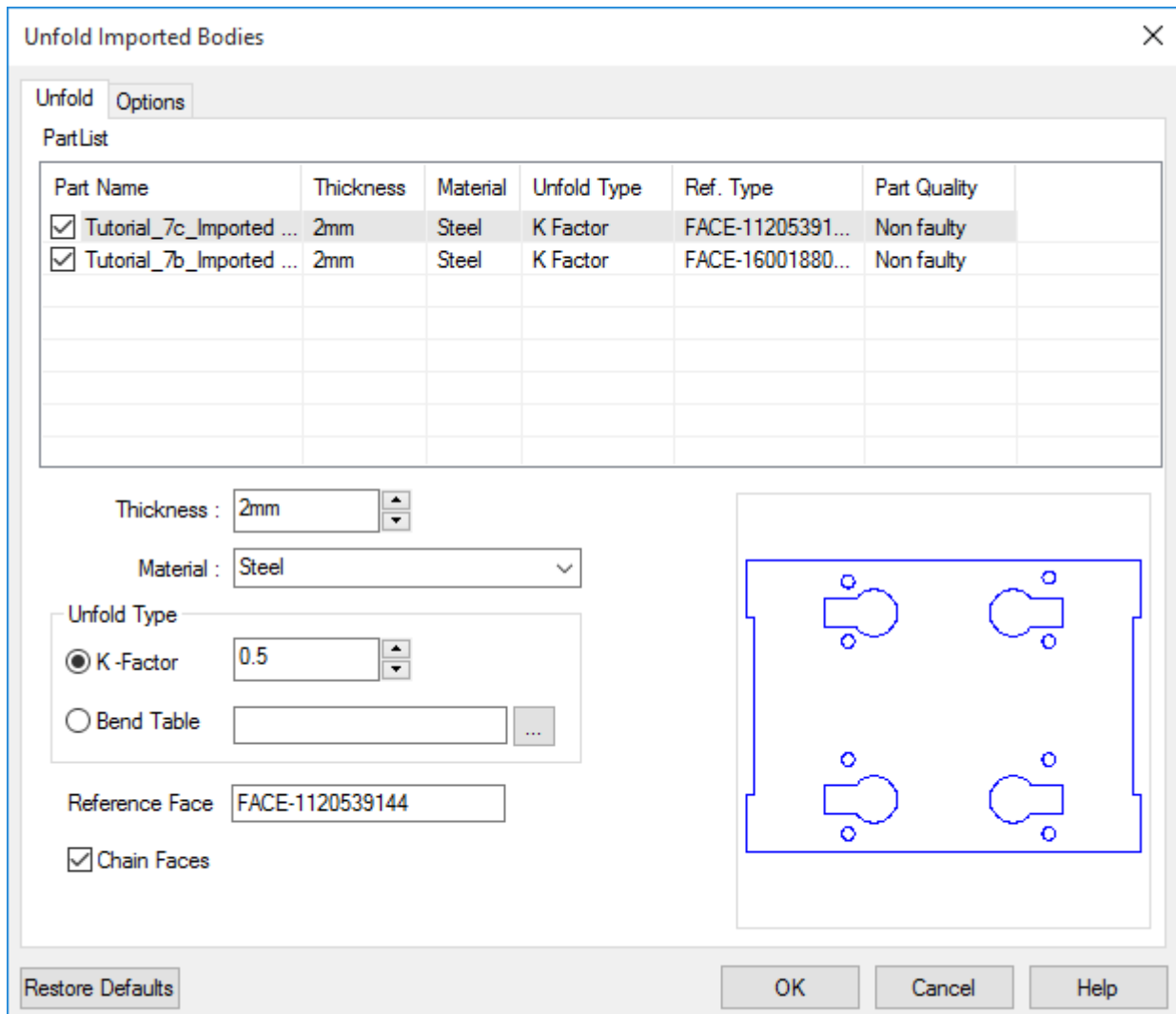

The 'Unfold Imported Bodies' dialog box

8. This dialog box is used to facilitate the unfolding of sheet metal parts and associated parameters before proceeding with a nesting job. All the imported parts comprising this assembly are listed Unfold tab of this dialog box. In this case, the sheet metal parts *Tutorial_7b_Imported.SLDPRT* and *Tutorial_7c_Imported.SLDPRT* will be listed.

9. In the Part List grid, remove the check from the checkboxes of those imported parts that you do not wish to unfold.

In this tutorial, you will unfold both the imported parts. Hence, do not remove the check from the check boxes.

10. Assign the following values to the Unfold Parameters:

- i. **Thickness & Material:** NESTINGWorks extracts the part parameter of Thickness and Material from the Solid Part and displays it in the Thickness and Material fields respectively as default thickness and material for the part. The thickness of the part, as extracted from the solid part, is displayed as **2mm** and the material is 'steel'. Leave these values as they are.

ii. **Unfold Type:**

- a. **K-factor:** NESTINGWorks displays K-factor value **0.5** as default for unfold of the part, you can change the K-factor.



b. **Bend Table:** Optionally you can also select the bend table.

In this tutorial, we will use the default value of the K-factor for both the sheet metal parts.

iii. **Reference face:** By default, NESTINGWorks chooses the face with the largest area as the Reference Face. In this tutorial, the bottom face of the solid part is chosen by default. The normal direction is indicated by an arrow in the graphics area.

11. Click the *OK* button of this dialog box to unfold the imported parts. The unfolded parts are displayed in the graphics area of SOLIDWORKS.

12. The *Create Nesting Job* dialog box is now displayed.

STEP 3: Defining the Part, Sheet & Nesting Parameters

Part Data Tab

In the *Part data* tab of the *Create Nesting Job* dialog box, assign the following values to the parameters:

1. **Thickness & Material:** Observe that the Thickness and the Material of all the three parts are identical. These default values will remain unchanged. Identical thickness and material will enable nesting of these parts in the same sheet.
2. **Quantity:** Assign the Quantity of **40** to both the parts.
3. **Step Angle:** Assign a Step Angle of **90 degrees** to both the parts.
4. **Grain Direction:** Leave the Grain direction set to *None* for both the three parts.

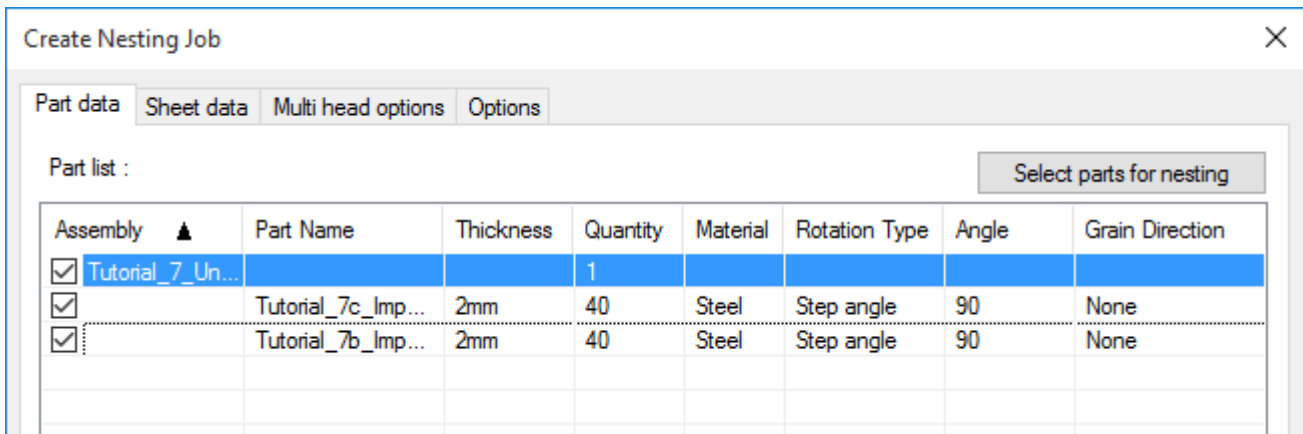

Defining the Individual Part Parameters in the 'Create Nesting Job' dialog box

Sheet Data Tab

In this tutorial, we will use a standard sheet of size *S3* [Length = 1800mm; Width = 1800mm] to nest all the three parts.

1. Click on the *Sheet data* tab of the *Create Nesting Job* dialog box.
2. In the Sheet list grid, click on *Select to add sheet*.
3. **Thickness & Material:** By default, the thickness and material of the first part given in the Part list grid of the Part Data tab is assigned as the thickness and material in the



Thickness **2mm** and Material *Steel* fields respectively. Leave these parameter values as it is.

4. **Quantity:** In the Quantity field, assign a quantity of **1**.
5. **Grain Direction:** Leave the Grain direction set to *None*.
6. **Assembly Template:** Leave the Assembly Template set to Default.
7. **Adding a Standard Sheet:** To add a Standard sheet type,
 - Select the Standard option in the sheet type dropdown list.
 - Below the sheet type dropdown list, select S3 (6" X 6") from the dropdown list.
8. Click on the *Add sheet* button to add the sheet to the Sheet List.

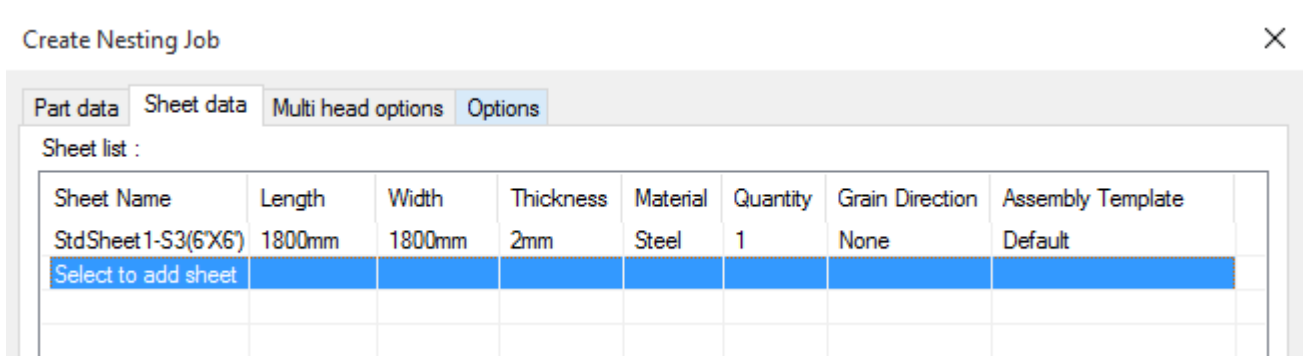

Sheet Data Tab of 'Create Nesting Job' dialog box

Assigning Nesting Parameters in 'Options' tab

Click on the *Options* tab and assign the following parameters:

1. Set a Part to Part distance of **10mm** and a Part to Sheet distance of **10mm**.
2. *Fast Nesting* is the default Nesting type.
3. Leave the *Create separate assembly* checkbox unchecked.
4. Click *Preview Nest...* button to preview the nested layout.
5. In the Nesting Preview window, click *Generate Nested Assembly* to execute the nesting process.

STEP 4: Generating the Nested Layout

Observer the Summary text file indicates that the prescribed quantities for all the parts have been nested within the sheet.

The nested layout assembly generated after executing the nesting job and the Summary Results file are stored in the same location as the parts to be nested.

All 40 instances of the each sheet metal part are nested within the same sheet.

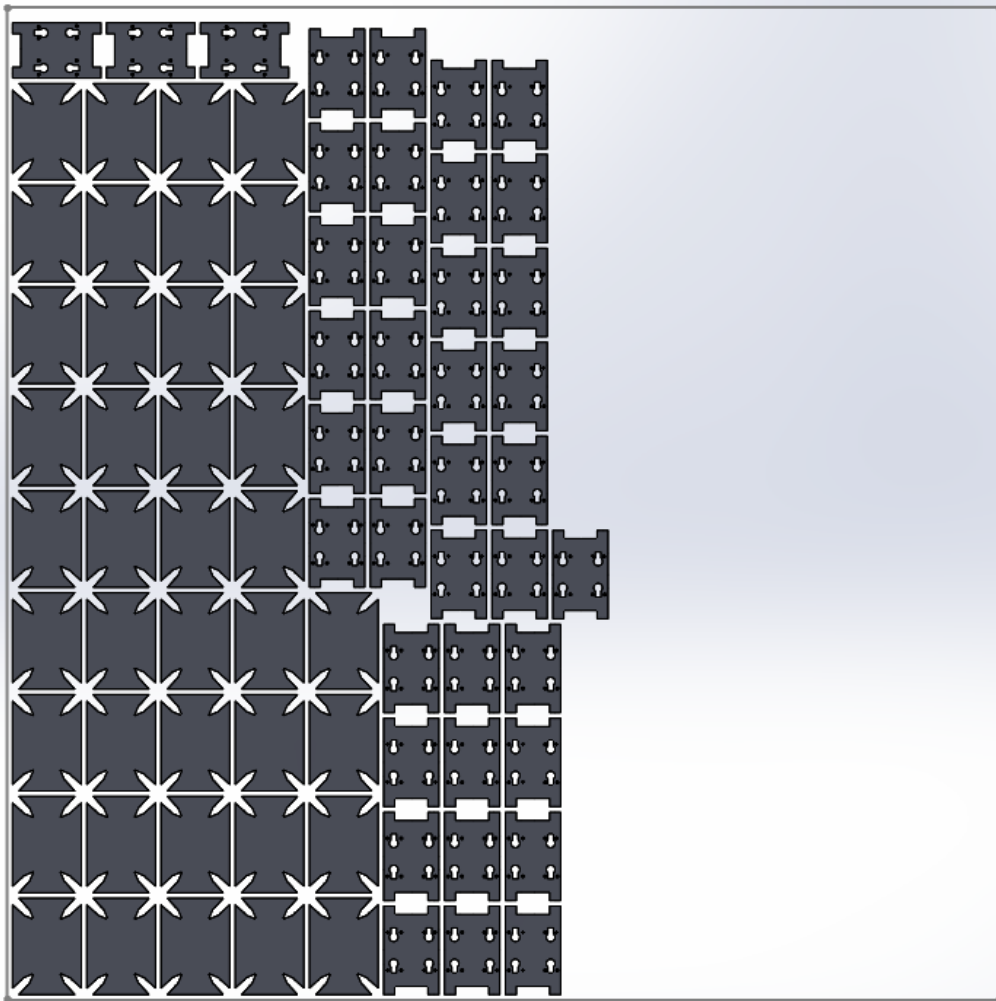

Nesting layout generated for all the imported parts comprising the assembly



NestAssm-Tutorial_7_Unfold_Assembly.SLDASM.ResultsSummary - Notepad

File Edit Format View Help

Nest Results Summary

=====

Total Number of Sheets Nested : 1
Total Number of Part Instances Nested : 2
Overall Utilization : 0.995

=====

Nested Part Quantity	Desired Quantity	Part Name
1	1	Tutorial_7c_Imported [Nest-FlatPattern_Default]
1	1	Tutorial_7b_Imported [Nest-FlatPattern_Default]

=====

Total no. of Sheets	Parts per Sheet	Sheet Name
1	2	StdSheet1-S3(6'X6')

=====

Layout Name : Layout1[Steel_2mm_Qnty1]
No. of Sheets : 1
Sheet Name : StdSheet1-S3(6'X6')
Sheet Length(mm): 1800.00
Sheet Width(mm) : 1800.00

Sheet Thickness(mm) : 2.00
Material : Steel
Sheet Utilization : 0.995

=====

Nested Qty per Sheet	Nested Qty per layout	Total Nested Qty	Part Name
1	1	1	Tutorial_7c_Imported [Nest-Fla
1	1	1	Tutorial_7b_Imported [Nest-Fla

=====

Nesting Result Summary Text file



TUTORIAL 8 – UNFOLDING IMPORTED 3D SHEET METAL COMPONENTS WITH FAULTY SURFACES

Introduction

The previous tutorial (Tutorial 7) explained how to unfold imported 3D sheet metal components using the 'Unfold Imported Bodies' dialog box before nesting such parts. However, NESTINGWorks cannot fully unfold imported sheet metal parts if such parts have faulty bodies or surfaces. Tutorial 8 explores how to nest imported sheet metal parts containing faulty bodies or surfaces.

It is recommended that you go through the concepts explained in Tutorial 7 before commencing with this tutorial.

Topic covered in this Tutorial:

- Selective Unfolding of faulty parts
- Using the 'Unfold Imported Bodies' dialog box to unfold imported sheet metal parts with faults

STEP 1: Open the Assembly

Open the assembly file **Tutorial8_Unfold_Assembly.SLDASM** in the following folder location:

C:\ProgramData\NESTINGWorksData\NESTINGWorks 201Xx64\Examples\Tutorials\Assemblies\Tutorial8

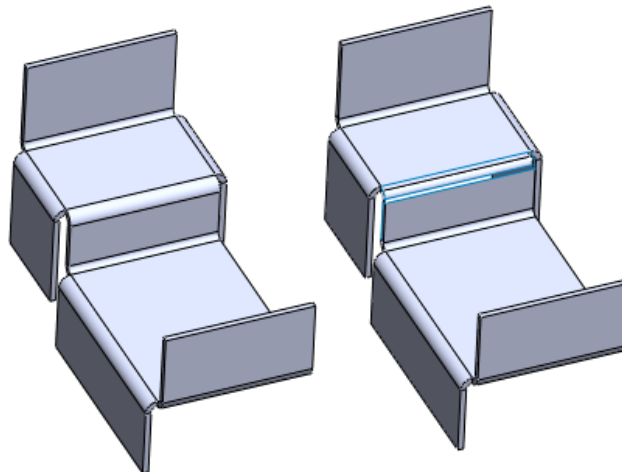

Tutorial8_Unfold_Assembly.SLDASM

This assembly comprises of two identical sheet metal parts:

- Tutorial_8a_Faulty.SLDPRT *(imported part)*
- Tutorial_8b_Non-Faulty.SLDPRT *(imported part)*

Though these two parts are identical, one of the parts has a faulty body.



STEP 2: Executing the 'Intelligent Unfold' command

1. In the NESTINGWorks Ribbon Bar, click on the menu item *Intelligent Unfold*.
2. Since one of the parts comprising this assembly has a faulty body, NESTINGWorks will display a message stating that the assembly contains faulty parts/surfaces and that you will need to select/deselect faces directly on the model for unfolding.

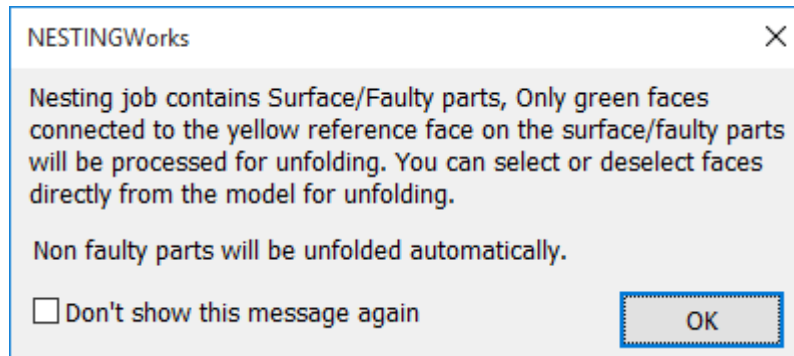

NESTINGWorks message indicating the presence of faulty imported parts with bends

3. Click *OK* to close this dialog box and proceed with nesting.

If you don't wish to see this error message again in future nesting jobs, select *Don't show this message again* before you click *OK*.

If you click *CANCEL* by selecting the close button on the top right hand corner of this message, then the job will not proceed for nesting.

4. The *Unfold Imported Bodies* dialog box is displayed. All the imported parts with bends that constitute this assembly are listed Unfold tab of this dialog box. The faulty sheet metal part is highlighted in red colored font while the non-faulty part will be displayed in the default black colored font.

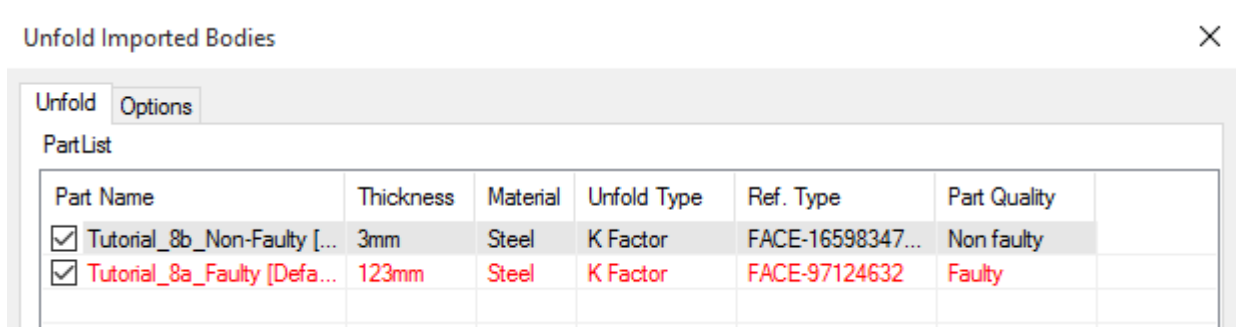

The 'Unfold Imported Bodies' dialog box

STEP 3: Selective unfolding of imported parts

As explained in Step 2, the '*Unfold Imported Bodies*' dialog box is used to facilitate the unfolding of imported sheet metal parts and associated parameters before proceeding with a nesting job.

Following are the steps to open the '*Unfold Imported Bodies*' dialog box to unfold the sheet metal parts and assign associated parameters:

1. Observe the *Part Quality* column in the *Unfolded Imported Bodies* dialog box. This column indicates which imported parts are faulty and which are non-faulty.



- Highlight the Faulty part in the Part List grid of this dialog box. Observe that a Status message is displayed in the bottom left hand corner of SOLIDWORKS.

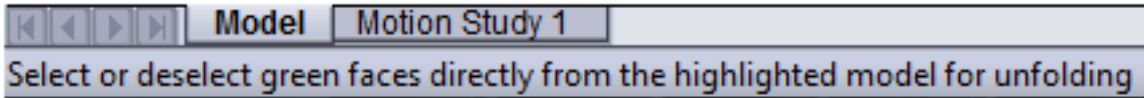

Status message displayed when a faulty part is highlighted in the 'Unfold Imported Bodies' dialog box

- In the graphics area, observe the faulty part. Notice that the certain bent edges of the faulty part are highlighted in green. Rotate the assembly so that the bottom surfaces are visible in order to get a clear view.
- In the graphics area, observe the faulty sheet metal part (Tutorial_8a_Faulty.SLDPRT). Notice that the certain bent edges of the faulty part are highlighted in green. All the faces tangentially connected to the reference face and will be highlighted in **dark green** colors on the faulty part. The default reference face for a part is always the surface with the largest area. This reference face is highlighted in **light olive green** color.

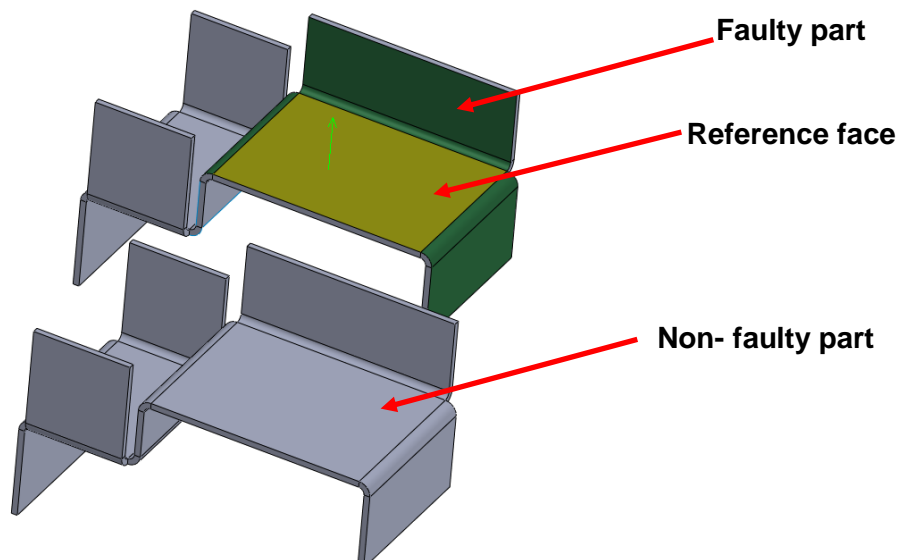

Tangentially connected faces highlighted in green on the faulty part

- As indicated by the status message, only the highlighted green faces in the faulty part will be processed for unfolding while non-faulty part(s) will be unfolded automatically.
- You can remove all the faces thus selected for unfolding by clicking on the reference face of the part in the graphics area. (The reference face is the one with the normal arrow and always highlighted in light olive green color). When you click on the highlighted reference face, all the selected faces, including the reference face, are discarded.

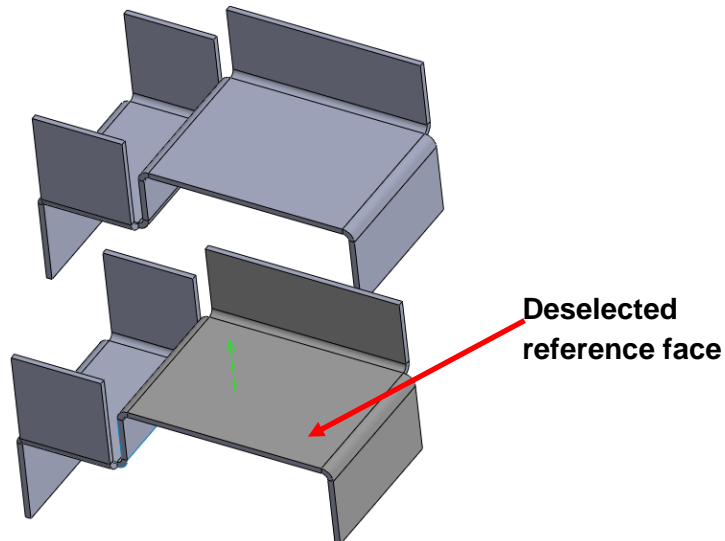

All highlighted green faces are deselected from unfolding when you click on the reference face

7. Observe the *Unfold Imported Bodies* dialog box. Since the faulty part no longer has a reference face, the Reference Face field in this dialog box displays a message prompting you to select a reference face on the part.

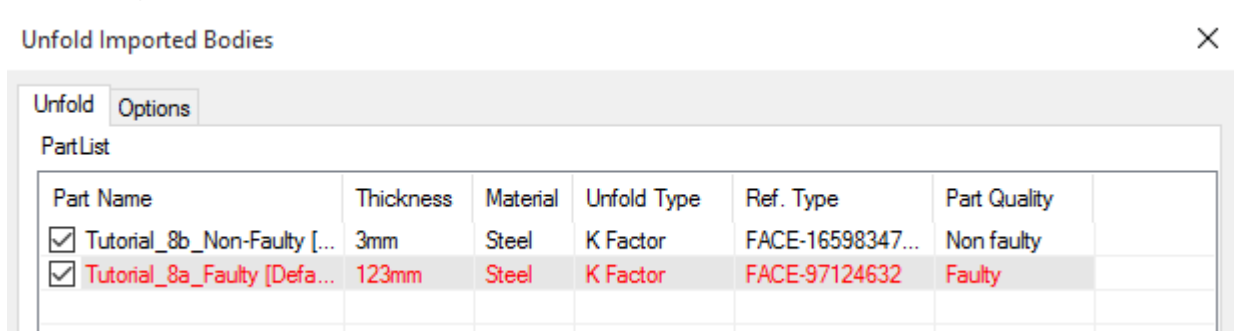

Message in Ref Face column prompting user to select a reference face

8. Rotate the part so that the top surfaces are once again visible. In the graphics area, pick the planar surface on the faulty part as shown in the image on the right. This planar surface will become the reference face (highlighted in light olive green color) for the faulty part. All the corresponding faces tangent to this reference face will be highlighted in green. Faces highlighted in green indicate that they will be unfolded.
9. If you select one of the highlighted green surfaces, then all the highlighted green faces which are adjacent to the selected face and also disconnected from the reference face will be discarded from unfolding.

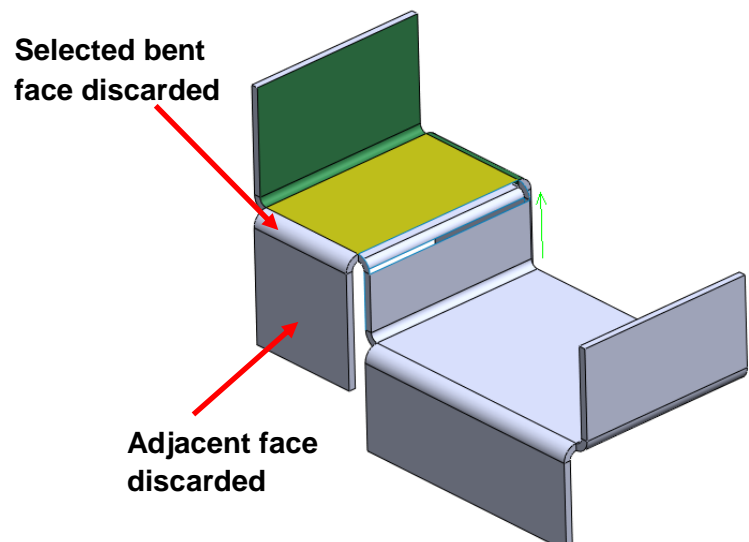



10. For example, click on the bend adjacent to the reference face as shown in the image on the left. Observe that this bent surface as well as the planar face that was adjacent and connected to it was discarded.

11. In the graphics area, click on the bent face of the faulty part that you deselected in the previous step. Observe that this face and its adjacent face (which was disconnected from the reference face) are once again highlighted.

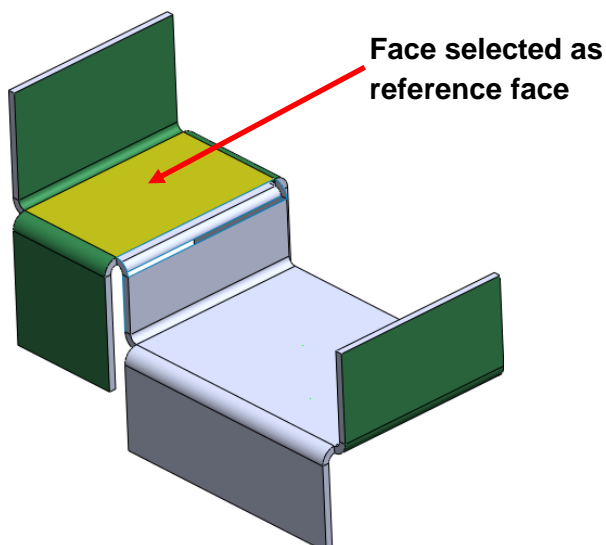
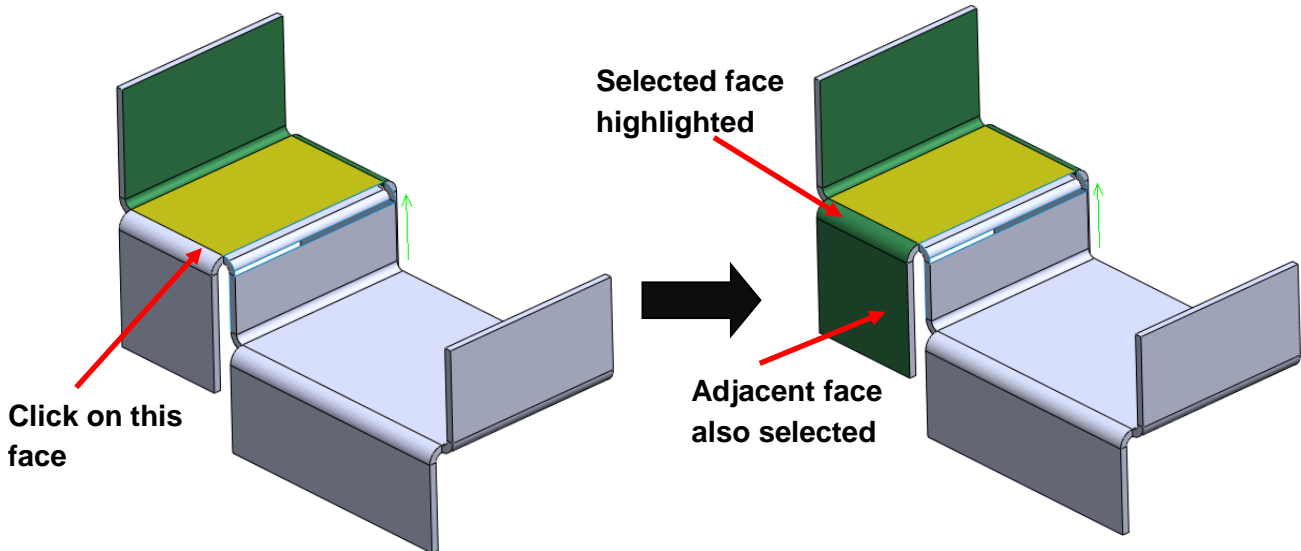
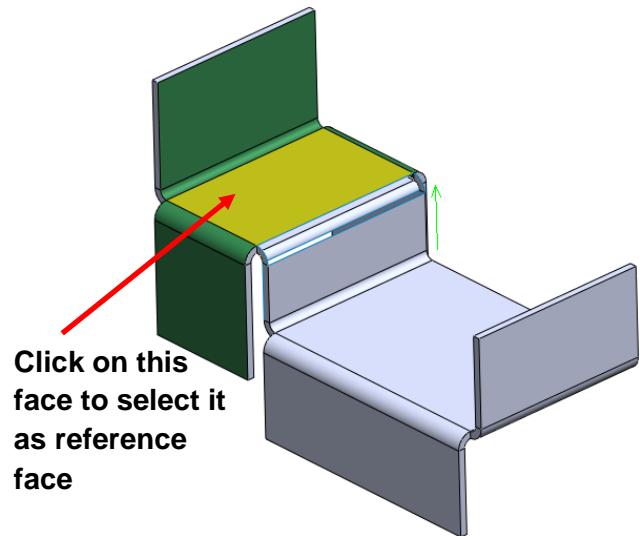

All highlighted green faces are deselected from unfolding when you click on the reference face



12. To add faces for unfolding to the set of green faces already highlighted, click on that desired face in the graphics area. This action also selects all faces tangent to the selected face for unfolding.

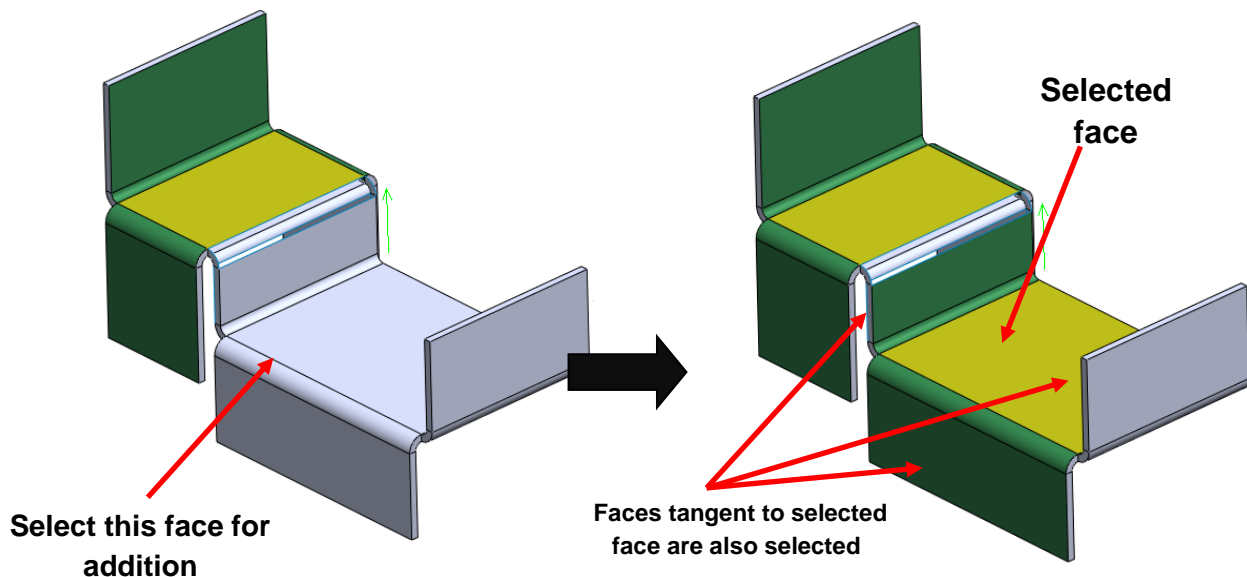

When you select a non-highlighted face for addition, all faces tangent to this face are also selected for unfolding

13. In the *Unfold Imported Bodies* dialog box, assign a thickness of **3mm** to the faulty part.
14. Click the OK button of this dialog box to unfold the imported parts. NESTINGWorks will check the imported parts for the number of disconnected face chains. If the selected part still retains more than one disconnected face chain, then an error message will be displayed prompting you to remove unwanted face chains. The parts won't be unfolded and the *Unfold Imported Bodies* dialog box will remain displayed.
15. The error message is displayed because two faces you selected as reference faces for the faulty part do not form a single face chain. The presence of a gap creates two face chains. For imported sheet metal parts, NESTINGWorks can unfold only a single face chain. If multiple disconnected face chains are manually selected by you, then this error message regarding the presence of multiple face chains will be displayed and the nesting process will not proceed further. Observe the non-faulty part. There is only a single face chain in this part.

For imported sheet metal parts containing bends which are to be unfolded before nesting, NESTINGWorks can only unfold any one single face chain. Multiple face chains cannot be unfolded and thereby cannot be nested.

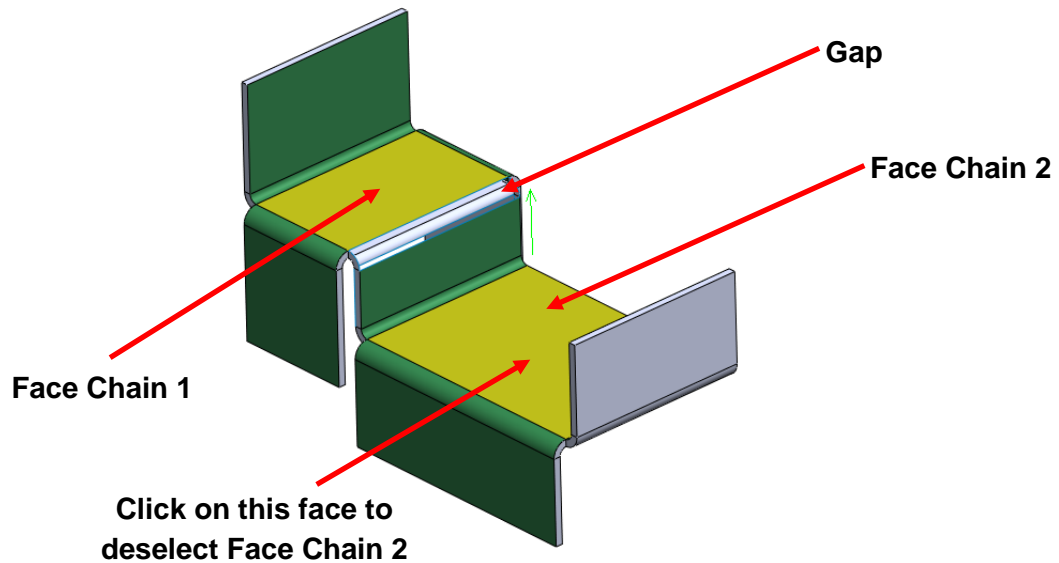

NESTINGWorks cannot unfold an imported sheet metal part with bends when multiple face chains are present

16. To proceed with nesting, you need to ensure that only one face chain is selected on the faulty part. Since there are two face chains present, deselect one of the face chains by clicking on face chain with the smaller reference area as shown in the above image.
17. Click on the OK button of the *Unfold Imported Bodies* dialog box. In the graphics area, observe that for the non-faulty imported part, its entire body is flattened. For the faulty part, only the faces highlighted in green are flattened.
18. Click on the *Create Nest Job* command on the NESTINGWorks Ribbon bar.
The *Select Parts for Nesting* Dialog Box will be displayed.
19. Place a tick in the checkbox adjacent to the *Parts* label to select all the listed parts.
20. Click the *OK* button.
21. The *Create Nesting Job* dialog box will be displayed. The parts selected in the previous dialog box will be displayed in *Part data* tab of this dialog box.

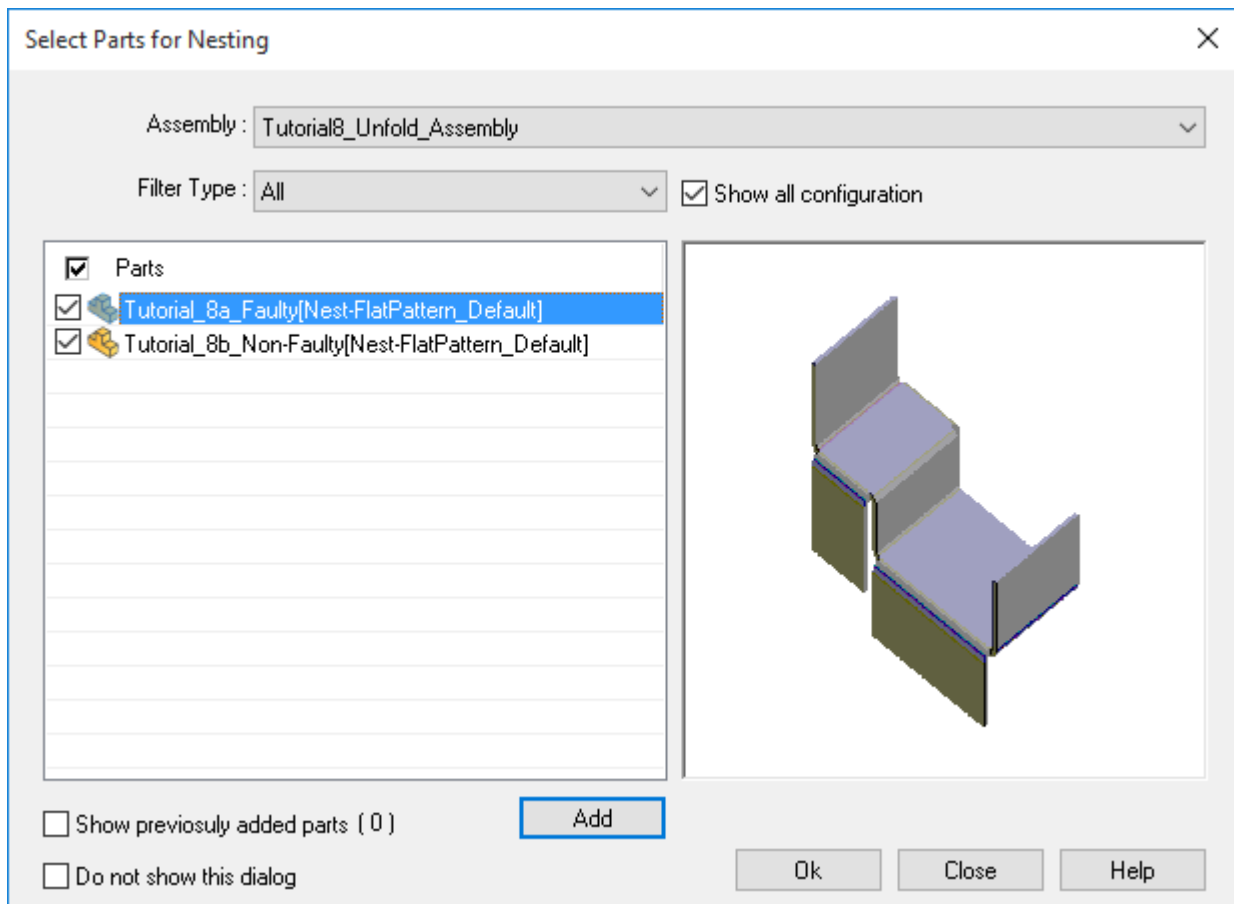

Select Parts For Nesting Dialog Box

STEP 4: Executing the Nesting Job

Part Data Tab

In the *Part data* tab of the *Create Nesting Job* dialog box, assign the following values to the parameters:

1. **Thickness & Material:** Observe that the Thickness and the Material of all the two parts are identical. These default values will remain unchanged. Identical thickness and material will enable nesting of these parts in the same sheet.
2. **Quantity:**
 - Assign a Quantity of **80** to part named *Tutorial_8a_Faulty*.
 - Assign a Quantity of **65** to part named *Tutorial_8b_Non-Faulty*.
3. **Step Angle:** Assign a Step Angle of **90 degrees** to both the parts.
4. **Grain Direction:** Leave the Grain direction set to *None* for both the parts.



Create Nesting Job

Part data | Sheet data | Multi head options | Options

Part list : Select parts for nesting

Assembly ▲	Part Name	Thickness	Quantity	Material	Rotation Type	Angle	Grain Direction
<input checked="" type="checkbox"/>	Tutorial8_Unf...		1				
<input checked="" type="checkbox"/>	Tutorial_8b_Non-Faul...	3mm	65	Steel	Step angle	90	None
<input checked="" type="checkbox"/>	Tutorial_8a_Faulty [N...	3mm	80	Steel	Step angle	90	None

Thickness : 3mm

Quantity : 1

Grain direction : None

Material : Steel

Normal face : CW ASM Face-3

Part size

X : 215.7mm

Y : 123mm

Part preview :

Rotation angle

Step angle 90

Part angle list 45,90

Restore Defaults | Preview Nest... | Cancel | Help

Part Data Tab

Sheet Data Tab

In this tutorial, we will use a customized sheet [Length = 2200mm; Width = 2200mm] to nest both the imported parts.

Click on the *Sheet data* tab of the *Create Nesting Job* dialog box and assign the following values to the parameters:

1. In the Sheet list grid, click on *Select to add sheet*.
2. **Thickness & Material:** By default, the thickness and material of the first part given in the Part list grid of the Part Data tab is assigned as the thickness and material in the Thickness (3mm) and Material (Steel) fields respectively. Leave these parameter values as it is.
3. **Quantity:** In the Quantity field, assign a quantity of 1.
4. **Grain Direction:** Leave the Grain direction set to *None*.



5. **Assembly Template:** Ensure that the Assembly Template is set to Default.
6. **Adding a Custom Sheet:** To add a Custom sheet,
 - Select Custom sheet from the sheet type dropdown list
 - Assign a length of **2200mm** in the Length field.
 - Assign a width of **2200mm** in the Width field
7. Click on the *Add sheet* button to add the sheet to the Sheet List.

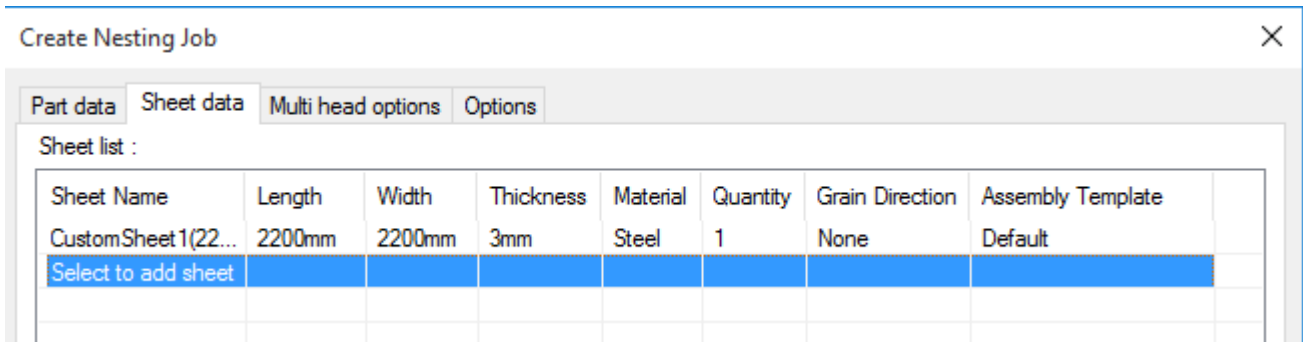

Sheet Data Tab of 'Create Nesting Job' dialog box

Nesting Parameters

Click on the *Options* tab of the *Create Nesting Job* dialog box and assign the following parameters:

1. Set a *Part to Part distance* of **10mm** and a *Part to Sheet distance* of **10mm**.
2. *Fast Nesting* is the default Nesting type.
3. Leave the *Create separate assembly* checkbox unchecked.
4. Click *Preview Nest...* button to preview the nested layout.
5. Click *Generate Nested Assembly* in the *Nesting Preview* window to execute the nesting process.

STEP 5: Generating the Nested Layout

Observe the Summary text file indicates that the prescribed quantities for all the parts have been nested within the sheet.

The nested layout assembly generated after executing the nesting job and the Summary Results file are stored in the folder location specified in the *Output assembly* field of the *Nesting Parameters* group box in the *Create Nesting Job* dialog box.

The nested layout is given on the next page.

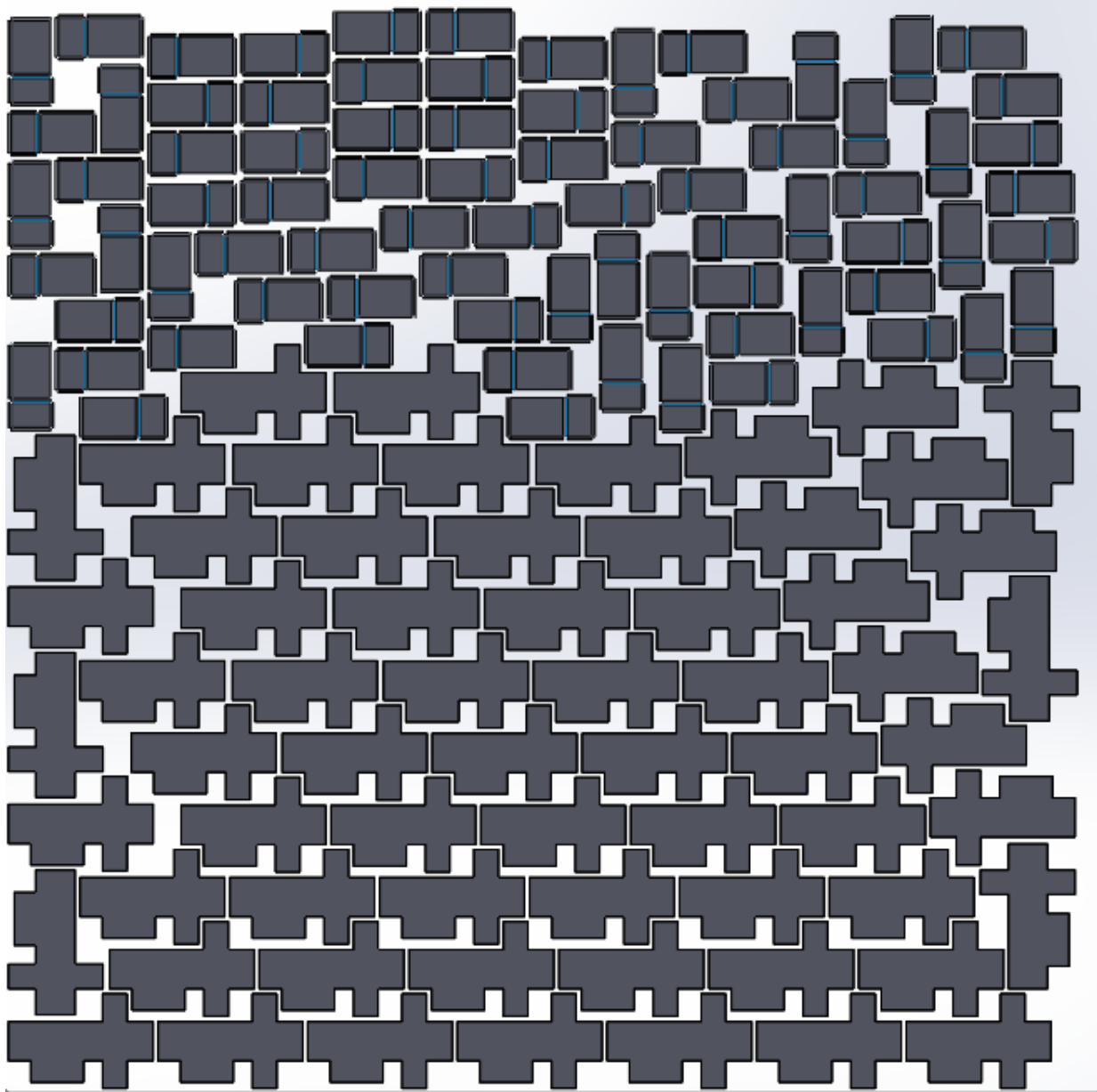

Nesting layout generated for the two sheet metal parts comprising the assembly



TUTORIAL 9 – ASSIGNING ASSEMBLY QUANTITIES

Introduction

NESTINGWorks provides a feature wherein, if an Assembly is to be nested, you can assign a quantity to the Assembly itself within the Part Data tab of the *Create Nesting Job* dialog box. Assigning the quantity to the assembly being nested automatically updates the quantities of its constituent parts. Thus, the need to assign quantity values to individual parts of the assembly is eliminated.

In this tutorial, you will explore how assigning quantity value to the assembly to be nested (or its constituent sub-assemblies) automatically updates the part quantity values.

Topic covered in this Tutorial:

- [Enabling the feature for Assigning Assembly Quantities](#)
- [Assigning Quantity value to the Assembly to be nested](#)
- [Assigning Quantity values to the sub-assemblies of the assembly](#)
- [Overwriting the quantities assigned automatically to the individual parts of an assembly with user-defined quantity values](#)

STEP 1: Open the Assembly

Open the assembly file **Parent Assembly.SLDASM** in the following folder location.
C:\ProgramData\NESTINGWorksData\NESTINGWorks 201Xx64\Examples\Tutorials\Assemblies\Tutorial9

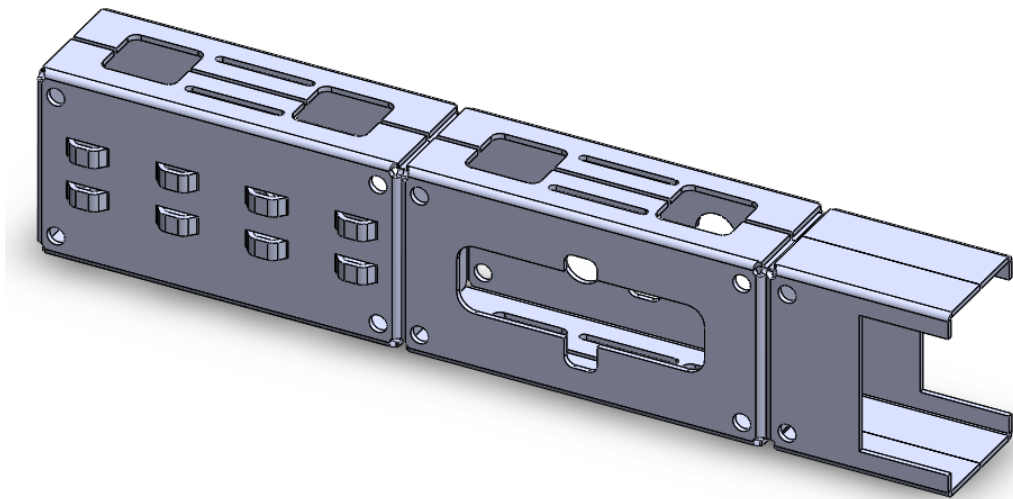

Parent Assembly.SLDASM



Components of the Parent Assembly

This Parent Assembly consists of:

- i. Assembly1
- ii. Assembly2
- iii. Part 4.

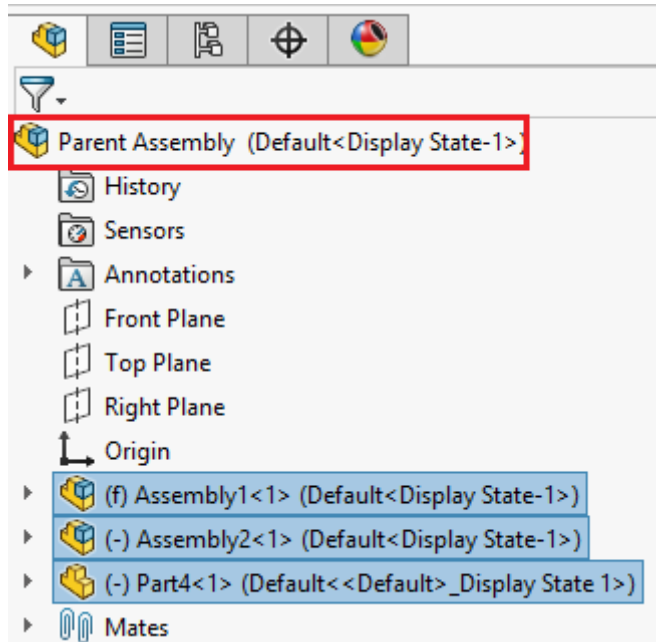

Parent Assembly in the FeatureManager Design tree

→ Assembly 1 comprises Part1 and Part2.

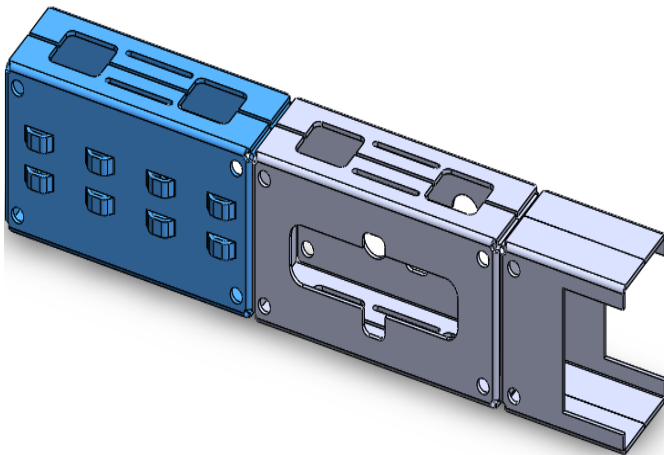

Components of Assembly1 highlighted on Parent Assembly

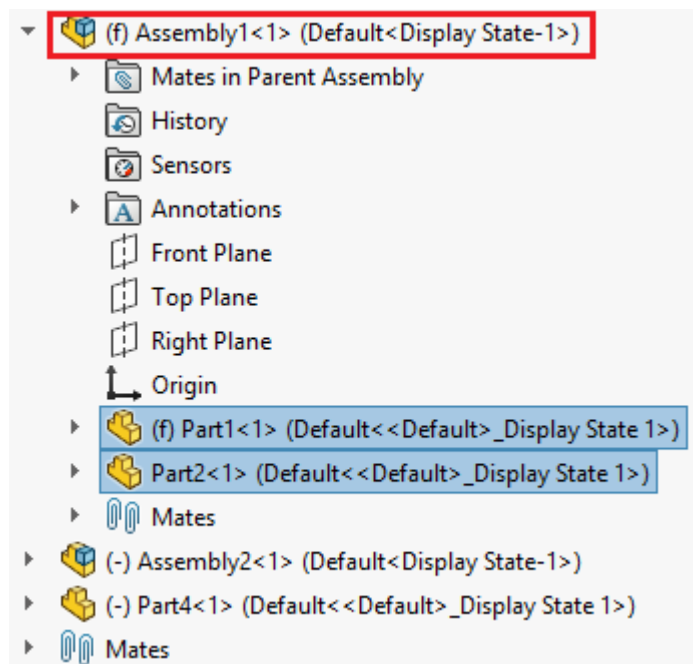

Assembly1 in FeatureManager Design tree



→ Assembly2 comprises Assembly3 and Part 3.

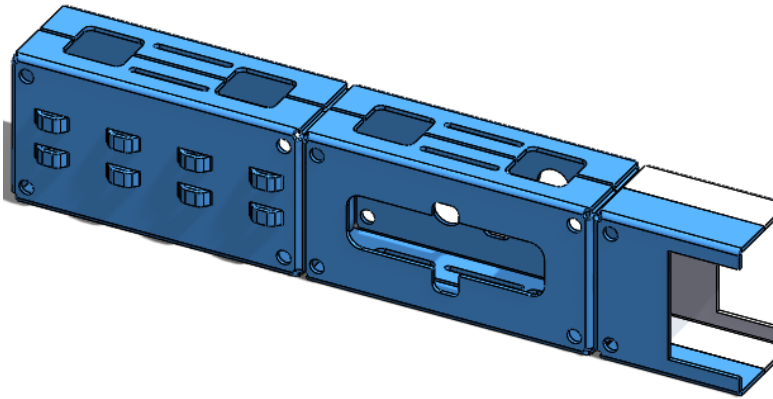

Components of Assembly2 highlighted on Parent Assembly

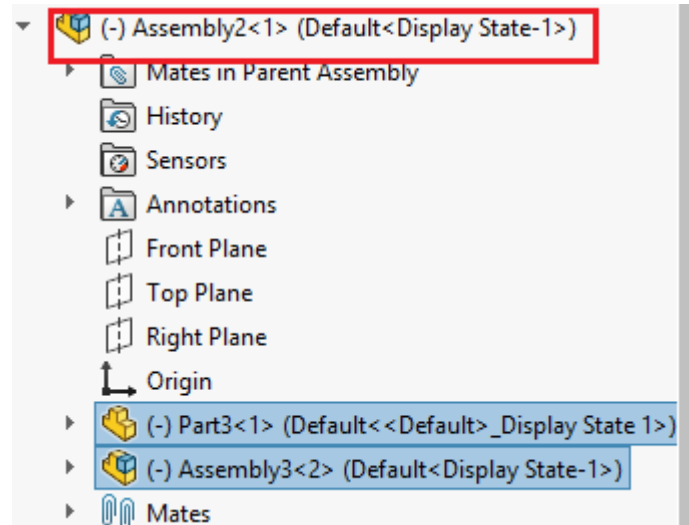

Assembly2 in FeatureManager Design tree

→ Assembly3 (sub-assembly of Assembly2) comprises Part1 and Part4.

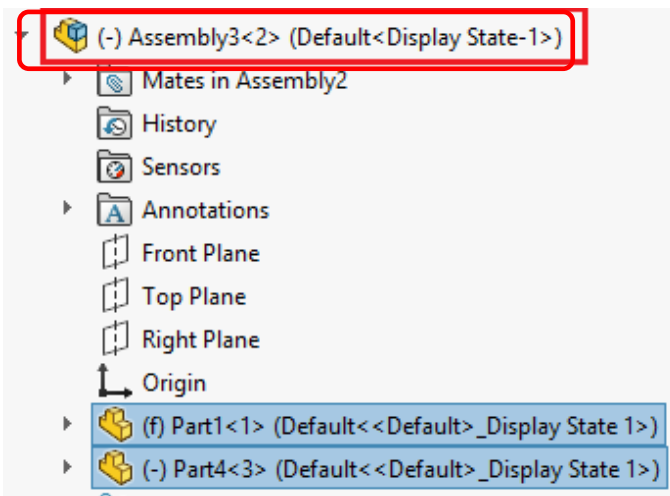

Assembly3 in FeatureManager Design tree

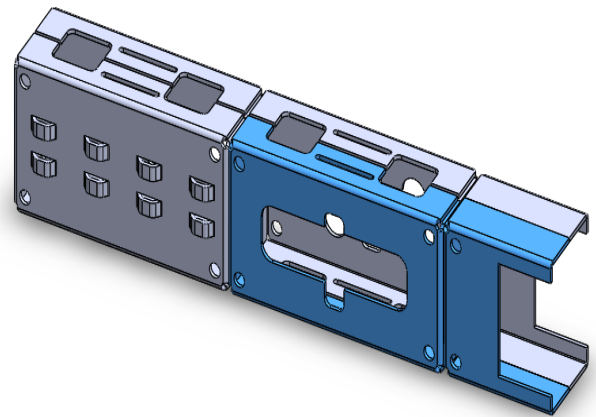

Components of Assembly3 highlighted on Parent Assembly



→ Part4 is a component of Parent Assembly as stated previously.

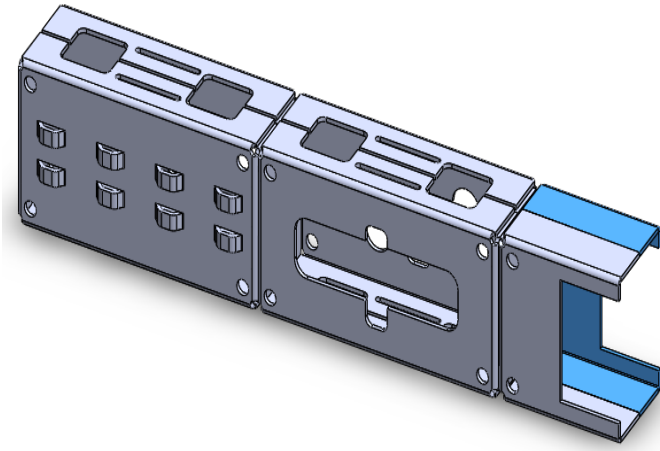

Part4 highlighted on Parent Assembly

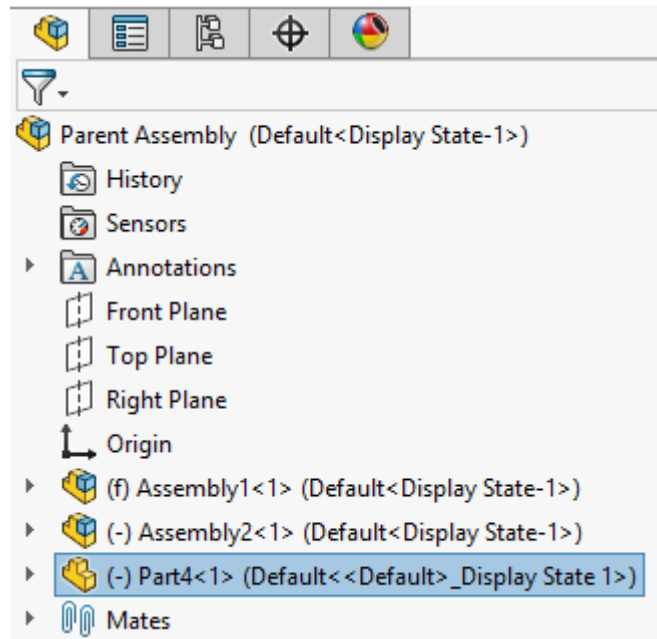

Part4 in FeatureManager Design tree

Thus, the Parent Assembly consists of the following sub-assemblies and parts:

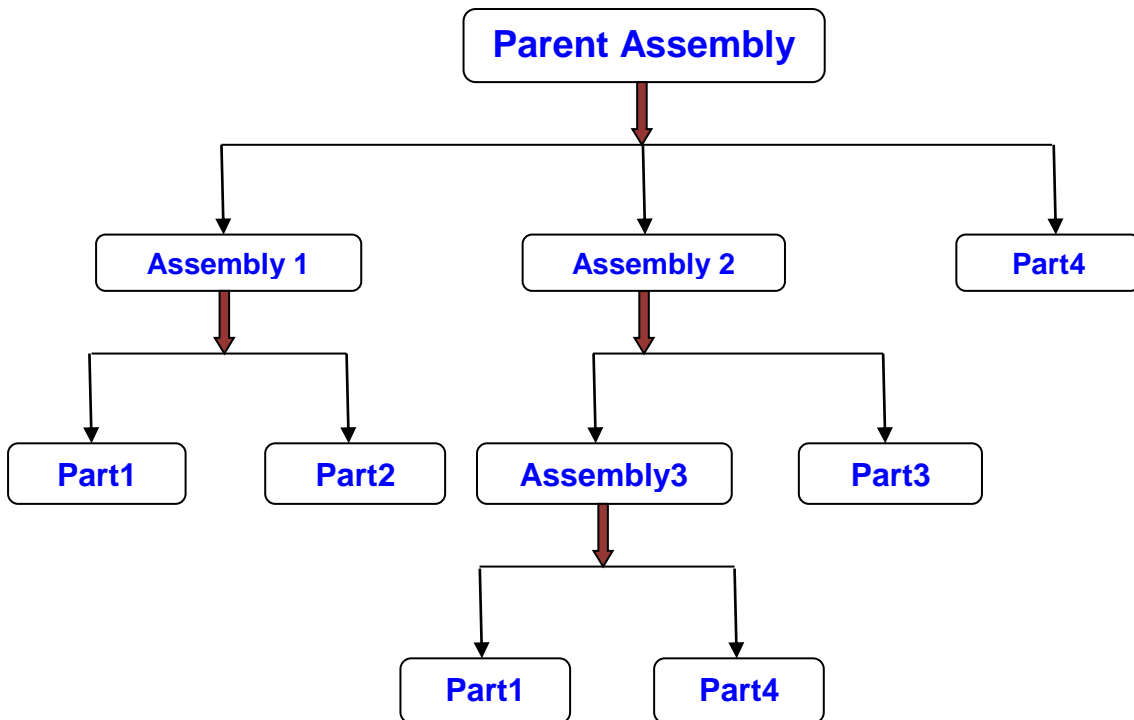

STEP 2: Enabling the option of flattening the sheet metal parts

The assembly to be nested (*Parent Assembly.SLDASM*) consists of sheet metal parts. These sheet metal parts need to be unfolded before executing the nesting job. To nest these sheet metal parts based on its dimensions after flattening, the option for flattening (unfolding) sheet metal parts needs to be configured in the *DefaultValues.ini* file explained in



NESTINGWorks Configuration Files and Associated Settings Guide. If you are unsure about the settings, open the *DefaultValues.ini* file and set the *FlattenSheetMetalPart* flag to '1' in order to activate the option of flattening.

STEP 3: Enabling the feature for Assigning Assembly Quantities

To assign quantity value to the assembly is to be nested (Parent Assembly.sldasm), the feature for assigning Assembly Quantities needs to be enabled in in the **DefaultValues.ini** file explained in *NESTINGWorks Configuration Files and Associated Settings Guide*. If you are unsure about the settings, open the *DefaultValues.ini* file and set the *ShowAssemblyQuantity* flag to '1' to [enable the feature of Assigning Assembly Quantities](#).

STEP 4: Execute the 'Create Nest Job' command

1. In the NESTINGWorks cascading menu, ensure that the *Enable Auto Unfold* option is checked.

Activating this option ensures that sheet metal components to be nested are automatically unfolded based on their dimensions before executing the nesting job.

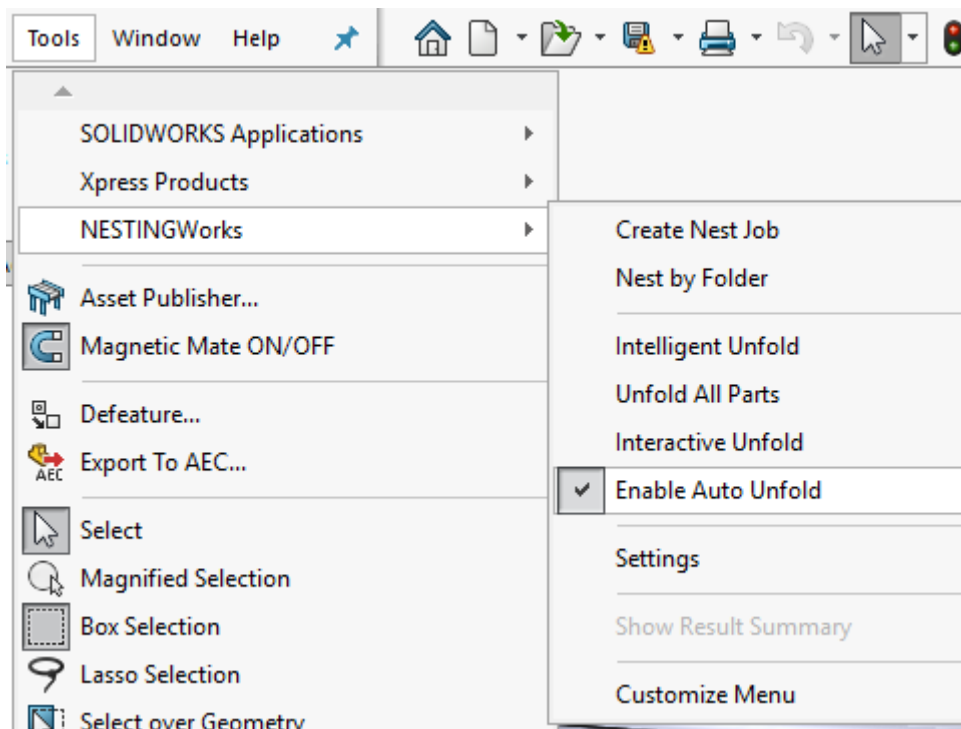

'Enable Auto Unfold' option checked in the NESTINGWorks cascading menu

2. Execute the *Create Nest Job* command on the NESTINGWorks Ribbon bar or NESTINGWorks cascading menu.

The *Select Parts for Nesting* dialog box will be displayed.

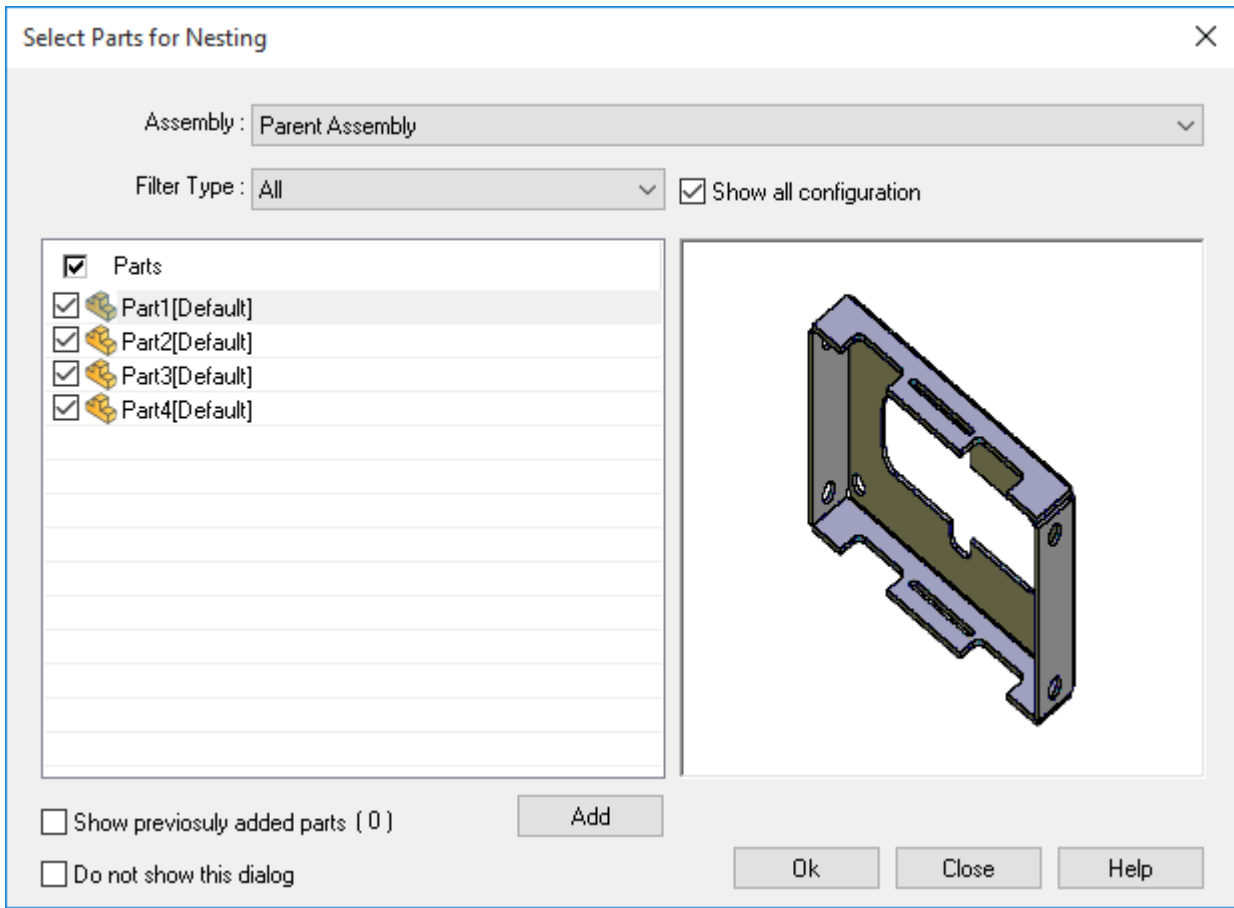

‘Select Parts For Nesting’ Dialog Box

3. Place a tick in the checkbox adjacent to the *Parts* label in order to select all the listed parts and click the OK button.
4. The *Create Nesting Job* dialog box will be displayed.

Observe that the parent assembly (*Parent Assembly.sldasm*), its sub-assemblies as well as the parts comprising these sub-assemblies have been listed in the *Part Data* tab in the *Create Nesting Job* dialog box.

Assembly Column

The Parent Assembly and its sub-assemblies are listed in the **Assembly column** of the Part List in alphabetical order. The quantity of the *Parent Assembly* and its sub-assemblies are listed in the **Quantity column**.

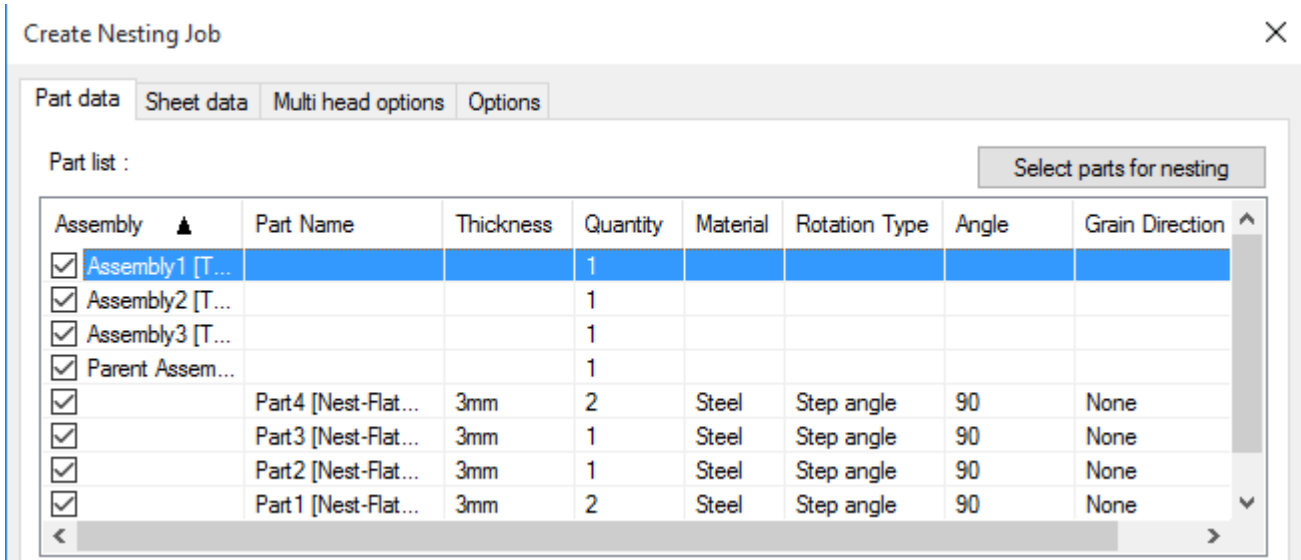

Parent Assembly and sub-assemblies listed in the Part List grid of Part Data tab

Part name column

Use the vertical scroll bar to scroll down the Part List. Observe that the parts constituting the Parent assembly and sub-assemblies are listed in the *Part name* column along with associated parameters of *Thickness*, *Quantity*, *Material*, *Rotation type*, *Angle*, etc.

Quantity Column

Observe the Quantity column. The number of instances each sub-assembly and part appears in the Parent assembly is listed. In the Quantity column, ensure that the Quantity for Parent Assembly is '1'. (If it isn't, double-click on this field in the *Part list* grid and assign a quantity of '1'.)

When the quantity for Parent assembly is '1', the quantity of its constituent sub-assemblies and parts will be as follows:

<u>Name</u>	<u>Quantity</u>
Parent Assembly	1
Assembly1	1
Assembly2	1
Assembly3	1
Part1	2
Part2	1
Part3	1
Part4	2



STEP 5: Changing the quantity of the Parent assembly

1. In the *Part list* grid, double-click on the Quantity field for Parent Assembly and change the Quantity to '20'. Press the Tab button to shift the focus.

Observe that the Quantity values of all the constituent sub-assemblies and parts were automatically updated to reflect new values based on the Parent Assembly.

<u>Name</u>	<u>Original Quantity</u>	<u>New Quantity</u>
Parent Assembly	1	20
Assembly1	1	20
Assembly2	1	20
Assembly3	1	20
Part1	2	40
Part2	1	20
Part3	1	20
Part4	2	40

Create Nesting Job ×

Part data | Sheet data | Multi head options | Options

Part list : Select parts for nesting

Assembly ▲	Part Name	Thickness	Quantity	Material	Rotation Type	Angle	Grain Direction ^
<input checked="" type="checkbox"/>	Assembly1 [T...		20				
<input checked="" type="checkbox"/>	Assembly2 [T...		20				
<input checked="" type="checkbox"/>	Assembly3 [T...		20				
<input checked="" type="checkbox"/>	Parent Assem...		20				
<input checked="" type="checkbox"/>	Part4 [Nest-Flat...	3mm	40	Steel	Step angle	90	None
<input checked="" type="checkbox"/>	Part3 [Nest-Flat...	3mm	20	Steel	Step angle	90	None
<input checked="" type="checkbox"/>	Part2 [Nest-Flat...	3mm	20	Steel	Step angle	90	None
<input checked="" type="checkbox"/>	Part1 [Nest-Flat...	3mm	40	Steel	Step angle	90	None

Part Data Tab

Analysis

- Assembly1 and Assembly2:** Both *Assembly1* and *Assembly2* have one instance each in the Parent Assembly. Hence, when the quantity of the Parent Assembly is updated, the quantity of this sub-assembly too will be updated to the same value.
- Assembly3:** *Assembly3* has one instance in *Assembly2* which in turn has one instance in the Parent Assembly. Hence, when the quantity of the Parent Assembly is updated, the quantity of this sub-assembly too will be updated to the same value.



- iii. **Part1:** This part has one instance in *Assembly1* and another instance in *Assembly3*. Hence, two instances of *Part1* occur within the Parent Assembly. Hence, when the quantity of the Parent Assembly is updated, the quantity of *Part1* will be updated to double of the Parent Assembly's quantity value.
- iv. **Part2:** This part has one instance in *Assembly1* which in turn has one instance in the Parent Assembly. Hence, when the quantity of the Parent Assembly is updated, the quantity of *Part2* will be updated to the same value as that of the Parent Assembly.
- v. **Part3:** This part has one instance in *Assembly3* which has one instance in *Assembly2* and which in turn has one instance in the Parent Assembly. Hence, when the quantity of the Parent Assembly is updated, the quantity of *Part3* will be updated to the same value as that of the Parent Assembly.
- vi. **Part4:** This part has one instance in *Assembly2* and another instance in the Parent Assembly. Hence, two instances of *Part4* occur within the Parent Assembly. Hence, when the quantity of the Parent Assembly is updated, the quantity of *Part4* will be updated to double of the Parent Assembly's quantity value.

Thus, if you change the quantity of the assembly to be nested, then the quantity of all its constituent sub-assemblies and parts will be automatically updated to values in sync with quantity of the assembly.

This feature eliminates the need to assign individual quantities to the constituent parts.

STEP 6: Changing the Quantity of a sub-assembly

1. In the *Part list* grid, double-click on the Quantity field for *Assembly2* and change the Quantity to '22'. Press the *Tab* button to shift the focus.

Observe that the Quantity values for *Assembly3*, *Part1*, *Part3* and *Part4* were automatically updated to reflect new values based on the quantity of *Assembly2*.

<u>Name</u>	<u>Original Quantity</u>	<u>New Quantity</u>
Parent Assembly	20	20 (unchanged)
Assembly1	20	20 (unchanged)
Assembly2	20	22 (updated)
Assembly3	20	22 (updated)
Part1	40	42 (updated)
Part2	20	20 (unchanged)
Part3	20	22 (updated)
Part4	40	42 (updated)



Create Nesting Job ×

Part data | Sheet data | Multi head options | Options

Part list : Select parts for nesting

Assembly ▲	Part name	Thickness	Quantity	Material	Rotation type	Angle	Grain direction
<input checked="" type="checkbox"/>	Assembly1 [T...		20		Step angle	90	
<input checked="" type="checkbox"/>	Assembly2 [T...		22		Step angle	90	
<input checked="" type="checkbox"/>	Assembly3 [T...		22				
<input checked="" type="checkbox"/>	Parent Assem...		20		Step angle	90	
<input checked="" type="checkbox"/>	Part4 [Nest-Flat...	3mm	42	Steel	Step angle	90	None
<input checked="" type="checkbox"/>	Part3 [Nest-Flat...	3mm	22	Steel	Step angle	90	None
<input checked="" type="checkbox"/>	Part2 [Nest-Flat...	3mm	20	Steel	Step angle	90	None
<input checked="" type="checkbox"/>	Part1 [Nest-Flat...	3mm	42	Steel	Step angle	90	None

Part Data Tab

Analysis

- i. **Assembly1:** *Assembly1* is not a component of *Assembly2*. Hence, its Quantity value will remain unchanged.
- ii. **Assembly3:** Within the Parent Assembly, the sub-assembly named *Assembly3* has only one instance - as component of *Assembly2*. Hence, when the quantity of the *Assembly2* is updated, the quantity of this sub-assembly too will be updated to the same value.
- iii. **Part1:**
Part1 has 20 instances in *Assembly1* and 20 instances in *Assembly3* → 20 +20 = **40**.
Assembly1 is not a component of *Assembly2* and hence, the first 20 instances will remain unchanged.
 However, *Assembly3* has once instance in *Assembly2*. Hence, when the quantity of *Assembly2* is updated from '20' to '22', the quantity of *Assembly3* will be updated to '22'. Since *Part4* has one instance in *Assembly3*, the quantity component will be updated to '22'.
 The updated Quantity value for *Part1* will be 20 instances in *Assembly1* and 22 instances in *Assembly3* → 20+22 = **42**.
- iv. **Part2:** *Part2* is not a component of *Assembly2*. Hence, its Quantity value will remain unchanged at '**20**' instances.
- v. **Part3:** This part has 20 instances in *Assembly3* which in turn has 20 instances in *Assembly2*. Hence, when the quantity of *Assembly2* is updated to '22', the quantity of *Part3* will be updated to the same value as that of the *Assembly2*.
 Thus, the updated Quantity value for *Part3* will be **22** instances in *Assembly3*.
- vi. **Part4:** *Part4* has 20 instances in the *Parent Assembly* and 20 instances in *Assembly2* → 20 +20 = **40**.
 Since the Parent Assembly is not a component of *Assembly2*, the first 20 instances will remain unchanged.



However, the next 20 instances are in Assembly2. Hence, when the quantity of Assembly2 is updated from '20' to '22', the quantity of Part4 will also be updated to '22'.

The updated Quantity value for Part4 will be 20 instances in Parent Assembly and 22 instances in Assembly2 → 20+22 = 42.

Note: If you change the quantity of a sub-assembly listed in the Part List grid of the Part Data tab, then only the quantities of its constituent sub-assemblies and parts will be updated. The quantities of parts/assemblies which are not a component of this sub-assembly will remain unchanged.

STEP 7: Changing the Quantity of Parent Assembly

- 1. In the Part list grid, double-click on the Quantity field for Parent Assembly and change the quantity to '10'. Press the Tab button to shift the focus.

Observe that the quantity values of all the constituent sub-assemblies and parts were automatically updated to reflect new values based on the Parent Assembly.

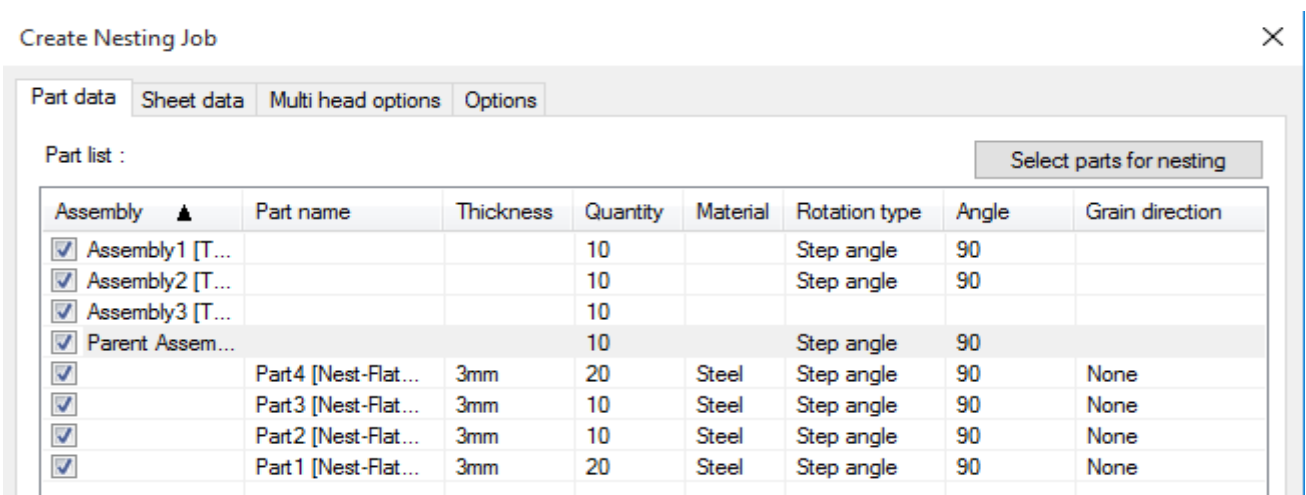

Updated result of Parts

<u>Name</u>	<u>Quantity</u>
Parent Assembly	10
Assembly1	10
Assembly2	10
Assembly3	10
Part1	20
Part2	10
Part3	10
Part4	20



Note: If you change the quantity of the Parent assembly, then the quantity of its constituent sub-assemblies and parts will be recalculated and automatically updated.

STEP 8: Overwriting automatically assigned Quantity values for Parts with user-defined values

NESTINGWorks executes all nesting jobs based on the quantity of the parts in the Part Data tab (and not based on the quantity of the Assembly). This is the reason why, when you assign a quantity to an assembly in the **Part Data** tab, the quantity of its constituent parts are updated.

Even when the feature for Assigning Assembly Quantities is active, you can assign user-defined quantity values to the individual parts in the Part List grid at any point of time.

1. Double-click on the Quantity field for each of the four parts in the Part list grid and assign a quantity of '15' to each part.

If you proceed further with the nesting job, the quantity considered will be based on these user-defined values of the parts.

2. Assign a quantity of '10' to the Parent Assembly. Observe that the quantity of all the sub-assemblies and parts are updated to the values given in [Step 7](#).

Note: You can update the Part quantities with user-defined quantity values at any point of time even if the feature for assigning assembly quantities is active. However, your user-defined values will be overwritten with automatically assigned values if you once again assign quantity values to the assembly constituting the parts.

STEP 9: Deactivating the feature of assigning assembly quantities

Observe the Assembly column of the *Part list* grid of the *Part data* tab. The arrow mark pointing upwards indicates that the feature for Assigning Assembly Quantities is currently active.

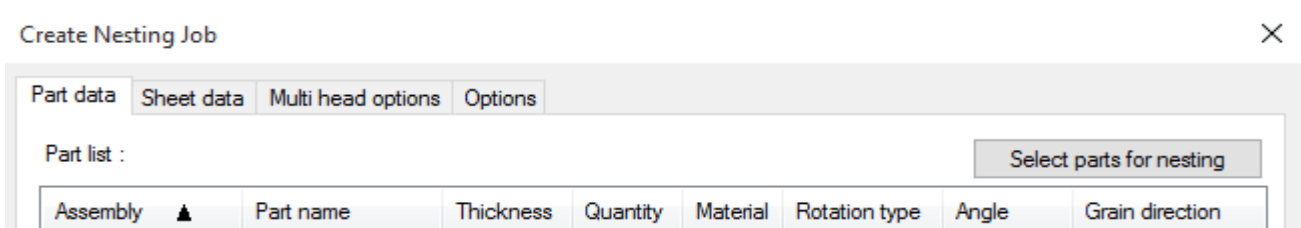

Arrow mark in the Assembly column pointing upwards

If the [feature for assigning assembly quantities is enabled](#) in the DefaultValues.ini file, then, whenever you open the *Create Nesting Job* dialog box, the arrow mark in the Assembly column of the Part list grid will point upwards indicating that the feature is currently active.



Deactivating the feature only for the current nesting job

Left-click on the *Assembly column* heading. Observe that the arrow mark in the Assembly column now points downwards. The Part list no longer displays any assembly in the Assembly column. This column will be empty. Only parts constituting the assembly will be listed in the *Part list* grid. The arrow pointing downwards indicates the feature for assigning assembly quantities is currently inactive.

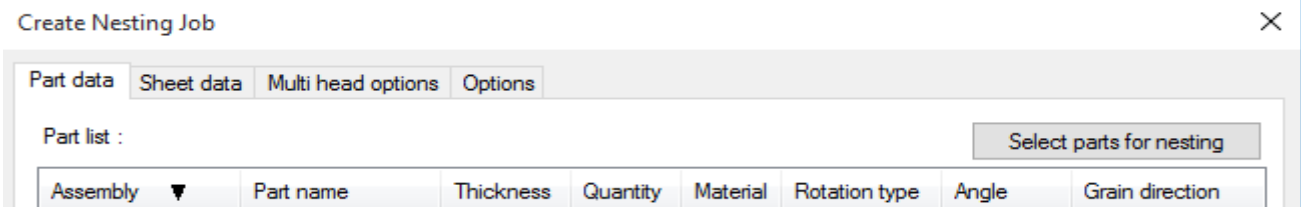

Arrow mark in the Assembly column pointing downwards

If you do not wish to use the feature of assigning assembly quantities for a particular nesting job, then deactivate this feature temporarily only the current job by having the arrow mark in the *Assembly column* point downwards.

Deactivating the feature for all nesting jobs

1. If you work primarily with parts rather than assemblies or if you prefer assigning user-defined quantities to the part of an assembly, you might consider disabling the feature of assigning assembly quantities.
2. To [disable the feature of assigning assembly quantities](#), set the *ShowAssemblyQuantity* flag in the *DefaultValues.ini* file to '0' and exit after saving the new settings.

With the feature disable, the next time you open the *Create Nesting Job* dialog box in order to nest an assembly, the *Assembly column* will not be displayed at all in the *Part data* tab. Only the parts comprising the assembly will be listed.

3. You can enable this feature again by setting the *ShowAssemblyQuantity* flag in the *DefaultValues.ini* file back to '1'.

Note: When the feature for assigning assembly quantities is disabled, the Assembly column will not be displayed in the Part list grid of the Part data tab within the 'Create Nesting Job' dialog box.

Complete the nesting job by assigning the remaining Part parameters, Sheet parameters and Nesting data parameters.



TUTORIAL 10 – UNFOLDING SHEET METAL COMPONENTS USING ‘INTERACTIVE UNFOLD’ COMMAND

Introduction

The ‘Interactive Unfold’ Command

The ‘Interactive Unfold’ command is a means to selectively unfold faces of parts with bends before nesting the parts. This is done by providing a reference face and selecting faces to unfold either automatically or manually with respect to the reference face. Both native as well as imported parts can be unfolded using this command.

Difference between the various Unfold commands

Given below is table of comparison highlighting the difference in the way a part is unfolded using the various Unfold commands.

	Intelligent Unfold Command	Unfold All Parts Command	Interactive Unfold Command	Create Nest Job Command
Faulty Native Part				
Non-Faulty Native Part				
Faulty Imported Part				
Non-Faulty Imported Part				

Legend:

	User can change the default reference face and define the chain of faces to unfold.
	User can change the default reference face but cannot define chain of faces to unfold.
	Command not applicable to native parts
	Opens the dialog box associated with ‘Intelligent Unfold’.
	Part is unfolded using SOLIDWORKS functionality



The 'Chain Faces' option for Unfold commands

The **Chain Faces** is a checkbox option present in the Unfold dialog box of all Unfold commands.



Chain Faces Option in Unfold dialog box

- When this checkbox option is enabled, all faces connected tangentially to the reference face are automatically selected.
- When this checkbox option is disabled, faces connected tangentially to the reference face will not be automatically selected. You need to manually select each face to be unfolded.

If the Chain Faces option is enabled/disabled at any point of time during the unfolding process, then the changed settings for this option are applicable for all further selections. However, the faces already selected/deselected will not be affected.

Topic covered in this Tutorial:

This tutorial explains how to selectively unfold imported and native 3D sheet metal parts with non-faulty bodies using the 'Interactive Unfold' command. The tutorial explores

- [Using the 'Interactive Unfold' with the 'Chain Faces' option enabled](#)
- [Using the 'Interactive Unfold' with the 'Chain Faces' option disabled](#)

STEP 1: Open the Assembly

Open the assembly file **Tutorial10_Interactive_Unfold.SLDASM** in the following folder location.

C:\ProgramData\NESTINGWorksData\NESTINGWorks 201Xx64\Examples\Tutorials\Assemblies\Tutorial10

This assembly comprises of two different sheet metal parts:

- i. InteractiveUnfold_Native.SLDPRT **(Native Part)**
- ii. InteractiveUnfold_Imported.SLDPRT **(Imported Part)**

Both the parts have non-faulty bodies.

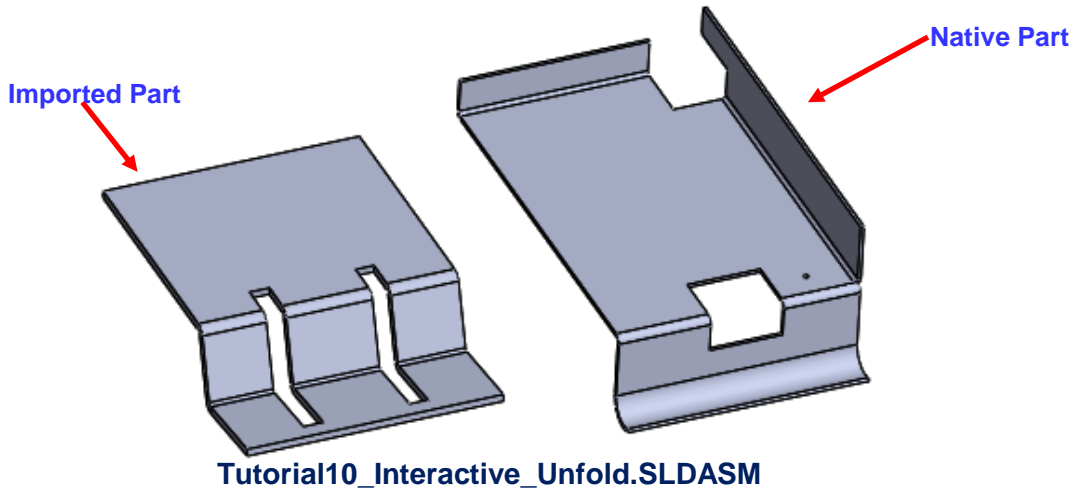

STEP 2: Executing the 'Interactive Unfold' command

1. Click on the *Interactive Unfold* command in the NESTINGWorks menu . Alternatively, click on the *Interactive Unfold* button on the NESTINGWorks Ribbon Bar.

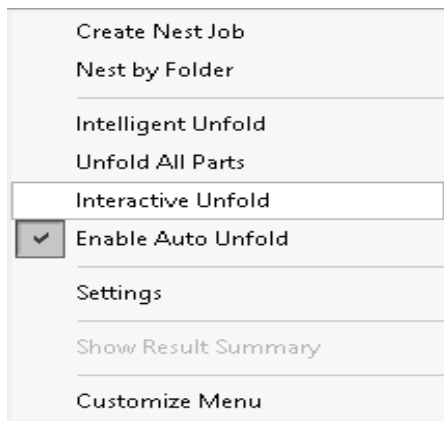

'Interactive Unfold' command in NESTINGWorks menu

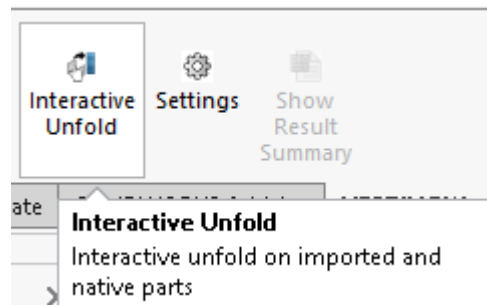

'Interactive Unfold' button in the NESTINGWorks Ribbon Bar

2. NESTINGWorks will display a message stating that you will need to select/deselect faces directly on the model for unfolding.

- Click *OK* to close the message box and proceed with unfolding.
- If you don't wish to see this warning message again in future nesting jobs, select the checkbox ***Don't show this message again*** before you click *OK*.

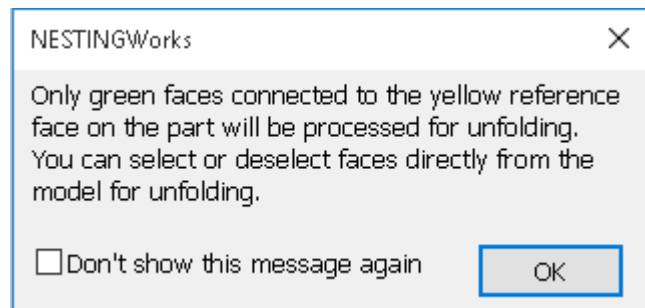

NESTINGWorks Message



- If you click *CANCEL* by selecting the close button  on the top right hand corner of the message box, then the job will not proceed for nesting.
3. When you click the *OK* button in the message, the Interactive Unfold dialog box is displayed. All the parts comprising the assembly (both native and imported) are listed in the Part List grid of this dialog box.
Since the assembly used in this tutorial consists of one imported part and one native part, both are listed in the Part List grid.
 4. If you do not wish to unfold any particular part listed in the Part List grid, you can deselect the part from unfolding by unchecking the checkbox next to the part name in the Part List grid.
 5. In this tutorial, you will unfold the listed parts. Hence, both the checkboxes indicating the parts to be unfolded will remain checked.

STEP 3: Selective Unfolding of Parts when ‘Chain Faces’ option is enabled

1. Highlight part in the *Part List* grid of the *Interactive Unfold* dialog box. Observe that a Status message is displayed in the bottom left corner of the Status bar of SOLIDWORKS.

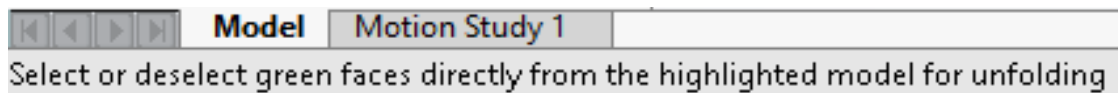

Status message displayed when a part is highlighted in the ‘Interactive Unfold’ dialog

2. In the Interactive Unfold dialog box, the non-faulty native part is listed in the Part List grid and will be processed through selective unfolding.

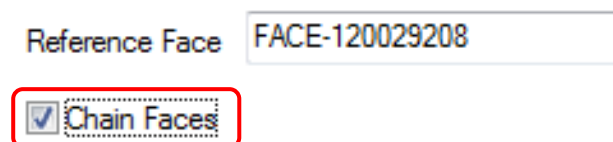

Chain Faces in Interactive Unfold dialog

3. In the graphics area, observe that a reference face (yellow color) and faces connected tangentially (green color) to the reference face are highlighted automatically on both the imported and native parts, thus indicating the faces to be unfolded.

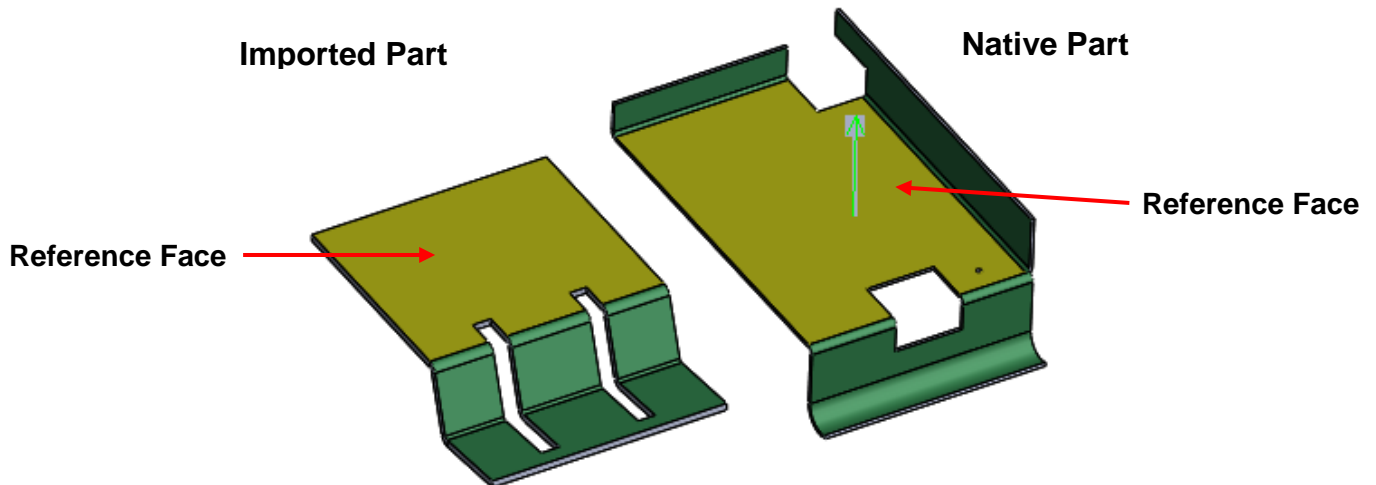

Reference Faces and Faces tangentially connected to the reference face highlighted in Yellow and Green color respectively

Deselecting/ Selecting the faces to be unfolded

Faces of the part which are selected for unfolding are highlighted in **green color** when the *Interactive Unfold* dialog box is open. If you wish to deselect such a face from being unfolded, then you need to mouse click on that face of the part in the graphics area.

- When you deselect a green-colored face, then all the faces which are adjacent to the deselected face but now disconnected from the reference face due to this deselection will also be deselected automatically.
- Similarly, when you select an unselected face, all the faces adjacent to it that now connected to the reference face due to the selection will be selected automatically. Their selection is indicated by green color highlights.

This feature of automatic selection/deselection of faces is possible only when the *Chain faces* option is enabled.

In this section, we will explore the selection/deselection of the faces to be unfolded when the *Chain Faces* option is enabled.

Consider the native part of the assembly in this tutorial in its default selection state. For the purposes of illustration the various faces have been labeled as given below.

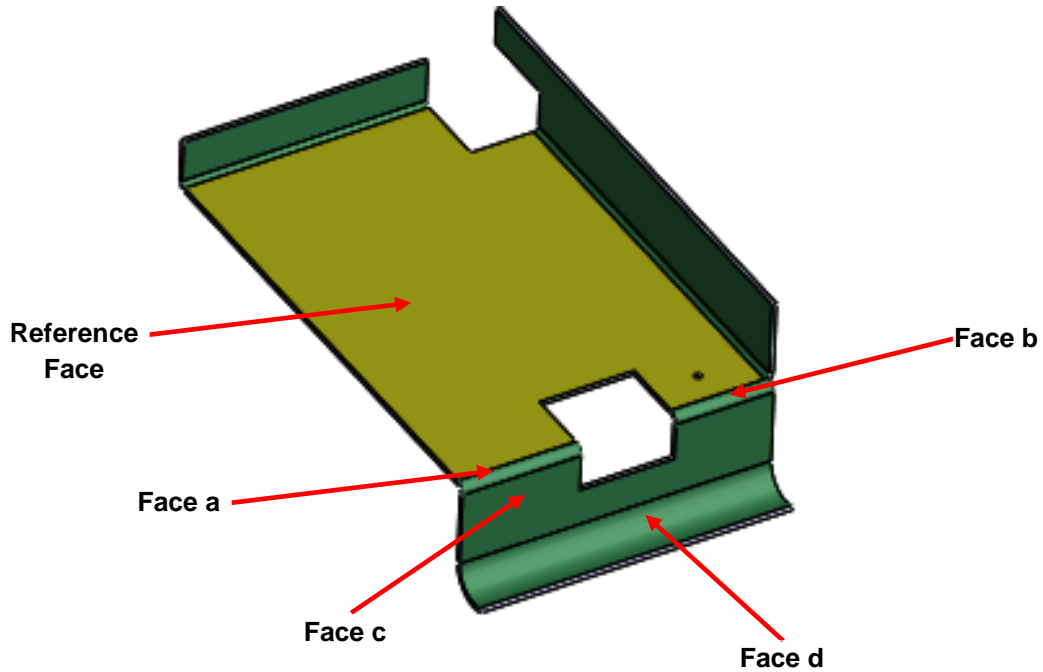

The following illustrations explain how to select/deselect faces to be unfolded.

Illustration 1:

- i. On the native part, click on **Face d** as shown in the image on the right.
- ii. Observe that only **Face d** is deselected. The only face adjacent to **Face d** is **Face c**. However, **Face c** is not deselected and continues to be highlighted in green indicating its selection for unfolding. This is because it continues to be connected to the Reference face via **Face a** and **Face b**.
- iii. Click on **Face d** again in order to select it.

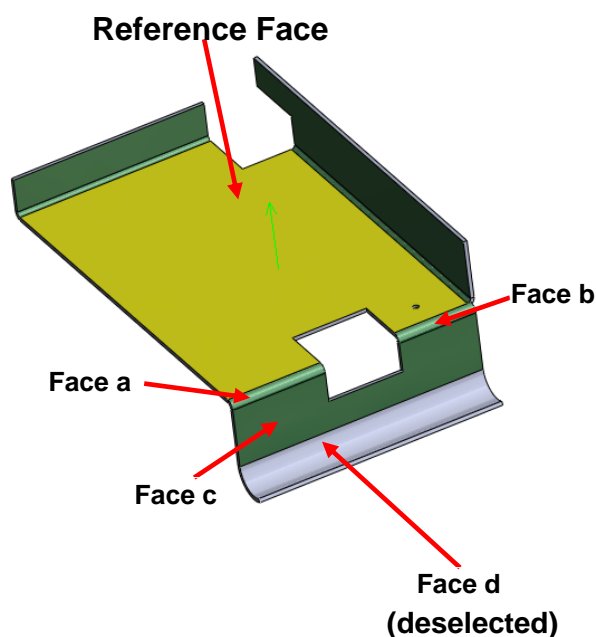



Illustration 2:

- i. On the native part, click on **Face c** in order to deselect it.
- ii. Observe that in addition to **Face c**, the **Face d** (which is adjacent to **Face c**) is also deselected. This is because the deselection of **Face c** causes **Face d** to become completely disconnected from the reference face.
- iii. Click on **Face c** again in order to select it. The **Face d** will also be automatically selected.

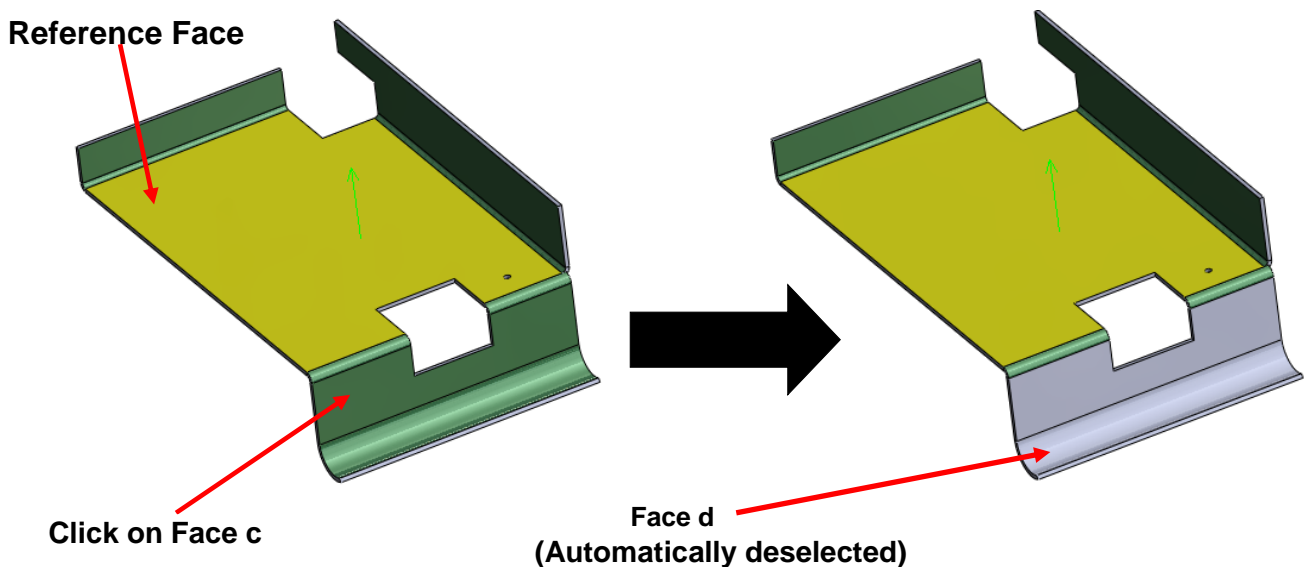

Illustration 3:

- i. On the native part, click on **Face a** (the bent face on the left) in order to deselect it.

Observe that **Face c**, (which is adjacent to **Face a**) is not deselected. This is because **Face c** continues to remain connected to the *Reference face* via **Face b**.

- ii. Now click on **Face b** in order to deselect it.

Observe that, along with **Face b**, **Face c** and **Face d** are also deselected.

Face c is adjacent to both **Face a** and **Face b** and connected to the reference face via these two faces. When both **Face a** and **Face b** are deselected, **Face c** is no longer connected to the *Reference face* and hence is automatically deselected.

Face d is adjacent to **Face c**. When **Face c** is deselected, then **Face d** will no longer be connected to the reference face and is hence deselected.

- iii. Now click on either **Face a** or **Face b** in order to select it once again.

Observe that if you select **Face a**, then **Face b**, **Face c** and **Face d** are also automatically selected. Similarly, if you selected **Face b**, then **Face a**, **Face c** and **Face d** are also selected automatically for unfolding. This is because these adjacent faces are then once again connected to the *Reference face*.

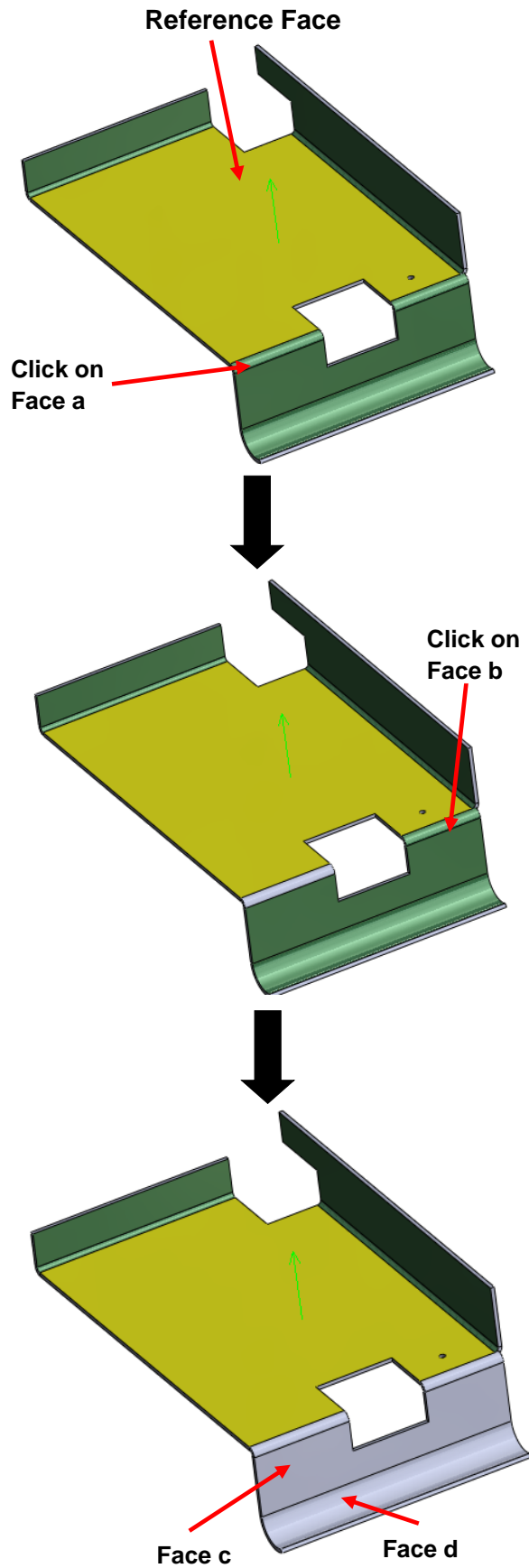



Changing the Reference Face

By default, the reference face is the face with the largest surface area (highlighted in yellow color when the *Interactive Unfold* dialog box is open). All faces tangential to the reference face are selected for unfolding. You can change the face selected as the reference face.

Deselecting the Reference Face

To deselect the reference face of a part, you need to click on the Reference face of the part in the graphics area.

1. In the graphics area, click on the *Reference face* (highlighted in yellow color) of the native part.

Observe that the *Reference face* is deselected and all the faces selected for unfolding are also deselected.

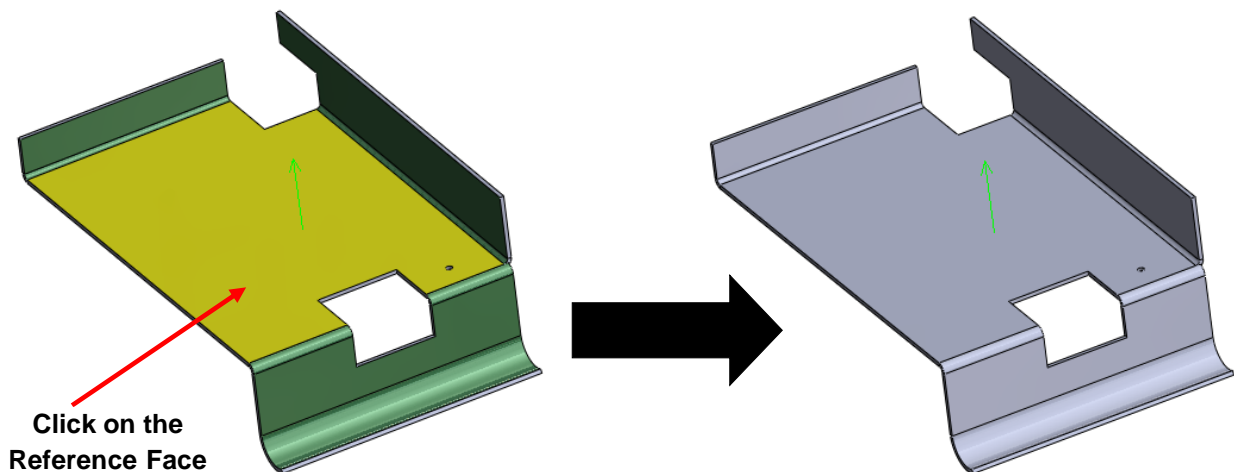

2. After deselecting the Reference face, observe the Interactive Unfold dialog box. Since the native part no longer has a reference face; the Reference Face field for the native part in this dialog box prompts you to select a reference face on the part by displaying the message "Select a Ref Face".

Selecting a Reference Face

When no face is selected as the reference face for unfolding on a part, the 'Interactive Unfold' dialog box prompts you to select a face as the Reference face for the particular part. In order to select a face as the reference face, click on the desired face in the graphics area.

1. In the previous step, the reference face of the native part was deselected. Now, in the graphics area, pick the planar surface on the part as shown in the image on the right. This planar surface will become the reference face (highlighted

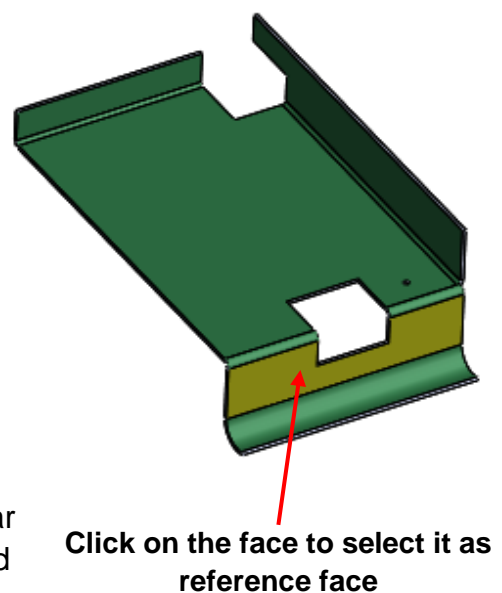



in yellow color) for the native part. All the faces tangential to this new reference face will be highlighted in green thus indicating their selection for unfolding.

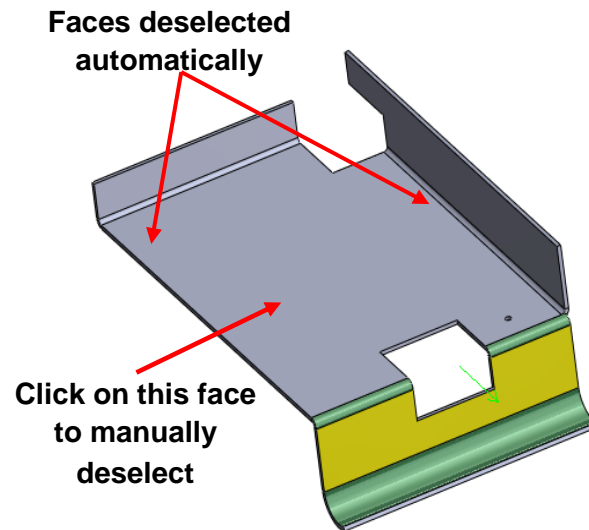

2. Not that auto-selection of tangential faces for unfolding is enabled only when the 'Chain Faces' option is selected in the Interactive Unfold dialog box.
3. As long as the 'Chain Faces' option is checked, the principle of selecting/deselecting the highlighted green faces will apply i.e. If you deselect any highlighted green face, then all the highlighted green faces are adjacent to the deselected face and now disconnected from the reference face will be also be deselected. The vice versa principle applies to selecting faces for unfolding.

For example, click on the highlighted green face with the largest surface area in order to deselect it. Observe that faces tangential to it which are now disconnected from the reference face due to the deselection are also deselected.

4. Once the faces to unfold are selected, you need to click on the OK button on the Interactive Unfold dialog box in order to unfold the part.

The flattened part will be displayed automatically in the graphics area.

STEP 4: Selective Unfolding of Parts when 'Chain Faces' option is disabled

In this section of the tutorial, we will explore how to select reference faces and faces to unfold when the Chain Features option is disabled.

1. If you have followed the instructions given in [Step 3](#) of this tutorial, then close the assembly without saving any changes.
2. Reopen the assembly ([Step 1](#)) and execute the Interactive Unfold command ([Step 2](#)).

Disabling the Chain Faces option

1. In the graphics area, observe that faces are selected for unfolding (highlighted in **green** color) because the *Chain Faces* option is enabled.
2. In the displayed *Interactive Unfold* dialog box, uncheck the *Chain Faces* option.



3. After unchecking the option, close the *Interactive Unfold* dialog box by clicking on the *Cancel* button in the dialog box. This action is necessary for the in order to let the effect of the disabled *Chain Features* option to take place.
4. Open the *Interactive Unfold* dialog box again by executing the *Interactive Unfold* command on the NESTINGWorks menu or NESTINGWorks Ribbon bar.
5. In the graphics area, observe that only reference face (in **yellow** color) will be selected for both the native and imported parts. The face with the largest surface area is selected as the reference face by default. You need to manually select the faces for unfolding.

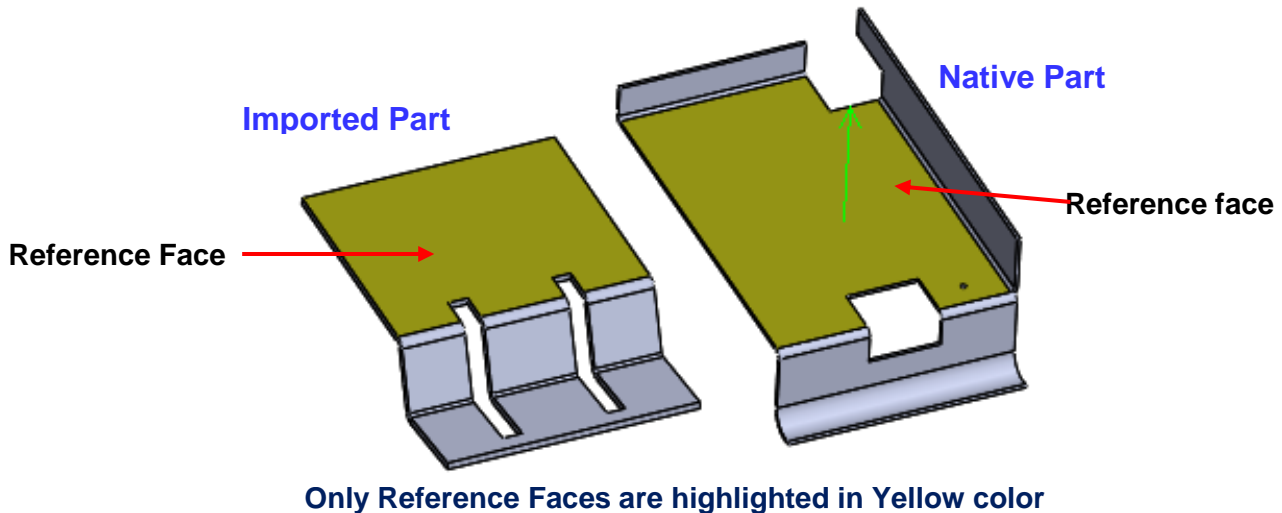

Selecting faces to unfold when Chain Faces option is disabled

To select a face for unfolding, the face should be either adjacent to the reference face or connected to the reference face via an already selected face. A face selected for unfolding is highlighted in green color in the graphics area.

Example:

- i. In the graphics area, on the native part, click on the bent face of the native part as shown in the image on the right. This face then becomes highlighted in green.

Observe that since this face is adjacent to the reference, it is selected for unfolding.

- ii. Now click on the face which is tangential and adjacent to the newly selected face as shown in the image on the right.

Observe that this face too is selected for unfolding though it is not adjacent to the reference face. This face is selected as a face to be unfolded because it is connected to the reference face via the previously selected face.

You can thus select all the desired faces for unfolding one by one by clicking on faces adjacent to the reference face or an already selected face.

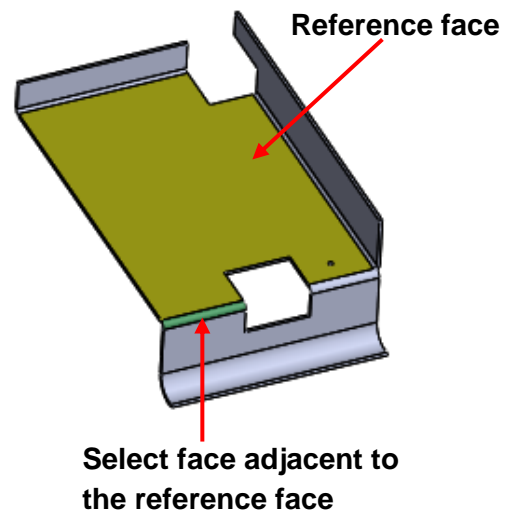

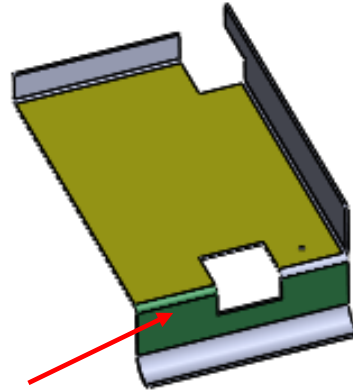

Click on this face
to manually
select the face

- iii. Now deselect the bent face selected for unfolding by clicking on that face. Observe that the face tangential to it (which was also selected for unfolding) has now become a reference face. This is indicated by the change in color from green to yellow.

The face changes to a reference face because the face connecting it to the original reference face is no longer selected.

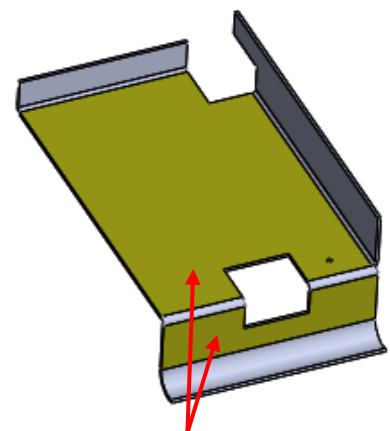

Two Reference

Changing Reference face when Chain Faces option is disabled

To select a face as reference face when the *Chain Faces* option is disabled:

- The face should be planar in nature. Curved faces cannot be selected as a reference faces.
- If no face is selected as a reference face on the part, then any planar face can be selected as the Reference face.
- If one or more faces are already selected as reference faces, then any planar face which is neither adjacent to any of the reference faces nor connected to them via a selected face can be selected as a reference face.

A face selected as reference face will be highlighted in **yellow color** in the graphics area.

Illustration:

- i. In the graphics area, deselect any faces that you may have already selected for unfolding by clicking on the face. If any face other than the face with the largest surface area is also selected as a reference face, then deselect that face by clicking on it.



- ii. When only the face with the largest surface area remains selected as the reference face, then click on the curved face. This curved face is neither adjacent to the reference face nor connected to it via a selected face.

Observe that you cannot select the curved face as a reference face. This is because only planar surfaces can be selected as reference faces.

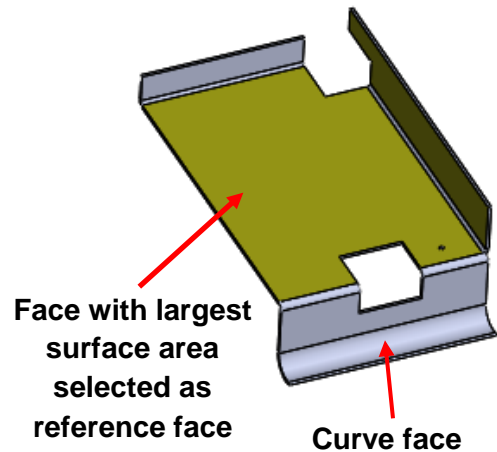

- iii. Now click on the planar face adjacent to the curved face. This face gets selected as a reference face since it fulfills all the conditions for selection of a reference face. It is planar in nature, and neither adjacent to the other reference face nor connected to it via a selected face.

- iv. Now click on any one of the bent faces in order to connect the first and second reference face.

Observe that second reference face that was selected in the previous step now becomes a selected face (indicated by the change in color of the face from yellow to green). This is because the moment the bent face is selected, a face chain is formed and the second reference becomes connected to the original reference face via the bent face.

- v. Now click on the original reference face (the face with the largest surface area) in order to deselect it. Observe that the planar face highlighted in green now once again becomes the reference face.

This is because whenever you deselect a reference connected to other face chains, then the tangentially connected planar face will be selected as a new reference face (selection indicated by change in color of the face from green to yellow).

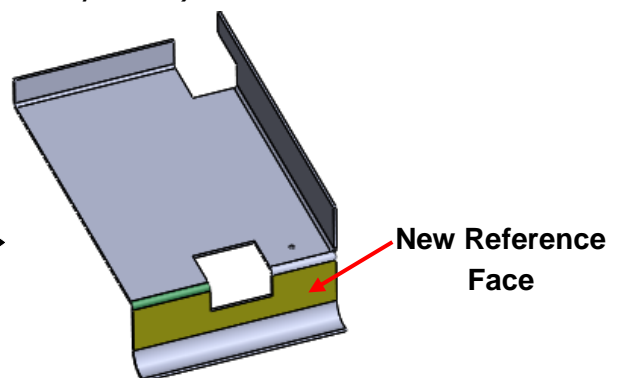
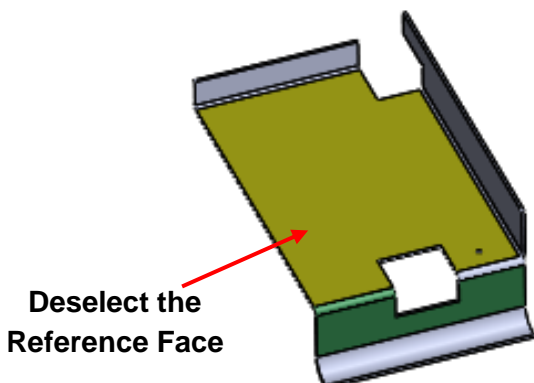
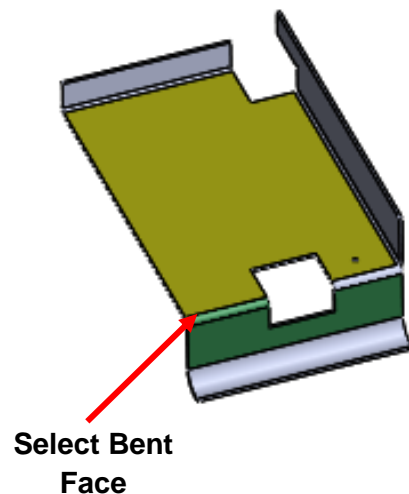



Now click on the deselected reference face (face with largest surface area) once again in order to select it.

Observe that this now selected as a selected face for unfold since it is connected to the current reference face via another selected face.

- vi. Now click on the all the remaining faces in order to select them for unfolding. As you select each face, they will be highlighted in green color thus indicating their selection.
- vii. Now once again click on the central planar surface (face with the largest area) in order to deselect it.

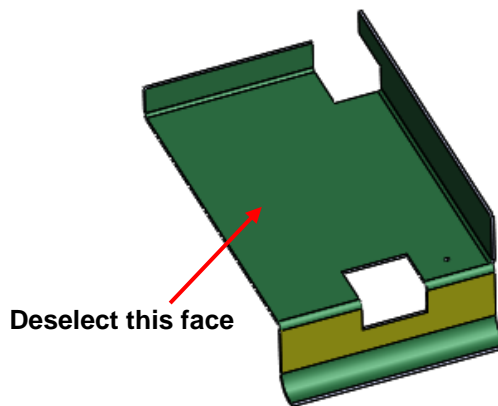
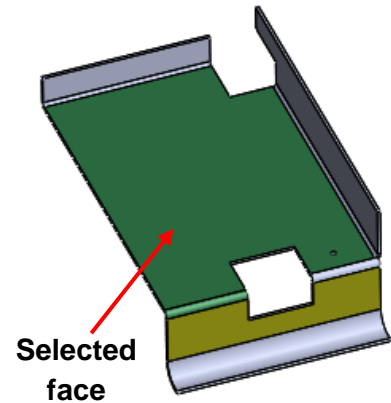

Observe that four faces (two bent faces and two planar faces) are now no longer connected to the reference face due to the deselection of this face. These disconnected faces will now form separate face chains. In each face chain, the planar surface will become the reference face.

As seen in the image on the right, three face chains will be formed with each containing a reference face.

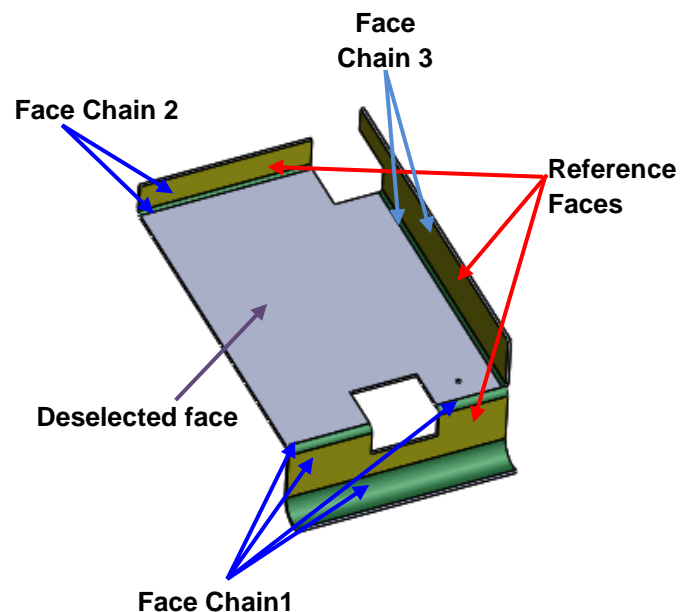

Note: In the newly formed face chain, if there is no planar surface available then such chains will be rejected from the unfolding process automatically.



- viii. Click the OK button of Interactive Unfold dialog box to unfold the parts. Before unfolding, NESTINGWorks will check the parts to be unfolded for the number of disconnected face chains. If a part selected for unfolding retains more than one disconnected face chain, then an error message will be displayed prompting you to remove unwanted face chains. The parts won't be unfolded and the Interactive Unfold dialog box remains open.

To proceed with nesting, you need to ensure that only one face chain is selected on the each part to be unfolded.

Note: On non-faulty parts, the Reference face and the selected faces form a single face chain. NESTINGWorks can only unfold a single face chain when an Unfold command is executed. Multiple face chains cannot be unfolded.

- ix. In the graphics area, click on the central face (face with the largest surface area) in order to select it. Selecting this face for unfolding connects all the face chains.
- x. Click the OK button of Interactive Unfold dialog box to unfold the parts.
- xi. Observe that unfolding is successful for both the imported part as well as the native part.
- xii. Once unfolded, execute the *Create Nest Job* command to nest these parts.

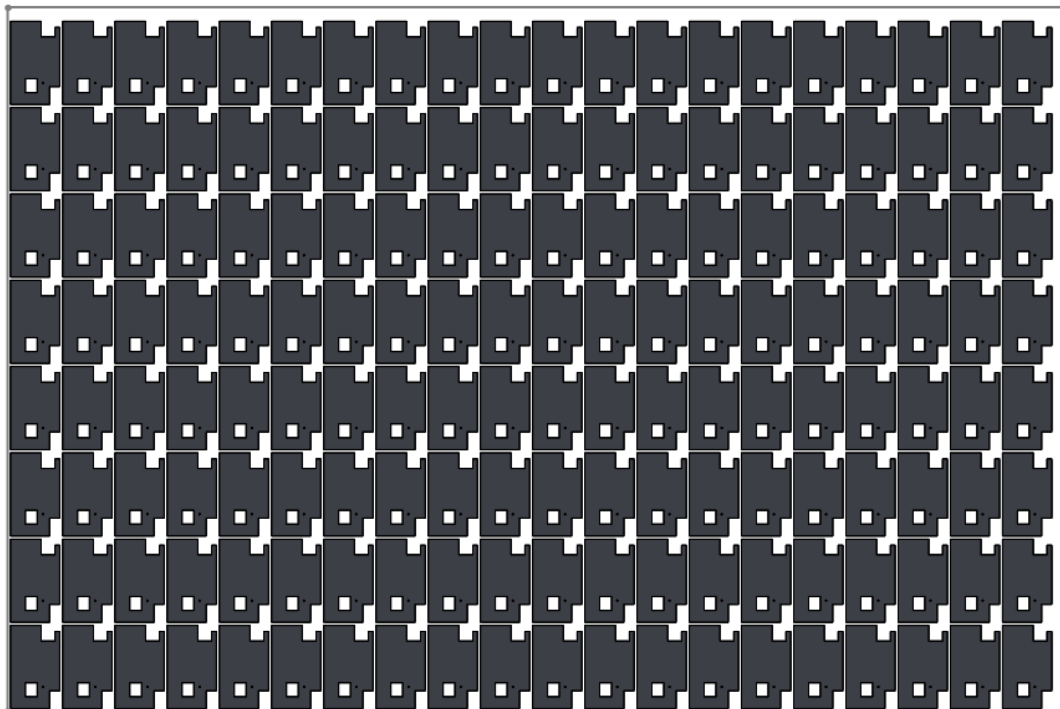
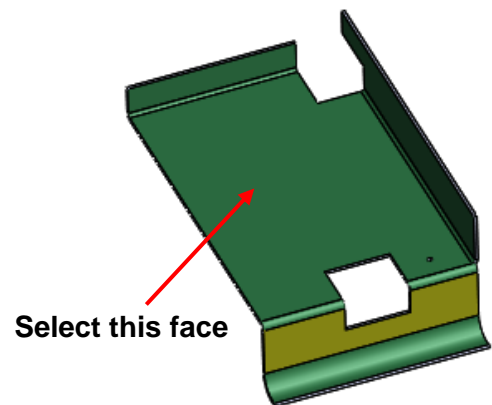

Sample Nesting Layout for native part after unfolding



TUTORIAL 11 – THE STAMP FEATURE UNFOLD

OPTION

Introduction

If a sheet metal part to be nested contains stamp features, an option is provided within NESTINGWorks to control the display of these stamp features after the part is unfolded using one of the unfold commands.

The setting to control the behavior of the stamp features display can be assigned only from the **DefaultValues.ini** file explained in **NESTINGWorks Configuration Files and Associated Settings Guide**. It cannot be set from the 'Create Nesting Job' dialog box.

Topic covered in this Tutorial:

In this tutorial, you will explore how the settings in the *DefaultValues.ini* file affect the behavior of the stamp features present on sheet metal part when the sheet metal part is unfolded.

Assigning Stamp Feature Unfold Option settings in DefaultValues.ini

There are three available settings to control the behavior of the stamp features before nesting the sheet metal part. These settings are controlled from the *DefaultValues.ini* file.

1. Open the file named *DefaultValues.ini* located in the NESTINGWorks Installation folder. (*C:\ProgramData\NESTINGWorksData\NESTINGWorks 201Xx64\Config*)
2. In the [Unfold_Options] section, observe the flag named '*StampFeatureUnfoldingOption*'. This is the flag used to control the behavior of stamp features after the part is unfolded. Following are the settings:
 - i. **0**: Assigning the value '0' ensures that the stamp feature is **retained** after the part is unfolded. (This is the default setting at the time of installation.)
 - ii. **1**: When the value '1' is assigned to this flag, the stamp feature is **patched** with a flat planar surface after the part is unfolded.
 - iii. **2**: When the value '2' is assigned to this flag, the stamp feature is **ignored** after the part is unfolded. The area covered by the stamp feature is replaced with a hole.
3. Once you make any changes to the settings in the *Defaultvalues.ini* file, save the changes and close the file.



Stamp Feature Unfold Option settings for Native parts & Imported Parts

After a sheet metal part with stamp feature(s) is unfolded, the resultant display of the stamp feature based on settings in the *DefaultValues.ini* file (explained in [NESTINGWorks Configuration and Associated Settings Guide](#)) depends on whether the unfolded part is a native sheet metal part or imported sheet metal part. In the case of native parts, it also depends on the type of command used to unfold the part. Given below is table indicating the relation between the various unfold commands and the applicability of the Stamp Feature Unfold Option for native parts and imported parts.

		Type of Part	
		Native Part	Imported Part
Type of Unfold Command	'Intelligent Unfold' command	This command is not applicable to native parts.	Stamp Feature Unfold Option settings in <i>DefaultValues.ini</i> file applied when part is unfolded using this command.
	'Unfold All Parts' command	Stamp Feature Unfold Option settings in <i>DefaultValues.ini</i> file applied when part is unfolded using this command.	
	'Interactive Unfold' command	If this command is executed directly without using any other unfold command, then the stamp features will be always retained irrespective of the settings in the <i>DefaultValues.ini</i> file.	
	'Create Nest Job' command		

This tutorial is divided into two sections:

Part 1: [Stamp Feature Unfold Options for Native Sheet Metal Parts](#)

Part 2: [Stamp Feature Unfold Options for Imported Sheet Metal Parts](#)

Part 1: Stamp Feature Unfold Options for Native Sheet Metal Parts

STEP 1: Open the Part

1. [Launch NESTINGWorks as an Add-In](#) in the SOLIDWORKS environment.
2. Open the part file **Tutorial_11a_native.SLDPRT** located in the following folder:
C:\ProgramData\NESTINGWorksData\NESTINGWorks201Xx64\Examples\Tutorials\Parts
3. Observe that this is a native part with a stamp feature.

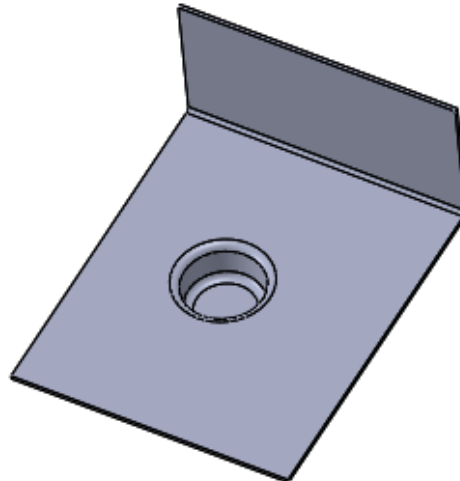

Tutorial_11a_native.SLDPRT

STEP 2: Executing the Unfold Command

For the settings of the Stamp Feature Unfold Option in *DefaultValues.ini* to take effect, you need to first unfold the part. To unfold the part you can use the unfold commands available on the Nesting Ribbon bar as well as the NESTINGWorks menu. Following are the unfold commands you can use to unfold a native part:

1. The 'Unfold All Parts' command

When you execute this command, the Unfold All Parts dialog box will be displayed. Click the *OK* button to unfold the part.

2. The 'Interactive Unfold' command

When you execute this command, the Interactive Unfold dialog box will be displayed. Click the *OK* button to unfold the part.

3. The 'Create Nest Job' command

When you execute this command, the native part will be auto-unfolded before the *Create Nesting Job* dialog box is displayed. (The native sheet metal part will be unfolded only if the flag named ***FlattenSheetMetalPart*** in the ***DefaultValues.ini*** file is set to '1'. This is the default setting)

Note: The 'Intelligent Unfold' command cannot be used to unfold the native parts. This command is applicable only for imported parts.



STEP 3: Retaining the stamp feature

1. Open the *DefaultValues.ini* file and set the *StampFeatureUnfoldingOption* flag to '0'. This setting ensures that the stamp feature is retained after the part unfolding process.
2. When you unfold the native part using any one of the commands mentioned in [Step 2](#), the stamp feature will be retained.

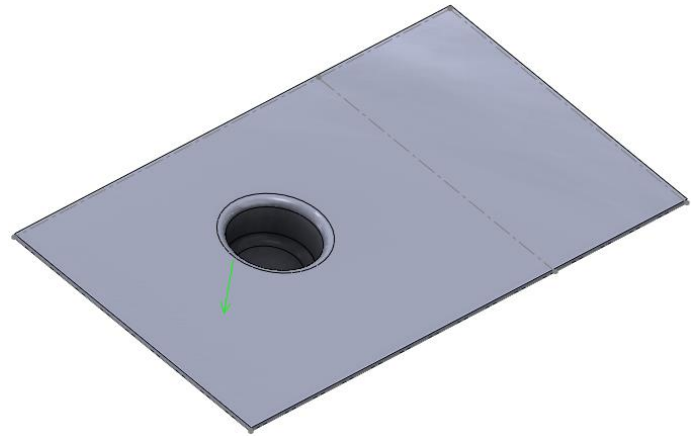

Result of the Retained Stamp Option

STEP 4: Patching the stamp feature

You will now set the stamp feature unfolding option to patch the stamp feature after unfolding.

1. Open the *DefaultValues.ini* file and set the *StampFeatureUnfoldingOption* flag to '1'. This setting ensures that the stamp feature is patched after the part unfolding process.
2. Save the changes and close the *DefaultValues.ini* file.
3. Unfold the part using either the 'Unfold All Parts' or 'Interactive Unfold' command.

Observe that the stamp feature is patched (replaced) with a planar surface after the part is unfolded.

4. Now close the part (without saving the changes) and reopen the part in SOLIDWORKS. Directly execute the 'Create Nest Job' command.

Observe that the stamp feature is retained instead of being patched.

5. This indicates that the setting for the Stamp Feature Unfold Option in the *DefaultValues.ini* was not applied to the part.

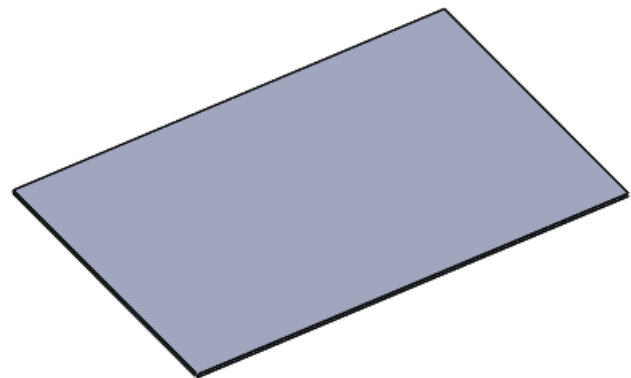

Result of the Patch Stamp Feature option when the 'Unfold All Parts' or 'Interactive Unfold' command is executed

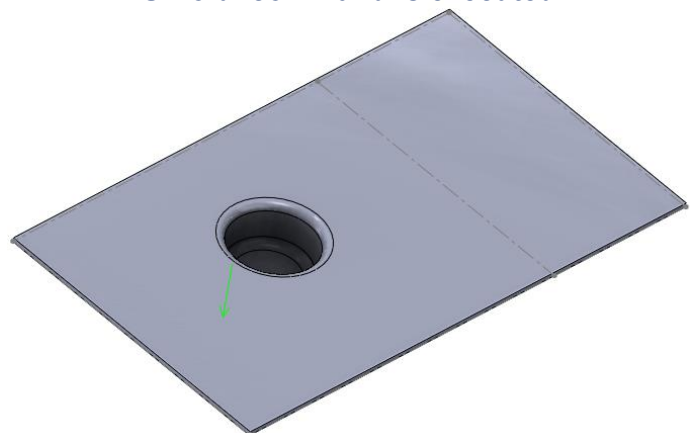

Result of the Patch Stamp Feature option when the 'Create Nest Job' command is executed



Note: If you unfold a native part directly using the 'Create Nest Job' command, then the Stamp features present on the part will always be retained on the part after it is unfolded irrespective of the settings for 'Stamp Feature Unfold Option' in the *DefaultValues.ini* file. This behavior results because NESTINGWorks uses SOLIDWORKS functionality to flatten the native sheet metal parts instead of NESTINGWorks functionalities.

STEP 5: Ignoring the stamp feature

You will now set the stamp feature unfolding option to ignore the stamp feature after unfolding process.

1. Open the *DefaultValues.ini* file and set the *StampFeatureUnfoldingOption* flag to '2'. This setting ensures that the stamp feature is ignored after the unfolding the part.
2. Save the changes and close the *DefaultValues.ini* file.
3. Unfold the part using either the 'Unfold All Parts' or 'Interactive Unfold' command. Observe that the stamp feature is ignored. The area covered by the stamp feature is replaced with a hole.
4. Now close the part (without saving the changes) and reopen the part in SOLIDWORKS. Directly execute the 'Create Nest Job' command. Observe that the stamp feature is retained instead of being ignored.

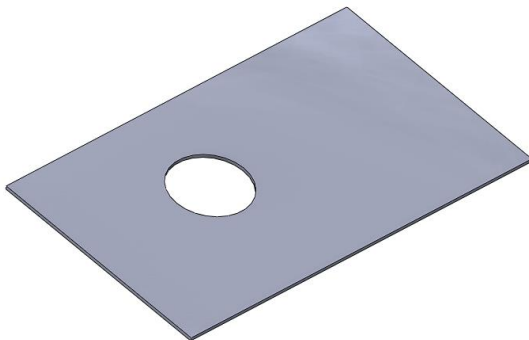

Result of the Ignore Stamp Feature option when the 'Unfold All Parts' or 'Interactive Unfold' command is executed

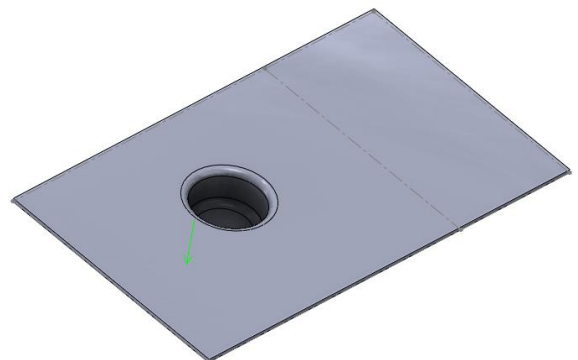

Result of the Ignore Stamp Feature option when the 'Create Nest Job' command is executed

5. This indicates that the setting for the *Stamp Feature Unfold Option* in the *DefaultValues.ini* was not applied to the part.
6. Once the part is unfolded, proceed to nest the part by executing the *Create Nest Job* command.



STEP 6: Behavior in native parts without bends

1. Open the part file **Tutorial_11c_native.SLDPRT** located in the following folder:

C:\ProgramData\NESTINGWorksData\NESTINGWorks 201Xx64\Examples\Tutorials\Parts

Observe that this is an imported part without bends. The part has a stamp feature.

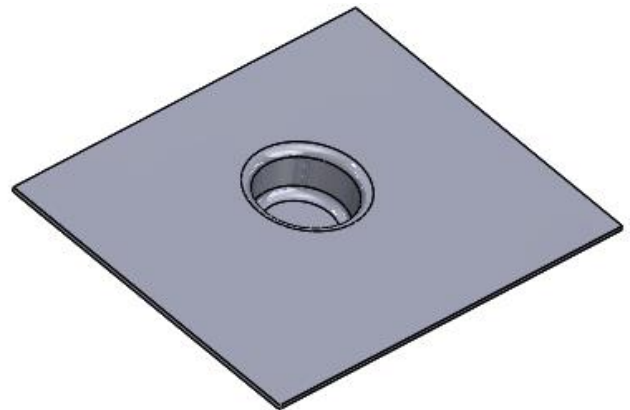

Tutorial_11c_native.SLDPRT

2. Execute [Step 3](#), [Step 4](#) and [Step 5](#) and once again observe that the behavior of the stamp feature changes as per the settings in the *DefaultValues.ini* file only when the 'Unfold All Parts' or the 'Interactive Unfold' command is executed. If the part is unfolded directly using the 'Create Nest job' command, then the setting for Stamp Feature Unfold Option will not take effect and the stamp feature will be retained.

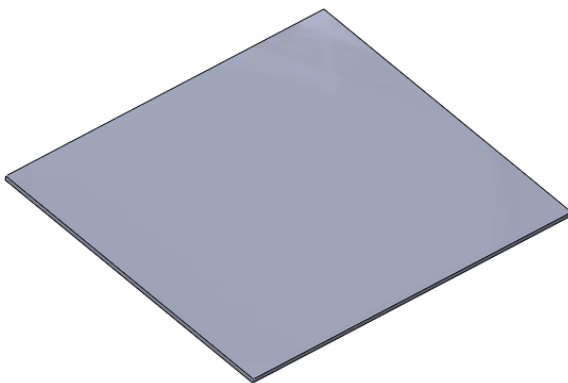

Result of the Patch Stamp Feature option when the 'Unfold All Parts' or 'Interactive Unfold' command is executed

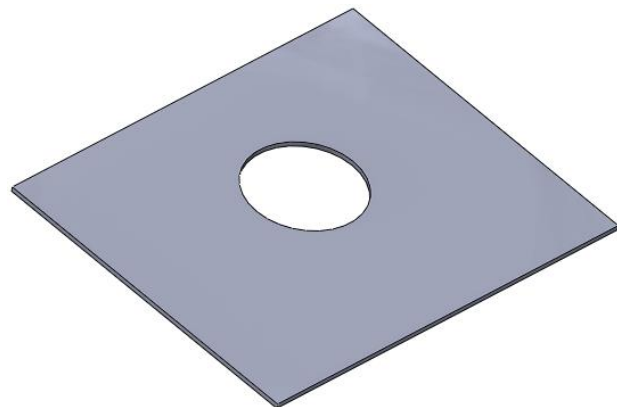

Result of the Ignore Stamp Feature option when the 'Unfold All Parts' or 'Interactive Unfold' command is executed

Note: The settings for the Stamp Feature Unfold Option in the *DefaultValues.ini* file is applicable for a native part only if you first unfold the part using either the 'Unfold All Parts' or the 'Interactive Unfold' command.

For a native part (with or without bends), the stamp feature is always retained on the part if you directly execute the 'Create Nest Job' command without first executing the 'Interactive Unfold' or 'Unfold All Parts' command.



Part 2: Stamp Feature Unfold Option for Imported Sheet Metal Parts

STEP 1: Open the Part

1. [Launch NESTINGWorks as an Add-In](#) in the SOLIDWORKS environment.
2. Open the part file **Tutorial_11b_imported.SLDPRT** located in the following folder:
C:\ProgramData\NESTINGWorksData\NESTINGWorks 201Xx64\Examples\Tutorials\Parts

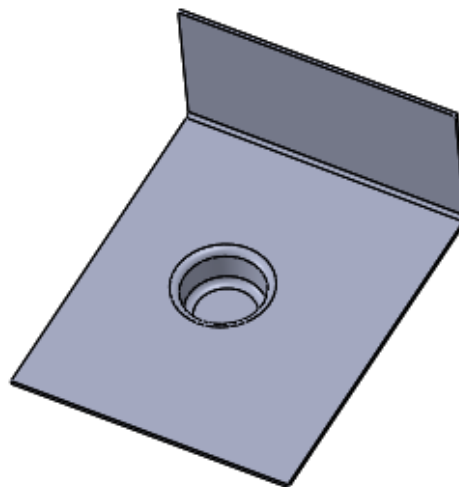

Tutorial_11b_imported.SLDPRT

3. Observe that this is an imported part with bends. The part has a stamp feature.

STEP 2: Executing the Unfold Command

For the settings of the Stamp Feature Unfold Option in *DefaultValues.ini* to take effect, you need to first unfold the part. To unfold an imported part, you can use any one of the following commands available on the NESTINGWorks Ribbon bar as well as the NESTINGWorks menu.

1. **The 'Intelligent Unfold' command** 

When you execute this command, the *Unfold Imported Bodies* dialog box is displayed. Click the *OK* button to unfold the part.

2. **The 'Unfold All Parts' command** 

When you execute this command, the *Unfold All Parts* dialog box is displayed. Click the *OK* button to unfold the part.

3. **The 'Interactive Unfold' command** 

When you execute this command, the *Interactive Unfold* dialog box is displayed. Click the *OK* button to unfold the part.



4. The 'Create Nest Job' command

When you directly execute this command for imported parts/assembly, NESTINGWorks will display a message indicating that the part/assembly contains imported parts and whether you wish to unfold the parts before proceeding with the nesting process. Click *Yes*. The *Unfold All Parts* dialog box will be displayed. Click *OK* button in this dialog box to unfold the parts. If you click the *Cancel* button, then the parts will neither be unfolded nor will the settings for the Stamp Feature Unfold Options be applied to the parts.

STEP 3: Retaining the stamp feature

You will now set the stamp feature unfolding option to retain the stamp feature after unfolding the part.

1. Open the *DefaultValues.ini* file and set the *StampFeatureUnfoldingOption* flag to '0'. This setting ensures that the stamp feature is retained after the part unfolding process.
2. Save the changes and close the *DefaultValues.ini* file.
3. Unfold the part using any one of the commands as listed in [Step 2](#). Observe that the stamp feature is retained after the part is unfolded.

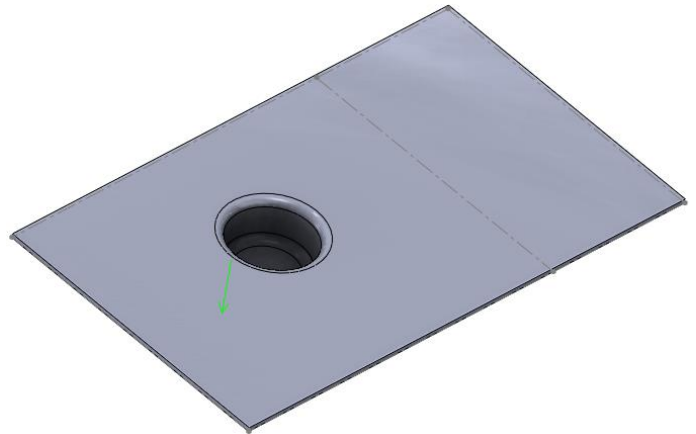

Result of the Retained Stamp Option

STEP 4: Patching the stamp feature

You will now set the Stamp Feature Unfold Option to patch the stamp feature after unfolding the part.

1. Open the *DefaultValues.ini* file and set the *StampFeatureUnfoldingOption* flag to '1'. This setting ensures that the stamp feature is patched after the part is unfolded.
2. Save the changes and close the *DefaultValues.ini* file.
3. Unfold the part using any one of the commands as listed in [Step 2](#).
4. Observe that the stamp feature is patched (replaced) with a planar surface after the part is unfolded.

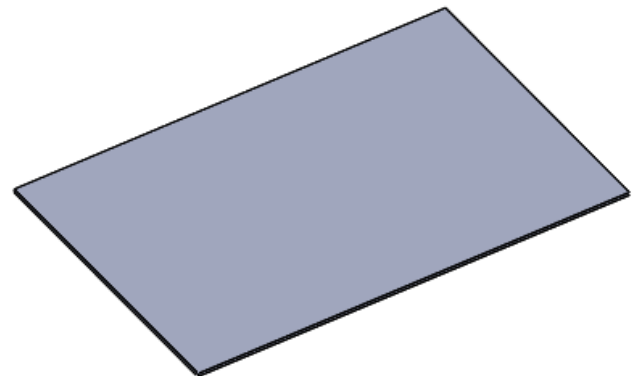

Result of the Patch Stamp Feature option after the part is unfolded



STEP 5: Ignoring the stamp feature

You will now set the Stamp Feature Unfold Option to ignore the stamp feature after unfolding.

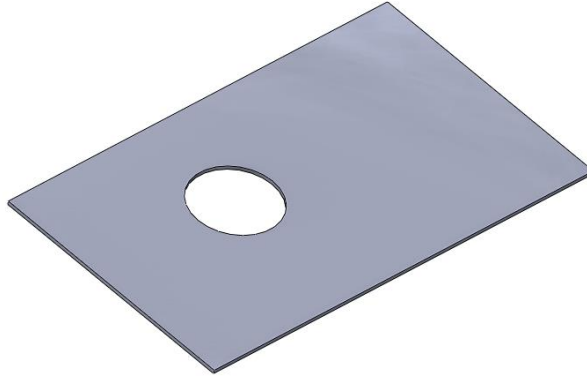

Result of the Ignore Stamp Feature option after the part is unfolded

1. Open the *DefaultValues.ini* file and set the *StampFeatureUnfoldingOption* flag to '2'. This setting ensures that the stamp feature is ignored after the unfolding the part.
2. Save the changes and close the *DefaultValues.ini* file.
3. Unfold the part using any one of the commands listed in [Step 2](#). Observe that the stamp feature is ignored. The area covered by the stamp feature is replaced with a hole.

Note: If you unfold an imported part containing stamp features before nesting the part, then the stamp feature will be retained, patched or ignored based on 'StampFeatureUnfoldOption' flag settings in the *DefaultValues.ini* file.

Once the part is unfolded, proceed to nest the part using the *Create Nesting Job* dialog box.



STEP 6: Behavior in imported parts without bends

1. Open the part file **Tutorial_11d_imported.SLDPRT** located in the following folder:
C:\ProgramData\NESTINGWorksData\NESTINGWorks 201Xx64\Examples\Tutorials\Parts

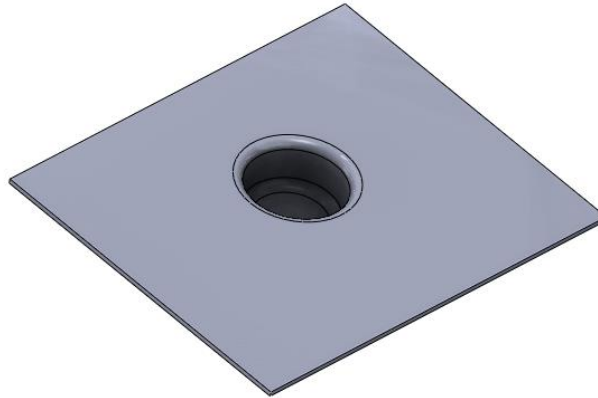

Tutorial_11d_imported.SLDPRT

2. Observe that this is an imported part without bends. The part has a stamp feature.
3. Execute [Step 3](#), [Step 4](#) and [Step 5](#) and observe that the behavior of the stamp feature changes as per the settings in the DefaultValues.ini file.

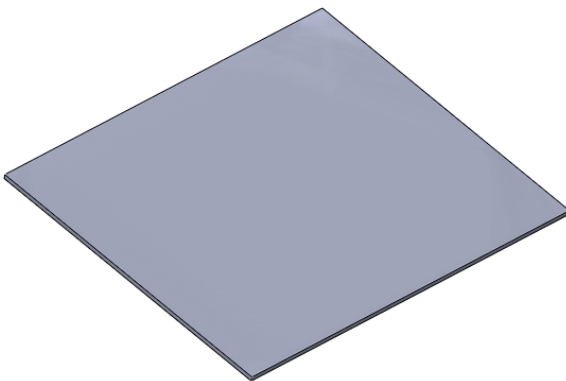

Result of the Patch Stamp Feature option after the imported part is unfolded

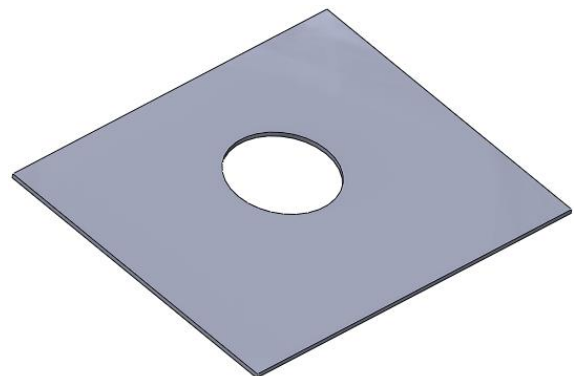

Result of the Ignore Stamp Feature option after the part is unfolded

Note: If you want the settings for the Stamp Feature Unfold Option in the DefaultValues.ini file to be applied to an imported sheet metal part without any bends, then unfold the part using any one of the unfold commands.



TUTORIAL 12 – GENERATING NC CODES FOR NESTED LAYOUTS USING CAMWORKS (I)

How the Nested layouts generated are saved within SOLIDWORKS

Once the Nesting process using the NESTINGWorks application is completed, the nested layout(s) generated will always be saved as a SOLIDWORKS assembly file (*.sldasm). Depending on various factors such as thickness and/or material part of part, number of sheets, grain direction, etc., either one or multiple Nested layouts will be generated.

- If only one nested layout is generated, then it will be saved as a SOLIDWORKS Assembly file comprising of nested parts. The sheet dimensions will be saved as a SOLIDWORKS sketch.
- If multiple nested layouts are generated, then these nested layouts will be saved as a SOLIDWORKS Assembly file comprising of assemblies. Each assembly is a nested layout comprising of nested parts. The sheet dimensions for each sheet will be saved as a SOLIDWORKS sketch.

Once the nested layout(s) are generated, each nested layout assembly (sheet layout containing nested parts) will be listed in the *SOLIDWORKS Configurations Manager*.

Relation between NESTINGWorks and CAMWorks

Both NESTINGWorks and CAMWorks, developed by **Geometric Americas, Inc.** are applications which are fully integrated with the CAD application of SOLIDWORKS/CAMWorks Solids. While NESTINGWorks is a Nesting application, *CAMWorks* is a highly-intelligent CAM application used for generating NC codes. After generating the nested layout with the NESTINGWorks application, the next step would ideally be to generate NC codes for the nested layouts. To generate NC codes, a CAM application needs to be used. Generating NC codes using the CAMWorks application is easier than using other CAM application since:

- Both NESTINGWorks and CAMWorks have been developed by the same entity viz. *Geometric Americas, Inc.*
- Both these applications are fully integrated with SOLIDWORKS.
- Both these applications work with the same file types viz. file types that are compatible with SOLIDWORKS.
- This functionality automatically links the nested layout output of NESTINGWorks as the input for CAMWorks, thereby reducing the number of steps required for generating NC codes. (This functionality is discussed in the next tutorial in detail).

In this tutorial and the [next tutorial](#), you will learn how to generate NC codes for the nested layouts using the CAMWorks application.



Steps to generate NC codes for Nested layouts

To generate NC codes for nested layout assemblies, a number of steps are involved. Following are the steps for generating NC codes for Nested layouts using CAMWorks:

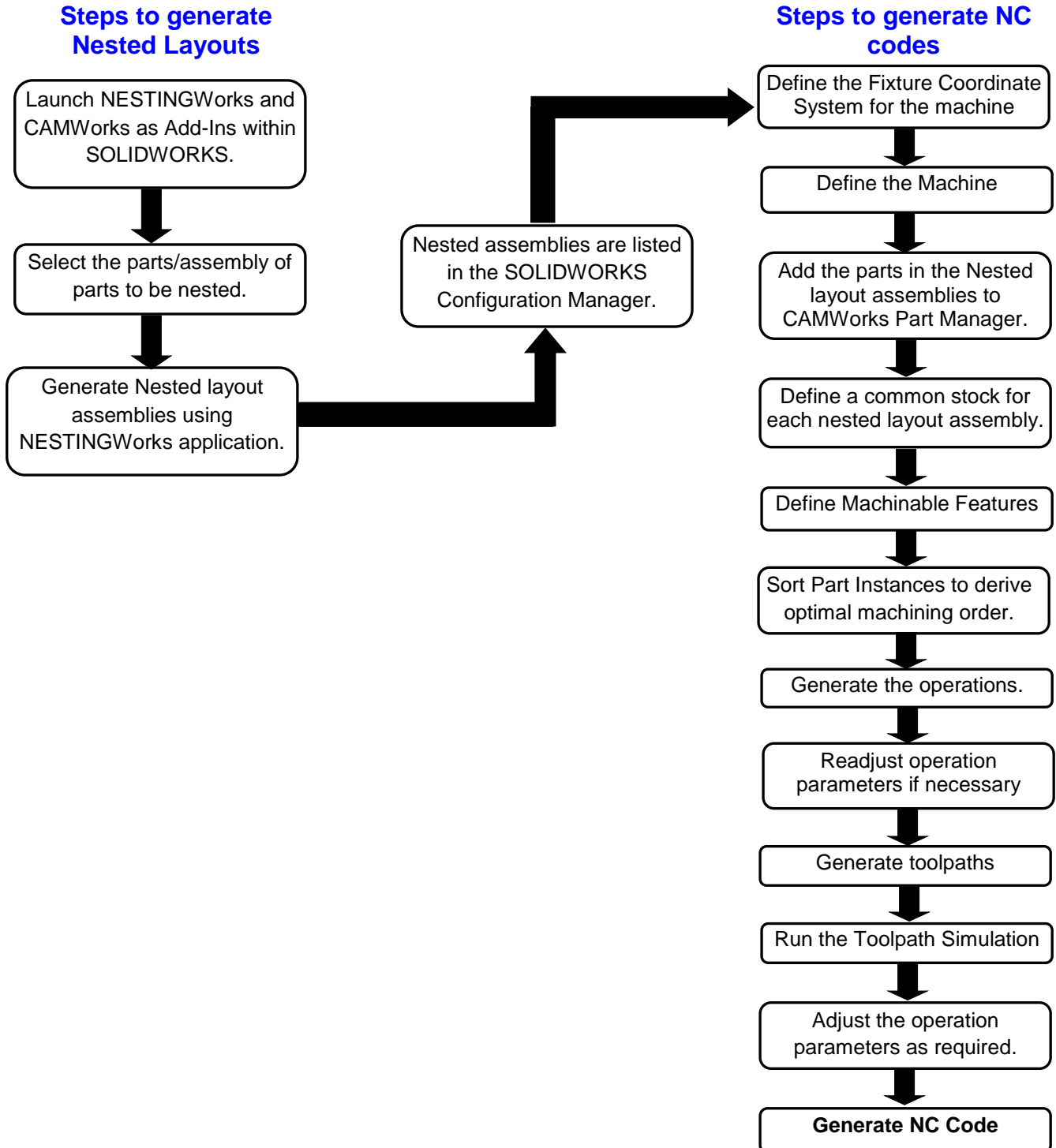

Flowchart illustrating how to generate NC codes for Nested Layout assemblies using CAMWorks



Generating the nested layout assembly

In this tutorial, you will generate NC codes for the nested layout generated in [Tutorial 3](#).

1. Launch NESTINGWorks as an Add-In in the SOLIDWORKS environment.
2. To generate the nested layout, do any one of the following:

- a. **Direct open the nested layout assembly file:**

Open the assembly file **Tutorial_12_Nested_Layout.SLDASM** located in the following folder:

C:\ProgramData\NESTINGWorksData\NESTINGWorks 201Xx64\Examples\
\Tutorials\Assemblies/Tutorial_12

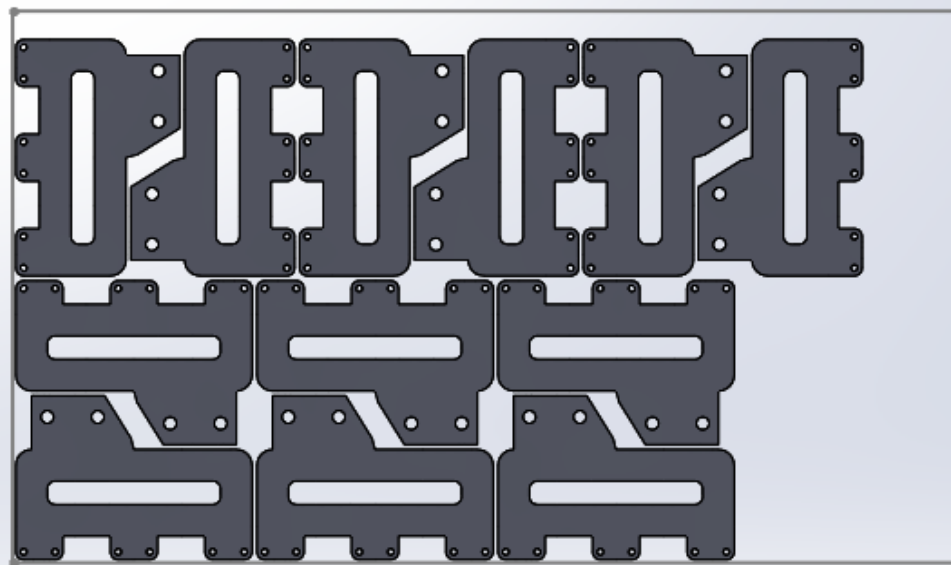

Nested Layout

- b. **Generate the nested layout assembly:**

- i. Open the part file **Tutorial_3.SLDPRT** located in the following folder:
C:\ProgramData\NESTINGWorksData\NESTINGWorks 201Xx64\Examples\
Tutorials\Parts
 - ii. Follow the steps mentioned in the [Tutorial 3](#) of this document to generate the nested layout. However, while executing the Tutorial 3, minor changes are required in *Step 3* and *Step 4* as follows:
 - Under the *Step 3*: Define the Part Parameters; change the assigned quantity for parts from 125 to **12**.
 - Under the *Step 4*: Defining a 'Custom' size sheet, change the assigned length to **600mm** and a width to **350mm**.
 - Execute all the other steps as it is mentioned in the *Tutorial 3* to generate the nested layout as shown below.
 - iii. The generated nested layout obtained from *Tutorial 3* will be used as the input for CAMWorks.
3. In the SOLIDWORKS left hand side panel, click on the SOLIDWORKS *FeatureManager Design Tree*.



- Observe that a sketch (*Sheet1_CustomSheet1*) representing the dimensions of the Custom sheet (in which the parts are nested) is listed in this tree.

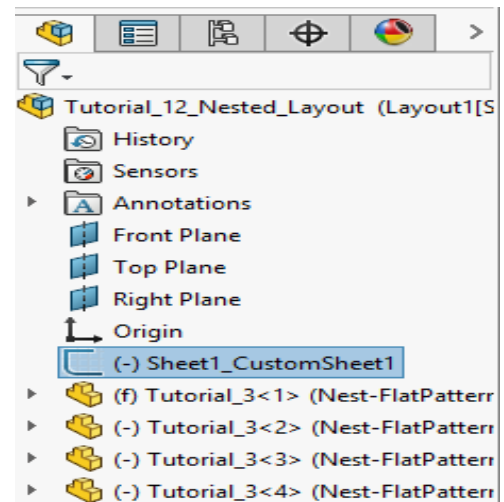

Sketch representing dimensions of Custom sheet

Step 1: Define the Fixture Coordinates

The Fixture Coordinate System defines the "home point" or main zero position on the machine. It defines the default G-code origin, defines the XYZ machining directions and acts as a reference point, if subroutines are used. This coordinate system needs to be defined in the SOLIDWORKS *FeatureManager Design Tree*.

Steps to set the Fixture Coordinates System

- If necessary, rotate and zoom the nested layout assembly in the graphics area to clearly view the position where you desire to assign the coordinate system.
- Click the *Insert* menu on the SOLIDWORKS menu bar.
- From the dropdown menu, select *Reference Geometry* and then select the *Coordinate System* from the cascading context menu.

The *Coordinate System* dialog box is displayed.

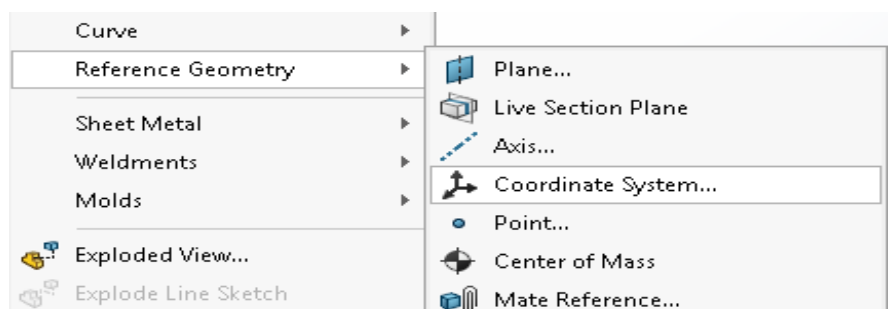

Selecting 'Coordinate System' from cascading menu

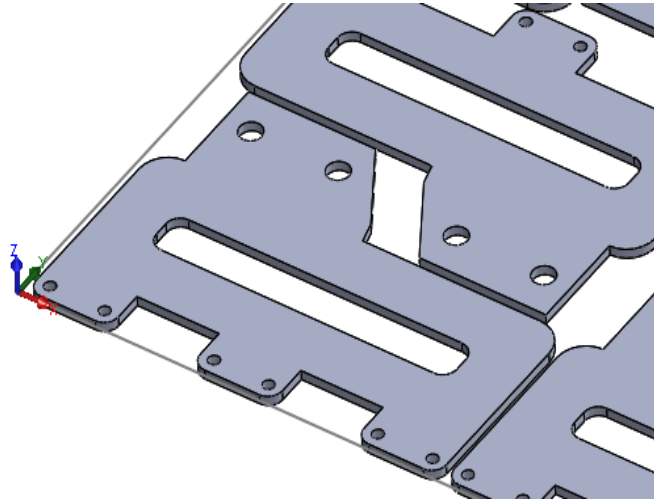

- In the graphics area, click on the *Coordinate System origin*.
- This action will display the selected coordinate system origin in the field of *Selection* group box.
- The *XYZ machining direction* should be same as displayed in the image on the right. If necessary, click on the *Reverse Axis Direction* button to obtain the correct machining direction.
-  Click the *OK* button to save the changes and close the dialog box.
- The defined coordinated system is listed under the *FeatureManager Design tree*.



XYZ machining direction

Step 2: Define the Machine

Before you machine the Nested layout assembly, you need to define the Machine that will be used to machine the assembly.

1. In the SOLIDWORKS left hand side panel, click on the  *CAMWorks Feature Tree* tab. (Note that this tab will be visible only if CAMWorks is loaded as an Add-In within SOLIDWORKS).
2. When the CAMWorks Feature tree is displayed, it initially lists *Configurations*, *Machine*, *Part Manager* and *Recycle Bin* items.
3. Double-click on the  *Machine* item (*Machine [Mill - metric]* in this case) to open the *Machine* dialog box.

The Machine tab of the Machine dialog box is displayed. This tab allows you to select the machine that the assembly will be machined on. By default, either the *Mill - metric* or *Mill - inch* will be already selected.



If you wish to select any other Mill machine or a user-defined Machine definition, then highlight it in the Available Machines list and click the Select button.

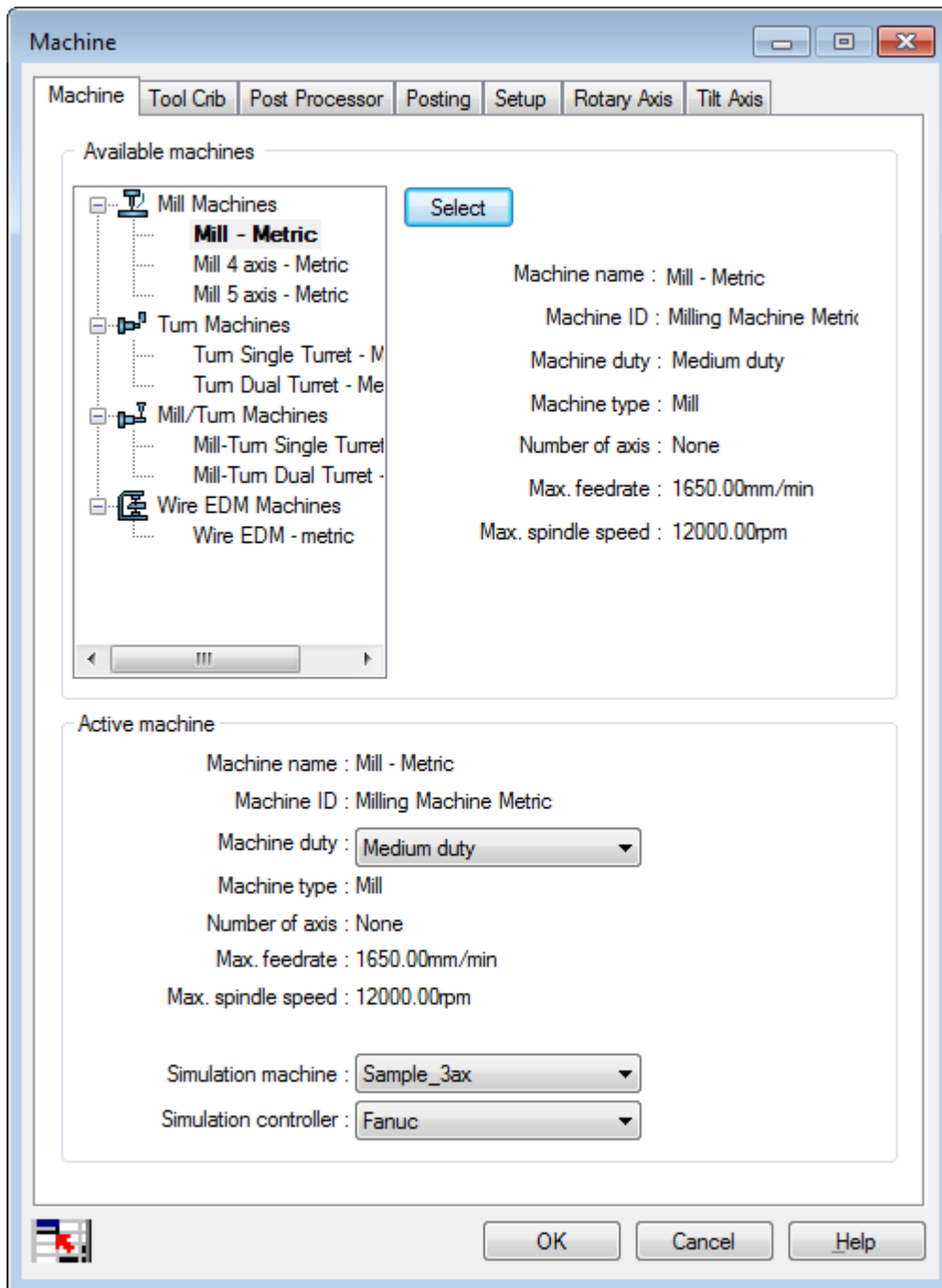

Machine Tab

4. Click on the *Tool Crib* tab, ensure that *Tool Crib 1(metric)* is selected.



To select an alternative tool crib, select the desired tool crib In the Available tool cribs list box and click on the Select button.

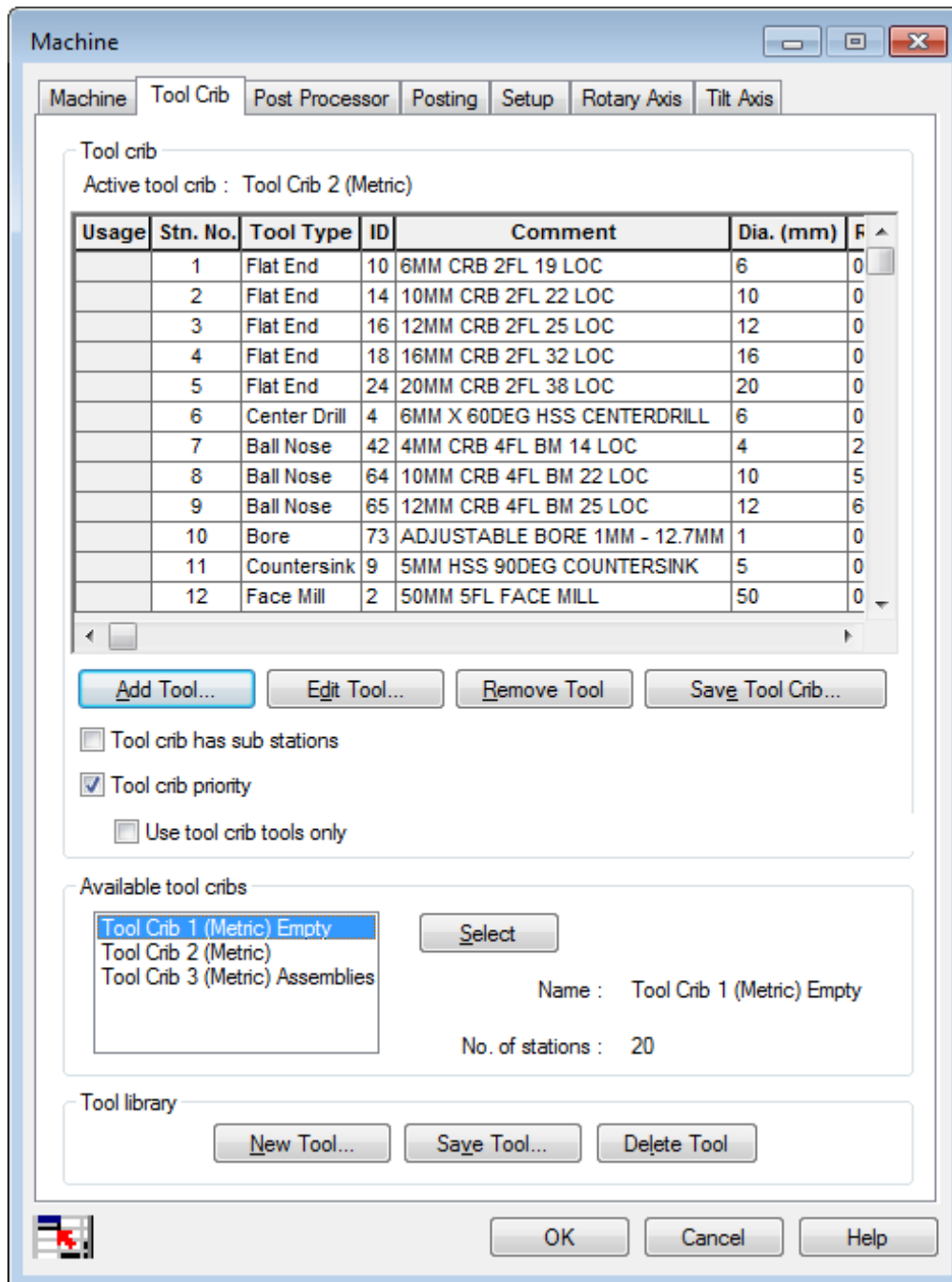

Tool Crib Tab

5. Click on the *Post Processor* tab. This tab allows you to select a post processor for generating NC codes or for generating enhanced CL files that can be used by external third party post processing programs.

By default, the sample post processor *M3AXIS-TUTORIAL* is selected. For this tutorial, this default post processor will be used.



If you wish to use another post processor or a customized post processor provided to you by your CAMWorks Reseller, then highlight the desired post processor in the Available list and click the Select button. If the post processor is not listed, then click on the Browse button to navigate to the folder where the post processor file is located.

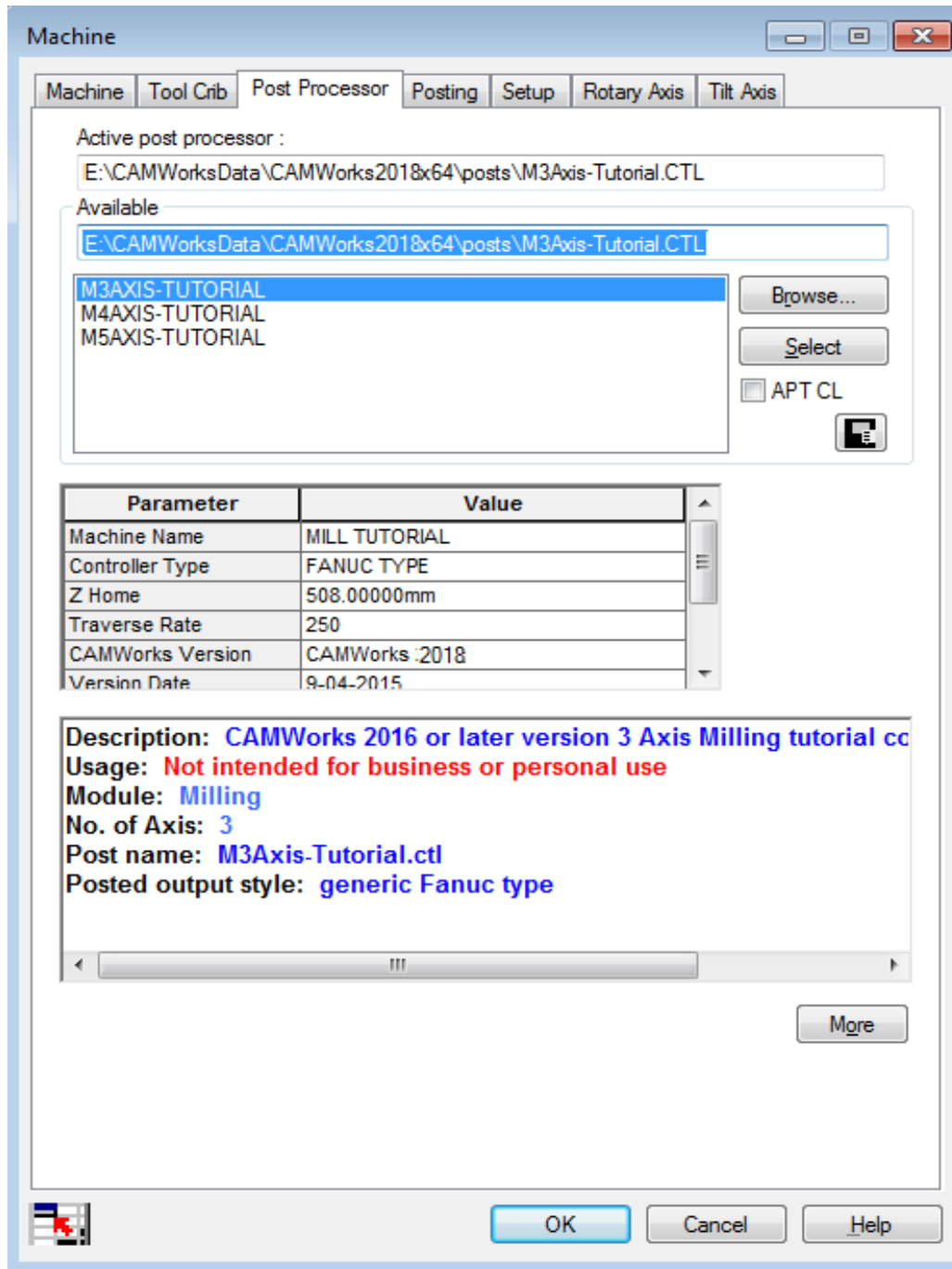

Post Processor Tab of Machine dialog box



6. Click on the *Setup* tab. This tab allows you to set the Fixture Coordinate System for the machine.
 - Since a 2.5 Axis/ 3 Axis Mill Machine will be used to machine the assembly, Indexing will remain set to **None**.
 - In the *CNC comp options* group box, ensure that the Display toolpath at G-code coordinates option is checked.
 - In the *Fixture Coordinate system* group box, Click on the Edit button, Fixture Coordinate System group box is displayed. In the Method group box, select SOLIDWORKS coordinate system from the dropdown list. Highlight **Coordinate System1** in the *Coordinate systems* list box. This action will display the highlighted entity in the *Available Coordinate Systems* list box. Click on the ok  button.
7. Click *OK* to apply the changes and close the *Machine* dialog box.

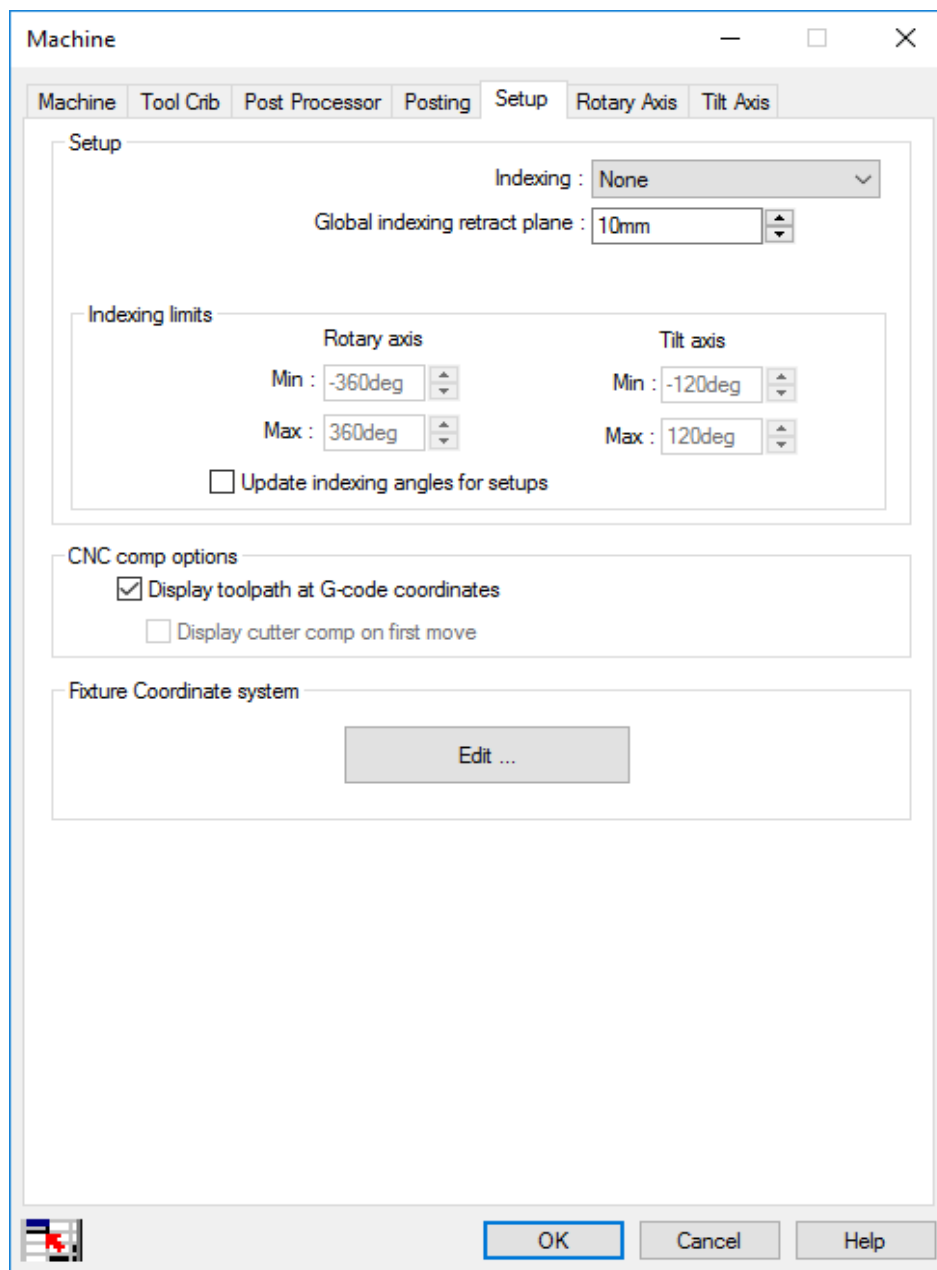

Setup Tab of Machine dialog box



Step 3: Addition of nested Parts to Part Manager

The parts that are to be machined must be identified to CAMWorks by adding them to the *Part Manager* item in the CAMWorks Feature tree.

The Assembly document (*.sldasm) contains different part model documents. In addition to the parts that are going to be machined, the document might contain clamps, fixture of machine components which are included to assist in the layout of the parts and shop documentation. To help CAMWorks identify the components of the assembly file to be machined, the parts that are to be machined must be added to the *Part Manager*.

- When machining multiple instances of the same part, you must add all instances to the Part Manager.
- Feature recognition will only run once for each unique part name. Automatic and interactive features will be referenced automatically at all other part instances.

Following are the steps to add parts to the Part Manager:

1.  Double click *Part Manager* item in the CAMWorks Feature tree.
The *Manage Parts* dialog box is displayed.
2. Select the part in the left corner of the assembly as shown in the image on the right.
For each unique part in the assembly, the first instance that you select is called the **seed part**. When an action is performed on the seed part, the same action will be applied to every other instance of that part in the assembly.
3. Highlight the part in the *Selected Parts* list and click the **Add All Instances** button. The parts are listed in the order they are in the file.

OR

You can also pick the parts individually in the graphics area or in the **SOLIDWORKS FeatureManager Design Tree**.

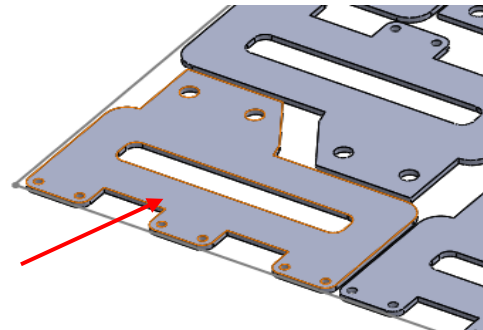

Select the left corner part of Assembly



Part instances can be added at any time.

You can select only one instance of a part (the seed part) to work on first and then add other instances later. Any features, operations and toolpaths that have been generated for the seed part are automatically transferred to instances of the same part when they are added in the Manage Parts dialog box.

4. Later in this tutorial, you use the *Sort Instances* function to change the machining order.
5. Click *OK* to exit the *Manage Parts* dialog box. In the CAMWorks Feature tree, under the *Part Manager* item, observe that:
 - The part name is listed under the **Part Manager** item.
 -  A Feature Manager is created for each unique part. In this tutorial, since only one unique part is machined, only one *Feature Manager* item is created. (It will be used to define the Mill Part Setups and machinable features associated with the seed part.)



-  For each unique part, all the instances are listed under the **Instances** item. You can re-order and/or delete the part instances in the tree.

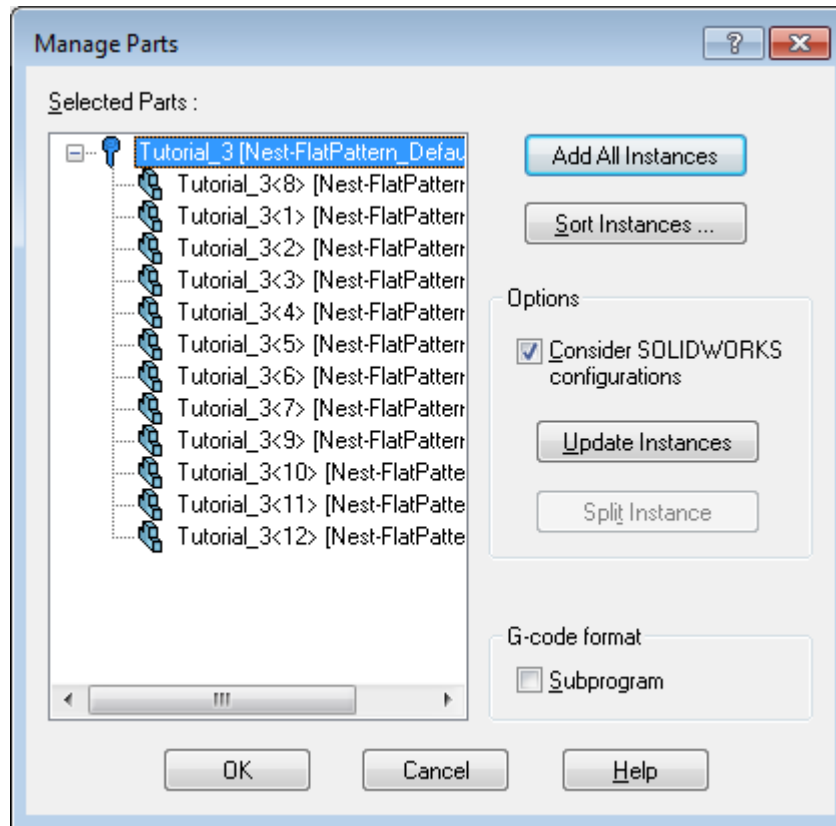

Manage Parts dialog box

Step 4: Define the Stock

When you add parts in the *Manage Parts* dialog box, a default Stock is created for each part based on a 0.00 bounding box offset (cuboid with the minimum required dimensions from which the part can be machined). The *Stock Manager* dialog box allows you to customize the stock associated with the parts.

In this tutorial, all the default individual stocks of type *Bounding Box* created for each part will be replaced a common stock. All the parts will be machined from this common stock.

1.  Double click *Stock Manager* in the CAMWorks Feature tree.

OR

Right click *Stock Manager* item in the CAMWorks Feature tree and select *Edit Definition* on the context menu.

The *Stock Manager* dialog box is displayed. This dialog box allows you to modify the existing default stock or create new stock for single parts or define common stock for multiple parts. Observe that the default stock is *Bounding Box* with zero offsets.



2. Under Stock Type, select **Extruded Sketch**.
3. Pick the rectangular sketch representing the sheet in the graphics area.

OR



In the top left corner of the graphics area, expand the SOLIDWORKS tree (*Tutorial_12_Nested_Layout*) and select the sketch *Sheet1_CustomSheet1*.

This action will select this sketch.

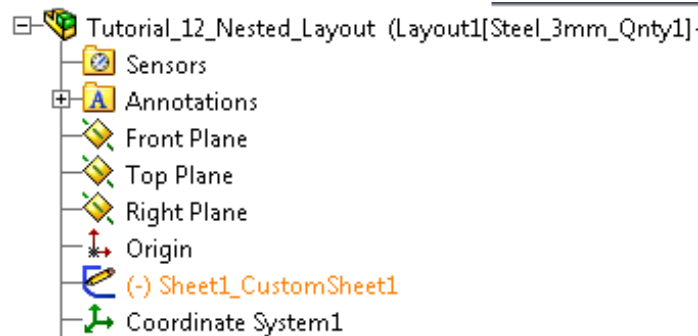

Highlight Sheet1_CustomSheet1 in the tree

4. In the *Depth* field, set the Depth to 3mm.
5. Scroll down the *Stock Manager* dialog box and in the *Create Stock* group box, click the *Common* button.
CAMWorks will display the warning message stating that parts instances already have stock which will then be deleted.

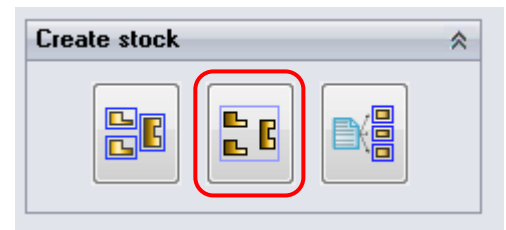

Click 'Common' button

6. Click Yes to delete the individual stocks for the parts and replace them with a common stock.
7. Click *OK* to close the *Stock Manager* dialog box.

Step 5: Defining Machinable Features

The next step is to automatically extract the machinable features using the **Automatic Feature Recognition (AFR)** technology available in CAMWorks. The machinable features extracted all applicable to all instances of the part.

At the Mill Part Setup level, features can be inserted interactively using the *New 2.5 Axis Feature* or *New Multi Surface Feature* or *New Part Perimeter Feature* commands. Such an insertion of features is known as **Interactive Feature Recognition**.

For each unique part, the Machinable Features recognized are added under the *Feature Manager* item of the *CAMWorks Feature Tree*. The features (both automatically recognized or interactively inserted) for the seed part are automatically copied to all other part instances defined in the *Part Manager*.

Extracting Machinable Feature using AFR

1. Click the *Extract Machinable Features* button on the CAMWorks Command Manager.
OR



Right click *CAMWorks NC Manager* in the CAMWorks Feature tree and select *Extract Machinable Features* command on the context menu.

2. The *CAMWorks Message Window* is displayed. This window is displayed automatically to report the progress of the current process. Close this Message Window.

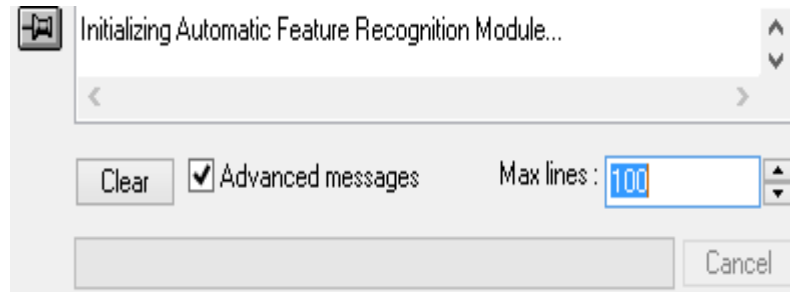

CAMWorks Message Window

3. On execution of the *Extract Machinable Features* command, CAMWorks generates the Mill part Setup and the machinable features. The items are displayed in the CAMWorks Feature tree under *Part Manager>>Feature Manager*.
4. Expand the  *Feature Manager* item in the CAMWorks Feature tree by clicking on the + sign next to it.
5. The *Feature Manager* lists the Mill Part Setup and machinable features that were automatically recognized using AFR.

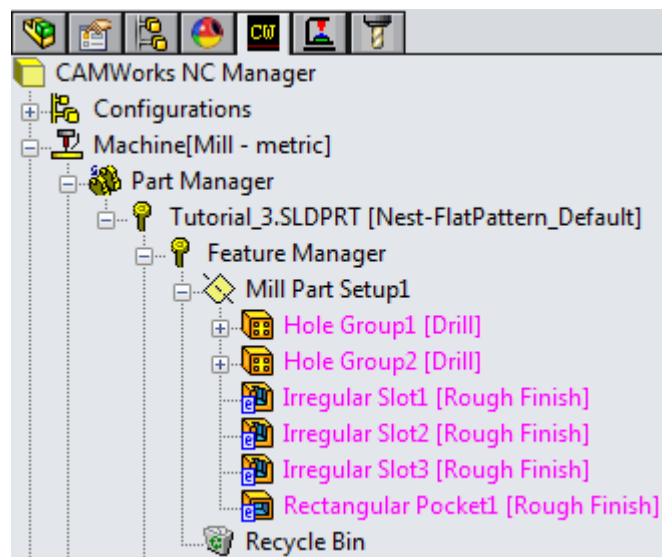

List of Machinable Features recognized using ARF

Interactively Inserting Features

The Part Perimeter feature was not recognized automatically using AFR. Hence, this feature will be inserted interactively.

1.  Right click *Mill Part Setup1* under the *Feature Manager* and select *New Part Perimeter Feature* on the context menu.

The *New Perimeter Feature* dialog box is displayed.



2. Within this dialog box, change the Feature type to *Boss*.
3.  Click *OK* to close the dialog box.

The *Perimeter Boss* feature is added to the list of features under *Mill Part Setup1*.

All features listed under *Mill Part Setup1* are added to the seed part and also to every instance of the part.



When you recognize features by Automatic Feature Recognition (AFR) or Interactive Feature Recognition (IFR), the features listed in the CAMWorks Feature tree will display in Magenta color (by default) till you generate operations for these features. Once a valid operation is generated, the color of the corresponding feature item will change Black color (by default) indicating successful generation of the operation(s).

If operations could not be generated for a feature (because the feature conditions have not been defined in the Technology Database for that particular feature type), then the feature will continue to display in the initial color (Magenta color), thus indicating that they have no operations defined.

You can set these colors on the Display tab in the CAMWorks Options dialog box.

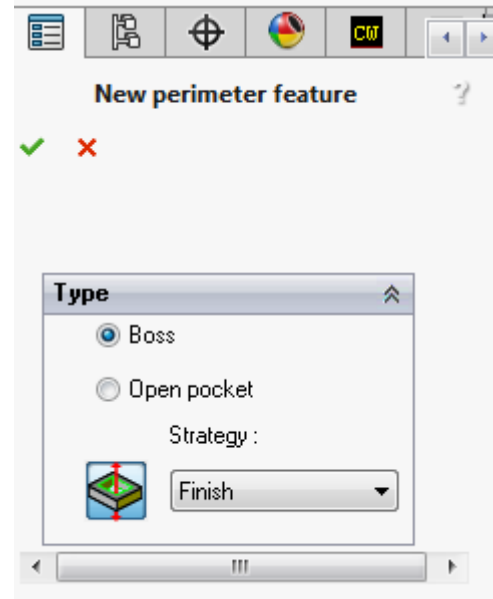

New perimeter Feature dialogue box

Step 6: Sorting Part Instances

When part instances are automatically added or manually added using the *Add All Instances* button, the instances need not necessarily be listed in the best machining order. CAMWorks provides options for sorting part instances to be processed in a more efficient order.

Following are the steps to sort Part Instances:

1. Under *Setup1* in the CAMWorks Feature Tree, expand all the listed feature items by clicking on the  plus sign next to them.

The order in which the part instances are listed under each feature is the machining order for that feature. By default, for all features, the parts are in the order they appear in the *Part Manager*. You can change the order globally for all features or for individual features.

2. In this tutorial, you will set the machining order for all the features globally.
3.  Double click *Part Manager* in the CAMWorks Feature Tree.
4. Click the *Sort Instances* button in the *Manage Parts* dialog box.
5. The *Sort Instances* dialog box is displayed. This dialog box provides automatic or manual options for sorting the part instances for features in the Setup.



The Part Manager instances option automatically sorts part instances for all features in the Setup based on the user-defined order of instances listed in the tree under the Part Manager. To set the order using this option, expand the Part Manager and Instances items, then drag and drop the part instances.

- The **Part Manager instances** option automatically sorts part instances for all features in the Setup based on the user-defined order of instances listed in the tree under the *Part Manager*. To set the order using this option, expand the *Part Manager* and Instances items, then drag and drop the part instances.
- **Grid pattern** automatically sorts part instances for all features in the Setup based on the start corner, processing direction and process order.
- The **Feature instances** option allows you to manually reorder the part instances listed under each feature in the Setup. To set the order using this option, expand a feature in the Setup, then use drag and drop to move the part instances.

You can use one of the automatic methods, then if necessary, select the Feature instances option and make changes to the part order for individual features.

6. Select the *Grid pattern* option.

When you will select the *Grid pattern* option, the order will change for the part instances under every feature in the Setup.

7. Select the following Grid options:

- Start corner= *Bottom left*
- Direction= *Horizontal*
- Pattern= *Zigzag*

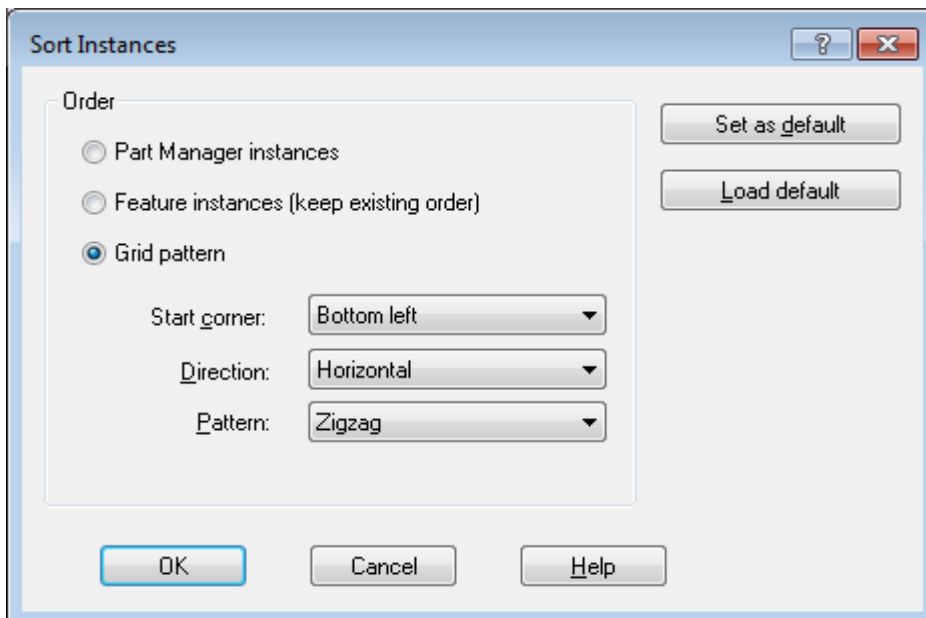

Sort Instances Dialog Box

8. Click OK to close the **Manage Parts** dialog box.



- Click the (+) plus sign next to any feature listed under **Setup1**. Observe any changes in the order of the part instances.

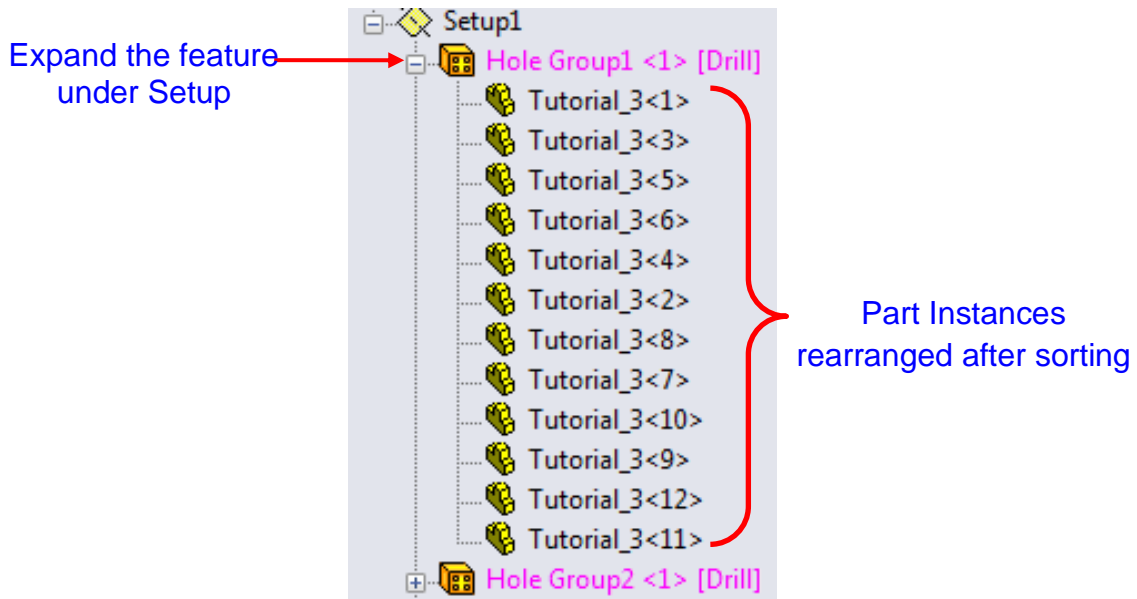

Part Instances rearranged after executing Sort Instances command

Step 7: Generating the Operation Plan

An Operation Plan contains information on how each machinable feature is to be machined and how the NC code will be output. When *Generate Operation Plan* command is executed, operations for each machinable feature are created automatically based on information in the TechDB. The operations generated are listed in the *CAMWorks Operation tree*.

To execute this command:

- Click the *Generate Operation Plan* button on the CAMWorks Command Manager.

OR

Right click the *CAMWorks NC Manager* item of the CAMWorks Feature tree and select *Generate Operation Plan* on the context menu.

- On execution of this command, CAMWorks switches to the CAMWorks Operation tree. All the operations generated are listed under *Setup1* in the CAMWorks Operation tree.

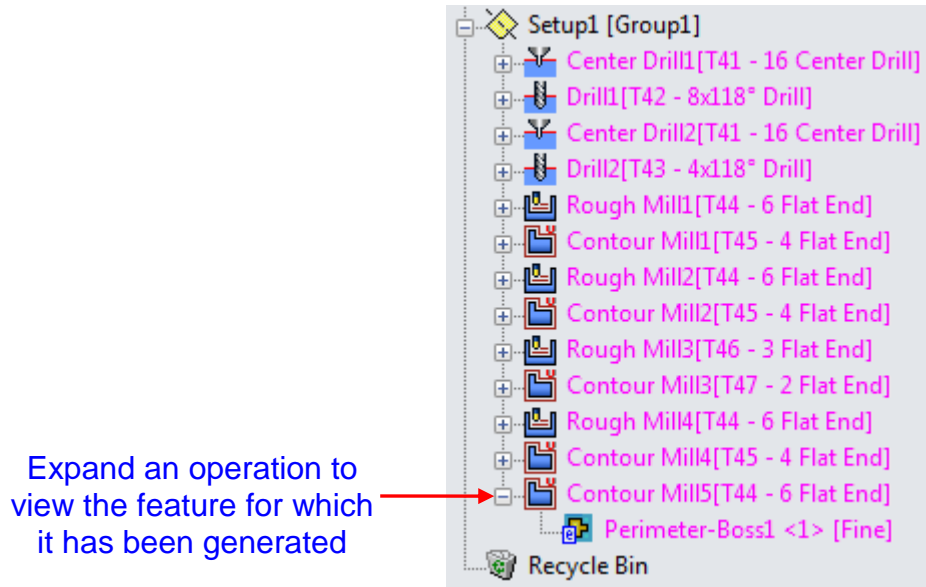

Generated Operations listed in
CAMWorks Operation Tree



When Operations are generated or interactively inserted, they will be displayed in **Magenta color** (by default) in the CAMWorks Operation Tree till you generate toolpaths for these operations. Once the toolpath is generated, the color of the corresponding operation will change to **Black color** (by default) indicating successful generation of the toolpath.

3. Click on the (+) plus sign next to an operation indicates the feature for which the operation has been generated. One or more operations may be generated for each machinable feature. For example, click on the + sign next to *Contour Mill5* operation. This operation has been generated for the *Perimeter Boss* feature.

Step 8: Adjusting Operation Parameters

While generating the nested layout, the **Part-to-part distance** was set to **3 mm** and the **Part-to-sheet distance** was set to **2 mm**.

The **Contour Mill5** operation generated for Perimeter Boss feature is used to machine the perimeter of the part and thereby separate it from the common stock. Since the **Part-to-part distance** is **3 mm** and the **Part-to-sheet distance** is **2 mm**, the **Flat End Mill tool** used for machining the **Contour Mill5** operation should not exceed 2mm in diameter else it might end up gouging the part.

1. In the Operation tree, double click *Contour Mill5* operation.
OR
Right click *Contour Mill5* and select *Edit Definition* on the context menu.
The *Operation Parameters* dialog box is displayed.
2. Click on the *Tool* tab and select the *Mill Tool* Page.

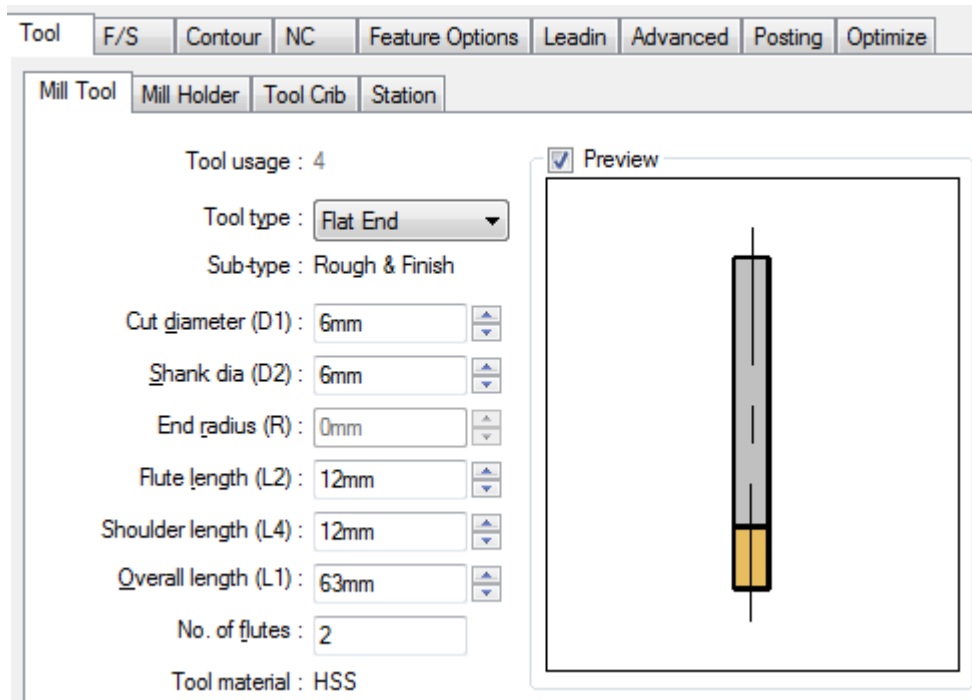

Mill Tool Page under Tool Tab of Operation Parameters dialog box

Observe that the diameter of the tool currently selected for this operation is 6mm. This tool will gouge the part. Hence, another tool needs to be selected for machining this operation.

3. Under the *Tool* tab, click on the *Tool Crib* page.
4. In the displayed tool crib, highlight the 1mm diameter *Flat End* Mill Tool within the list of displayed tools.
5. Click the *Select* button. This action will assign the highlighted tool as the tool to be used for machining this operation.
6. CAMWorks will display a warning message indicating whether you wish to replace the corresponding holder also. Click *Yes* to replace the corresponding holder.

The *Mill Tool* page is now displayed. It displays the parameters of the selected tool.

7. Click *OK* to apply the changes and close the *Operation Parameters* dialog box.

Step 9: Defining G-code Program Zero Location

Toolpaths can be output relative to the Part Setup origin or a global Setup origin. In this tutorial, you will use the Part Setup origin. The Part Setup origin specifies only the toolpath zero point, not the XYZ machining direction. The machining direction is based on the Fixture Coordinate System. When machining multiple instances of the same part, the origin is defined relative to the first (seed) part and referenced for all other instances of the same part.

1.  Double click *Setup1* in the CAMWorks Operation tree.
The *Setup Parameters* dialog box is displayed.
2. On the *Origin* tab, make sure *Part Setup origin* is selected for the Output origin.



Note that when Setup origin is selected, you can specify the origin using several methods.

3. Click on the *Offset* tab.

The order of the parts on this page affects only the assignment of the offsets, not the machining order.

4. In the Sort by group box, select *Grid pattern*.

When you pick this option, the parts in the table are automatically reordered based on the current settings for Start corner, Direction and Pattern.

5. Set the Grid pattern parameters to the same settings you used when sorting part instances for the machining order ([Step 7-Point 6](#)):

- Start corner = *Bottom left* (specifies which part, based on a grid layout, will be assigned the register equal to the Start Value)
- Direction = *Horizontal* (relative to the Start corner part, the Direction defines which part will be assigned the next offset register value)
- Pattern = *Zigzag* (defines the order the offsets are assigned)
- Notice that the part order is updated in the table. You can specify a programmable coordinate offset and assign an offset to each part.

6. Set the Work coordinate offset to *Work Coordinate*. This option will output G54, G55, etc.

7. Set the *Start* value to 54 and the *Increment* to 1.

8. For the *Start* value, specify only the numerical value of the offset and not the G-code prefix.

9. Click the *Assign* button of the Work Coordinate offset group box. The numbers update in the Offset and Sub columns in the table.

10. Click *OK* to close the Setup Parameters dialog box.

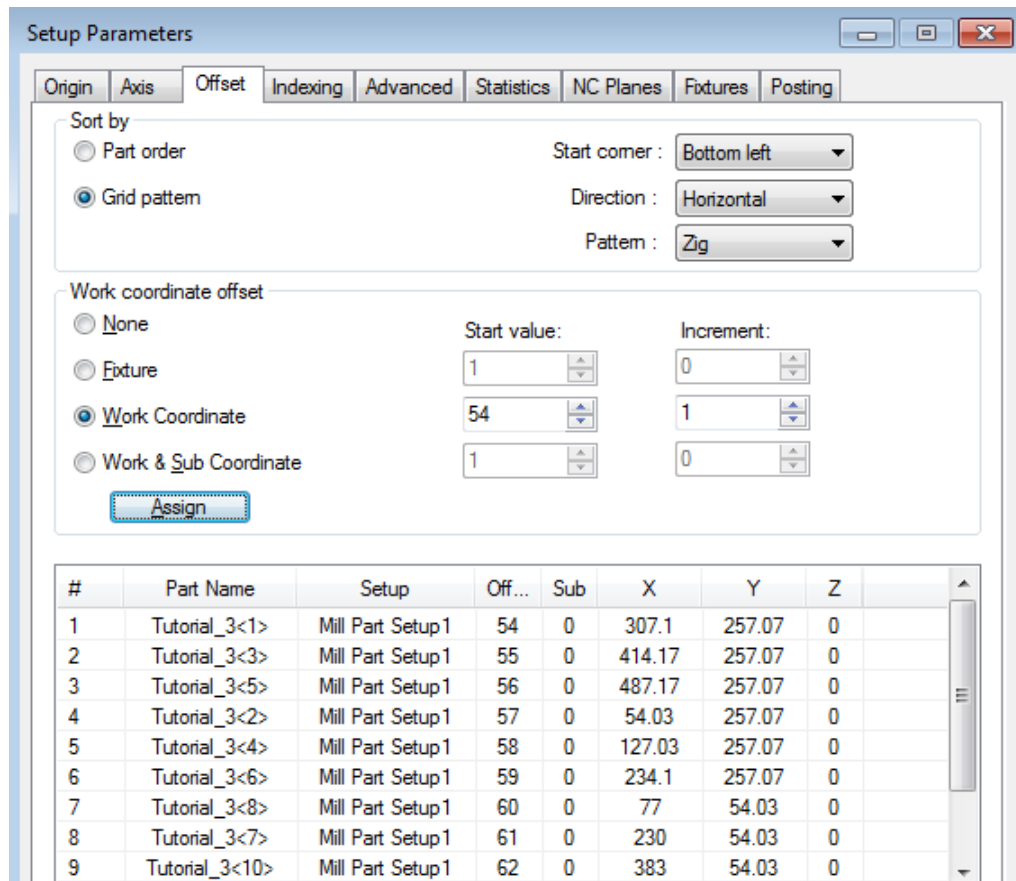

Setup Parameters Dialog Box

Note: Changing the machining order does not automatically change the offset assignments. If you want the offset order to correspond to the machining order, you need to sort the parts and reassign the offsets on the Offset tab.

Step 10: Generating Toolpaths and Sorting Operations

Operations are generated for machinable features and listed in the CAMWorks Operation tree in the same order as the corresponding features in the CAMWorks Feature tree. This sequence is not necessarily the ideal machining sequence. Operations can be sorted in order to reduce machining time.

In this step, all the operations listed in the CAMWorks Operation tree will be sorted in order to create a logical machining sequence.

1. Click the *Generate Toolpath* button on the CAMWorks Command Manager.

OR

Right click *Setup1* in the Operation tree and select *Generate Toolpath* on the context menu.

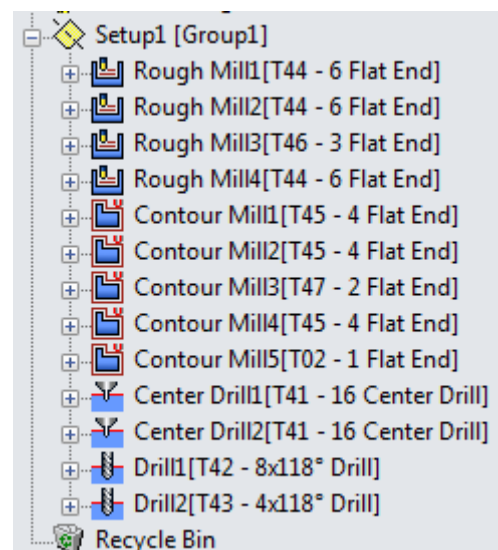

Updated list of operations after executing the Sort Command



- On executing the *Generate Toolpath* command, CAMWorks calculates the toolpaths for each operation in the Setup. The font color of all the listed operations in the Operation tree changes from magenta to black. This change in color indicates that toolpaths were successfully generated.

Note: If an operation displays in a magenta color instead of black even after the *Generate Toolpath* command has been executed, then it indicates that the toolpath has not been generated. This might occur in one of the following situations:

- When you insert a new operation interactively;
 - When you insert a new feature interactively and then generate operations for the new feature
 - When CAMWorks cannot generate the toolpath for an operation because of an error in the toolpath algorithm or when a parameter is not correct.
- Right click *Setup1* in the CAMWorks Operation tree and select *Sort Operations* on the context menu.
 - On the *Process* tab, remove the check mark from the *Process complete feature* option.

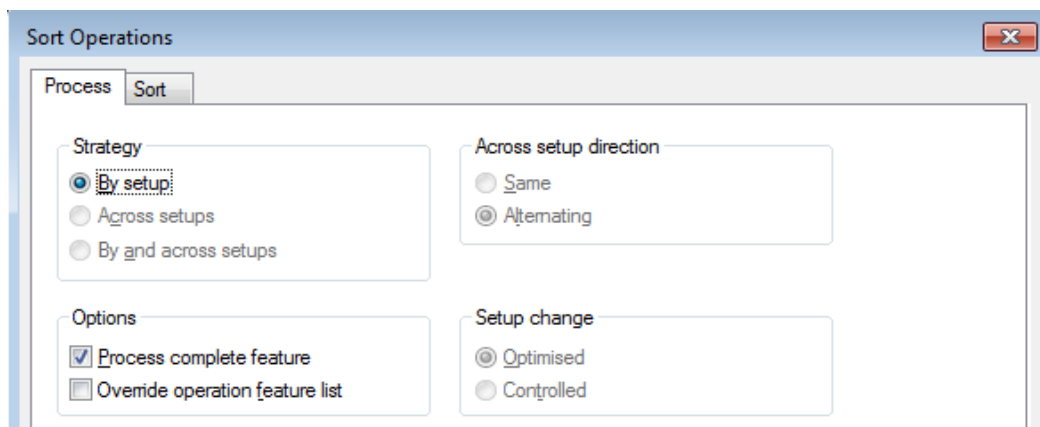

Remove the check mark from the 'Process complete feature' option

- Click on the *Sort* tab.
- In the *Sort by Operation Type* group box, drag and drop operations so that *Rough Mill* is at the top of the list, followed by *Contour Mill*, *Center Drill*, and *Drill*.

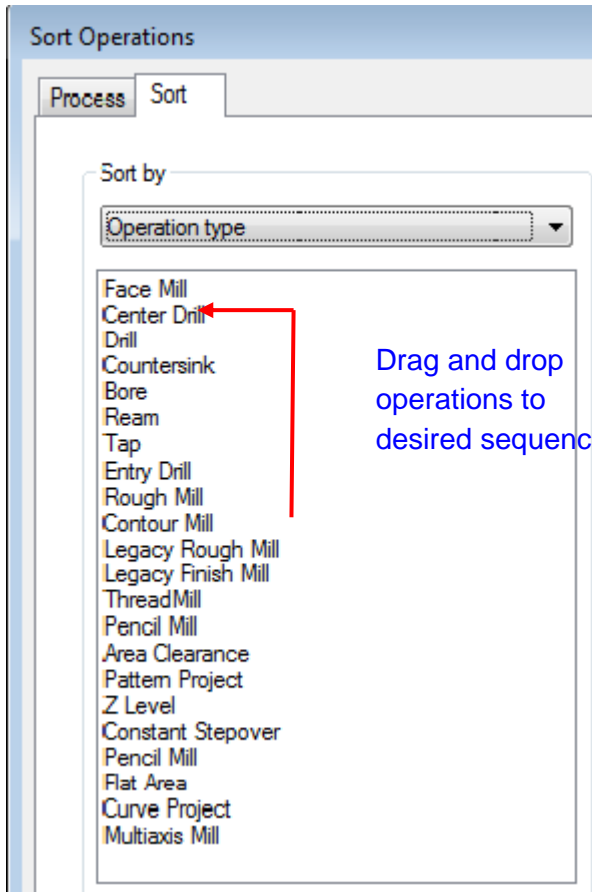

Operations before sorting

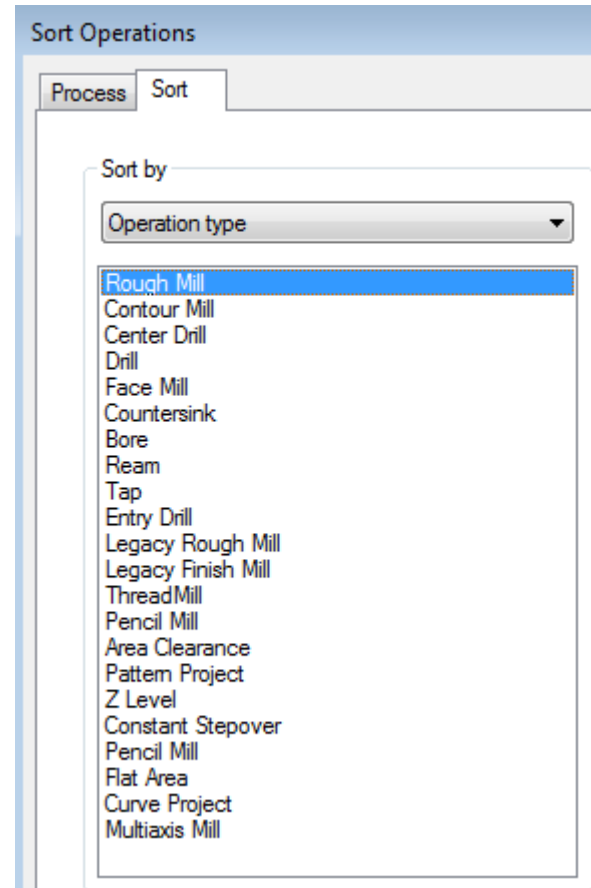

Operations after sorting

7. Click *Apply* button and confirm that the tree view updates to sort the operations according to this order. If it updates as expected, then click *OK*.

The operations under *Setup1* are sorted based in the order on the Sort tab.

8. Left click any operation in the CAMWorks Operation tree. That operation will be highlighted in the Operation tree.
 - The toolpath for that highlighted operation will be displayed in the graphics area. As you highlight each operation in the tree, the toolpaths for that corresponding operation will be displayed.
 - Turning operation parameters can be edited and the operation can be renamed, moved, suppressed, deleted, etc. after toolpaths have been generated. These commands are available in the RMB context menu.
 - If you make any changes, the toolpaths must be updated by executing the *Generate Toolpath* command again at the Setup level.
9. Hold down the *Shift* key and select the first and last operation in the tree. This action selects all the operations. The toolpaths for all the operations will be displayed on the part showing the centerline of the toolpath.

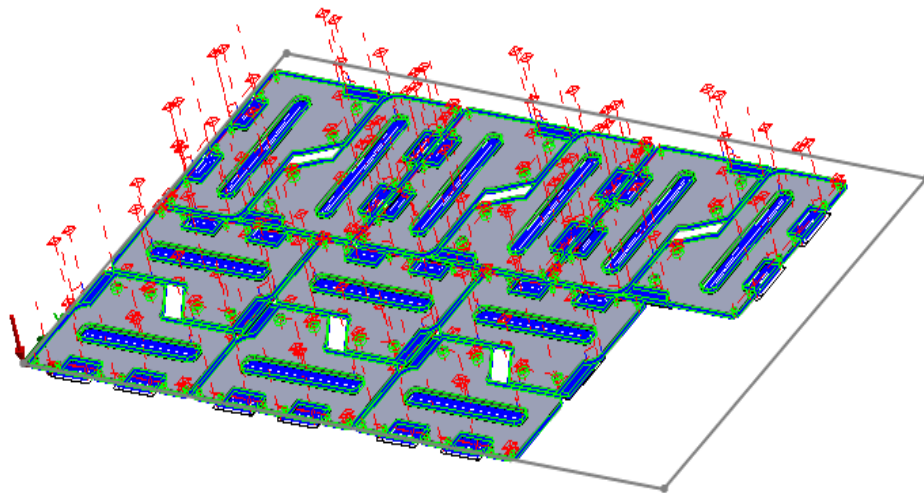

Toolpaths for all the operations displayed on the part when all the operations are selected in the Operation tree

Step 11: Simulate Toolpaths

CAMWorks provides the ability to simulate the toolpaths showing the tool movement and the resulting shape of the part.

1.  Click the *Simulate Toolpath* button on the CAMWorks Command Manager.

OR

Right click on *Setup1* in the Operation tree and select *Simulate Toolpath* on the context menu.

The Toolpath Simulation toolbar is displayed.

When you click on the display control buttons of the Toolpath Simulation toolbar, the available settings associated with that button are displayed in a dropdown list.

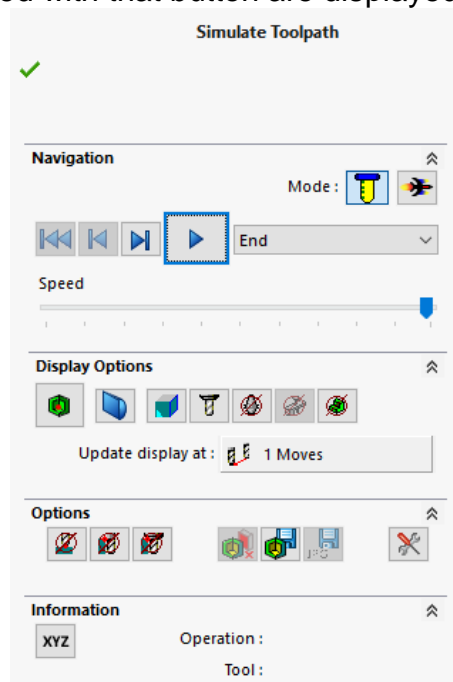

Simulate Toolpath Dialog Box



2. Set the following display options:
 - Stock: *Translucent display*
 - Tool: *Shaded display*
 - Tool Holder: *Shaded display*

3.  Click the *Run* button.

The simulation is run with the tool displayed during simulation.

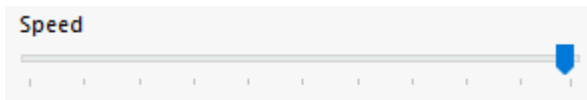

4. Use the Simulation Speed Control slider to control the speed of the Simulation.

5.  To pause the simulation while it is

running, click on the *Pause* button. When you click  *Run* button again, the Simulation will continue from the point where it was paused.

6.  Click the *Close* button in the upper right corner of the Simulation toolbar to exit the simulation mode and return to the SOLIDWORKS display.

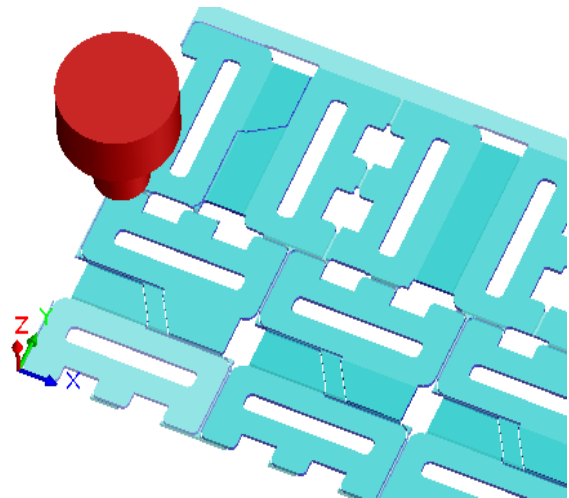

Toolpath Simulation

Step 12: Post Processing Toolpaths

Post processing is the final step in generating the NC program file. When you use a CAMWorks internal post processor, this step translates generalized toolpath and operation information into NC code for a specific machine tool controller. CAMWorks creates NC code for each toolpath in the order the operation appears in the CAMWorks Operation tree. When you post process a part, CAMWorks creates two files: the NC program and the Setup Sheet. These are text files that you can read, edit and print using a word processor or text editor.

In this tutorial, you will post process all the operations and generate the NC program:

1. Click the *Post Process* button on the CAMWorks Command Manager.

OR

Right click on the *CAMWorks NC Manager* in the Operation tree and select *Post Process* on the context menu.

The *Post Output File* dialog box is displayed so that you can save the NC program file.



2. Typically, the NC program and Setup Sheet files are stored in the folder that contained the last part that was opened. If you want these files in another location, you can change the folder location.

Note: If the *Post Process* command is grayed out on the CAMWorks Command Manager or on any context menu, make sure that you have selected a post processor and generated the toolpaths. Refer [Step 11](#) in this tutorial.



3. In the *Post Output File* dialog box, click the down arrow to the right of the *Save as type* box.
4. CAMWorks provides a list of commonly used extensions that you can select. For this exercise, use the *.txt* extension.

Note: If you want change the default extension from *.txt* to one of the ones in the list or if you want a different file name extension for NC program files, you can edit or create a *.pinf* file and specify the new extension. For more information on making these changes, see the online Help.

5. In the *File name* textbox, type the suitable file name, and then click *Save* button.
6. The *Post Process Output* dialog box is displayed.
7. Click the *Step* button  on the control bar at the top.
8. CAMWorks starts to generate the NC program and the first line of NC code displays in the NC code output view box. The post processing mode is set to post process one line of code at a time (Step mode).
9. Click the *Step* button. The next line of NC code is displayed.
10. Click the *Run* button . Post processing continues until it is completed.
11. When the post processing is finished, view the code using the vertical scroll bar.
12. Click *OK* to close the dialog box.

Note: To understand the complete the process from defining the machine and extracting the machinable features to simulating toolpath and generating the NC code for nested parts using the CAMWorks, refer the *Mill Assemblies Tutorial* of CAMWorks. To locate the tutorial, select the *Start* menu on the *Windows* taskbar and follow the path:

[All Programs>>CAMWorks201Xx64>>Manuals>>Mill Assemblies Tutorial](#)



TUTORIAL 13 – GENERATING NC CODES FOR NESTED LAYOUTS USING CAMWORKS (II)

Topics covered in this Tutorial:

- [Functionality to link NESTINGWorks with CAMWorks](#)
- [Tutorial illustrating how to generate NC Codes for Nested Layouts using CAMWorks](#)

In this tutorial, you will learn how to generate NC codes for nested layouts using CAMWorks when the functionality to link NESTINGWorks with CAMWorks is enabled.

Functionality to link NESTINGWorks with CAMWorks

A functionality automatically link the nested layout output of NESTINGWorks as the input for CAMWorks.

When this functionality is enabled, the nested layouts output generated using NESTINGWorks will be automatically fed as the input assembly for CAMWorks. This is achieved by automatically listing all the nested parts in the *CAMWorks Part Manager* and auto-defining the common stock for the nested assemblies. This automation saves considerable time by reducing the steps required to generate the NC code.

The functionality links the NESTINGWorks application with the CAMWorks application. This linking is achieved by:

- Automatic addition of nested parts in nested layouts to CAMWorks Part Manager
- Automatic definition of the stock (from which the parts will be machined) in the CAMWorks Stock Manager.

Advantages of this functionality

After the nested layouts were generated, users had to manually add instances of the parts present in each nested layout to the *CAMWorks Part Manager*. The settings for the common stock too had to be manually defined. These steps could be time-consuming. The steps for adding parts to the *CAMWorks Part Manager* and defining the stock can be automated using this new functionality.

Refer the [flowchart in the previous tutorial](#) to gain an understanding of the steps involved in generating NC codes and the steps that are automated when this functionality is used.

Enabling the functionality

The option to link NESTINGWorks with CAMWorks is controlled from the NESTINGWorks configuration file **DefaultValues.ini** (explained in *NESTINGWorks Configuration and Associated Settings Guide*) through the flag "**AddPartstoCWManager**". The functionality is



enabled when the flag is set to “1” and disabled when the flag is set to “0”. By default, this option is enabled.

For more details, read: **Enabling/disabling the functionality to add nested parts to the CAMWorks Part Manager** (explained in NESTINGWorks Configuration and Associated Settings Guide).

How the functionality works

When enabled, the functionality works in the following manner:

1. After nested layouts are generated using NESTINGWorks, each nested layout will be listed in the *SOLIDWORKS Configurations Manager*.
2. The NESTINGWorks application will then check for the presence of the CAMWorks Add-In.
 - a. If the CAMWorks Add-In is not detected, then this functionality will not work.
 - b. If the CAMWorks Add-In is detected then this functionality will come into effect. The *CAMWorks Feature Tree* tab will be populated in the following manner:
 - i. If multiple nested layouts are generated after the nesting process, then each nested layout assembly will be listed under the *Configurations* item. If only one nested layout is generated, then it won't be listed under *Configurations* item.
 - ii. The parts (instances) present in each nested layout will be automatically listed in the *CAMWorks Part Manager*. (Users can delete unwanted parts listed in the *Part Manager* using the *Delete* option.)
 - iii. In the *CAMWorks Stock Manager*, a common stock of type *Extruded Sketch* will be automatically defined for the parts present in each nested layout.

Automatic Definition of Stock in CAMWorks Stock Manager

For each nested layout assembly input into CAMWorks, a common stock of type *Extruded Sketch* will be defined in the *CAMWorks Stock Manager*. The perimeter of the Sheet used to nest the parts will be used as the sketch for extruding. If Sheet sketch is not available (for example in cases where sheet was defined from a *.dxf file), then the stock of type 'Bounding box' will be used.

3. When the functionality to link NESTINGWorks with CAMWorks is enabled, then for each nested layout, the automatic definition of the stock in the CAMWorks Stock Manager will have the following properties:
 - The stock created will be a common stock from which all the nested parts will be machined.
 - The stock type will be *Extruded Sketch* where the dimensions (length and breadth of the cuboid stock will be derived from a sketch).
 - The sketch picked for defining this stock will be the sketch representing the dimensions of the sheet in which the parts are nested. (The sketch representing the dimensions of the sheet will be listed in the *SOLIDWORKS FeatureManger Design Tree* after the nested layouts are generated.)
 - The height of the stock will be equivalent to the thickness of the parts.



Tutorial illustrating Generation of NC codes for Nested Layouts

This tutorial is divided into two sections:

- [Section I](#) illustrates how to generate Nested layouts for the example parts using the NESTINGWorks application.
- [Section II](#) illustrates how to generate NC codes for the Nested layouts.

Section I: Generating Nested layouts

In this section, you will nest an assembly comprising two native sheet metal parts of different thicknesses.

1. In the configuration file **DefaultValues.ini** (located within the NESTINGWorks Installation folder), ensure that the flag **FixComponent** under [*NestingData*] section is set to '1'.
2. This setting will ensure that after the Nested layouts are generated, the parts in the Nested layout assembly do not get accidentally repositioned.
3. Ensure that both **NESTINGWorks 201Xx64** and **CAMWorks 201Xx64** are loaded as Add-Ins within SOLIDWORKS.
4. Open the assembly file named **Tutorial_13.SLDASM** located in the following folder location:

C:\ProgramData\NESTINGWorksData\NESTINGWorks 201Xx64\Examples\Tutorials\Assemblies\ Tutorial_13

This assembly file comprises of the following two sheet metal parts.

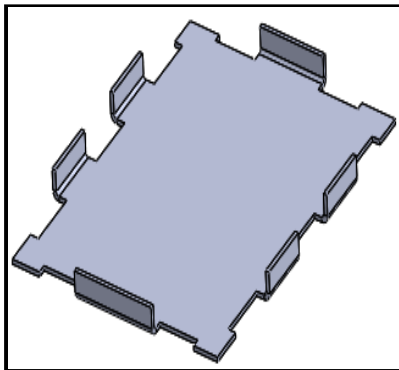

Tutorial_13_a.SLDPRT

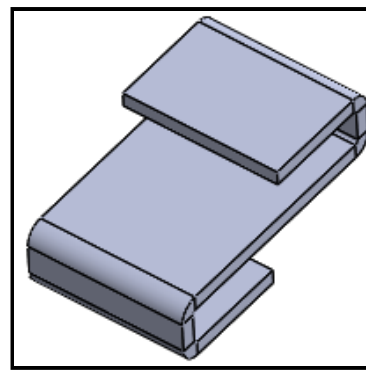

Tutorial_13_b.SLDPRT

5. Select the *Create Nest Job* command on the NESTINGWorks Ribbon bar.

OR

In the SOLIDWORKS menu bar, select Tools>>NESTINGWorks>>Create Nest Job.

Select Parts for Nesting dialog box is displayed. Tick on the parts checkbox. Click on Add and click on ok button.

6. The *Create Nesting Job* dialog box is displayed. In the *Part Data* tab, assign the following values to the various parameters:



Part	Thickness	Quantity	Material	Step Angle	Grain Direction
Tutorial_13_a.SLDPRT	1 mm	12	Steel	90 ⁰	None
Tutorial_13_b.SLDPRT	3 mm	12	Steel	90 ⁰	None

7. Since the two parts to be nested have different thicknesses, two different sheets of varying thicknesses corresponding to the parts need to be defined. In the *Sheet Data* tab, add two *Custom size* sheets with the following dimensions and values assigned to the parameters:

Sheet Name	Length (mm)	Width (mm)	Thickness	Material	Quantity	Grain Direction	Assembly Template
Custom Sheet1	500	200	1 mm	Steel	1	None	Default
Custom Sheet2	250	250	3 mm	Steel	1	None	Default

8. Within the *Multi head options* tab, in the *Machine Data* group box, ensure that the Machine selected is *SingleTHMachine* (a machine with a single tool head). The *Number of tool heads* for the machine will display 1.
9. In the *Options* tab:
- Assign a *Part to part distance* of **5mm** and *Part to sheet distance* of **5mm**.
 - Select *Fast Nesting* as the Nesting Type.
 - Ensure that the *Save output as dxf* option is unchecked.

Click on the *Preview Nest* button... to preview the Nested layout with available settings in *Create Nesting job* dialog box.

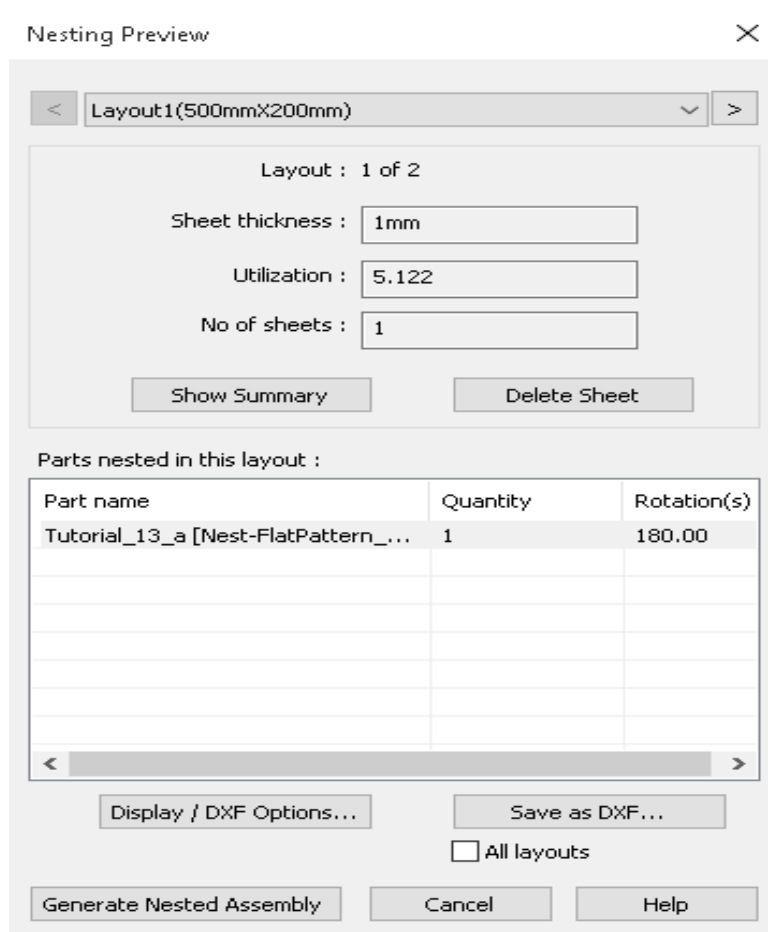

Nesting Preview dialog box

10. In the Nesting Preview window, when the result is satisfactory. Click on the Generate Nested Assembly button to execute the NestingWorks process.
This sets into motion the process to generate Nested Layout.
11. After the Nesting process is completed. NestingWorks will display a message indicating The location of the text file containing the **summary of the Nest Results**. Click OK to close the message. The text file will be displayed.
12. The **Nested layout assembly** will be displayed in the Graphics area. Both the summary file and the assembly files are saved in the location indicated Output Assembly File path stated in the *Create Nesting Job* dialog box.
13. Two nested layouts will be generated. These nested layouts will be saved as a SOLIDWORKS Assembly file (*.sldasm).
14. The Nest Result *Summary message box is displayed*. Click on ok, the text file is displayed indicating that all the parts have been nested. Close this text file.
15. In the SOLIDWORKS left hand side panel, click on the  SOLIDWORKS *ConfigurationsManager* tab. Observe that the nested layouts are listed under this tab.
You can switch the nested layout assembly currently displayed in the graphics area by double-clicking on the desired nested layout assembly listed under this tab.



16. Double-click on *Layout 2* to display it in the graphics area. (The first nested layout is usually displayed in the graphics area by default.)

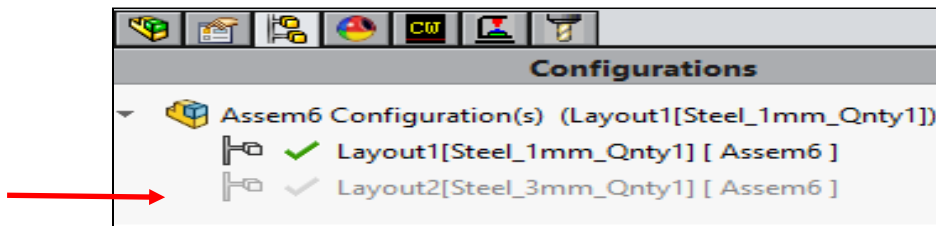

SOLIDWORKS ConfigurationsManager Tree

17. Click on the SOLIDWORKS *FeatureManager Design Tree* tab. Observe that the sketches for the three sheets are listed in this tab. These sketches will be used to define the common stock (of type *Extruded Sketch*) for each nested layout assembly.

Section II: Generating NC codes using CAMWorks

Step 1: Defining the Fixture Coordinate System for the Machine

The Fixture Coordinate System defines the “home point” or “main zero” position on the machine. It defines the default G-code origin, defines the XYZ machining directions and acts as a reference point, if subroutines are used. This coordinate system needs to be defined in the *SOLIDWORKS FeatureManager Design Tree*.

Following are the steps to define the Fixture Coordinate System:

1. If necessary, rotate and zoom the nested layout assembly in the graphics area to clearly view the position where you desire to assign the coordinate system.
2. Click the **Insert** menu on the SOLIDWORKS menu bar.
3. From the dropdown menu, select *Reference Geometry* and then select the *Coordinate System* from the cascading menu.

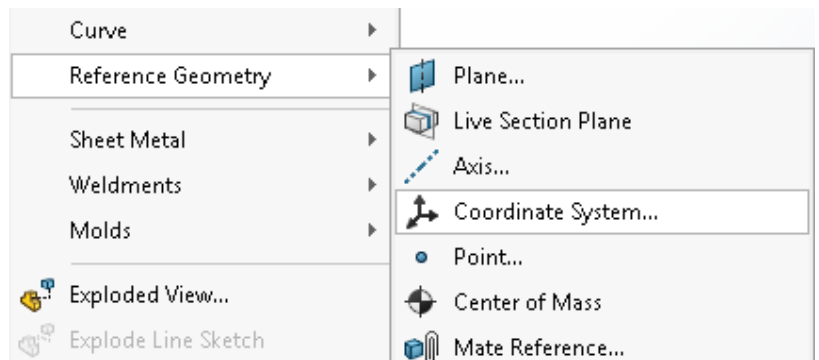

The *Coordinate System* dialog box is displayed.

4. In the graphics area, click on the point you wish to assign as the *Coordinate System origin*.

This action will display the selected coordinate system origin in the *Selection* field of the dialog box.

5. The XYZ machining direction should be same as displayed in the image on the right. If

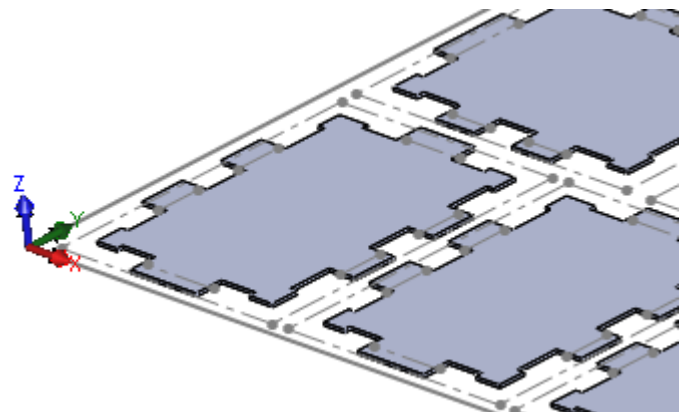

XYZ machining direction





necessary, click on the **Reverse Axis Direction** button to obtain the correct machining direction.

6.  Click the **OK** button to save the changes and close the dialog box.
The defined coordinated system is listed under the *FeatureManager Design Tree*.

Step 2: Defining the Machine

Before you machine the Nested layout assemblies, you need to define the Machine that will be used to machine the assembly.

1. In the SOLIDWORKS left hand side panel, click on the  *CAMWorks Feature Tree* tab. (Note that this tab will be visible only if CAMWorks is loaded as an Add-In within SOLIDWORKS)
2. Double-click on the  *Machine item (Machine [Mill - metric])* in this case) to open the *Machine* dialog box.
3. The Machine tab of the Machine dialog box is displayed. This tab allows you to select the machine that the assembly will be machine on. By default, either the *Mill - metric* or *Mill - inch* will be already selected.



If you wish to select any other Mill machine or a user-defined Machine definition, then highlight it in the Available Machines list and click the Select button.

4. Click on the *Tool Crib* tab, ensure that ***Tool crib1 (metric)*** is selected.



To select an alternative tool crib, select the desired tool crib In the Available tool cribs list box and click on the Select button.

5. Click on the *Post Processor* tab. This tab allows you to select a post processor for generating NC codes or for generating enhanced CL files that can be used by external third party post processing programs.

By default, the sample post processor ***M3AXIS-TUTORIAL*** is selected. For this tutorial, this default post processor will be used.



If you wish to use another post processor or a customized post processor provided to you by your CAMWorks Reseller, then highlight the desired post processor in the Available list and click the Select button. If the post processor is not listed, then click on the Browse button to navigate to the folder where the post processor file is located.





6. Click on the *Setup* tab. This tab allows you to set the Fixture Coordinate System for the machine.
 - Since a 2.5 Axis/ 3 Axis Mill Machine will be used to machine the assembly, Indexing will remain set to None.
 - In the CNC comp options group box, ensure that the Calculate safe CNC comp toolpath option is checked.



- In the Fixture Coordinate system group box, highlight Coordinate System1 in the Coordinate systems list box.
- This highlighted entity will be displayed in the Selected entity list box.
7. Click *OK* to apply the changes and close the *Machine* dialog box.
8. In the *CAMWorks Feature Tree*, under the *Configurations* item, double-click *Layout 2* to display it in the graphics area. Click *Yes* within the *Warning Message* dialog box displayed.
9. Double-click on the  **Machine item (Machine [Mill - metric]** in this case) to open the *Machine* dialog box.
10. Click on the *Setup* tab. This tab allows you to set the Fixture Coordinate System for the machine.
11. In the Fixture Coordinate System group box, highlight **Coordinate System1** in the *Coordinate systems* list box. This highlighted entity will be displayed in the **Selected entity** list box.
12. Click *OK* to apply the changes and close the *Machine* dialog box.

Step 3: Verifying the Addition of Parts in the CAMWorks Part Manager

With the new functionality to link NESTINGWorks and CAMWorks, for each Nested layout, the nested parts will be automatically added to the *CAMWorks Part Manager*. In this step, you will verify the automatic addition of parts to the *CAMWorks Part Manager* for each nested layout.

1. In the SOLIDWORKS left hand side panel, click on the  *CAMWorks Feature Tree* tab.
2. Within this tab, click on the (+) plus sign to expand the  *Configurations* item. Observe that the two nested layout assemblies generated are listed under *Configurations*. (Note that if only one nested layout is generated after the nesting process, then it will not be listed under *Configurations*.)
3. Expand the *Part Manager* item (if not already expanded) by clicking on the (+) plus sign to its left. Under *Part Manager*:
 - The part name (*Tutorial_13_a.SLDPRT*) is listed under the *Part Manager*.
 -  A *Feature Manager*, which is created for each part, is used to define the Mill Part Setups and machinable features associated to the seed part.
 -  For each unique part, all the instances are listed under the *Instances* item. Observe that all 12 instances of the part in the nested layout assembly are listed.
 - When you highlight an instance of the part listed under *Instances*, the corresponding part will be highlighted in the graphics area.
 - To delete an instance of the part, highlight the instance of the part under *Instances* and press the *Delete* button.
4. Under the *Configurations* item, double-click *Layout 2*. Click *Yes* within the Warning Message dialog box displayed. The graphics area will now display the second nested layout assembly.



(Alternatively, you can change the nested layout displayed in the graphics area by using the *SOLIDWORKS ConfigurationsManager* tab.)

- Once again, expand the items listed under *Part Manager* and observe that all the instances of the part (*Tutorial_13_b.SLDPRT*) have been listed under *Part Manager*.

Step 4: Automatic Stock Definition

With the new functionality to link NESTINGWorks and CAMWorks, for each Nested layout, the stock definition will be automatically loaded in the *CAMWorks Stock Manager*.

The *Stock Manager* allows you to customize the stock associated with the parts. In this step, you will verify the stock definition that was automatically defined in the *CAMWorks Stock Manager*.

- In the *CAMWorks Feature Tree*, under the *Configurations* item, double-click *Layout 1* to display it in the graphics area. Click *Yes* within the *Warning Message* dialog box displayed.
- Double-click on the *Stock Manager* item in the CAMWorks Feature tree.

OR

Right click *Stock Manager* item in the CAMWorks Feature tree and select *Edit Definition* on the context menu.

- The *Stock Manager* dialog box is displayed. Observe that:
 - In the *Stock Type* group box, the



selected Stock Type is **Extruded Sketch**.

- In the *Extruded Sketch* group box, the  *Depth* of the stock is set to **1mm**. (This is equal to the thickness of the parts being nested).
- In the *Stock Size* group box, the dimensions of the stock in the X, Y and Z directions are indicated. The **X** (500 mm) and **Y** (200 mm) values correspond to the dimensions of the sheet used for creating the nested layout. The **Z** value (1mm) is equal to the thickness of the parts being nested
- In the *Create Stock* group box, the Stock form selected is **Common** Stock. (This selection indicates that all the parts in the nested layout assembly will be machined from a common stock.)

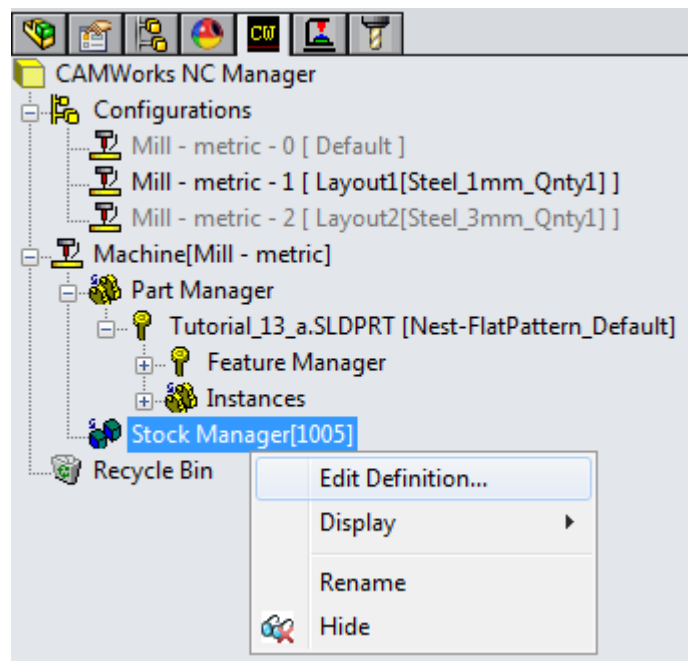

Command to open the Stock Manager dialog box

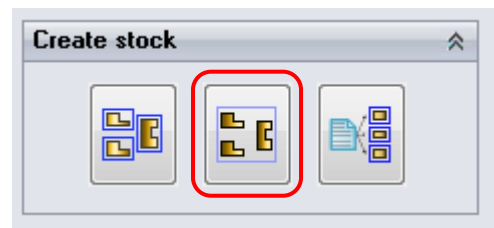

'Common' is selected in the Create Stock group box



4.  Click *Cancel* to close the *Stock Manager* dialog box.
5. If required, you can similarly check the stock definition for the *Layout2*.

Step 5: Defining Machinable Features and Interactively Inserting Features

Extracting Machinable Features for Layout 1:

The next step is to interactively insert Boss features after extracting the machinable features using the **Automatic Feature Recognition (AFR)** technology available in CAMWorks. Machinable Features thus recognized are added under the  *Feature Manager* item of the *CAMWorks Feature Tree*.





At the Mill Part Setup level, features can be inserted interactively using the New 2.5 Axis Feature or New Multi Surface Feature commands. CAMWorks automatically copies the features to every other instance of the part selected in the Part Manager.



When machining multiple instances of the same part, if you only want to create one instance of the feature, you can use the Assembly Feature command on the feature context menu to declare the feature an Assembly Feature. By doing so, CAMWorks will not copy the feature to all instances of the part.

In this tutorial, you will discard the machinable features that were extracted automatically by executing the *Extract Machinable Features* command since the machinable features recognized are not suitable for sheet metal machining. Instead, you will interactively insert the Boss Features that define the perimeter of the part.

Following are the step to recognize features automatically:

1. Ensure that *Layout 1* is displayed in the graphics area.
2.  Click the *Extract Machinable Features* button on the *CAMWorks Command Manager*.
OR
In the SOLIDWORKS menu bar, click on the *CAMWorks* menu and select *Extract Machinable Features* command.
OR
Right click *CAMWorks NC Manager* in the *CAMWorks Feature tree* and select *Extract Machinable Features* on the context menu.
3. The *Message Window* is displayed. This window is displayed automatically to report the progress of the current process. Close this message window.
4. On execution of the *Extract Machinable Features* command, CAMWorks generates the Mill Part Setup and the machinable features. The items are displayed in the *CAMWorks Feature tree*.
5.   Click the plus sign next to the *Feature Manager* in the *Feature tree*.
The *Feature Manager* displays all the Mill Part Setups and machinable features that were created by *Automatic Feature Recognition*.



Deleting the Mill Part Setups and Features from Layout 1:

In this tutorial, you will have to delete Mill Part Setups and features and then insert the Boss Feature interactively.

1. Press the *Ctrl* key on the keyboard and left-click on *Mill Part Setup2*, *Mill Part Setup3*, *Mill Part Setup4* and *Mill Part Setup5* in the Feature Manager to highlight the items.
2. Right click on the *Mill Part Setup5* and select *Delete* on the context menu.
3. CAMWorks will display a warning message asking whether you are sure about deleting the Mill Part Setups and all dependent items. Click *Yes* to confirm to deletion.

4. The features are moved to the Recycle Bin. When a feature is deleted, it is automatically placed in the Recycle Bin, which is used to store machinable features that you do not intend to machine.
5. Click the (-) minus sign to the left of the Recycle Bin to collapse it.
6. Similarly, you will delete all the features extracted in the *Mill Part Setup1*.
7. Under *Mill Part Setup1*, click on the first feature (*i.e. Rectangular Slot 1*) and hold down the *Shift* key on the keyboard and then click on the last feature (*i.e. Rectangular Slot Group3*) to highlight all the items.
8. Right click and then select *Delete* on the context menu. Click *Yes* to confirm the deletion.

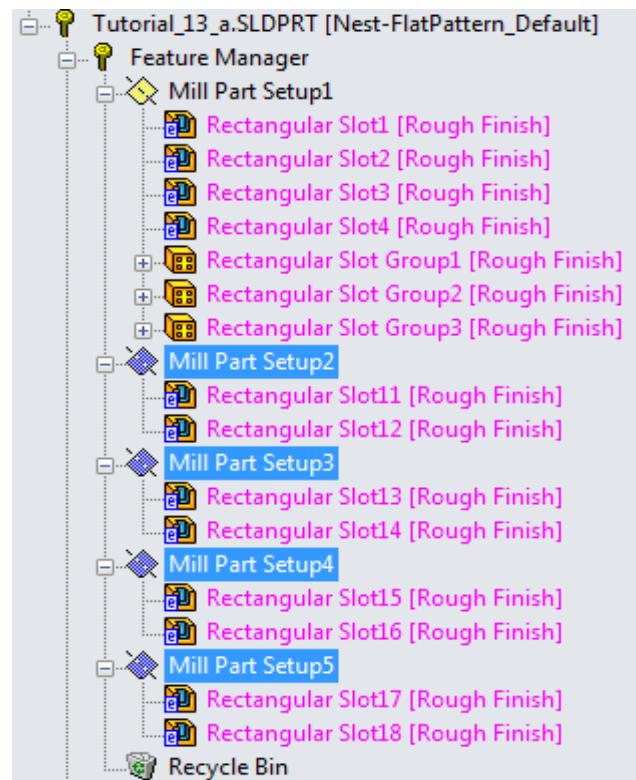

The features are moved to the Recycle Bin.

9. Right click on the *Recycle Bin* under the Feature Manager and select the *Empty* on the context menu.
10. CAMWorks will display a warning message asking whether you are sure about emptying the Recycle Bin. Click *Yes* to confirm the process.

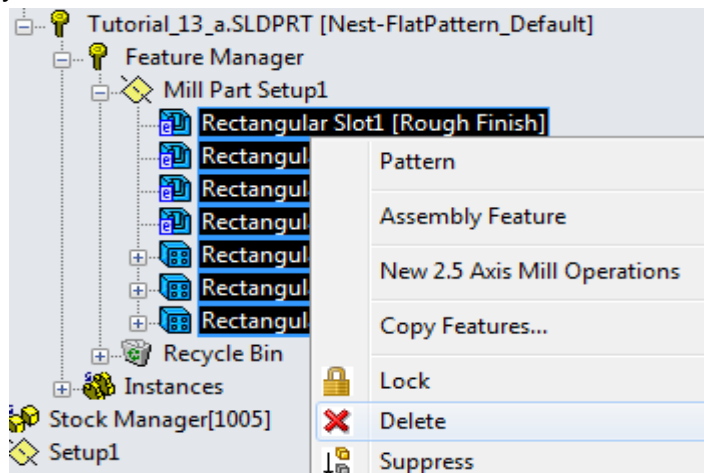

Deleting all the features from Mill Part Setup1



Interactively inserting Boss Feature in Layout 1:

After deleting the unwanted features and Mill part Setups, you will now interactively insert the Boss Feature by using the *New 2.5 Axis Feature* command.

Following are the steps to insert the boss feature interactively:

1.  Right click on the *Mill Part Setup1* in the *CAMWorks Feature tree* and select the *New 2.5 Axis Feature* command on the context menu.

The *2.5 Axis Feature Wizard: Feature & Cross Section Definition* dialog box is displayed.

2. Select *Boss* as the Feature type from the dropdown list.
3. Highlight in the *Entities selected* field to set the focus.
4. Select the lower edge of the left corner part in the graphics area as shown in the image on right (*highlighted in orange*).

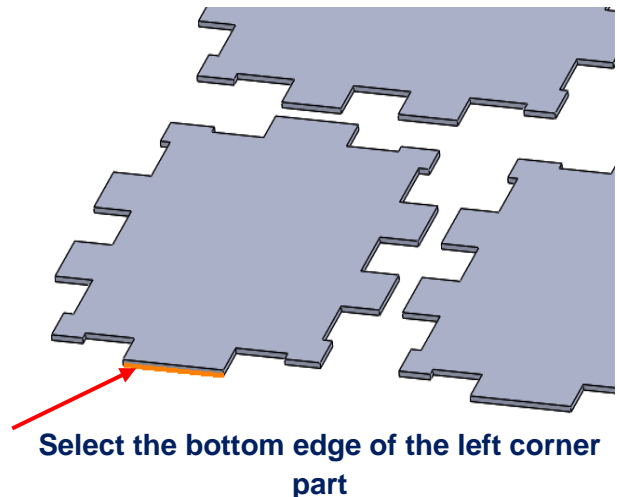

This action will display the *Loop <1>* in the field of *Entities selected*.

5. Click *Next* to display the *2.5 Axis Feature Wizard: End Conditions* dialog box.
6. Set the depth to **1mm**. (This is equal to the thickness of the parts being nested).
7. If required, remove the check from the check box next to the *Reverse direction* option in order to correct the direction.
8. Click *Finish* to insert the Irregular Boss feature under the *Mill Part Setup1*.
9. Click *Close* to exit the *2.5 Axis Feature Wizard* dialog box.

Observe that the interactively inserted Boss feature is listed under *Setup1* at the bottom of the *CAMWorks Feature Tree*.

Interactively Inserting Mill Part Setup and Machinable Feature For Layout 2:

For Layout 2 in this tutorial, you will insert both the Mill Part Setup and Boss Feature interactively.

Following are the steps to interactively insert Mill Part Setup and machinable feature:

1. In the *CAMWorks Feature Tree*, under the *Configurations* item, double-click *Layout 2* to display it in the graphics area. Click *Yes* within the *Warning Message* dialog box displayed.
2. Right-click on the *Feature Manager* under the *Tutorial_13_b.SLDPRT* of *CAMWorks Feature tree* and select *New Mill part Setup* on the context menu.

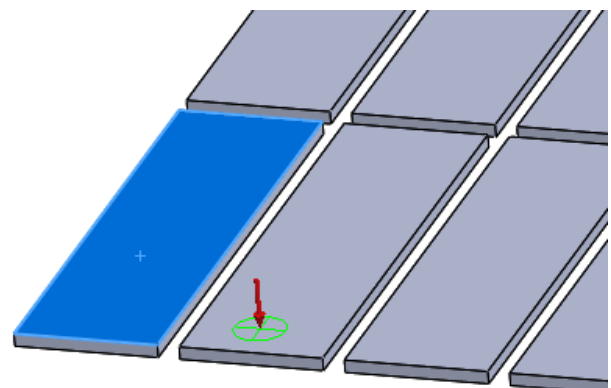



The *Mill Part Setup* dialog box is displayed.

3. Click on the left corner side part in the graphics area as shown in the image on right (*highlighted in blue*).
4. Make sure the direction (*indicated by red arrow*) is correct on the feature. If not, place a check in the check box next to the *Reverse direction* option.
5. Click *OK* to insert the setup and close the dialog box.

Mill Part Setup1 is now listed under Feature Manager in the tree.

6.  Right click on the *Mill Part Setup1* in the CAMWorks Feature tree and select the *New 2.5 Axis Feature* command on the context menu.

The *2.5 Axis Feature Wizard: Feature & Cross Section Definition* dialog box is displayed.

7. Select the Feature type as *Boss* from the dropdown list.
8. Click within the *Entities selected* field to set the focus and select the left corner part in the graphics area.

This action will display the *Face <1>* in the field of Entities selected.



9. Click *Next* button to display the *2.5 Axis Feature Wizard: End Conditions* dialog box.
10. Set the depth to **3mm**. (This is equal to the thickness of the parts being nested).
11. If required, remove the check from the check box next to the *Reverse direction* option to correct the direction of the defined feature.
12. Click *Finish* to insert the Rectangular Boss feature under the *Mill Part Setup1*.
13. Click *Close* to exit the *2.5 Axis Feature Wizard* dialog box.

Step 6: Sorting Part Instances to Determine Machining Order

When part instances are automatically added or manually added using the *Add All Instances* button, the instances need not necessarily be listed in the best machining order. CAMWorks provides options for sorting part instances to be processed in a more efficient order.

The order in which the part instances are listed under the feature is the machining order for that feature. By default, the parts for all features are in the order they appear in the *Part Manager*. You can change the order globally for all features or for individual features.

Following are the steps to sort instances:

1. Ensure that *Layout 1* is displayed in the graphics area.
2.  Under *Setup1* in the CAMWorks Feature tree, click on the (+) plus sign next to the feature to expand the feature items.
3.  Double click *Part Manager* in the CAMWorks Feature tree.
4. Click the *Sort Instances* button in the Manage Parts dialog box.
The *Sort Instances* dialog box is displayed.
5. Select the *Grid pattern* option.



6. Set the following options for Grid Pattern and then click the *OK* button.
 - Start corner = *Bottom left*
 - Direction = *Horizontal*
 - Pattern = *Zigzag*
7. Click *OK* to close the *Manage Parts* dialog box.
8. Click the (+) plus sign next to any feature listed under *Setup1* and click each part instance to view the machining order of the features in the graphics area.
9. In the *CAMWorks Feature Tree*, under the *Configurations* item, double-click *Layout 2* to display it in the graphics area. Click *Yes* within the *Warning Message* dialog box displayed.
10. Repeat the same steps from **2 to 8** for *Layout 2*.

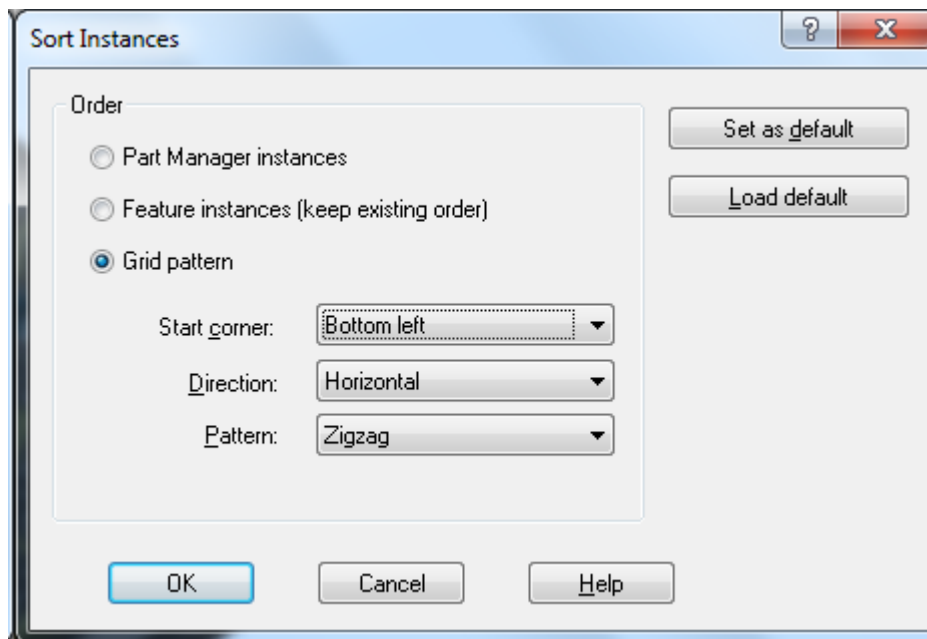

Sort Instances Dialog Box

Step 7: Generating the Operation Plan and Adjusting Operation Parameters

When Generate Operation Plan command is executed, operations for machinable feature are created automatically based on information in the CAMWorks Technology Database.

Generating Operation Plan for Layout 1:

1. Ensure that *Layout 1* is displayed in the graphics area.

2.  Click the *Generate Operation Plan* button on the CAMWorks Command Manager.

OR

Right click the *CAMWorks NC Manager* of the Feature tree and select *Generate Operation Plan* on the context menu.

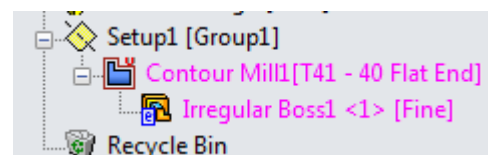

Generated Operation listed in Operation Tree



In the Operation tree, the generated operation *Contour Mill1* is displayed under *Setup1*.

Contour Mill1 operation is used for the Irregular Boss feature of the part.

3. In the Operation tree, double click *Contour Mill1*. OR
Right click *Contour Mill1* and select *Edit Definition* on the context menu.
The Operation Parameters dialog will be displayed.
4. Under *Tool* tab, click on the *Mill tool* page. Observe that a tool of 40mm diameter is used to machine the Irregular boss feature. This irregular boss feature represents the perimeter of the part. Since the *Part to part distance* and *Part to Sheet distance* assigned before creating the nested layout was 5mm, selecting any tool with more than 5mm diameter will gouge the part. Hence, the tool used to machine this operation needs to be changed to a tool with a diameter 5mm or less.
5. Click on the *Tool* tab and select the *Tool Crib* page.
6. Highlight the Flat End tool with diameter of **3mm** within the list of displayed tools.
7. Click the *Select* button. This action will assign the highlighted tool as the tool to be used for machining this operation.
8. CAMWorks will display a warning message which prompts you to select whether the corresponding holder of the tool is also to be changed. Click *Yes* to replace the corresponding holder.
9. Click *OK* to apply the changes and close the Operation Parameters dialog box.

Generating Operation Plan for Layout 2:

1. In the *CAMWorks Feature Tree*, under the *Configurations* item, double-click *Layout 2* to display it in the graphics area. Click *Yes* within the *Warning Message* dialog box displayed.

2.  Click the *Generate Operation Plan* button on the CAMWorks Command Manager. OR

Right click the *CAMWorks NC Manager* of the Feature tree and select *Generate Operation Plan* on the context menu.

In the Operation tree, the generated *Contour Mill1* operation is listed under *Setup1*. *Contour Mill1* operation is used for the Rectangular Boss feature of the part. For this operation too, the tool used to machine the operation needs to be replaced with a tool of 5mm or less.

3. Double click *Contour Mill1* in the Operation tree. OR
Right click *Contour Mill1* in the Operation tree and select *Edit Definition* on the context menu.

The Operation Parameters dialog box is displayed.

4. Click on the *Tool* tab and select the *Tool Crib* page.
5. Highlight the Flat End tool with diameter 5mm or less. For this tutorial, select the **4mm** diameter Flat End mill within the list for this operation and then click the *Select* button.

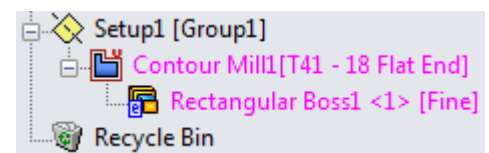

Generated Operation listed in Operation Tree



6. CAMWorks will display a Warning message. Click **Yes** to replace the corresponding holder.
7. Click **OK** to apply the changes and close the Operation Parameters dialog box.

Step 8: Defining G-code Program Zero Location

1. Ensure that *Layout 1* is displayed in the graphics area.
2.  Double click *Setup1* in the Operation tree.
The *Setup Parameters* dialog box is displayed.
3. On the *Origin* tab, make sure *Part Setup origin* is selected for the Output origin.
Note that when *Setup origin* is selected, you can specify the origin using several methods.
4. Click on the *Offset* tab.
5. In the *Sort by* group box, select *Grid pattern*.
When you pick this option, the parts in the table are automatically reordered based on the current settings for *Start corner*, *Direction* and *Pattern*.
6. Set the Grid pattern parameters to the same settings you used when sorting part instances for the machining order:
 - Start corner= *Bottom left*
 - Direction= *Horizontal*
 - Pattern= *Zigzag*
7. Set the Work coordinate offset to *Work Coordinate*. This option will output G54, G55, etc.
8. Set the *Start* value to **54** and the Increment to **1**.
9. Click the *Assign* button of the Work Coordinate offset group box. Observe that the numbers are updated in the *Offset* and *Sub* columns in the table.
10. Click **OK** to close the Setup Parameters dialog box.
11. In the *CAMWorks Operation Tree*, under the *Configurations* item, double-click *Layout 2* to display it in the graphics area. Click **Yes** within the *Warning Message* dialog box displayed.
12. Repeat the same steps from **2 to 10** for *Layout 2*.

Step 9: Generating Toolpaths

CAMWorks calculates toolpaths using the operation parameters to define how to machine each machinable feature.

1. Ensure that *Layout 1* is displayed in the graphics area.
2.  Click the *Generate Toolpath* button on the CAMWorks Command Manager.

OR

Right click *Setup1* in the Operation tree and select *Generate Toolpath* on the context menu.



On executing the *Generate Toolpath* command, the toolpath is generated for all the operations in the Setup.



3. Under the *Configurations* item, double-click *Layout 2* to display it in the graphics area. Click *Yes* within the *Warning Message* dialog box displayed.
4. Click the *Generate Toolpath* button on the CAMWorks Command Manager to generate the toolpath.

Step 10: Simulate Toolpaths

CAMWorks provides the ability to simulate the toolpaths showing the tool movement and the resulting shape of the part/assembly on machining the stock.

1. Ensure that *Layout 1* is displayed in the graphics area.
2.  Click the *Simulate Toolpath* button on the CAMWorks Command Manager.
OR
Right click on *Setup1* in the operation tree and select *Simulate Toolpath* on the context menu.
The *Toolpath Simulation* toolbar is displayed.
3. Set the following display options:
 - Stock: *Translucent display*
 - Tool: *Shaded display*
 - Tool Holder: *Shaded display*
4.  Click the *Run* button.
The simulation is run with the tool and holder displayed during simulation.
5.  Click the *Close* button to exit the simulation mode and return to the SOLIDWORKS display.
6. To view the toolpath simulation for *Layout 2*, switch the display to *Layout2* in the graphics area using the *SOLIDWORKS Configuration Manager* or *Configurations* item in the *CAMWorks Feature Tree* and follow the same steps.

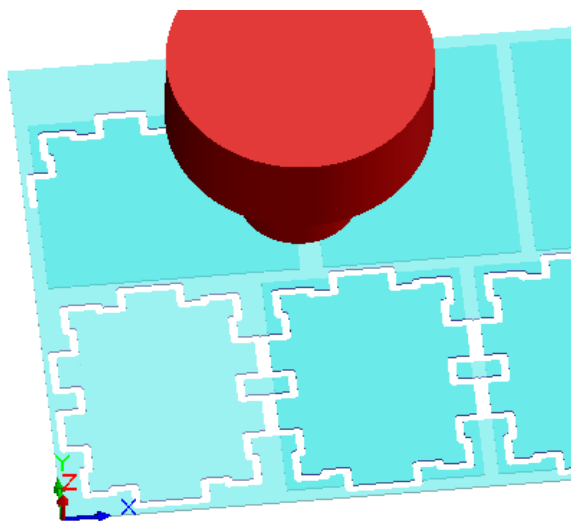

Toolpath Simulation for Layout 1

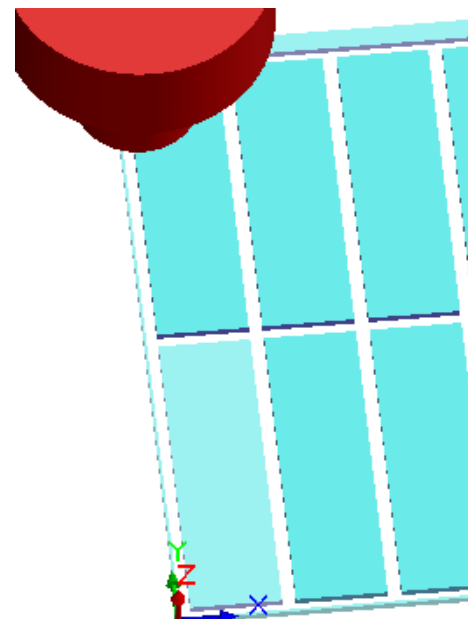

Toolpath Simulation for Layout 2



Step 11: Generate the NC code

Following are the steps to generate the NC program. Note that NC code needs to be generated separately for *Layout1* and *Layout2*.

1.  Click the *Post Process* button on the CAMWorks Command Manager.



OR

Right click on the *CAMWorks NC Manager* in the Operation tree and select *Post Process* on the context menu.

The *Post Output File* dialog box is displayed so that you can save the NC program file.

2. By default, NC files are stored into the folder that contained the last part model or assembly that was opened in SOLIDWORKS. If you want to save these files in another location, you can change the folder location.
3. In the *Post Output File* dialog box, type the suitable file name, and then click *Save* button.

The *Post Process Output* dialog box is displayed.

4. Click the *Step* button  on the control bar at the top of the dialog box.
5. CAMWorks begins to generate the NC program and the first line of NC code displays in the NC code output view box.
6. Click the *Step* button again. The next line of NC code is displayed.
7.  Click the *Run* button. Post processing continues until it is completed.
When the post processing is finished, view the code using the vertical scroll bar.
8. Click *OK* to close the dialog box.
9. Repeat the steps 1 to 8 for *Layout2* in order to generate NC code for it.