

SMOKE OR SUBSTANCE? . . . SOME MISCONCEPTIONS ABOUT DESIRABLE CONSTRUCTION FEATURES OF CENTRIFUGAL PUMPS

by

Igor Karassik

Dresser Industries, Inc.

Maplewood, New Jersey



Igor J. Karassik retired as Chief Consulting Engineer, Dresser Pump Division, Dresser Industries, Incorporated. He was employed by Worthington in 1934, and was engaged in research and design work. Since that time, he has served in numerous capacities at Worthington, including specialization in the application of multistage high pressure pumps, power stations, Manager Multistage Pump Section, Consulting Engineer and Assistant Vice President, Manager of Planning, Pump and Heat Transfer Division, General Manager, Advance Products Division, and Vice President and Chief Consulting Engineer. He is now a Consulting Engineer, based in Maplewood, New Jersey.

Mr. Karassik has written numerous articles on centrifugal pumps and steam power plants for technical publications. He is also the author of the books *Centrifugal Pumps Selection, Operation and Maintenance*, *Engineers Guide to Centrifugal Pumps*, and *Centrifugal Pump Clinic*, co-author of *Pump Questions and Answers*, and co-editor of *The Pump Handbook*. Mr. Karassik received his B.S. and M.S. degrees from Carnegie Institute of Technology. He is a Life Fellow of ASME and is a Professional Engineer in the State of New Jersey. He is also a member of Tau Beta Pi, Pi Tau Sigma, and Sigma Xi.

In 1980, he was awarded the first ASME Henry R. Worthington Medal. In 1981, he was elected an honorary member of the Russian-American Engineers Association.

INTRODUCTION

I have no reason to believe that the field of centrifugal pumps has any more of a monopoly on a whole series of myths about various concepts of construction details than any other technological discipline. Some of these myths arose through sincerely acquired misconceptions about what should provide a more economical or reliable construction; others originated instead from the desire of the marketing or advertising arm of a manufacturing enterprise to create an imaginary technological superiority for a new product line. What I decided to accomplish in this tutorial is to examine a few of the myths that pertain to centrifugal pump construction and to try to shed some light on their origins as well as on their validity. More specifically, I have chosen six different details of construction wherein major differences in concept have evolved over the years, namely:

- The use of double vs single wearing rings
- An improved wearing ring built on a false premise
- Extra deep stuffing boxes
- Axially vs radially split inner casings of double-casing multistage pumps

- The balancing of the axial thrust of multistage pumps
- Differences of philosophy in the rotor design of multistage pumps

DOUBLE OR SINGLE WEARING RINGS?

This is an area where frequent arguments still arise between supporters of the practice of using double wearing rings and designers who feel that in most applications single wearing rings in the casing are sufficient. Who is right?

This is not question to which a simple unequivocal answer can be made. Depending on the circumstances, either type of construction may be superior to the other. Originally, of course, centrifugal pumps were built without any wearings either in the casing or on the impeller, as in Figure 1. To restore original clearances after wear had taken place, it was necessary either to build up the worn surfaces by welding or brazing and then true up the parts or by buying a new impeller with an oversize hub to fit the trued up casing fit. The idea of providing a renewable stationary ring (Figure 2) which fitted into the casing was an obvious improvement and, I imagine, occurred very early in the history of the centrifugal pump. I suspect that the idea of providing the impeller with its own renewable wearing ring (Figure 3) followed fairly quickly. Early centrifugal pumps were generally applied for large capacities and were operated at relatively low speeds. Consequently, the impellers were significantly large in diameter and the task of mounting these impellers on a lathe to true-up the wearing surfaces was not a very simple one. But the reason why the double ring construction was then extended all the way down to the smallest centrifugal pumps can probably be laid at the door of the advertising department of the early centrifugal pump manufacturers. What was logical and sound for large pumps was made to appear as logical and sound for all pumps. And the enthusiasm of

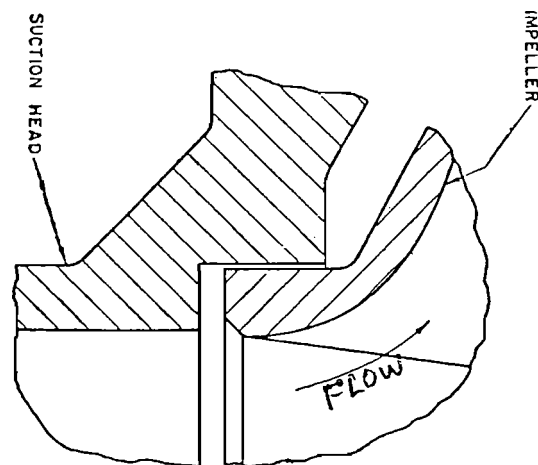

Figure 1. Leakage Joint with no Wearing Rings.

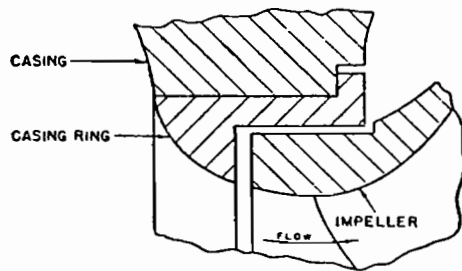

Figure 2. Renewable Stationary Casing Wearing Ring.

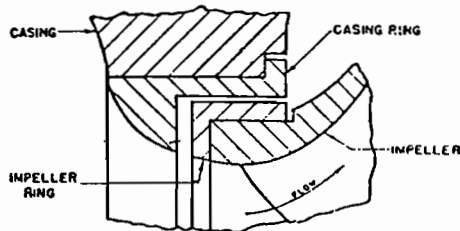

Figure 3. Double Wearing Rings.

advertising people led them to claim that the double ring construction permitted the user to discard both worn rings, replace them with newly bought parts and, without any further machining or adjustment work, restore the pump to its service with clearances equal to the original dimensions.

This claim is not quite true, however. The argument that the use of double rings permits their replacement without any machine shop work is incorrect. Mounting a new wearing ring on the impeller hub can distort the concentricity of the clearance turn, regardless of whether this impeller ring is screwed on, bolted on, or shrunk on the impeller. To preserve concentricity, it is imperative that after mounting the ring on the impeller, the outer turn of the wearing ring be checked by mounting the impeller on a lathe. In most cases, a slight truing-up cut will have to be taken.

Nor is the replacement of both rotating and stationary rings each time the clearances are to be restored economical. The maintenance mechanic who wishes to get the greatest mileage out of his repair parts will buy casing rings with undersize ID and impeller rings with oversize OD. The first time clearances are restored, he will retain the old impeller rings, limiting himself to truing-up their surface by mounting the impeller on a mandrel in a lathe. He then bores out the new casing rings to fit, being careful to store the worn casing rings. At the next go-round, he will true up the old casing rings taken out of storage, mount new impeller rings on the impeller and finish machine these to match his repaired casing rings.

But generally, it is neither economical nor practical to use double wearing ring construction for small pumps, say under four inch or six inch size. It is far better to restore the concentricity of the wearing surface. The repair casing ring is then bored out so as to restore the initial clearance. Impeller hubs are generally provided with sufficient metal to carry out such an operation as many as three or four times.

There are exceptions to the general rules suggested above. When it is desired to use expensive but more wear-resisting materials for the wearing ring construction regardless of pump size, because the impeller itself need not be made of any metal other than that required, let us say, for corrosion resistance. Thus, stainless steel impeller rings are frequently used on bronze or cast iron impellers. The second exception has to deal with pumps

operating at relatively high speeds and fitted with high grade impeller materials. It would be unnecessary to mount stainless steel impeller rings on a stainless steel impeller, since wear would probably be slow anyway, and since the impeller hub surface can be restored easily by truing-up. At the same time, the use of a wearing ring mounted on the impeller would introduce the hazard of it loosening up under the action of centrifugal force and causing severe damage to the pump.

Thus, the prospective purchaser of a centrifugal pump will be well advised to examine the reasons why a particular pump has double wearing rings or single wearing rings and to decide between the two on the basis of true merits and not that of catalogue or advertisement claims.

REVERSE THREAD WEARING RINGS

Reverse thread wearing rings are another example of certain myths having to do with centrifugal pumps; this one has to do, again, with wearing rings. Many years ago, pump designers conceived the thought that if the stationary rings were provided with grooves or serrations (as in Figure 4), two distinct advantages would be gained:

- The several stages of deceleration and reacceleration that are created by the changes of area available for the leakage past the wearing rings would increase the hydraulic losses in the clearances and thus reduce the leakage.
- The presence of the recesses formed by the grooves would reduce the possibility of binding in the clearances caused by foreign matter. The particles that might migrate into the wearing ring clearance could lodge in these recesses. In addition, the mating surfaces would not present a long uninterrupted contact area and there would be less tendency to galling.

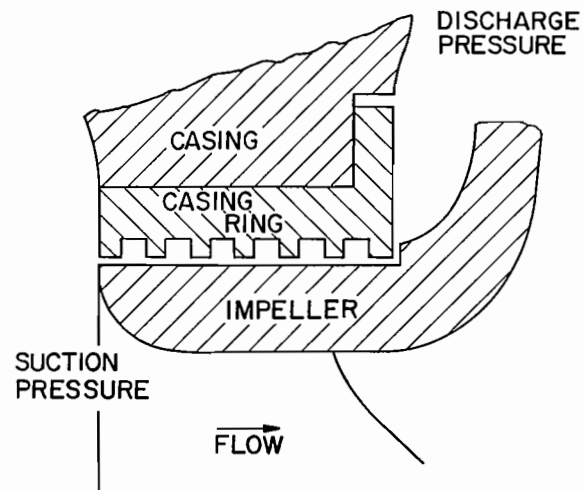

Figure 4. Casing Wearing Ring with Concentric Grooves.

There is no disputing these two facts and grooved casing rings do provide a real advantage. But the next development was not as logical. At some time after the concept of a grooved wearing ring was first introduced, someone conceived the notion that if instead of using separate grooves one were to substitute a thread running in a direction opposite to the pump rotation, a pumping action would take place. The leakage flow from the area under discharge pressure to that under suction pressure would be greatly reduced if not eliminated altogether. Reducing the wearing ring leakage would increase the pump efficiency. I am not certain whether a patent was taken out for the idea, but the pump manufacturer who

developed the concept certainly used it as an inducement to promote his pumps.

In fact, the concept is not valid: a reverse thread wearing ring can be compared to a very shallow Archimedes screw; in the capacities involved it is doubtful that its efficiency will exceed 10 to 20 percent. It is much more effective to let the leakage take place back to suction and then repump it through the impeller, with whatever the pump efficiency happens to be—probably in the 70 to 85 percent range.

“EXTRA DEEP” STUFFING BOXES

Extra deep stuffing boxes are another claim that used to appear with astonishing regularity in centrifugal pump advertisements. And yet, the claim is meaningless once it is examined in the cold light of logic. The vagueness of the claim becomes obvious when one considers that there are no definite standards by which one can judge the relative depth of a stuffing box. In other words, “what’s par for the course?” Add to this the fact that there is no written law to my knowledge which makes a pump with extra deep stuffing boxes superior to any other pump under all circumstances. In general, centrifugal pump stuffing boxes are designed to hold from five to nine packing rings, depending on the size of the pump and the pressure against which the stuffing box must be sealed. Since pump designers layout pump lines rather carefully, we must assume that barring an infrequent error—an error which would soon be discovered and remedied—stuffing boxes in centrifugal pumps are as deep as need be.

I spent many years nursing my pet peeve against “extra deep stuffing boxes” until, through no effort on my part, everyone realized the futility of such a claim and references to it eventually disappeared.

HIGH PRESSURE MULTISTAGE PUMPS

Let us look at another example of a mechanical problem which found more than one solution and, therefore, gave rise to controversy, which still finds strong adherents on opposite sides of a technical argument. This is the question of how one should build a high pressure multistage pump.

In the United States, the period between 1920 and 1940 was characterized by the very strong personalities that guided new developments in the various major companies producing centrifugal pumps. There was Hollander with Byron-Jackson, Petersen with De Laval, White with Allis-Chalmers, and Spillman with Worthington. It is probable that the philosophies developed by each one of these men are still forming the basis of the general approach taken by the engineering departments of the companies—even though the men at the head of these departments are young enough to have had no direct contact with their earlier counterparts. Let us pass rapidly over that period of centrifugal pump history during which pressure requirements were sufficiently low to permit the use of axially split casings and did not require the use of double casing construction that has become common place today for high pressure service. I shall merely note that until the 1940s, some split casing designs continued to use inline impellers, followed by a balancing device (as in Figure 5), while at least one company switched to the opposed-impeller style (Figure 6) with external interstage passages.

The impellers in this last design were so arranged (Figure 7) that the maximum pressure difference across any inner stage joint was limited to the pressure developed by one stage only. The advantage in such a design, of course, was the elimination of a running joint with a very high pressure differential, as occurs at the balancing device.

But pressures grew and as they reached certain limits, it became impractical to hold the flanges of an axially split casing tight against the internal pressure. For a short while, a design similar to

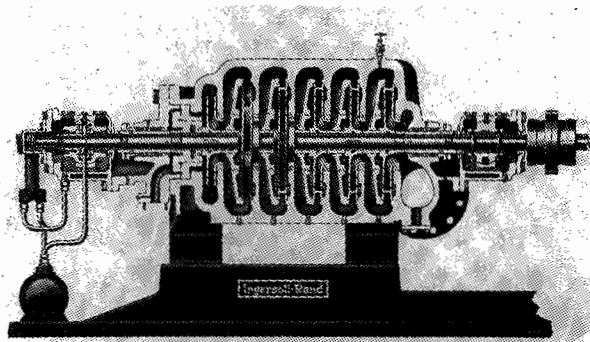

Figure 5. Multistage Pump with Single-Suction Impellers Facing in One Direction and Hydraulic Balancing Device.

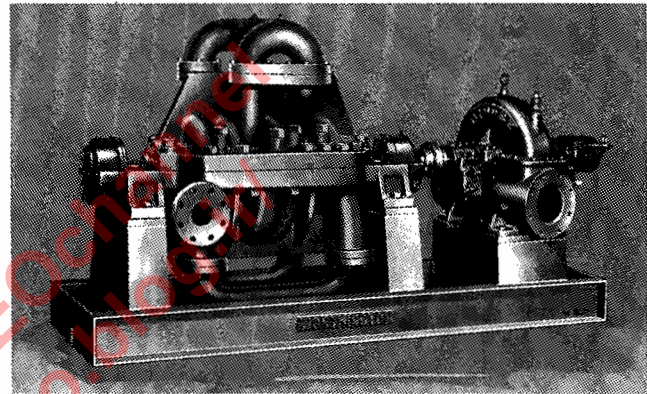

Figure 6. Six-Stage Axially Split Casing Volute Pump with External Interstage Passages.

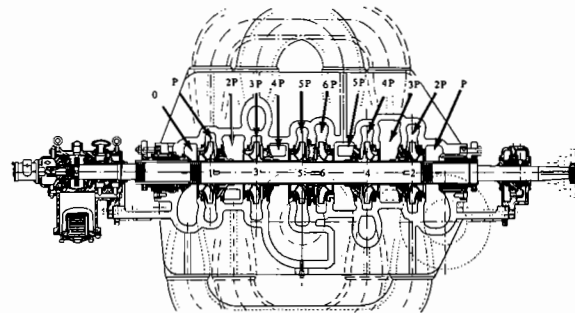

Figure 7. Section of Six-Stage Opposed-Impeller Pump. (Suction Pressure = 0. pressure generated by each stage = P.)

that still used to some extent in Europe was adopted. It consisted of building up a pump made of individual stages, each with its own stage piece, and the radially split individual stage units were bolted together into a complete pump with through-bolts (Figure 8).

I need not elaborate the fact that dismantling such a multistage pump presented considerable difficulties—especially since both suction and discharge connections had to be broken each time the pump had to be inspected or repaired. The double casing pump, built in the United States for the first time in 1934, was the logical solution to these difficulties. The modern evolution of this first double casing pump (illustrated in Figure 9), has a radially split inner casing.

But not all manufacturers in the United States followed this example. While ultimately some manufacturers did so, others

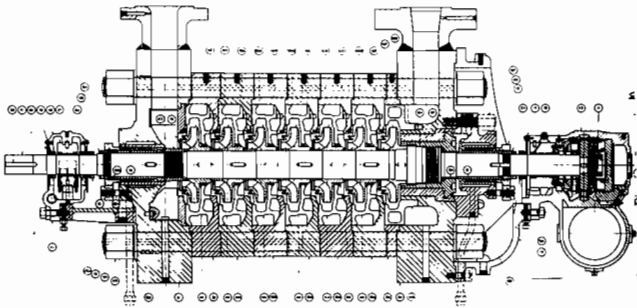

Figure 8. Segmental Boiler Feed Pump Built by Worthington in the Early 1930s.

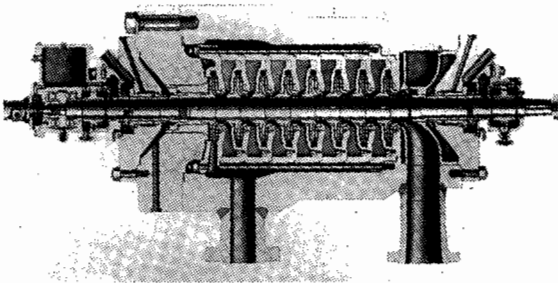

Figure 9. Section of Double-Casing, Radially Split Inner Casing Multistage High Pressure Pump.

preferred to use an inner casing that was split axially and which incorporated the "opposed-impellers" method of balancing the axial thrust. Why these two separate solutions? And is one of these superior to the other? I prefer not to answer this second question, for fear of being accused of prejudice. But I can certainly comment on the reasoning that was used in arriving at the second solution.

The difference in approach stemmed mainly from a basic disagreement over the priority that should be assigned to the ease in dismantling a high pressure pump. The proponents of the axially split inner casing claimed for it the advantage of greater accessibility (and, therefore, a shorter dismantling time) along with the possibility of acquiring a spare assembled rotor without the need of carrying a spare inner casing. This argument may have had validity in the early days of high pressure pumps, before the use of stainless steel internal parts and greater design experience lengthened pump life between overhauls to as much as 80,000 or more hours. But it is difficult to attach much importance to a difference of a few hours in the time required to dismantle a pump down to its individual components with the life expectancy of today's pumps.

BALANCING AXIAL THRUST

What of the difference in the method chosen to balance axial thrust? If the "opposed-impellers" pump developed in the middle 1930s was an improvement over the inline impellers and the balancing device, why should this not remain true in the double casing pump? After all, we are dealing with even higher pressures and, therefore, the reduction of pressure differentials across running joints must be even more effective in lengthening service life.

The trouble here, unfortunately, is that a design that was quite applicable to an axially split casing pump, namely the use of external interstage passages. The arrangement of stages depicted on Figure 6 was no longer practical once we enclosed this split inner casing in a second barrel casing. No longer could we afford to alternate the position of the individual stages and limit internal

pressures to that generated by a single stage. It became necessary to limit the number of interstage passages that traversed the outer space between the inner and outer casings. This eliminated the possibility of doing away completely with the balancing device. It is true that proponents of the "opposed impeller" arrangement claimed this elimination. But I shall be forgiven if I state that this was a "paper" elimination.

The total differential pressure generated by a multistage pump has to be broken down in either case. With inline impellers, this breakdown takes place across a single running joint (Figure 10 a). With opposed impellers (Figure 10 b), the balancing device is split up into three separate portions and distributed within the pump at points A, B, and C.

It is also given a different name, but that is strictly a matter of semantics. Since wear in a running joint is a function of the pressure drop per inch of running joint length, it will not be affected by the number of these joints nor by the pressure drop across them, as long as the lengths of these joints are chosen to maintain the same pressure drop per inch. The major advantage in favor of the single balancing device is that it is located in such a manner that the flow through it can be readily measured and thus can serve to monitor the progress of the wear experienced by the pump.

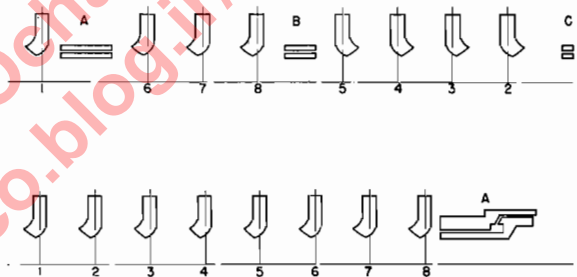

Figure 10. a) Joint 'A' is Subject to a Differential Pressure of Four Stages. Joint 'B' is subject to a differential pressure of three stages. Joint 'C' is subject to a differential pressure of 1 stages. Sum of pressure differentials is eight stages. Joint 'D' is subject to a differential pressure of eight stages; b) True balancing device.

PHILOSOPHY OF MULTISTAGE PUMP ROTOR DESIGN

Pump designers have always been split into two opposite camps with regards to the ideal choice of the number of stages for any given required total head and, even once this has been decided, to the proper choice of a shaft diameter for a given shaft span. Some engineers consider that pump efficiency is of paramount importance and takes precedence over all other considerations. This demands that the choice of the design specific speed be made as high as possible. Such a decision requires that the head per stage be relatively low and, hence, the pump will have a greater number of stages than might otherwise be used. Obviously, the shaft span increases. Unless one were to also to increase the shaft diameter, which would be counter productive to the desire for high efficiency, the static deflection increases dramatically and exceeds the internal running clearances. The only means of avoiding contact and rubbing between rotating and stationary parts is to depend on the hydrostatic and hydrodynamic bearing effect created by the leakage flow of the pumped liquid at all the pressure differential elements. This is commonly referred to as the "Lomakin effect," because the mathematical relationships governing the support provided by these internal bearings were first developed by Professor Lomakin of the Leningrad Institute of Technology in 1958.

The opposite view held by other pump designers is that reliability and continuity of trouble free operation are more important than pump efficiency. This leads them to choose a higher head per stage, a lesser number of stages, a shorter shaft span and a span-to-diameter ratio, such that the static shaft deflection is always less than the internal clearances.

What then are the arguments that can be marshalled against the first of these two conflicting philosophies? In fact, if a pump were to be started up only once in its lifetime and continue to run unstopped for a number of years, and if the internal parts were never to wear, so that the original clearances were never to increase, the effect of that philosophy would be the attainment and maintenance of the highest possible efficiencies— a most desirable result. The problem arises because neither of these two conditions can be expected to be met.

If the shaft deflection “in air,” (that is without taking into account any bearing effect provided by the wearing rings and the interstage bushings) is greater than the radial clearance, the rotor will rest on the wearing rings and in the interstage bushings as long as the pump is at rest.

When the pump is started up, the Lomakin effect is inoperative until the rotor attains a speed sufficiently high to develop a head per stage which permits flow through the clearances and a hydrostatic/hydrodynamic effect is created. Thus, for a certain number of revolutions, the rotor will be rubbing in the clearances and wear will occur. These clearances will increase, even though this increase may be slight. Next time the pump is started, the rotor will still be resting in the stationary parts, although it will have a greater sag. The same process will take place each time the pump is stopped and the interstage pressure falls to a value insufficient to produce a bearing effect. This action will continue each time the pump is started or stopped, until the clearances will have increased sufficiently to exceed the natural deflection of the “long, slender” shaft.

One might think that the rubbing contact between rotating and stationary parts will be of such duration that the wear caused by this rubbing will be negligible. After all, this rubbing might continue for no longer than one to two seconds when the pump is started up and probably no longer than five to ten seconds when the driver is tripped out and the unit coasts down to rest. But I assure you that even short periods of rubbing contact are sufficient to cause significant wear.

If a pump becomes steam or vapor bound, there is no longer any lubricating film at the running joints and the shaft assumes the deflection it would have on the basis of a shaft operating in air and

a span corresponding to the distance between the two external oil-lubricated bearings. If this deflection exceeds the internal clearances, the rotor will again rub at the clearance joints. But now the rubbing action will be much more disastrous, since it may take place at full speed and for a much longer period of time. Even if we were to assume that a pump is never stopped after its initial start, wear in the clearances caused by liquid erosion will be taking place with the consequence that as time goes on, the rotor will deflect more and more, again until wear will have increased the clearances as described above and the shaft reaches its natural deflection with no bearing assistance from the wearing rings or the interstage bushings.

If the liquid being pumped contains particles of foreign matter, this process will be accelerated. If the static deflection causes the rotor to rest on the rings while the pump is idle, the foreign matter particles will be trapped in the bearing ring fits, and the rotor will act as a surface grinder each time the pump is started up, removing metal from the wearing rings and impeller hubs or impeller wearing rings. These considerations lead me to conclude that dependence on internal bearings for maintaining a multistage pump rotor free from internal contact cannot but lead to a more rapid growth of the dimensions of internal clearances. The slight advantage gained in efficiency when the pump is new disappears and the pump requires renewal of the internal clearances much more often than if the shaft span and diameter had been chosen more conservatively.

That this is true has been demonstrated on a large number of occasions. For instance, I have collected statistical data on two groups of high pressure multistage pumps on decoking service—a very severe application, because the water handled contains a significant amount of hard coke particles, and because these pumps are stopped and restarted as often as four times a day. For some 30 pumps with a conservative shaft design, the average life between the needed renewal of the internal clearances ran to 4.5 years. For an equal number of pumps with slender shafts that depended on the support of wearing rings and interstage bushings acting as internal bearings, this average life had decreased to 11 months.

I must add that there is a ray of hope that one of these days one might be able to have the best of two worlds—high efficiencies and high reliability. This will come about when the cost of magnetic bearings is reduced by as much as two orders of magnitude. These bearings will then be able to be installed in the interior portion of a multistage pump to assist the external oil lubricated bearings in reducing the shaft deflection. Since magnetic bearings do not depend on the existence of a pressure differential across a running clearance, the loss of support which occurs when the pump slows down or is at rest—the problem that I have discussed earlier—will no longer occur.

But until this happens, I am afraid that the chase after a few points in efficiency is a myth, if it is accomplished at the expense of reliability.

CONCLUSIONS

As said before, there are many circumstances when differences of opinion between pump designers have little effect on the reliability of the equipment or on the ultimate life between overhauls. Thus, the choice between these different designs is not overly important and the user will be well served regardless of the decision he makes in selecting the pump that he will install and operate. On the other hand, there are areas of design philosophy where the selection will have an important effect on customer satisfaction. The areas that I have chosen to discuss in this paper fall into this latter category. When the real roots of the differences in design philosophy are not based on fact, but rather on misconceptions and the desire to create a preference for a given product

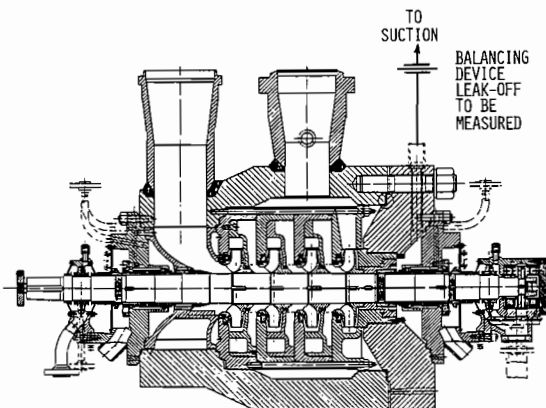

Figure 11. Deflection of Correctly Proportioned Shaft is Less than the Internal Clearances. This avoids contact at clearances when pump is at rest.

line, the user must try to analyze such claims from an informed point of view. I hope that this tutorial will help him or her to do so, to distinguish between fact and fiction . . . between smoke and substance.

<https://t.me/TEOchannel>
<http://teo-co.blog.ir/>