

Optimum Design of PSS and SVC Controller for Damping Low Frequency Oscillation (LFO)

Hossein Hosseini, Behrooz Tusi, Navid Razmjooy, Mohsen Khalilpoor

Abstract—Progressing of the demand for electrical energy leads to loading the transmission system close to their limits which may leads to LFO happening. Low frequency oscillations (LFO) in power system usually happen because of lack of damping torque to overcome disturbances in power system such as changes in mechanical power. Due to the existence of the low frequency oscillation (LFO), the transmission power of AC lines is limited and the system angle stability is affected. In this paper the Parameters of the classic PSS and SVC internal AC and DC voltage controllers are designed in order to damp the Low Frequency Oscillations (LFO). The design of PSS and SVC parameters is considered as an optimization problem and Hybrid Particle Swarm Optimization (PSO) and Genetic Algorithm (GA) are used for searching optimized parameters. The results of the simulation show that the SVC with PID controllers is more effective in damping LFO compared to PSS with PID controllers.

I. INTRODUCTION

Since 1960s, low frequency oscillations have been observed when large power systems are interconnected by proportionately weak lines [1]. The electro-mechanical low frequency oscillation between inter-connected synchronous generators is harmful to power system security and stability [2]. Nowadays the low frequency oscillations (LFO) have become the main problem for power system small signal stability. In order to increase power system oscillation stability, the installation of Supplementary excitation control, power system stabilizer (PSS) is a simple, effective and economical method [3],[4]. In the same times the advantages of using Flexible AC Transmission System (FACTS) controllers for improving power system stability are well known [5],[6]. FACTS controllers are also capable for controlling the network condition in a very fast manner and this feature can be used to improve the stability of a power system [7]. The FACTS devices may be connected so as to provide either series compensation or shunt compensation depending upon their compensating strategies [8]. In recent years, there are many researches which have been done in order to damp the LFO. A method to damp the LFO with TCSC in a Single Machine Infinite Bus (SMIB) system is presented by Abolfazl Jalilvand and Mohammad Reza Safari Tirtashi [9]. M. Zarringhalam et al proposed an optimal design of STATCOM and PSS with HPSO in SMIB system [10].

Hossein Hosseini is now with the Engineering Department of Urmia, Urmia, Iran (e-mail: uh.hosseini@gmail.com).

Behrooz Tusi is now with the Engineering Department of Urmia, Urmia, Iran (e-mail: b.tousi@urmia.ac.ir)

Navid Razmjooy is now with the Young Researchers club, Majlesi branch, Islamic Azad University, Isfahan, Iran (e-mail: navid.razmjooy@hotmail.com).

Mohsen Khalilpoor is now Young Researchers club, Ardabil branch, Ardabil, Iran (e-mail: m.khalilpour66@gmail.com).

LIU Zhijian et al used a fuzzy rule-based technique for damping LFO with TCSC [11]. In this study, in order to improve power system dynamic stability, voltage regulation and damping low frequency oscillation (LFO), static var compensator (SVC) and power system stabilizer (PSS) have been used. Extra the best places (to reduce production costs) are also found to install the PSS. Static Var Compensator (SVC) provides fast performing dynamic reactive compensation for voltage support during possibility events which would otherwise depress the voltage for a significant period of time [12],[13]. In this paper the designing of output feedback controller for PSS and SVC based on GA and PSO in order to damp the Low Frequency Oscillations (LFO) has been done. A 4 machines system has been modeled for studying LFO condition. Finally the performance of both compensators by using two ordinary algorithms was compared.

II. MODEL OF SVC AND PSS

SVC is a typical shunt-connected reactive power compensator that is developed with reactors and capacitors, and controlled by thyristor valves are paralleled by a determinative capacitor bank. In Fig. 1 a schematic model of Control-SVC has been shown.

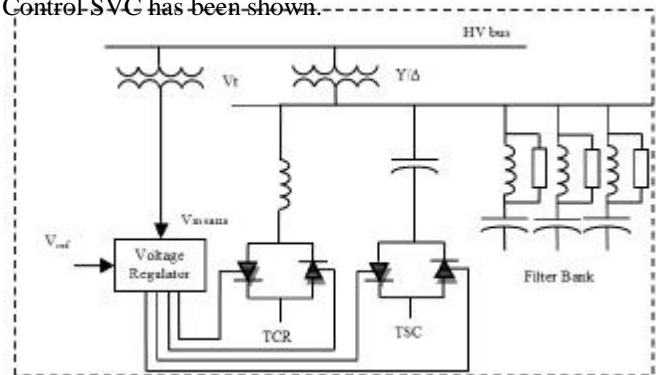

Fig.1. SVC schematic model

The initial purpose of an SVC control system is producing the fire signals to the thyristor valves for the phase angle control; the reactor in the same state (that is obtained an unbroken control on with a cycle by cycle basis for output of reactive power) produces the desired effect on the transmission system. When the thyristors in the valve have been fully conducting, the reactor used up more than the reactive power generated in the definitive capacitor bank and the output of the compensator is inductive. When the thyristors are blocked, there is no current in the reactor and the output of the compensator all of the reactive power generated in the capacitor bank.

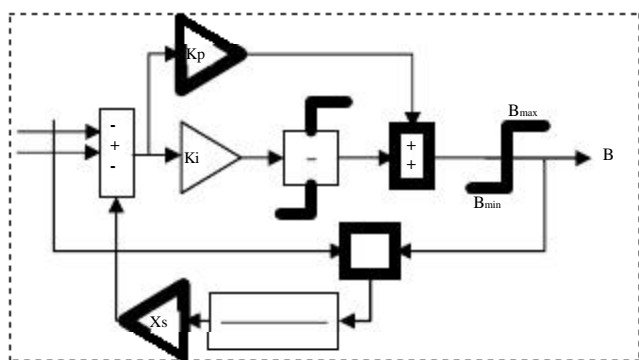

Fig.2. SVC Control System Overview

The power system stabilizer (PSS) is a supplementary control system applied in many cases as a part of excitation control system. The basic function of PSS is applying a signal to the excitation system, creating electrical torques to the rotor in phase with speed variation which damp out power oscillations. In such times, the conventional lead-lag power system stabilizer is greatly used by the power system utility. Other kinds of PSS like proportional-integral power system stabilizer (PI-PSS) and proportional-integral-derivative power system stabilizer (PIDPSS) has also been proposed. Fig.3. shows the block diagram of the power system stabilizer.

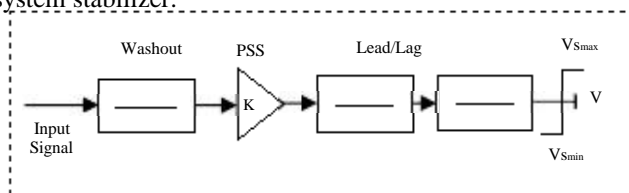

Fig.3. Power System Stabilizer

III. INTELLIGENT PARAMETER ESTIMATION BASED ON GENETIC AND PARTICLE SWARM OPTIMIZATION (PSO) ALGORITHM

There are many different ways to adjust control parameters. Genetic Algorithm (GA) and Particle Swarms Optimization (PSO) are used in this article. The flowchart of GA is shown in fig.4. Particle Swarms Optimization (PSO) is a robust stochastic optimization technique based on the movement and intelligence of swarms. PSO enforces the concept of social interaction to problem solving. The PSO algorithm commences with random initialization of velocity and population. The searching for the optimum solution resumptions unless one of the stopping criteria arrives. The stopping criteria can consist of below occasions:

1. Definitive maximum iterations are arrived.
2. There is no further improvement in the optimal solution.

The flowchart of PSO is shown in fig.5.

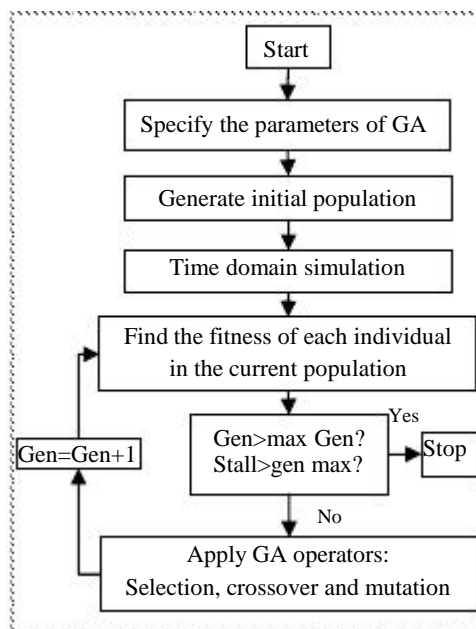

Fig.4. Flowchart of the GAs procedure

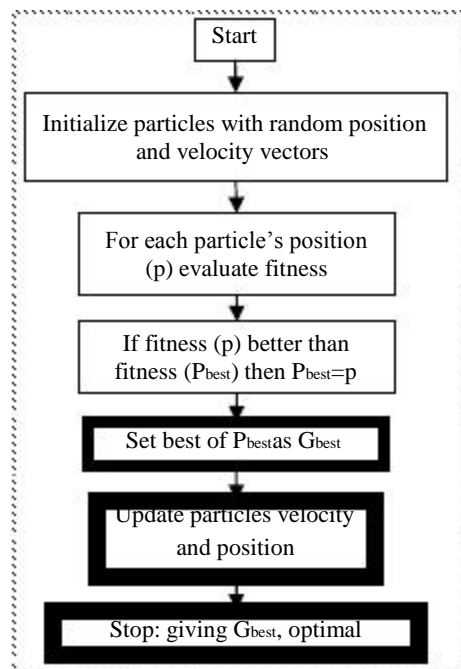

Fig.5. Flowchart of the PSO algorithm procedure

In this paper, the genetic and PSO algorithm are selected to tune K_p and K_i parameters in SVC and K , $T1$ and $T2$ in PSS. After some trials and errors because of the eliminating importance, the errors in short time, and also for decreasing steady state errors, the objective function is presented as below:

$$Mo = | \max(\Delta) - 1 | \tag{1}$$

$$p = | \text{numel}(\Delta) - 1 | \tag{2}$$

yf=1;

while (p) > 0.98yf && (p) < 1.02yf

p=p-1;

end

$$T_s = \frac{tout(p + 1) + tout(p)}{2} \quad (3)$$

$$Fitness = (Mo \cdot \frac{10000}{9})^2 + (T_s)^2 \quad (4)$$

IV. RESULTS AND SIMULINK OF MODEL MATLAB

A four machines system has been used in order to study low frequency oscillation (LFO). The single line diagram of two area power system is shown in Fig.6. This system consists of two areas linked together by two transmission lines. In each area there are two generators which are placed at buses 1 and 6 in area 1 and at buses 5 and 9 in area 2. The loads are at

bus 2 in area 1 and at bus 8 in area 2 and at bus 3 in center of system. In this system, gradually adding loads to B2, B3 and B8 LFO create condition is provided. These oscillations were small at first and with no compensation, they turned into larger oscillations and finally the system became unstable. PSS and SVC were used for compensation. To less production costs, PSS can be connected to a generator which produces more power. PSO and GA algorithm were used to determine optimal control parameters of SVC and PSS. Finally the performance of both compensator and two algorithms were compared.

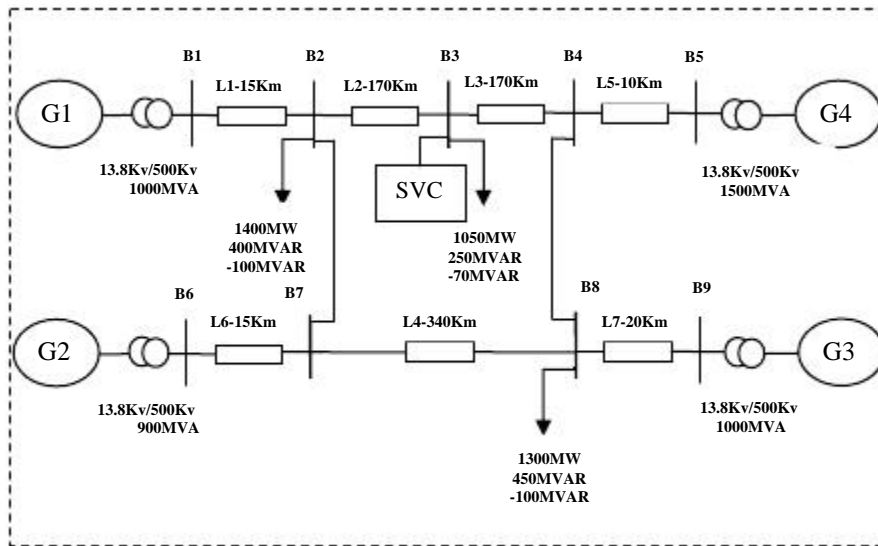

Fig.6. Schematic Model of Power System

In this system, the purpose of optimization by PSO and GA is decreasing the maximum overshoot (Mo) and setting time (Ts) according to equation 4. Tables I and II show the necessary information for these two algorithms, and Table III shows the imposed conditions for this paper.

TABLE I
GA's parameter setting

Population size	40
Crossover probability	0.9
Mutation probability	0.02
Maximum iteration	10

TABLE II
PSO's parameter setting

Population size	40
C2	2
C1	2
W	0.9
Iteration	10

TABLE III
Imposed conditions for SVC and PSS controllers

$0 < K_p < 5$	$0 < K_i < 20$	$0 < K < 10$
$0.01 < T_{in} < 2.5$	$0.1 < T_{id} < 5$	

In table IV system parameters have been shown.

TABLE IV
Generators parameters

Xd	1.305	Xl	0.18
Xd'	0.296	Td'	1.01
Xd''	0.252	Td''	0.053
Xq'	0.474	Tqo''	0.1
Xq''	0.243	H	3.7

In order to evaluate the performance of the proposed method, the algorithm applied to multi machine study case and the results are brought in this section. The results are presented in five cases. These cases are as follows:

First without PSS and SVC, second with PSS and without SVC optimization by GA, fifth without PSS and with SVC optimization by GA, third with PSS and without SVC optimization by PSO, forth without PSS and with

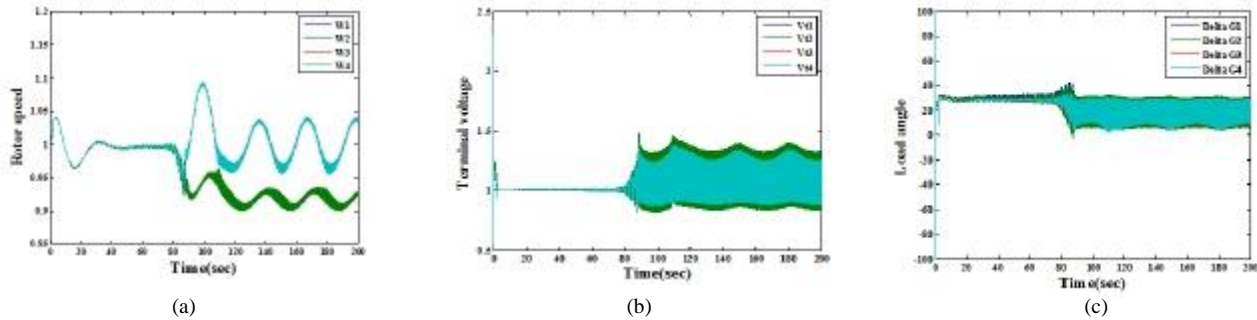

Fig.7. Generators rotor speed (a), terminal voltage (b) and Load angle (c) oscillations in LFO condition without compensating

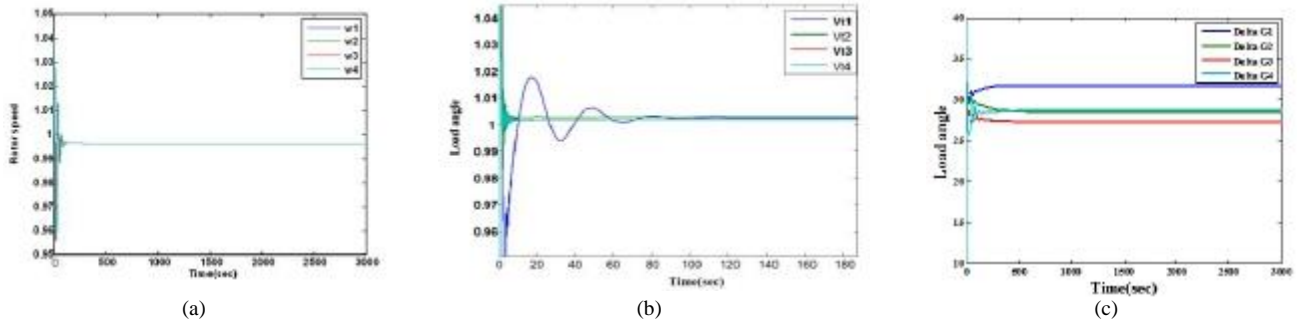

Fig.8. Generators rotor speed (a), terminal voltage (b) and Load angle (c) oscillations in LFO condition with PSS and without SVC optimization by GA

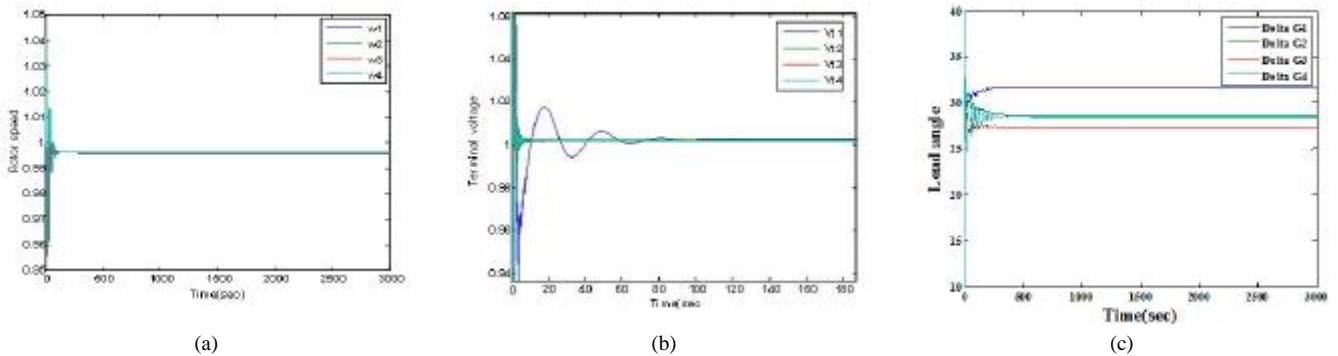

Fig.9. Generators rotor speed (a), terminal voltage (b) and Load angle (c) oscillations in LFO condition with PSS and without SVC optimization by PSO

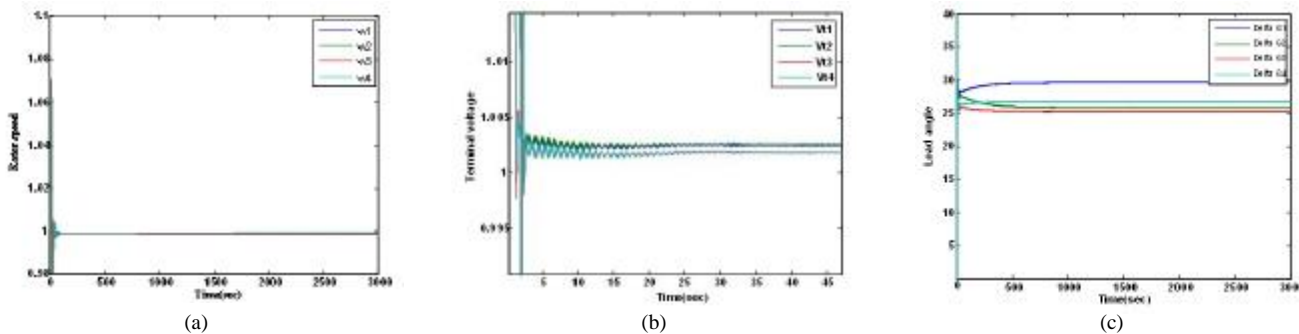

Fig.10. Generators rotor speed (a), terminal voltage (b) and Load angle (c) oscillations in LFO condition without PSS and with SVC optimization by GA

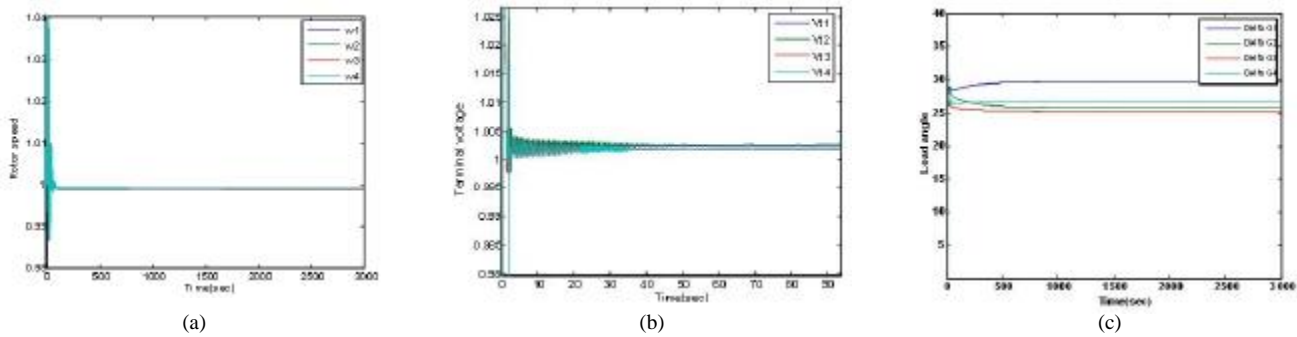

Fig.11. Generators rotor speed (a), terminal voltage (b) and Load angle (c) oscillations in LFO condition without PSS and with SVC optimization by PSO

TABLE V
SVC Compensator's Parameters in Bus 3

SVC	GA	PSO
Kp	3	0
Ki	4	1
Ts	12.10	8.63
Mo	0.0706	0.0478
ITR	10	10

TABLE VI
PSS Compensator's Parameters in Generator 4

PSS	GA	PSO
K	6.860148	7.1578
T1	0.649012	0.65973
T2	4.303648	2.8625
Ts	24.167	24.162
Mo	0.040050	0.040048
ITR	10	10

TABLE VII
PSS Compensator's Parameters in Generators 1 and 4

PSS	GA	PSO
K-1	3.364560	7.047890
T1-1	2.155818	0.337010
T2-1	2.767294	2.422342
K-4	1.300593	2.302241
T1-4	0.128260	2.000000
T2-4	3.960156	0.619966
Ts	26.2303	22.9472
Mo	0.0337	0.0272
ITR	10	10

Under tables V, VI and VII was observed that the PSO's performance was much better than GA. In this article at first on four-machine system, PSS was placed in machine 4 which produced the most power. Then the PSS was placed in both machines 1 and 4 that produced the most power in their area. According to table V and VI, maximum overshoot and setting time in two-PSS status compared with single-PSS status were decreased.

TABLE VIII
Profile Generator Output Using the Compensation with PSS and SVC

	Vt1(pu)	Vt2(pu)	Vt3(pu)	Vt4(pu)	1 (pu)	2 (pu)	3 (pu)	4 (pu)
PSS	1.002	1.003	1.002	1.002	0.9961	0.9961	0.9961	0.9961
SVC	1.002	1.003	1.002	1.002	0.9991	0.9991	0.9991	0.9991
	1	2	3	4	PG1(pu)	PG2(pu)	PG3(pu)	PG4(pu)
PSS	31.64	28.45	27.26	28.69	1.007	0.878	0.928	0.978
SVC	29.62	25.83	25.26	26.66	0.969	0.819	0.869	0.919
	VB2(pu)	VB3(pu)	VB4(pu)	VB7(pu)	VB8(pu)	-	-	-
PSS	1.076	1.083	1.054	1.076	1.054	-	-	-
SVC	1.065	1	1.046	1.065	1.046	-	-	-

V. CONCLUSION

When the LFO occurs to avoid unstable system, it is essential to use appropriate compensators. In this study, two compensators were used, SVC and PSS. Two algorithms-PSO and GA- were used to determine optimal parameters for compensating. The goal here was to reduce the maximum overshoot and setting time. In this paper it was characterized that placing the PSS in all of the four generators is not essential to damp LFO and for cost-effective purposes. Instead suggests placing PSS just in the generator that produces the most power. The advantage of SVC according to table V in comparison to the PSS is less setting time.

According to table VIII it was found that using the PSS generator stability improved and generators could produce more power, but SVC was more effective in reducing the bus voltage.

REFERENCES

- [1] Y.L. Abdel-Magid, and M.A. Abido, "Robust coordinated design of excitation and TCSC-based stabilizers using genetic algorithms," *International journal of Electric Power Systems Research*, vol. 69, pp. 129-41, May 2004.
- [2] Ancheng Xue, Pinghua An and Tianshu Bi "Global Governor-side Damping Controller for Low Frequency Oscillation of Power Systems Based on Partial State Feedback", *IEEE conference*, 2010.

- [3] P. Kundur, M. Klein, G. J. Rogers, and M. S. Zywno, "Application of Power System Stabilizers for Enhancement of Overall System Stability", IEEE Trans. PWRs, Vol. 4, No. 2, 1989, pp. 614-626.
- [4] M. Zarringhalami, S. M. Hakimi and M. Javadi, "Optimal Regulation of STATCOM Controllers and PSS Parameters Using Hybrid Particle Swarm Optimization", IEEE conference, 2010.
- [5] B. H. Li, Q. H. Wu, P. Y. Wang, X. X. Zhou, "Influence of the Transient Process of TCSC and MOV on Power System Stability", IEEE Trans. On Power Systems, VOL. 15, NO. 2, pp. 798-803, 2000.
- [6] Barkhordary, M.; Nabavi, S.M.H.; Motlagh, M.R.J.; Kazemi, A, "A Robust Feedback Linearization Controller Design for Thyristor Control Series Capacitor to Damp Electromechanical Oscillations", IEEE International Conference on Industrial Technology, 2006, pp. 2587 – 2592.
- [7] S. Panda, and N. Padhy, "Comparison of particle swarm optimization and Genetic Algorithm for FACTS-based controller design," *International journal of Applied Soft Computing*, pp. 1418-1427, 2008.
- [8] R. Jayabarathi, M.R Sindhu, N. Devarajan, and T.N.P. Nambiar, "Development of a Laboratory Model of Hybrid Static Var Compensator," IEEE conference, 2006.
- [9] Abolfazl Jalilvand and Mohammad Reza Safari Tirtashi, "Design of Output Feedback Controller for PSS and TCSC by GA to improve the Damping of Power System Oscillations", International Conference on Power and Energy (PECon2010), IEEE, 2010.
- [10] M. Zarringhalami, S. M. Hakimi and M. Javadi, "Optimal Regulation of STATCOM Controllers and PSS Parameters Using Hybrid Particle Swarm Optimization", IEEE, 2010.
- [11] LIU Zhijian, SHU Hongchun and Yu Jilai, "TCSC Applied to Suppress Inter-area Mode Oscillation Based on PMU and Fuzzy Logic Control", International Symposium on Intelligent Information Technology Application Workshops, IEEE, 2008.
- [12] E.Z. Zhou, "Application of static VAR compensators to increase power system damping", IEEE Trans. on Power Systems, Vol.8, No.2, PP May 1993.
- [13] Kitty Phorang & Prof. Dr. Yoshitomi Mizutani, "Damping improvement of oscillation in power system by fuzzy logic based SVC stabilizer", IEEE-2002.