

Pin Planning Methodology Guide

UG792 (v13.2) July 6, 2011



Xilinx is disclosing this user guide, manual, release note, and/or specification (the “Documentation”) to you solely for use in the development of designs to operate with Xilinx hardware devices. You may not reproduce, distribute, republish, download, display, post, or transmit the Documentation in any form or by any means including, but not limited to, electronic, mechanical, photocopying, recording, or otherwise, without the prior written consent of Xilinx. Xilinx expressly disclaims any liability arising out of your use of the Documentation. Xilinx reserves the right, at its sole discretion, to change the Documentation without notice at any time. Xilinx assumes no obligation to correct any errors contained in the Documentation, or to advise you of any corrections or updates. Xilinx expressly disclaims any liability in connection with technical support or assistance that may be provided to you in connection with the Information.

THE DOCUMENTATION IS DISCLOSED TO YOU “AS-IS” WITH NO WARRANTY OF ANY KIND. XILINX MAKES NO OTHER WARRANTIES, WHETHER EXPRESS, IMPLIED, OR STATUTORY, REGARDING THE DOCUMENTATION, INCLUDING ANY WARRANTIES OF MERCHANTABILITY, FITNESS FOR A PARTICULAR PURPOSE, OR NONINFRINGEMENT OF THIRD-PARTY RIGHTS. IN NO EVENT WILL XILINX BE LIABLE FOR ANY CONSEQUENTIAL, INDIRECT, EXEMPLARY, SPECIAL, OR INCIDENTAL DAMAGES, INCLUDING ANY LOSS OF DATA OR LOST PROFITS, ARISING FROM YOUR USE OF THE DOCUMENTATION.

© Copyright 2011 Xilinx Inc. All Rights Reserved. XILINX, the Xilinx logo, the Brand Window and other designated brands included herein are trademarks of Xilinx, Inc. All other trademarks are the property of their respective owners. The PowerPC name and logo are registered trademarks of IBM Corp., and used under license. All other trademarks are the property of their respective owners.

Revision History

The following table shows the revision history for this document.

Date	Version	Revision
03/01/2011	13.1	<ul style="list-style-type: none">• Initial version
07/06/2011	13.2	<ul style="list-style-type: none">• Added additional information to first paragraph of main chapter regarding use of RTL project in the PlanAhead software along with a synthesized netlist.• Added New Step 1: Select Device.• Changed Other IP to Connectivity IP.• Changed Noise Analysis to Noise Analysis (SSO and SSN).• Changed dual-purpose to multifunction.• Under Select Gigabit Transceivers, added information regarding placing GTs and avoiding use of hard IP.• Under Define Memory Interfaces, added information regarding generated constraints file.• Under I/O Interfaces, added information regarding creating interface groups in the PlanAhead software to manage additional interfaces.• Under I/O Standards, Attributes, added information regarding unplaced pins and differential pairs.• Under Clock Pins and Topology, added information regarding viewing package from top or bottom, and information on PCB design recommendations and pin planning guidelines, see the.• Under Place and Route, added information regarding locking down pins s and running DRCs before place and route.• Under Noise Analysis (SSO and SSN), added descriptions of SSO and SSN.• Under Noise Analysis (SSO and SSN), changed Weighted Average Simultaneous Switching Output (WASSO) to Simultaneous Switching Output (SSO).• Added reference to <i>PCB Design and Pin Planning Guide</i>.

Table of Contents

Revision History	3
Pin Planning Methodology	
Step 1. Select Device	8
Step 2. Select Configuration Mode	8
Step 3. Select Gigabit Transceivers	8
Step 4. Define Memory Interfaces	9
Step 5. Connectivity IP	9
Step 6. I/O Interfaces	9
Step 7. I/O Standards, Attributes	9
Step 8. Clock Pins and Topology	10
Step 9. Place and Route	10
Step 10. Noise Analysis (SSN and SSO)	11
Step 11. Board Level Considerations	11
Appendix A: Additional Resources	
Xilinx Resources	13
ISE Documentation	13
PlanAhead Documentation	13
Pin Planning Documentation	14

Pin Planning Methodology

The *Pin Planning Methodology Guide* recommends an Input/Output (I/O) pin planning methodology for Xilinx® devices using the PlanAhead™ software. While you can do pin planning at any step in the flow, this guide focuses on an RTL project with a synthesized netlist that allows more Design Rules Checks (DRCs) to run. If an RTL project and netlist is not available, the PlanAhead software allows an alternate limited pin planning-only flow.

The PlanAhead software and its I/O planning environment:

- Provide a design flow from Register Transfer Level (RTL) to bit stream.
- Allow you to:
 - Create, import, and configure the initial list of I/O ports early in the design flow.
 - Perform final verification of the pinout at the end of the design flow.
 - Group related ports into interfaces, then assign them to package pins.
 - Use fully automatic pin placement or semi-automated interactive modes for controlled I/O port assignment.
 - View the relationship of the physical package pins and banks with their corresponding I/O die pads.
 - Make intelligent decisions to optimize the connectivity between the PCB and the FPGA device.

The I/O pin planning methodology recommended by Xilinx includes the following steps:

- [Step 1. Select Device](#)
- [Step 2. Select Configuration Mode](#)
- [Step 3. Select Gigabit Transceivers](#)
- [Step 4. Define Memory Interfaces](#)
- [Step 5. Connectivity IP](#)
- [Step 6. I/O Interfaces](#)
- [Step 7. I/O Standards, Attributes](#)
- [Step 8. Clock Pins and Topology](#)
- [Step 9. Place and Route](#)
- [Step 10. Noise Analysis \(SSN and SSO\)](#)
- [Step 11. Board Level Considerations](#)

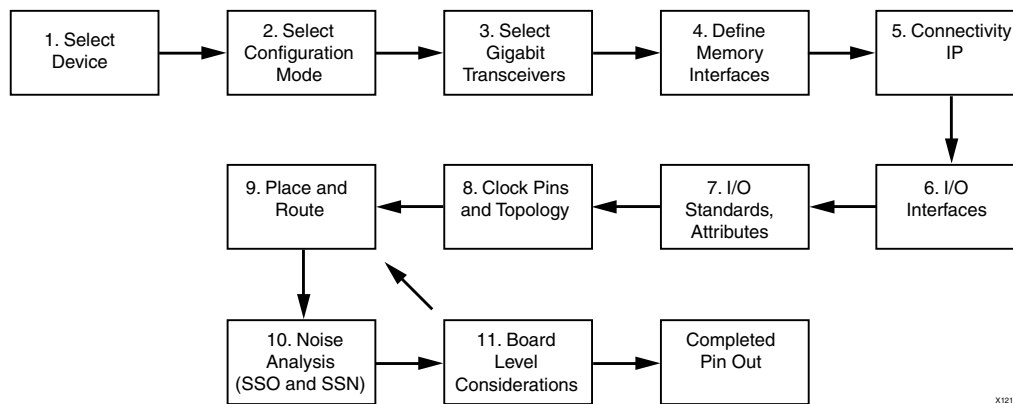

Figure 1-1: Xilinx Recommended Pin Planning Methodology

Step 1. Select Device

- Determine device size based on resource needs.
- Select package and possible alternative packages based on PCB requirements such as critical routes to memories.

Step 2. Select Configuration Mode

- Most configuration modes share some pins with User I/O. The number of shared pins typically:
 - Is *none* to *small* for serial modes.
 - Grows larger for parallel modes.
- Avoid signal contention to ensure successful configuration. If I/Os are used after configuration, they must be changed to tri-state during configuration.
- If the design allows, prohibit all multifunction pins to simplify the pinout.
- For more information, see the *Configuration User Guide* for each device family cited in [Appendix A, Additional Resources](#). The guides describe the dedicated and shared configuration pins for each mode. Check the user guide to see if certain configuration modes create additional pinout restrictions.

Step 3. Select Gigabit Transceivers

- Gigabit transceivers (GTs):
 - Have a set of dedicated pins.
 - Typically share clock pins with other GTs or I/O clock regions.
- Adjacent to the GTs, most device families list which user I/Os to avoid in order to achieve optimal signal integrity.
- Use the Clock Resources and Device views to help place GTs. Hard IP (such as PCIe) in a device can block a GT and should be avoided.
- For more information, see the *Gigabit Transceivers User Guide* for each device family cited in [Appendix A, Additional Resources](#).

Step 4. Define Memory Interfaces

- High speed memory interfaces have specific pinout requirements driven by clocking and skew needs.
- The Memory Interface Generator (MIG) software generates the required pinouts.
- Ensure that the generated constraints file is added to your project.

Step 5. Connectivity IP

- Some Intellectual Property (IP) such as Ethernet and the PCIe® software have specific pinout requirements.
- Use the CORE Generator™ software to incorporate any IP with external interfaces into the design.
- Like the Memory Interface Generator (MIG) software, the Xilinx CORE Generator software generates the required pinout constraints.

Step 6. I/O Interfaces

- Define any additional I/O interfaces.
- Create interface groups in the PlanAhead software to manage additional interfaces. This allows you to:
 - Simplify the ports list. You can group, place, manage and highlight interfaces as one object.
 - Give hierarchy to the ports list.

Step 7. I/O Standards, Attributes

- Define the I/O standards and other attributes.
- Place all unplaced pins so all pins are locked down. You can use the auto-placement feature to finish.
- Be conscious of differential pairs. In the Package view, you can enable and disable the Show Differential I/O Pairs option.
- Run a Design Rules Check (DRC) in the PlanAhead software to check I/O standard versus I/O banking restrictions.
- Some I/O standards can be combined within a single bank and some cannot. For information on banking rules, see the *SelectIO User Guides* cited in [Appendix A, Additional Resources](#).
- For information on the packaging and pinout specifications for specific device families, see the Packaging and Pinout guides available from the Xilinx support

website. See, for example, the *Virtex-6 FPGA Packaging and Pinout Specifications (UG365)* cited in [Appendix A, Additional Resources](#).

Step 8. Clock Pins and Topology

- Use the dedicated external clock pins on the FPGA device for best clock performance.
- Understand the following:
 - I/O versus fabric clocking resources.
 - Regional clock restrictions in the device family.
- Designs with fewer clocks than the number of global clock resources are usually simpler.
- For more complex clock structures, enter the clock tree and enough loads to run the early design through place and route for validation.
- Complex clock structures include designs with high clock counts that require either automatic or manual floor planning to utilize regional clocks
- To aid in clock planning, the PlanAhead software displays a graphical representation of the available clock resources for the target device.
- The package can be viewed from either the top or the bottom. Sometimes it is helpful to flip the part.
- The information on PCB design recommendations and pin planning guidelines, see the shows:
 - Connectivity
 - A 2D view of available clock resources
- For more information on Clocking Resources, see the *Clocking Resources User Guide* for each device family cited in [Appendix A, Additional Resources](#).

Step 9. Place and Route

- By this point, most if not all of the primary structures (I/O, IP, and Clocking) should be defined. The more primary structures that are defined and available, the more accurate are the associated DRCs.
- Lock down all pins.
- Run DRCs before place and route.
- Run the design through place and route to validate the pinout.
- Not all logic needs to be in place, only the primary structures that affect pinout.
- Fully implement the design in order to ensure a legal I/O pinout.
- Review the **ngdbuild** and **map** reports for I/O and clock-related messages.
- Only the place and route tools contain all sign-off DRCs on the final design and pinout.

Step 10. Noise Analysis (SSN and SSO)

Table 1-1: Noise Analysis Methods (SSN and SSO) Supported in the PlanAhead Software

Method	Description	Supported Devices
Simultaneous Switching Noise (SSN)	Based on relative pin locations, SSN determines pins with excessive noise. You can move those pins to another location within the bank, or to another bank.	<ul style="list-style-type: none"> Spartan®-6 Virtex®-6
Simultaneous Switching Output (SSO)	SSO calculates the maximum number of user I/O components that can be assigned within a bank. SSO does not take relative pin locations into account.	<ul style="list-style-type: none"> Spartan-3 Virtex-4 Virtex-5

- To improve results when a violation occurs:
 - Use I/O standards that have a lower noise impact for the failing group.
 - Reduce noise by changing to a:
 - Lower drive strength.
 - Parallel-terminated DCI I/O standard.
 - Lower class of driver.
 Example: Changing the SSTL Class II to an SSTL Class I.
 - Relocate the pin within the bank to an alternate location that is a greater distance from other noisy pins.
 - Spread the failing pins across multiple banks. This reduces the number of aggressive outputs on the power system of one bank.
 - Spread the failing group across multiple synchronous phases.
- If the design changes:
 - Rerun [Step 9. Place and Route](#).
 - Return to [Step 10. Noise Analysis \(SSN and SSO\)](#).
- For more information, see the *PlanAhead User Guide (UG632)* cited in [Appendix A, Additional Resources](#).

Step 11. Board Level Considerations

- For board-level validation, perform signal integrity analysis using IBIS (Input/Output Buffer Information Specification) or HSPICE models.
- To optimize the pinout within the context of the entire board, import the FPGA pinout into third party products such as:
 - Cadence Allegro FPGA System Planner*
 - Mentor Graphics I/O Designer
- If the pinout changes:
 - Rerun [Step 9. Place and Route](#).
 - Continue from that step on.

Additional Resources

Xilinx Resources

- *ISE® Design Suite: Installation and Licensing Guide (UG798):*
http://www.xilinx.com/support/documentation/sw_manuals/xilinx13_2/iil.pdf
- *ISE Design Suite 13: Release Notes Guide (UG631):*
http://www.xilinx.com/support/documentation/sw_manuals/xilinx13_2/irn.pdf
- **Xilinx® Documentation:**
<http://www.xilinx.com/support/documentation.htm>
- **Xilinx Glossary:**
http://www.xilinx.com/support/documentation/sw_manuals/glossary.pdf
- **Xilinx Support:** <http://www.xilinx.com/support.htm>
- **Xilinx Data Sheets:**
http://www.xilinx.com/support/documentation/data_sheets.htm

ISE Documentation

- **ISE Documents:**
http://www.xilinx.com/support/documentation/dt_ise13-2.htm
 - *Command Line Tools User Guide (UG628):*
http://www.xilinx.com/support/documentation/sw_manuals/xilinx13_2/devref.pdf
 - *Constraints Guide (UG625):*
http://www.xilinx.com/support/documentation/sw_manuals/xilinx13_2/cgd.pdf
 - *Xilinx Synthesis and Simulation Design Guide (UG626):*
http://www.xilinx.com/support/documentation/sw_manuals/xilinx13_2/sim.pdf
 - *XST User Guide for Virtex-4, Virtex-5, Spartan-3, and Newer CPLD Devices (UG627):*
http://www.xilinx.com/support/documentation/sw_manuals/xilinx13_2/xst.pdf
 - *XST User Guide for Virtex-6, Spartan-6, and 7 Series Devices (UG687):*
http://www.xilinx.com/support/documentation/sw_manuals/xilinx13_2/xst_v6s6.pdf

PlanAhead Documentation

- **PlanAhead Documentation:**
http://www.xilinx.com/support/documentation/dt_planahead_planahead13-2_userguides.htm

- *What's New in PlanAhead 13.2 Release (UG656)*:
http://www.xilinx.com/support/documentation/sw_manuals/xilinx13_2/Whats_New_PlanAhead.pdf
- **Methodology Guides**: http://www.xilinx.com/support_documentation
 - *Floorplanning Methodology Guide (UG633)*:
http://www.xilinx.com/support/documentation/sw_manuals/xilinx13_2/Floorplanning_Methodology_Guide.pdf
 - *Hierarchical Design Methodology Guide (UG748)*:
http://www.xilinx.com/support/documentation/sw_manuals/xilinx13_2/Hierarchical_Design_Methodology_Guide.pdf
 - *Pin Planning Methodology Guide (UG792)*:
http://www.xilinx.com/support/documentation/sw_manuals/xilinx13_2/ug792_pinplan.pdf
- *PlanAhead User Guide (UG632)*:
http://www.xilinx.com/support/documentation/sw_manuals/xilinx13_2/PlanAhead_UserGuide.pdf
- *PlanAhead Tcl Command Reference Guide (UG789)*:
http://www.xilinx.com/support/documentation/sw_manuals/xilinx13_2/ug789_tcl_commands.pdf
- **PlanAhead Tutorials**:
http://www.xilinx.com/support/documentation/dt_planahead_planahead13-2_tutorials.htm
 - *Design Analysis and Floorplanning (UG676)*:
http://www.xilinx.com/support/documentation/sw_manuals/xilinx13_2/PlanAhead_Tutorial_Design_Analysis_Floorplan.pdf
 - *Leveraging Design Preservation for Predictable Results (UG747)*:
http://www.xilinx.com/support/documentation/sw_manuals/xilinx13_2/PlanAhead_Tutorial_Design_Preservation.pdf

Pin Planning Documentation

- For information on I/O pin planning and flows in the PlanAhead software, see the *PlanAhead Software Tutorial - I/O Pin Planning (UG674)* at: http://www.xilinx.com/support/documentation/sw_manuals/xilinx13_2/PlanAhead_Tutorial_IO_Pin_Planning.pdf
- For information on the packaging and pinout specifications for specific device families, see the Packaging and Pinout guides available from the Xilinx support website. See, for example:
 - *Virtex-6 FPGA Packaging and Pinout Specifications (UG365)* at: http://www.xilinx.com/support/documentation/user_guides/ug365.pdf
- For information on banking rules, see the *SelectIO Resources User Guides* available from the Xilinx support website. See, for example:
 - *7 Series FPGAs SelectIO Resources User Guide (UG471)* at: http://www.xilinx.com/support/documentation/user_guides/ug471_7Series_SelectIO.pdf
- For information on PCB design recommendations and pin planning guidelines, see the *PCB Design and Pin Planning Guide* for each device family. See, for example:
 - *Spartan-6 FPGA PCB Design and Pin Planning Guide (UG393)* at: http://www.xilinx.com/support/documentation/user_guides/ug393.pdf
 - *7 Series FPGAs PCB Design and Pin Planning Guide (UG483)* at: http://www.xilinx.com/support/documentation/user_guides/ug483_7Series_PCB.pdf

- For information on PlanAhead functionality and commands, see "I/O Pin Planning" in the *PlanAhead User Guide (UG632)* at: http://www.xilinx.com/support/documentation/sw_manuals/xilinx13_2/PlanAhead_UserGuide.pdf
- For information on configuration mode, see the *Configuration User Guide* for each device family available from the Xilinx support website at: <http://www.xilinx.com/support/documentation>
- For information about Gigabit Transceivers, see the *Gigabit Transceivers User Guide* for each device family available from the Xilinx support website at: <http://www.xilinx.com/support/documentation>
- For more information on Clocking Resources, see the *Clocking Resources User Guide* for each device family available from the Xilinx support website at: <http://www.xilinx.com/support/documentation>
- For information on the following third party pin planning tools that support Xilinx FPGA pin planning at the board level, see:
 - *Cadence Allegro FPGA System Planner (FSP)* at: www.cadence.com
 - *Mentor Graphics I/O Designer* at: www.mentor.com

