

GO REGULATOR

Single Stage Pressure Regulators

Index

PR-1 Series	1	CPR-1 Series	19
PR-2 Series	3	CPR-5 Series	21
PR-5 Series	5	LG-1 Series	23
PR-7 Series	7	PR-50 Series	25
PR-7LF Series	9	PR-56 Series	27
PR-7ULF Series	11	PR-57 Series	29
PR-9 Series	13	PR-58 Series	31
PR-11 Series	15	PR-59 Series	33
SPR Series	17	Port Configurations	35



pressure regulators

GO Regulator

405 Centura Court • PO Box 4866 • Spartanburg, SC 29303

Phone (864) 574-7966 Fax (864) 574-5608

www.goreg.com • sales@goreg.com

GO REGULATOR

PR-1 Series

Adjustable Pressure Reducing Regulator



The PR-1 Series is a versatile pressure reducing regulator designed to fulfill a wide range of needs in instrumentation sample systems and other applications such as semiconductor processing gases. Many features of the PR-1 make it ideal for a wide range of applications controlling pressures at low to moderate flows in gas or liquid service. 316L body material is used to facilitate welded connections. Stainless steel caps and adjusting screws prevent atmospheric corrosion and maintain appearance. Enhanced internal body surface finish of better than 25 Ra plus electropolishing allows easier cleaning and potentially less particle contamination in the flow stream.

Five different seat materials, three alternate orifice sizes and seven pressure control ranges with stainless diaphragms offer the user a wide spectrum of capabilities for pressure control with inlet pressures up to 6000 psig and standard operating temperatures up to 500° F (260° C).

Features & Specifications

- Gas or liquid service
- 316L stainless steel, Inconel®, Teflon®, and Tefzel® (or optional main seat material choice) only in flow stream
- Electropolished 316L body with better than 25 Ra diaphragm cavity surface finish
- Stainless steel cap with SS adjusting screw
- Inlet pressures of up to 6000 psi
- Adjustable outlet pressure ranges of 0–10, 0–25, 0–50, 0–100, 0–250, 0–500 and 0–750 psig
- Operating temperatures of –40° F up to +500° F (–40° C up to +260° C)
- 20 micron filters
- Bubble-tight shutoff under most conditions
- Cv flow coefficients 0.025, 0.06, 0.20, and 0.50 (0.06 standard)

Options

- Wetted materials of construction: Monel®, Hastelloy®, and titanium
- Diaphragm attached poppet
- Special fittings
- Diaphragm assist spring for vacuum purging
- Panel mount (1 $\frac{3}{8}$ " mounting hole)
- Relief valves
- Special diaphragm assembly for water service
- SS inlet pressure gauges
- SS outlet pressure gauges
- Base-mounting brackets
- Captured vent
- Self-relieving

GO Regulator

405 Centura Court • PO Box 4866 • Spartanburg, SC 29303
Phone (864) 574-7966 Fax (864) 574-5608
www.goreg.com • sales@goreg.com

pressure regulators

PR-1 Series

How to Order

PR1 -

BODY MATERIAL

- 1 316L stainless steel
- 4 Monel®
- 6 Hastelloy® C

PORT CONFIGURATION

- A Standard
- For more port configurations see page 35.

PROCESS PORT TYPES (GAUGE PORT TYPES, IF SPECIFIED)

- 0 1/8" FNPT (1/8" FNPT gauge ports)
- 1 1/4" FNPT (1/4" FNPT gauge ports), standard
- 3 1/4" sch 80 pipe stub, 4" long (1/4" FNPT gauge ports)
- 4 3/8" FNPT (1/4" FNPT gauge ports)
- H 1/4" sch 160 pipe stub, 4" long (1/4" FNPT gauge ports)
- K 1/4" sch 40 pipe stub, 4" long (1/4" FNPT gauge ports)

SURFACE FINISH OF DIAPHRAGM CAVITY

- 1 < 25 Ra, standard

SEAT MATERIAL

- A Tefzel®
- B CF Teflon®
- C Polyimide, high temperature service (metal knob standard)
- H PCTFE (formerly Kel-F® 81)
- I High density Teflon®
- Q PEEK™

CAP ASSEMBLY

- 1 Standard, stainless steel
- 4 Panel mount, stainless steel
- 5 Captured vent, aluminum
- 8 Tamper-proof, stainless steel
- C Metal knob, panel mount
- G Metal knob
- H 1/4" NPT dome-loaded, stainless steel
- J Captured vent, panel mount, stainless steel

DIAPHRAGM FACING/BACKING MATERIAL

- 1 Teflon®/stainless steel
- 6 Tefzel® ring/stainless steel
- 8 Teflon®/Inconel®
- 0 Teflon®/Hastelloy® C
- J Tefzel® ring/Inconel®

DIAPHRAGM TYPE

- 1 Standard diaphragm
- 2 Diaphragm attached poppet (DAP)
- 3 Self-relieving
- 4 Vacuum assist spring, standard diaphragm

OUTLET RANGE

- C 0-10 psig
- D 0-25 psig
- E 0-50 psig
- G 0-100 psig
- I 0-250 psig
- J 0-500 psig
- W 0-750 psig

FLOW COEFFICIENT (Cv)

- 3 0.06, standard
- 5 0.2
- C 0.025
- H 0.5

Maximum Temperature & Operating Inlet Pressures

SEAT MATERIAL	MAXIMUM TEMPERATURE*	@	MAXIMUM OPERATING INLET PRESSURE
Tefzel®	150° F (66° C)	@	3600 psig (24.82 MPa)
High density Teflon®	150° F (66° C)	@	3600 psig (24.82 MPa)
PCTFE (formerly Kel-F® 81)	175° F (80° C)	@	6000 psig (41.37 MPa)
Polyimide	500° F (260° C)	@	3600 psig (24.82 MPa)
Polyimide	175° F (80° C)	@	6000 psig (41.37 MPa)
PEEK™	500° F (260° C)	@	3600 psig (24.82 MPa)
PEEK™	175° F (80° C)	@	6000 psig (41.37 MPa)

* Temperatures in excess of 175° F (80° C) require a metal knob or the tamper-proof option.

Outline and Mounting Dimensions

Panel mount option requires 1.390 (35.3mm) minimum diameter panel cut out. 0.150 maximum panel thickness.

Weight = 1.9 lbs (0.86 kg)

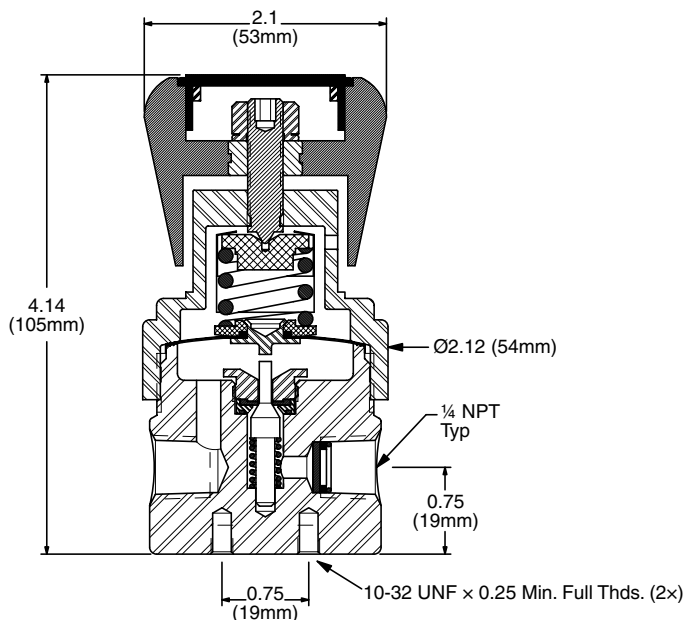

Inconel® and Monel® are registered trademarks of Special Metals Corporation.
 Teflon® and Tefzel® are registered trademarks of the DuPont Company.
 Hastelloy® is a registered trademark of Haynes International, Inc.
 Kel-F® is a registered trademark of 3M Company.
 PEEK™ is a trademark of Victrex PLC.

GO REGULATOR

PR-2 Series

Economy Brass Pressure Reducing Regulator



The PR-2 Series are compact, brass body regulators designed for maximum flexibility in many classes of instrumentation service. Specifically designed for gas applications, this regulator is capable of accepting high pressures directly from cylinders and other high pressure, non-corrosive systems. It is ideally suited for carrier gas pressure regulation, and is economical enough to use in low pressure air systems, such as instrument cabinet air purge service.

Features & Specifications

- Gas or liquid service
- Brass (alloy 360) construction
- Stainless steel diaphragm with Teflon® lining
- Stainless steel poppet
- Better than 25 Ra finish in diaphragm cavity
- 20 micron inlet filter
- Bubble-tight shutoff
- Outlet pressure ranges 0–10, 0–25, 0–50, 0–100, 0–250, 0–500 and 0–750 psig
- Operating temperatures -40° F to +175° F (-40° C to +80° C)
- Inlet and outlet connection ¼" FNPT
- Cv flow coefficients: 0.025, 0.06, 0.20, and 0.5 (0.06 standard)

Options

- ½" or ¾" FNPT connections
- Panel mount (requires 1¾" mounting hole)
- Extra ports
- Pressure gauges

pressure regulators

GO Regulator

405 Centura Court • PO Box 4866 • Spartanburg, SC 29303

Phone (864) 574-7966 Fax (864) 574-5608

www.goreg.com • sales@goreg.com

PR-2 Series

How to Order

PR2 -

BODY MATERIAL

- 2 Brass
- 8 Brass, chrome-plated

PORT CONFIGURATION

- A Standard
- For more port configurations, see page 35.

PROCESS PORT TYPES

(GAUGE PORT TYPES, IF SPECIFIED)

- 0 1/8" FNPT (1/8" FNPT gauge ports)
- 1 1/4" FNPT (1/4" FNPT gauge ports), standard
- 4 3/8" FNPT (1/4" FNPT gauge ports)

SURFACE FINISH OF DIAPHRAGM CAVITY

- 1 < 25 Ra, standard

SEAT MATERIAL

- A Tefzel®
- B CF Teflon®
- C Polyimide
- H PCTFE (formerly Kel-F® 81)
- I High density Teflon®
- Q PEEK™

FLOW COEFFICIENT (Cv)

- 3 0.06
- 5 0.2
- C 0.025
- H 0.5

OUTLET RANGE

- C 0-10 psig
- D 0-25 psig
- E 0-50 psig
- G 0-100 psig
- I 0-250 psig
- J 0-500 psig
- W 0-750 psig

OPTIONAL CAP FINISH

- 1 Chrome-plated
- 2 Electroless nickel-plated

CAP ASSEMBLY

- 1 Standard, aluminum
- 4 Panel mount, aluminum
- 5 Captured vent, aluminum
- 6 Captured vent, panel mount, aluminum
- 8 Tamper-proof, aluminum
- 9 Fine adjust, 1/2" panel mount, aluminum
- 0 Fine adjust, 1 3/8" panel mount, aluminum
- A Captured vent, tamper-proof, aluminum
- E Tamper-proof, panel mount, aluminum

DIAPHRAGM FACING/BACKING MATERIAL

- 1 Teflon®/stainless steel
- 2 Teflon®/Viton®
- 6 Tefzel® ring/stainless steel

DIAPHRAGM TYPE

- 1 Standard diaphragm
- 2 Diaphragm attached poppet
- 3 Self-relieving
- 4 Vacuum assist spring, standard diaphragm
- 5 Vacuum assist spring, diaphragm attached poppet
- 6 Vacuum assist spring, self-relieving
- 7 Liquid service

Maximum Temperature & Operating Inlet Pressures

SEAT MATERIAL	MAXIMUM TEMPERATURE	@	MAXIMUM OPERATING INLET PRESSURE
Tefzel®	150° F (66° C)	@	3600 psig (24.82 MPa)
High density Teflon®	150° F (66° C)	@	3600 psig (24.82 MPa)
PCTFE (formerly Kel-F® 81)	175° F (80° C)	@	3600 psig (24.82 MPa)
Polyimide	175° F (80° C)	@	3600 psig (24.82 MPa)
PEEK™	175° F (80° C)	@	3600 psig (24.82 MPa)

Outline and Mounting Dimensions

Panel mount option requires 1.390 (35.3mm) minimum diameter panel cut out. 0.150 maximum panel thickness.

Weight = 1.9 lbs (0.86 kg)

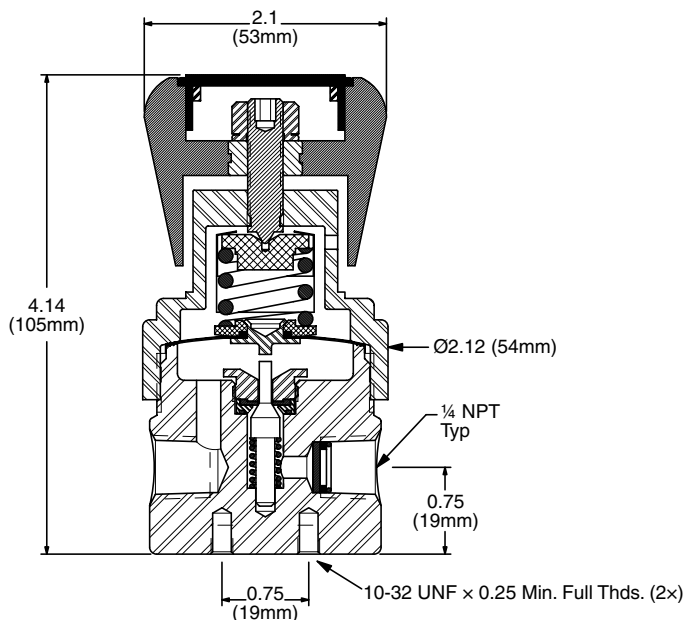

Teflon® and Tefzel® are registered trademarks of the DuPont Company.
 Kel-F® is a registered trademark of 3M Company.
 PEEK™ is a trademark of Victrex PLC.

GO REGULATOR

PR-5 Series

High Flow Adjustable Pressure Reducing Regulator



The PR-5 Series pressure regulator is designed for service at high flows with good sensitivity and regulation. While the design was originated for gas systems, this valve is perfectly suitable for liquid systems that are compatible with the materials of construction. The PR-5 also performs well with just a few liters per minute of flow.

This series is a variation of the time proven PR-1 Series which has been used for many applications in systems requiring stainless steel construction. The exact package size of the PR-1 has been retained making it convenient for the user to interchange these units if better control at high flow rates is required.

Features & Specifications

- High flow capability in compact size
- Minimum droop with large flow increases
- Bubble-tight shutoff
- Stainless steel cap & adjusting screw provided with stainless steel unit
- Materials of construction: stainless steel, brass, Teflon®, Viton®, Kalrez®, Buna N, or EPR
- 20 micron inlet filter
- Operating temperatures up to +400° F (+204° C)
- Ideal for line regulator applications
- Teflon®/Viton® diaphragm standard up to 50 psig
- Inlet pressure 300 psig
- Adjustable outlet ranges 0–10, 0–25, 0–50, 0–100, & 0–250 psig
- Cv flow coefficient 0.20

Options

- Panel mount (requires 1 $\frac{3}{8}$ " mounting hole)
- Extra ports
- Special welded connections
- Pressure gauges
- Captured vent

GO Regulator

405 Centura Court • PO Box 4866 • Spartanburg, SC 29303
Phone (864) 574-7966 Fax (864) 574-5608
www.goreg.com • sales@goreg.com

pressure regulators

PR-5 Series

How to Order

PR5 -

BODY MATERIAL

- 1 316L stainless steel
- 2 Brass
- 4 Monel®
- 6 Hastelloy® C

PORT CONFIGURATION

- A Standard

For more port configurations, see page 35.

PROCESS PORT TYPES

(GAUGE PORT TYPES, IF SPECIFIED)

- 0 1/8" FNPT (1/8" FNPT gauge ports)
- 1 1/4" FNPT (1/4" FNPT gauge ports)
- 2 1/4" tube stub, 2" long (1/4" FNTP gauge ports)
- 3 1/4" sch 80 pipe stub, 4" long (1/4" FNPT gauge ports)
- 4 3/8" FNPT (1/4" FNPT gauge ports)
- K 1/4" sch 40 pipe stub, 4" long (1/4" FNPT gauge ports)

SURFACE FINISH OF DIAPHRAGM CAVITY

- 1 < 25 Ra, standard
- 4 Filled

SEAT MATERIAL

- D Viton® (standard)
- E EPR
- J Buna N
- K Kalrez®

FLOW COEFFICIENT (Cv)

- 5 0.2

OUTLET RANGE

- C 0-10 psig
- D 0-25 psig
- E 0-50 psig
- G 0-100 psig
- I 0-250 psig

OPTIONAL CAP FINISH

- 1 Chrome-plated
- 2 Electroless nickel-plated

CAP ASSEMBLY

- 1 Standard
- 4 Panel mount
- 5 Captured vent, aluminum
- 8 Tamper-proof
- 9 Fine adjust, 1/2" panel mount, stainless steel
- A Captured vent, tamper-proof, aluminum
- H 1/4" NPT dome-loaded

DIAPHRAGM FACING/BACKING MATERIAL

- 1 Teflon®/stainless steel
- 2 Teflon®/Viton®
- 3 Teflon®/EPR
- 4 Teflon®/Buna N
- 6 Tefzel® ring/stainless steel
- 7 Viton®/stainless steel
- 8 Teflon®/Inconel®
- 0 Teflon®/Hastelloy® C
- C EPR/stainless steel
- D EPR/Viton®
- I Viton®/Inconel®

DIAPHRAGM TYPE

- 1 Standard diaphragm
- 3 Self-relieving
- 4 Vacuum assist spring, standard diaphragm
- 7 Liquid service

Maximum Temperature & Operating Inlet Pressures

SEAT MATERIAL	MAXIMUM TEMPERATURE*	@	MAXIMUM OPERATING INLET PRESSURE
Viton®	400° F (204° C)	@	300 psig (2.07 MPa)
EPR	150° F (66° C)	@	300 psig (2.07 MPa)
Buna N	150° F (66° C)	@	300 psig (2.07 MPa)
Kalrez®	400° F (204° C)	@	300 psig (2.07 MPa)

* Temperatures in excess of 175° F (80° C) require a metal knob or the tamper-proof option.

Outline and Mounting Dimensions

Weight = 1.9 lbs (0.86 kg)

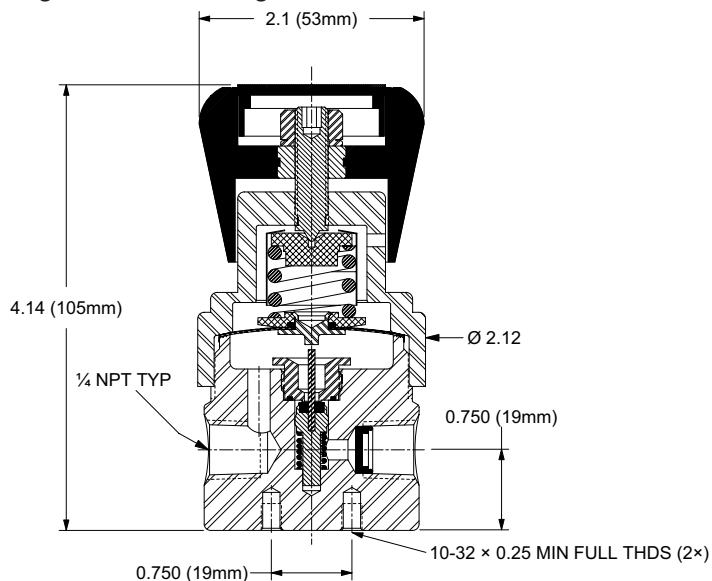

Monel® is a registered trademark of Special Metals Corporation.
 Teflon® is a registered trademark of the DuPont Company.
 Kalrez® and Viton® are registered trademarks of DuPont Dow Elastomers.
 Hastelloy® is a registered trademark of Haynes International, Inc.

GO REGULATOR

PR-7 Series

Ultra High Flow Adjustable Pressure Reducing Regulator



The PR-7 Series has been designed for those applications using high gas flow rates while still requiring a compact package. In addition, this unit will handle hydrogen flows up to 1000 liters per minute with none of the resonance problems typical with many regulators attempting such an application.

While designed for gas flow applications with low inlet pressures and low differential pressures, this valve has been constructed to withstand inlet pressures up to 3600 psig. With capability of holding outlet pressures closely with large changes of flow requirements, this valve is very suitable as a primary pressure supply to other pressure regulators located downstream.

Features & Specifications

- Minimal droop with large flow increased
- No resonance with large hydrogen flows
- Stainless steel diaphragm
- 316L stainless steel or brass construction (optional Hastelloy®, Monel®, or chrome-plated brass)
- T-handle adjusting assembly for easier adjustment in the 250 and 500 psig ranges
- Material of construction: brass, stainless steel, Viton®, Teflon®, PEEK™, or Kalrez®
- Stainless steel cap
- Cv flow coefficient = 1.1 (full Cv with ½" ported unit only)
- Operating temperatures up to +250° F (+121° C)
- Maximum inlet pressure of 3600 psig with PEEK™ seat
- Inlet/outlet connections: ¼", ⅜", or ½" FNPT
- Outlet pressure ranges of: 0–10, 0–25, 0–50, 0–100, 0–250 & 0–500 psig

Options

- Self-relieving
- Panel mount
- Captured vent

GO Regulator

405 Centura Court • PO Box 4866 • Spartanburg, SC 29303
Phone (864) 574-7966 Fax (864) 574-5608
www.goreg.com • sales@goreg.com

pressure regulators

PR-7 Series

How to Order

PR7 -

BODY MATERIAL

- 1 316L stainless steel
- 2 Brass
- 4 Monel®
- 6 Hastelloy® C
- 8 Brass, chrome-plated

PORT CONFIGURATION

- A Standard
- For more port configurations, see page 35.

PROCESS PORT TYPES (GAUGE PORT TYPES, IF SPECIFIED)

- 1 ¼" FNPT (¼" FNPT gauge ports)
- 4 ⅜" FNPT (¼" FNPT gauge ports)
- 5 ½" FNPT (¼" FNPT gauge ports)
- J ½" Tri-clover (¼" FNPT gauge ports)
- L ¾" Tri-clover (¼" FNPT gauge ports)

SURFACE FINISH OF DIAPHRAGM CAVITY

- 1 < 25 Ra

SEAT MATERIAL

- D Viton®
- I Teflon®
- K Kalrez®
- Q PEEK™

FLOW COEFFICIENT (Cv)

- 8 1.1

CAP ASSEMBLY

- 1 Standard, stainless steel
- 2 T-handle, stainless steel
- 3 T-handle, panel mount, stainless steel
- 4 Panel mount, stainless steel
- 5 Captured vent, aluminum
- 6 Captured vent, panel mount, aluminum
- 7 Captured vent, stainless steel
- 8 Tamper-proof, stainless steel
- 9 Fine adjust, ½" panel mount, stainless steel
- 0 Fine adjust, 1⅜" panel mount, stainless steel
- C Captured vent, panel mount, stainless steel
- E Tamper-proof, panel mount, stainless steel
- H ¼" NPT dome-loaded, stainless steel

DIAPHRAGM MATERIAL

- 1 Teflon®/stainless steel
- 2 Teflon®/Viton®
- 5 Viton®/stainless steel
- 6 Tefzel® ring/stainless steel
- 7 Tefzel® ring/Hastelloy® C
- 8 Teflon®/Inconel®
- 0 Teflon®/Hastelloy® C

DIAPHRAGM TYPE

- 1 Non-self-relieving
- 3 Self-relieving

OUTLET RANGE

- C 0-10 psig
- D 0-25 psig
- E 0-50 psig
- G 0-100 psig
- I 0-250 psig
- J 0-500 psig
- R 0-150 psig
- S 0-1 psig

Maximum Temperature & Operating Inlet Pressures

Up to 100 psig Outlet Pressure

SEAT MATERIAL	MAXIMUM TEMPERATURE*	@	MAXIMUM OPERATING INLET PRESSURE
Teflon®	150° F (66° C)	@	1000 psig (6.90 MPa)
PEEK™	250° F (121° C)	@	3600 psig (24.82 MPa)
Viton®	250° F (121° C)	@	300 psig (2.07 MPa)
Kalrez®	250° F (121° C)	@	300 psig (2.07 MPa)

* Temperatures in excess of 175° F (80° C) require a metal knob or the tamper-proof option.

0-250 psig & 0-500 psig Outlet Pressure (T-handle or Tamper-proof)

SEAT MATERIAL	MAXIMUM TEMPERATURE	@	MAXIMUM OPERATING INLET PRESSURE
Teflon®	150° F (66° C)	@	1000 psig (6.90 MPa)
PEEK™	250° F (121° C)	@	3600 psig (24.82 MPa)

Hastelloy® is a registered trademark of Haynes International, Inc.
 Monel® is a registered trademark of Special Metals Corporation.
 Kalrez® and Viton® are registered trademarks of DuPont Dow Elastomers.
 Teflon® is a registered trademark of the DuPont Company.
 PEEK™ is a trademark of Victrex PLC.

Outline and Mounting Dimensions

Weight = 3.2 lbs (1.45kg)

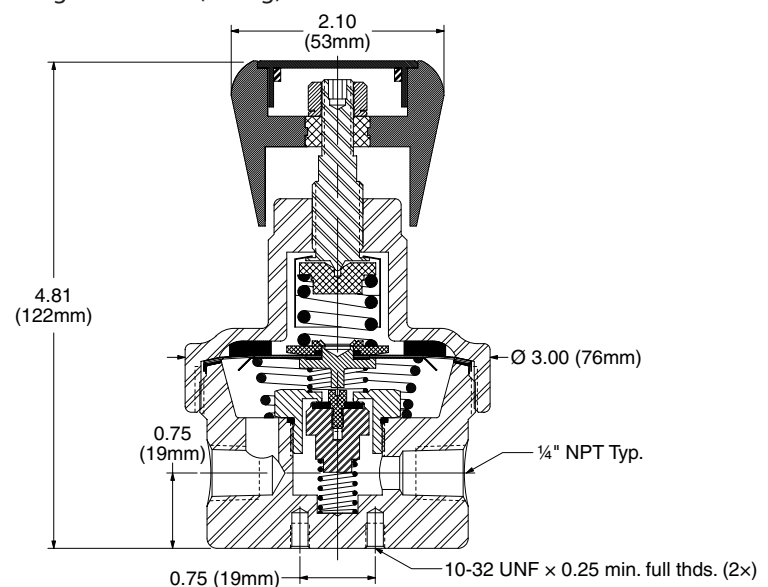

GO REGULATOR

PR-7LF Series

High Sensitivity Pressure Reducing Regulator



The PR-7LF Series pressure reducing regulator is designed to furnish precise low outlet pressure control to analytical instrumentation. With the combination of the large diaphragm sensing area of the PR-7 Series regulator and the low flow seat assembly of the PR-1 Series pressure regulator, pressure control down to 10 inches of water is easily obtainable.

The PR-7LF Series of regulators are available in a choice of stainless steel or brass construction; special alloys are available on special request.

Features & Specifications

- Sensitive pressure control
- Low pressure adjustability
- Stainless steel or brass construction (optional Monel® or Hastelloy® C construction)
- 20 micron inlet filter
- Optional special fittings including VCR®-compatible face seal (male or female)
- Inlet pressure to 3600 psig
- Adjustable outlet pressure ranges 0-6, 0-25, 0-50, 0-75, 0-125 & 0-250 psig
- Cv flow coefficients of 0.025; 0.06; 0.20; 0.50
- Teflon®/Viton® diaphragm standard up to 25 psig
- 316L stainless steel or brass, Inconel®, Tefzel® & Teflon® in the flow stream
- Operating temperatures -40° F to +250° F (-40° C to +121° C)
- Inlet and outlet connections ¼" FNPT standard

pressure regulators

GO Regulator

405 Centura Court • PO Box 4866 • Spartanburg, SC 29303
Phone (864) 574-7966 Fax (864) 574-5608
www.goreg.com • sales@goreg.com

PR-7LF Series

How to Order

PR7L -

BODY MATERIAL

- 1 316L stainless steel
- 2 Brass
- 4 Monel®
- 6 Hastelloy® C

PORT CONFIGURATION

- A Standard

For more port configurations, see page 35.

PROCESS PORT TYPES

(GAUGE PORT TYPES, IF SPECIFIED)

- 1 ¼" FNPT (¼" FNPT gauge ports)
- 4 ⅜" FNPT (¼" FNPT gauge ports)
- 5 ½" FNPT (¼" FNPT gauge ports)
- J ½" Tri-clover (¼" FNPT gauge ports)

SURFACE FINISH OF DIAPHRAGM CAVITY

- 1 < 25 Ra

SEAT MATERIAL

- A Tefzel®
- D Viton® (0.2 Cv only)
- H PCTFE (formerly Kel-F® 81)
- I High density Teflon®
- K Kalrez® (0.2 Cv only)

FLOW COEFFICIENT (Cv)

- 3 0.06
- 5 0.2
- C 0.025
- H 0.5

CAP ASSEMBLY

- 1 Standard, stainless steel
- 2 T-handle, stainless steel
- 3 T-handle, panel mount, stainless steel
- 4 Panel mount, stainless steel
- 5 Captured vent, aluminum
- 6 Captured vent, panel mount, aluminum
- 7 Captured vent, stainless steel
- 8 Tamper-proof, stainless steel
- 9 Fine adjust, ½" panel mount, stainless steel
- 0 Fine adjust, 1⅜" panel mount, stainless steel
- C Captured vent, panel mount, stainless steel
- E Tamper-proof, panel mount, stainless steel
- H ¼" NPT, dome-loaded

DIAPHRAGM FACING/BACKING MATERIAL

- 1 Teflon®/stainless steel
- 2 Teflon®/Viton®
- 5 Viton®/stainless steel
- 6 Tefzel® ring/stainless steel
- 7 Tefzel® ring/Hastelloy® C
- 8 Teflon®/Inconel®
- 0 Teflon®/Hastelloy® C

DIAPHRAGM TYPE

- 1 Standard diaphragm
- 2 Diaphragm-attached poppet
- 3 Self-relieving

OUTLET RANGE

- B 0-6 psig
- D 0-25 psig
- E 0-50 psig
- F 0-75 psig
- H 0-125 psig
- I 0-250 psig

Maximum Temperature & Operating Inlet Pressures

SEAT MATERIAL	MAXIMUM TEMPERATURE*	@	MAXIMUM OPERATING INLET PRESSURE
Teflon®	150° F (66° C)	@	3600 psig (24.82 MPa)
Tefzel®	150° F (66° C)	@	3600 psig (24.82 MPa)
PCTFE (formerly Kel-F® 81)	175° F (80° C)	@	3600 psig (24.82 MPa)
Viton®	250° F (121° C)	@	300 psig (2.07 MPa)
Kalrez®	250° F (121° C)	@	300 psig (2.07 MPa)

* Temperatures in excess of 175° F (80° C) require a metal knob or the tamper-proof option.

Outline and Mounting Dimensions

Weight = 3.2 lbs (1.45kg)

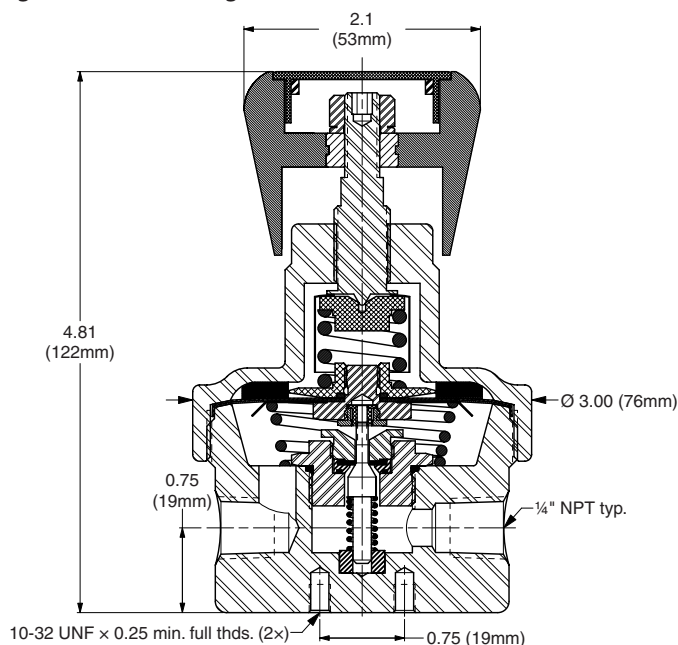

Inconel® and Monel® are registered trademarks of Special Metals Corporation.
 Hastelloy® is a registered trademark of Haynes International, Inc.
 VCR® is a registered trademark of Cajon Co.
 Teflon® and Tefzel® are registered trademarks of the DuPont Company.
 Kalrez® and Viton® are registered trademarks of DuPont Dow Elastomers.

GO REGULATOR

PR-7ULF Series

Pressure Reducing Regulator



The PR-7ULF Series pressure reducing regulator is designed to furnish ultra precise low outlet pressure control to analytical instrumentation. With the combination of the large diaphragm sensing area of the PR-7 Series regulator and a super low flow valve seat assembly, pressure control down to 1 inch of water at 2cc of flow is easily obtainable.

Features & Specifications

- Gas service
- 316L stainless steel or brass (alloy 360) construction
- Teflon® / Viton® diaphragm
- Electropolished body (316L) with better than 25 Ra finish in diaphragm cavity
- 20 micron inlet filter
- Bubble-tight shutoff
- Outlet pressure ranges are 0-6, 0-25, 0-50, and 0-100 psig
- Viton® seat
- 0.004 Cv flow coefficient

pressure regulators

GO Regulator

405 Centura Court • PO Box 4866 • Spartanburg, SC 29303
Phone (864) 574-7966 Fax (864) 574-5608
www.goreg.com • sales@goreg.com

PR-7ULF Series

How to Order

PR7U -

BODY MATERIAL

- 1 316L stainless steel
- 2 Brass

PORT CONFIGURATION

- A Standard

For more port configurations, see page 35

PROCESS PORT TYPES

(GAUGE PORT TYPES, IF SPECIFIED)

- 0 1/8" FNPT (1/8" FNPT gauge ports)
- 1 1/4" FNPT (1/4" FNPT gauge ports)

SURFACE FINISH OF DIAPHRAGM CAVITY

- 1 < 25 Ra

VENT VALVE

- 0 No
- 1 Yes

DIAPHRAGM TYPE

- 1 Standard

OUTPUT RANGE

- B 0-6 psig
- D 0-25 psig
- E 0-50 psig
- G 0-100 psig

CAP ASSEMBLY

- 4 Hand knob, 1 3/8" panel mount, stainless steel
- 5 Captured vent, aluminum
- 6 Captured vent, panel mount, aluminum
- 7 Captured vent, stainless steel
- 8 Tamper-proof, stainless steel
- 9 Fine adjust, 1/2" panel mount, stainless steel
- 0 Fine adjust, 1 3/8" panel mount, stainless steel
- Y Hand knob, stainless steel

DIAPHRAGM MATERIAL

- 1 Viton®
- 6 Tefzel® ring/stainless steel

Maximum Temperature & Operating Inlet Pressures

SEAT MATERIAL	MAXIMUM TEMPERATURE	@	MAXIMUM OPERATING INLET PRESSURE
Viton®	120° F (49° C)	@	250 psig (1.73 MPa)

Outline and Mounting Dimensions

Weight = 3.2 lbs (1.45kg)

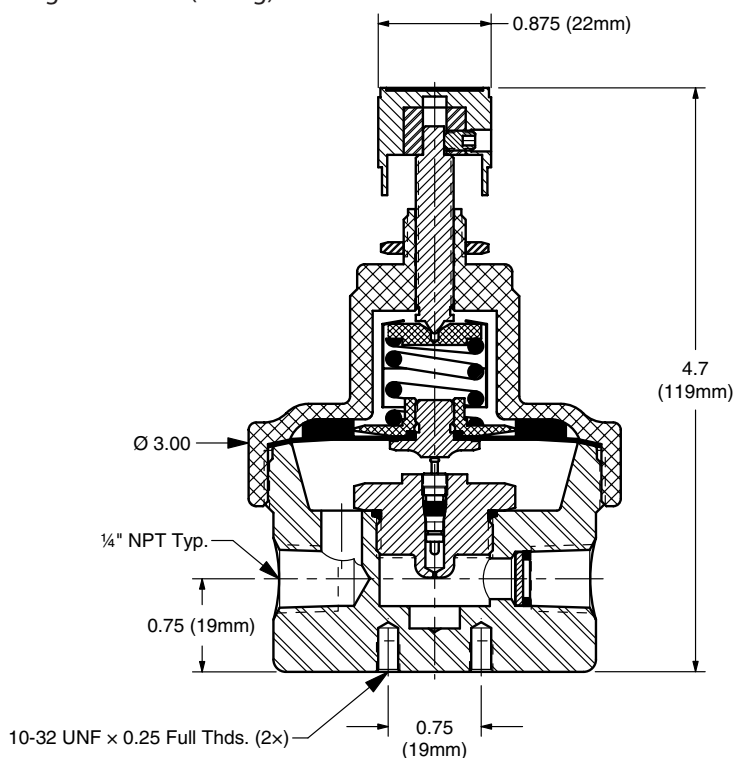

Teflon® and Tefzel® are registered trademarks of the DuPont Company.
Viton® is a registered trademark of DuPont Dow Elastomers.

GO REGULATOR

PR-9 Series

High Temperature Stainless Steel Pressure Regulator



The PR-9 Series high temperature pressure regulator is designed for the pressure control of gases and liquids up to 1000° F. All metal components in and out of the flow stream provide the user with extended reliability in rigorous high temperature ambient and process applications. This regulator can also be used in applications where no elastomers are allowed in the flow stream. The PR-9 is equipped with a metal-to-metal seat and will not provide bubble-tight shutoff. If shutoff is required, a high temperature shutoff valve must be placed upstream of this regulator

Features & Specifications

- 650° F (340° C) or 1000° F (540° C)
- All metal construction, no elastomers
- Gas or liquid service
- Inlet pressure 3000 psig at 650° F (343° C), 1500 psig at 1000° F (538° C)
- Adjustable outlet pressure ranges of 0-25, 0-50, 0-100 and 0-250 psig
- Stainless steel (316L or 347), Inconel®, tungsten carbide in flow stream
- Cv flow coefficient of 0.06 and 0.2
- Metal-to-metal seat seal
- Inlet and outlet connections ¼" FNPT
- Operating temperature -382° F (-200° C) to +1000° F (+540° C)

Options

- ⅜" FNPT connection and ¼" pipe stub
- Panel mount (requires 1⅜" mounting hole)
- Extra inlet and outlet ports
- Special welded connections

pressure regulators

GO Regulator

405 Centura Court • PO Box 4866 • Spartanburg, SC 29303
Phone (864) 574-7966 Fax (864) 574-5608
www.goreg.com • sales@goreg.com

PR-9 Series

How to Order

PR9 -

BODY MATERIAL

- 1 316L stainless steel (650° F)
- 9 347 stainless steel (1000° F)

PORT CONFIGURATION

- A Standard
- For more port configurations, see page 35

PROCESS PORT TYPES

(GAUGE PORT TYPES, IF SPECIFIED)

- 1 ¼" FNPT (¼" FNPT gauge ports)
- 2 ¼" tube stub, 2" long (¼" FNTP gauge ports)
- 3 ¼" sch 80 pipe stub, 4" long (¼" FNPT gauge ports)
- 4 ¾" FNPT (¼" FNPT gauge ports)
- D ¼" pipe socket (¼" FNPT gauge ports)
- 6 ½" tube stub, 2" long (¼" FNTP gauge ports)
- B ¼" internal VCR® (¼" tube gauge ports)
- C ¾" tube stub (¼" FNTP gauge ports)
- K ¼" sch 40 pipe stub, 4" long (¼" FNPT gauge ports)
- S ¼" MVCR (¼" tube gauge ports)

SURFACE FINISH OF DIAPHRAGM CAVITY

- 1 < 25 Ra

CAP ASSEMBLY

- 1 Standard, stainless steel
- 4 Panel mount, stainless steel
- N Contained bonnet, stainless steel

DIAPHRAGM LINER/BACKING

- G Tantalum

DIAPHRAGM TYPE

- 1 Standard

OUTLET RANGE

- C 0-10 psig
- D 0-25 psig
- E 0-50 psig
- G 0-100 psig
- I 0-250 psig

SEAT MATERIAL

- M 347 stainless steel

FLOW COEFFICIENT

- 3 0.06
- 5 0.2

Maximum Temperature & Operating Inlet Pressures

SEAT MATERIAL	MAXIMUM TEMPERATURE	@	MAXIMUM OPERATING INLET PRESSURE
316 stainless steel	650° F (343° C)	@	3000 psig (20.68 MPa)
347 stainless steel	1000° F (538° C)	@	1500 psig (10.34 MPa)

Outline and Mounting Dimensions

Weight = 2.1 lbs (0.95kg)

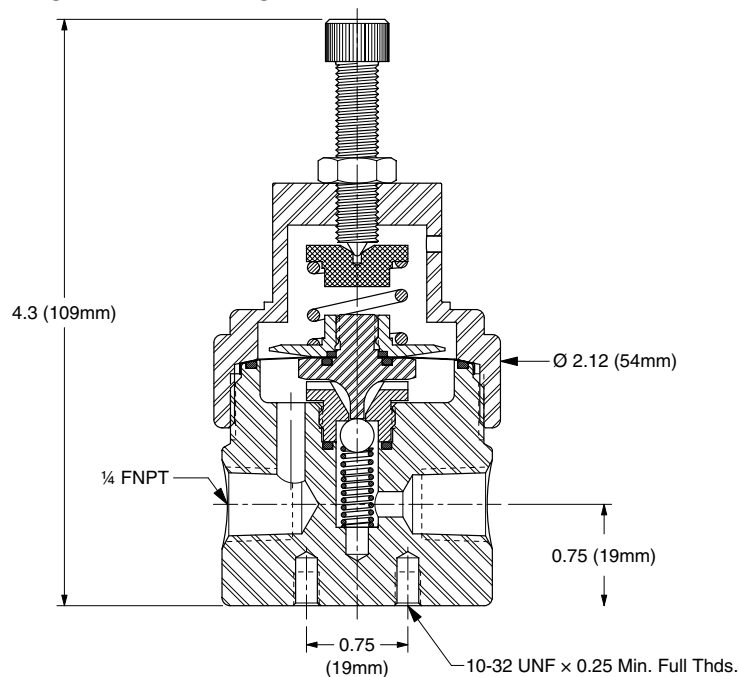

Inconel® is a registered trademark of Special Metals Corporation.

VCR® is a registered trademark of Cajon Co.

GO REGULATOR

PR-11 Series

Ultra Sensitive Pressure Control Regulator



This precision pressure regulator has been designed to allow the user complete flexibility in application. The instrument design engineer can now choose the optimum operating parameters he needs for a particular flow system.

Flow and pressure regulation can now be easily and economically accomplished in laboratory and process chromatographs, air pollution analyzers and other general process and laboratory instruments. The low internal volume and no trapped areas mean efficient operation and cleanliness in instrumentation with high sensitivity detectors. The standard stainless diaphragm prevents permeability of undesired contaminants into the flow stream.

This regulator offers greater pressure and flow stability for critical applications such as chemiluminescent type analyzers and is considered the ultimate in maximum stability with ambient temperature change. The PR-11 Series has truly been designed by experienced instrumentation engineers for use in that industry.

Features & Specifications

- Single stage precision regulation in a compact design package
- Bubble-tight shutoff
- Pressure gauge and relief valve ports optional
- Teflon® lined stainless steel or Viton® diaphragm standard
- Outlet pressure ranges 0-10, 0-25, 0-50, 0-100, 0-250 and 0-500 psig
- 40 micron inlet filter
- Suitable for gas or liquid service
- Panel mounting ½" diameter, standard
- ⅛" FNPT connections
- Inlet pressures to 3600 psig
- Cv flow coefficient of 0.025, 0.06, and 0.20
- Materials in contact with operating media are aluminum, 300 series stainless steel, Viton®, Teflon® and Inconel

Options

- ¼" FNPT connection
- Extra ports
- Pressure gauges
- Panel mount, (requires a 1⅜" mounting hole)

GO Regulator

405 Centura Court • PO Box 4866 • Spartanburg, SC 29303
Phone (864) 574-7966 Fax (864) 574-5608
www.goreg.com • sales@goreg.com

pressure regulators

PR-11 Series

How to Order

PR11 -

BODY MATERIAL

3 Aluminum

PORT CONFIGURATION

A Standard

For more port configurations, see page 35

PROCESS PORT TYPES

(GAUGE PORT TYPES, IF SPECIFIED)

0 1/8" FNPT (1/8" FNPT gauge ports)

1 1/4" FNPT (1/4" FNPT gauge ports)

SURFACE FINISH OF DIAPHRAGM CAVITY

1 < 25 Ra

SEAT MATERIAL

A Tefzel®

B CF Teflon®

C Polyimide

D Viton® (0.2 Cv only)

H PCTFE (formerly Kel-F® 81)

I High density Teflon®

Q PEEK™

CAP ASSEMBLY

1 Standard, stainless steel

2 Old style PR-10 topworks, aluminum

4 1 3/8" panel mount, aluminum

DIAPHRAGM FACING/BACKING MATERIAL

1 Teflon®/stainless steel

2 Teflon®/Viton®

DIAPHRAGM TYPE

1 Standard

2 Standard, NiSpan range spring

3 Self-relieving

4 Self-relieving, NiSpan range spring

OUTLET RANGE

C 0-10 psig

D 0-25 psig

E 0-50 psig

G 0-100 psig

I 0-250 psig

FLOW COEFFICIENT (Cv)

3 0.06

5 0.2

C 0.025

Maximum Temperature & Operating Inlet Pressures

SEAT MATERIAL	MAXIMUM TEMPERATURE	@	MAXIMUM OPERATING INLET PRESSURE
Viton®	225° F (107° C)	@	300 psig (2.07 MPa)
Tefzel®	150° F (66° C)	@	3600 psig (24.82 MPa)
High density Teflon®	150° F (66° C)	@	3600 psig (24.82 MPa)
PCTFE (formerly Kel-F® 81)	175° F (80° C)	@	3600 psig (24.82 MPa)
Polyimide	175° F (80° C)	@	3600 psig (24.82 MPa)
PEEK™	175° F (80° C)	@	3600 psig (24.82 MPa)

Outline and Mounting Dimensions

Weight = 0.7 lbs (0.31kg)

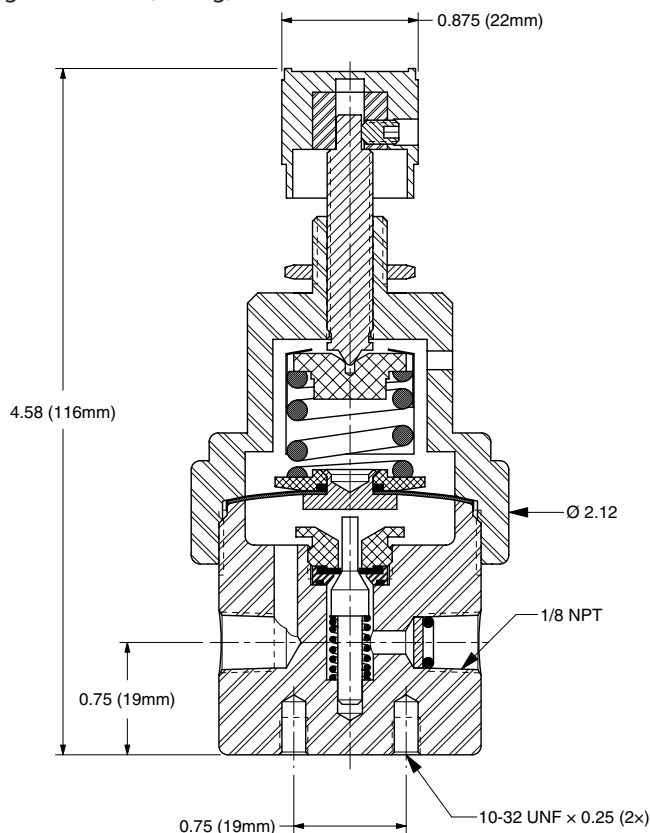

Teflon® and Tefzel® are registered trademarks of the DuPont Company.

Viton® is a registered trademark of DuPont Dow Elastomers.

Kel-F® is a registered trademark of 3M Company.

PEEK™ is a trademark of Victrex PLC.

GO REGULATOR

SPR Series

Subatmospheric Pressure Regulator



The SPR Series Subatmospheric Pressure Regulator is designed for the introduction of a low vapor pressure reactive or purge gas into a subatmospheric process. The large diameter diaphragm provides optimum sensitivity for subatmospheric or positive pressure control.

Standard features allow service in many varied applications including corrosive fluids and, with the optional features available, the user can tailor this regulator to applications ranging from semiconductor processing to analytical instrumentation.

Features & Specifications

- Subatmospheric or positive pressure control
- 20 micron inlet filter
- 316L stainless steel or brass construction
- Large stainless steel diaphragm with Teflon® lining for optimal pressure control
- Inlet pressure range from 15–160 psia (0–145 psig)
- Adjustable outlet pressure range of 1–30 psia (27.88 in. H₂O = 15.3 psig)
- Cv flow coefficient of 0.2
- Bubble-tight shutoff
- Operating temperatures -40° F to +250° F (-40° C to +121° C)
- Inlet/outlet connections 1/4" FNPT

Options

- High purity welded connections
- Class 100 assembly
- Extra ports
- Panel mount (requires 1 3/8" mounting hole)
- Pressure gauges

pressure regulators

GO Regulator

405 Centura Court • PO Box 4866 • Spartanburg, SC 29303
Phone (864) 574-7966 Fax (864) 574-5608
www.goreg.com • sales@goreg.com

SPR Series

How to Order

SPR -

BODY MATERIAL

- 1 316L stainless steel
- 2 Brass
- 4 Monel®
- 6 Hastelloy® C

PORT CONFIGURATION

- A Standard
- For more port configurations, see page 35

PROCESS PORT TYPES (GAUGE PORT TYPES, IF SPECIFIED)

- 1 ¼" FNPT (¼" FNPT gauge ports)
- 2 ¼" tube stub, 2" long, (¼" FNTP gauge ports)
- 4 ⅜" FNPT (¼" FNPT gauge ports)

SURFACE FINISH OF DIAPHRAGM CAVITY

- 1 < 25 Ra, standard

SEAT MATERIAL

- A Tefzel®
- D Viton®
- K Kalrez®

FLOW COEFFICIENT (Cv)

- 5 0.2
- C 0.025
- H 0.5

OUTLET RANGE

- A 0-30 psia

CAP ASSEMBLY

- 1 Standard, stainless steel
- 2 T-handle, stainless steel
- 3 T-handle, panel mount, stainless steel
- 4 Panel mount, stainless steel
- 5 Captured vent, aluminum
- 6 Captured vent, panel mount, aluminum
- 7 Captured vent, stainless steel
- 8 Tamper-proof, stainless steel
- 9 Fine adjust, ½" panel mount, stainless steel
- 0 Fine adjust, 1⅜" panel mount, stainless steel
- C Captured vent, panel mount, stainless steel
- E Tamper-proof, panel mount, stainless steel
- H ¼" NPT dome-loaded, stainless steel

DIAPHRAGM FACING/BACKING

- 1 Teflon®/stainless steel
- 2 Teflon®/Viton®
- 5 Viton®/stainless steel
- 6 Tefzel® ring/stainless steel
- 7 Tefzel® ring/Hastelloy® C
- 8 Teflon®/Inconel®
- 0 Teflon®/Hastelloy® C

DIAPHRAGM TYPE

- 1 Standard

Maximum Temperature & Operating Inlet Pressures

SEAT MATERIAL	MAXIMUM TEMPERATURE*	@	MAXIMUM OPERATING INLET PRESSURE
Tefzel®	150° F (66° C)	@	145 psig (1000 kPa)
Viton®	250° F (121° C)	@	145 psig (1000 kPa)
Kalrez®	250° F (121° C)	@	145 psig (1000 kPa)

* Temperatures in excess of 175° F (80° C) require a metal knob or the tamper-proof option.

Outline and Mounting Dimensions

Weight = 3.2 lbs (1.45kg)

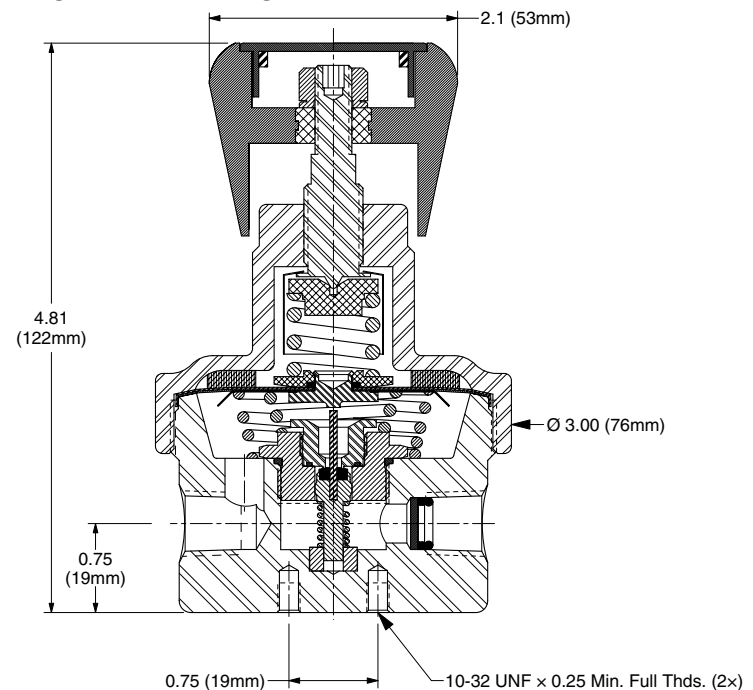

Teflon® and Tefzel® are registered trademarks of the DuPont Company.
 Inconel® and Monel® are registered trademarks of Special Metals Corporation.
 Hastelloy® is a registered trademark of Haynes International, Inc.
 Kalrez® and Viton® are registered trademarks of DuPont Dow Elastomers.

GO REGULATOR

CPR-1 Series

Compact Stainless Steel Pressure Reducing Regulator



The CPR-1 Series is a compact pressure regulator with most of the same internal design features employed in our time proven PR-1 Series. This regulator was designed to provide optimum performance as a "lecture bottle regulator" for pressure control in any application where a small size and low internal volume are required. The low internal volume allows more rapid purging in analytical instrumentation and semiconductor doping gas applications.

Features & Specifications

- Internal dead volume less than 4cc
 - Gas or liquid service
 - 316L stainless steel body
 - Stainless steel diaphragm
 - 40 micron inlet filter
 - Bubble-tight shutoff
 - Outlet pressure 0-10, 0-25, 0-50, 0-100, 0-250, 0-500* and 0-750*
 - Cv flow 0.025, 0.06, and 0.20
 - Operating temperatures -40° F to +500° F (-40° F to +260° C)
 - Inlet/outlet connections 1/8" FNPT
- * not with Viton®-backed diaphragm assembly*

Options

- Panel mount (requires 1 3/8" mounting hole)
- Special welded connections
- Pressure gauges
- Captured vent

pressure regulators

GO Regulator

405 Centura Court • PO Box 4866 • Spartanburg, SC 29303
Phone (864) 574-7966 Fax (864) 574-5608
www.goreg.com • sales@goreg.com

CPR-1 Series

How to Order

CPR1 -

BODY MATERIAL

- 1 316L stainless steel

PORT CONFIGURATION

- A Standard

For more port configurations, see page 35

PROCESS PORT TYPES

(GAUGE PORT TYPES, IF SPECIFIED)

- 0 1/8" FNPT (1/8" FNPT gauge ports), standard

SURFACE FINISH OF DIAPHRAGM CAVITY

- 1 < 25 Ra, standard

SEAT MATERIAL

- A Tefzel®
- C Polyimide
- H PCTFE (formerly Kel-F® 81)
- I High density Teflon®
- Q PEEK™

FLOW COEFFICIENT (Cv)

- 3 0.06
- 5 0.2
- C 0.025

OUTLET RANGE

- A 1–30 psig
- C 0–10 psig
- D 0–25 psig
- E 0–50 psig
- G 0–100 psig
- I 0–250 psig
- J 0–500 psig
- W 0–750 psig

CAP ASSEMBLY

- 1 Standard, aluminum
- 4 Panel mount, aluminum
- 5 Captured vent, aluminum
- 7 Captured vent, stainless steel
- 8 Tamper-proof, aluminum
- 9 Fine adjust, 1/2" panel mount, aluminum
- 0 Fine adjust, 1 3/8" panel mount, aluminum
- D Captured vent, tamper-proof, stainless steel

DIAPHRAGM FACING/BACKING/ O-RING MATERIAL

- 1 Tefzel® ring/stainless steel/Teflon®
- 2 Teflon®/Viton®/Viton®
- 3 Teflon®/Viton®/Teflon®
- 4 Teflon®/stainless steel/Viton®
- 7 Tefzel® ring/stainless steel/Viton®
- 8 Tefzel® ring/Inconel®/Teflon®
- H Tefzel® ring/Inconel®/Viton®

DIAPHRAGM TYPE

- 1 Standard, Nylon dia. slip ring (170° F maximum temperature)
- 2 Standard, Polyimide dia. slip ring (high temperature service)

Maximum Temperature & Operating Inlet Pressures

SEAT MATERIAL	MAXIMUM TEMPERATURE	@	MAXIMUM OPERATING INLET PRESSURE
Tefzel®	150° F (66° C)	@	3600 psig (24.82 MPa)
High density Teflon®	150° F (66° C)	@	3600 psig (24.82 MPa)
PCTFE (formerly Kel-F® 81)	175° F (80° C)	@	6000 psig (41.37 MPa)
Polyimide	500° F (260° C)	@	3600 psig (24.82 MPa)
Polyimide	175° F (80° C)	@	6000 psig (41.37 MPa)
PEEK™	500° F (260° C)	@	3600 psig (24.82 MPa)
PEEK™	175° F (80° C)	@	6000 psig (41.37 MPa)

Outline and Mounting Dimensions

Weight = 1.1 lbs (0.50kg)

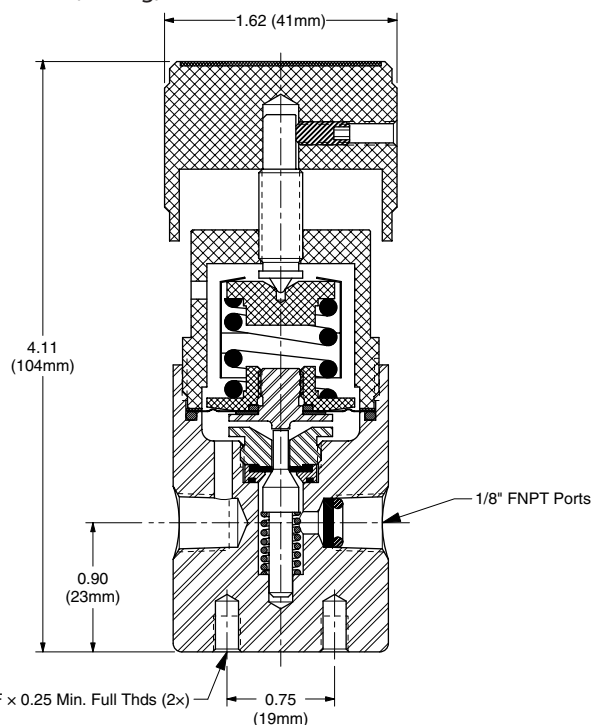

Viton® is a registered trademark of DuPont Dow Elastomers.

Teflon® and Tefzel® are registered trademarks of the DuPont Company.

Kel-F® is a registered trademark of 3M Company.

PEEK™ is a trademark of Victrex PLC.

Inconel® is a registered trademark of Special Metals Corporation.

GO REGULATOR

CPR-5 Series

Compact Stainless Steel Pressure Regulator



The CPR-5 Series pressure control valve is designed for service at high flows with good sensitivity and regulation utilizing a small footprint. While the design was originated for gas systems, this valve is perfectly suitable for liquid systems that are compatible with the materials of construction. Also of interest is the fact that while being able to perform with moderately high flows, this valve also provides very good performance in flow ranges of only a few liters a minute.

This series is a variation of the time proven CPR-1 Series which has been used for many applications in systems requiring stainless steel construction. The exact package size of the CPR-1 has been retained making it convenient for the user to interchange these units if better control at higher flows is required.

Features & Specifications

- Gas or liquid service
- 316L stainless steel construction
- Teflon®/stainless steel diaphragm up to 250 psig
- Teflon®/Viton® diaphragm up to 50 psig
- Electropolished body with better than 25 Ra finish in diaphragm
- 40 micron inlet filter
- Bubble-tight shutoff
- Outlet pressure ranges are 0–10, 0–25, 0–50, 0–100 and 0–250 psig
- Cv flow coefficient 0.2

pressure regulators

GO Regulator

405 Centura Court • PO Box 4866 • Spartanburg, SC 29303
Phone (864) 574-7966 Fax (864) 574-5608
www.goreg.com • sales@goreg.com

CPR-5 Series

How to Order

CPR5 -

BODY MATERIAL

- 1 316L stainless steel

PORT CONFIGURATION

- A Standard

For more port configurations, see page 35.

PROCESS PORT TYPES

(GAUGE PORT TYPES, IF SPECIFIED)

- 0 1/8" FNPT (1/8" FNPT gauge ports)
- 2 1/4" tube stub, 2" long (1/4" FNTP gauge ports)
- G 6mm tube stub, 2" long (6mm FNTP gauge ports)

SURFACE FINISH OF DIAPHRAGM CAVITY

- 1 < 25 Ra

SEAT MATERIAL

- D Viton®
- E EPR
- J Buna N
- K Kalrez®

FLOW COEFFICIENT (Cv)

- 5 0.2

CAP ASSEMBLY

- 1 Standard, aluminum
- 4 Panel mount, aluminum
- 5 Captured vent, aluminum
- 7 Captured vent, stainless steel
- 8 Tamper-proof, aluminum
- 9 Fine adjust, 1/2" panel mount, aluminum
- 0 Fine adjust, 1 3/8" panel mount, aluminum

DIAPHRAGM FACING/BACKING/ O-RING MATERIAL

- 1 Tefzel® ring/stainless steel/Teflon®
- 2 Teflon®/Viton®/Viton®
- 7 Tefzel® ring/stainless steel/Viton®

DIAPHRAGM TYPE

- 1 Standard, Nylon dia. slip ring (170° F maximum temperature)
- 2 Standard, Polyimide dia. slip ring (high temperature service)

OUTLET RANGE

- C 0-10 psig
- D 0-25 psig
- E 0-50 psig
- G 0-100 psig
- I 0-250 psig

Maximum Temperature & Operating Inlet Pressures

SEAT MATERIAL	MAXIMUM TEMPERATURE	@	MAXIMUM OPERATING INLET PRESSURE
Viton®	400° F (204° C)	@	300 psig (2.07 MPa)
EPR	150° F (66° C)	@	300 psig (2.07 MPa)
Buna N	150° F (66° C)	@	300 psig (2.07 MPa)
Kalrez®	400° F (204° C)	@	300 psig (2.07 MPa)

Outline and Mounting Dimensions

Weight = 1.1 lbs (0.50kg)

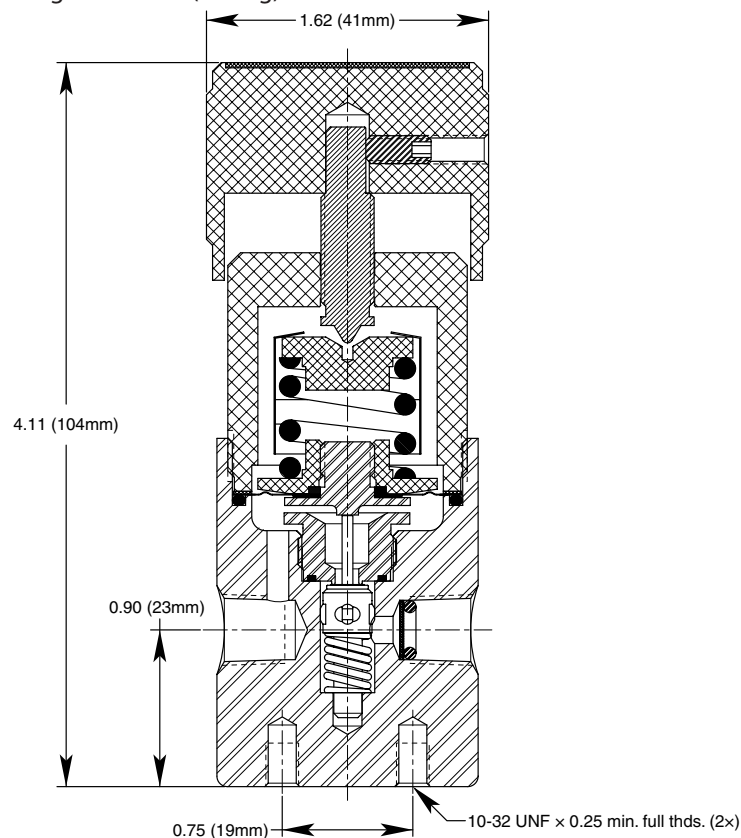

Teflon® and Tefzel® are registered trademarks of the DuPont Company.
Kalrez® and Viton® are registered trademarks of DuPont Dow Elastomers.

GO REGULATOR

LG-1 Series

Ultra Miniature Pressure Regulator



The LG-1 is an ultra-miniature pressure regulator that has many of the same features found in the time-tested design of the CPR-1 & PR-1 Series pressure regulators. Designed for surface, panel or manifold mounting, the LG-1 offers the utmost in versatility to the systems designer. It's low internal volume of less than 2.7cc makes the LG-1 the perfect choice for systems that require rapid purge cycles. Standard features permit using this regulator in a wide variety of services, including corrosive fluids. The LG-1 can be tailored to virtually any application by utilizing the optional features. All of this is attainable while achieving as low as 0.2% accuracy during supply pressure fluctuations. This regulator is designed to allow the construction of compact and sophisticated analytical instrumentation where the optimum in pressure control is required and space is at a premium.

Features & Specifications

- Gas or liquid service
- 316L stainless steel construction
- Internal volume is less than 2.7cc
- Electropolished body with better than 25 Ra finish in diaphragm cavity
- 20 micron inlet filter
- Bubble-tight shutoff
- Outlet pressure ranges are 0-10, 0-25, 0-50, 0-100, 0-250 and 0-500 psig
- Cv flow coefficient 0.025 or 0.06
- Option: surface mount (for manifolds)

pressure regulators

GO Regulator

405 Centura Court • PO Box 4866 • Spartanburg, SC 29303
Phone (864) 574-7966 Fax (864) 574-5608
www.goreg.com • sales@goreg.com

LG-1 Series

How to Order

LG1 -

BODY MATERIAL

- 1 316L stainless steel
- 2 Brass
- 3 Aluminum
- 4 Monel®

PORT CONFIGURATION

- A Standard

For more port configurations, see page 35.

PORT TYPE

- 0 1/8" FNPT (all ports)
- 1 Surface mount (consult factory for configurations)
- A 1/16" FNPT (all ports)
- B 1/8" FNPT inlets; 1/16" FNPT outlets

SURFACE FINISH OF DIAPHRAGM CAVITY

- 1 < 25 Ra

SEAT MATERIAL

- A Tefzel®
- C Polyimide
- H PCTFE (formerly Kel-F® 81)
- I High density Teflon®
- Q PEEK™

FLOW COEFFICIENT (Cv)

- 3 0.06
- C 0.025

CAP ASSEMBLY

- 1 Hand knob (0-100 psig maximum)
- 2 T-handle
- 3 T-handle, panel mount
- 4 Hand knob, panel mount (0-100 psig maximum)
- 8 Tamper-proof
- E Tamper-proof, panel mount

DIAPHRAGM FACING/BACKING/ O-RING MATERIAL

- 1 Tefzel® ring/stainless steel/Teflon®
- 7 Tefzel® ring/stainless steel/Viton®
- 8 Tefzel® ring/Inconel®/Teflon®
- H Tefzel® ring/Inconel®/Viton®

DIAPHRAGM TYPE

- 1 Standard, Nylon dia. slip ring (170° F maximum temperature)
- 2 Standard, Polyimide dia. slip ring (high temperature service)

OUTLET RANGE

- C 0-10 psig
- D 0-25 psig
- E 0-50 psig
- G 0-100 psig
- I 0-250 psig (requires T-handle or tamper-proof)
- J 0-500 psig (requires T-handle or tamper-proof)

Maximum Temperature & Operating Inlet Pressures

SEAT MATERIAL	MAXIMUM TEMPERATURE	@	MAXIMUM OPERATING INLET PRESSURE
Tefzel®	150° F (66° C)	@	3600 psig (24.82 MPa)
High density Teflon®	150° F (66° C)	@	3600 psig (24.82 MPa)
PCTFE (formerly Kel-F® 81)	175° F (80° C)	@	6000 psig (41.37 MPa)
Polyimide	500° F (260° C)	@	3600 psig (24.82 MPa)
Polyimide	175° F (80° C)	@	6000 psig (41.37 MPa)
PEEK™	500° F (260° C)	@	3600 psig (24.82 MPa)
PEEK™	175° F (80° C)	@	6000 psig (41.37 MPa)

Outline and Mounting Dimensions

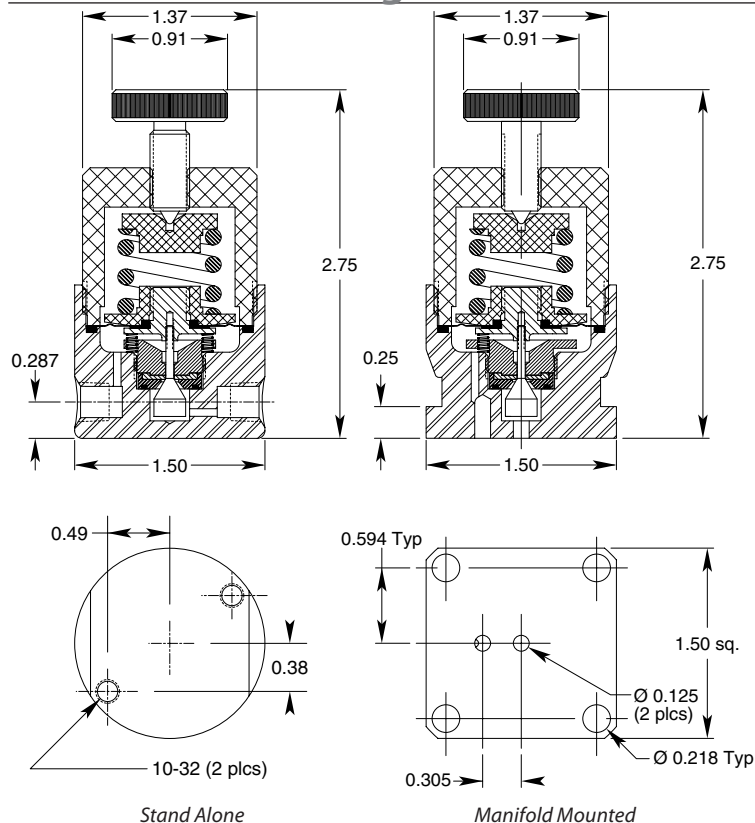

Inconel® and Monel® are registered trademarks of Special Metals Corporation.
 Teflon® and Tefzel® are registered trademarks of the DuPont Company.
 Kel-F® is a registered trademark of 3M Company.
 PEEK™ is a trademark of Victrex PLC.
 Viton® is a registered trademark of DuPont Dow Elastomers.

GO REGULATOR

PR-50 Series

Diaphragm-type High Pressure Regulator



The PR-50 Series pressure regulator is designed to meet the demands for outlet pressures up to 2000 psig while maintaining superior corrosion protection.

For reliability in operation, this precision regulator features a stainless steel body (optional brass) which provides maximum corrosion resistance and safety. The optional self-relieving feature provides an additional level in operational ease, as it allows for trapped downstream pressure to be safely vented to atmosphere through the bonnet.

To prolong regulator life, this unit is supplied with an integral inlet filter which protects the seat against any foreign contamination introduced by the upstream supply.

Features & Specifications

- Gas or liquid service
- Inlet pressure to 6000 psig
- Outlet pressure ranges 0–500, 0–1000, and 0–2000 psig
- 316L stainless steel or brass (alloy 360) construction
- 20 micron inlet filter
- Bubble-tight shutoff
- Diaphragm material standard stainless steel, nylon or Teflon®
- Flow coefficients (Cv) of 0.025, 0.06, and 0.20

Applications

- R & D systems
- Cylinder gas regulation
- Sampling systems
- Airline charging carts
- Pilot plants
- Offshore drillings

GO Regulator

405 Centura Court • PO Box 4866 • Spartanburg, SC 29303

Phone (864) 574-7966 Fax (864) 574-5608

www.goreg.com • sales@goreg.com

pressure regulators

PR-50 Series

How to Order

PR50 -

BODY MATERIAL

- 1 316L stainless steel
- 2 Brass
- 4 Monel®

PORT CONFIGURATION

- A Standard

For more port configurations, see page 35

PROCESS PORT TYPES

(GAUGE PORT TYPES, IF SPECIFIED)

- 1 ¼" FNPT (¼" FNPT gauge ports)
- 2 ¼" tube stub, 2" long (¼" FNTP gauge ports)
- 4 ⅜" FNPT (¼" FNPT gauge ports)
- 7 AN 10050-4 (¼" FNPT gauge ports)
- 8 SAE J514 (¼" FNPT gauge ports)
- 9 M/S 33649 (¼" FNPT gauge ports)
- K ¼" sch 40 pipe stub, 4" long (¼" FNPT gauge ports)

SURFACE FINISH OF DIAPHRAGM CAVITY

- 1 < 25 Ra, standard

SEAT MATERIAL

- A Tefzel®
- C Polyimide
- H PCTFE (formerly Kel-F® 81)
- I High density Teflon®
- Q PEEK™

FLOW COEFFICIENT (Cv)

- 3 0.06
- 5 0.2
- C 0.025

CAP ASSEMBLY

- 1 Standard, aluminum
- 4 Panel mount, aluminum
- 5 Captured vent, aluminum
- 6 Captured vent, panel mount, aluminum
- F Stainless steel
- V Captured vent, stainless steel
- W Panel mount, stainless steel

DIAPHRAGM FACING/BACKING MATERIAL

	Facing	Backing	O-rings	Actuator
1	St. steel	Nylon	Viton®	St. steel
6	Nylon	Nylon	Teflon®	St. steel
8	St. steel	Nylon	Viton®	St. steel
0	Nylon	Nylon	Teflon®	Monel®
H	—	Nylon	Viton®	St. steel

DIAPHRAGM TYPE

- 1 Non-self-relieving
- 3 Self-relieving

OUTLET RANGE

- J 0-500 psig
- K 0-1,000 psig
- L 0-2,000 psig

Maximum Temperature & Operating Inlet Pressures

Nylon Diaphragm Backing

SEAT MATERIAL	MAXIMUM TEMPERATURE*	@	MAXIMUM OPERATING INLET PRESSURE
Tefzel®	150° F (66° C)	@	3600 psig (24.82 MPa)
High density Teflon®	150° F (66° C)	@	3600 psig (24.82 MPa)
PCTFE (formerly Kel-F® 81)	175° F (80° C)	@	6000 psig (41.37 MPa)
Polyimide	175° F (80° C)	@	6000 psig (41.37 MPa)
PEEK™	175° F (80° C)	@	6000 psig (41.37 MPa)

Teflon® Diaphragm Backing

SEAT MATERIAL	MAXIMUM TEMPERATURE*	@	MAXIMUM OPERATING INLET PRESSURE
Tefzel®	150° F (66° C)	@	3600 psig (24.82 MPa)
High density Teflon®	150° F (66° C)	@	3600 psig (24.82 MPa)
PCTFE (formerly Kel-F® 81)	175° F (80° C)	@	6000 psig (41.37 MPa)
Polyimide	350° F (176° C)	@	6000 psig (41.37 MPa)
PEEK™	350° F (176° C)	@	6000 psig (41.37 MPa)

Teflon® and Tefzel® are registered trademarks of the DuPont Company.

Monel® is a registered trademark of Special Metals Corporation.

Kel-F® is a registered trademark of 3M Company.

PEEK™ is a trademark of Victrex PLC.

Viton® is a registered trademark of DuPont Dow Elastomers.

Outline and Mounting Dimensions

Weight = 4.4 lbs (2.0kg)

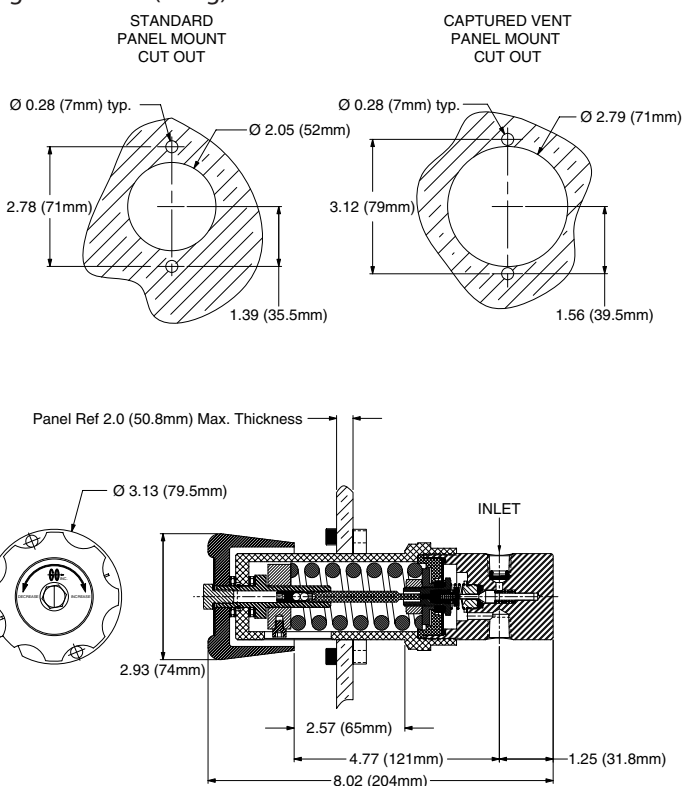

GO REGULATOR

PR-56 Series

High Pressure Brass Regulator (6,000 psig Inlet)



To meet the demands for the safe reduction of inlet pressures up to 6,000 psig, GO Regulator has designed the PR-56 Series regulator. This precision regulator features a piston sensing design which provides the operator with low adjusting torque requirements when setting the outlet pressure.

The optional self relieving feature provides an additional level in operational ease, as it allows for trapped downstream pressure to be safely vented to atmosphere through the bonnet.

Features & Specifications

- Gas or liquid service
- Brass (alloy 360) construction
- Better than 25 Ra finish in diaphragm cavity
- Stainless steel spring loaded piston sensor
- 20 micron filter
- Bubble-tight shutoff
- Viton® seals (other elastomers optional)
- Inlet pressure maximum 6,000 psig
- Outlet pressure ranges are 0–250, 0–500, 0–750, 0–1000, 0–2000, 0–4000, and 0–6000 psig
- Cv flow coefficient 0.05 or 0.2

Options

- Gauges and CGA fittings for cylinder gas application
- Self-relieving and captured vent
- 3/8" FNPT, 1/4" AN 10050-4, 1/4" SAE J514 or 1/4" MS 33649 ports

pressure regulators

GO Regulator

405 Centura Court • PO Box 4866 • Spartanburg, SC 29303

Phone (864) 574-7966 Fax (864) 574-5608

www.goreg.com • sales@goreg.com

PR-56 Series

How to Order

PR56 -

BODY MATERIAL

2 Brass

PORT CONFIGURATION

A Standard

For more port configurations, see page 35

PROCESS PORT TYPES

(GAUGE PORT TYPES, IF SPECIFIED)

- 1 1/4" FNPT (1/4" FNPT gauge ports)
- 4 3/8" FNPT (1/4" FNPT gauge ports)
- 7 AN 10050-4 (1/4" FNPT gauge ports)
- 8 SAE J514 (1/4" FNPT gauge ports)
- 9 M/S 33649 (1/4" FNPT gauge ports)
- F 1/4" Aminco (1/4" FNPT gauge ports)

SURFACE FINISH OF DIAPHRAGM CAVITY

- 1 < 25 Ra
- 5 < 25 Ra with 10-32 mounting holes

SEAT MATERIAL

- A Tefzel®
- C Polyimide
- H PCTFE (formerly Kel-F® 81)
- Q PEEK™

FLOW COEFFICIENT (Cv)

- 2 0.05
- 5 0.2

CAP ASSEMBLY

- 1 Standard, aluminum
- 4 Panel mount, aluminum
- 5 Captured vent, aluminum
- F Stainless steel
- V Captured vent, panel mount, stainless steel
- W Panel mount, stainless steel

PISTON MATERIAL

- 4 Stainless steel/Teflon® cavity o-ring
- 5 Stainless steel/Viton® cavity o-ring

PISTON TYPE

- 1 Non-self-relieving
- 3 Self-relieving

OUTLET RANGE

- I 0-250 psig
- J 0-500 psig
- W 0-750 psig
- K 0-1000 psig
- L 0-2000 psig
- N 0-4000 psig
- O 0-6000 psig

Maximum Temperature & Operating Inlet Pressures

SEAT MATERIAL	MAXIMUM TEMPERATURE	@	MAXIMUM OPERATING INLET PRESSURE
Tefzel®	150° F (66° C)	@	3600 psig (24.82 MPa)
PCTFE (formerly Kel-F® 81)	175° F (80° C)	@	6000 psig (41.37 MPa)
Polyimide	175° F (80° C)	@	6000 psig (41.37 MPa)
PEEK™	175° F (80° C)	@	6000 psig (41.37 MPa)

Outline and Mounting Dimensions

Weight = 4.4 lbs (2.0kg)

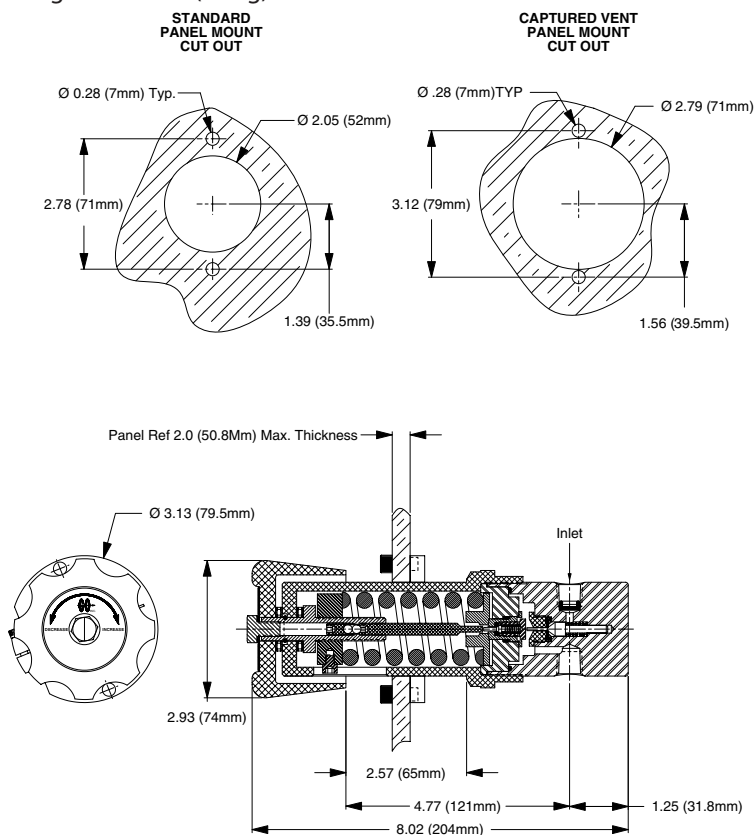

Teflon® and Tefzel® are registered trademarks of the DuPont Company.

Kel-F® is a registered trademark of 3M Company.

PEEK™ is a trademark of Victrex PLC.

Viton® is a registered trademark of DuPont Dow Elastomers.

GO REGULATOR

PR-57 Series

High Pressure Corrosion-resistant Regulator (10,000 psig Inlet)



To meet the demands for the safe reduction of inlet pressures up to 10,000 psig, GO Regulator has designed the PR-57 Series regulator. This precision regulator features a piston sensing design which provides the operator with low adjusting torque requirements when setting the outlet pressure. The body is constructed from 316L stainless steel, providing the ultimate in safety and corrosion resistance.

The optional self-relieving feature provides an additional level in operational ease, as it allows for trapped downstream pressure to be safely vented to atmosphere through the bonnet.

Features & Specifications

- Gas or liquid service
- 316L stainless steel construction
- Better than 25 Ra finish in diaphragm cavity
- Stainless steel spring loaded piston sensor
- 20 micron filter
- Bubble-tight shutoff
- Viton® seals (other elastomers optional)
- Inlet pressure maximum 10,000
- Outlet pressure ranges are 0–250, 0–500, 0–750, 0–1000, 0–2000, 0–4000, 0–6000, 0–7500 and 0–10,000 psig
- Operating temperatures -40° F to +150° F (-40° C to +66° C)
- Cv flow coefficient 0.05 or 0.2

Options

- Gauges and CGA fittings for cylinder gas application
- Self-relieving and captured vent
- 3/8" FNPT, 1/4" AN 10050-4, 1/4" SAE J514 or 1/4" MS 33649 ports

pressure regulators

GO Regulator

405 Centura Court • PO Box 4866 • Spartanburg, SC 29303

Phone (864) 574-7966 Fax (864) 574-5608

www.goreg.com • sales@goreg.com

PR-57 Series

How to Order

PR57 -

BODY MATERIAL

- 1 316L stainless steel
- 4 Monel®

PORT CONFIGURATION

- A Standard
- For more port configurations, see page 35

PROCESS PORT TYPES

(GAUGE PORT TYPES, IF SPECIFIED)

- 1 ¼" FNPT (¼" FNPT gauge ports)
- 2 ¼" tube stub, 2" long (¼" FNTP gauge ports)
- 4 ⅜" FNPT (¼" FNPT gauge ports)
- 7 AN 10050-4 (¼" FNPT gauge ports)
- 8 SAE J514 (¼" FNPT gauge ports)
- 9 M/S 33649 (¼" FNPT gauge ports)
- K ¼" sch 40 pipe stub, 4" long (¼" FNPT gauge ports)

SURFACE FINISH OF DIAPHRAGM CAVITY

- 1 < 25 Ra
- 5 < 25 Ra with 10-32 mounting holes

SEAT MATERIAL

- C Polyimide
- Q PEEK™

FLOW COEFFICIENT (Cv)

- 2 0.05
- 5 0.2

CAP ASSEMBLY

- 1 Standard, aluminum
- 4 Panel mount, aluminum
- F Stainless steel

PISTON MATERIAL

- 4 Stainless steel/Teflon® cavity o-ring
- 7 Monel®/Teflon® cavity o-ring

PISTON TYPE

- 1 Non-self-relieving
- 3 Self-relieving

OUTLET RANGE

- I 0-250 psig
- J 0-500 psig
- W 0-750 psig
- K 0-1000 psig
- L 0-2000 psig
- N 0-4000 psig
- O 0-6000 psig
- P 0-7500 psig
- Q 0-10,000 psig

Maximum Temperature & Operating Inlet Pressures

SEAT MATERIAL	MAXIMUM TEMPERATURE	@	MAXIMUM OPERATING INLET PRESSURE
Polyimide	150° F (66° C)	@	10,000 psig (68.95 MPa)
PEEK™	150° F (66° C)	@	10,000 psig (68.95 MPa)

Outline and Mounting Dimensions

Weight = 4.4 lbs (2.0kg)

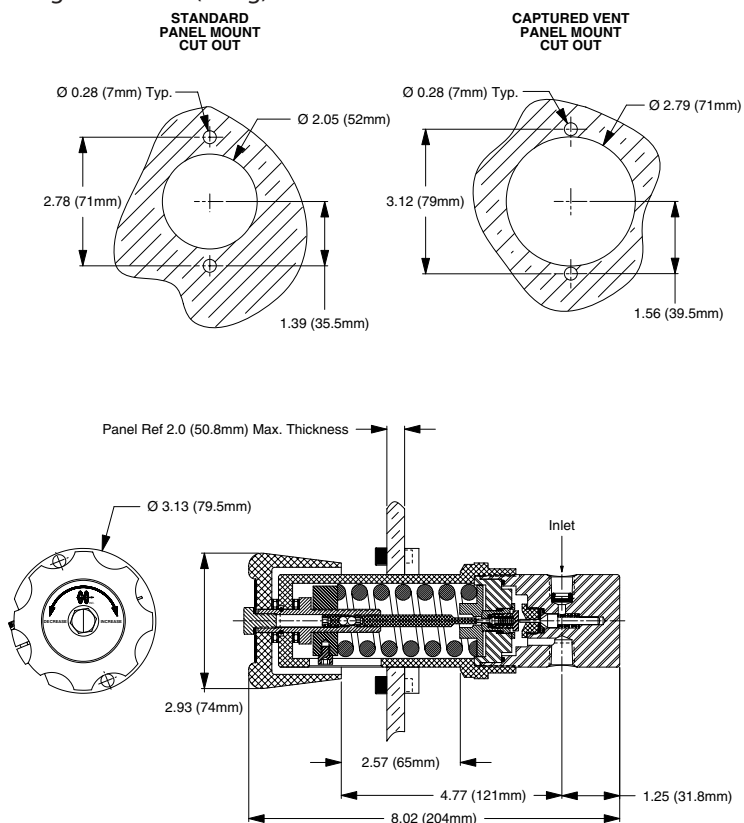

Monel® is a registered trademark of Special Metals Corporation.

PEEK™ is a trademark of Victrex PLC.

Teflon® is a registered trademark of the DuPont Company.

GO REGULATOR

PR-58 Series

Ultra High Pressure Regulators (20,000 psig Inlet)



To meet the demands for the safe reduction of inlet pressures up to 20,000 psig, GO Regulator has designed the PR-58 Series. This precision regulator features a piston sensor design which provides the operator with low adjusting torque requirements when setting the outlet pressure. The body and bonnet are constructed from 316L stainless steel, providing the ultimate in safety and corrosion resistance.

The optional self-relieving feature provides an additional level in operational ease as it allows for trapped downstream pressure to be safely vented to atmosphere through the bonnet.

Features & Specifications

- Gas or liquid service
- 316L stainless steel construction
- Better than 25 Ra finish in diaphragm cavity
- Stainless steel piston sensor
- 20 micron inlet filter
- Bubble-tight shutoff
- Viton® seals (other elastomers optional)
- Outlet pressure ranges are 0–10,000, 0–15,000 and 0–20,000 psig
- Cv flow coefficient 0.04

pressure regulators

GO Regulator

405 Centura Court • PO Box 4866 • Spartanburg, SC 29303
Phone (864) 574-7966 Fax (864) 574-5608
www.goreg.com • sales@goreg.com

PR-58 Series

How to Order

PR58 –

BODY MATERIAL

- 1 316L stainless steel
- 4 Monel®

PORT CONFIGURATION

- A Standard

For more port configurations, see page 35

PROCESS PORT TYPES

(GAUGE PORT TYPES, IF SPECIFIED)

- 1 ¼" Aminco (¼" FNPT gauge ports)
- 2 ⅜" Aminco (¼" FNTP gauge ports)

SURFACE FINISH OF DIAPHRAGM CAVITY

- 1 < 25 Ra

SEAT MATERIAL

- C Polyimide
- Q PEEK™

FLOW COEFFICIENT (Cv)

- 2 0.05

CAP ASSEMBLY

- 7 Captured vent, stainless steel
- 9 Plastic knob, stainless steel
- A Captured vent, plastic knob, stainless steel
- B Panel mount, plastic knob, stainless steel
- C Captured vent, panel mount, stainless steel
- F Standard, stainless steel
- W Panel mount, stainless steel

PISTON MATERIAL

- 4 Stainless steel/Teflon® cavity o-ring
- 5 Stainless steel/Viton® cavity o-ring
- 6 Monel®/Viton® cavity o-ring
- 7 Monel®/Teflon® cavity o-ring

PISTON TYPE

- 1 Non-self-relieving
- 3 Self-relieving

OUTLET RANGE

- Q 0–10,000 psig
- 1 0–15,000 psig
- 2 0–20,000 psig

Maximum Temperature & Operating Inlet Pressures

SEAT MATERIAL	MAXIMUM TEMPERATURE	@	MAXIMUM OPERATING INLET PRESSURE
Polyimide	120° F (49° C)	@	20,000 psig (137.9 MPa)
PEEK™	120° F (49° C)	@	20,000 psig (137.9 MPa)

Outline and Mounting Dimensions

Weight = 7.3 lbs (3.31kg)

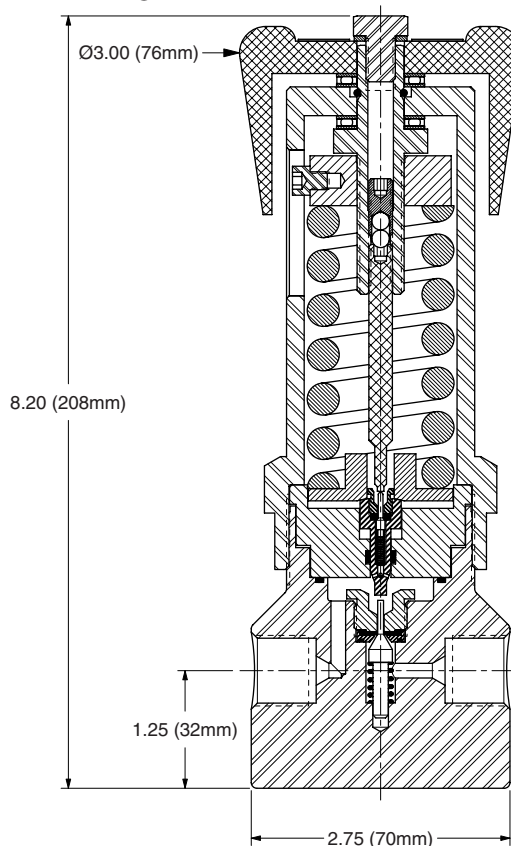

Monel® is a registered trademark of Special Metals Corporation.

PEEK™ is a trademark of Victrex PLC.

Teflon® is a registered trademark of the DuPont Company.

Viton® is a registered trademark of DuPont Dow Elastomers.

GO REGULATOR

PR-59 Series

High Pressure/High Flow Pressure Reducing Regulator



Designed for low and high pressures up to 4000 psig inlet, the PR-59 Series pressure reducing regulator controls high flow with its Cv flow coefficient of 1.2. Though normally supplied without self-relieving capability, this feature can be added as an option.

While primarily designed for use with gas streams, the PR-59 can be used with virtually any liquid systems that are compatible with the seals. A large size piston sensor gives good sensitivity of control even at low outlet pressures and the Kel-F® valve seat assembly gives normal bubble-tight shutoff.

Features & Specifications

- 316L stainless steel, brass and Monel® body construction
- Inlet pressure capability up to 4000 psig
- Outlet control ranges from 250 psig up to 4000 psig
- Optional self-relieving feature
- Inlet and outlet ports of ½" or ¾" FNPT with ¼" FNPT gauge ports optional
- Balanced poppet valve design for constant pressure control
- Viton® seals (other elastomers optional)
- PCTFE seat
- Cv flow coefficient is 1.2
- Operating temperatures of -40° F to +175° F (-40° C to +80° C)

pressure regulators

GO Regulator

405 Centura Court • PO Box 4866 • Spartanburg, SC 29303

Phone (864) 574-7966 Fax (864) 574-5608

www.goreg.com • sales@goreg.com

PR-59 Series

How to Order

PR59 –

BODY MATERIAL

- 1 316L stainless steel
- 2 Brass
- 4 Monel®

PORT CONFIGURATION

- A Standard

For more port configurations, see page 35

PROCESS PORT TYPES

(GAUGE PORT TYPES, IF SPECIFIED)

- 5 ½" FNPT (¼" FNPT gauge ports)
- A ¾" FNPT (¼" tube gauge ports)
- B ¾" ISO-7 parallel (¼" FNPT gauge ports)

SURFACE FINISH OF DIAPHRAGM CAVITY

- 1 < 25 Ra

SEAT MATERIAL

- H PCTFE (formerly Kel-F® 81)
- I Teflon® (0–1000 psig maximum inlet)

FLOW COEFFICIENT (Cv)

- 9 1.2

CAP ASSEMBLY

- 1 Standard, stainless steel
- 4 Panel mount, stainless steel
- 5 Captured vent, stainless steel
- 6 Captured vent, panel mount, stainless steel
- 9 Plastic knob, stainless steel
- A Captured vent, plastic knob, stainless steel
- B Panel mount, plastic knob, stainless steel

PISTON MATERIAL

- 5 Stainless steel
- B Monel®

PISTON TYPE

- 1 Non-self-relieving
- 3 Self-relieving

OUTLET RANGE

- I 0–250 psig
- J 0–500 psig
- W 0–750 psig
- K 0–1000 psig
- L 0–2000 psig
- N 0–4000 psig

Maximum Temperature & Operating Inlet Pressures

SEAT MATERIAL	MAXIMUM TEMPERATURE	@	MAXIMUM OPERATING INLET PRESSURE
PCTFE (formerly Kel-F® 81)	175° F (80° C)	@	4000 psig (27.58 MPa)
Teflon®	150° F (66° C)	@	1000 psig (6.90 MPa)

Outline and Mounting Dimensions

Weight = 4.4 lbs (2.0kg)

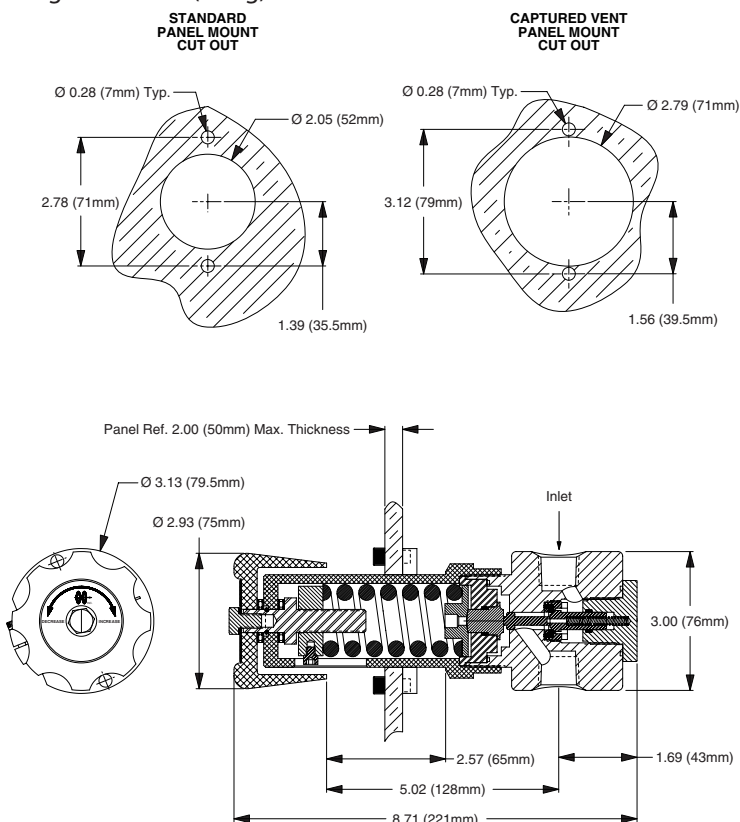

Kel-F® is a registered trademark of 3M Company.

Viton® is a registered trademark of DuPont Dow Elastomers.

Monel® is a registered trademark of Special Metals Corporation.

Teflon® is a registered trademark of the DuPont Company.

Porting Configurations for Single Stage Pressure Regulators

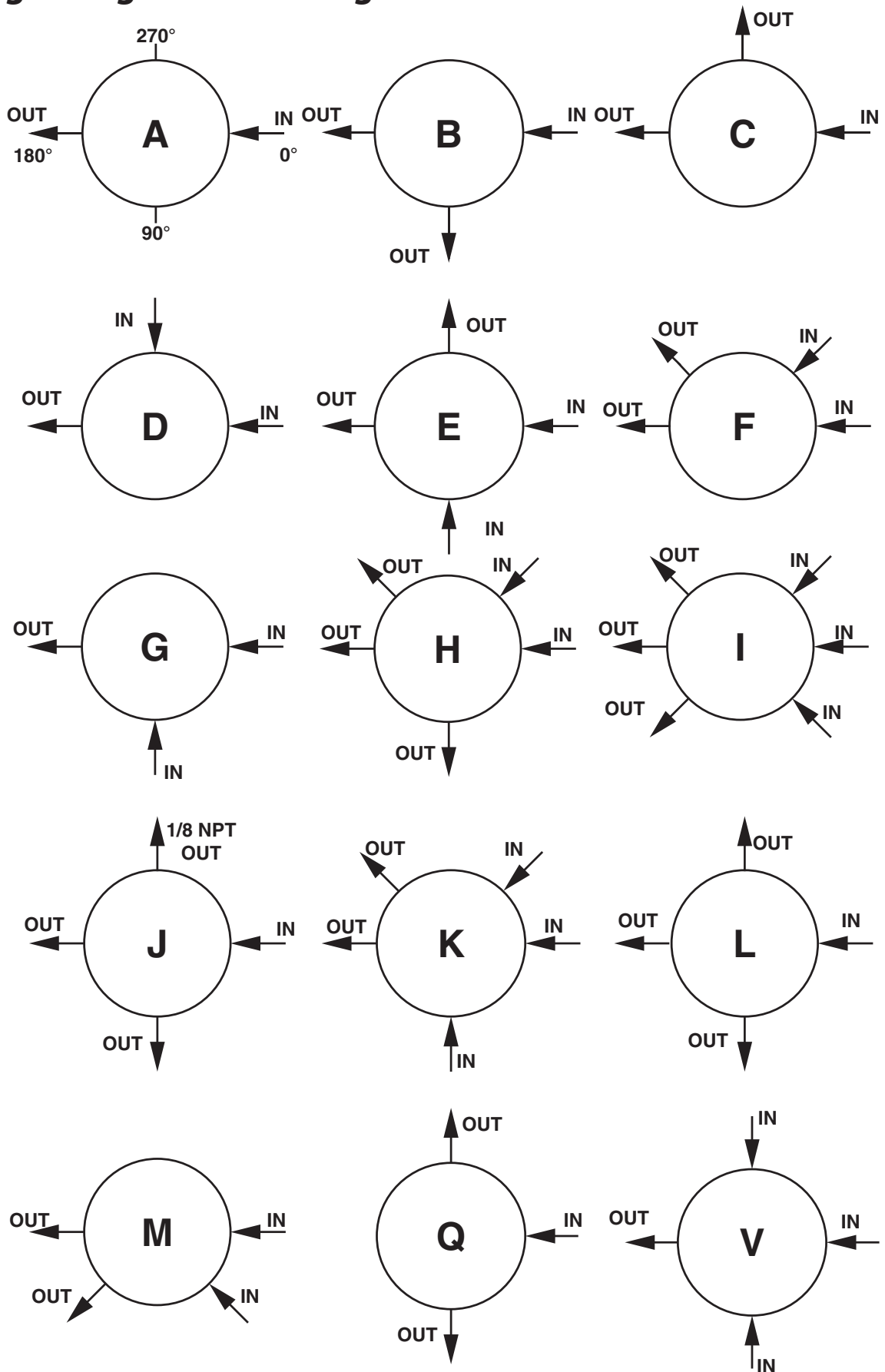

LOCATION OF PORTS FROM
TOP VIEW



CIRCOR Instrumentation Technologies

405 Centura Court
PO Box 4866
Spartanburg, SC 29303
Tel (864) 574-7966
Fax (864) 587-5608
www.circortechnologies.com

Circle Seal Controls, Inc.

2301 Wardlow Circle
Corona, CA 92880
Tel (909) 270-6200
Fax (909) 270-6201
www.circle-seal.com

HOKE GmbH

Weitzesweg 11
Postfach 15 41
D-61118 Bad Vilbel-Dortelweil
Tel +49 6101 82 56 0
Fax +49 6101 82 56 40
www.hoke.de

CIRCOR Instrumentation, Ltd.

1-3 Bouverie Road
Harrow
Middlesex, HA1 4HB
Tel +44 (0) 20 8423 0113
Fax +44 (0) 20 8864 7008
www.circor.co.uk

HOKE, Inc.

405 Centura Court
PO Box 4866
Spartanburg, SC 29303
Tel (864) 574-7966
Fax (864) 587-5608
www.hoke.com

CIRCOR Tech

405 Centura Court
Spartanburg, SC 29303
Tel (864) 574-7966
Fax (864) 587-5608
www.circortech.com

Panels Plus

1901 Lynx Place
Ontario, CA 91761
Tel (909) 923-3770
Fax (909) 923-2550
www.circor-panelsplus.com

GO Regulator

405 Centura Court
PO Box 4866
Spartanburg, SC 29303
Tel (864) 574-7966
Fax (864) 587-5608
www.goreg.com

TOMCO

51 Zima Park
PO Box 4866
Spartanburg, SC 29303
Tel (864) 574-7966
Fax (864) 587-5608
www.tomcoquickcouplers.com

HOKE Controls

2301 Wardlow Circle
Corona, CA 92880
Tel (909) 898-6100
Fax (909) 898-6119

LIMITED WARRANTY

ALL CIRCLE SEAL CONTROLS, INC., GO REGULATOR, AND HOKE INC. PRODUCTS ARE MADE TO EXACTING STANDARDS OF DESIGN, MATERIAL, WORKMANSHIP AND QUALITY CONTROL AND ARE WARRANTED TO BE FREE OF DEFECTS IN MATERIAL AND WORKMANSHIP AND REASONABLY FIT FOR THE USES SET FORTH IN SELLER'S CATALOG OR THE CONTRACT SPECIFICATIONS FOR A PERIOD OF ONE YEAR AFTER SALE IF PROPERLY INSTALLED AND MAINTAINED AND UNDER THE NORMAL USE AND SERVICE FOR WHICH THE EQUIPMENT IS INTENDED. BUYER TO INSPECT THE GOODS WITHIN TEN DAYS OF DELIVERY AND TO THEN IMMEDIATELY NOTIFY SELLER OF ANY DEFECTS IN ORDER TO CLAIM A DEFECT. THIS WARRANTY IS IN LIEU OF ALL OTHER WARRANTIES WHETHER THEY ARE STATUTORY, EXPRESS OR IMPLIED, INCLUDING AMONG OTHER THINGS ANY IMPLIED WARRANTY OF MERCHANTABILITY FITNESS FOR A PARTICULAR PURCHASE NOT SET FORTH IN SELLER'S CATALOG, AND ALSO DOES NOT APPLY TO ANY PRODUCTS OF SELLER WHICH HAVE BEEN REPAIRED, ALTERED OR MODIFIED OR HAVE BEEN SUBJECT TO MISUSE OR ABUSE. SELLER IS NOT LIABLE FOR ANY CONSEQUENTIAL, INCIDENTAL OR SPECIAL DAMAGES RESULTING DIRECTLY OR INDIRECTLY FROM THE DESIGN, MATERIAL, WORKMANSHIP, OPERATION OR INSTALLATION OF ANY OF ITS PRODUCTS AND NEITHER ASSUMES NOR AUTHORIZES ANY OTHER PERSON TO ASSUME FOR IT ANY OTHER LIABILITY IN CONNECTION THEREWITH. BUYER'S EXCLUSIVE REMEDY SHALL BE THE REPAIR OR REPLACEMENT OF ANY SUCH DEFECTIVE PRODUCT AFTER VERIFICATION BY SELLER. THIS WARRANTY IS IN EFFECT UNLESS SUPERSEDED BY LIMITED WARRANTY, FORM NO. 2299 (4/83)