

# THE FUNDAMENTALS OF AC ELECTRIC INDUCTION MOTOR DESIGN AND APPLICATION

by

**Edward J. Thornton**

Electrical Consultant

E. I. du Pont de Nemours

Houston, Texas

and

**J. Kirk Armintor**

Senior Account Sales Engineer

Rockwell Automation

The Woodlands, Texas



*Edward J. (Ed) Thornton is an Electrical Consultant in the Electrical Technology Consulting Group in Engineering at DuPont, in Houston, Texas. His specialty is the design, operation, and maintenance of electric power distribution systems and large motor installations. He has 20 years of consulting experience with DuPont.*

*Mr. Thornton received his B.S. degree (Electrical Engineering, 1978) from Virginia Polytechnic Institute and State University.*

*He is a registered Professional Engineer in the State of Texas.*



*J. Kirk Armintor is a Senior Account Sales Engineer in the Rockwell Automation Houston District Office, in The Woodlands, Texas. He has 32 years' experience with motor applications in the petroleum, chemical, paper, and pipeline industries. He has authored technical papers on motor restoration, AC inverter applications, and motor repair standards.*

*Mr. Armintor received his B.S. degree (Electrical Engineering, 1970) from Lamar*

*University.*

## ABSTRACT

The conversion of electrical energy into mechanical energy has been and continues to be a dominant form of power transmission for industrial purposes. The alternating current (AC) electric induction motor has been an industry workhorse for electro-mechanical conversion for over 100 years. This tutorial will introduce the user to the fundamental electrical and mechanical principles of AC electric induction motor design and application. Specific emphasis will be given to pump applications.

## INTRODUCTION

Electromechanical energy conversion involves the interchange of energy between an electrical system and a mechanical system through the medium of a coupling magnetic field. When the conversion takes place from electrical to mechanical form, the device is called a motor. The primary quantities involved in the electrical system are voltage (E) and current (I), while the analogous quantities in the mechanical system are torque (T) and speed ( $\omega$ ), respectively. Figure 1 shows a block representation of this energy conversion for motor action.

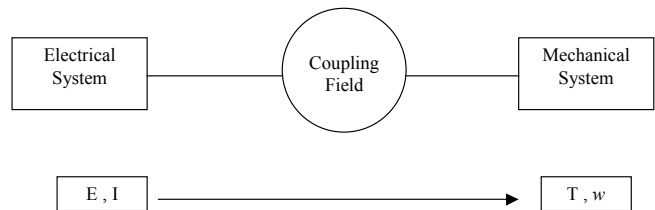

Figure 1. Block Representation of Energy Conversion for Motors.

The coupling magnetic field is key to the operation of electrical apparatus such as induction motors. The fundamental laws associated with the relationship between electricity and magnetism were derived from experiments conducted by several key scientists in the 1800s.

## Basic Design and Theory of Operation

The alternating current (AC) induction motor is one of the most rugged and most widely used machines in industry. There are two major components of an AC induction motor. The stationary or static component is the stator. The rotating component is the rotor. The stator is composed of laminations of high-grade sheet steel. The inner surface is slotted to accommodate windings. In Figure 2 a three-phase winding is represented by the three coils, the axes of which are 120 electrical degrees apart.

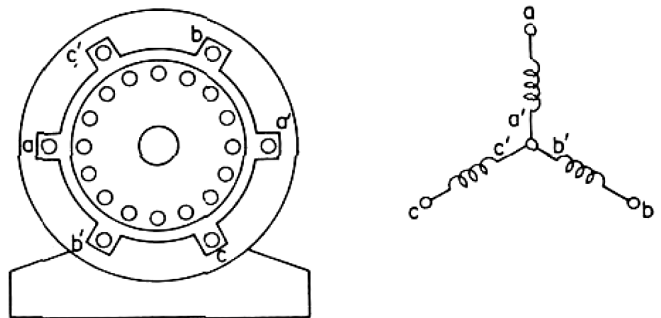

Figure 2. Three-Phase Induction Motor Showing Stator, Rotor, and Schematic Representation of Y-Connected Stator Winding.

Coil  $aa'$  represents all the coils assigned to phase  $a$  for one pair of poles. Similarly coil  $bb'$  represents phase  $b$  coils, and  $cc'$  represents phase  $c$  coils. When one end of each phase is commonly connected, as shown in Figure 2, the three-phase winding is said to be Y-connected. Such a winding is called a three-phase winding because the voltages induced in each of the three phases by a

revolving flux-density field are out of phase by 120 electrical degrees. This is a distinguishing characteristic of a symmetrical three-phase system. The rotor also consists of laminations of slotted ferromagnetic material, but the rotor winding may be either the squirrel-cage type or the wound-rotor type. The latter is of a form similar to that of the stator winding. The winding terminals are brought out to three slip rings. This allows an eternal three-phase resistor to be connected to the rotor winding for the purpose of providing speed control. The squirrel-cage winding consists merely of a number of bars imbedded in the rotor slots and connected at both ends by means of end rings. The bars and rings are either copper or aluminum. The squirrel-cage construction is not only simpler and more economical than the wound-rotor type but more rugged as well. In normal operation a three-phase voltage is applied to the stator winding at points *a-b-c* in Figure 2. The magnetizing currents flow in each phase that together create a revolving magnetic field having two poles. The speed of the field is fixed by the frequency of the magnetizing currents and the number of poles for which the stator winding is designed. Figure 2 shows the configuration of two poles. If the pattern *a-c'-b-a'-c-b'* is made to span only 180 mechanical degrees and then is repeated over the remaining 180 mechanical degrees, a motor having a four-pole field distribution results. For a *p*-pole motor the basic winding pattern must be repeated  $p/2$  times within the circumference of the inner surface of the stator. The revolving field produced by the stator winding cuts the rotor conductors, thereby inducing voltages. Since the rotor winding is short-circuited by the end rings, the induced voltages cause currents to flow, which in turn react with the field to produce electromagnetic torque and motor action results. Another important point is that the induction motor is singly excited, i.e., electrical power is applied only to the stator winding. Current flows through the rotor winding by induction. As a consequence both the magnetizing current, which sets up the magnetic field, and the power current, which allows energy to be delivered to the shaft load, flow through the stator winding. For this reason, and in the interest of keeping the magnetizing current as small as possible in order that the power component may be correspondingly larger for a given rating, the air gap of induction motors is made as small as mechanical clearance will allow.

The rotating magnetic field is produced by the contributions of space-displaced phase windings carrying appropriate time-displaced currents. The application of three-phase currents through a balanced three-phase winding produces a rotating magnetic field that is both constant in amplitude and constant in speed. In general, for a *q*-phase motor, a rotating field of constant amplitude and constant speed results when the following conditions are satisfied:

- There is *space* displacement between balanced phase windings of  $2\pi/q$  electrical degrees, and
- The currents (*i*) flowing through the phase windings are balanced and *time*-displaced by  $2\pi/q$  electrical degrees

where:

*p* is the number of poles

*q* is the number of electrical phases

*i* is the current in the phase windings

This relationship is illustrated in Figure 3.

## MOTOR NAMEPLATE

### What Is on a Motor Nameplate?

A typical plant store's description of a motor will have horsepower, speed, voltage, and enclosure. The requisition says maybe "15 hp, 1800 rpm, 440 volts, TEFC." A new motor nameplate says "HP 15, RPM 1748, Enclosure TEFC, Des B, Frame xxxT, Amps x.0, PH 3, HZ 60, Duty Cont, Volts 460, Type P, Amb 40 C, SF 1.15, INS CL F, EFF xx.x, P.F. 80, DE bearing 35BC02JGG30A26, ODE bearing 30BC02JGG30A26" (Figure 4).

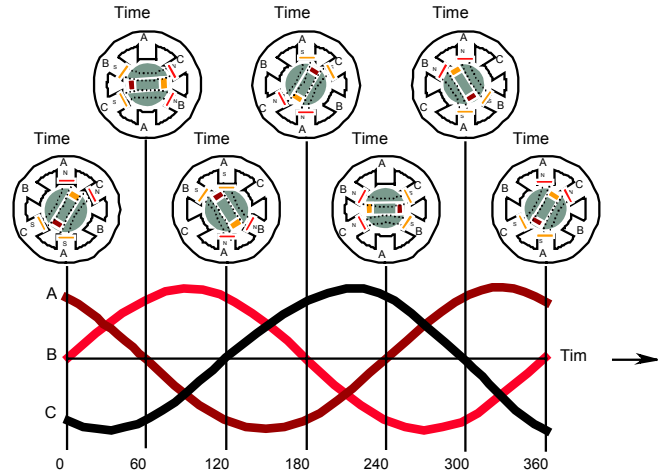

Figure 3. Relationship of Three-Phase Currents and Rotating Magnetic Field Over 360 Electrical Degrees in Time.

Should you reject the motor because it is not rated 1800 rpm? What does the extra information on the nameplate mean? Do you care? The answers are "maybe," and "you probably should."

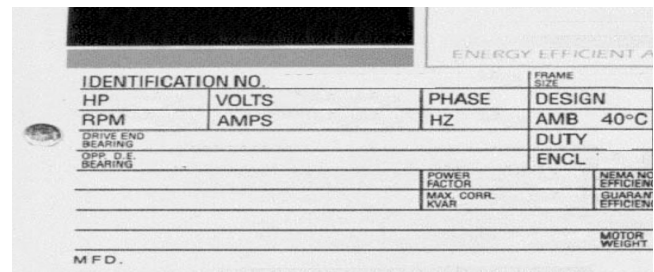

Figure 4. Typical Motor Nameplate Information.

To define the basic performance and mounting parameters of a motor, the National Electrical Manufacturers Association (NEMA) defines some basic design and dimensional parameters in NEMA Standard Publication MG 1 (1993). These parameters are then coded onto the motor nameplate to give you a basic definition of what you have received. Manufacturers often include additional information to further define some key motor features. NEMA Standard Publication Section MG 1-10.40 (1993), "Nameplate Mark for Medium Single-Phase and Polyphase Induction Motors," requires the following minimum amount of information be given on all nameplates of single-phase and polyphase induction motors.

- Manufacturer's type and frame designation
- Horsepower output
- Time rating
- Maximum ambient temperature for which motor is designed
- Insulation system designation
- RPM at rated load. Frequency.
- Number of phases
- Rated load current
- Voltage
- Code letter for locked rotor kVA
- Design letter for medium motors
- NEMA nominal efficiency when required by MG 1-12.55
- Service factor if other than 1.0

- For motors equipped with thermal protectors, the words “thermally protected,” if the motor provides all the protection described in NEMA MG 1-12.52 (1993). For motors rated above 1 hp equipped with overtemperature devices or systems, the words “OVER TEMP. PROT.,” with a type number as described in MG 1-12.53 (1993) inserted in the blank would identify the protection type.

The information on a motor nameplate can be arranged in categories. By definition, an induction motor converts electrical energy to useful mechanical energy. With rated electrical input the motor will deliver rated output shaft power. There are established standard indicators of how effective the motor does its job, as well as data on the nameplate concerning safety and reliability. The following information provides a brief definition and some application considerations regarding motor data on the nameplate.

#### Electrical Input

**Voltage**—The voltage at which the motor is designed to operate is an important parameter. Standard voltage for motors built to NEMA MG 1 (1993) are defined in MG 1-10.30. One common misapplication is of motors nameplated (rated) at one voltage but applied on a different voltage network using the + 10 percent voltage tolerance for “successful” operation. Nameplate-defined parameters for the motor such as power factor, efficiency, torque, and current are at rated voltage and frequency. Application at other than nameplate voltage will likely produce different performance. It is common for manufacturers to nameplate a wide variety of voltages on one motor nameplate. A common example is a motor wound for 230 and 460 V (230/460 V) but operable on 208 V. This 208-230/460 V motor will have degraded performance at 208 V. Another common misconception is to request a motor rated at network voltage, for example, at 480 V. The NEMA standard is 460 V. The voltage rating assumes that there is voltage drop from the network to the motor terminals. Thus, the 460 V motor is appropriate on a 480 V network.

**Frequency**—Input frequency is usually 50 or 60 Hz. When more than one frequency is nameplated, other parameters that will differ at different input frequencies must be defined on the nameplate. The increased use of adjustable frequency drives (AFDs) for motor control is also making it necessary to nameplate a frequency range, especially for hazardous duty listed applications.

**Phase**—This represents the number of AC power lines supplying the motor. Single- and three-phase are the norms.

**Current**—Rated load current in amps is at nameplate horsepower (HP) with nameplate voltage and frequency. When using current measurement to determine motor load, it is important that correction be made for the operating power factor. Unbalanced phases, under voltage conditions, or both, cause current to deviate from nameplate AMPS. Review both motor and drive for a matched system regarding current on AFD applications.

**Code**—A letter code defines the locked rotor kVA on a per-hp basis. Codes are defined in MG1-10.37.2 (1993) by a series of letters from A to V. Generally, the farther the code letter from A, the higher the inrush current per hp. A replacement motor with a “higher” code may require different upstream electrical equipment, such as motor starters.

**Type**—NEMA MG 1 (1993) requires manufacturer’s type, but there is no industry standard regarding what this is. Some manufacturers use “Type” to define the motor as single or polyphase, single or multispeed, or even by type of construction. Type is of little use in defining a motor for replacement purposes unless you also note the specific motor manufacturer.

**Power factor**—Also given on the nameplate as “P.F.” or PF,” power factor is the ratio of the active power (W) to the apparent power (VA) expressed as a percentage. It is numerically equal to the cosine of the angle of lag of the input current with respect to its voltage, multiplied by 100. For an induction motor, power factor

also varies with load. The nameplate provides the power factor for the motor at full load. Active power is the power that does work; apparent power has a reactive component. This reactive component is undesirable—the utility company must supply it, but it does no work. A power factor close to unity (100 percent) is most desirable. Because there are tradeoffs when designing an induction motor for improved efficiency or other performance parameters, power factor sometimes suffers. It can be improved by adding capacitors.

**Capacitor correction**—The nameplate may list the maximum power-factor correcting capacitor size. Nameplate notation would be something like “MAX CORR KVAR” followed by a number. The number would indicate capacitor value in kilovars. A value greater than that suggested may result in higher voltages than desired and could cause damage to the motor or other components.

#### Mechanical Output

**Horsepower**—Shaft horsepower is a measure of the motor’s mechanical output rating, its ability to deliver the torque required for the load at rated speed. It is usually given as “HP” on the nameplate. In general horsepower (hp) = (torque) × (speed) / 5250 where:

Torque is in lb-ft

Speed is in rpm

**Full-load speed**—The speed at which rated full-load torque is delivered at rated power output is full-load speed. It is generally given as “RPM” on the nameplate. This speed is sometimes called “slip” speed or actual rotor speed rather than synchronous speed. Synchronous speed is the speed at which the motor would run if it were fixed to the AC power line frequency; that is, if it turned at the same speed as the rotating magnetic field created by the combination of winding pattern and power line frequency. An induction motor’s speed is always less than synchronous speed and it drops off as load increases. For example for 1800 rpm synchronous speed, an induction motor might have a full-load speed of 1748 rpm. There have been conflicting opinions and claims regarding the effect of replacing a “standard-efficiency” motor with an “energy-efficient” motor on a centrifugal-type load. Centrifugal pumps and fans impose what is often called a “cubed-exponential load” on the driver. For such a pump or fan, torque varies approximately as the square of speed. Because, by definition, power varies directly with torque and with speed, for a centrifugal-type load, power varies approximately as the cube of speed—a small speed change produces a much larger change in power requirement. For example, a 1 percent increase in speed would bring a 3 percent increase in load:

$$(1.01)^3 = 1.03 \quad (1)$$

Some engineers claim that an energy-efficient motor manifests most of its efficiency improvement as a lower slip speed; that is, as an increase—typically about 1 percent—in output speed. Because the 1 percent speed gain equates to a 3 percent horsepower requirement, they reason, the replacement energy-efficient motor may have to be 1 hp-size larger than the standard motor. The contention does not fully account for the fact that the power reduction from using an energy-efficient motor is greater than the extra power required by the load—hence, there is a net energy savings and the motor will run cooler, potentially extending insulation life.

**Design**—NEMA MG 1 (1993), Section MG 1-1.16, defines “design,” which defines the torque and current characteristics of the motor. Letters are assigned the defined categories. Most motors are Design B, although the standard also defines Designs A, C, and D. Common headings on nameplates include “Des,” “NEMA Design,” and “Design.”

Some motors may not conform to any torque-current characteristics defined in MG 1. The motor manufacturer may assign them a

letter that is not a defined industry standard. It is important to check the design letter when replacing a motor in an existing application. Design B constrains the motor designer to limit inrush current to established standards. This ensures that the user's motor-starting devices are suitable. Design A motors have torque characteristics similar to those of the Design B motors, but there is no limit on starting inrush current. This may cause starter sizing problems. You should be aware of this and work with the motor manufacturer to ensure successful operation of your motor systems.

#### Performance

*NEMA nominal efficiency*—Efficiency is defined as output power divided by input power expressed as a percentage:

$$\left(\frac{\text{Output}}{\text{Input}}\right) \times 100 \quad (2)$$

NEMA nominal efficiency on a nameplate represents an average efficiency of a large population of like motors. The actual efficiency of the motor is guaranteed by the manufacturer to be within a tolerance band of this nominal efficiency. The band varies depending on the manufacturer. However, NEMA has established the maximum variation allowed. The maximum allowed by NEMA standards represents an additional 20 percent of motor losses from all sources, such as friction and windage losses, iron losses, and stray load losses. Therefore, you should pay attention to guaranteed minimum efficiencies when evaluating motor performance.

*Service factor*—The service factor (S.F.) is required on a nameplate only if it is higher than 1.0. Industry standard service factor includes 1.15 for open-type motors and 1.0 for totally-enclosed-type motors. However, service factors of 1.25, 1.4, and higher exist. It is not considered good design practice to use the rating afforded by S.F. continuously; operating characteristics such as efficiency, power factor, and temperature rise will be affected adversely.

*Duty*—This block on the nameplate defines the length of time during which the motor can carry its nameplate rating safely. Most often, this is continuous (“Cont”). Some applications have only intermittent use and do not need motor full-load continuously. Examples are crane, hoist, and valve actuator applications. The duty on such motors is usually expressed in minutes.

#### Safety

*Special markings*—Many motor nameplates have special markings to reflect third-party certification or recognition. Some common markings are:

- Canadian Standards Association (CSA), which indicates that the manufacturing system and the motor components meet the standards of, and are continually reviewed by, the Canadian Standards Association.
- Underwriters Laboratories (UL), which indicates that the manufacturing system and the motor components meet the standards of, and are continually reviewed by, Underwriters Laboratories. Alternatively, these motors may display “Underwriters Laboratories File #XXX.”

Other special markings may be displayed, such as those of agencies wishing to establish an efficiency certification. You should understand if any special third-party certifications are required and where you can find the proof. A growing area of nameplate marking relates to capabilities of a motor when used on an adjustable speed drive. Many standard motors are applied to AFDs using general rules of thumb, without the motor manufacturer even knowing of the application. However, given the proper information about the AFD and the application, a motor manufacturer can design a motor or properly apply an existing design, and stamp the approved parameters on the nameplate. This stamping is always required on UL-listed explosion-proof motors.

#### Reliability

*Insulation class*—Often abbreviated “INSUL CLASS” on nameplates, it is an industry standard classification of the thermal tolerance of the motor winding. Insulation class is a letter designation such as “A,” “B,” or “F,” depending on the winding's ability to survive a given operating temperature for a given life. Insulations of a letter deeper into the alphabet perform better. For example, class F insulation has a longer nominal life at a given operating temperature than class A, or for a given life it can survive higher temperatures. Operating temperature is a result of ambient conditions plus the energy lost in the form of heat (causing the temperature rise) as the motor converts electrical to mechanical energy.

*Maximum ambient temperature*—The nameplate lists the maximum ambient temperature at which the motor can operate and still be within the tolerance of the insulation class at the maximum temperature rise. It is often called “AMB” on the nameplate and is usually given in degrees centigrade.

*Altitude*—This indicates the maximum height above sea level at which the motor will remain within its design temperature rise, meeting all other nameplate data. If the motor operates below this altitude, it will run cooler. At higher altitudes, the motor would tend to run hotter because the thinner air cannot remove the heat so effectively, and the motor may have to be derated. Not every nameplate has an altitude rating.

#### Construction

*Enclosure*—This designation, often shown as “ENCL” on a nameplate, classifies the motor as to its degree of protection from its environment, and its method of cooling. In MG 1, NEMA (1993) describes many variations. The most common are open drip-proof (ODP) and totally enclosed fan cooled (TEFC).

- *ODP*—An open drip-proof motor allows a free exchange of air from outside the motor to circulate around the winding while being unaffected by drops of liquid or particles that strike or enter the enclosure at any angle from zero to 15 degrees downward from the vertical.
- *TEFC*—A totally enclosed fan cooled motor prevents free exchange of air between inside and outside the motor enclosure. It has a fan blowing air over the outside of the enclosure to aid in cooling. A TEFC motor is not considered air- or water-tight; it allows outside air containing moisture and other contaminants to enter, but usually not enough to interfere with normal operation. If contamination is a problem in a given application, most manufacturers can provide additional protection such as mill and chemical duty features, special insulations and internal coating, or space heaters for motors subject to extended shutdown periods and wide temperature swings that could make the motor “breathe” contaminants.
- *Explosion-proof, dust ignition-proof*—These are variations of totally enclosed motors that are for use in Division 1 hazardous atmospheres as defined in Article 500 of the National Electrical Code® (NEC, 2002). The enclosure designation on the nameplate is typically TEFC or totally enclosed nonventilated (TENV). The only indication that the motor is suitable for the hazardous atmosphere is a UL label indicating the atmosphere in which the motor may be applied, and a temperature code designation. Explosion-proof motors must contain any explosions of the specified atmosphere inside the motor. Moreover, they will not let the surface temperature exceed the limits of the temperature code even at fault conditions such as overload or locked rotor. The dust ignition-proof motor is designed to have the features of an explosion-proof motor as well as to exclude ignitable amounts of dust.
- *Hazardous location - Division 2*—At normal conditions the motor would not be exposed to the flammable atmosphere. The NEC (2002) Article 501-8b states that open or nonexplosion-proof

enclosures without arc-producing devices are allowed. It also says it is important to consider the temperature of internal or external surfaces that may be exposed to the flammable atmosphere.

Some manufacturers offer special TEFC designs and third-party certification such as CSA for the specific Division 2 area classification. The nameplate for some manufacturers will also indicate that the motor is designed accordingly. Manufacturers produce many variations of these enclosures to suit specific applications.

*Frame*—This nameplate block can offer a lot of information if the motor is nearly standard. The frame size sets important mounting dimensions such as foot hole mounting pattern, shaft diameter, and shaft height. NEMA standards do not set some dimensions that can turn out to be important if the motor must fit into a confined space. These include maximums of overall height and length, and maximum conduit-box extensions. The data in the “Frame” block can be hard to interpret when special shafts or mounting configurations are used. Some examples of frame designation are as follows:

- 445T—This motor is a modern standard T-frame motor. Critical mounting dimensions for all manufacturers are as defined in NEMA Standard MG 1 (1993).
- 445TC—This T-frame motor has a standard NEMA-defined C-face.
- 445TD—This T-frame motor has a standard NEMA-defined D-flange.
- 445U—The dimensions of a U-frame motor are defined by NEMA standards prior to 1965. The U-frame is the predecessor to the present T-frame motor, and typically it has the equivalent horsepower capability of a T-frame motor that is two frame sizes smaller. For example, the T-frame equivalent of a 445U frame motor for 100 hp at 1800 rpm is a 405T motor for the same power and speed.

The first two digits of the frame size divided by four define the height of the shaft centerline from the bottom of the feet. Thus, the shaft height of a 445T motor is  $44 / 4 = 11$  inches. The third digit in the frame size determines the distance between the foot holes nearest the shaft and the opposite drive-end foot holes. Many manufacturers drill multiple foot holes in motor bases to allow mounting in short or longer frame positions. For example, a 445T motor base may have mounting holes for 444T and 445T motors. There are some catchall designations that may follow the standard frame number. For example, 445TZ indicates that all frame dimensions are standard except for the shaft. A “Y” following the standard frame designation, such as 445TY, indicates special mounting dimensions such as special flanges or frames. If special dimension designations appear, be sure to contact the motor manufacturer for dimensional information for a replacement.

*Bearings*—Though NEMA does not require it, many manufacturers supply nameplate data on bearings, because they are the only true maintenance components in an AC motor. Such information is usually given for both the drive-end bearing and the bearing opposite the drive end. Nameplate designations vary from one manufacturer to another. For rolling-element bearings, the most common is the “Anti-Friction Bearing Manufacturers Association (AFBMA) number.” That is the number that identifies the bearing by standards of the Anti-Friction Bearing Manufacturers Association. It provides much information about the bearings and lets you buy bearings from a local distributor. Some manufacturers use a simplified designation simply indicating the bearing size and type—for example, 6309 for a size 309 ball bearing. This brief information can leave questions such as, “Is the bearing sealed, shielded, or open?” Still, some manufacturers may use special bearings and elect to display their own bearing part numbers on the nameplate. Many special bearings are applied in motors for reasons such as high speed, high temperature, high thrust, or low noise. It pays to understand the bearing requirements in your motor.

*Other data*—A typical nameplate also includes the motor’s brand name, and it includes a “Serial Number” or other identifying number unique to that motor, which would let the manufacturer trace the motor back through the manufacturing process. The nameplate also includes the manufacturer’s name, and its principal city and state and “Made in U.S.A.” if U.S. made. The nameplate is a treasury of important information about a motor. If you specify, buy, maintain, or replace motors, you should know how to read them.

## MOTOR ENCLOSURES

The word “enclosure” alone as it relates to a motor is incomplete. Motors have “protective enclosures.” In some industrial applications, motors practically need suits of armor because there is much to protect against. A motor’s inside parts may have to be protected from falling objects, chemical vapors, all kinds of abrasive or metallic dust, and corrosive or explosive gases. All these enemies can be found indoors or outdoors in one industry or another. Outdoors the air may be much cleaner but the motor’s internals still need protection from high winds, driving sleet, rain, and snow. Combinations or concentrations of the attack elements will quickly destroy vital motor parts such as insulation and bearings. The objectives are to protect the internal motor parts, to do it economically, and also to keep the inside of the motor cool. NEMA has standards for different protective enclosures. Enclosures are defined by their level of environmental protection and method of cooling. The NEMA standard enclosures are divided into two broad categories: “Open” and “Enclosed.” Each enclosure type is best suited for a particular application with some enclosures giving much more protection than others.

### Open Types

Enclosures that are completely open are comparatively rare. Most open enclosures have been replaced by the “open drip-proof” or “open-protected” enclosure design. A completely open enclosure has no restriction to ventilation other than what is required for mechanical construction. An open enclosure offers excellent cooling but gives no protection at all against falling objects, moisture, chemicals, or dust. Figures 5 and 6 are two examples of open enclosures with different degrees of protection.



Figure 5. Open Enclosure—Example 1.

Figure 5 enclosure intakes air directly into the motor stator from each end of the enclosure and exhausts out the ports at the top and the bottom. Moisture, dirt, and gases will be drawn directly to the windings of the stator. Figure 6 is the same stator design with solid end brackets with an air hood to direct the air intake through the top sides of the air hood, through filters into each end of the motor and exhaust out ports into a deflector baffle to the outside

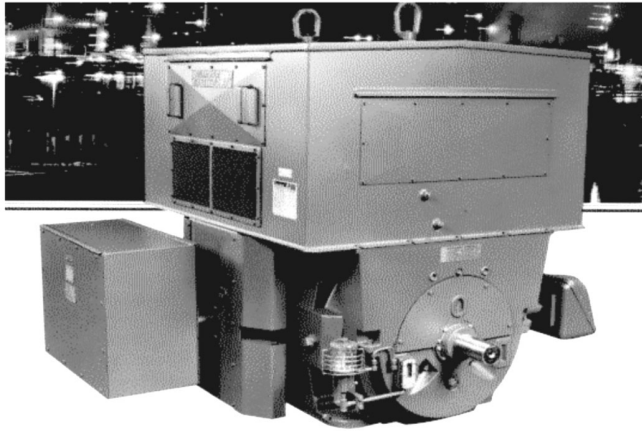

Figure 6. Open Enclosure—Example 2.

atmosphere. This is defined as a Weather Protected II enclosure. The cooling air must take several turns before reaching the stator coils, thus reducing the solids reaching the motor stator.

*Closed Types*

Motors that are used in dusty or corrosive atmospheres normally have an enclosure that is “totally-enclosed.” Totally enclosed motors have enclosures designed to exclude outside ventilating or from contact with the motors internal parts although they are not actually air-tight. The frame and end shields form a solid enclosure that has no ventilating openings. Shown in Figures 7 and 8 are two examples of totally enclosed motors that are cooled with different designs. In Figure 7 the cooling of the motor is accomplished by a shaft mounted fan external to the motor and protected by a fan cover. This type of enclosure is representative of the majority of industrial motors. The heat from the stator is dissipated through the radial fins cast into the stator housing.

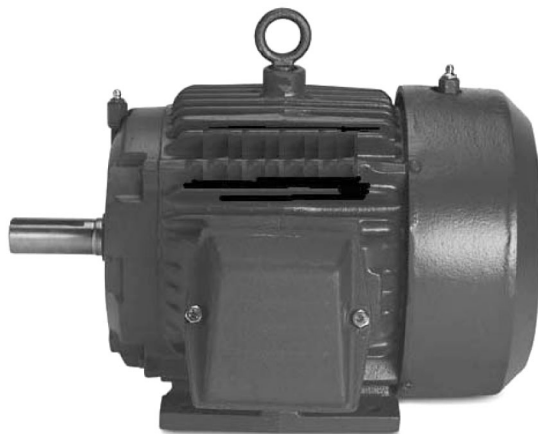

Figure 7. TEFC Motor Enclosure.

Figure 8 is a totally-enclosed-air-over motor. The cooling is similar to Figure 7, except the fan is mounted to a separate motor for continuous cooling air. This motor would be used on a variable speed controller. When the motor speed is reduced for the application, the motor still receives the maximum air flow for cooling. The motors in Figures 5, 6, and Figure 7 would lose their cooling source if the motor speed is reduced, since the fans are mounted to the shaft of the motor.

**NEMA DESIGNS AND TORQUE**

NEMA designs define the torque and current characteristics of the AC induction motor. Letters are used to define the categories.



Figure 8. TEBC Motor Enclosure.

Table 1 lists the four categories and the applications. Torque is the prime consideration in motor application, representing the turning effect developed by the motor or, from the opposite viewpoint, the resistance to rotation exerted by the driven load. The AC squirrel-cage induction motor has four important torques that must be considered. Figure 9 shows a typical speed-torque curve for an AC induction motor with the four critical torques identified.

- Full load torque is the torque required to produce rated horsepower at full speed.
- Breakdown torque is the maximum torque that can be developed by the motor at rated voltage and frequency without a sudden loss of speed. This represents the ability of the motor to maintain operation under peak-load conditions.
- Pull-up torque is the minimum torque developed by an AC induction motor during the period of acceleration from zero to the speed at which breakdown occurs.
- Starting torque is the torque delivered by a motor at the instant it is energized. Starting torque is often higher than rated running or full load torque.

Table 1. Standard NEMA Designs of Various Torque Characteristics to Meet Different Application Loads.

NEMA Design	Starting Torque	Starting Current	Breakdown Torque	Full Load Slip	Typical sine wave Applications
A	Normal	High	High	Low	Mach. Tools, Fans
B	Normal	Normal	Normal	Normal	General Industrial
C	High	Normal	Normal	Normal	Loaded Compressor, Loaded Conveyor
D	Very High	Low		High	Punch Press or Hoists

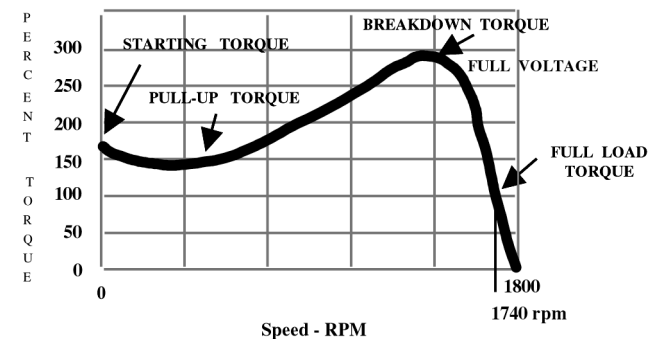

Figure 9. Typical NEMA Speed-Torque Curve for AC Induction Motor.

**MOTOR EFFICIENCY**

Motor efficiency is a measure of the effectiveness with which a motor converts electrical energy to mechanical energy (Figure 10). It is defined as the ratio of power output to power input or, in terms of electrical power, watts output to watts input, and can be restated

as the ratio of output to output plus losses. The difference—watts loss—is due to electrical losses plus friction and windage. Even though higher horsepower motors are typically more efficient, their losses are significant and should not be ignored. In fact, higher horsepower motors offer the greatest savings potential for the least analysis effort, since just one motor can save more energy than several smaller motors.

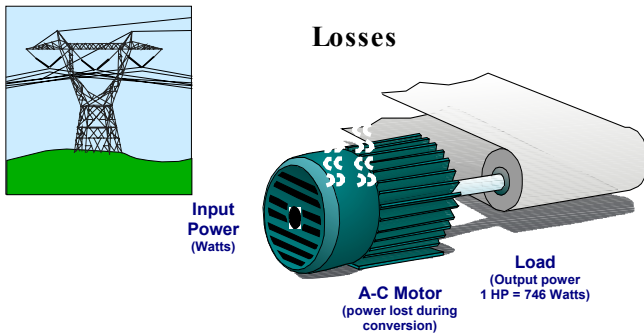

Figure 10. Motor Efficiency/Losses.

Every AC motor has five components of watt losses that are the reasons for its inefficiency. Reference Table 2 for typical losses in a NEMA Design B motor rated 10 hp at 1800 rpm with a totally enclosed frame. Watt losses are converted into heat, which is dissipated by the motor frame aided by fans. Stator and rotor I squared R losses are caused by current flowing through the motor winding and are proportional to the current squared times the winding resistance. Iron losses are mainly confined to the laminated core of the stator and rotor and can be reduced by utilizing steels with low core loss characteristics found in high grade silicon steel. Friction and windage loss is due to all sources of friction and air movement in the motor and may be appreciable in large high-speed or totally enclosed fan-cooled motors. The stray load loss is due mainly to high frequency flux pulsations caused by design and manufacturing variations.

Table 2. Typical Losses in a NEMA Design B Motor Rated 10 HP, 1800 RPM.

Loss Components	Typical Losses (Watts)	
	Std. Eff.	High Eff.
1) Iron	220	104
2) Stator	530	298
3) Rotor	218	192
4) Friction and Windage	71	70
5) Stray Loss Load	131	101
<b>Total</b>	<b>1170</b>	<b>765</b>

The Institute of Electrical and Electronic Engineers (IEEE) Standard 112-1996 (1996) defines five methods by which motor efficiency can be determined. A basic understanding of all five methods is important to understand how the efficiencies are calculated. This will also help in understanding how efficiencies are quoted per different standards. The IEEE test methods are as follows:

Method A (Input-Output)

This method uses a mechanical brake or dynamometer to load the motor from 25 percent load to 150 percent of load in 25 percent increments. Voltage, electrical power in watts, current, load torque, speed, and winding temperature data are monitored and recorded.

The efficiency is determined by the simple ratio of the output power over the input power, after the I squared R losses are corrected to the rated temperature. This method is widely used for fractional horsepower motors because of the heat generated by the brake.

Method B (Input-Output with Loss Segregation)

In this method the motor is coupled to a dynamometer, and rated voltage and frequency are applied. The motor is loaded to a torque equivalent to 25 percent, 50 percent, 75 percent, 100 percent, 125 percent, and 150 percent of rated horsepower loads. Voltage, electrical power in watts, current, load torque, speed, and winding temperature data are monitored and recorded at each point. These data are used to calculate the stator and rotor I squared R losses and stray-load losses as shown below.

- Stator winding I squared R loss (Ws) = 1.5 × Current (squared) × Winding resistance (at rated temperature)
- Rotor winding I squared R loss (Wr) = (Input power – Wfw – Wcore) × Slip (inches per unit)
- Stray-load loss (Wsl) = (Input power – Output power) – (Wfw + Wcore + Wr + Ws)

The stator core loss (Wcore) and friction and windage losses (Wfw) are constant losses that are determined from no-load saturation tests using IEEE method 112-5.3 (1996).

The stray-load loss is calculated for every load point from 25 percent to 150 percent load. However, this will provide stray losses at only the tested load point, and random measurement error for every test point is different. To minimize this random test measurement error, the stray-load loss is corrected as depicted in Figure 11, by shifting the linear regression curve fit line to reflect zero stray-load loss at zero load.

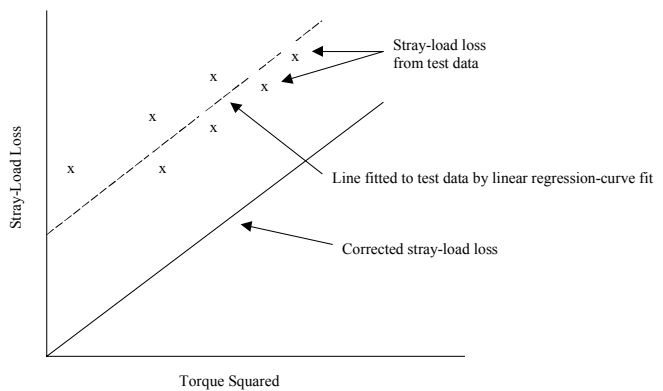

Figure 11. Stray-Load Loss Correction by Linear Regression Curve Fit.

The efficiency is then calculated as follows based on the corrected stray-load loss (Wslc) and all other losses.

• Efficiency = (Input power – (Wfw + Wcore + Ws + Wr + Wslc)) / Input power

Method C (Duplicate Machines)

This method is used when duplicate motors are available. The two motors are coupled together and connected to two sources of power, with the frequency of one source being adjustable. During the test, one machine is run as a motor at rated voltage and frequency, and the other is run as a generator at rated voltage per hertz, but at lower frequency, to produce the desired load. Electrical input and output readings are taken, along with the stator winding temperatures and the speed of both machines. The efficiency is calculated by the loss segregation method.

### Method E (Input Measurement)

In this method the motor is connected to a variable load. The output is determined by subtracting the total losses from the input. As in other methods, to determine the load losses the input power, current, voltage, speed, and temperature readings are measured to determine the stator and rotor I squared R losses. The stray-load loss can be found by a separate reverse-rotation test and a rotor removed test. An alternate method proposed by NEMA/IEEE permits an assumed value for the stray-load loss to be used based on the rating of the motor as shown in Table 3.

Table 3. Assumed Values for Stray-Load Loss.

Motor Rating	Stray-Load Loss in % of Rated Output
1 - 25 hp	1.8%
26 - 500hp	1.5%
501 - 2499hp	1.2%
≥ 2500hp	0.9%

### Method F (Equivalent Circuit)

This method does not require the motor to be coupled to a variable load such as a dynamometer. The motor performance parameters such as efficiency, power factor, and torque are calculated from an equivalent circuit as shown in Figure 12,

where the parameters are defined as follows:

- R1 = Stator resistance
- X1 = Stator reactance
- R2 = Rotor resistance
- X2 = Rotor reactance
- Rfe = Iron loss resistance
- Xm = Magnetizing reactance
- V = Applied voltage

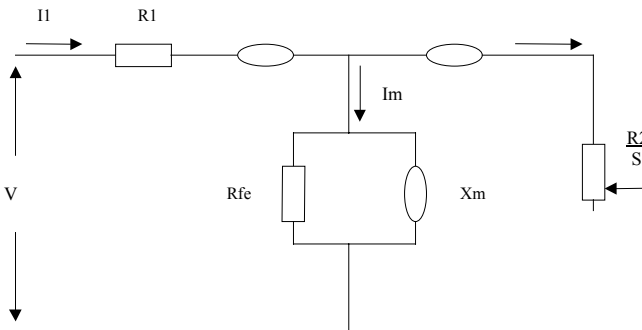

Figure 12. Motor Equivalent Circuit.

This circuit is based on data from no-load saturation tests, locked-rotor tests and impedance tests. The impedance data at operating conditions are determined by three-phase locked tests at 100 percent, 50 percent, and 25 percent of rated frequency, and at rated current. These data are used to determine the rotor and stator resistance and reactance, from which the performance of the motor is determined. The stray-load loss for this test is assumed based on the motor rating from Table 3. Method F is also known as the "short efficiency test" and is sometimes used as an alternate to Method B. Whenever a temperature test is requested along with the Method F efficiency test, the motor will receive a similar load performance as defined in Method B. However, the stray load loss will be assumed instead of using the procedure followed in Method B.

## MECHANICAL DESIGN

### Stator and Rotor

The stator is that part of the AC induction motor's magnetic structure that does not rotate. It contains the primary winding and is made up of laminations with a large hole in the center in which the rotor can turn. There are slots in the stator in which the windings of the coils are inserted.

The rotor is the rotating member of the AC induction motor and is made up of stacked laminations. A shaft runs through the center and a squirrel cage made of cast aluminum or copper bars holds the laminations together. The squirrel cage acts as a conductor for the induced magnetic field. The cast rotor is manufactured as one assembly of bars, end rings, and fan blades. The manufacturing process is controlled to produce a homogenous void-free rotor casting. Casting quality is controlled by using high quality ductile aluminum and proper injection molding techniques. Cast rotors provide three times faster conduction of heat from bars to the laminated core than copper bar rotors. The bars are in direct contact with the core, which allows for faster heat conduction. The rotor fan blades, which are cast integrally with the end ring and bars, provide rapid heat dissipation to the air at the end of the rotor. This characteristic of rapid heat dissipation allows for acceleration of large inertia's without thermal distortion and overstressing of the aluminum rotor cage. A comparison of cast rotors versus bar rotors is shown in Table 4.

Table 4. Cast Versus Bar Rotor Comparison.

	CAST	BAR
Manufacture Cost	Low	High
Bar Shape	Very Flexible	Limited
Bar Material	ONLY AL (55% Cond)	Many Sizes (100-5% cond)
Starting Ability	Excellent (3x faster)	Good
Inertia WK <sup>2</sup>	Low (Appx. 20-30% lower than bar)	Good
Maximum Size	Up to 2000 Hp	No size limit
Tooling Cost - Initial	High	Minimum
Casting Porosity	Yes	No
Repairable	Difficult to Impossible	Possible

### Rotor Ventilation and Cooling

Maximum cooling is provided by proper venting of the rotor core. Two-pole rotors utilize a solid lamination design (no air ducts), which prevents uneven buildup of dirt in the rotor ducts that could result in high vibration levels. The solid lamination maximizes the shaft to rotor contact area, increasing the rotor core stiffness. The rotor is cooled by axial flow of air through the air gap between the rotor and stator. TEFC motors also utilize the solid rotor design. Cooling is achieved by airflow around the end rings and axial flow through the air gap. Heat is removed from the rotor by convection and conduction through the stator core and finned frame. Slow speed rotors (1800 rpm and less) have a ducted rotor core. Radial holes are punched in each lamination to provide airflow through the center of the core for the full axial core length. In addition to the laminations with radial ducts, special spacer laminations are placed at several locations along the axial length of the core. The spacer laminations ensure cool air circulation past the rotor bars and through the stator windings. This design allows a generous flow of air through the center of the rotor core.

### Shaft Construction

Many manufacturers' standard material is hot rolled 1026-1045 (FSCL-I) or 4150 (FSCL-II) steel with a tensile strength of 75,000 to 115,000 psi, respectively. The material strength and shaft size are determined to withstand 10 times rated torque. All shafts are turned and ground to tight tolerances that help eliminate rotor core runout and unbalance of the final rotor assembly. Typical tolerances are as follows:



- 0.50 mil runout at bearing journal
- 20 micro finish on bearing journals

There are basically two shaft designs, the solid one piece and the spider construction (Figure 13). Typically all 3600 rpm motors and all motors rated above 1500 hp utilize a solid shaft (4150 steel), which is stress relieved prior to final turn and grind. Thermal stress relief is performed to relieve internal stresses, improve machinability, and minimize dimensional changes. The American Petroleum Institute (API) Standard 541 (1993) titled “Form-Wound Squirrel Cage Induction Motors—250 Horsepower and Larger,” requires the use of a solid, one piece, heat treated forging for all two-pole motors and all motors operating above the first lateral critical speed. In many cases forgings are available as an option from the motor manufacturer. The spider shaft construction is used on slow speed rotors with large diameters. The spider design eliminates excess material and cools the rotor by allowing air to pass through the spider. Weld stresses are eliminated by a carefully controlled heat treatment and welding process.

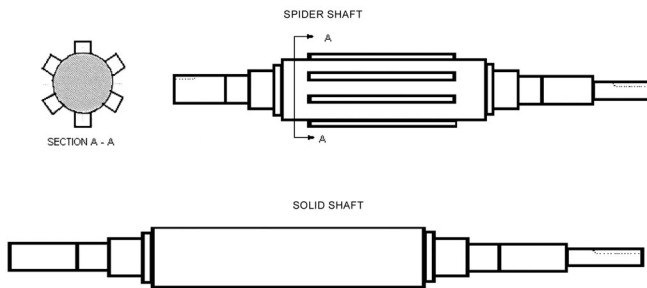

Figure 13. Rotor Shaft Construction Types.

Shaft Assembly by Interference Fit

Not only is it important to produce quality components, but the assembly of the shaft to the rotor must be performed under tightly controlled manufacturing processes. The controlled process produces an assembly with minimal and uniform residual stresses at the rotor to shaft interface. The rotor is heated and assembled to the shaft with an interference fit. The interference fit creates a uniformly distributed force between the shaft and rotor. This force restricts the rotor from spinning on the shaft. For two-pole rotors the interference fit is slightly tighter to increase core stiffness. Two-pole bar rotors are cool wrapped in an insulated blanket. The blanket reduces thermal distortion due to quick and uneven cooling. Cast rotors are less sensitive to thermal distortion and are therefore cooled vertically but without the blanket. All other rotors are cooled without the blanket and in the horizontal position. The assembly is allowed to cool to room temperature before machining the core outside diameter (OD). Uneven air gaps create unbalanced magnetic forces. The magnetic forces are reduced by machining the core.

ELECTRICAL DESIGN

Insulating System

The insulating system within a motor serves two basic functions:

- Separates the various electrical components from one another
- Protects itself and the electrical components from attack of contaminants and other destructive forces

In general five specialized elements are employed that constitute the motor’s insulation system. The following are typical in an AC induction motor:

- *Turn to turn insulation*—This insulation is installed between separate wires in each coil. For smaller motors with random wound

coils, enamel is used as the insulation. On larger motors with form wound coils, taped material is as the insulation.

- *Phase to phase insulation*—This insulation is installed between adjacent coils in different phase groups. On smaller motors with random wound coils, a separate sheet of material is used for this function. On larger motors with form wound coils, tape employed for the turn to turn insulation also performs this function.

- *Phase to ground insulation*—This insulation is installed between the motor windings as a whole and the “ground” or metal parts of the motor. Typically a sheet of insulating material is installed in the stator slots to provide both dielectric and mechanical protection.

- *Slot wedge*—This insulation is used primarily to hold the conductors firmly in the slot.

- *Impregnation*—This process is used to bind all the other insulating components together and fill in the air spaces within the applied insulating materials. This process is applied in fluid form and then cured (hardened) to provide electrical, mechanical, and contaminant attack protection.

Insulation Class

In the past 30 years, the trend in motor construction has been to smaller, higher efficient designs operating at higher temperatures. Improved insulation systems have made these designs possible. In addition, since there are various ambient temperature conditions a motor might see and since there are different temperature ranges within which motors operate, motor insulation is classified by temperature ranges at which it can operate for sustained periods of time without significant loss of insulating life. Today there are four common insulating classes as shown in Table 5.

Table 5. AC Motor Insulation Class (Maximum Total Temperature Range).

Class	AC Motor (1.00 S.F.) Max. Total Temp. Range
A	105 Deg. C
B	130 Deg. C
F	155 Deg. C
H	180 Deg. C

For all practical purposes, Class “A” insulating material has been discontinued for new and rewound industrial grade motors. Class “B” and Class “F” insulation have become the norm with Class “H” being used for special high temperature or inverter duty applications. When a motor insulation class is labeled on the nameplate, the total insulation system is capable of sustained operation at the temperatures listed in Table 5. As a general rule of thumb, each 10°C (50°F) increase in total temperature over the maximum permissible for the motor insulation system halves the life of the insulation.

TYPICAL PUMP APPLICATION CONSIDERATIONS

Horsepower and Torque

The first consideration in selecting a motor for a pump application is determining the horsepower and/or torque requirement of the driven load. The brake horsepower of the pump can be determined from the pump operating curve or from the following formula:

$$BHP = (GPM \times TDH \times SPG) / 3960 \times EFF \quad (3)$$

where:

BHP is the pump brake horsepower

GPM is the flow rate in gallons per minute

TDH is the total differential head in feet

SPG is the specific gravity of the pumped material

EFF is the efficiency of the pump

Generally the first standard motor horsepower rating above the brake horsepower is chosen. Depending on the user's practices, this selection is normally required to be at least 15 percent or more above brake horsepower. This will ensure the motor is sufficient to accelerate the driven load and will ensure the motor can supply sufficient torque continuously at full load. By selecting a motor horsepower above the brake horsepower of the pump, some allowance is made for future pump modifications such as an impeller change or redesign without having to purchase a new motor. In fact it is advisable to select a motor that satisfies the maximum impeller diameter for the pump case. If flow rates need to be increased, the only new investment required would be for the impeller. As can be seen from the pump brake horsepower formula, if the efficiency of the pump decreases, the brake horsepower increases. The pump will then require the motor to deliver more horsepower to maintain the same capacity and head. If the flow rate, the pumps total differential head, and/or the specific gravity of the material being pumped are increased or decreased, a corresponding increase or decrease in loading on the electric motor will likely occur. Any change to one of these process variables should be reviewed in advance to determine the impact on the motor load.

Centrifugal pumps generally do not have an appreciable moment of inertia and, when they are started against a closed discharge valve, the accelerating torque requirements are low. Figure 14 illustrates the typical speed/torque curves for a centrifugal pump.

**Speed - Torque Curve (US Units)**

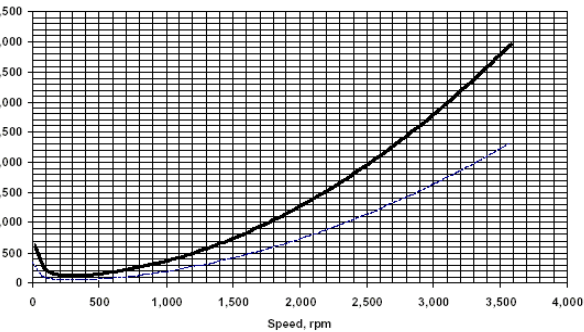

Customer / User	Project	Item No.	Pump
	Pipeline Pump		6 x 8 x 13.5A MSD - 10 Stg
Made By (name)	Date	Sulzer Tender No.	Comments
			Datasheet indicates bp to start again "Cracked" (i.e. our closed valve line).

Figure 14. Typical Speed/Torque Curves for Centrifugal Pump.

The starting torque required by the centrifugal load is approximately 10 to 20 percent of full load. With closed discharge valves, the load builds up smoothly with increasing speed. At full speed, the torque required is approximately 40 percent of full load. The torque requirement then builds up as the discharge valve is opened. At full valve opening, the operating torque and horsepower are at normal levels. If the pump is started with all valves open, the speed/torque requirements must then follow the loaded valves open curve for the pump. Most AC induction motors, if applied correctly, can start the pump for either the unloaded or loaded condition. Centrifugal pumps are comparatively easy to start

because they have a low flywheel effect and low starting torque requirements. Typically a NEMA Design B motor will be applied to a centrifugal pump load. The starting torque of the Design B motor is generally 150 percent of the motor's rated full load torque and remains at or above 150 percent of full load torque until rated full load speed is reached. Refer to Table 6 and Figure 15 for typical performance information on a NEMA Design B motor.

Table 6. NEMA Design B Motor Performance Data.

FRAME	HP	TYPE	PHASE/HERTZ	RPM	VOLTS	
40ST	100	P	3/60	1785	460	
AMPS	DUTY	AMB °C/ INSUL.	S. F.	NEMA DESIGN	CODE LETTER	ENCL.
112	CONT	40/F	1.15	B	G	FCXE
E/S	ROTOR	TEST S. O.	TEST DATE	STATOR RES. @25 °C CHMS (BETWEEN LINES)		
		---	---			
PERFORMANCE						
LOAD	HP	AMPERES	RPM	% POWER FACTOR	% EFFICIENCY	
NO LOAD	0	28.6	1800	5.49	0	
1/4	25.0	39.2	1796	64.3	93.0	
2/4	50.0	59.5	1792	82.5	95.4	
3/4	75.0	84.6	1788	86.7	95.7	
4/4	100	112	1783	87.4	95.4	
5/4	125	141	1778	87.3	94.9	
SPEED TORQUE						
	RPM	TORQUE % FULL LOAD	TORQUE LB. - FT.	AMPERES		
LOCKED ROTOR	0	151	445	725		
PULL UP	360	136	400	706		
BREAKDOWN	1721	250	735	382		
FULL LOAD	1783	100	295	112		
AMPERES SHOWN FOR 460 VOLT CONNECTION. IF OTHER VOLTAGE CONNECTIONS ARE AVAILABLE, THE AMPERES WILL VARY INVERSELY WITH THE RATED VOLTAGE.						
REMARKS: TYPICAL DATA MOTOR DATA-NEMA NOM EFF. 95.4 PCT GUARANTEED M.N EFF. 95.0 PCT						
CR. BY _____ CHK. BY _____ APP. BY _____ DATE _____				A-C MOTOR PERFORMANCE DATA		
				ISSUE DATE _____		

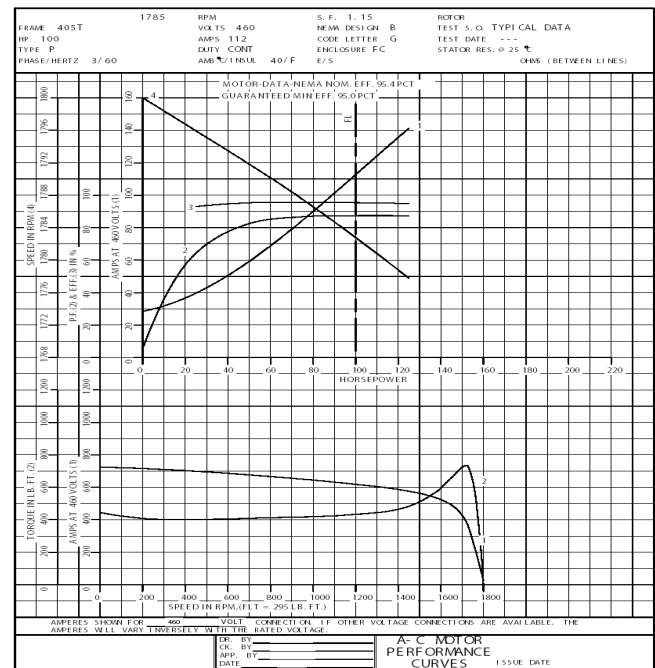

Figure 15. NEMA Design B Motor Performance Curves.

When a pump is connected to long lines of piping, there may be more inertia or static friction in the system than expected. Correct motor selection may require a study of the total system's starting torque needs.

The torque requirement of a constant torque load remains nearly constant over the entire speed range from low speed to full-load speed. Examples of constant torque loads are piston pumps, agitators, rubber mills, and plunger pumps. NEMA Design C motors are generally used for these applications although a NEMA Design B could be used for plunger pump applications if the pump is started unloaded. It is essential that the AC induction motor employed in a constant torque application have torque characteristics that are sufficient to start and accelerate the load to full speed.

#### *Other Considerations*

There are a number of other issues to consider in addition to the horsepower and torque requirements when selecting a motor for a pump application. Energy usage can be a significant cost factor particularly for large horsepower motors that operate continuously. It is advisable to select a high efficiency or premium efficiency motor to reduce the electrical energy usage. Bear in mind that most motors are most efficient when operating at 75 percent full load. This energy cost component is often overlooked as part of the total cost of ownership of the motor installation.

The bearing type specified in a motor is another important application consideration. Motor bearings are either antifriction type or sleeve type. Antifriction type bearings are normally lubricated with grease. Most NEMA frame motors (0.5 to 250 hp) are specified with antifriction bearings. Direct coupled application for motors in this horsepower range is typically antifriction ball bearings. Belt drive applications would typically employ antifriction roller type bearings due to the overhung load. NEMA frame motors are usually low voltage class (600 volts or less). Medium voltage motors (rated 2300 volts or higher) can be specified with either antifriction or sleeve bearings. Sleeve bearings are oil ring lubricated. Medium voltage motors above 700 hp, which operate at 3600 rpm, are normally specified to have sleeve bearings. Motors equipped with sleeve bearings do not have a built-in thrust protection when starting or stopping. Therefore, the total axial end-play of the motor shaft between the two motor bearings is usually 0.5 inch. A limited end float coupling successfully prevents thrust from being transmitted to the bearings of the motor because the maximum end float inherent to the coupling is less than the total axial end-play of the motor. Self centering couplings with semirestricted end-play may be used without modification when limited end float couplings are specified. The most popular of the self-centering coupling is the laminated disc type. The pump installation should be aware of the bearing type options when a motor is being selected.

The voltage rating and the enclosure type are other concerns that should be addressed when selecting a motor for a pump application. The voltage rating selected is largely determined by the available electrical supply source rating, but the cost of the medium voltage equipment to start and control the motor can be substantially higher in comparison to the low voltage equipment for the same horsepower rating. Consider all cost options before a final selection is made. The motor enclosure choice will generally be determined by the electrical hazards classification and the environment of the area where the motor and driven equipment will be installed. While the majority of electric motors are installed in general purpose areas with only moderate concern for contamination from the surrounding environment, electrically hazardous areas and environmentally contaminated areas do exist. In these applications, the motor may require an enclosure that is suitable for the hazard class or environment. For example, if the area hazard class is designated Class I, Division 2, the motor would be required to be TEFC and have a UL label for hazardous duty.

## COMMON FAILURE MODES

### *Mechanical*

A 1985 major energy research consortium study of 6000 utility industry motors indicated 53 percent of motors fail due to mechanical reasons. The failure distribution was as follows:

- Bearing related = 41%
- Stator related = 37%
- Rotor related = 10%
- Other = 12%

Bearing problems are the primary cause of motor failure. One bearing manufacturer estimates 95 percent of all bearing failures can be classified as premature. L-10 bearing life is limited to material fatigue endurance only. Many bearings in service never achieve their L-10 life. Numerous factors have a profound effect on the actual life of a bearing. These factors are as follows:

- Contamination = 45% to 55%
- Lubrication = 11% to 17%
- Improper assembly = 11% to 13%
- Misalignment = 10% to 13%
- Overloading (application) = 8% to 10%
- Other = 1% to 6%

Contamination is the leading cause of premature bearing failure. Even totally enclosed motors “breathe.” The motor bearings rely on the enclosure design, shaft seals, and the grease itself to serve as barriers to contaminant entry. Lubrication is key to bearing life. Bearing life is only as good as lubricant life. All but sealed bearings used in smaller motors require relubrication during their service life.

### *Electrical*

The most common causes of electrical winding failures in motors are due to overtemperature or overload conditions. Other factors such as supply voltage variation, single phasing, improper or poor electrical connections, vibration, and insulation contamination can also contribute, but the majority of the winding failures are attributed to excessive temperature or loading conditions. Assuming the motor is sized adequately for the application, overtemperature conditions are typically caused by restricted ventilation. This may be due to air passages being blocked due to dirt, oil, or some other contamination. For larger horsepower motors, the air filters may be plugged or dirty. The physical location of the motor may be such that air inlets and outlets are blocked or restricted. Whatever the reason, the thermal life of the insulation will be severely reduced unless the overtemperature condition is eliminated. Larger and/or critical motors generally have overtemperature monitoring and protection to prevent prolonged operation of the motor under high temperatures.

The other primary cause of electrical winding failure is overloading the motor. Often this condition results from changes in the driven equipment load requirement. A process change requiring different temperature, viscosity, or concentration can manifest itself in higher horsepower demands on the motor. A new pump, fan, or compressor or modification to the driven equipment can present an increased starting or continuous load demand on the motor. Over time the overload condition will manifest itself in higher temperatures on the motor winding insulation. Prolonged high temperatures in excess of the insulation thermal rating will lead to premature winding failure. For larger horsepower motors, above 250 hp, too frequent starting can result in rotor and winding failures due to excessive heat generation.

### *Misapplication*

Sometimes electrical failures occur in motors due to misapplication. While there are many common features to most motors, not all motors are created equal in capability. It is essential to understand the torque requirements of the driven load. This is necessary to confirm the motor can start the load, accelerate the load to rated speed, and supply torque within its rating.

Misapplication often occurs because of the failure to fully understand and define the load requirements of the driven equipment. Consultation with the driven equipment manufacturer is appropriate if there are any questions on the load requirements. Misapplication sometimes occurs when a motor is moved from one service and is employed in a different service. This situation again requires some diligence by the user to verify the load requirements of the new service and to verify the design characteristics of the motor that is to be redeployed. Consultation with both the motor and the driven equipment manufacturer would be appropriate in this situation.

## CONCLUSION

By now it should be clear that motors have some unique design characteristics that should be taken into consideration before any application decision is made. There are essentially four major requirements necessary for the selection of the proper motor. These requirements are as follows:

- The motor must be capable of starting the driven load from rest.
- Acceleration to full speed must be attained without injury to the motor or the load.
- Full load must be supplied in accordance with the required duty cycle and demands of the driven equipment.
- Capacity should be available for temporary or short-term overloads.

Adherence to the above criteria will make a significant contribution to the successful application and long term reliability of AC induction motor installations.

## REFERENCES

- 2002 National Electric Code®, 2002, National Fire Protection Association, Quincy, Massachusetts.
- API Standard 541, 1993, "Form-Wound Squirrel Cage Induction Motors—250 Horsepower and Larger," American Petroleum Institute, Washington, D.C.
- Institute of Electrical and Electronic Engineers Standard 112-1996, 1996, "Test Procedure for Polyphase Induction Motors and Generators," Washington, D.C.
- NEMA Standard Publication MG-1, 1993, "Motors and Generators," National Electrical Manufacturers Association, Washington, D.C.

## BIBLIOGRAPHY

- Del Toro, V., 1968, *Electromechanical Devices for Energy Conversion and Control Systems*, Englewood Cliffs, New Jersey: Prentice-Hall.
- "Proper Motor Lubrication," December 1987, *Engineer's Digest*, Rockwell Automation, Reliance Electric White Paper, Document B-5021.
- Traister, J. E., 1984, *Handbook of Electric Motors: Use and Repair*, Englewood Cliffs, New Jersey: Prentice-Hall.
- Westinghouse, 1974, *Westinghouse Electrical Maintenance Hints*, Trafford, Pennsylvania: Westinghouse Electric Corporation.
- "What Do All Those Things on an AC Motor Nameplate Mean?" May 1993, *Power Transmission Design*, Rockwell Automation, Reliance Electric White Paper, Document B-7095-1.