



ORIGAMI FROM AROUND THE WORLD

VICENTE PALACIOS

**ORIGAMI
FROM AROUND
THE WORLD**

VICENTE PALACIOS

DOVER PUBLICATIONS, INC.
Mineola, New York

Copyright

English translation copyright © 2002 by Dover Publications, Inc.

Origami from Around the World was originally published in Spanish in 1998 as *Papiroflexia selecta*, © 1998 by Vicente Palacios

All rights reserved under Pan American and International Copyright Conventions.

Partial or total reproduction of this work in any language, without the written permission of the original publisher, whether by printing, by photocopying, in micro form, or by any means, is prohibited.

Bibliographical Note

This Dover edition, first published in 2002, includes all diagrams and illustrations from pages 15–177 of *Papiroflexia selecta*, originally published in Spanish in 1998 by Editorial Miguel A. Salvatella S.A., Barcelona, Spain, as well as an English translation of all text on those pages. The Dover edition also includes a Contents listing in English, as well as English translations of the author's Preface, his notes on selected origami models included in the book, and the alphabetical list of all origami models presented. Some of the diagrams in the book originally were published in *Papirologami*, a book in Spanish originally published in 1972 by Editorial Miguel A. Salvatella S.A. This Dover edition is published by special arrangement with Editorial Miguel A. Salvatella S.A.

International Standard Book Number: 0-486-42222-4

Manufactured in the United States of America
Dover Publications, Inc., 31 East 2nd Street, Mineola, N.Y. 11501

CONTENTS

- Paper Folding 5
- Some of the Figures on the Following Pages 9
- Symbols 11
- Models
- Clicker and Its Variant 13
 - Feather for Cap 14
 - Hat and Legionnaire's Cap 15
 - Pitufo 16
 - Girl's Dress 17
 - Vase 18
 - Cap 1 19
 - Cap 2 20
 - Winged Cube 21
 - Boat 22
 - Box 23
 - Centerpiece for Table 24
 - Sparrow 25
 - Modular Cube (1) 26
 - Modular Cube (2) 27
 - Modular Cube (3) 28
 - Modular Cube (4) 29
 - Little Bird Bookmark 30
 - Celtic Helmet 31
 - Airplane 32
 - Little Terrier Dog 33
 - Pentagon and Dodecahedron 34
 - "Tato" Wrapper (traditional Japanese) 35
 - Dove 36
 - Heart for a Drinking Glass 37
 - Boat 38
 - Bird's Perch 39
 - Rowboat 40
 - Stand for Cards, Photos, etc. 41
 - Sailboat 42
 - Parrot 43
 - Bird in Flight 45
 - Condor 46
 - Buzzard 47
 - Bird 48
 - Five-Sided Box 49
 - Frog 50
 - Muslim Praying 51
 - Stork 52
 - Crystal 54
 - Cubic Box 55
 - Persian Slippers 56
 - Hello, Hello! 57
 - Five-Point Modular Star 58
 - Five-Point (or Six-Point) Star 59
 - Acid Lemon 60
 - Yacht 61
 - Jug 62
 - Whistle That Whistles 63
 - Capercaillie (bird) 64
 - Irreversible-Process Box 66
 - Modular Crown (1) 67
 - Modular Cross 69
 - Modular Crown (2) 70
 - Simple Box 71
 - Houseboat 72
 - Goldfish 73
 - Modular Ditetrahedron 74
 - Eagle 76
 - Snail Shell 78
 - Trough with Cranes 80
 - Two-Seat Boat 82
 - Chinese Junk 85
 - Plant in Flowerpot 87
 - Lohengrin's Swan 88
 - Truncated Cube 89
 - Box with Handles 90
 - Young Dutchwoman 92
 - Rabbit 94
 - Camellia 96
 - Fish That Opens and Shuts Its Mouth 98
 - Me and My Shadow (Cats) 100

Little Bird in Boat	103	Elephant	132
Decorated Box	105	Bear Cub	134
Interlocked Hexagons	106	Little Dog (2)	137
Little Dog (1)	107	Horse	139
Buddha	109	Meeusen-esque	142
Swan	111	Waterwheel	145
Wilfred's Crown	112	Weasel	148
Seven-Module Crown	114	Interweavings DZ-20A and DZ-20B	150
Eight-Module Star (1)	115	Eight-Module Star (2)	152
Pinwheel	116	Bowl or Open Receptacle	155
Wreath	117	Geisha	157
Hexagon	119	Biplane	161
Star 1	120	Armor	164
Star 2	121		
Knickknack	122	Some Origami Associations	174
Five-Point Star	125	Alphabetical List of Models	175
Little Whale	127		
Boxer Dog	129		

PAPER FOLDING

Paper folding is the art, and therefore the creation, of figures with a recognizable meaning, by means of geometric folding of a sheet of paper that preferably is square. By saying “geometric,” I want to indicate that the genuine fold in origami is the *fixed* fold, the fold between fixed points—for example, the fixed division of an angle in half.

This art is given various names in different countries. The most widespread name internationally is the Japanese *origami* (from *ori*, “to fold,” and *kami*, “paper”), but it very commonly is called *Papierfalten* in German, *carta piegata* or *piegatura della carta* in Italian, *papiroflexia* in Spanish, *pliage de papier* in French, *papiervouwen* in Dutch, etc., all of which have the same meaning.

Paper folding gets its basis in the West in the idea of creating something from nothing. Obviously we cannot create something from nothing, but we can create something from almost nothing. So we can start off, as we are going to see, with a minimum of resources accessible to everyone, and create with them the figures that occur to us and, of course, so much the better, the more ambitious, ingenious, and original they are.

The Paper: The flat surface has been considered, since ancient times, the most similar to nothing in the world of forms. Paper, because it is economical, abundant, and accessible, is considered the material singularly apt for use in paper folding. The perfection and variety with which it can be manipulated satisfies the most demanding person.

White paper makes folds and forms stand out as no other paper does, and for this reason it tends to be used very much in paper folding, but the charm that color supplies also is very important. Very frequently we use bright-color papers, or paper of a color chosen according to the meaning of a specific model.

The Initial Form: As the object of this art is the creation of something by means of a minimum of resources, it is natural that the initial form of the paper used should be the simplest, that is, square. It may be argued that the circle or the equilateral triangle is simpler, but though that may be so in theory, it is not so in practice. To obtain a sheet of paper circular in form, it would be necessary to use a compass and a pair of scissors, which would complicate our work quite a bit from the very beginning.

Of course, it is possible to create some figure from a sheet of paper in any form. The goal here is to establish some thought-out or commonsense norms that comprise the purest essentials of paperfolding. That doesn't mean that we dislike the creation of figures from other forms of paper, at least those that also are very easy to obtain. The norms need not be entirely the most purely orthodox, but by being close to that, they will merit our interest and appreciation.

Cutting: Obviously this is excluded, because it requires a resource that is totally unnecessary. Unamuno warned that with such a resource, the figure obtained would not actually proceed from the flat surface. “Fold and fold only!” is the motto, and “the creative possibilities of a sheet of paper are mathematically infinite” (Dr. Isidro Gomá).

The Folding: Folding is the least transformation that we can apply to a sheet of paper, but all kinds of folds are not equally good in principle. Arbitrary folding is permitted if it is not overused. The overuse of arbitrary folding detracts interest from a figure, and even its own creator would not be able to make it again the same way, without taking measurements to make each fold. The genuine manner of folding in paper folding is, as we have said, the *fixed* fold.

Simultaneous Folding: This is what we call two or more folds that should be made at the same time. These sometimes are a nightmare for the beginner, but they involve true charm for the expert. Mr. Dokuohtei Nakano used to, in such cases, fold one by one each fold of the group, and then proceed immediately, after such preparation, to the simultaneous fold. At the opposite extreme was Adolfo Cerceda, for example, and much more so Mr. Shuzo Fujimoto; to see them fold was absolutely spectacular. At the 1988 convention in Verona, it was impossible for us to follow Mr. Fujimoto's folding, because he folded with all ten fingers at the same time! Fortunately for the self-confidence of hobbyists in general, these are very exceptional artists.

Folding As a Process: This in itself is of great importance. The folding must constitute an authentic metamorphosis of the paper. It must absolutely avoid the artificial and the devilishly difficult. It must hide its goal, to make the result more surprising with the enchantment of the unforeseen.

A process of folding in which, without using scissors, we need a pencil compass, a ruler marked according to the metric system or the U.S. system, and a protractor, is outside of the traditional and genuine line of our art, of which Ramón Gómez de la Serna wrote, "engaged in on a tabletop, while one is thinking of so many fleeting things, it's something indescribable." (*Variaciones*).

Which is preferable: a simple model, or a complicated model? If by simplicity we mean a small number of folds, the difference doesn't matter, but if we mean naturalness as opposed to artificiality, certainly we prefer the simple model.

The Finished Model: Obviously a three-dimensional model is superior, in principle, to a flat model. The compact or rigid model is superior to the model that seems to be made only to be seen from a distance or that unfolds by itself. A figure is superior inasmuch as it technically and artistically better reproduces the object that it represents. Among animal figures, the one that stands firmly on its feet is superior, in principle, to the one that can be stood up only with difficulty or not at all. A quadruped with three paws, or an insect with four, is a lamentable thing, besides. The model that requires a greater creative vision is superior; so is one that has more and better variants; and so is one that has had greater influence on the evolution of our art. The model is superior that embodies in its development, or in the specific features of its final form, ideas that are more original or of greater interest.

To begin creating, one can try to create a bird, which in itself requires only the four corners of the sheet of paper, or one can try a variant of a modular cube, which doesn't demand much knowledge nor much experience. Once we have gotten started, though, we should avoid "reruns," that is, trying to create what already has been created repeatedly, though in the process of folding we may have followed a somewhat different path. It is hard to know who created some figures, because they look very similar to some others. We should try to be authentically original, striving to create something new and really ingenious.

The use of hidden wires, mucilage, adhesives, etc., to give a figure body is sadly unworthy of a good paper folder and of her or his work, even if it is quite acceptable in the hands of, let's say, a show-window artist or an interior decorator.

Clearly a model can be outside the most genuine and representative line of our art, because of contradicting one of the main norms, and be, nevertheless, a masterly piece in one or more specific aspects, in which case it will merit all of our appreciation and admiration. I tend to comment in such cases, "At this moment science has achieved this! It remains to be seen, now, who may improve it by means of a procedure completely orthodox."

In a flat figure, we should not take care only with the side that is meant to be uppermost. It will be much better if both sides are good, though they may not be exactly the same. A flat figure that only has one good side reminds us of a stage set.

We think that, given what has been said, the reader will have no doubts about the authentic meaning of our art, which if it didn't exist would have to be invented. The reader will be able to consider for herself or himself, in practice, the objective value of the models presented in this book.

A question very common among beginners is what type of paper is the best for paper folding. The first thing that we must verify is whether we are able to complete the folding of the figure in question. Next we will have to ask ourselves what type of paper, what size, what color, will go better with such a figure for a better effect. A paper that very well suits one figure possibly will suit another very badly. Each figure tends to require one type, or some types, of paper and not others.

To fold, for example, a bird in flight, it would be a bad choice to use a thick and rough paper like blotting paper, because surely we wouldn't be able to make the model work, and the paper would tear. In principle a paper rather thin, and smooth, would be advisable.

In our hobby, as in any other, it is very desirable to join with other enthusiasts, so that all can learn from each other.

In the case of folding some modular cubes, it would be advisable to use glossy paper, of very intense and pretty colors, so that they contrast with each other, and it would be in principle very inadvisable to use paper of pale or dull colors. Sheets of paper four inches square will give us good results, if the folding is done properly.

It commonly is said that there is no accounting for tastes. Obviously each person may have her or his own opinions, and it may be that what seems fine to one person will seem undesirable to someone else. That, however, does not prevent the hobby from having its general norms.

Paper folding offers a very varied field of activity to its practitioners. There are people who prefer to create or fold simple figures, and there are those who prefer more complicated ones. There are those who enjoy folding boxes and those who prefer animal figures. There are those who like creating or folding modular figures and those who detest them. Not only that: there are true klutzes who as creators have brilliant ideas and there are fine folders incapable of creating the idea for a figure. The hobby, besides, requires very diverse activities. There are those gifted as organizers, or as directors, or as designers, or in giving classes, or in doing research, or in recording and reporting news of what happens within the hobby.

There are those who specialize in the creation of the most pure and complicated geometric figures and those who prefer action figures, or folding flowers, or hearts.

It is very natural that those who engage in the same specialty relate to each other especially. It would be absurd if, because one is expert in a specialty, one were to disdain those who are expert in others or in none. Everyone needs everyone else. Whoever gathers much information, whoever has an extensive acquaintance, whoever knows other languages, whoever is especially talented or creative in one area, can be

of enormous help to others who are perhaps gifted with other talents or especially interested in other aspects of the hobby.

There are those who, like Mr. Lluís Valldeu, exercise their abilities to inconceivable extremes. He has folded a Little Bird a foot high, a Kawasaki Rose in its most complicated form, more than eighteen inches in diameter, and a Cat of 10,375 modules, and he has done all of that while organizing enormous paper folding exhibitions, including two simultaneous exhibitions.

Those who do not have much of an idea of what paper folding is tend to ask, "What is paper folding good for? Perhaps they would find it difficult to answer if someone asked them, as Benjamin Franklin once asked, "What is a newborn child good for?"

Paper folding is good for exercising one's creativity, ingenuity, and abilities. It is good for having the pleasure of folding and of contemplating what has been folded. It promotes pacifism and is not a classist hobby. It is a good remedy for loneliness. It is good psychomotor exercise for people with some kinds of illnesses. It enables making a multitude of decorative objects or gift items for those who appreciate the fruits of ingenuity. In schools it is good for learning geometry and learning about art in general. It is good for gaining a multitude of friends. It promotes learning other languages and knowledge of design.

It would be interesting to ask ourselves if, objectively, paper folding is not good for more than putting a lot of balls through baskets or scoring many goals, or smoking packs of cigarettes, or scaling mountain peaks, and a long list of other things to which perhaps much importance is conceded and which we don't attempt to question here. "Instead of idiotic parlor games," the Nobel Prize winner Miguel Ángel Asturias wrote to me in 1973, "why not encourage people to become engaged in this marvelous adventure?"

To fold a figure following some diagrams always requires an effort, and more so, clearly, if the figure is complicated and we don't have enough practice. It may be that we will not pay enough attention to some detail or some symbol, or that we will misinterpret some drawing. This happens, at times, even to the most expert person, and especially if the drawings are not very accurate. The effort to obtain the best results is an exercise that always is very useful to utilize and improve our faculties. Of course, if in spite of all our efforts, we don't manage to fold a figure well, we need to leave it for another attempt on another occasion, or to consult another paper folder. At times we trip up with something that someone else sees very clearly—and vice versa!

The diagrams, with the instructions for folding the figures, have been arranged starting with the simplest, and ending with those that require a greater effort.

VICENTE PALACIOS

SOME OF THE FIGURES ON THE FOLLOWING PAGES

Acid Lemon (page 60). Mr. Jack Skillman was folding a yellow sheet of paper when he came up with this figure. Immediately he thought of a sickly-looking lemon that had not ripened. It only was published once (in the United States), but in those diagrams a serious error was made.

Two-Seat Boat (page 82) and *Chinese Junk* (page 85). We see how the Two-Seat Boat traditionally is folded—at least in Spain—and how the well-known Chinese Junk traditionally is folded in Japan. Obviously, this basically is a case of the same creation and of the same origin. The folding of the Two-Seat Boat faithfully reproduces—in my judgment—how this figure should be created and how it has been folded from the beginning. The way in which the Chinese Junk traditionally is folded in Japan seems to be a process developed later, and perhaps from a figure already folded, with total lack of knowledge of the genuine process of its creation and folding. Perhaps whoever initiated this procedure in Japan intended to reduce the number of steps by means of a quite-original process. The procedure worked out and used until then for folding this figure, which certainly was magnificent, was relegated to oblivion.

Boxer Dog, Elephant, Bear Cub, Little Dog 2, Horse (pages 129 to 141). It is very admirable how Mr. Juan López Figueroa discovered this basic fold and this procedure, which enables obtaining a great variety of quadrupeds. Here we present a good sampling of such possibilities. What racking of the brains some figures of this kind would have required for so many other creators!

Meeusen-esque (page 142). Mr. Jeff Beynon took as his starting point, in creating this figure, a procedure used by Mr. José Meeusen. Because of a certain resemblance to some creations of his, he named the figure after him.

Waterwheel (page 145). Mr. Fred Rohm called this “Christmas Decoration.” It seems to me more natural to call it “Waterwheel,” for two reasons. First, because of its resemblance to a waterwheel, with the same design on both sides. In the second place, because I don’t know of any other waterwheel in folded paper, while the name “Christmas Decoration” is generic and doesn’t describe the specific figure.

Geisha (page 157). The most beautiful Japanese papers for origami are ideal for folding this attractive figure, so well done.

Biplane (page 161). Mr. Momotani always carries in his pocket some thin little papers, square, with a metallic coating on one side, the color of old gold. With them, and the tips of his fingers, he folds to perfection this and others of his little airplanes, in which one does not know what to admire more, the vision he has of the folding of such figures, or the exquisite perfection of their folding, which is a little complicated because of some arbitrary folds.

Muslim Praying (page 51). Mrs. Natividad Sánchez Ferrero created this in Larache, in 1926, upon observing Muslims complying with their prayer duties prescribed in the Koran. She folded it in distinct variant forms, and what was most difficult for her to invent, she told us, was the head.















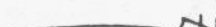

Little Bird in Boat (page 103). In my judgment, this improves upon a previous creation of Mr. Juan Gimeno, based in its turn on a famous boat by Mr. Martin Wall.

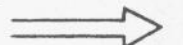
Wilfred's Crown (page 112). Mr. José Meeusen identifies his models by the date when each one was created. He has invented so many! In this case he dedicated one date's figure to Mr. Wilfred Beynon, father of Mr. Jeff Beynon, as it was the date when the former died.

Modular Crown I (page 67). At the Origami USA convention in New York (June 1997), a group of women wore on their heads some pretty and varied modular crowns. At the request of one of those women, Miguel Ángel, my son, conceived and folded right there these that we present here.

Armor (page 164). By now, to compose figures from several pieces of folded paper is nothing new, but in 1992 the well-remembered Mr. Issei Yoshino caused a sensation with his famous Tyrannosaurus Rex Skeleton, folded from 21 square papers, all of the same size. This inspired Mr. Francisco Caboblanco to create this elegant suit of armor.

SYMBOLS

	Valley fold
	Mountain fold
	Fold forward
	Fold backward
	Fold forward and inside
	Fold backward and inside
	See-through view
	Crease left by a fold
	Sink, squash Cut
	Unfold
	Fold and unfold
	Pleat-fold
	Fold over more than once
	Repeat the fold as many times as there are perpendicular lines (in this case, once)
	The following diagram is enlarged
	Division into two equal parts
	Turn the figure upside down
	Reference point

CLICKER AND ITS VARIANT

Traditional

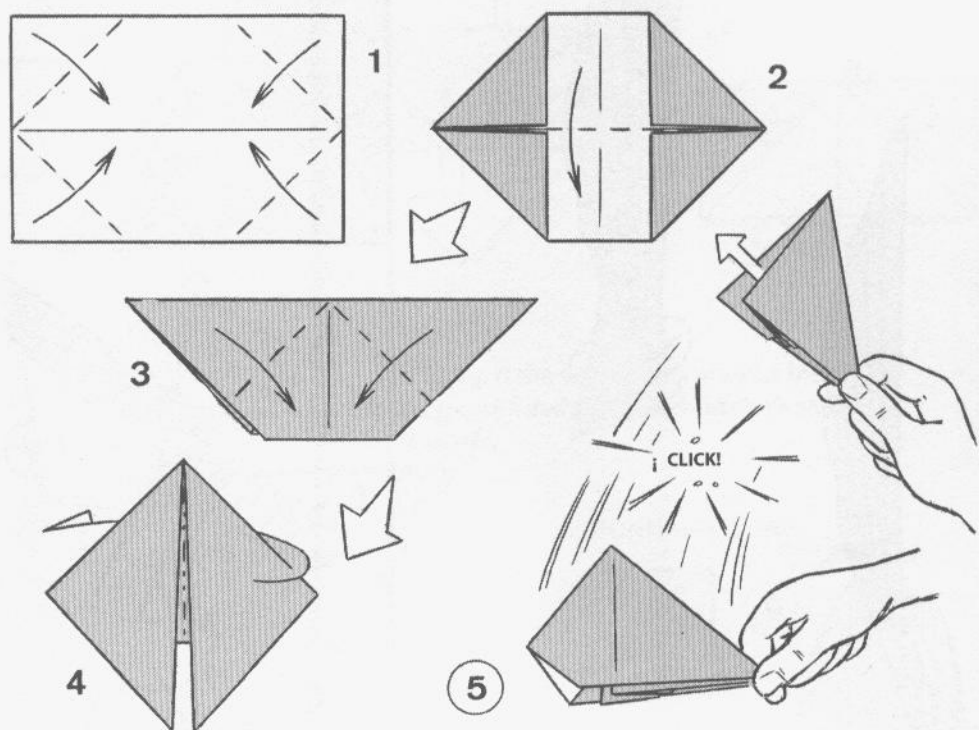
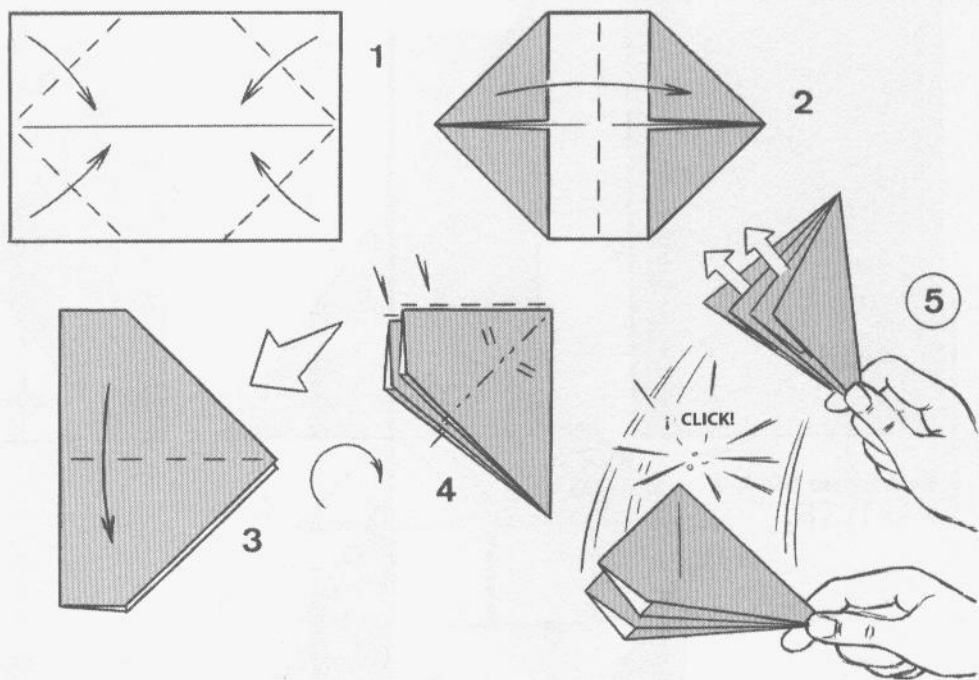

FEATHER FOR CAP

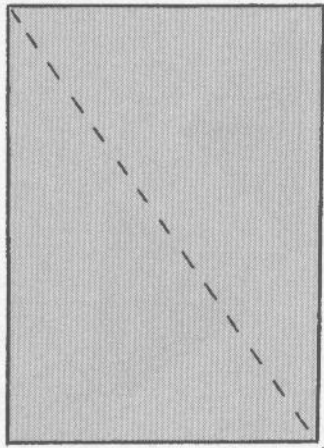

1

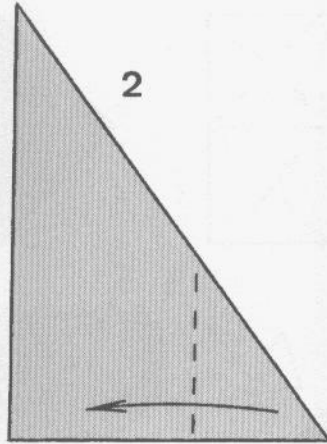

2

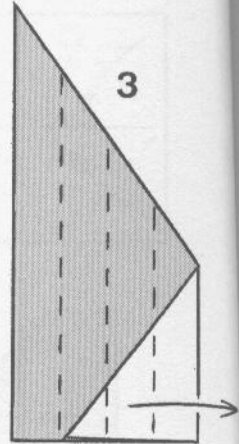

3

Best to use Din A-4
8 1/4 x 11 1/2 in.

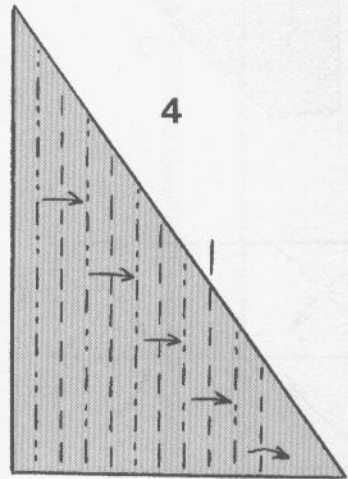

4

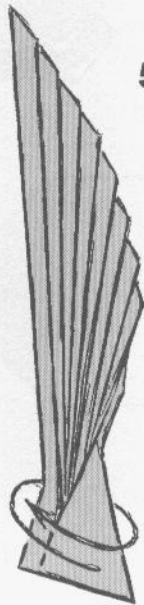

5

6



7

HAT

Traditional

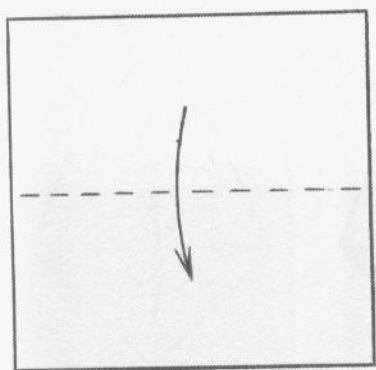

1

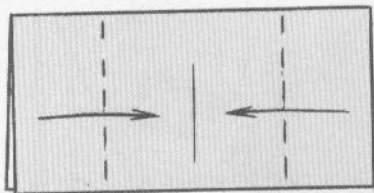

2

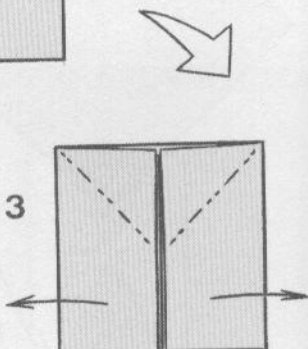

3

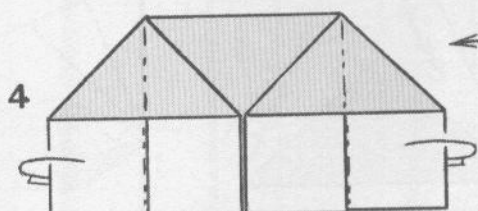

4

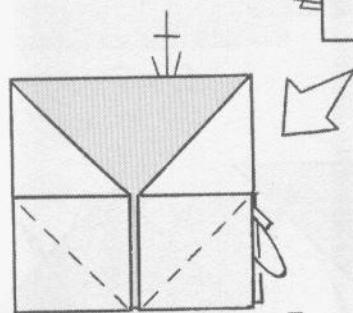

5

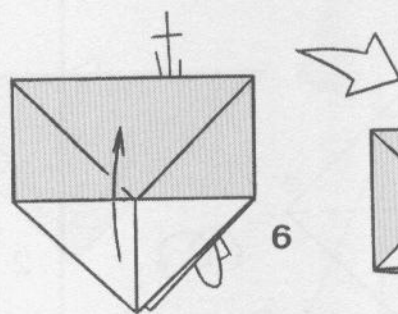

6

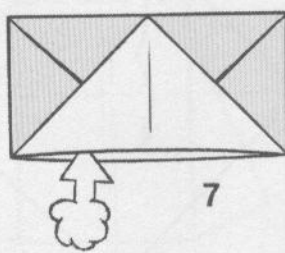

7

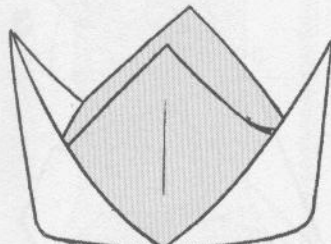

HAT (8)

If in fig. 6 the two points are put inside (and unfolded), the legionnaire's cap is made.

LEGIONNAIRE'S CAP

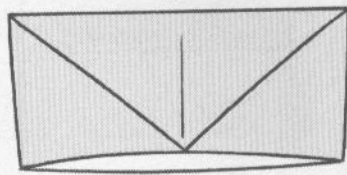

(9)

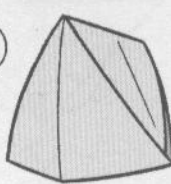

"PITUFO" (comic figure)

by Susana Arashiro

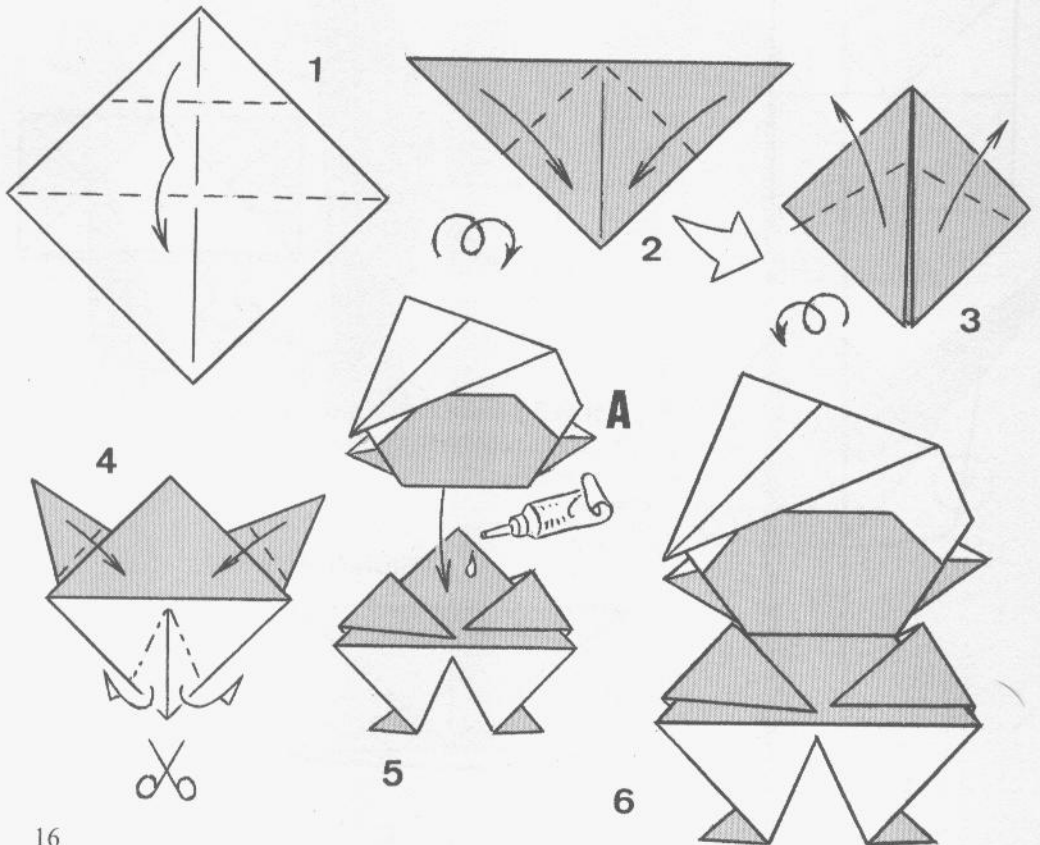
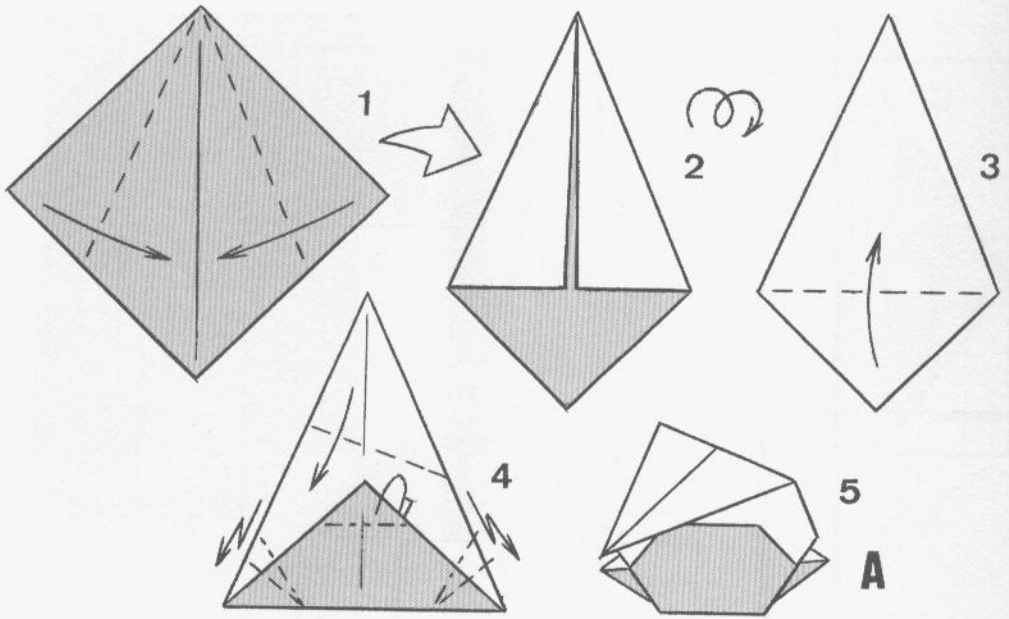

GIRL'S DRESS ("billfold")

by Susana Arashiro

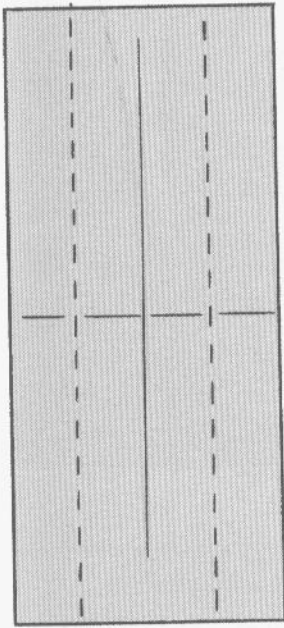

7 x 3

1

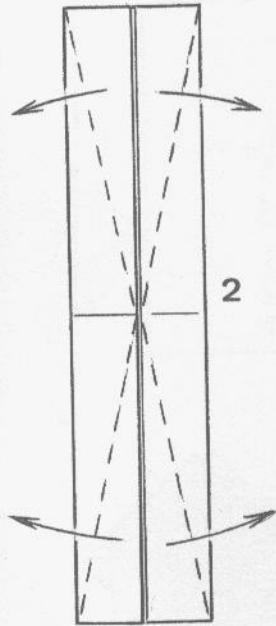

2

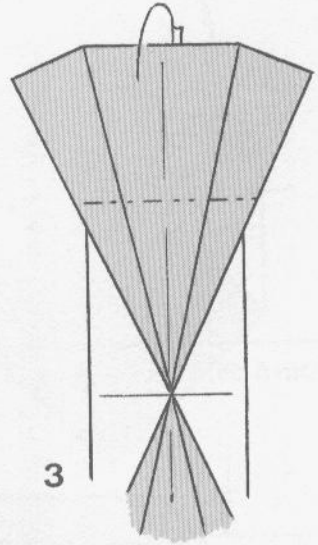

3

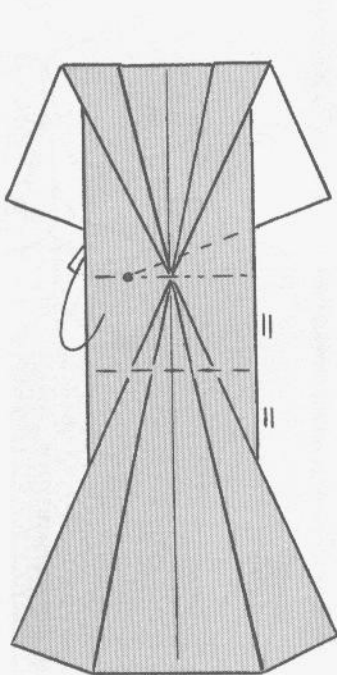

4

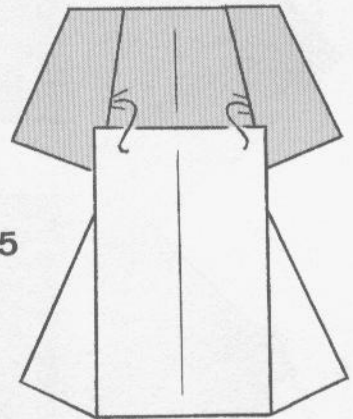

5

6

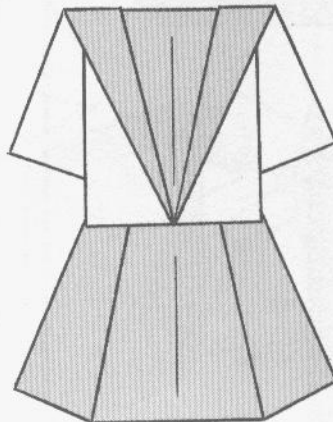

It's good to make this figure with floral paper and bright colors.

VASE

by Luis Valdeneu

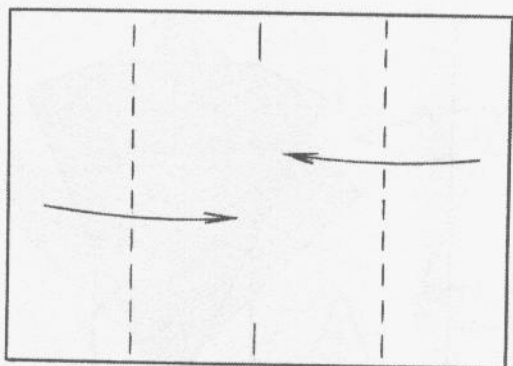

Din A-05, 8 1/4 x 5 1/4 in.

1

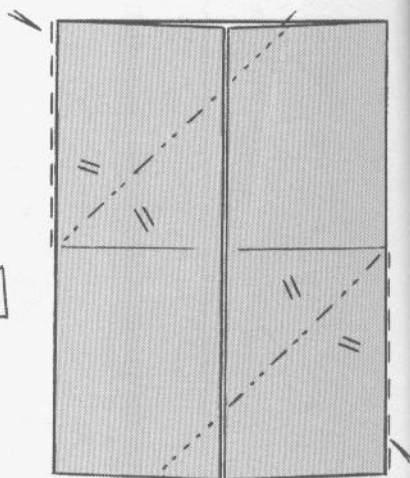

2

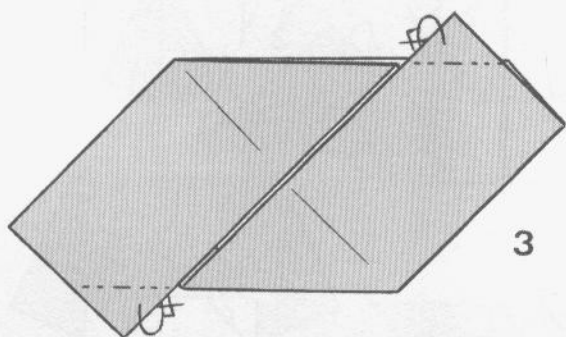

3

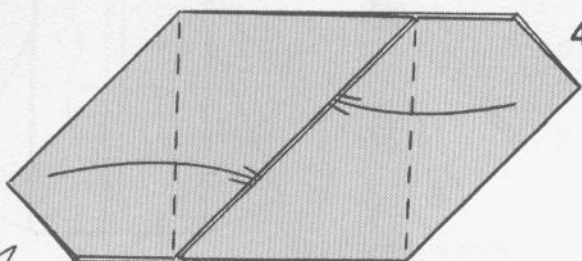

4

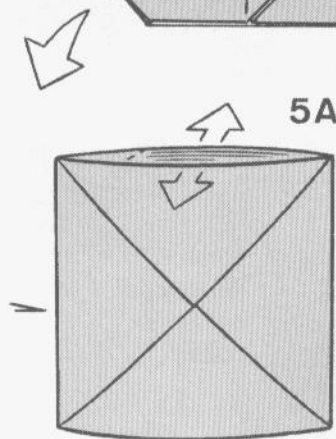

5A

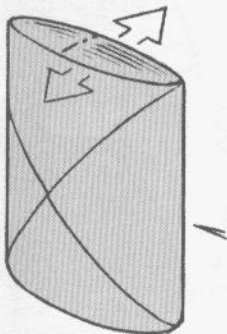

5B

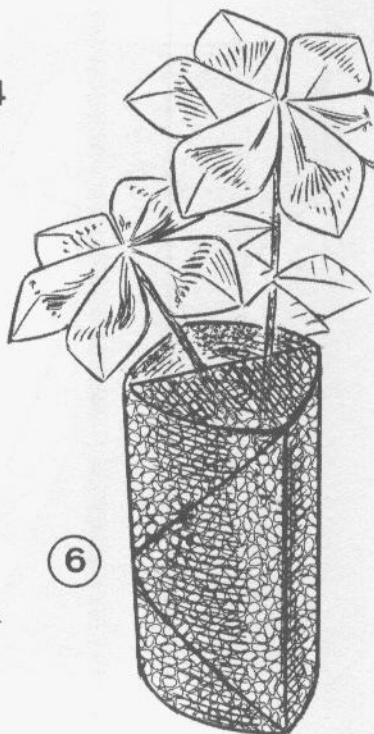

6

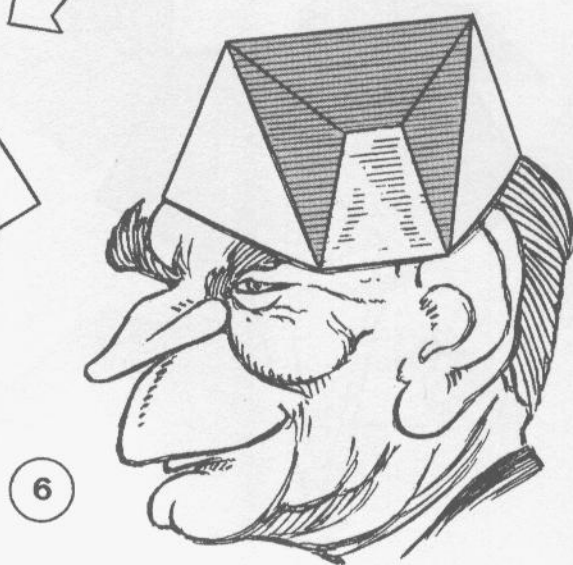
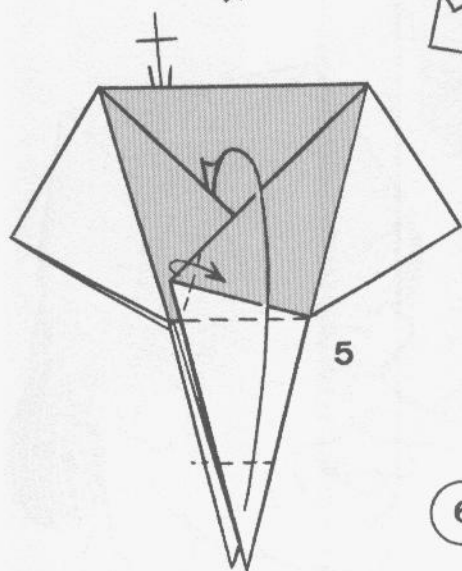
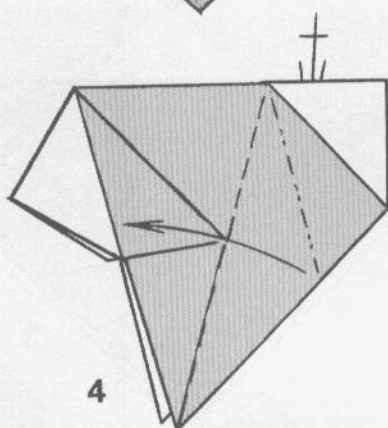
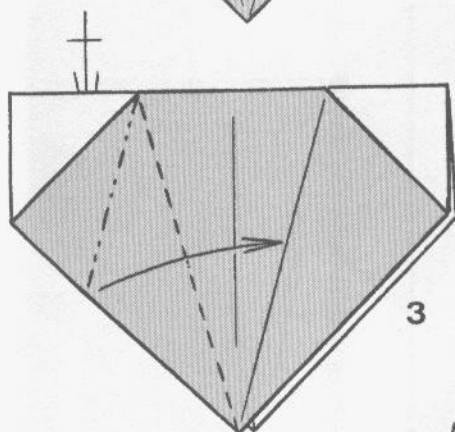
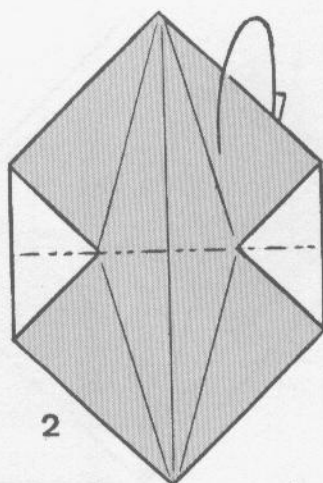
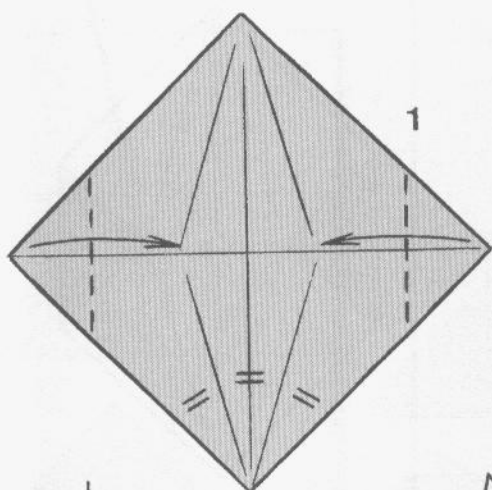

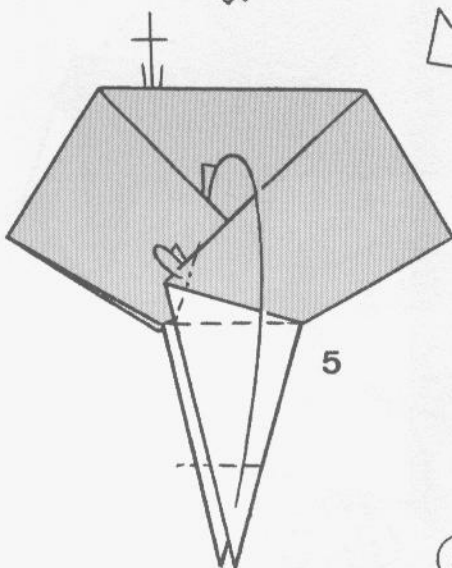
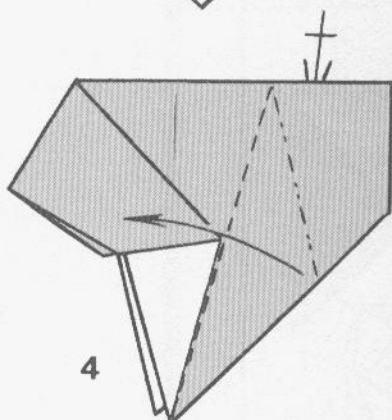
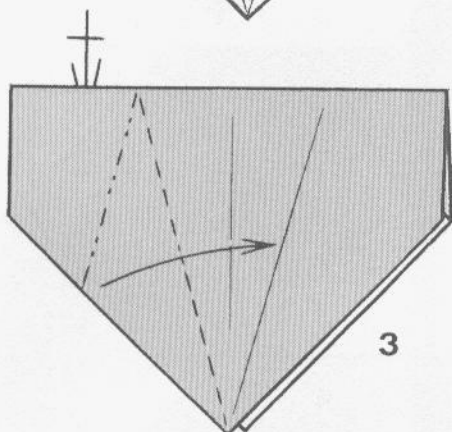
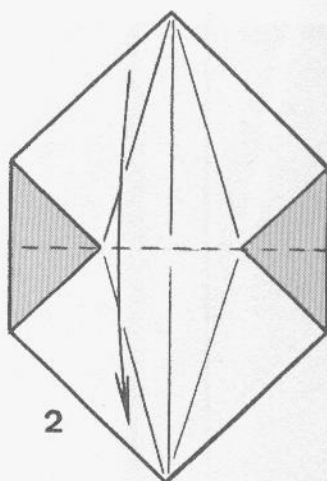
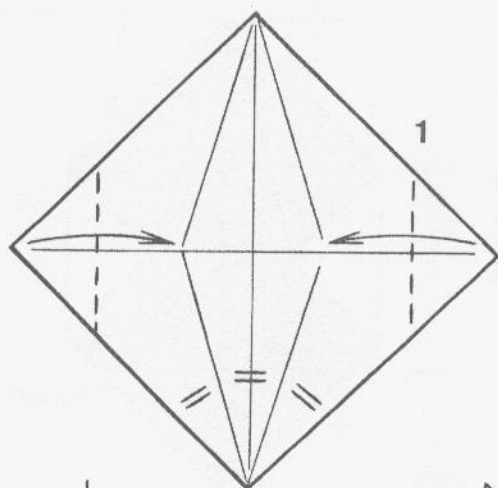

WINGED CUBE

Traditional

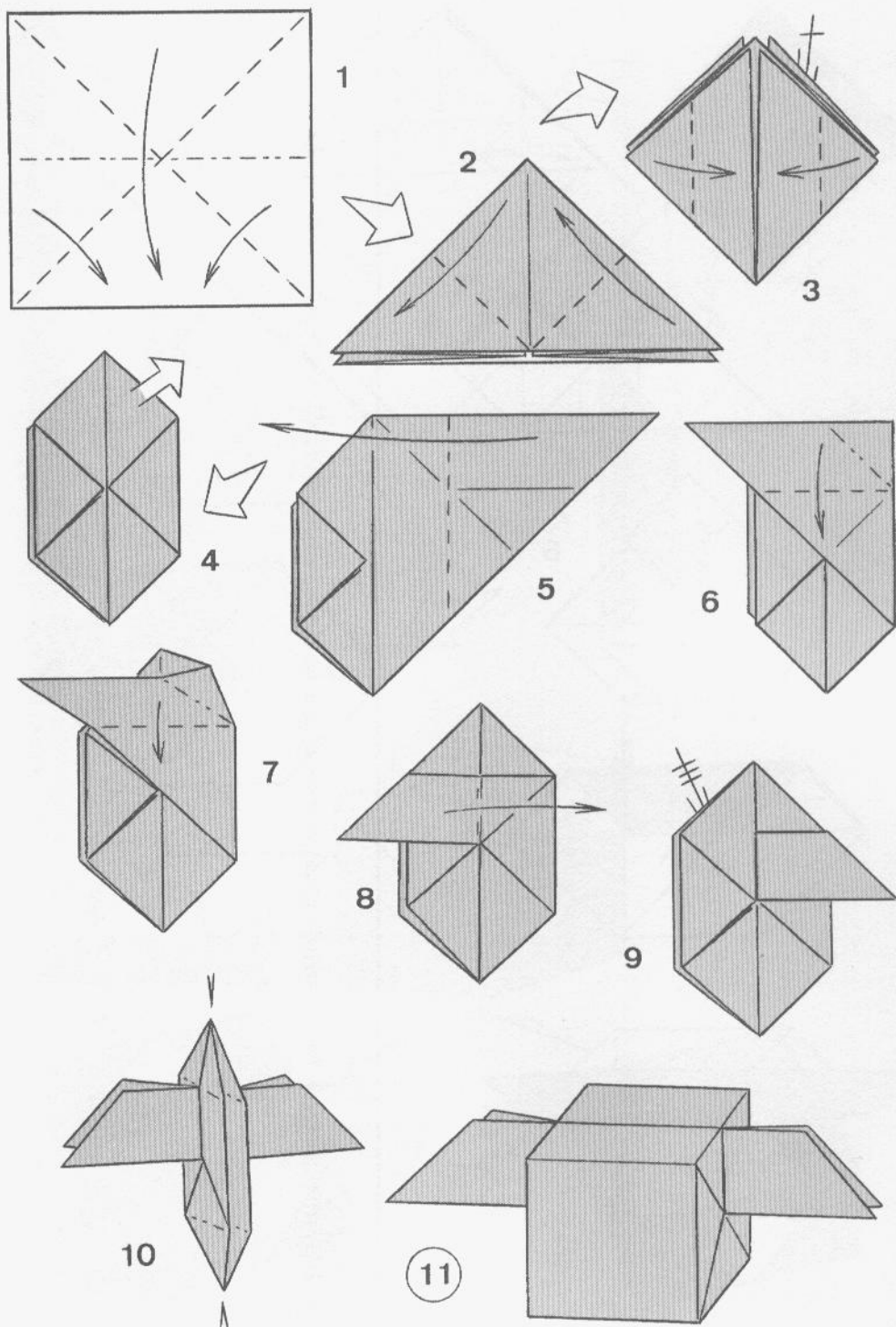

BOAT

by Victor Laschenko

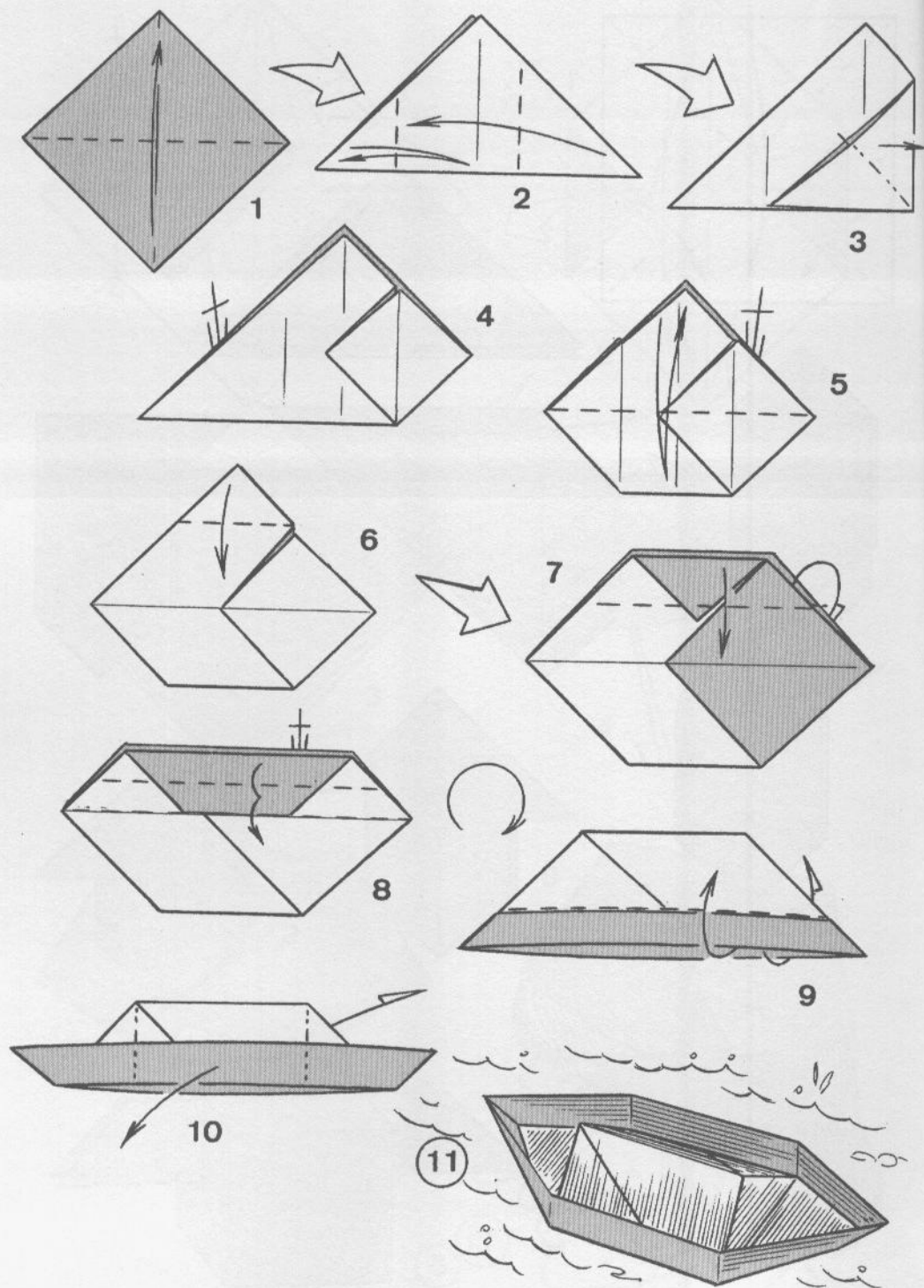

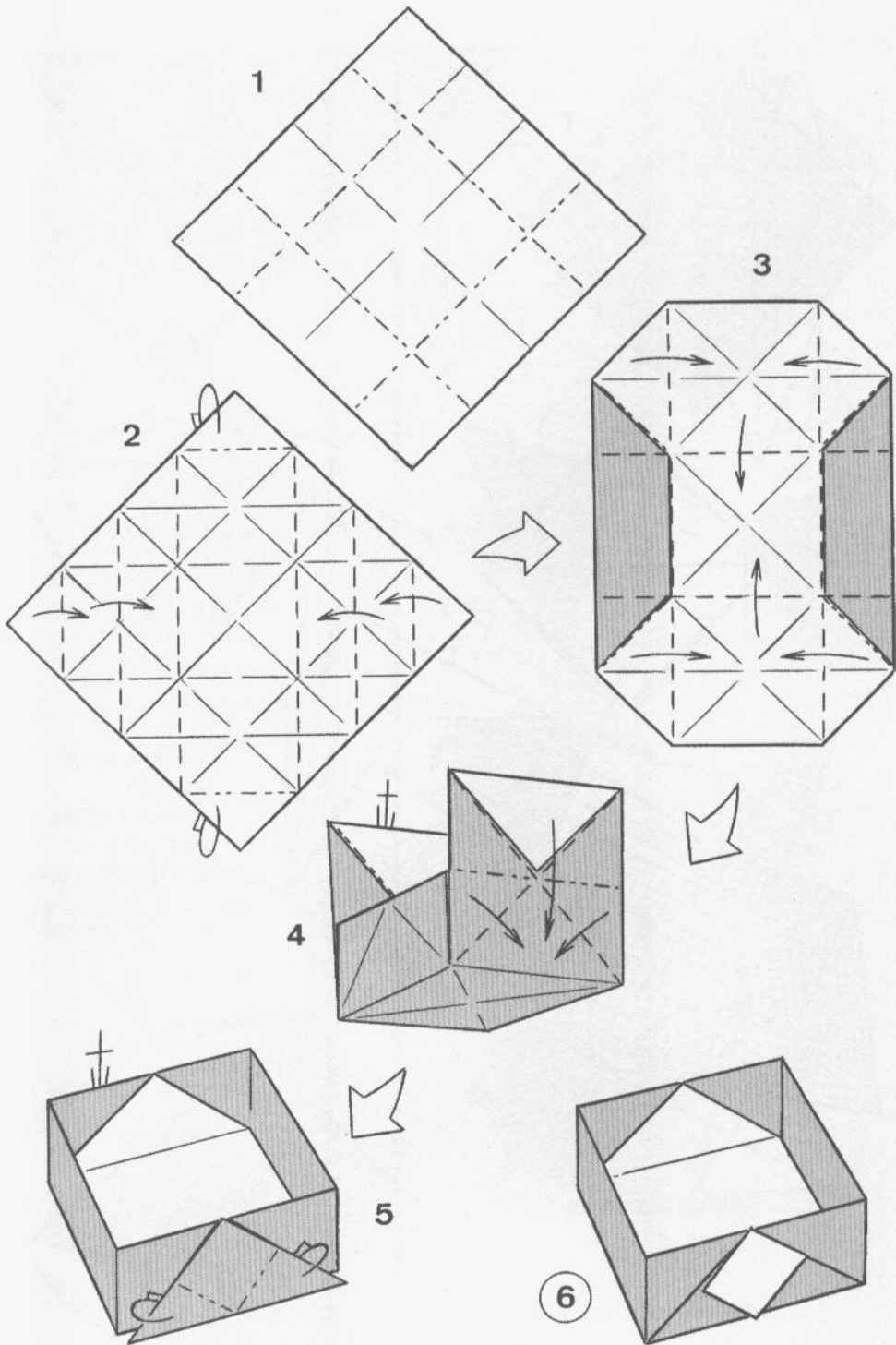

CENTERPIECE FOR TABLE

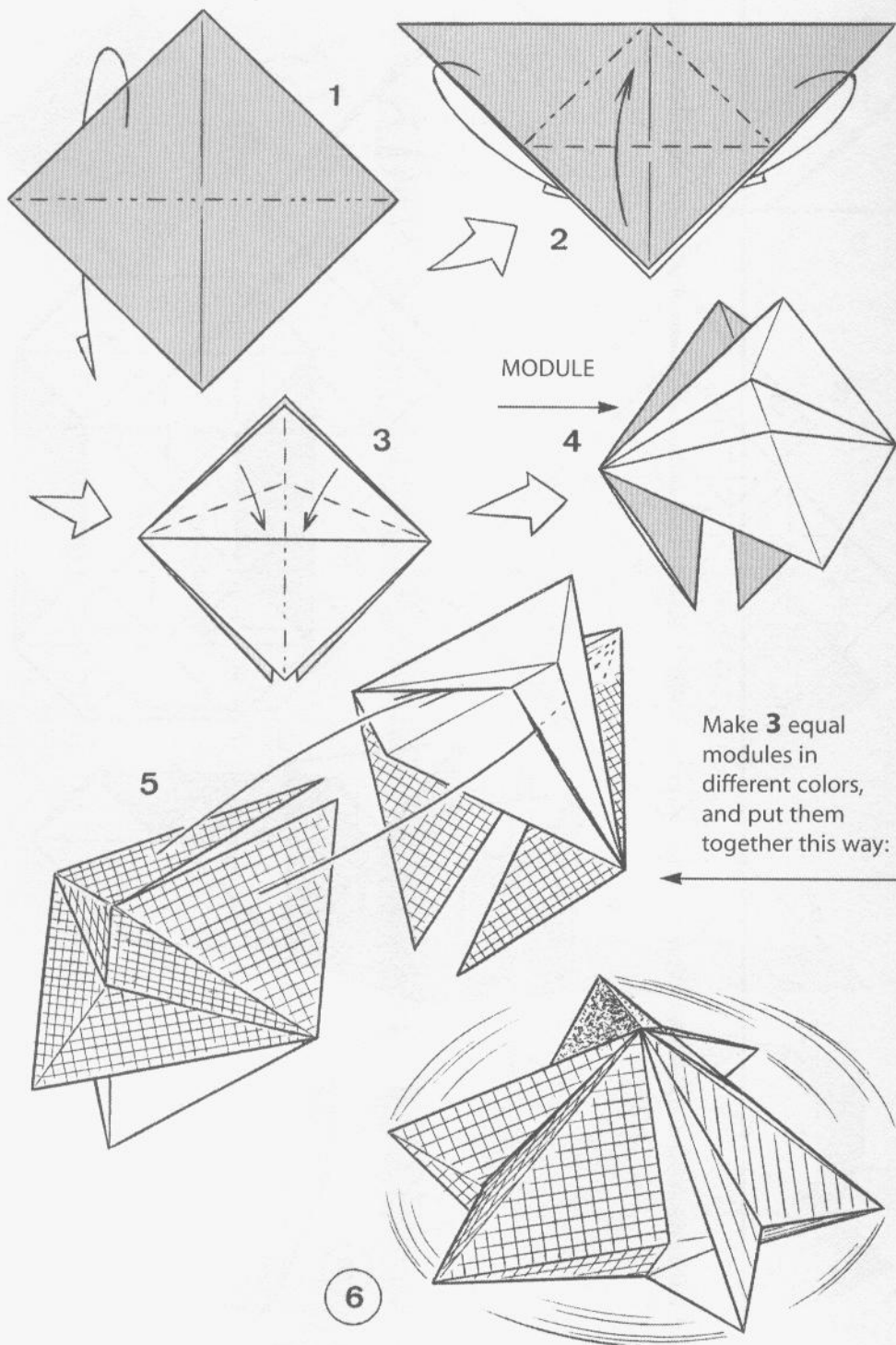

SPARROW

by Susana Arashiro

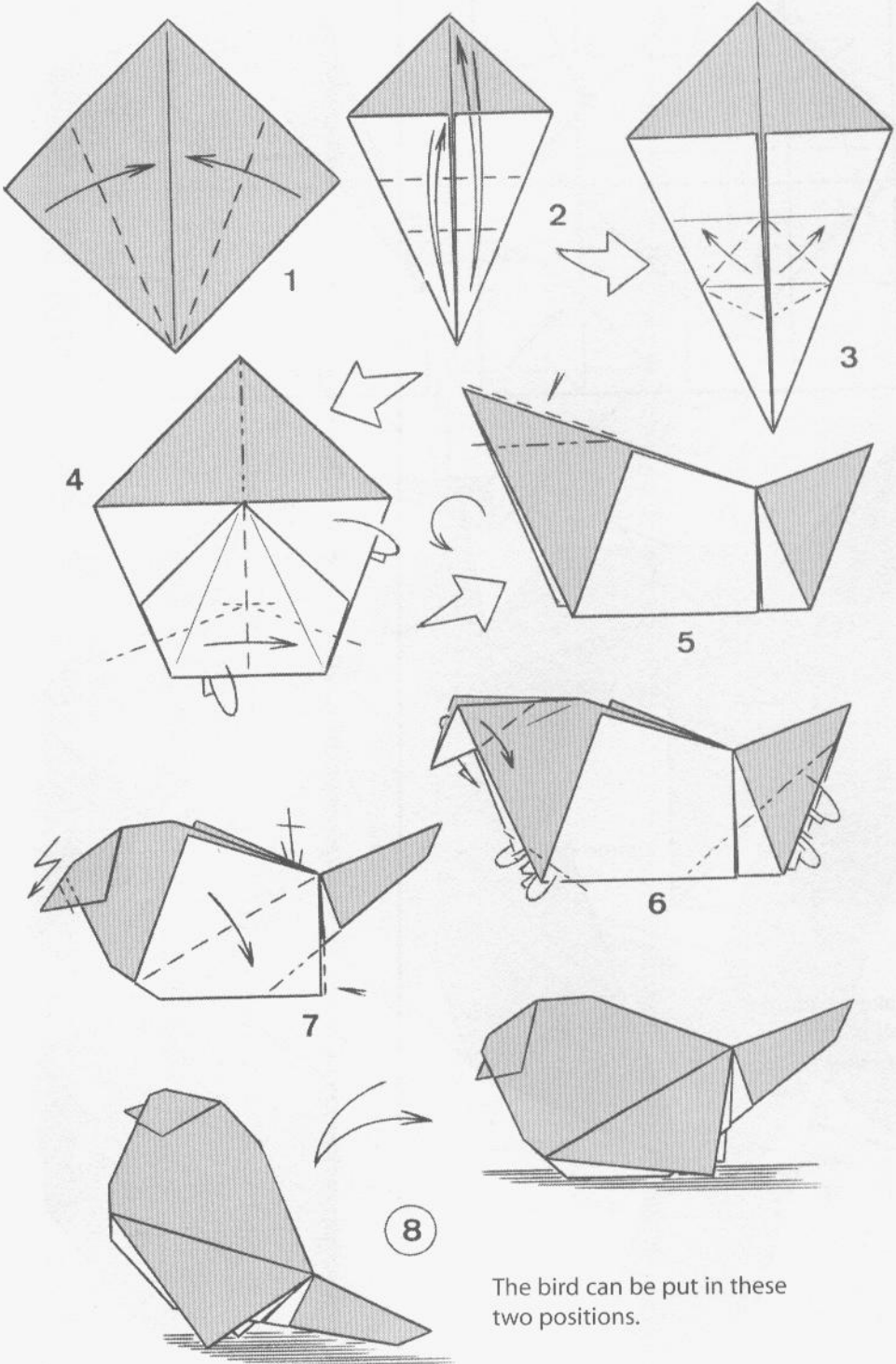

MODULAR CUBE 1

WOLFRAM

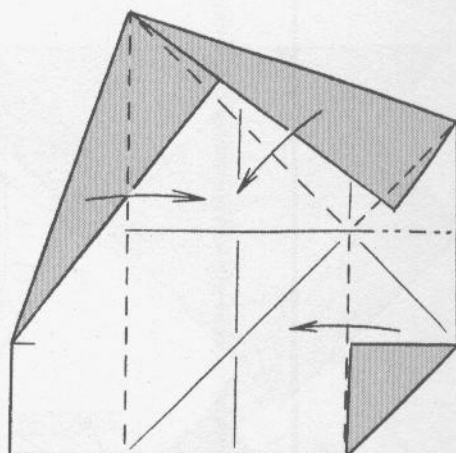
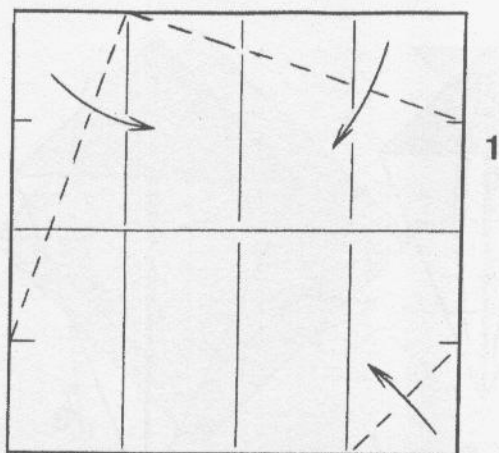

2

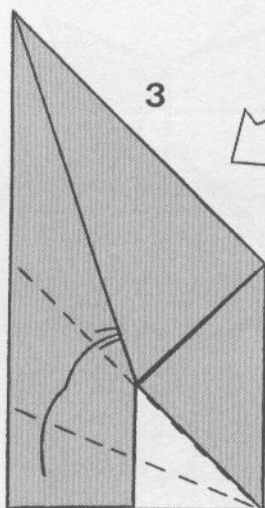

3

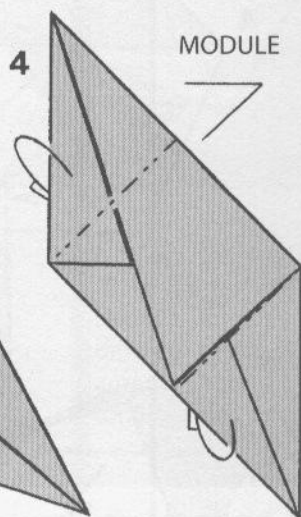

4

MODULE

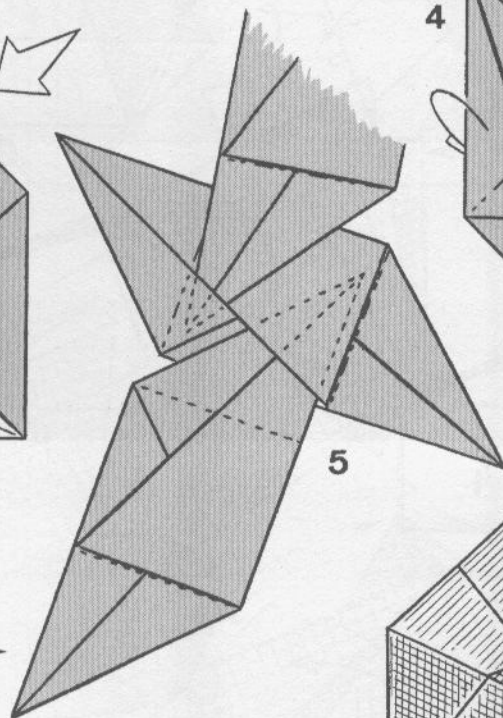

5

Make **6** modules and put them together this way:



6

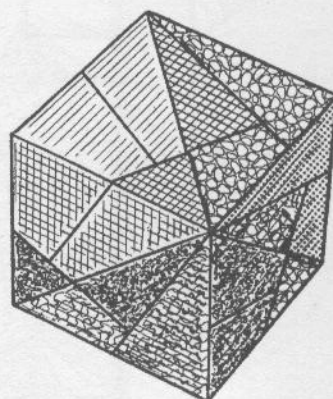

MODULAR CUBE 2

by Mari Kanegae

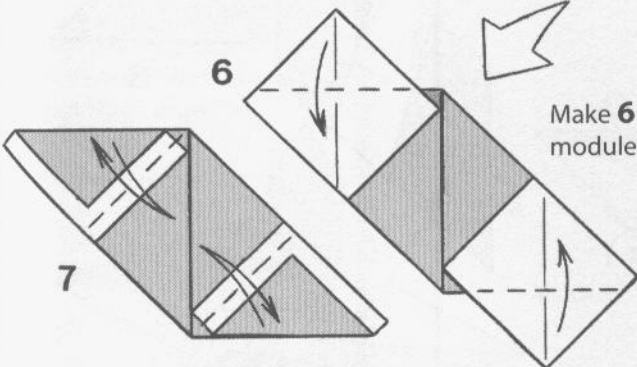
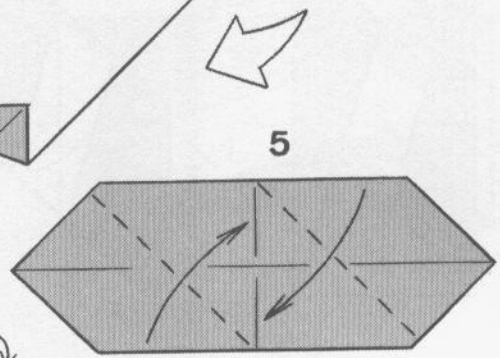
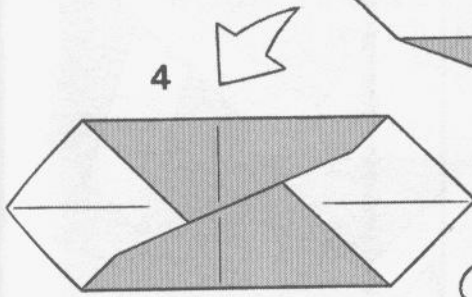
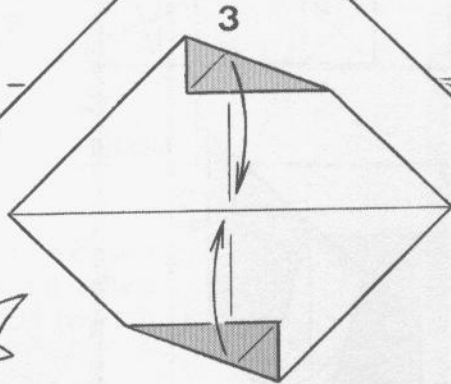
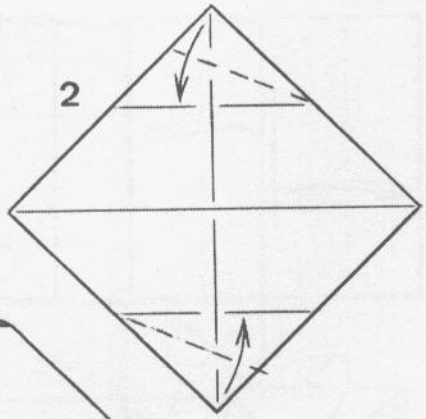
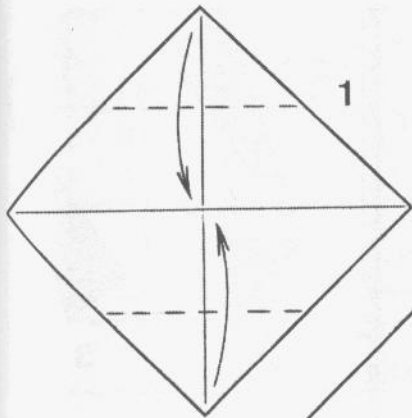

Make 6 equal modules ...

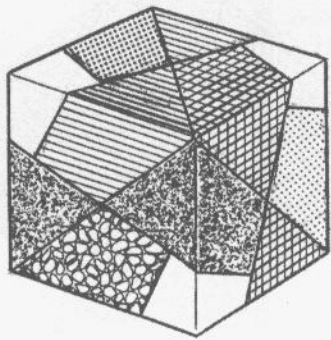

... and put them together this way:

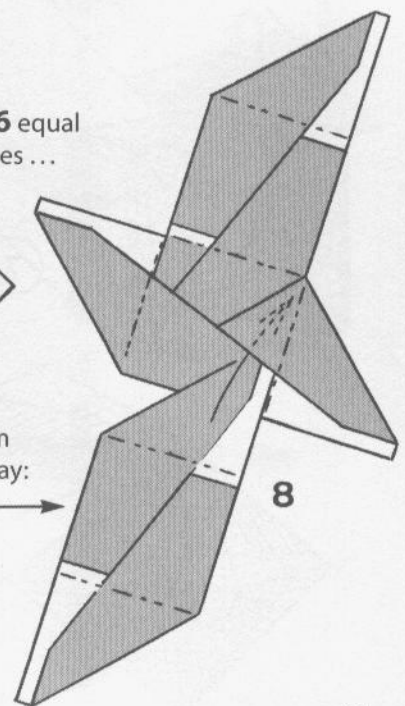

MODULAR CUBE 3

by Vicente Palacios

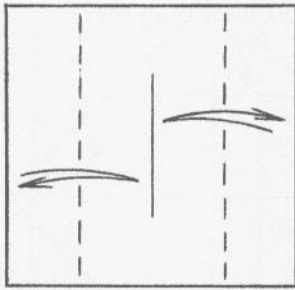

1

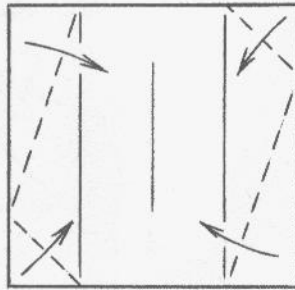

2

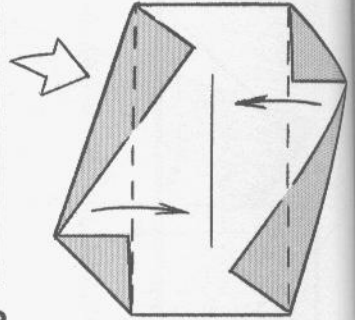

3

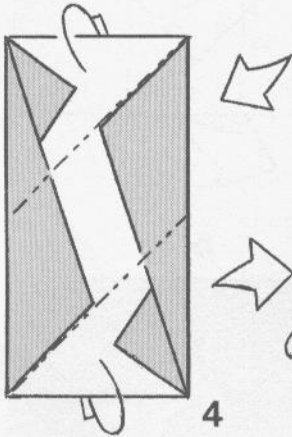

4

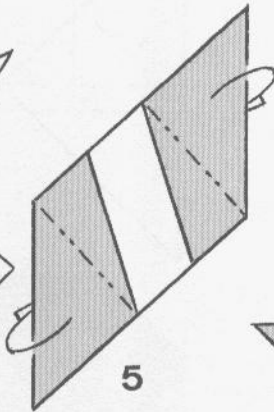

5

MODULE

Make 6 modules and put them together this way:

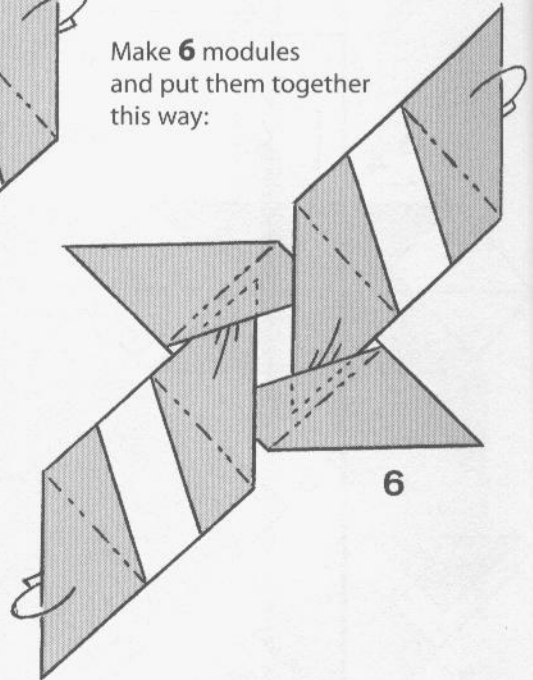

6

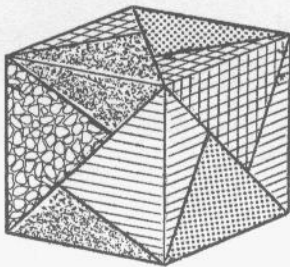

7

WITH 12 MODULES

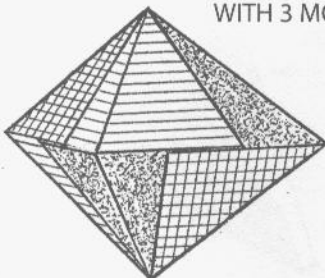

WITH 3 MODULES

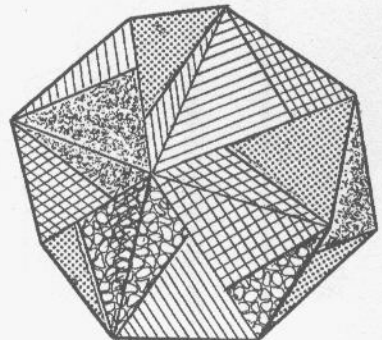

MODULAR CUBE 4

by Vicente Palacios

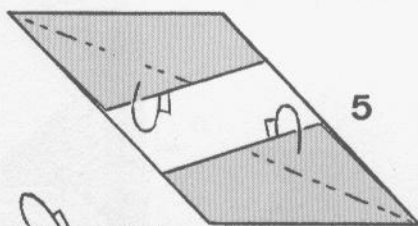
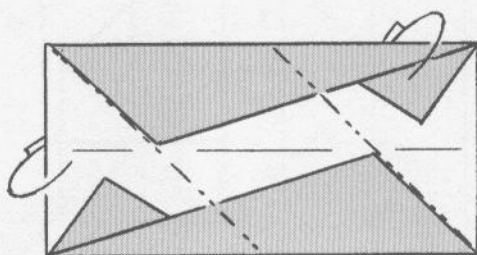
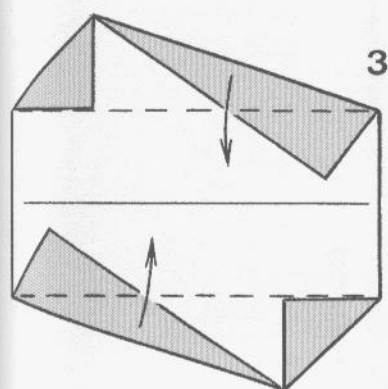
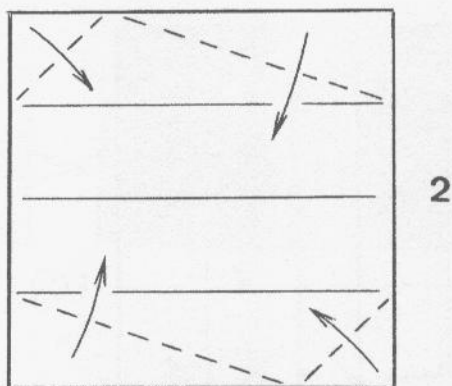
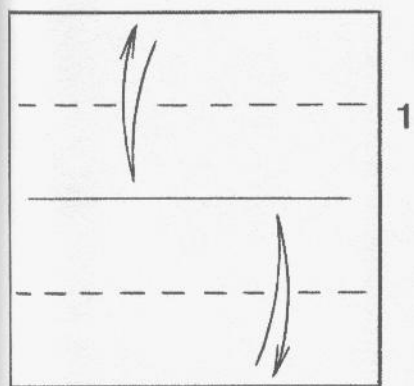

Make **6** modules of different colors and put them together this way:

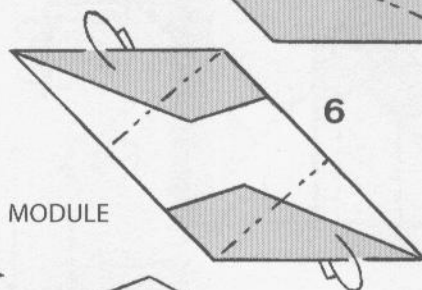
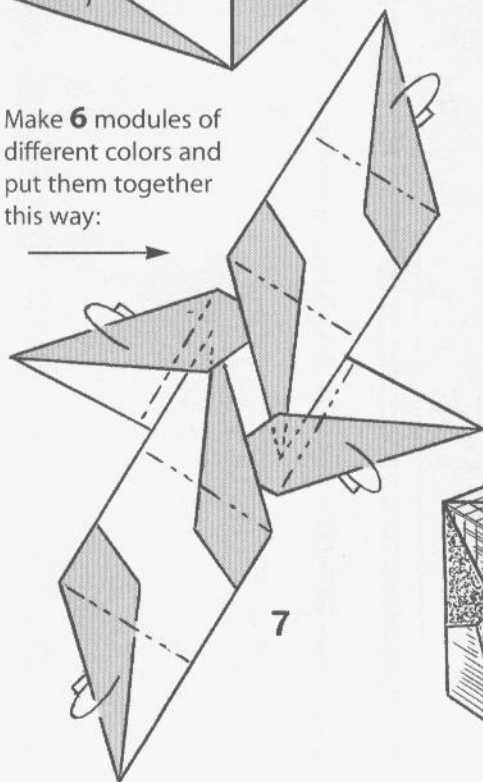
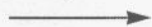

MODULE

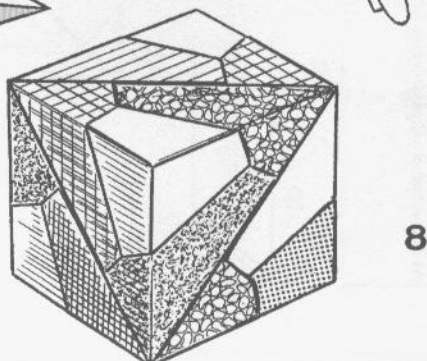

LITTLE BIRD BOOKMARK

by Vicente Palacios

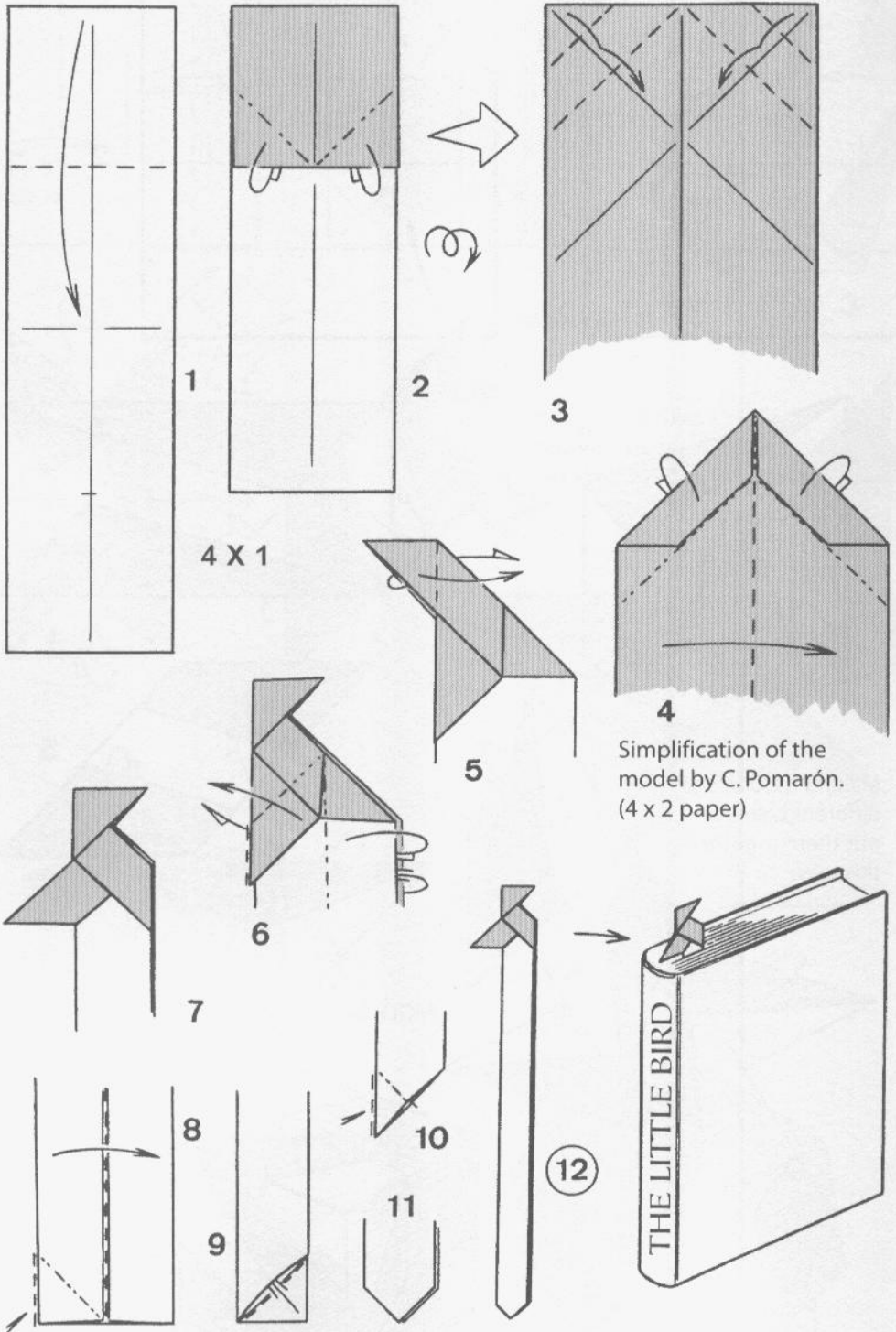

CELTIC HELMET

Traditional

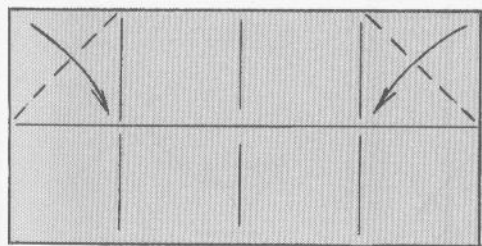

1

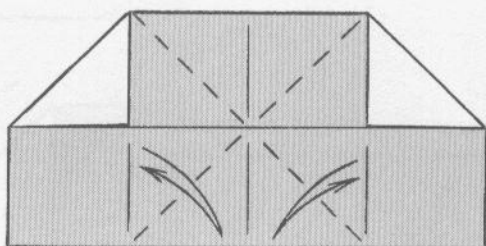

2

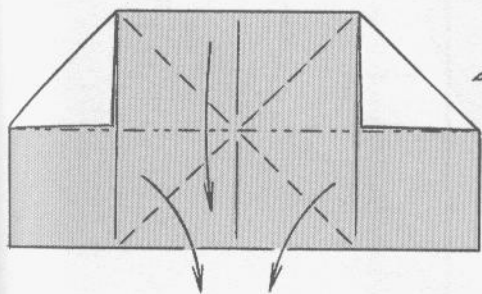

3

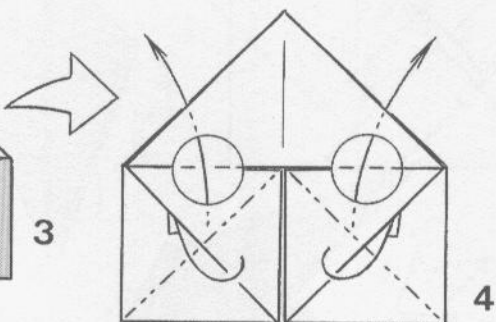

4

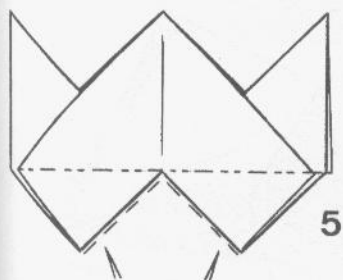

5

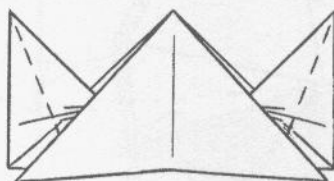

6



7

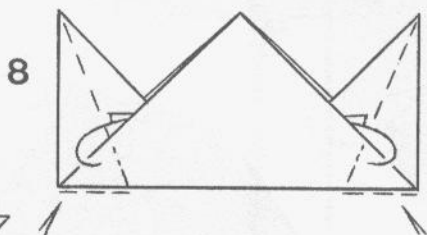

8



9

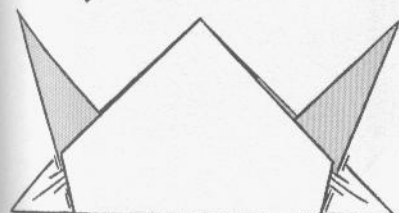

10



31

AIRPLANE

by Francisco Javier Caboblanco

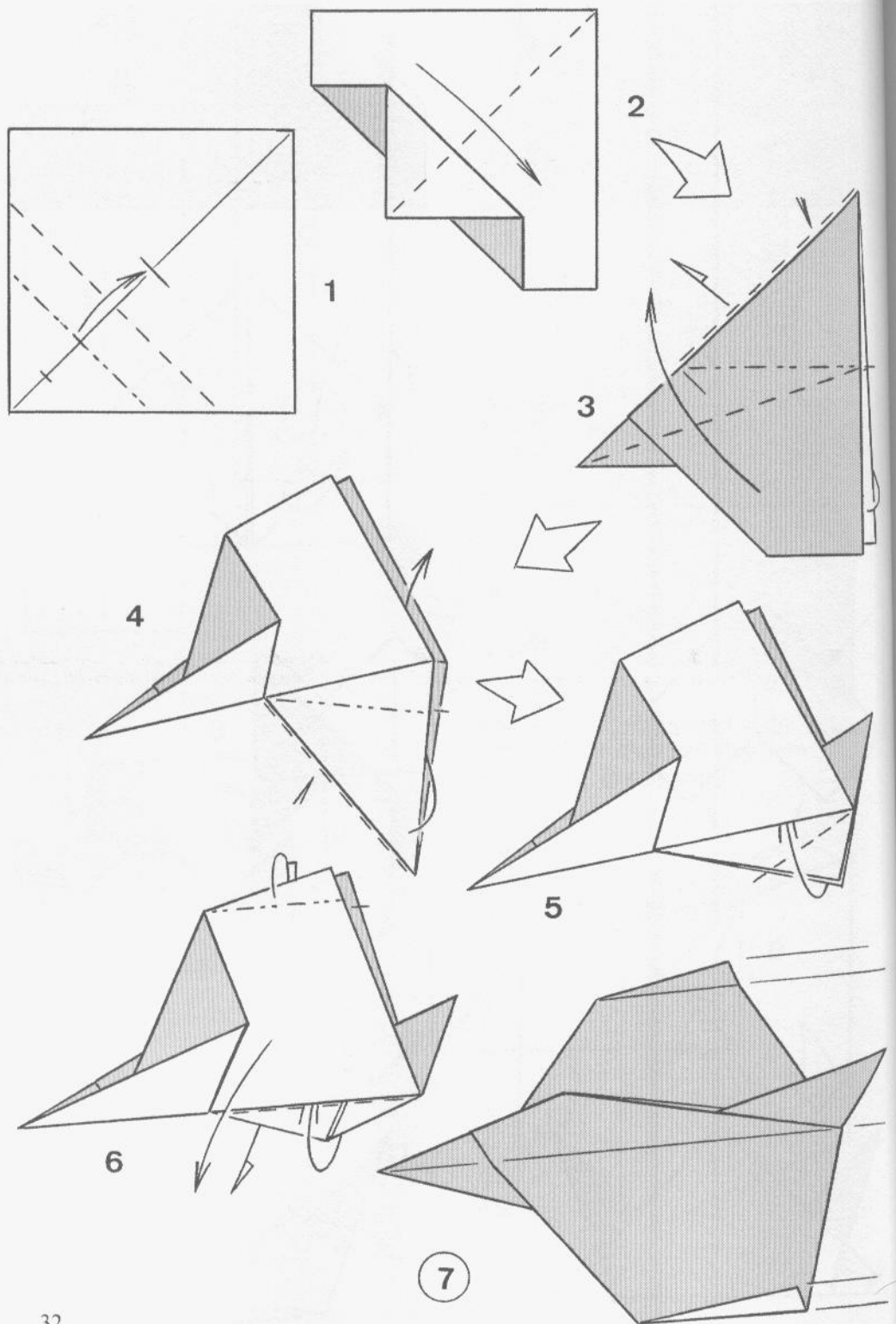

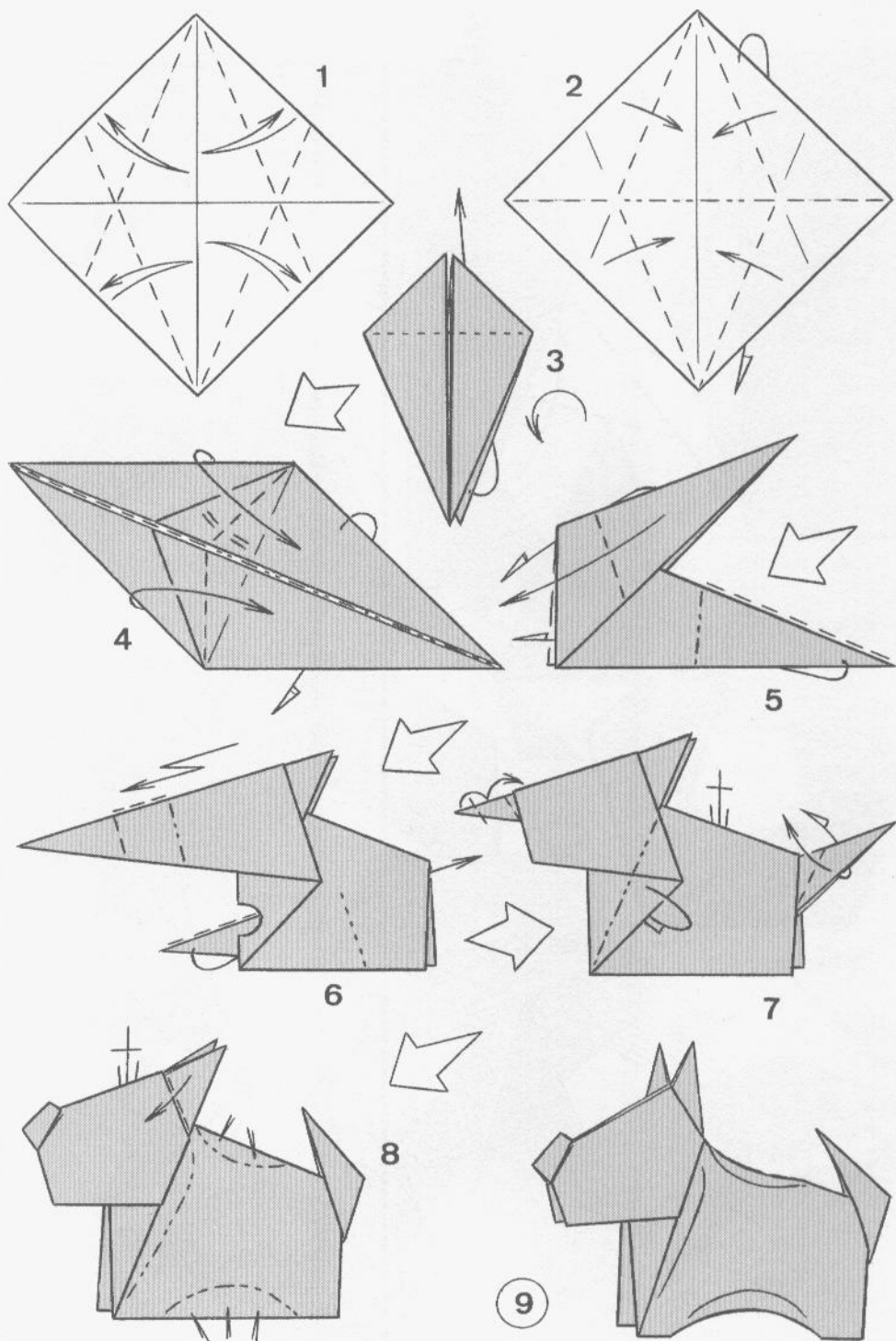

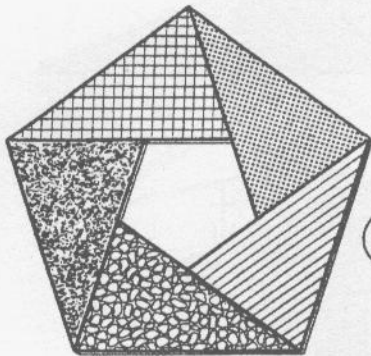
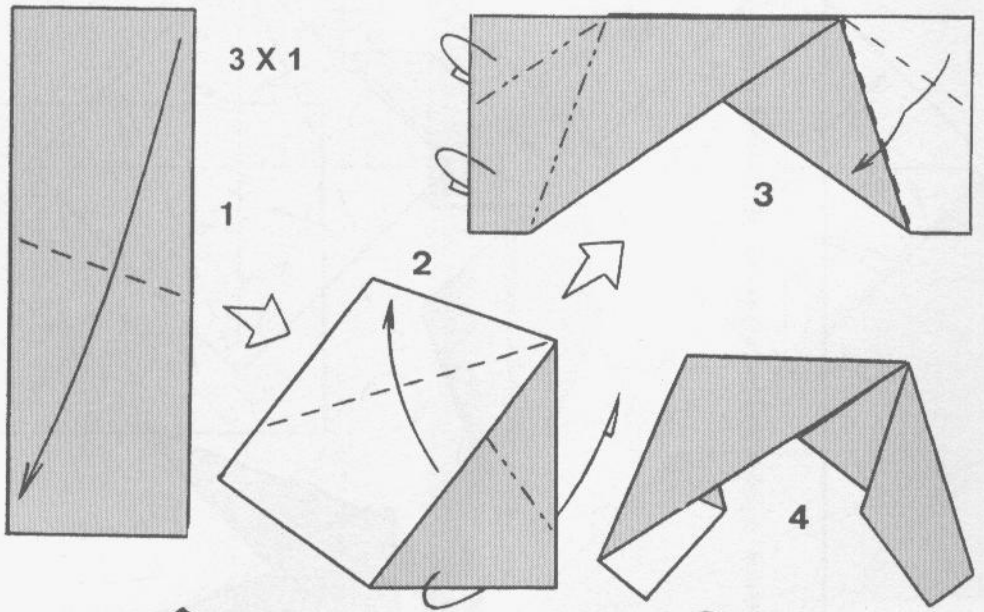

6A

With 5 modules

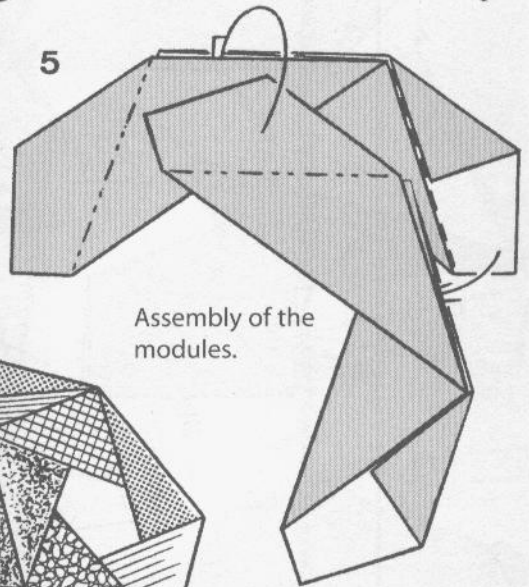

Assembly of the modules.

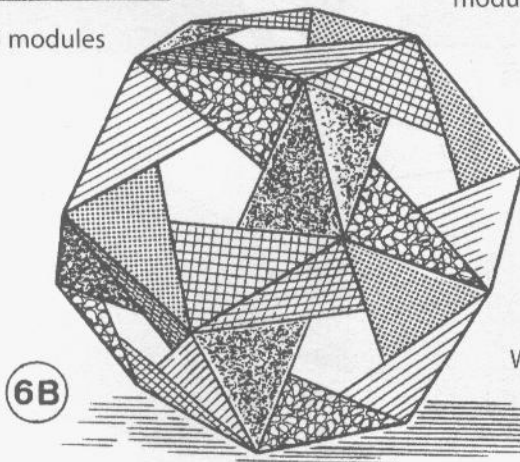

6B

With 30 modules

"TATO" WRAPPER

Traditional in Japan

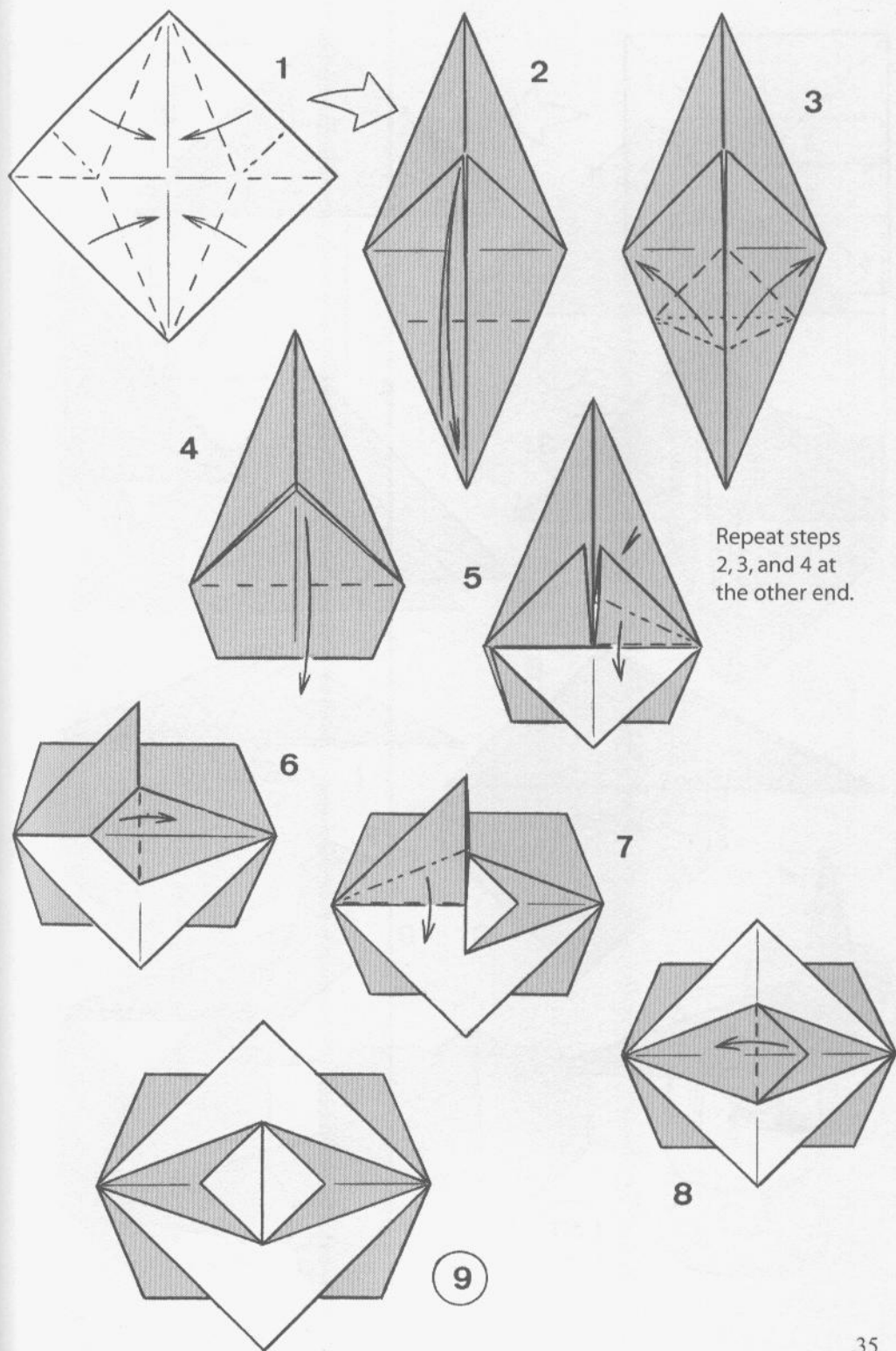

DOVE

by Dr. V. Solórzano

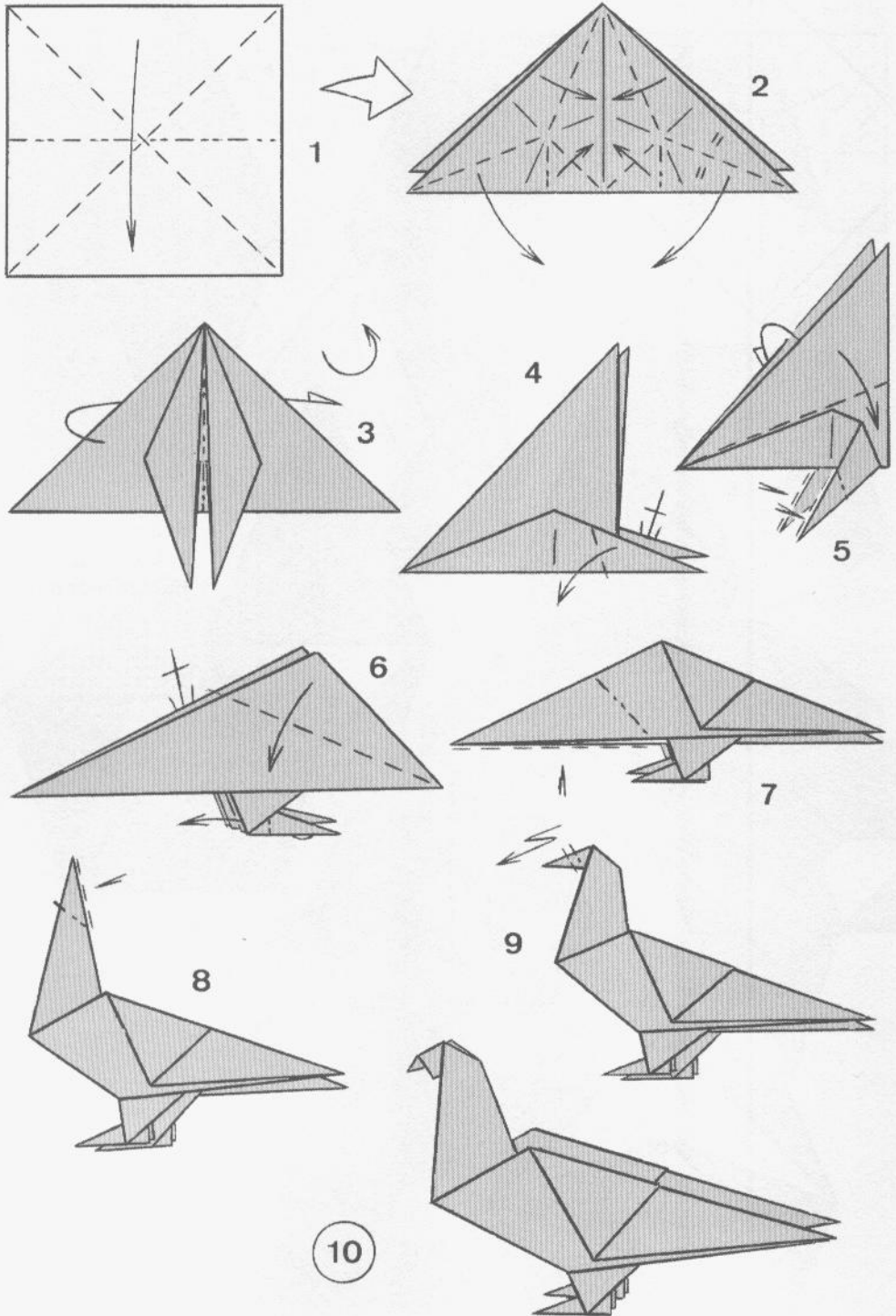

HEART FOR A DRINKING GLASS

by Sandra Afonkina

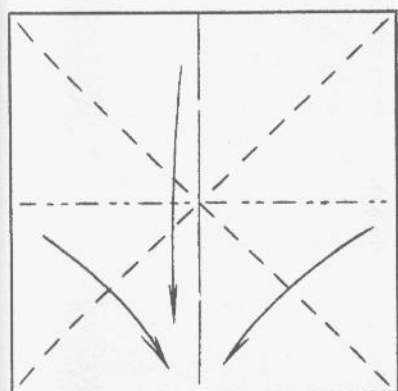

1

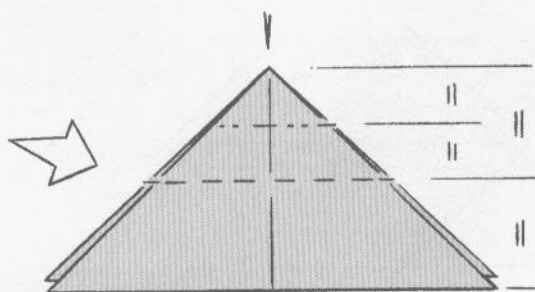

2

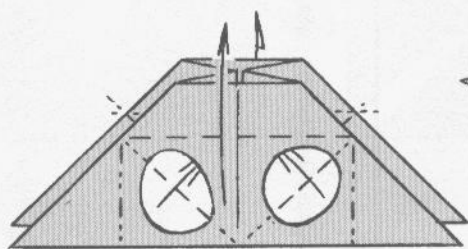

3

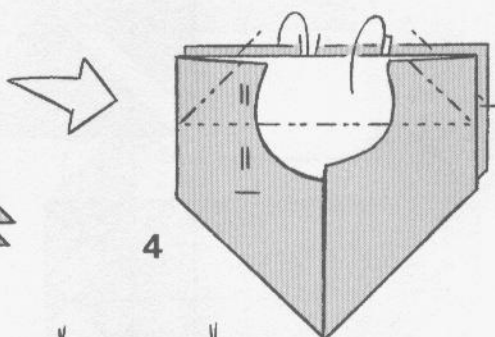

4

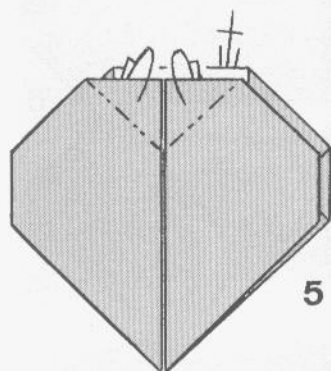

5

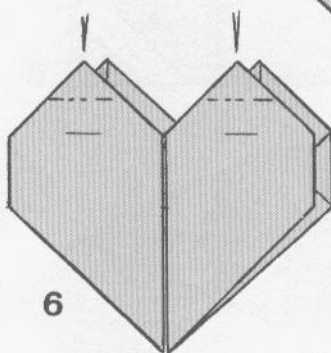

6

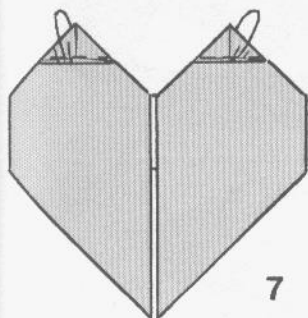

7

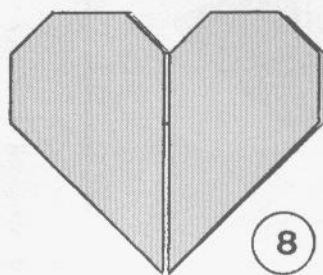

8

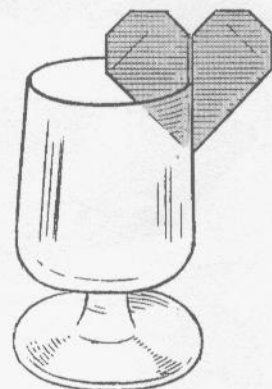

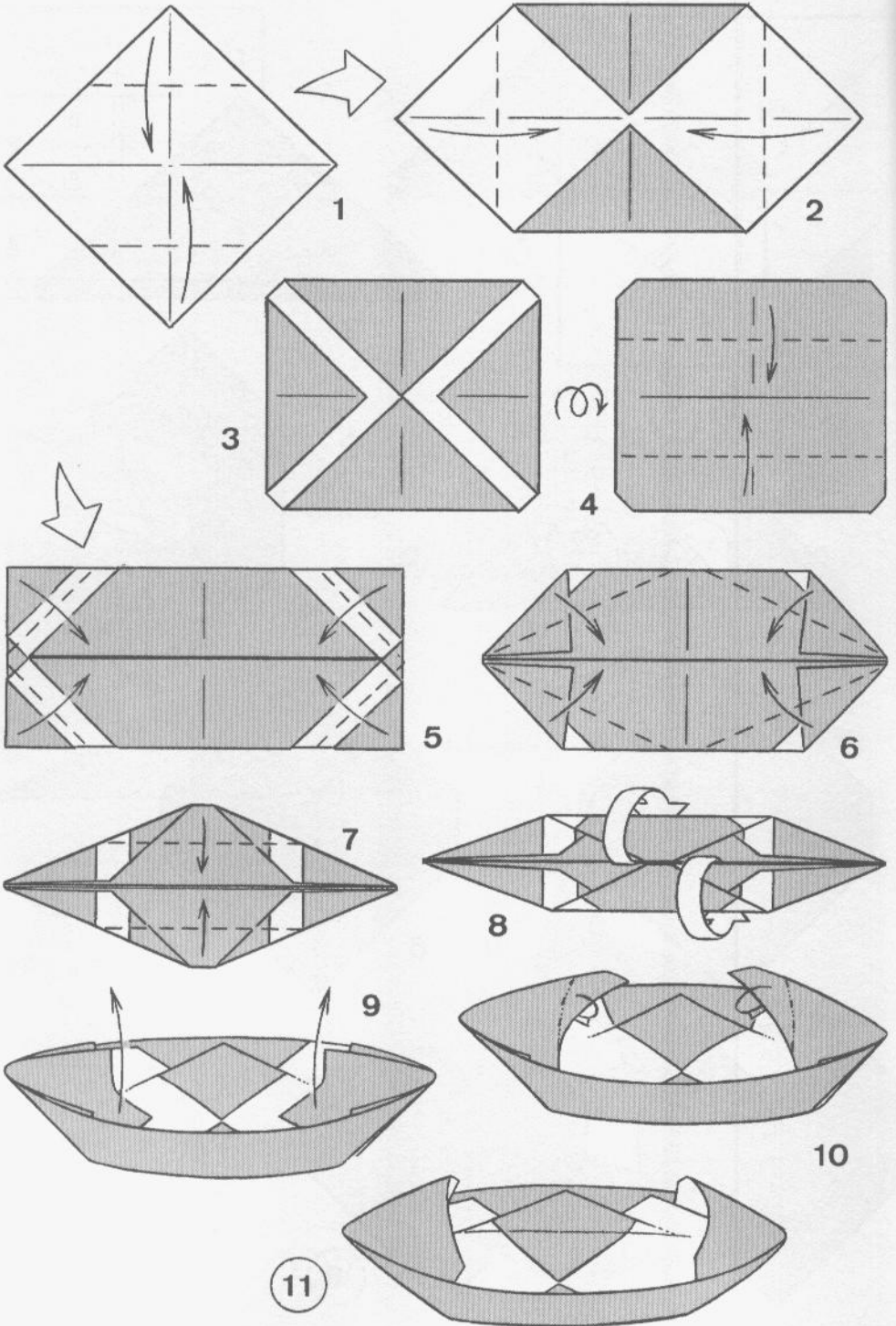

BIRD'S PERCH

by Luis Fernández

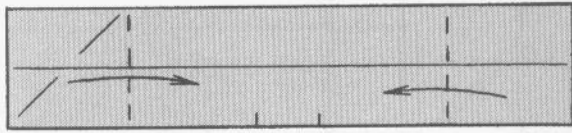

4.5 x 1

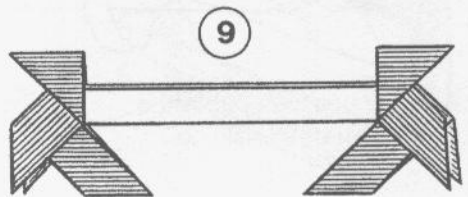
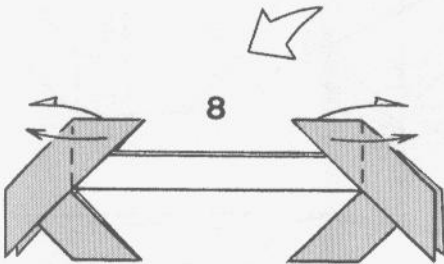
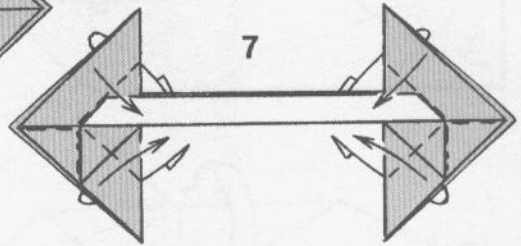
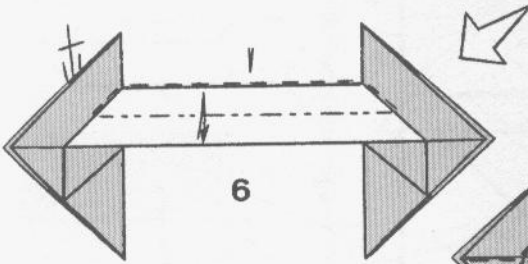
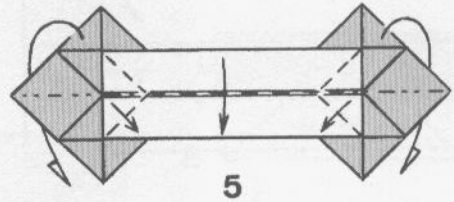
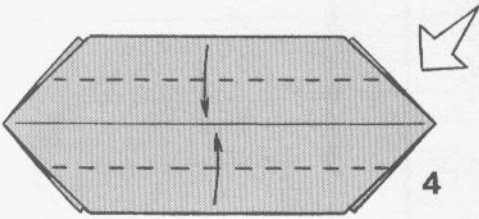
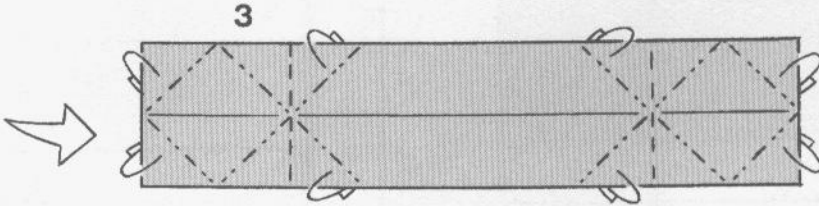
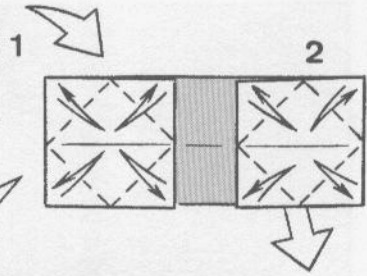

ROWBOAT

Variant by Dr. Philip Shen

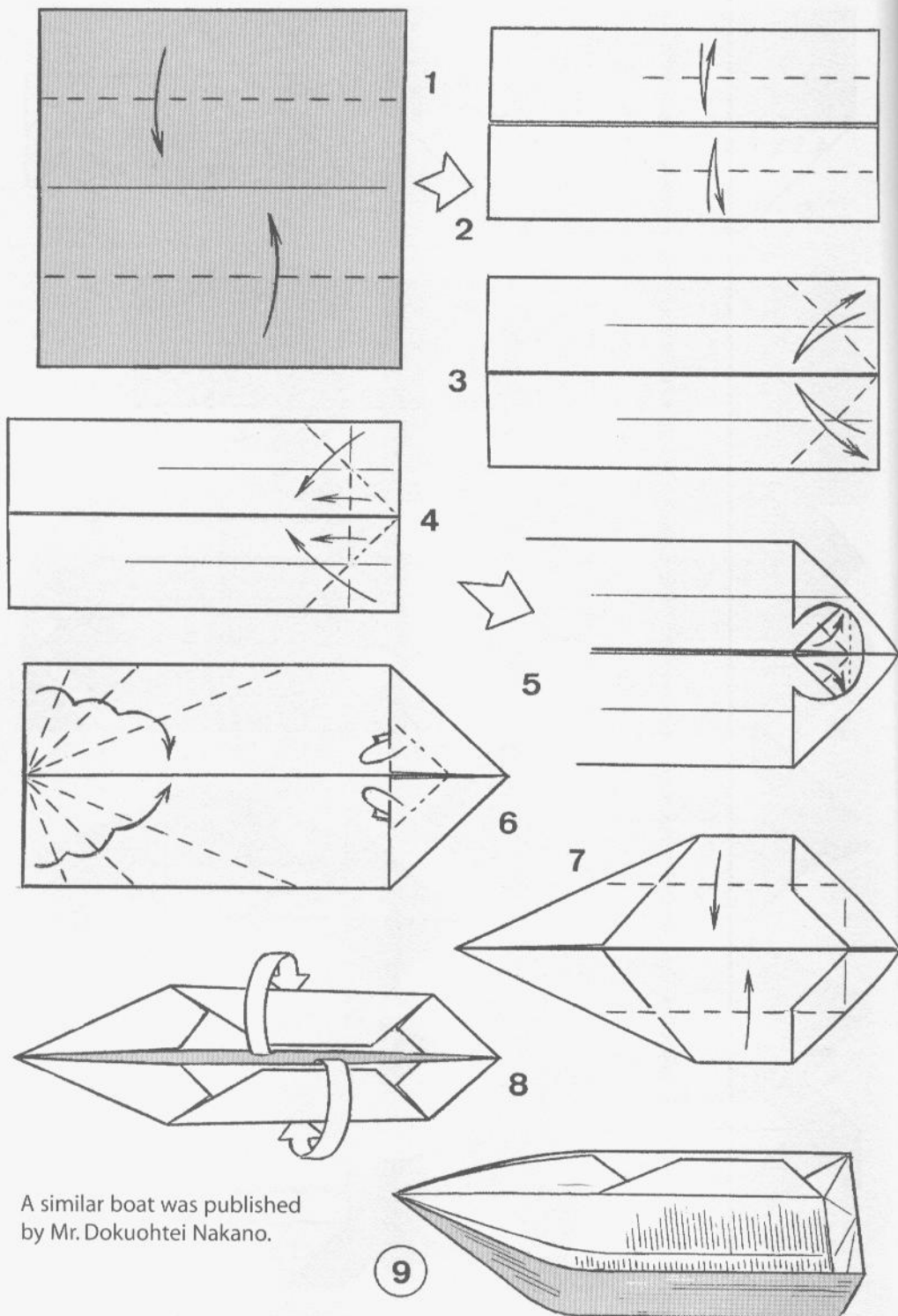

A similar boat was published by Mr. Dokuohtei Nakano.

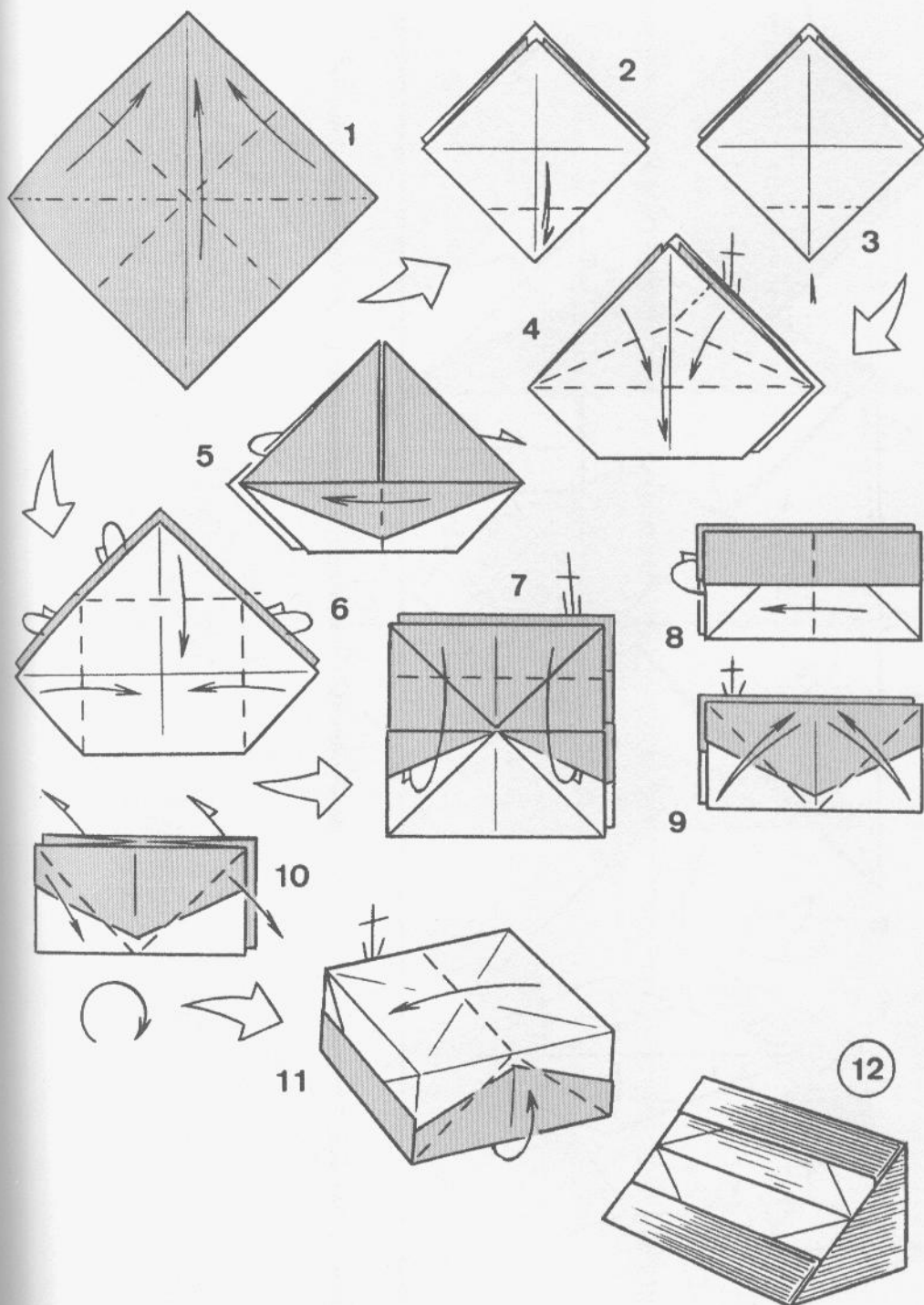

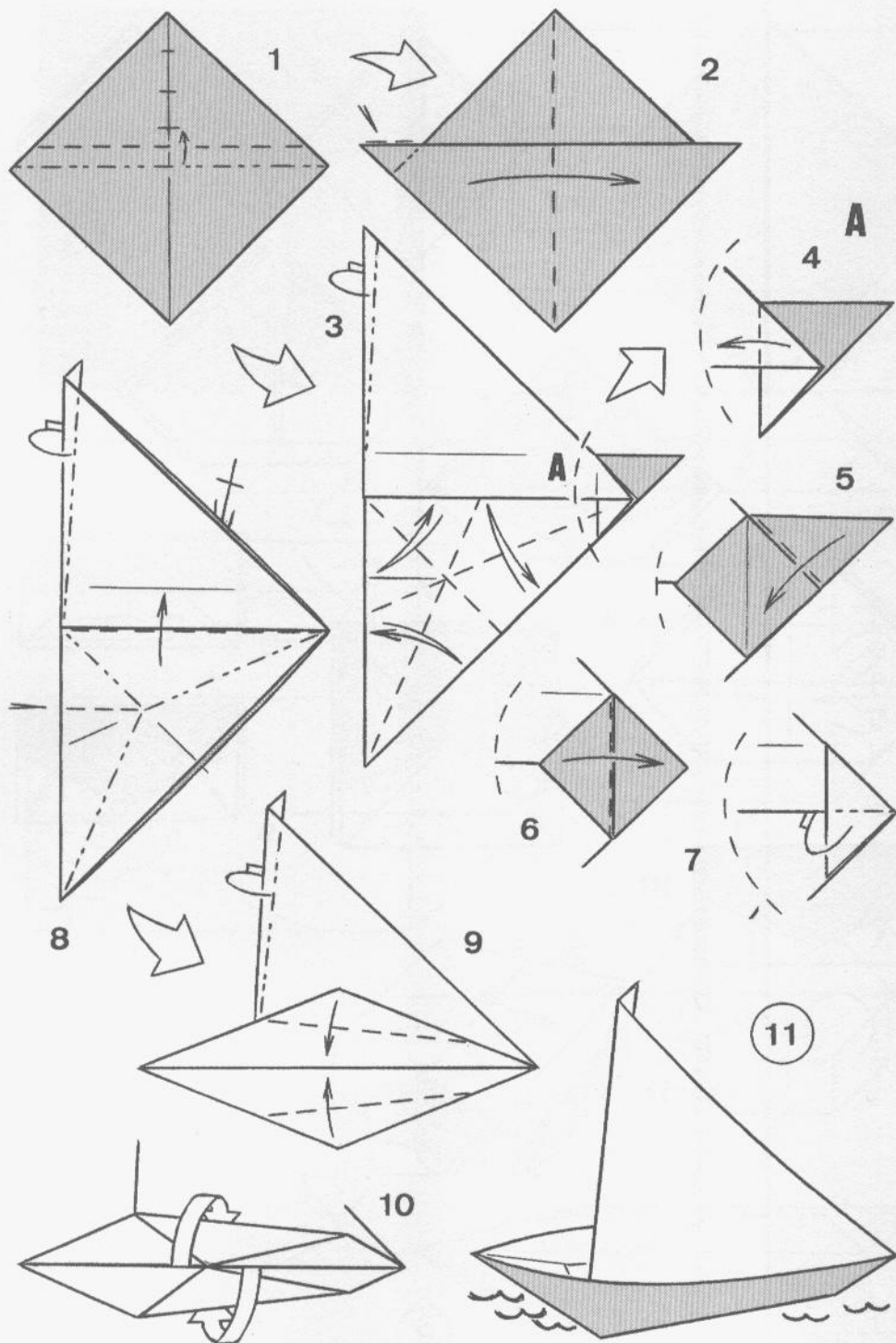

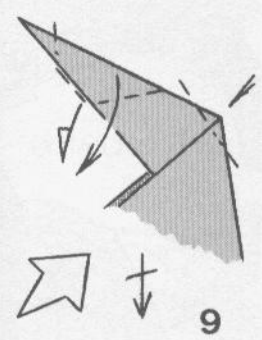
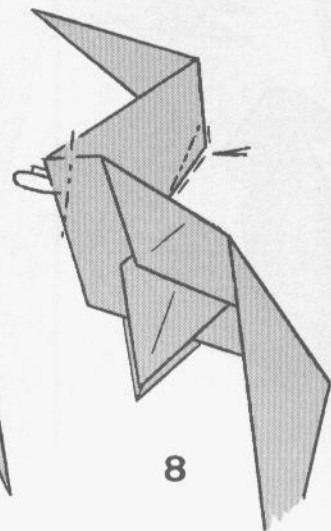
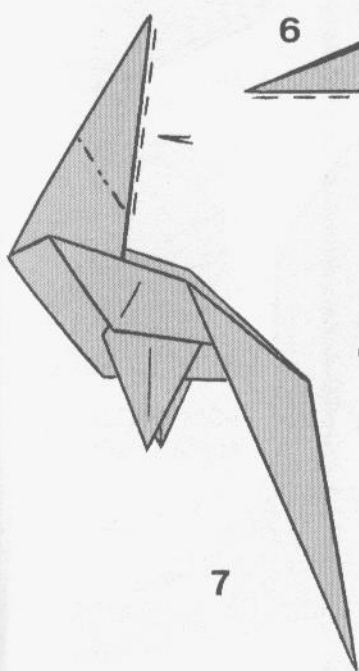
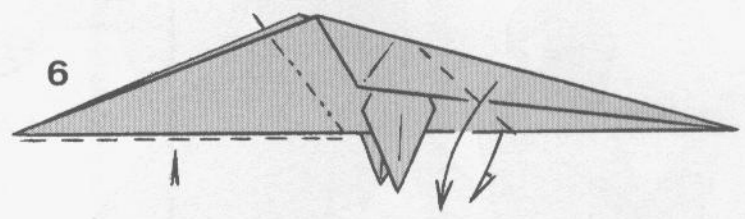
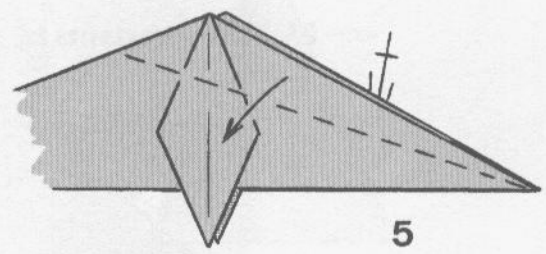
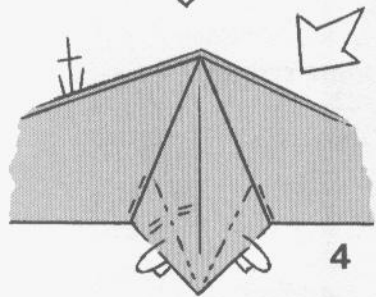
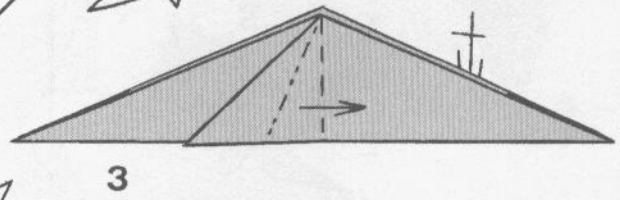
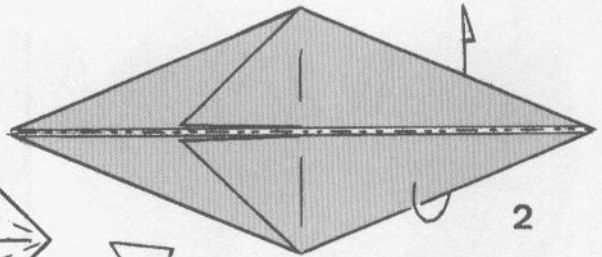
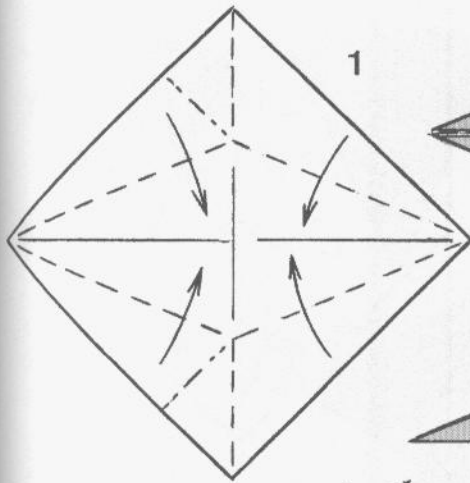

FOLDING OF THE FEET

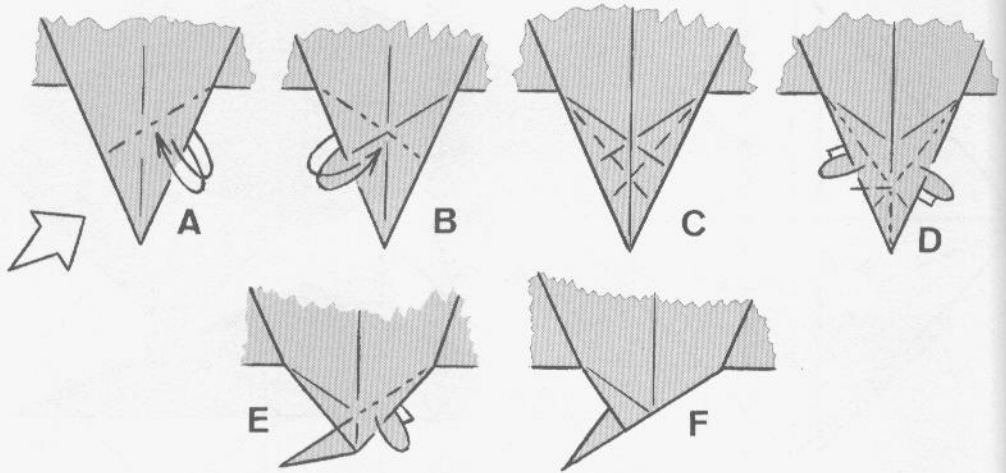

PARROT - Variants by the same creator

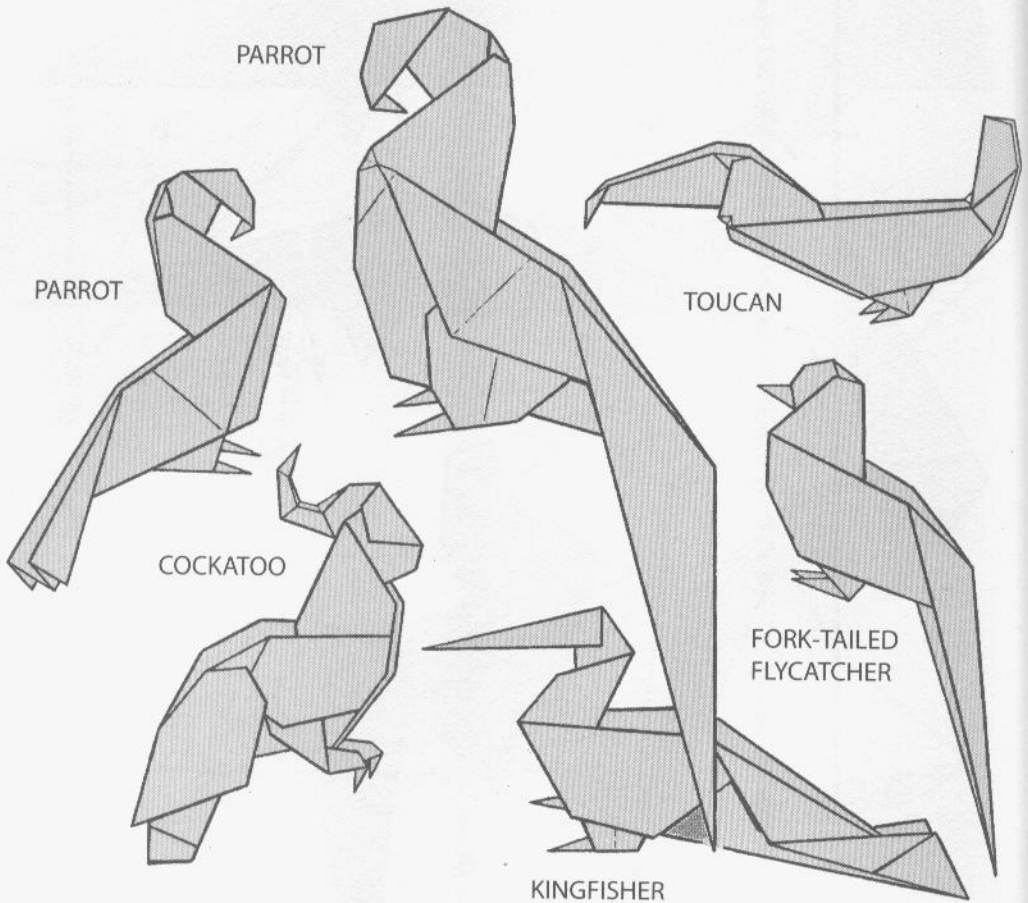

BIRD IN FLIGHT

Traditional

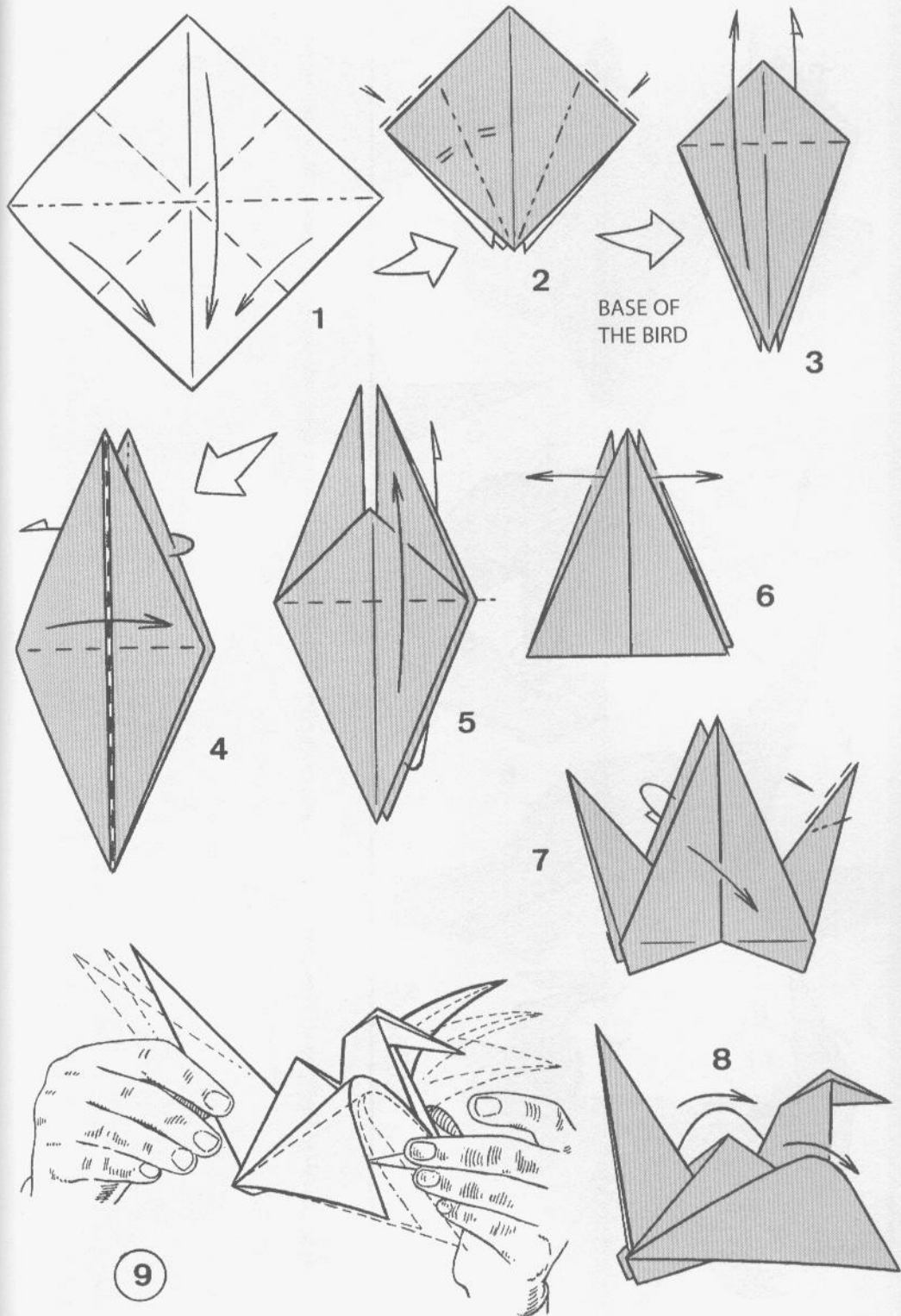

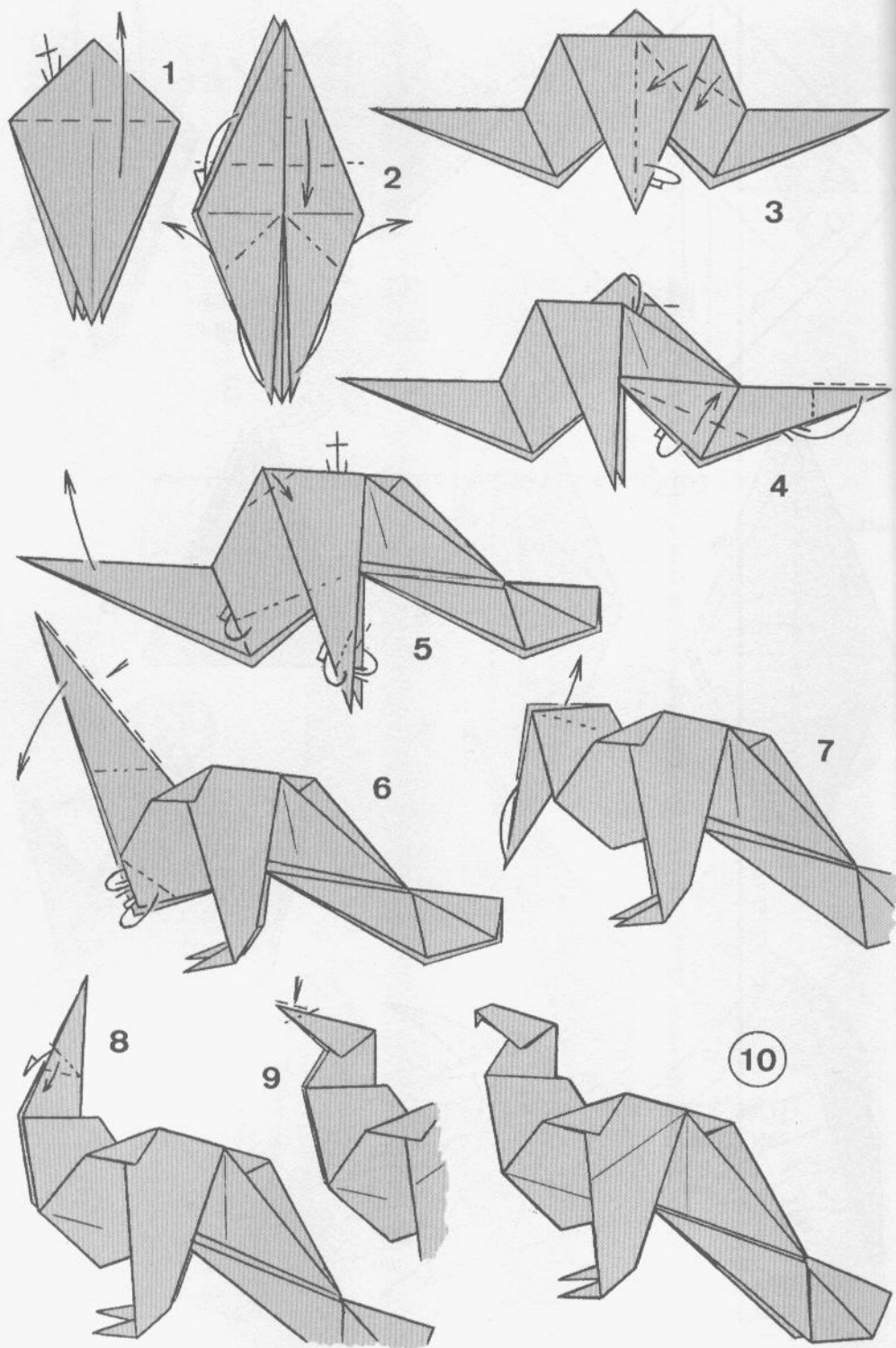

BUZZARD

by Dr. V. Solórzano

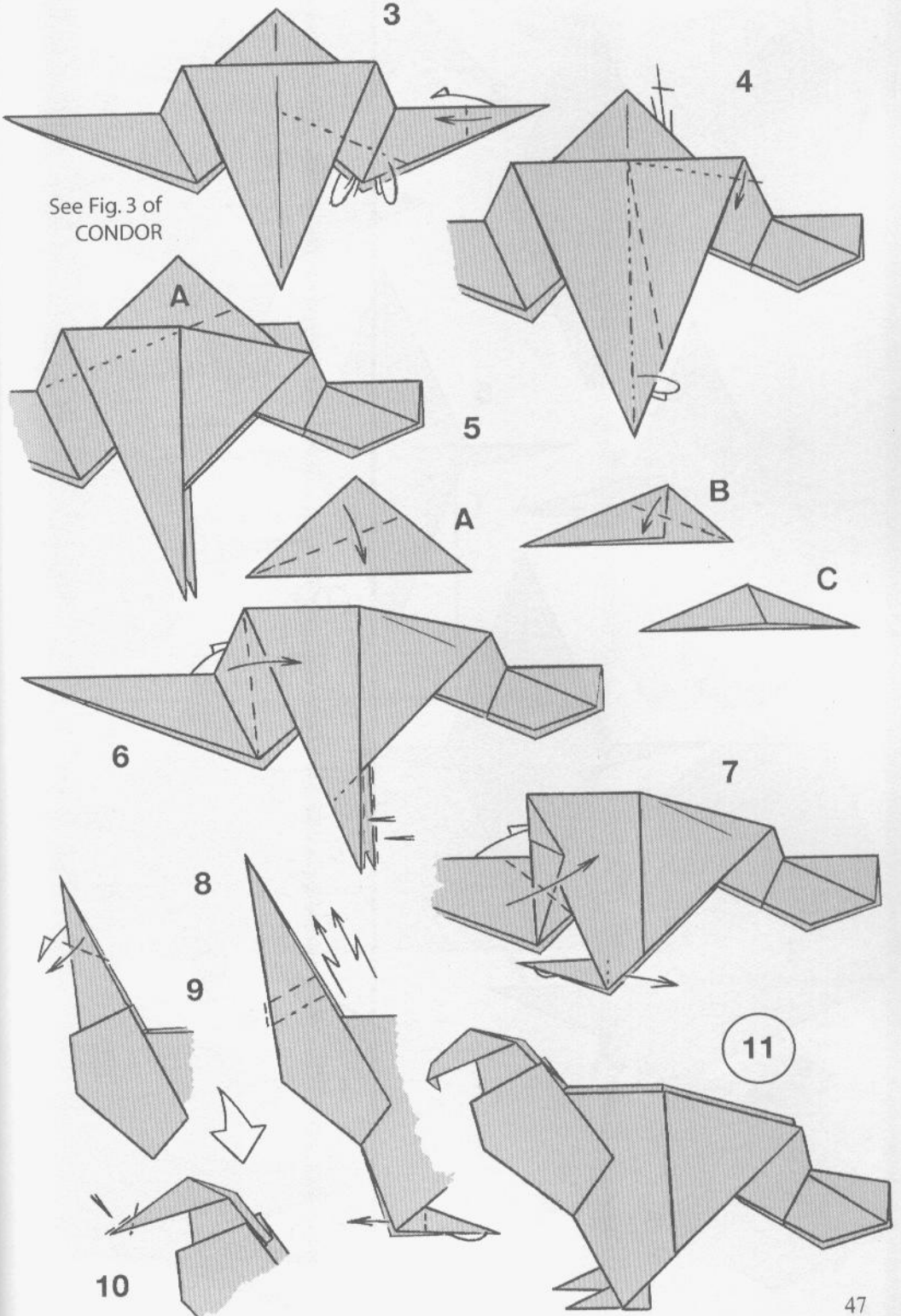

BIRD

Variant of a dove by Joshizawa

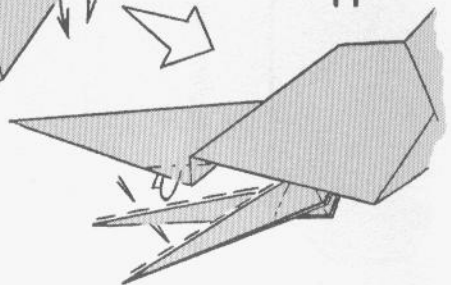
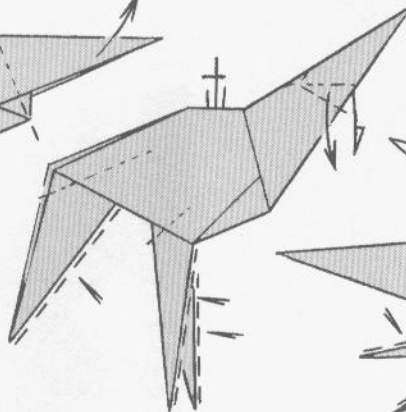
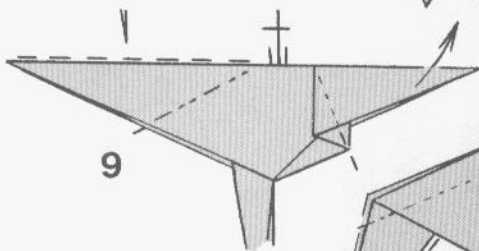
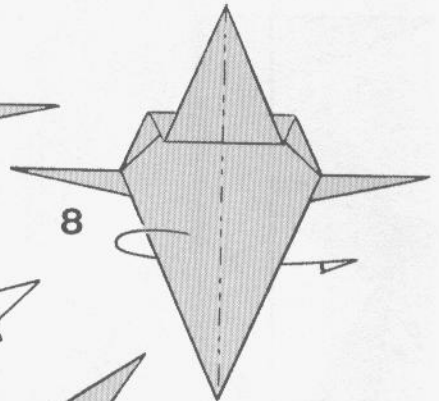
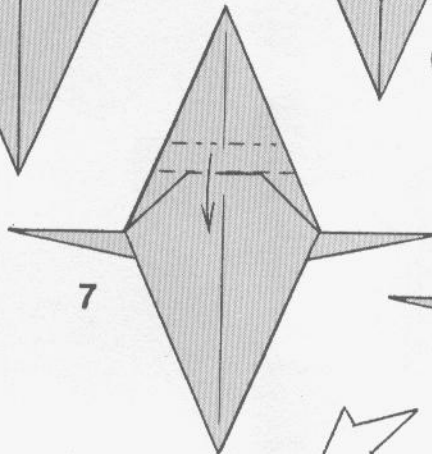
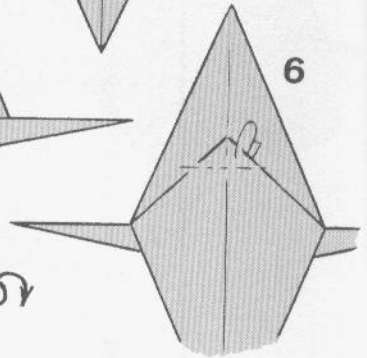
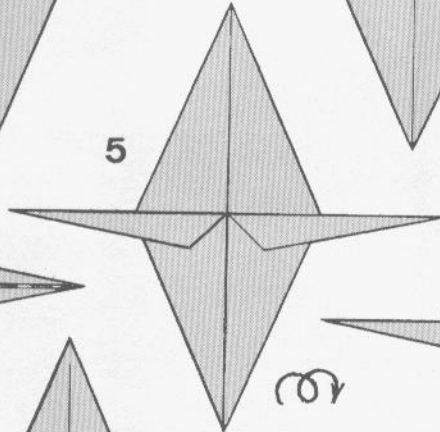
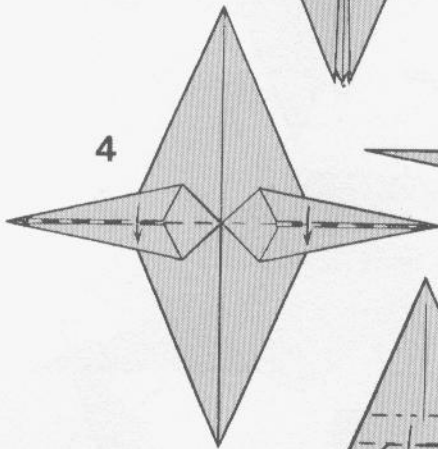
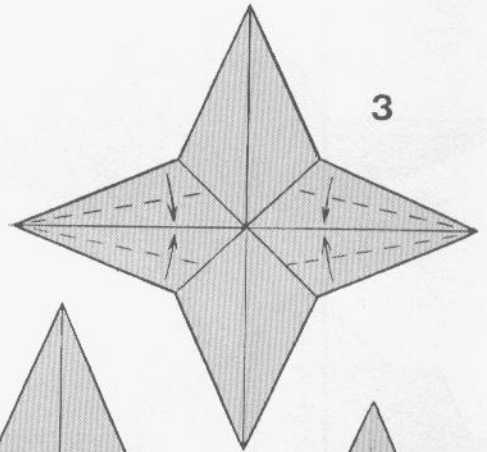
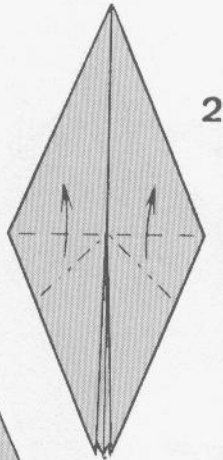
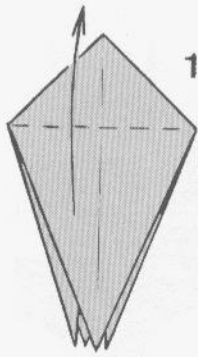

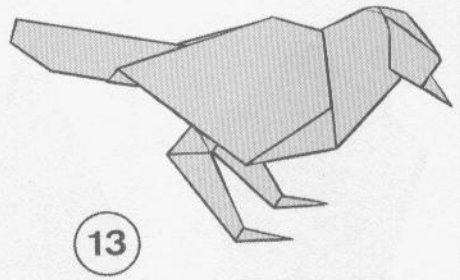
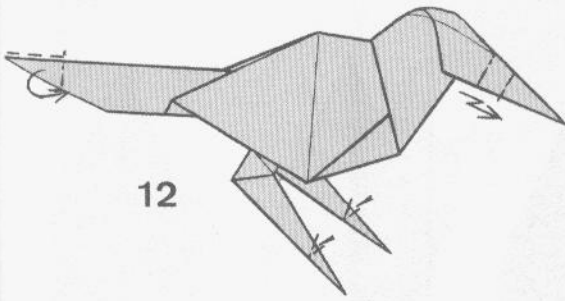

FIVE-SIDED BOX

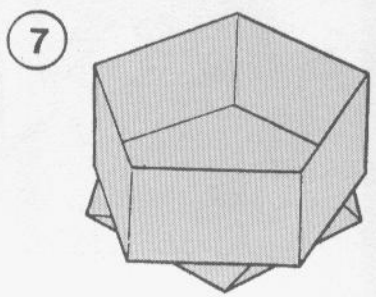
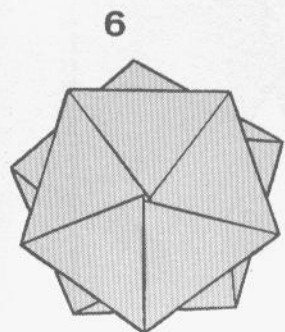
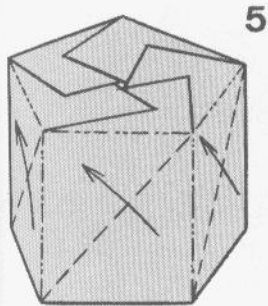
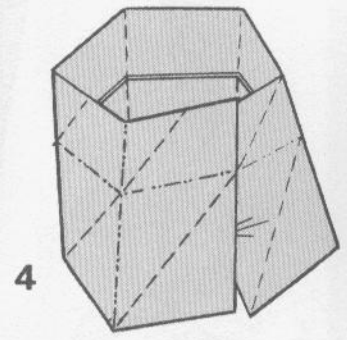
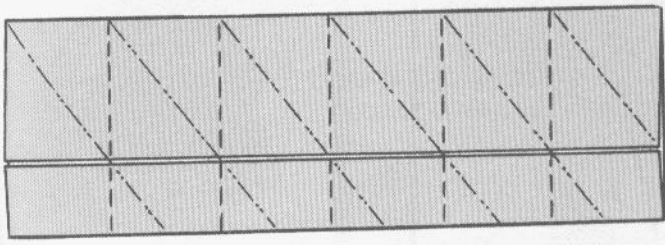
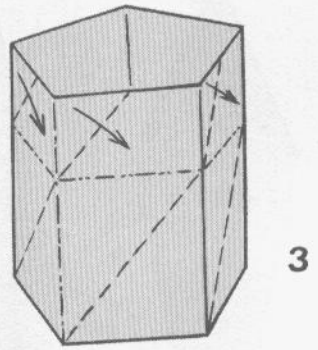
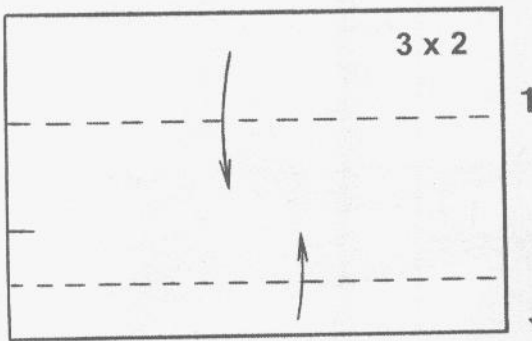

FROG

Traditional

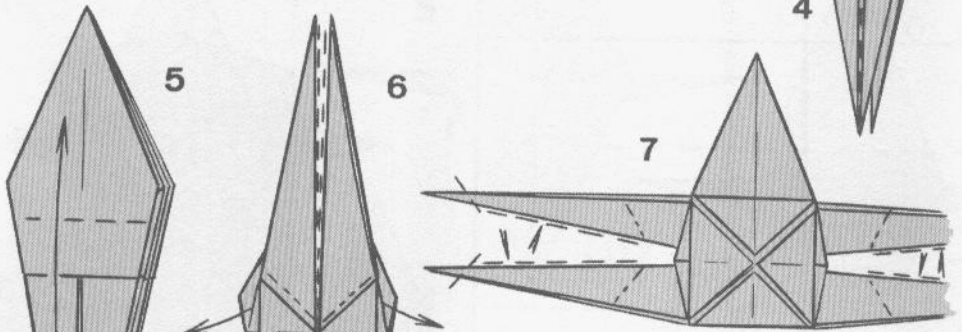
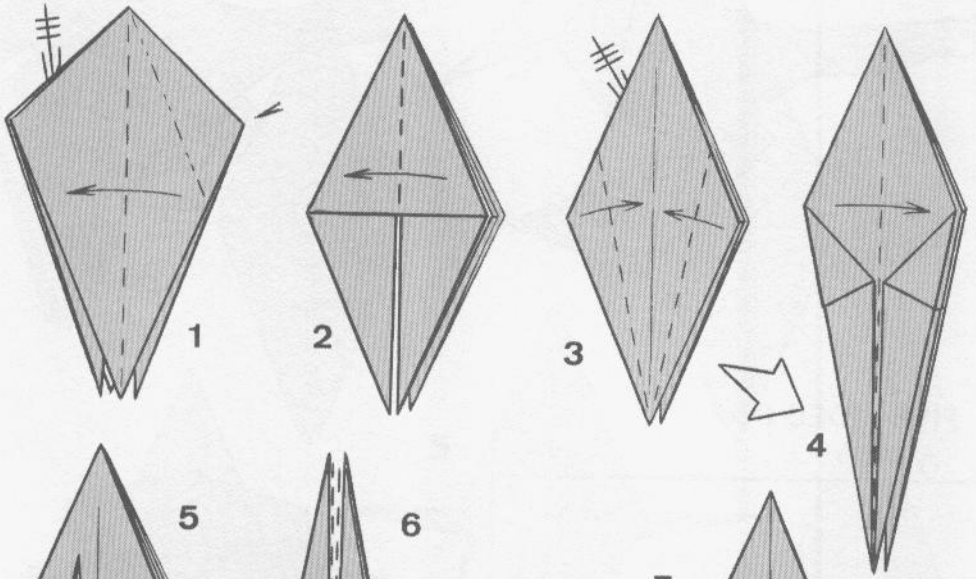

VARIANT OF THE FROG
BY KAN-NO-MADO

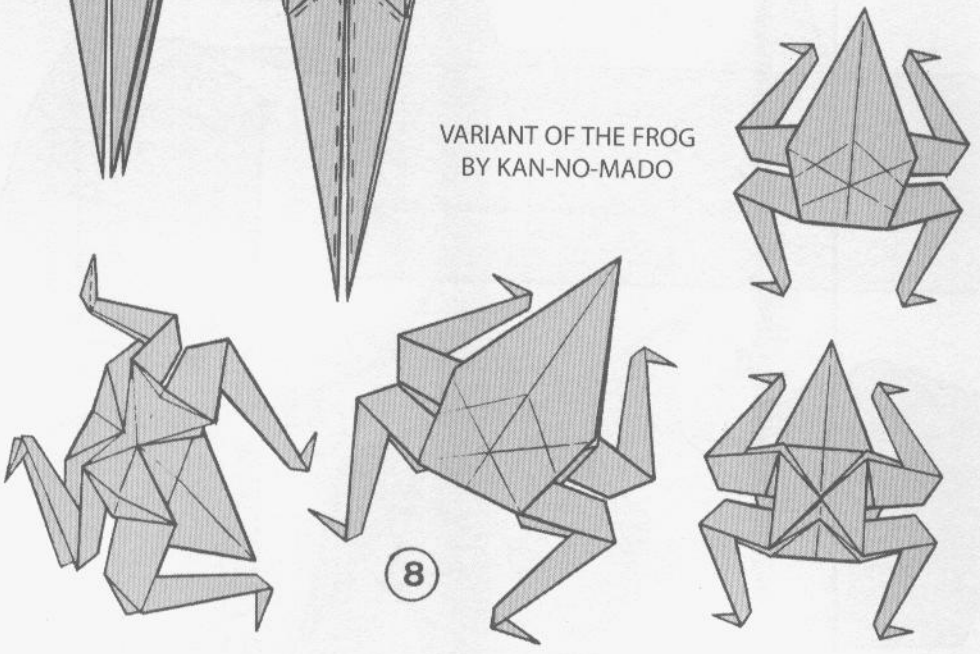

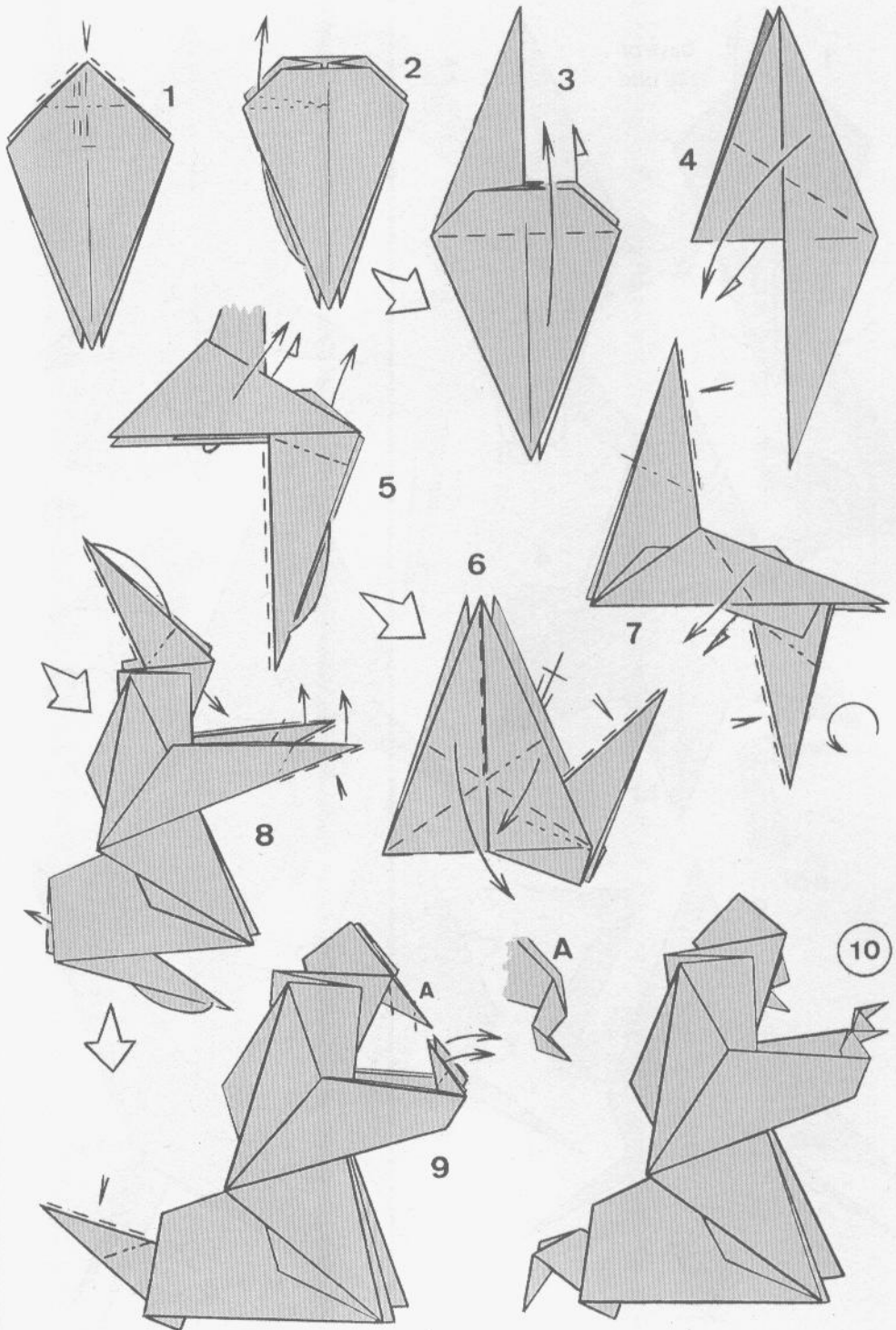

STORK

by Luis Fernández

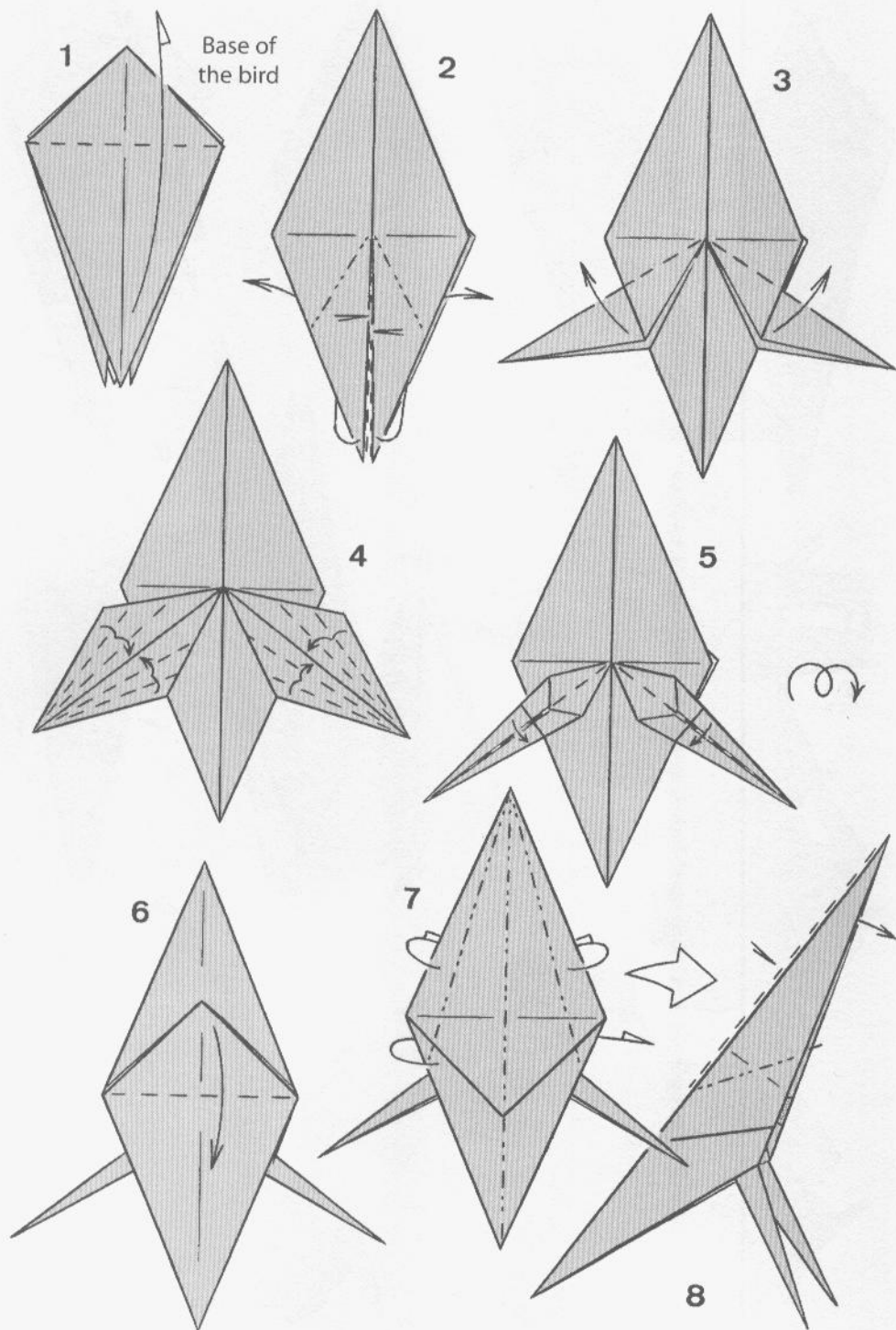

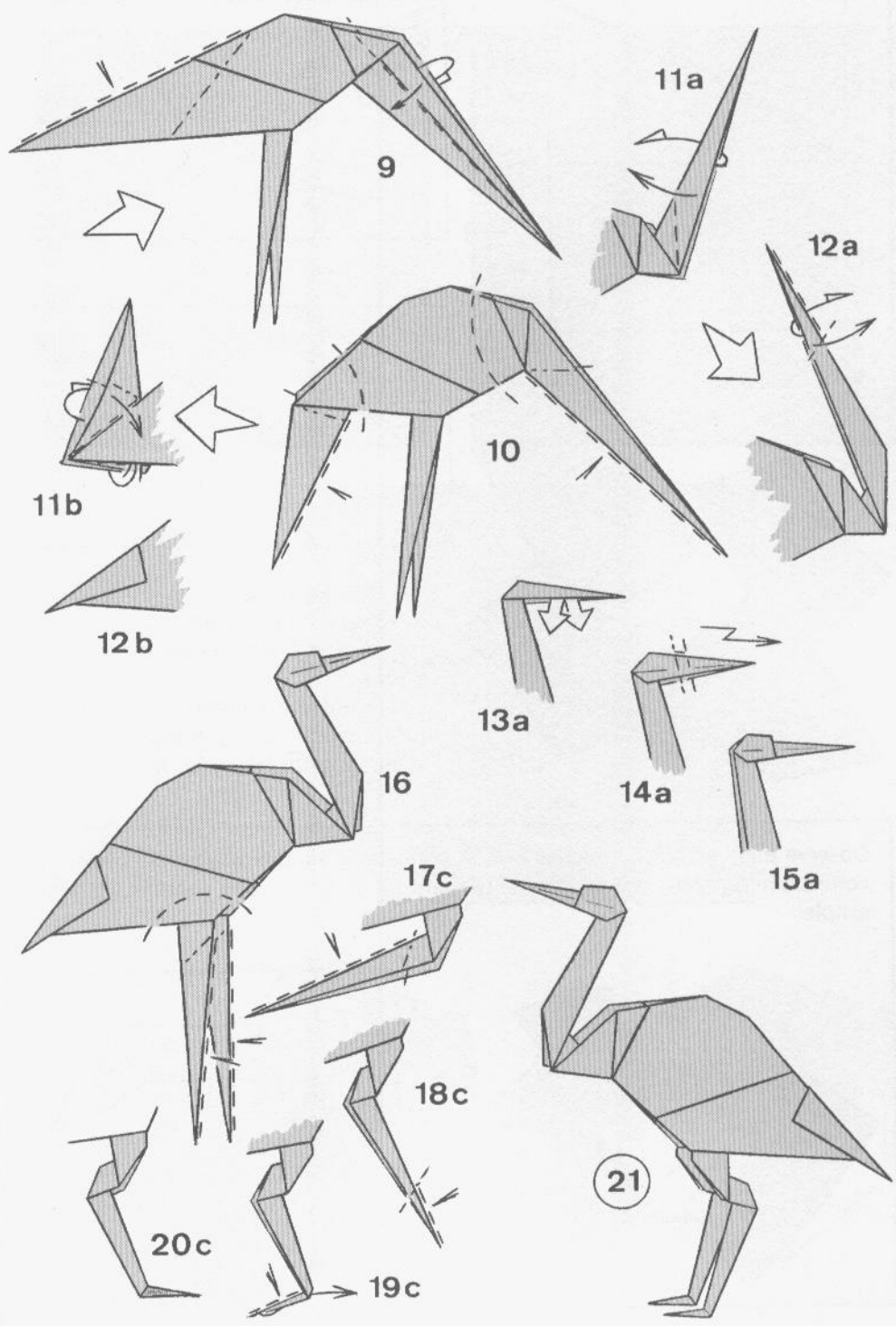

CRYSTAL

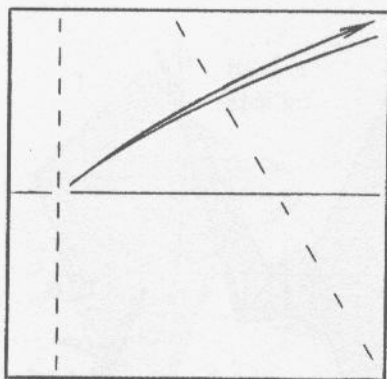

✂ 1:1√3
Thick paper

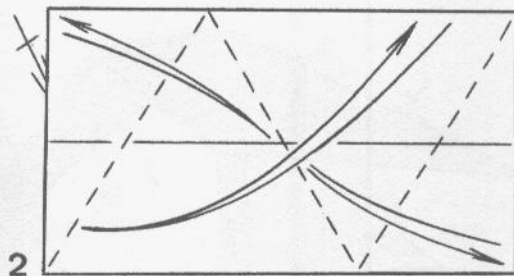

2

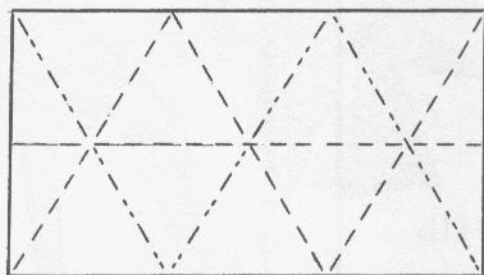

3

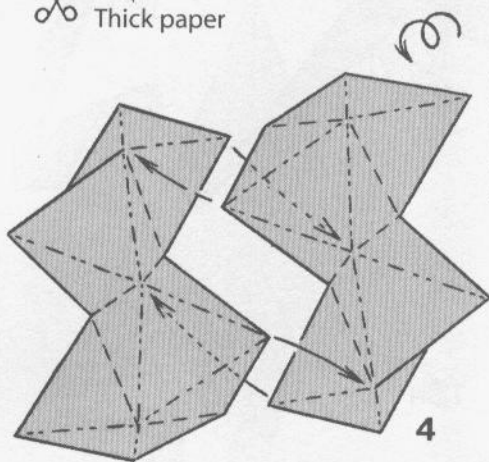

4

1. Fold 4 equal modules.
2. When 2 modules are put together, half of the final model is formed.
3. In the same way, form the other half, with the other 2 modules.
4. Put together the 2 halves.

Observe that each face, which is half an equilateral triangle, always fits below its corresponding complete-equilateral-triangle face, of the other module. It's very simple!

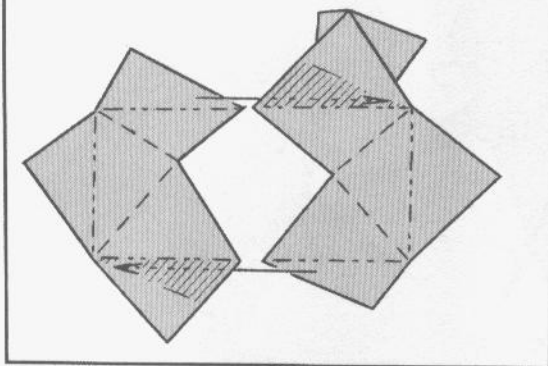

5

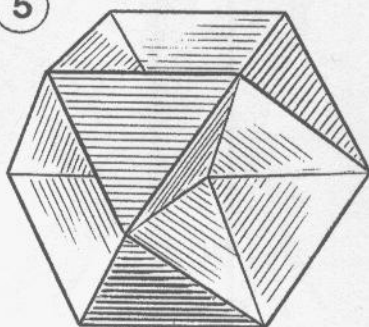

CUBIC BOX

by José Meeusen

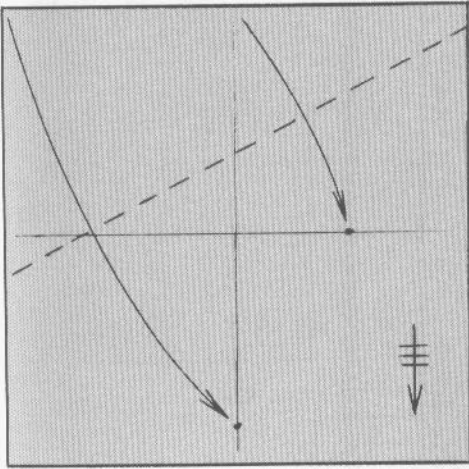

1

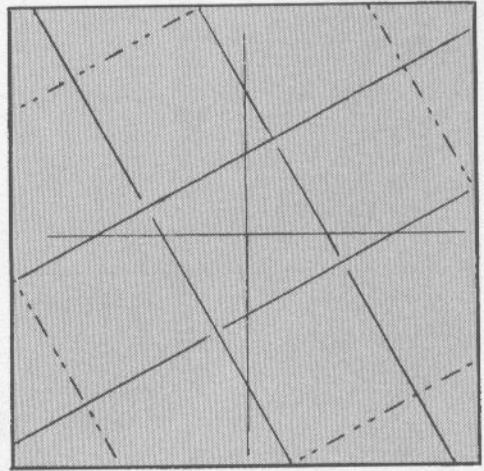

2

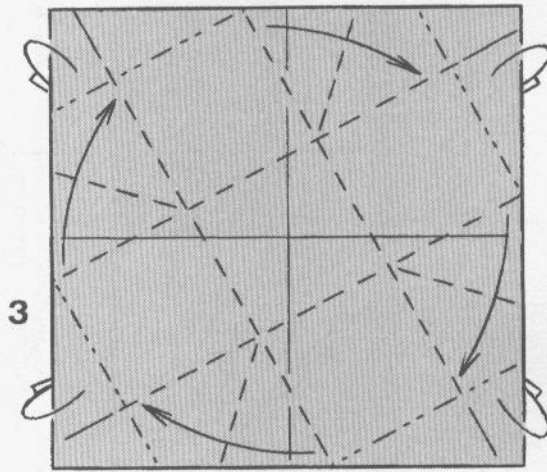

3



4

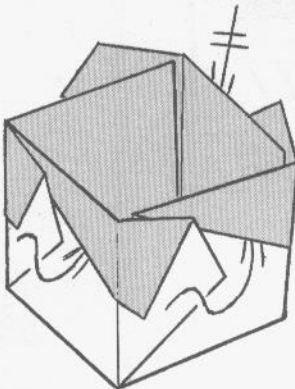

5

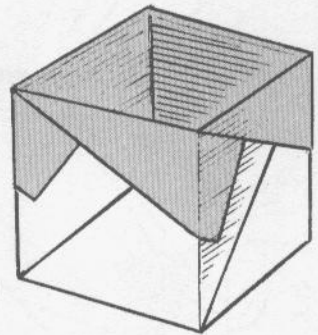

PERSIAN SLIPPERS

by Karen Reeds

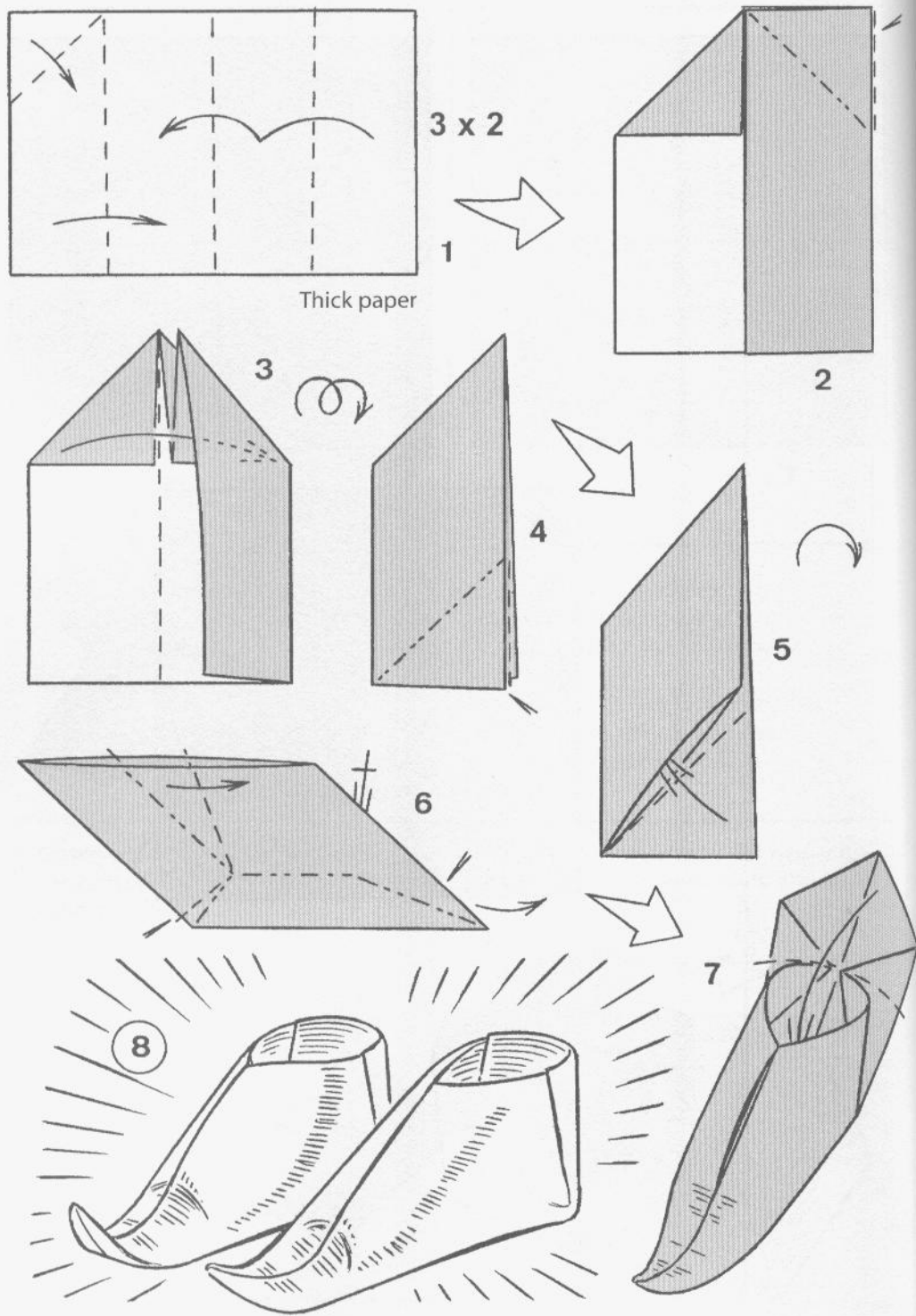

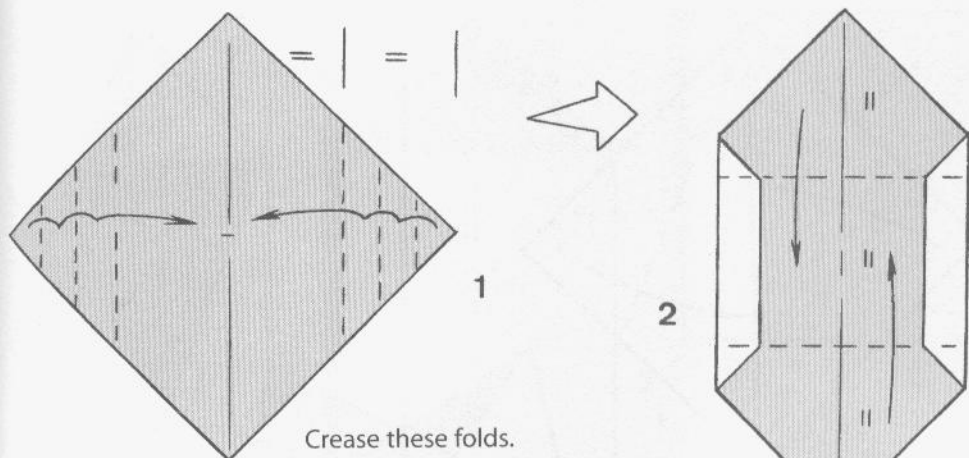

Crease these folds.

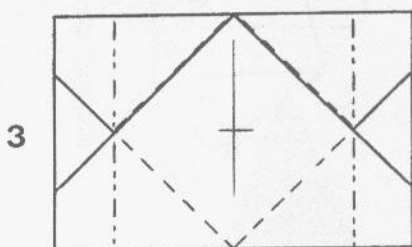

The folding of the lips:

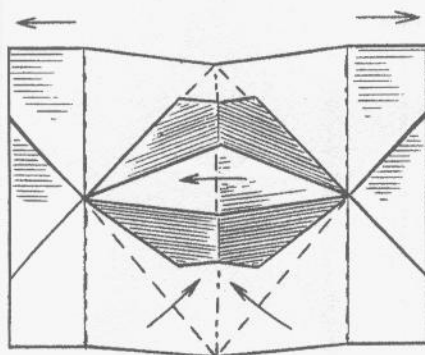
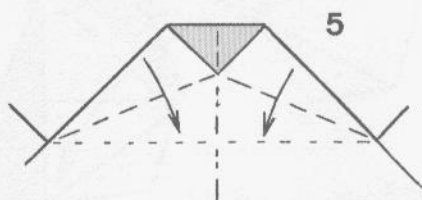
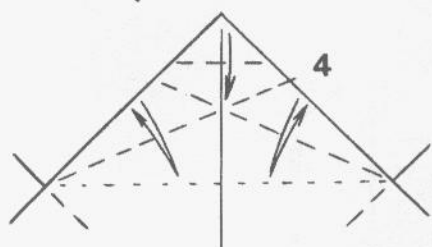

6

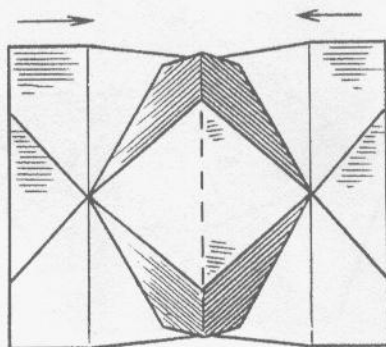

FIVE-POINT MODULAR STAR

by José Meeusen

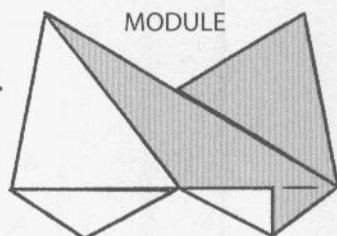
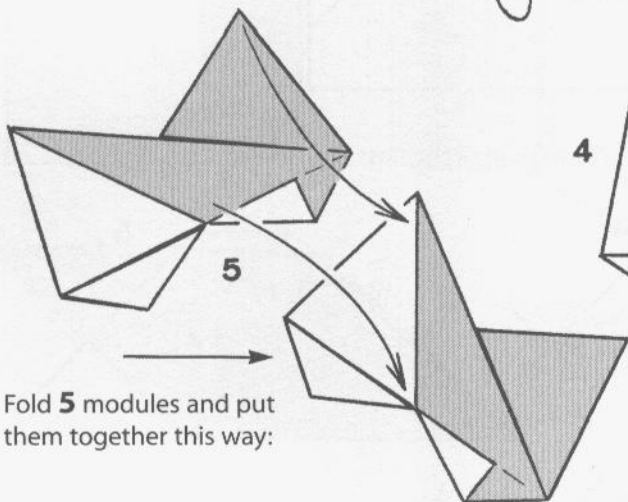
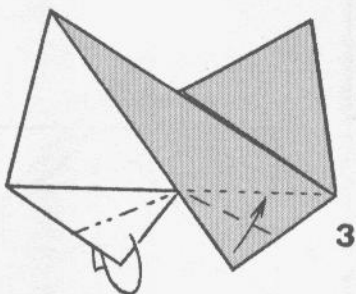
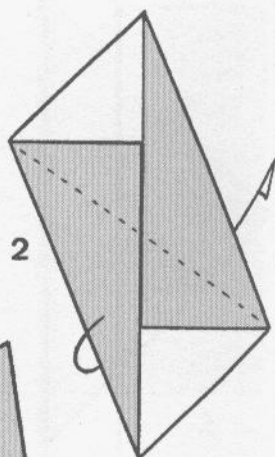
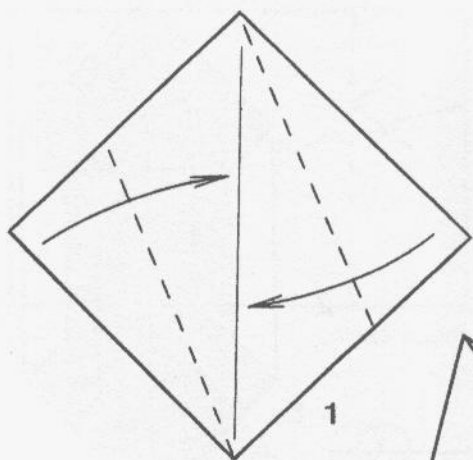

Fold **5** modules and put them together this way:

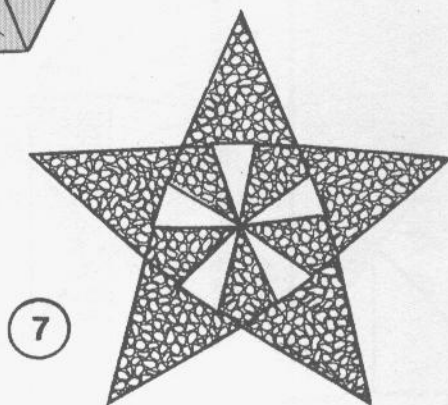
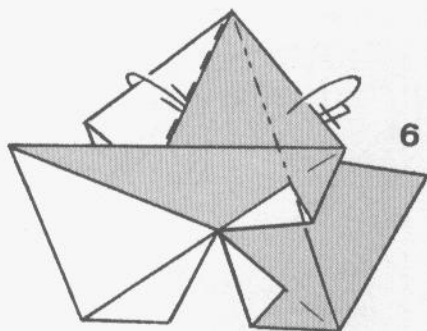

FIVE-POINT (or Six-Point) STAR

Traditional

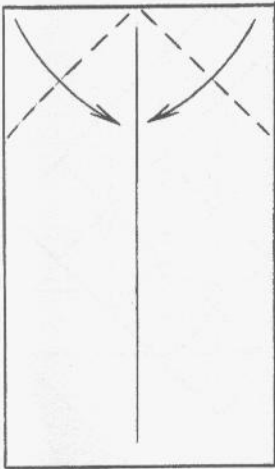

8.5 x 5

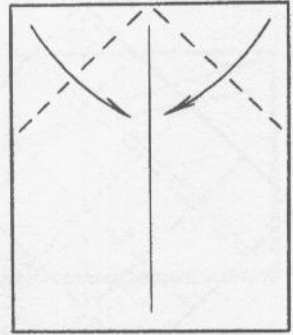
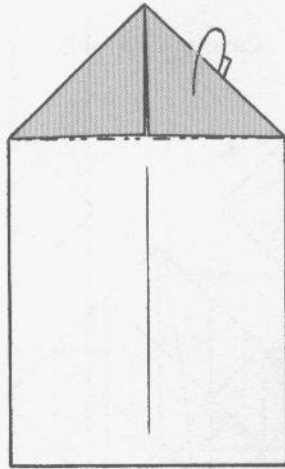

2

3

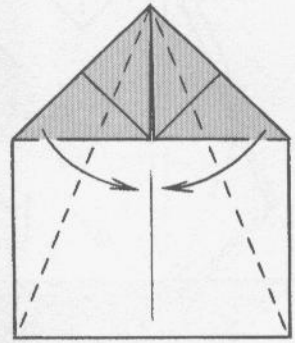

4

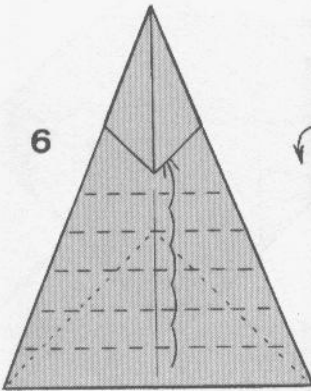

6

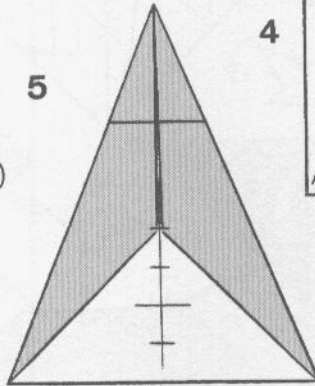

5

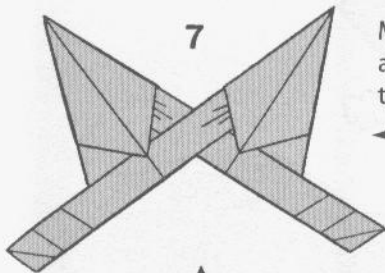

7

Make 5 equal modules and put them together this way:

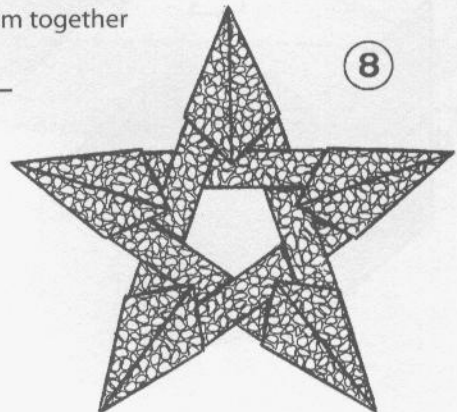

8

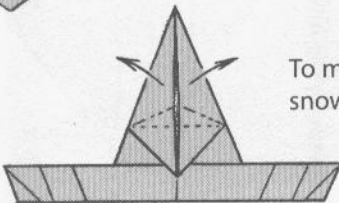

To make the snowflake.

Crease these folds.

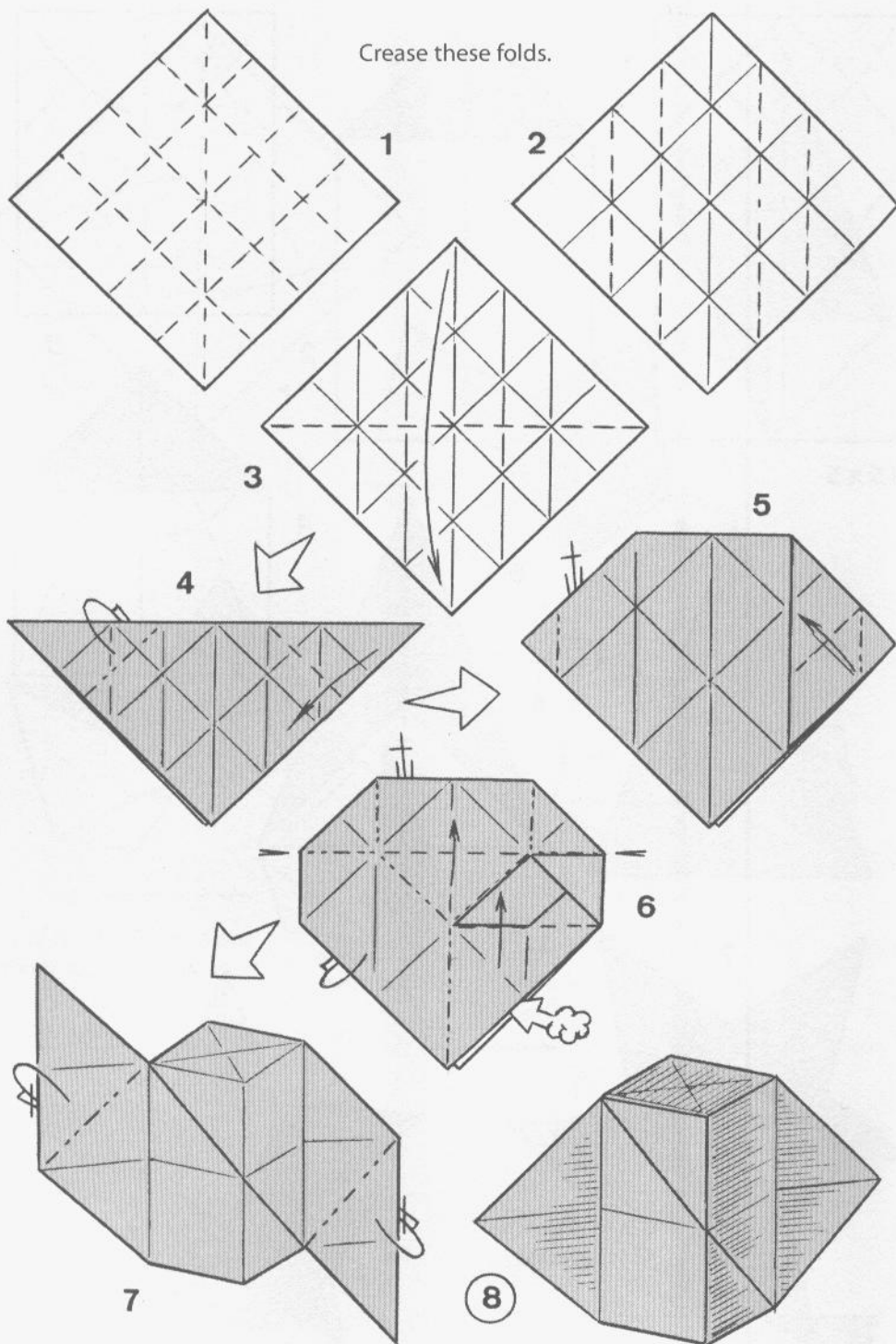

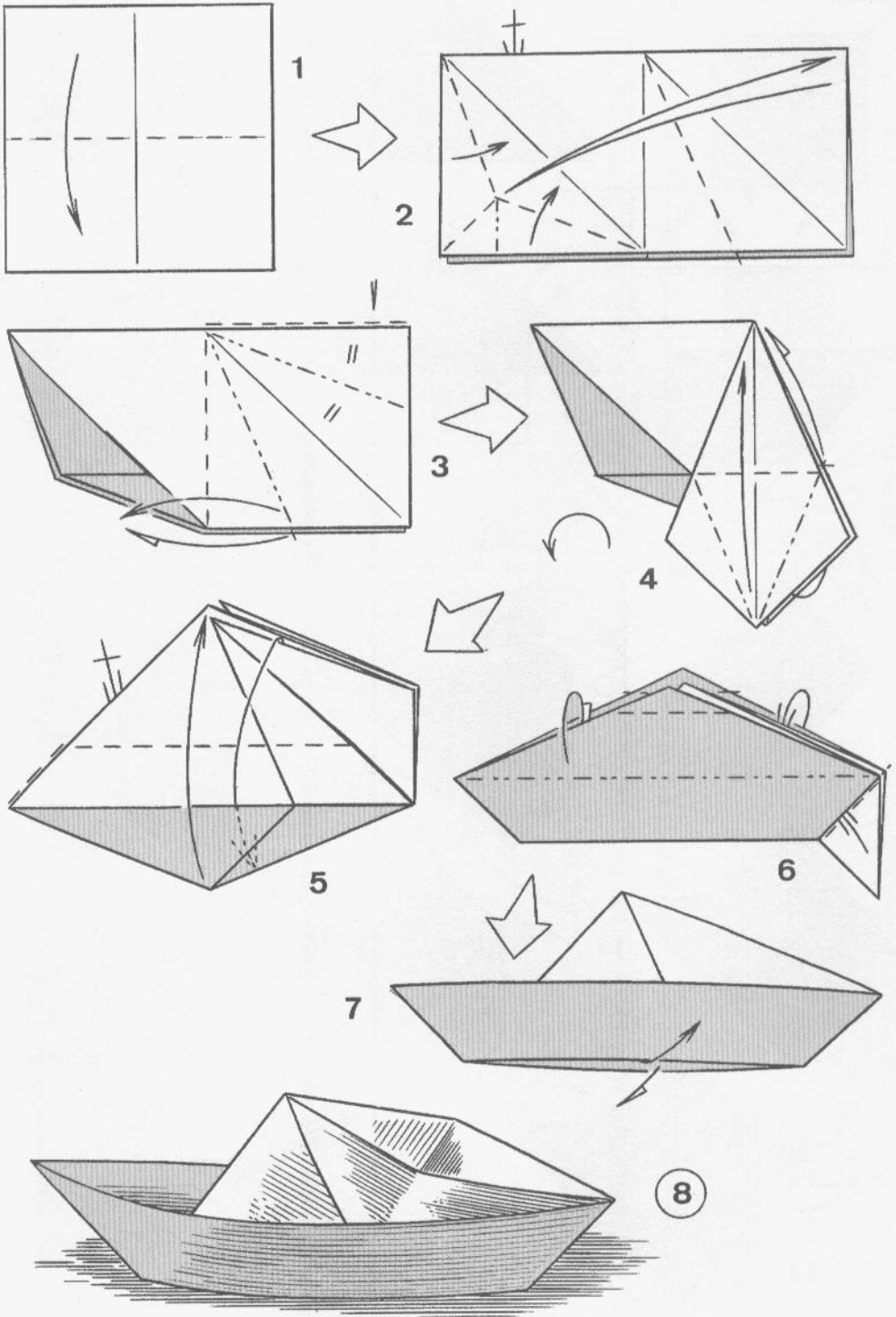

JUG

by Lionel Albertino

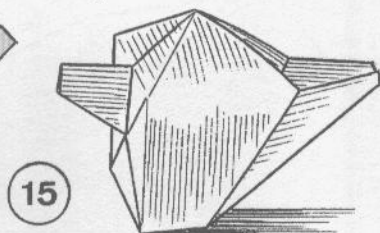
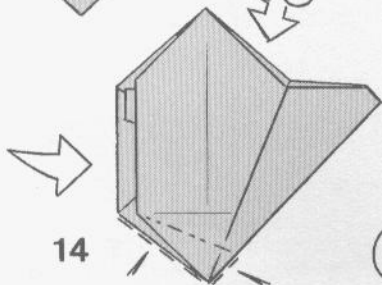
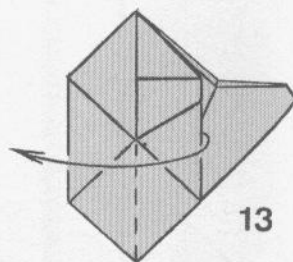
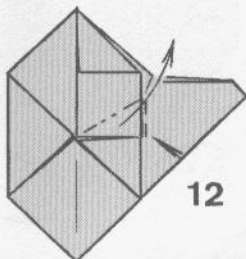
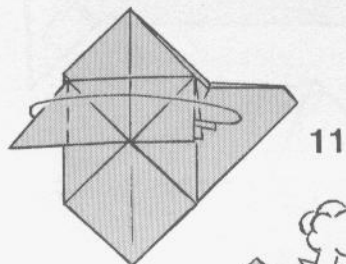
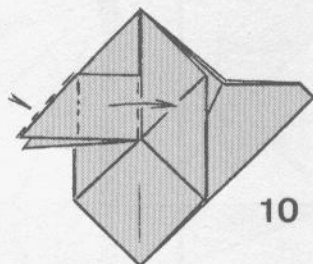
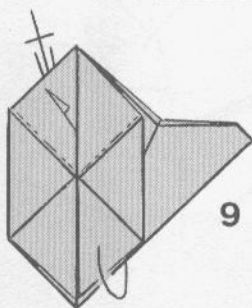
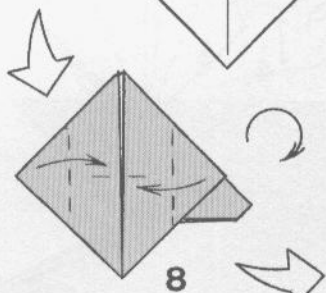
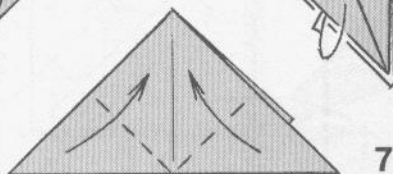
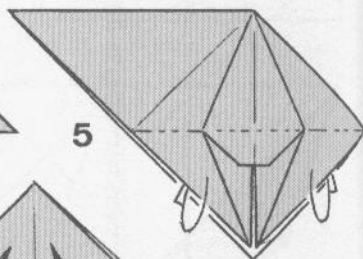
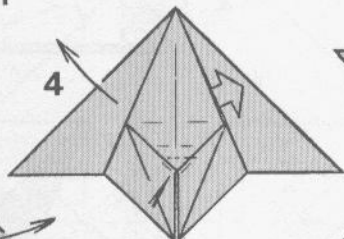
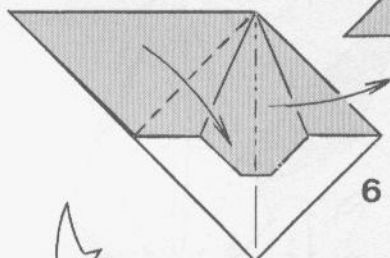
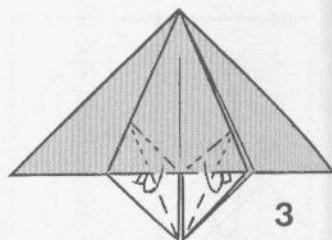
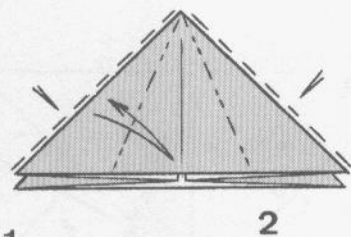
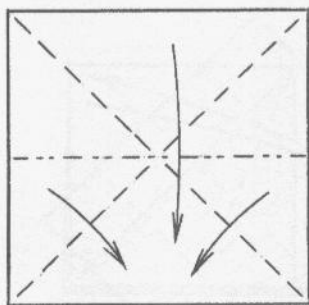

WHISTLE THAT WHISTLES (Assembled)

by Ángel Écija

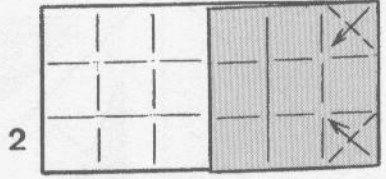
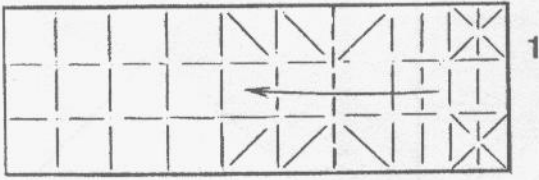

Best to use: 2.4 x 7 in.

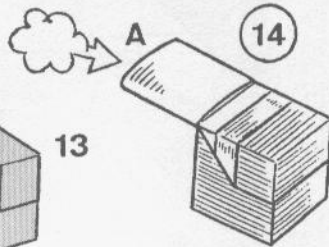
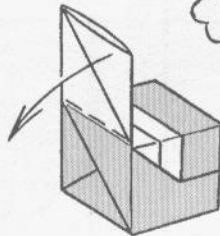
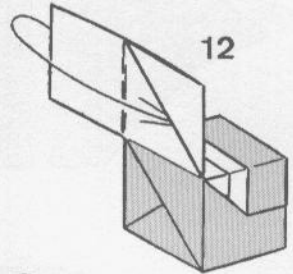
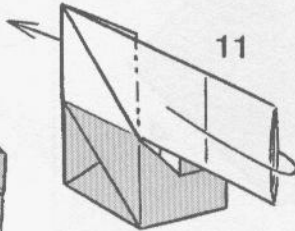
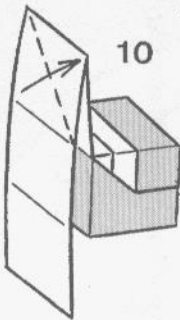
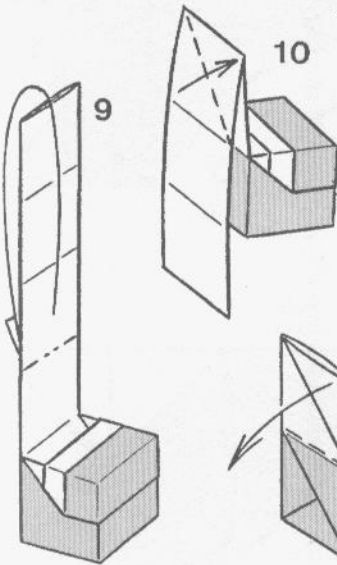
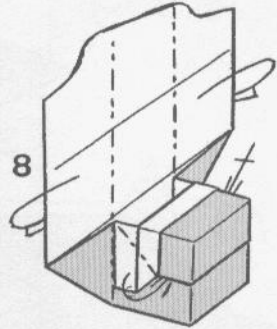
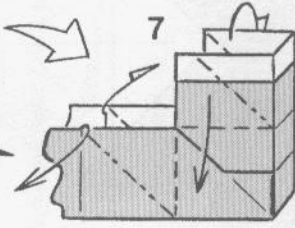
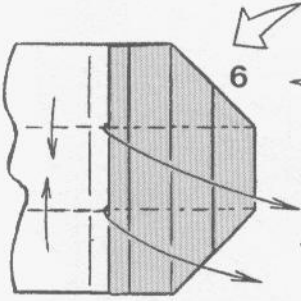
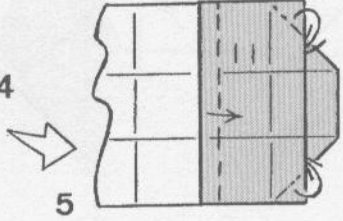
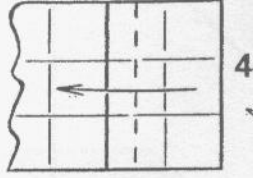
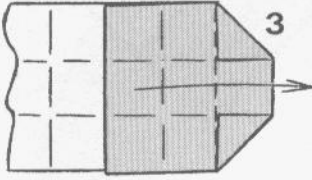

Spread out the mouthpiece on side A and give it the proper angle.

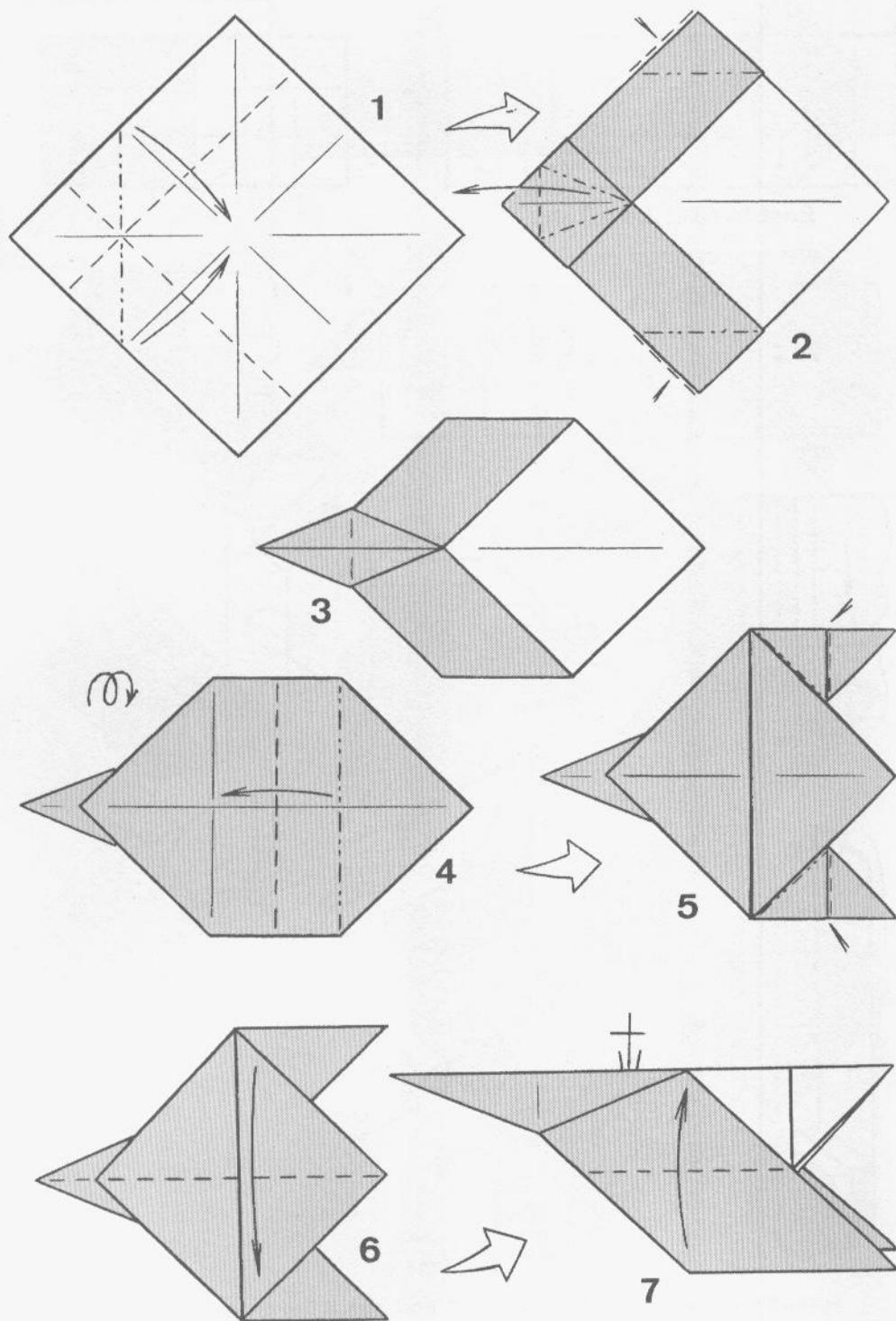

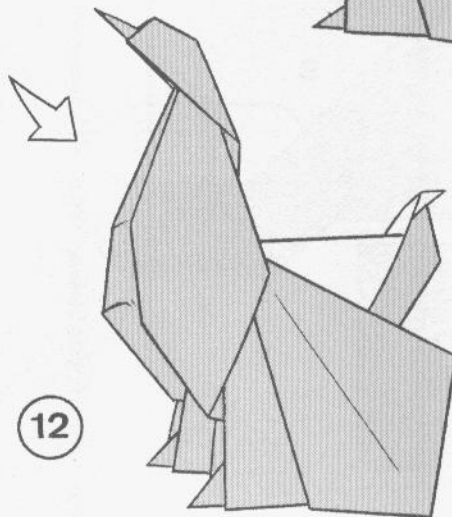
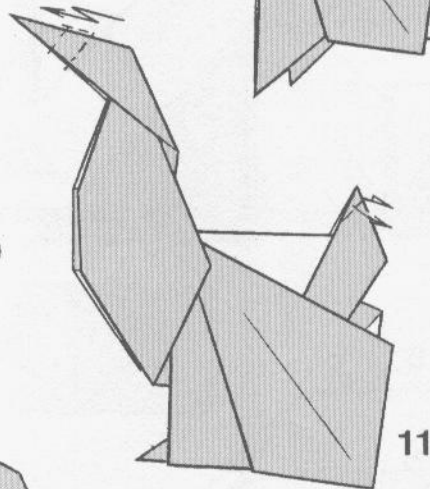
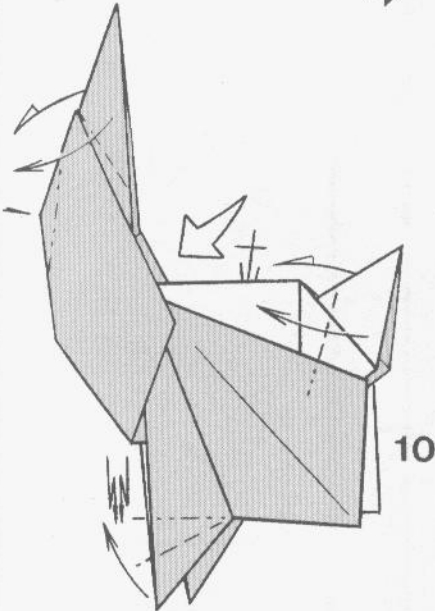
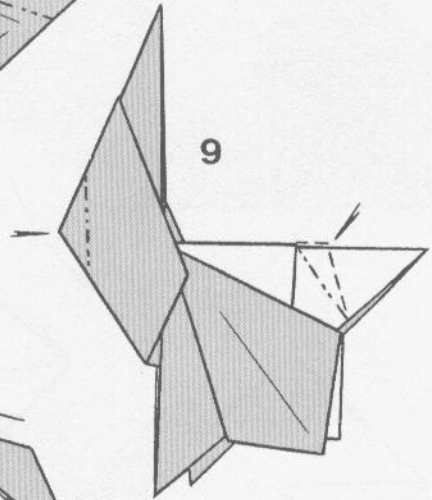
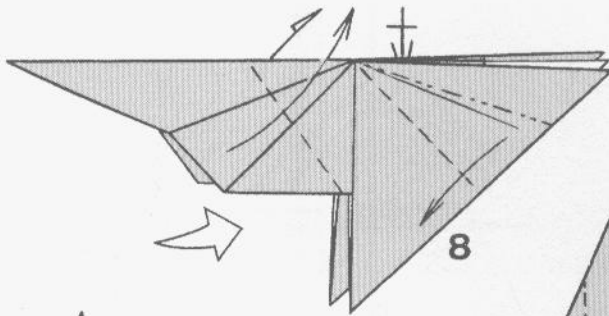

IRREVERSIBLE-PROCESS BOX by Tim Ward and Trevor Hatchett

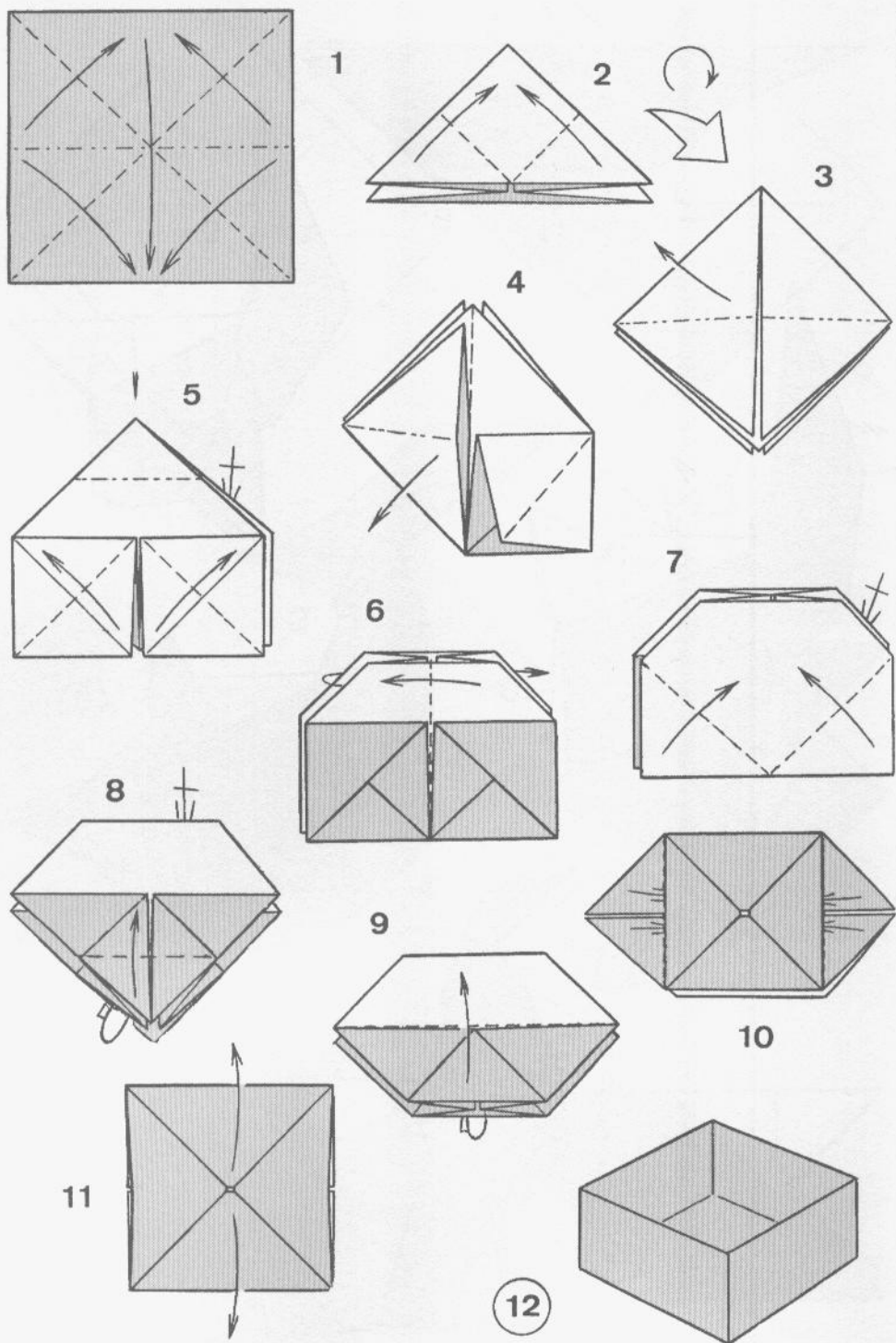

MODULAR CROWN 1

by Miguel Ángel Palacios

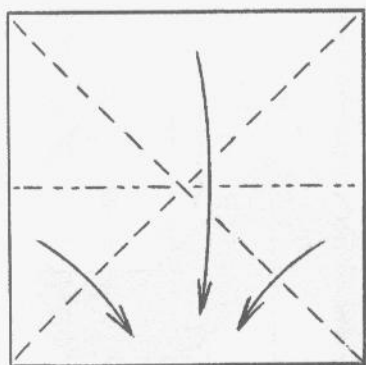

1

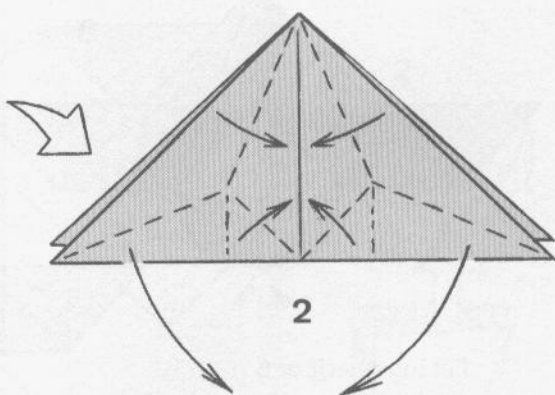

2

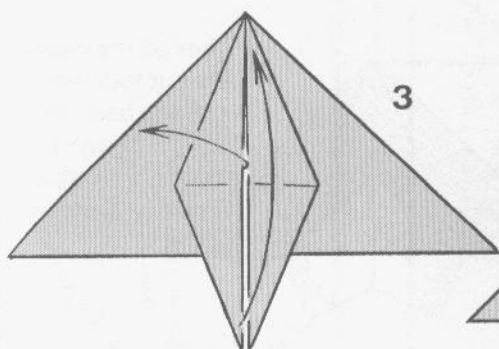

3

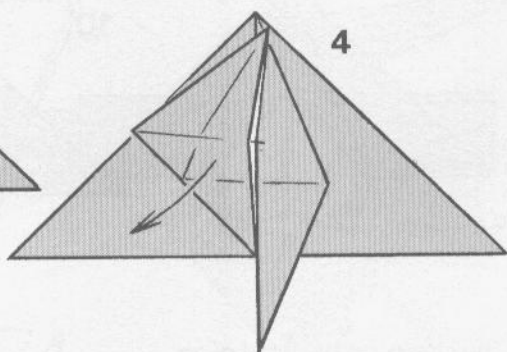

4

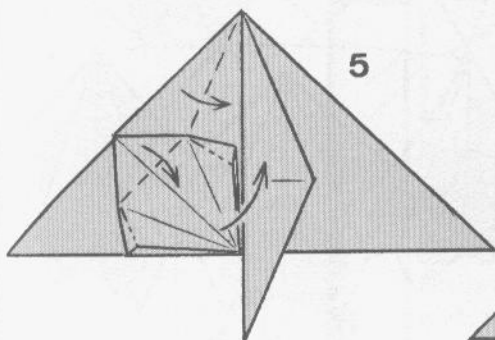

5

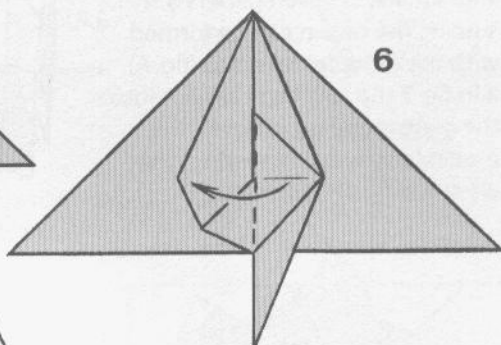

6

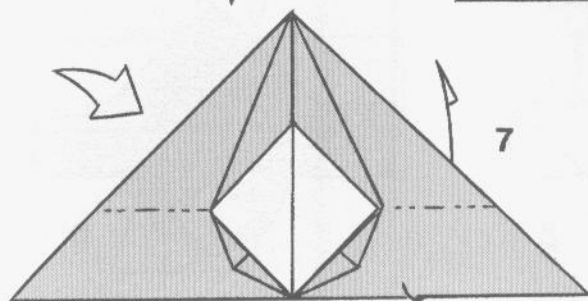

7

After fig. 6,
repeat steps
3, 4, 5, and 6
on the other side.

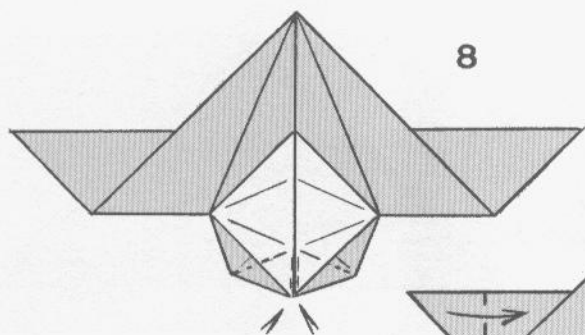

8

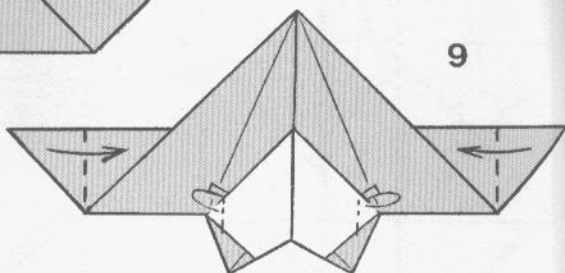

9

Put together 7 or 8 modules this way:

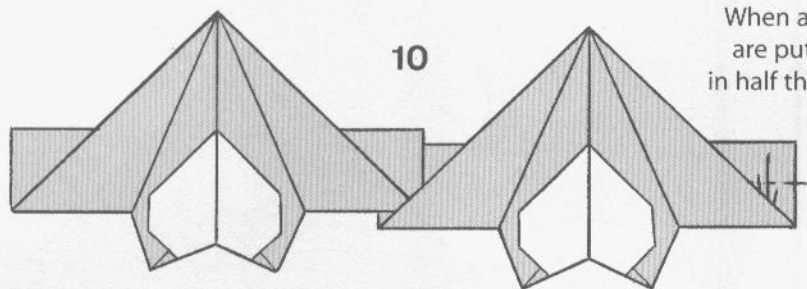

10

When all the modules are put together, fold in half the back strip, as shown in the adjacent drawing.

The crown, for the head of an adult, may require eight papers 7 in. square, or seven papers 8¼ in. square. The crown can be formed with the modules inverted (fig. A). If in fig. 7 the two flaps are put into the corresponding grooves, the model (also very interesting) that we see in fig. B is formed.

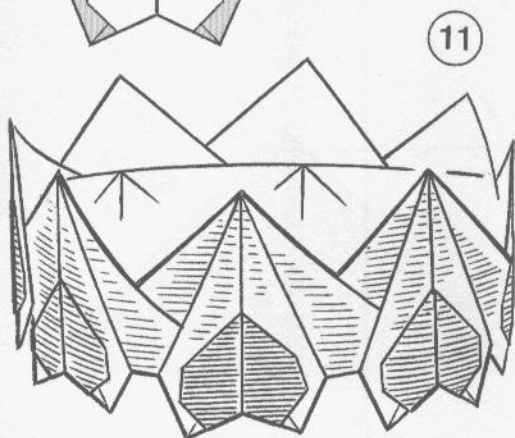

11

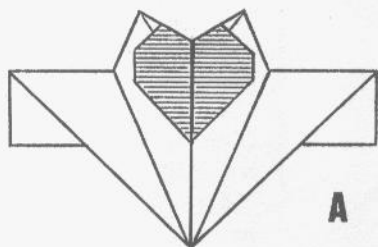

A

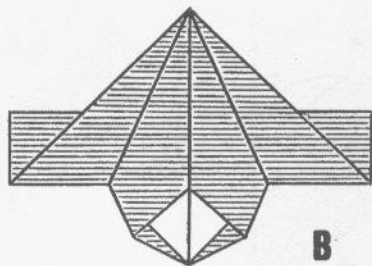

B

MODULAR CROSS

by Jeff Beynon

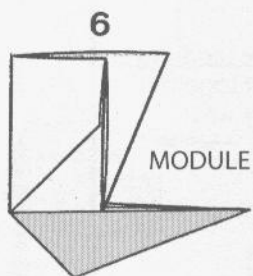
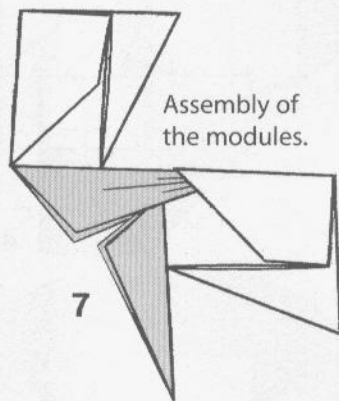
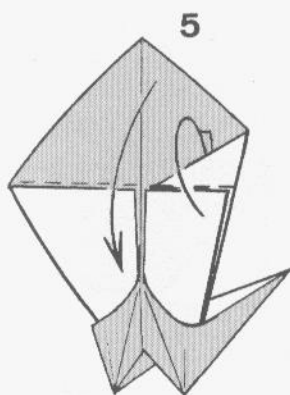
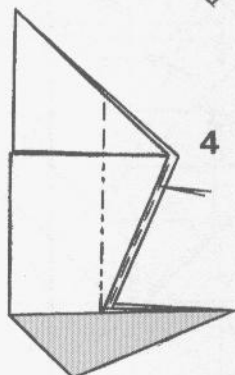
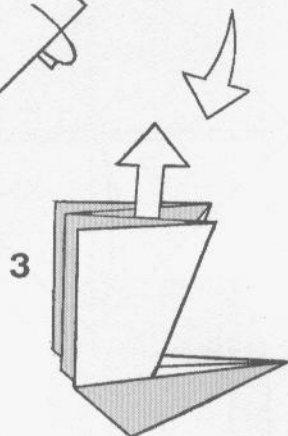
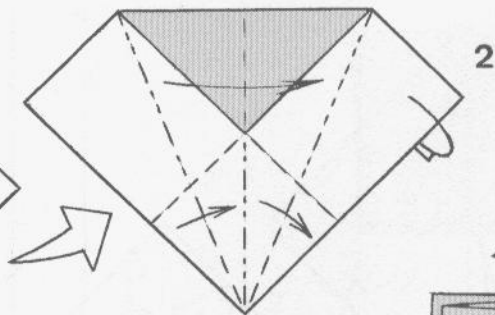
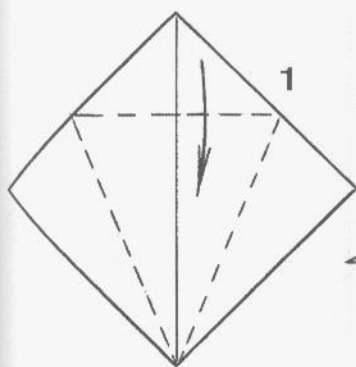

Make 4 equal modules.

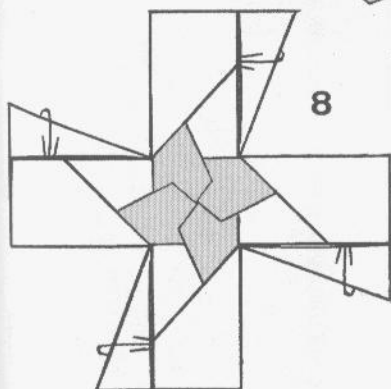

8 The reverse side is identical!

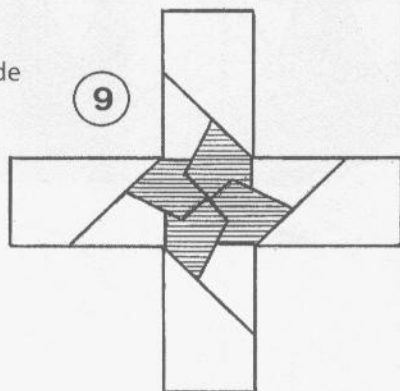

MODULAR CROWN 2

by Eugenio Fridrich

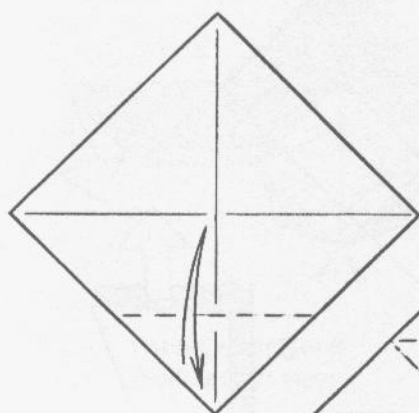

1

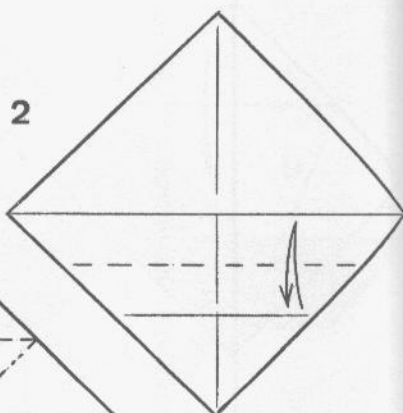

2

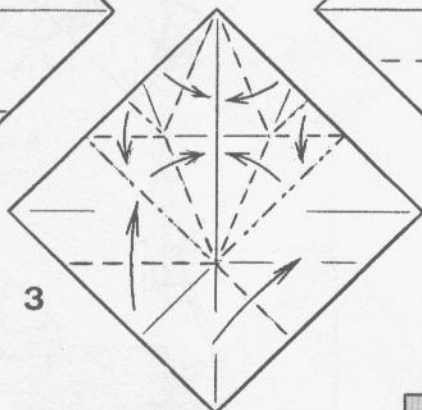

3

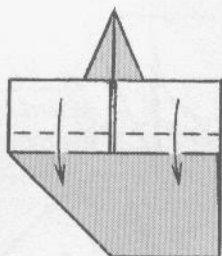

4

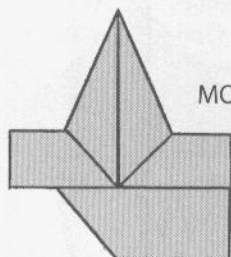

MODULE

5

The modules are put together this way:

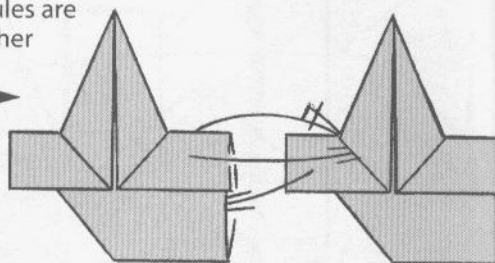

6

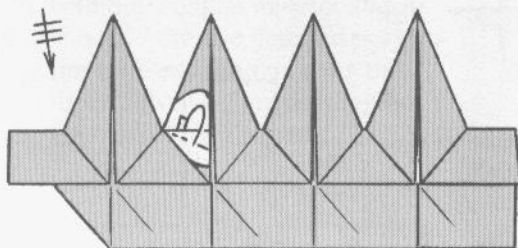

7



8

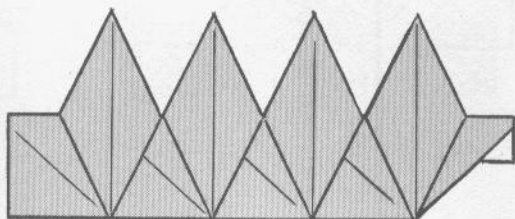

SIMPLE BOX

by Dr. Philip Shen

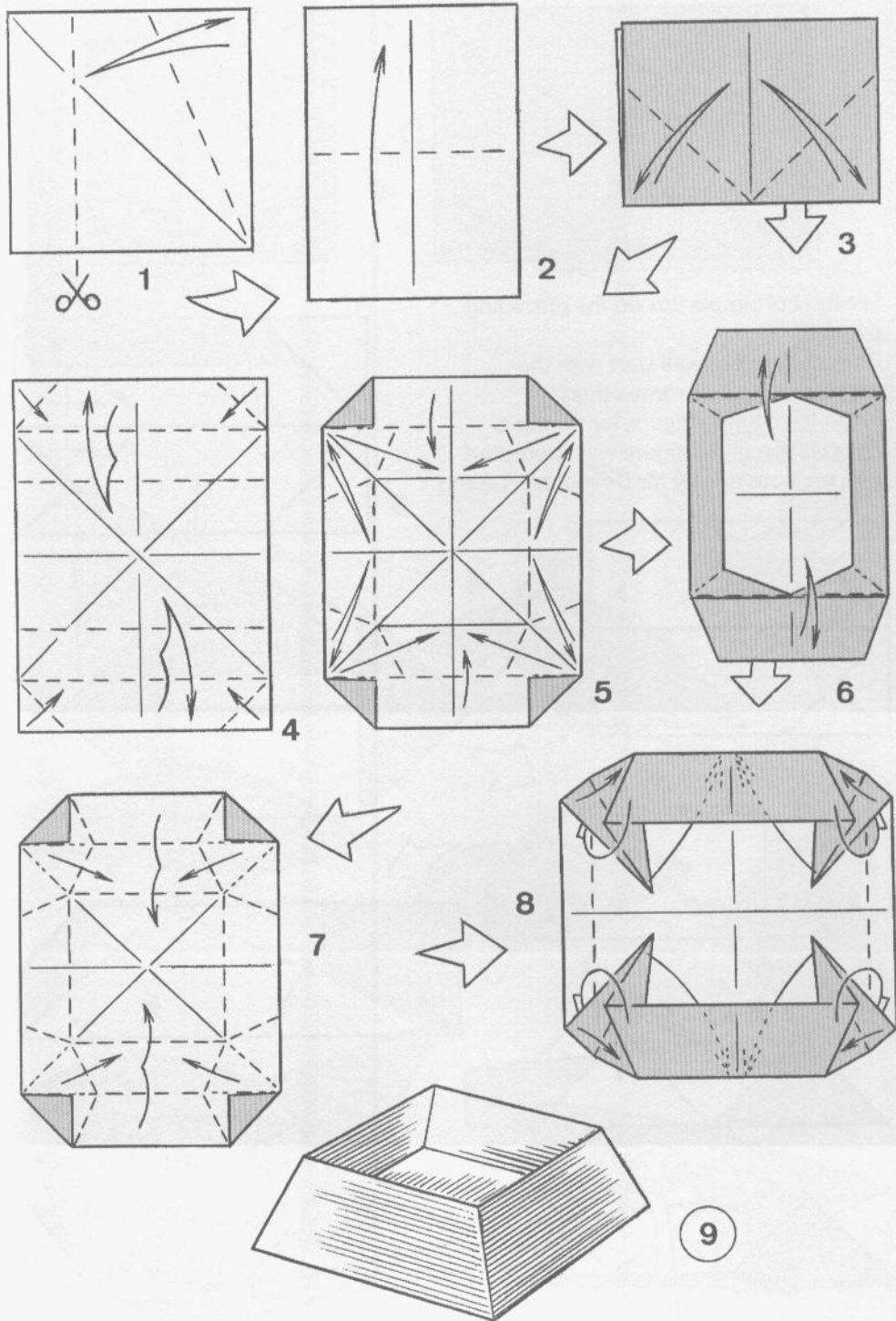

HOUSEBOAT

by Dr. Philip Shen

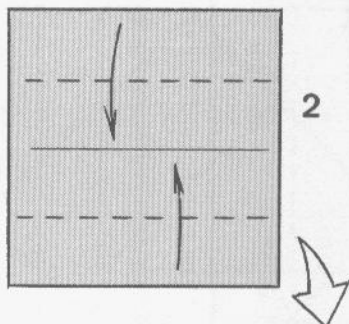
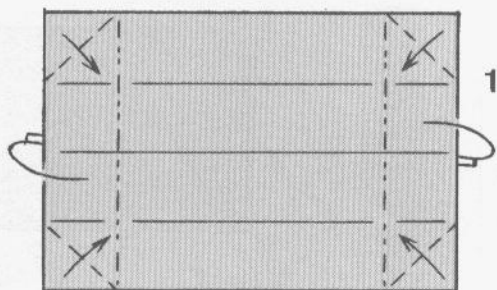

See fig. 2 of Simple Box on the preceding page.

One could just as well start with the proportion 3 x 2 or some others, obtaining a longer figure, for example. The creation of this figure was suggested by a previous one by Mr. Dokuohtei Nakano.

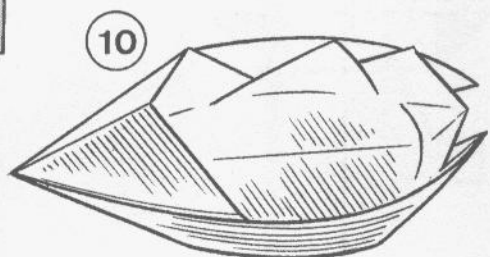
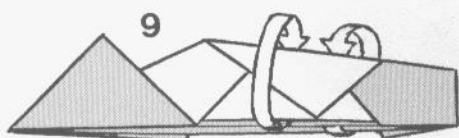
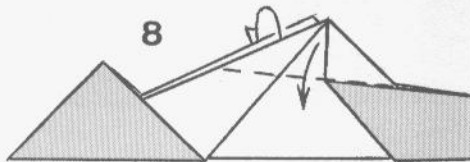
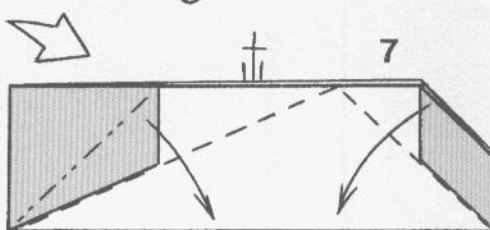
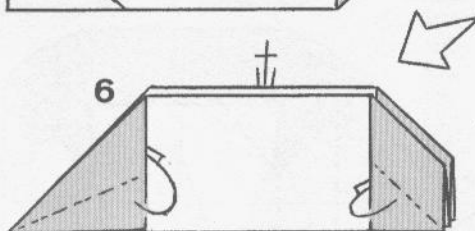
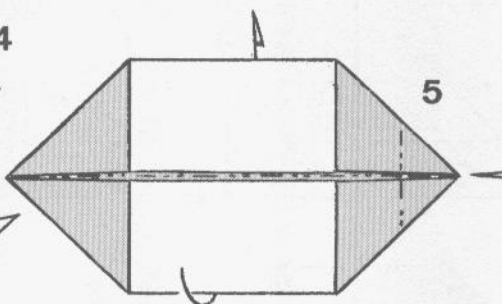
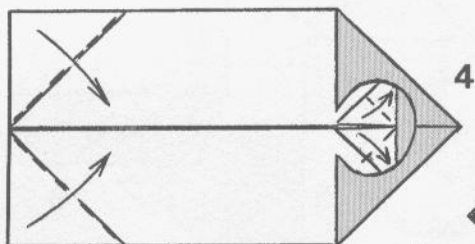
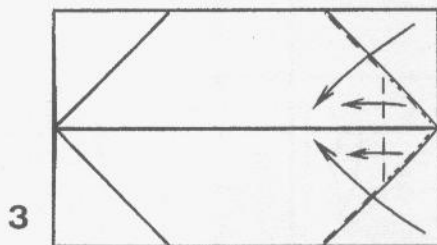

GOLDFISH

by Yoshihide Momotani

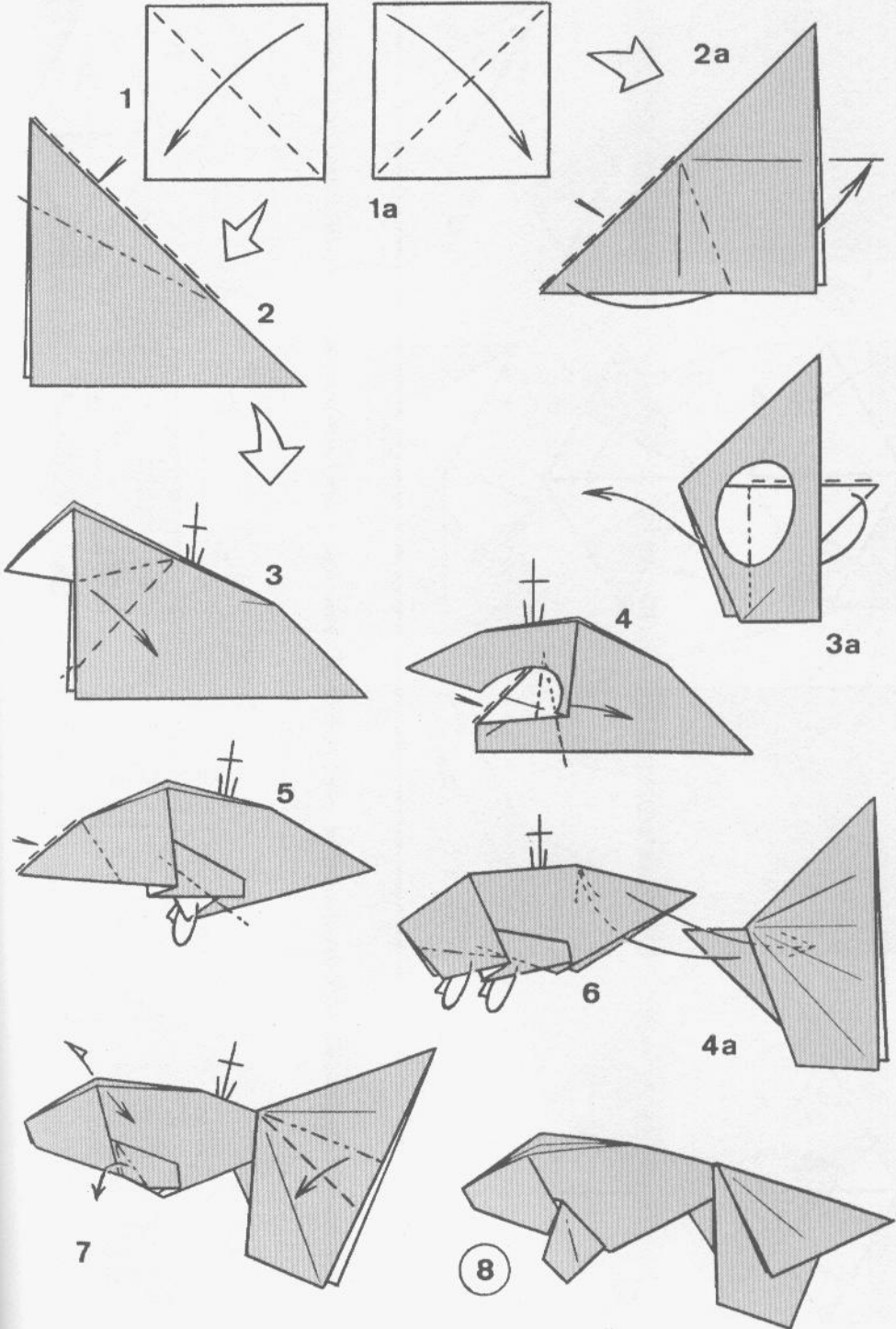

MODULAR DITETRAHEDRON

by Tomoko Fuse

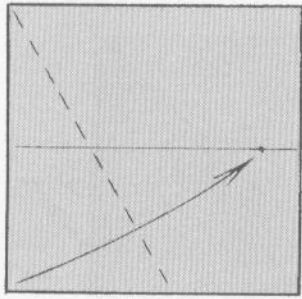

1

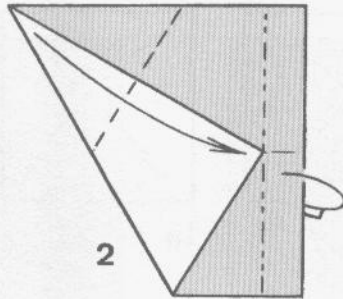

2

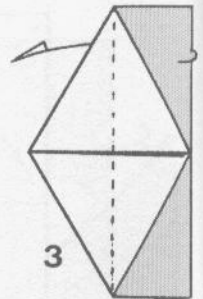

3

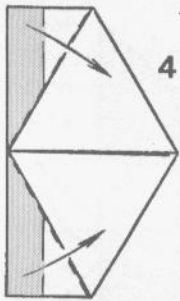

4

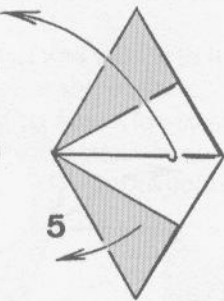

5

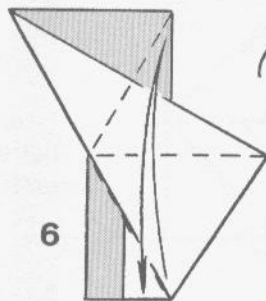

6

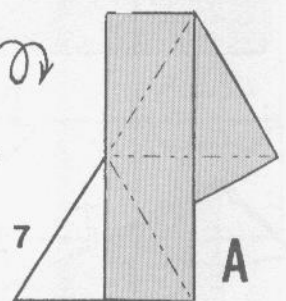

A

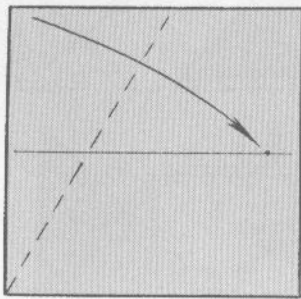

1

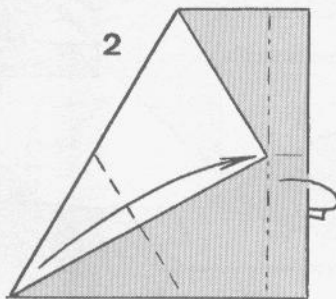

2

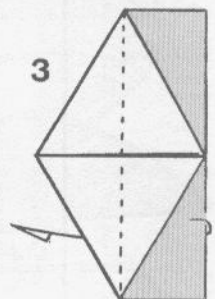

3

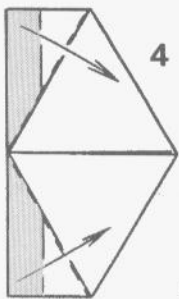

4

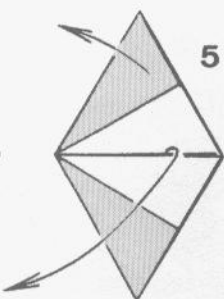

5

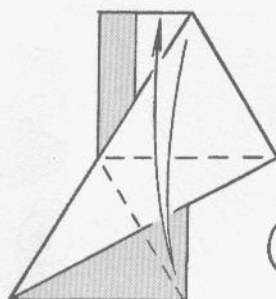

6

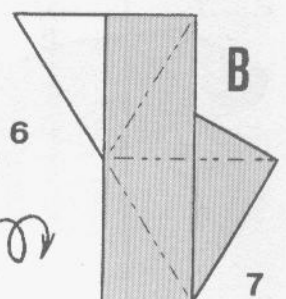

B

7

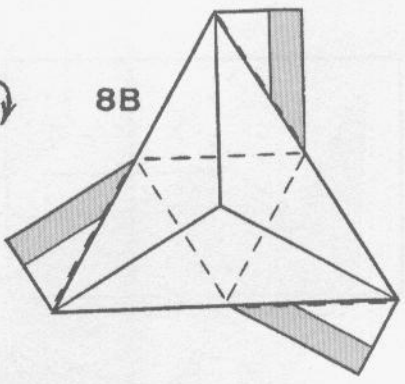
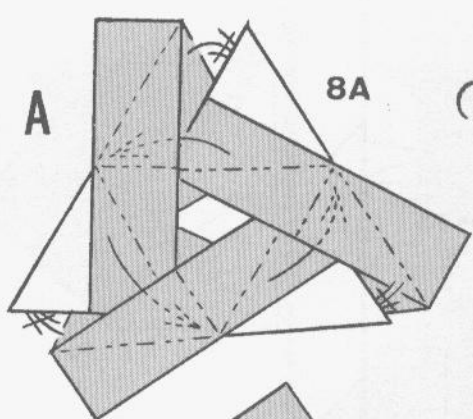

Make 2 inverted sets
of 3 modules each ...

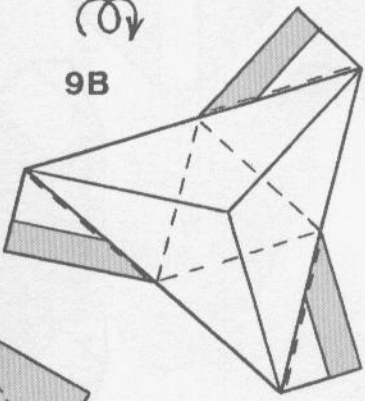
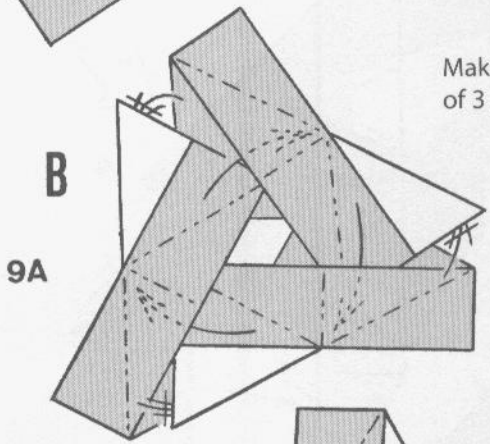

... and put them
together this way:

10

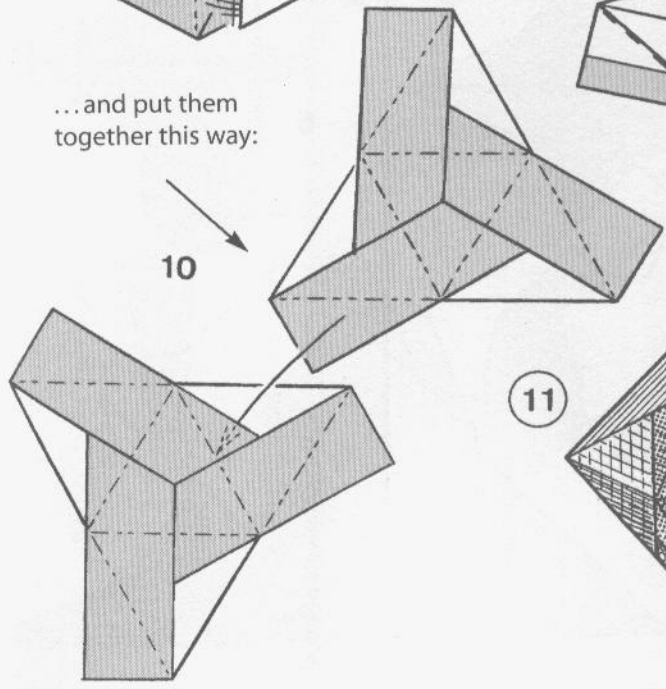

11

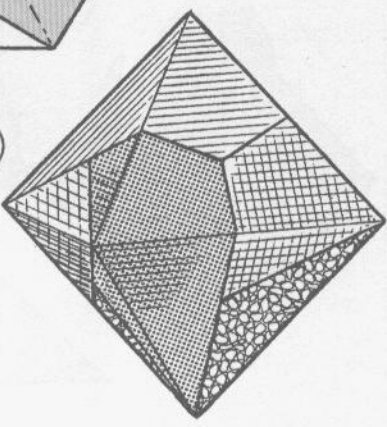

EAGLE

by Dr. V. Solórzano

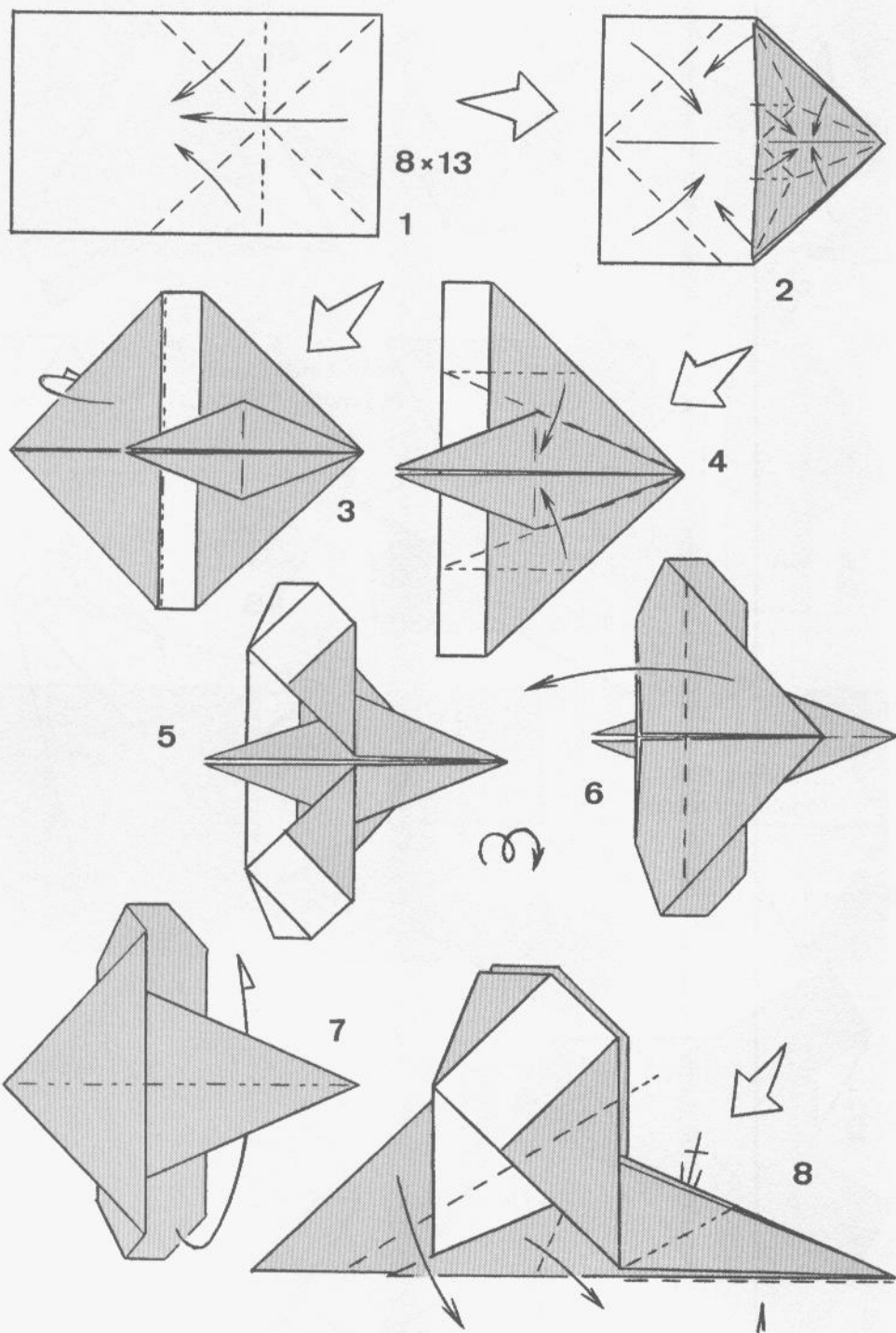

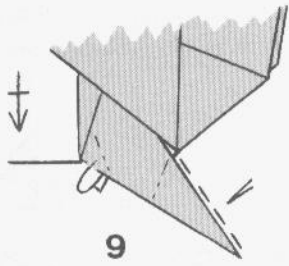

9

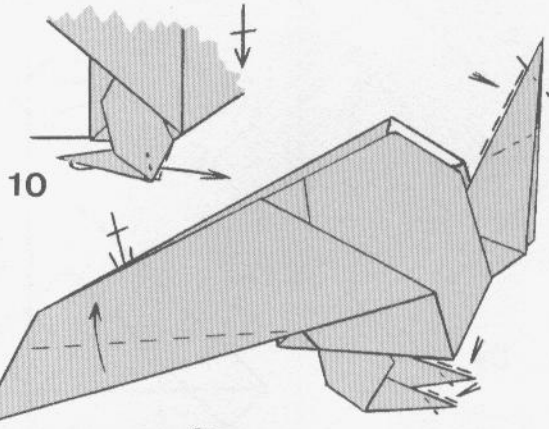

10

11

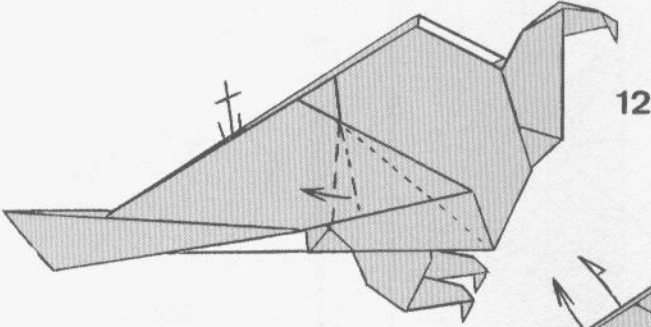

12

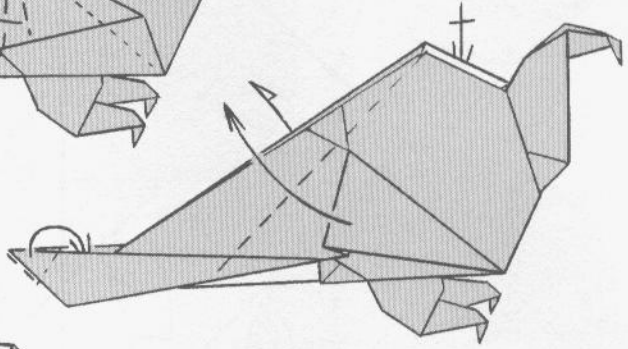

13

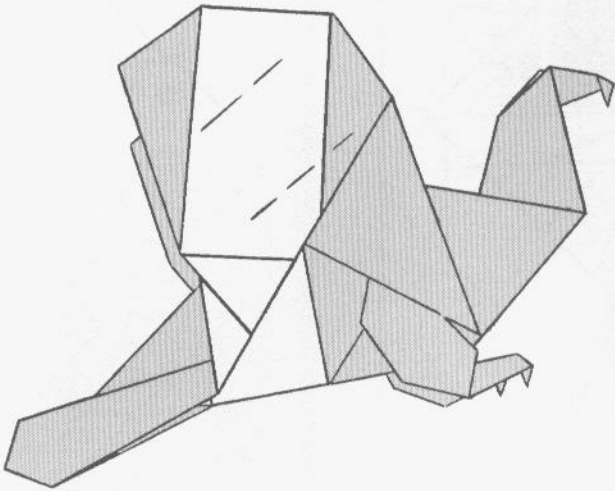

14

SNAIL SHELL

by Tomoko Fuse

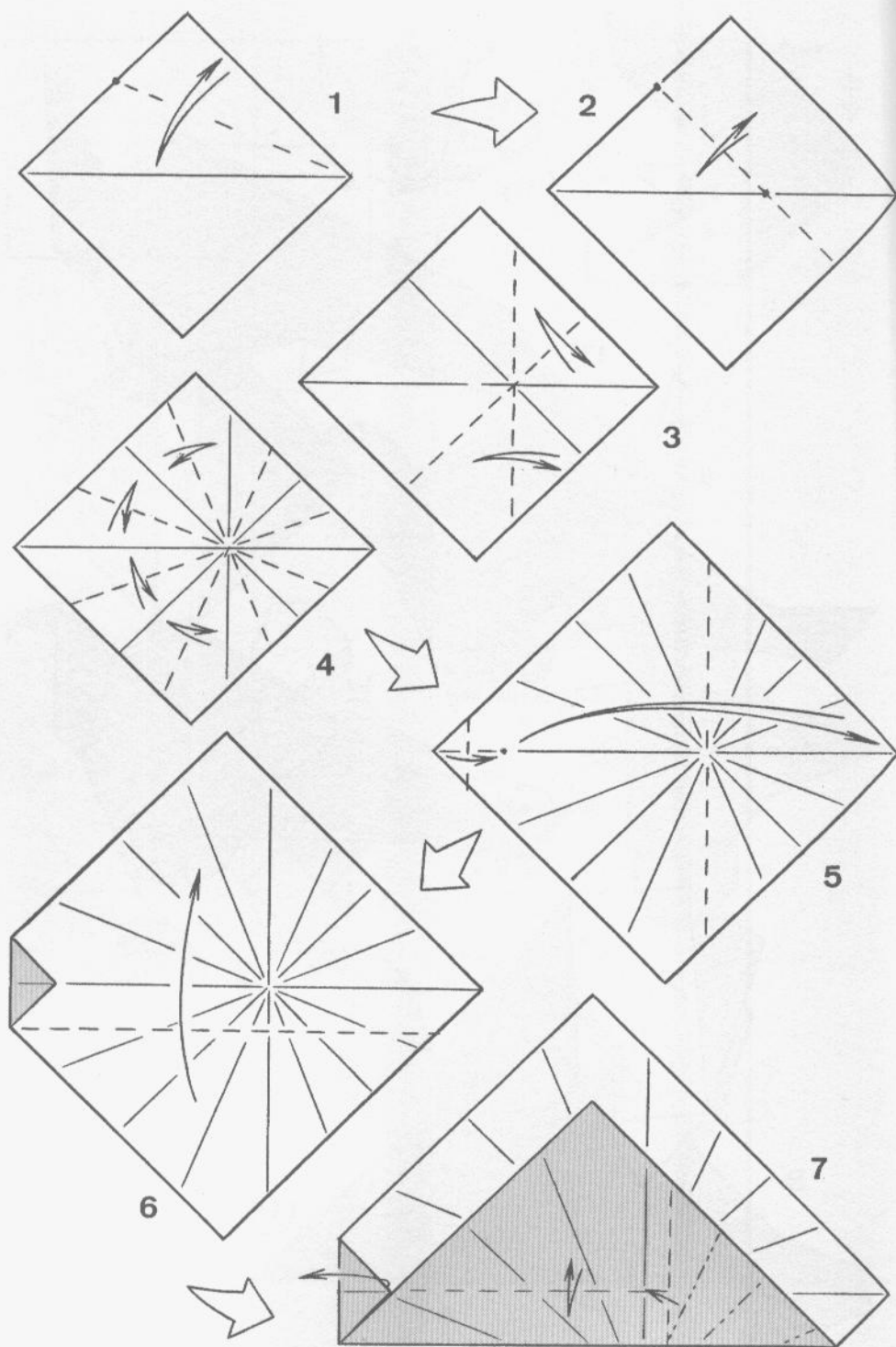

At each step we discover the next point of the silhouette of the shell!

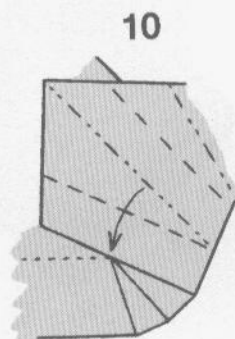
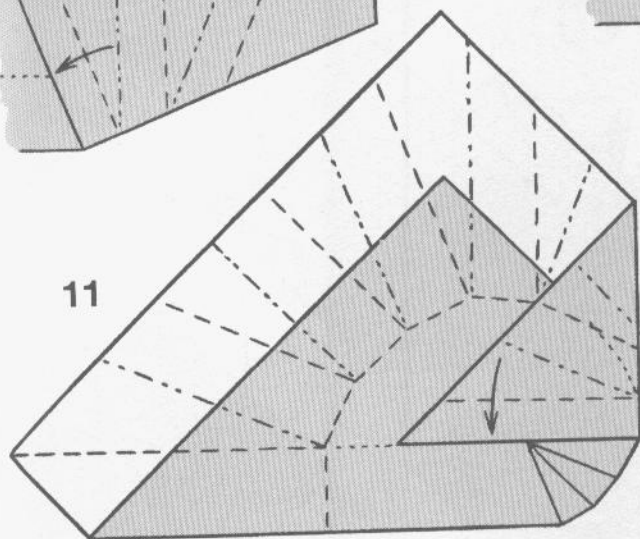
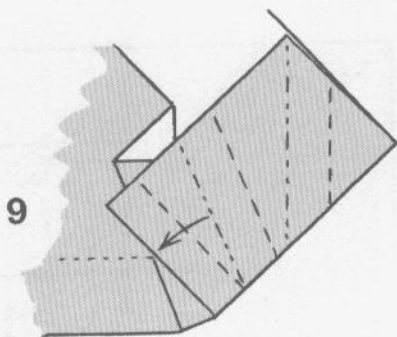
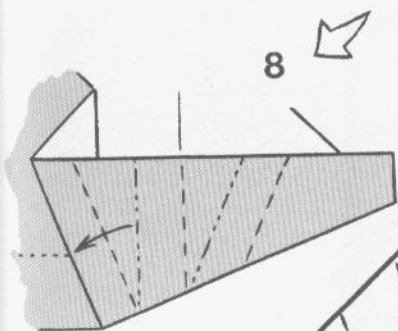

In figures 8 to 11, I indicate not only the creases that are in the paper, but also the folds that necessarily develop or that we are going to make.

This figure is, in its folding process, surprisingly original.

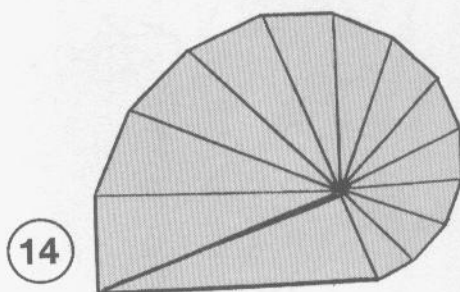
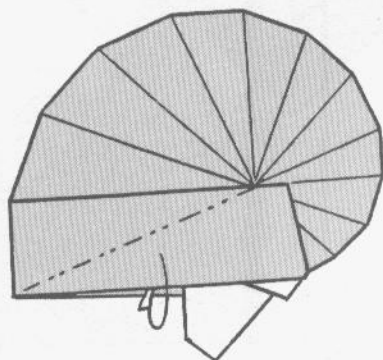
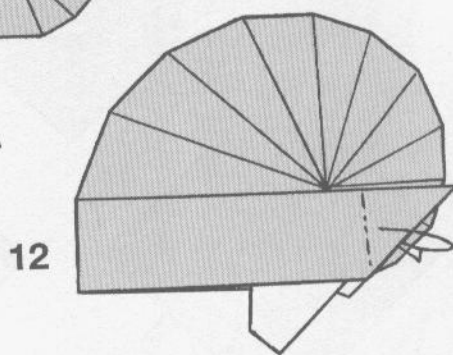

TROUGH WITH CRANES

by Alisa Afonkina

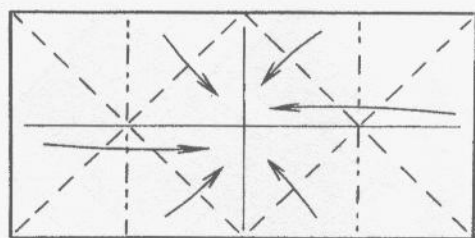

1

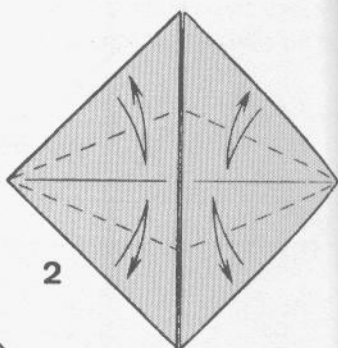

2

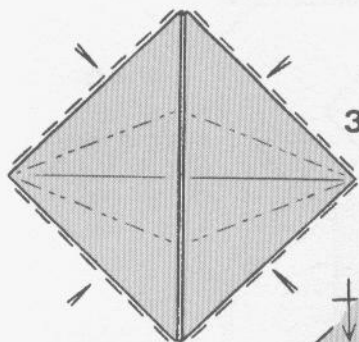

3

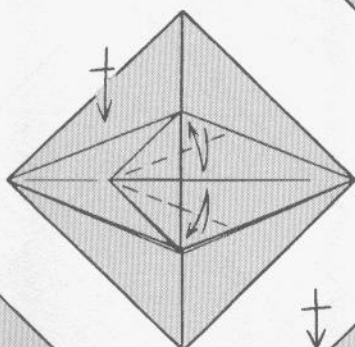

4

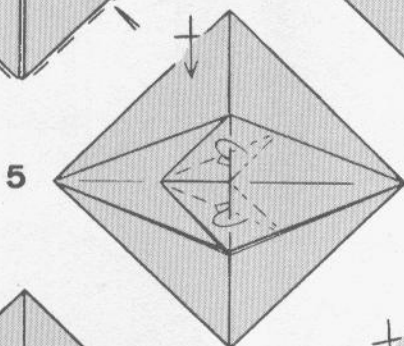

5

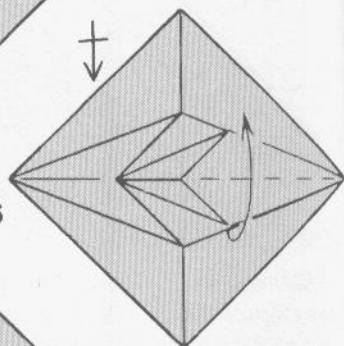

6

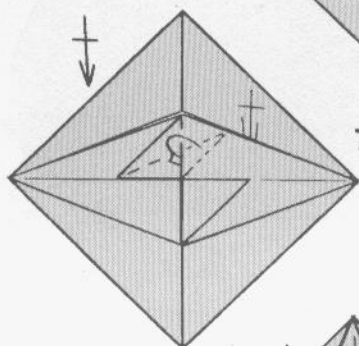

7

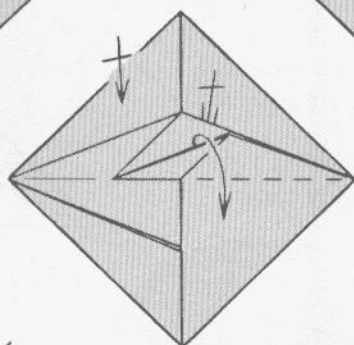

8

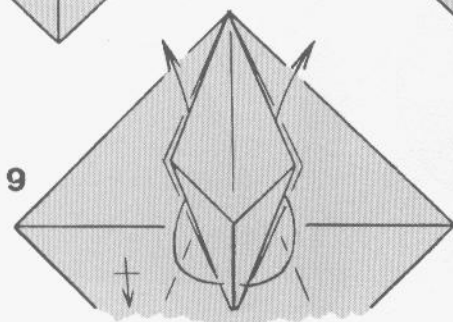

9

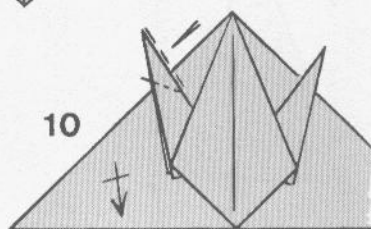

10

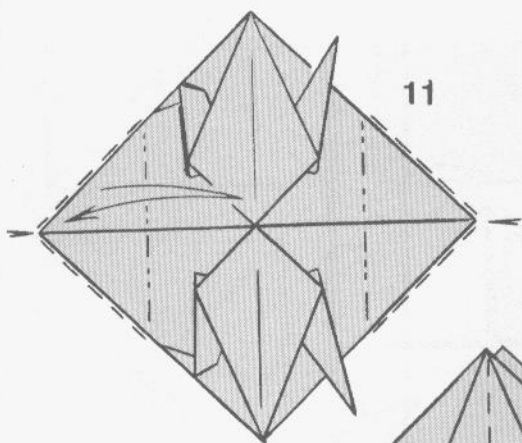

11

12

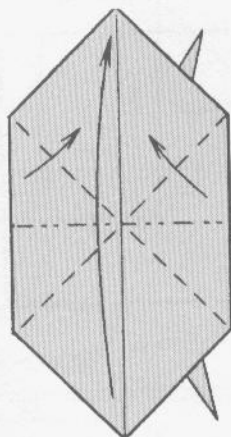

13

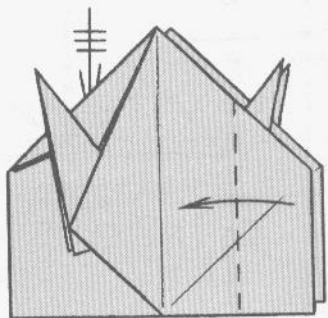
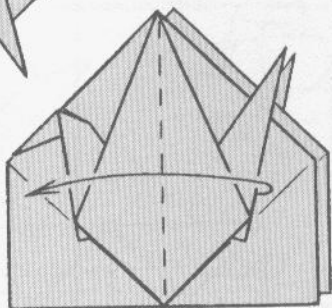

14

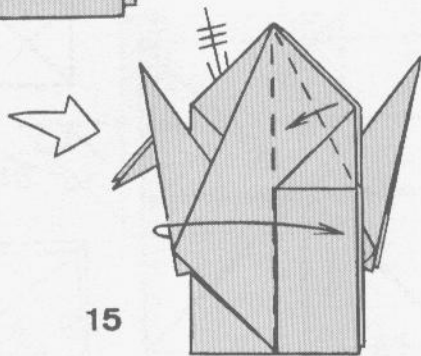

15

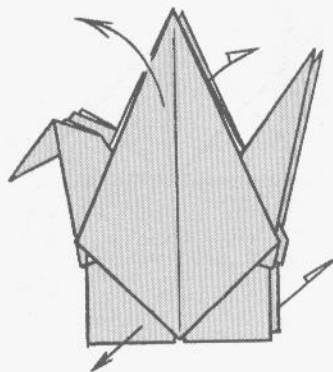

16

17

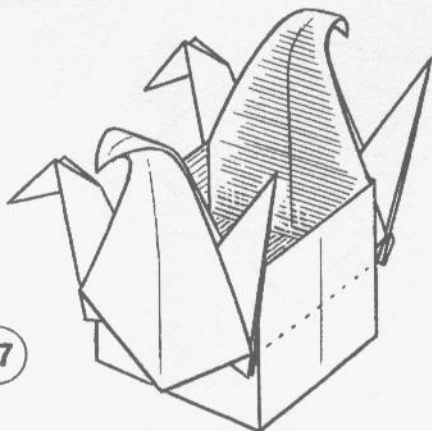

TWO-SEAT BOAT

Traditional

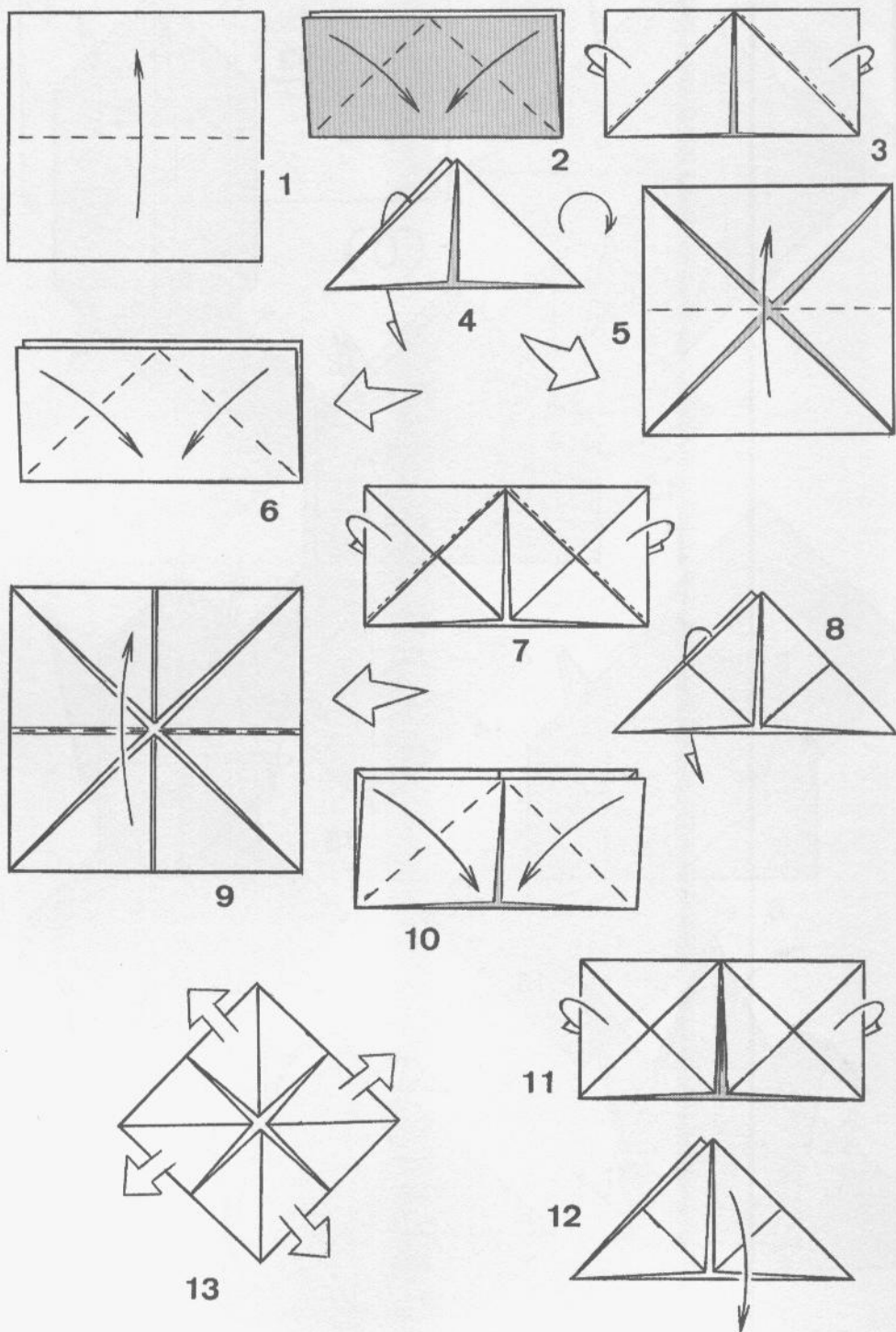

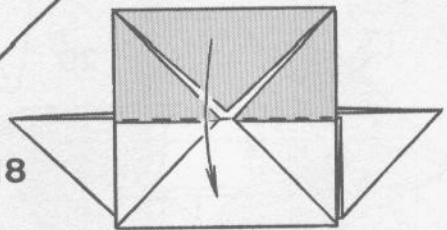
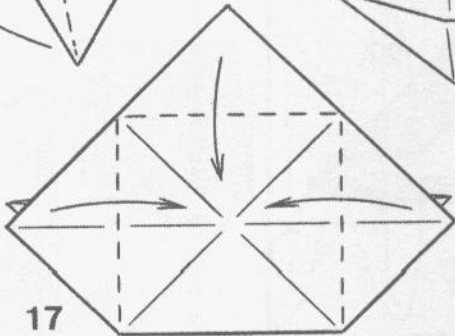
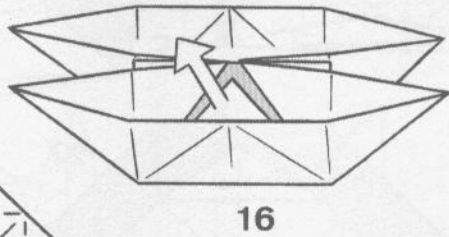
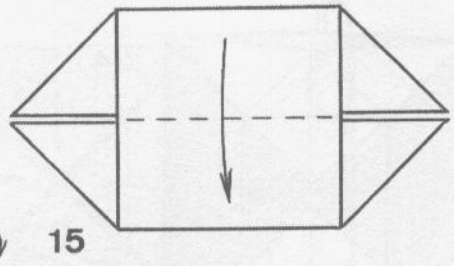
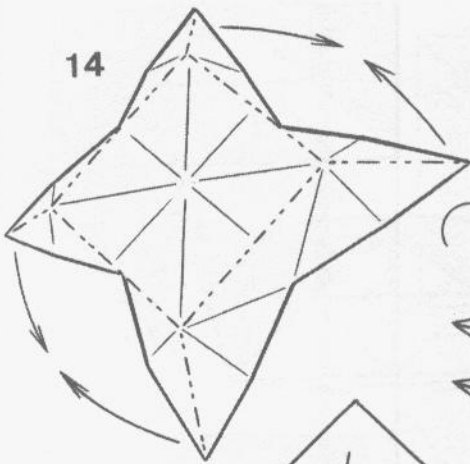

Repeat steps 16, 17, and 18 for the other little boat.

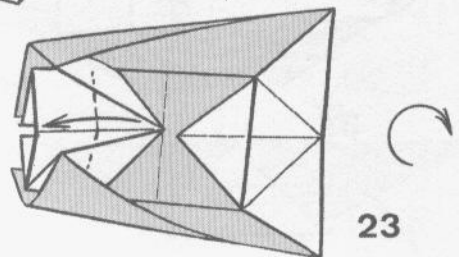
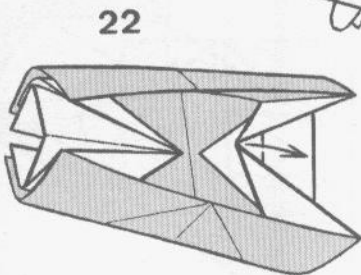
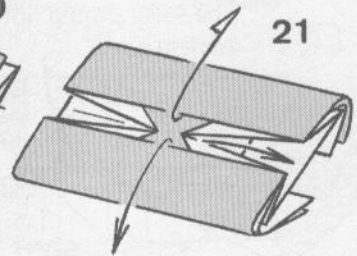
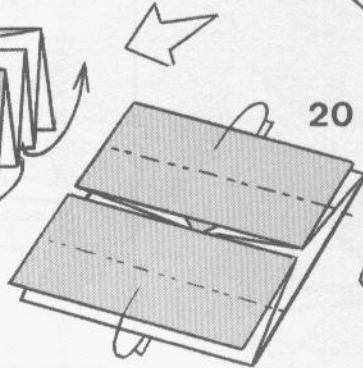
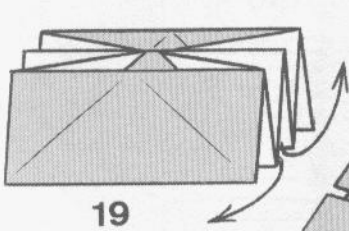

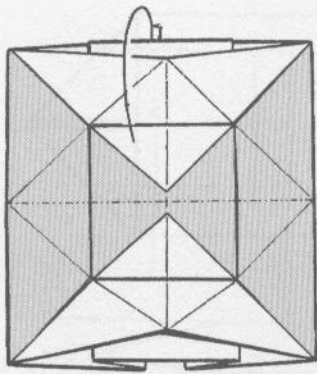

24

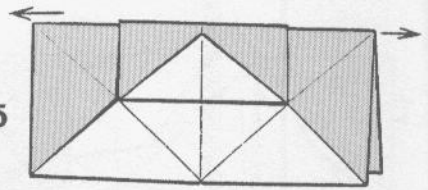

25

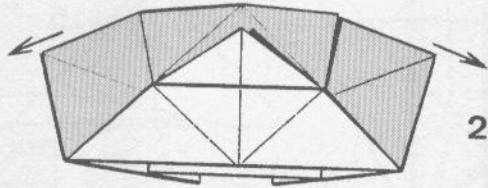

26

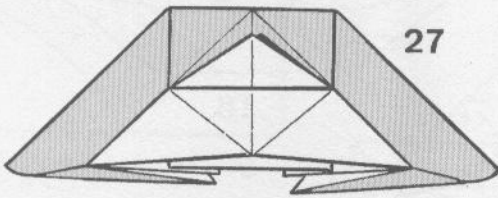

27

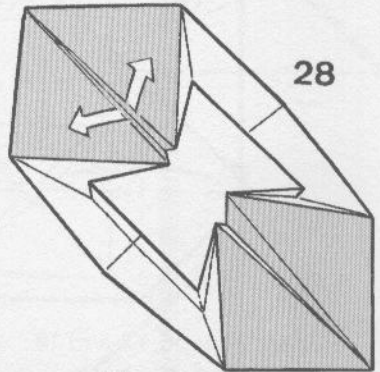

28

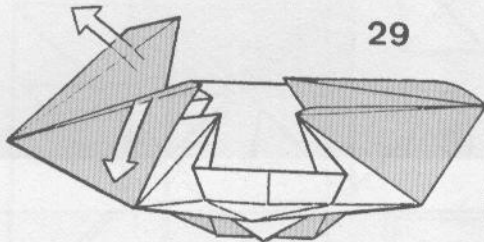

29

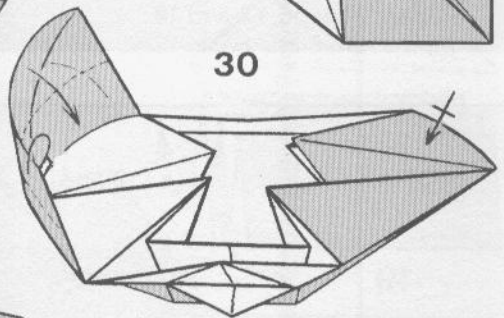

30

The seats should not remain open.

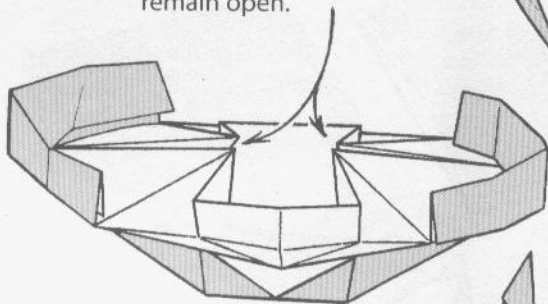

31

32

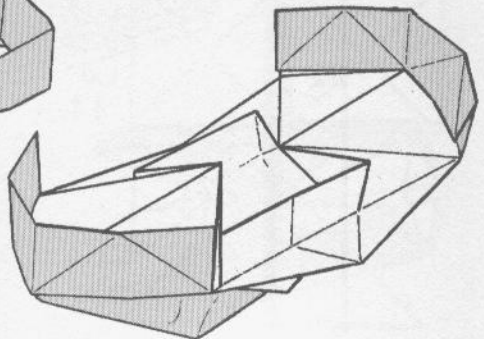

CHINESE JUNK

Traditional in Japan

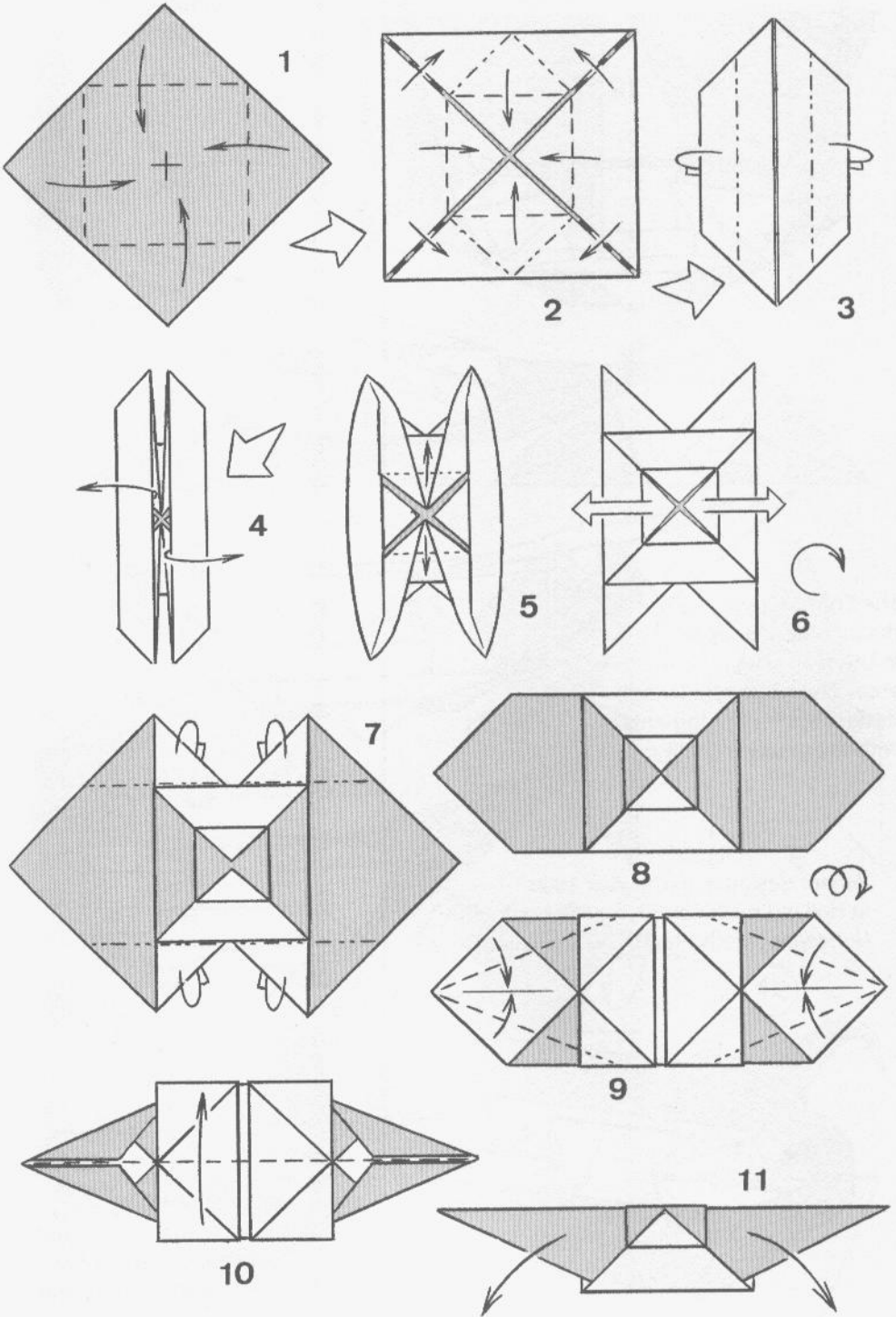

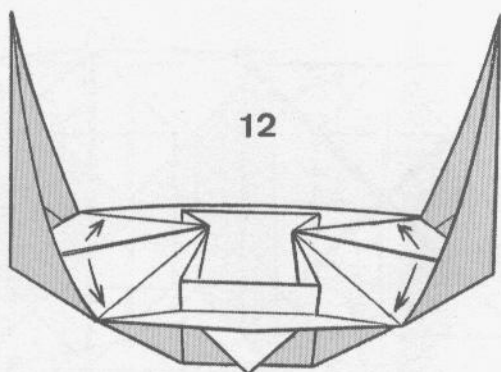

12

The Chinese Junk, as it is folded traditionally in Japan.

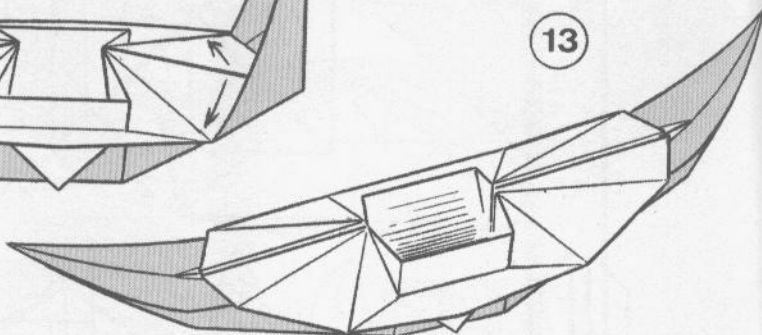

13

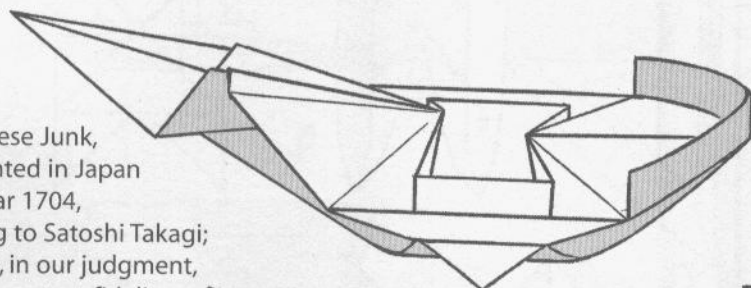

A

The Chinese Junk, documented in Japan in the year 1704, according to Satoshi Takagi; designed, in our judgment, with the greatest fidelity.

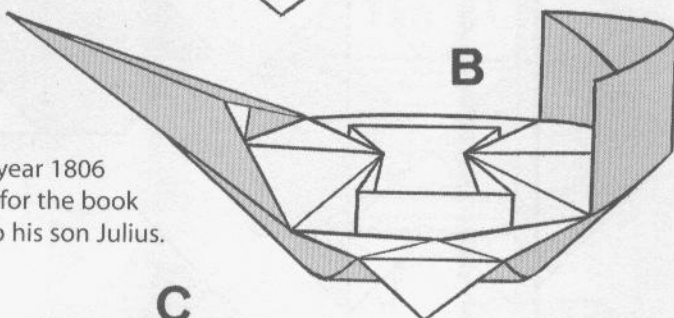

B

Variant designed in the year 1806 in Holland by Bilderdijk, for the book *Hanenpoot*, dedicated to his son Julius.

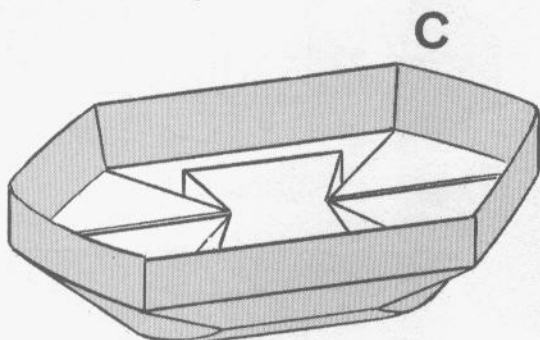

C

The closed two-seat boat in a modern version. This variant was invented by D. Gabriel Álvarez, but it already was known previously.

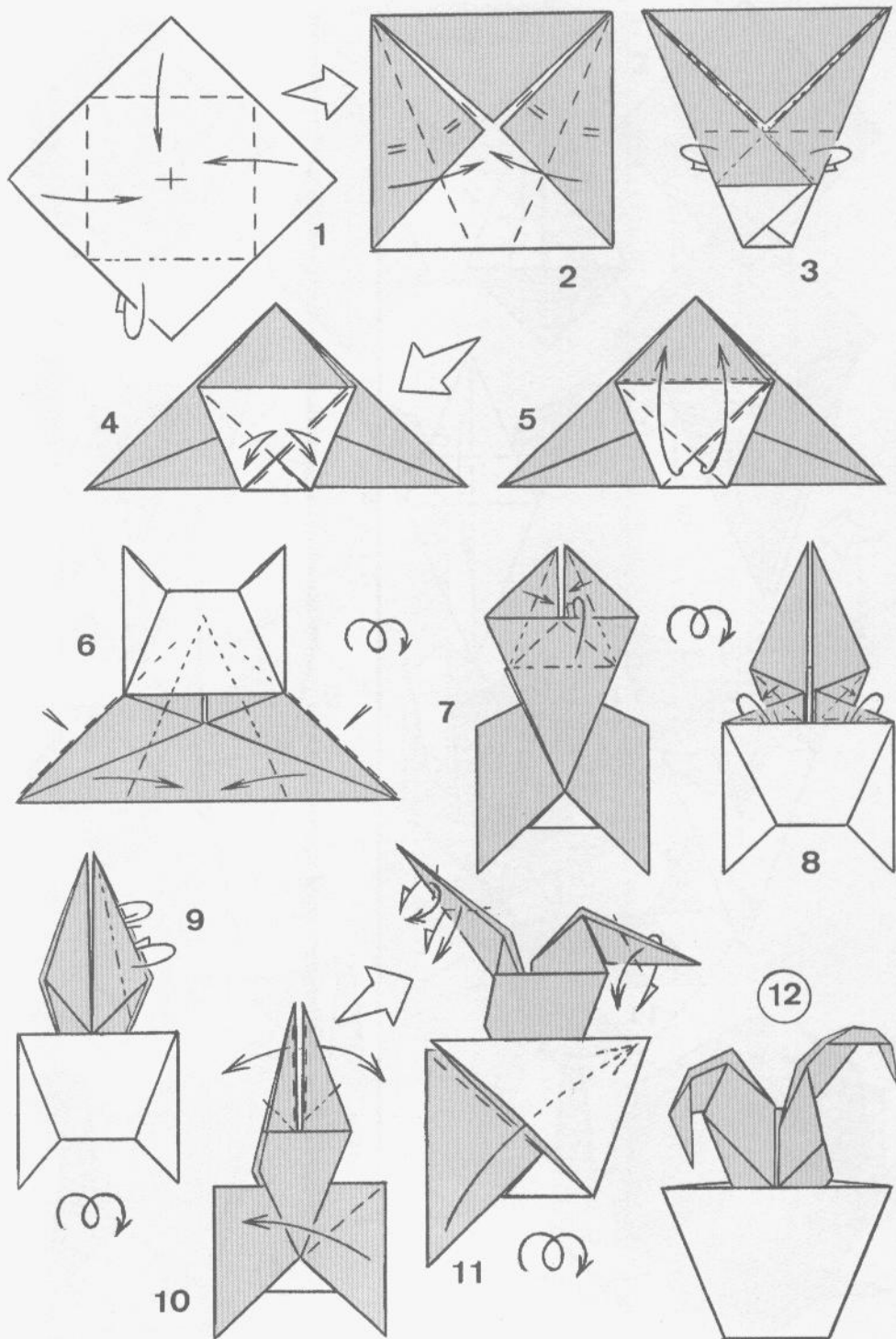

LOHENGRIN'S SWAN

by Dr. V. Solórzano

Repeat steps 1, 2, and 3
for the lower half.

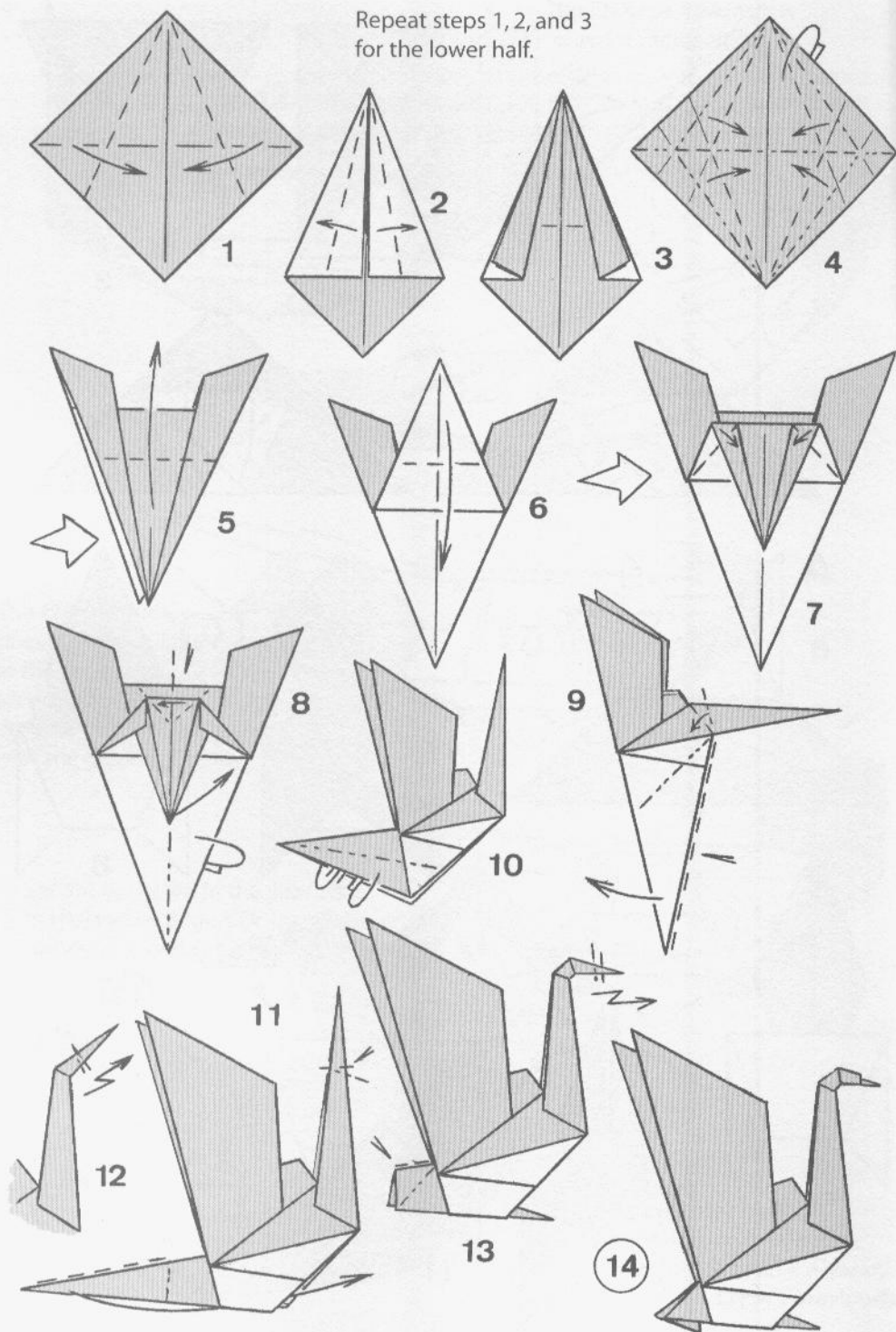

TRUNCATED CUBE

by Francisco Javier Capoblanco

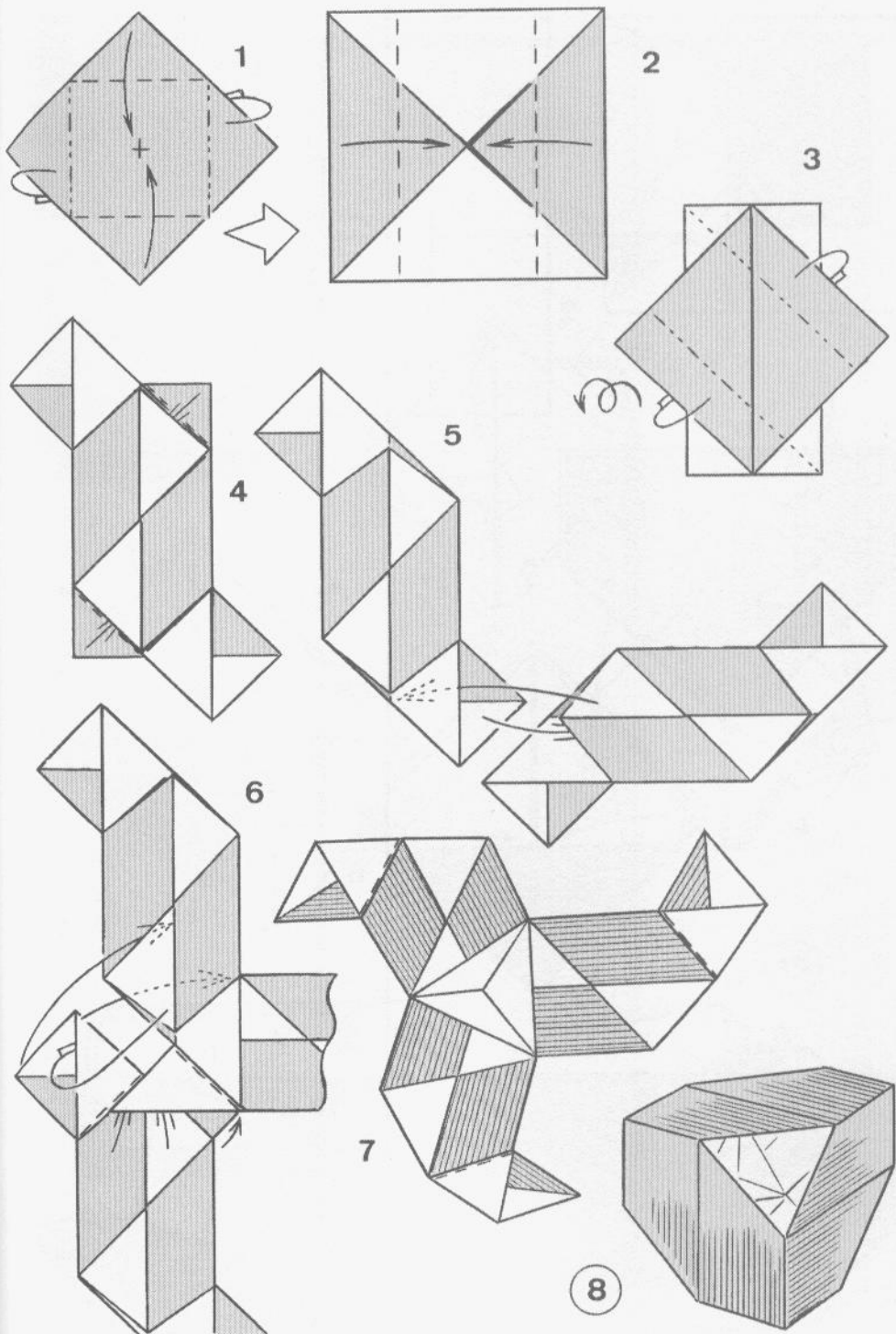

BOX WITH HANDLES

by Dr. Philip Shen

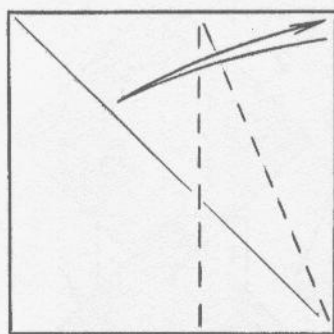

1



2

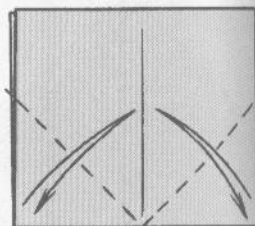
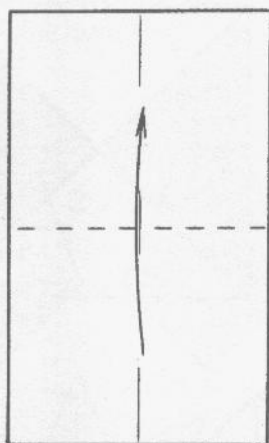

3

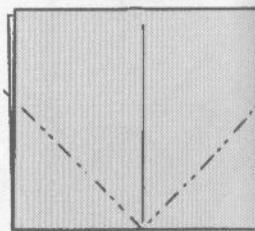

4

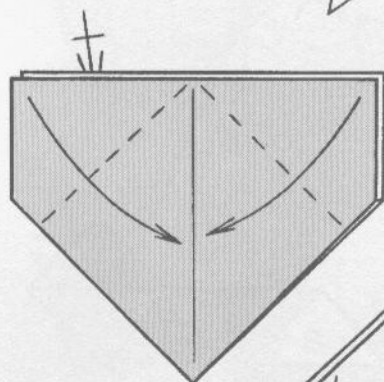

5

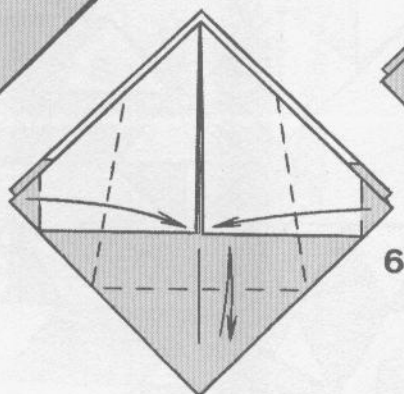

6

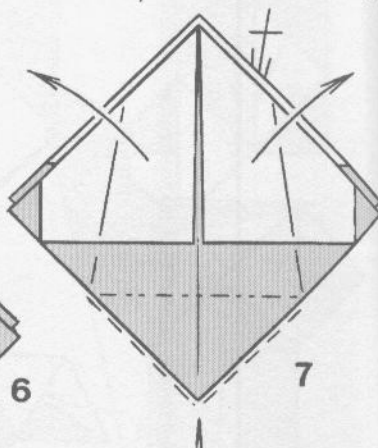

7

8

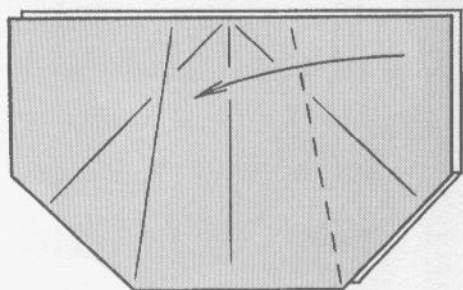

9

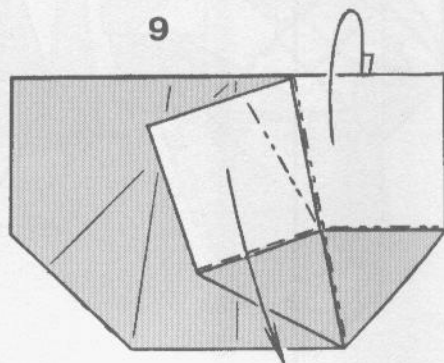

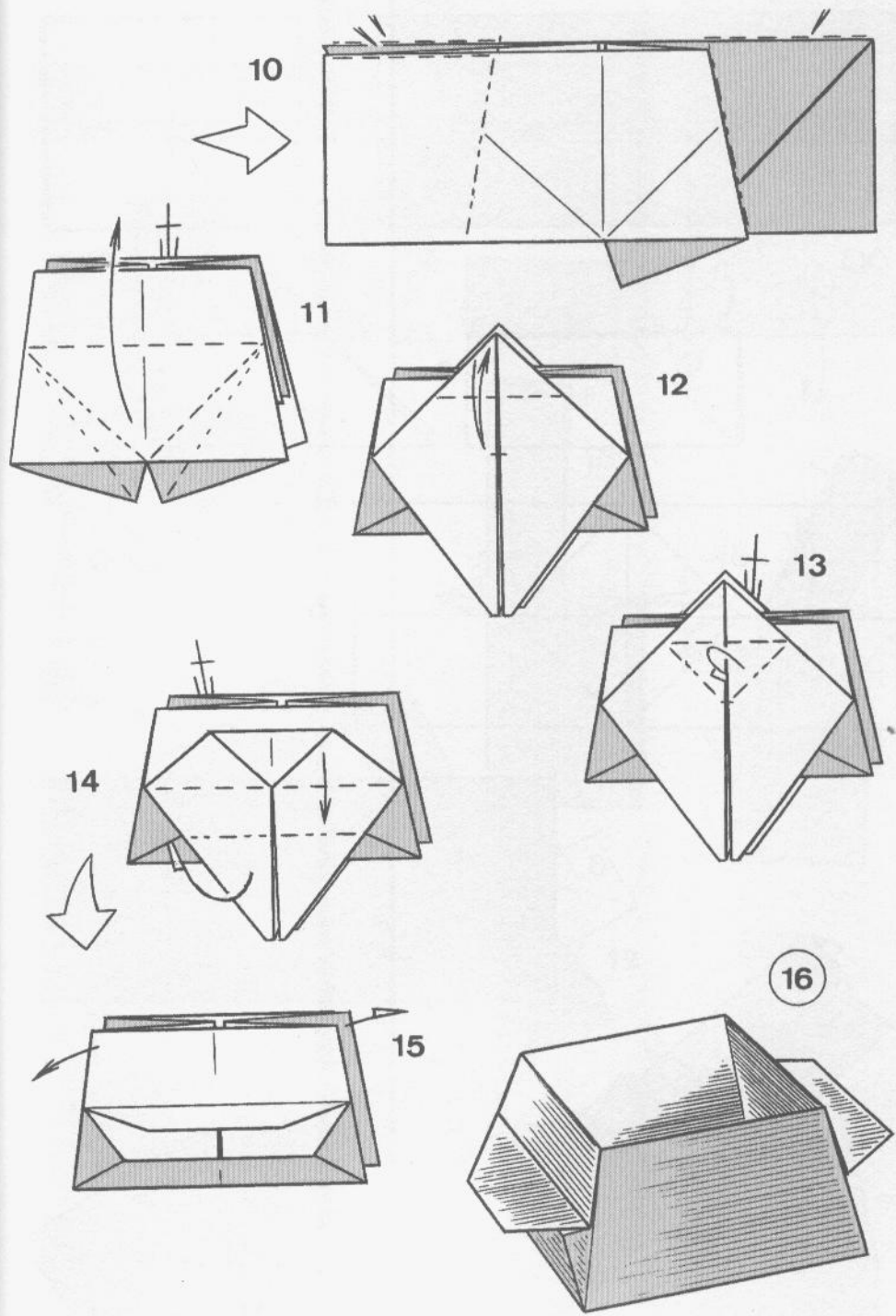

YOUNG DUTCHWOMAN ("billfold")

by Fred Rohm

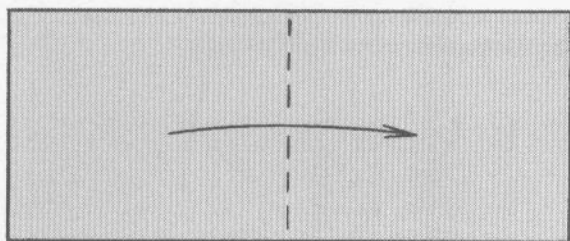

7x3

1

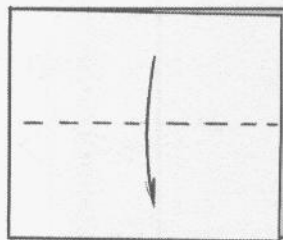

2

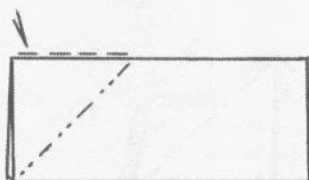

3

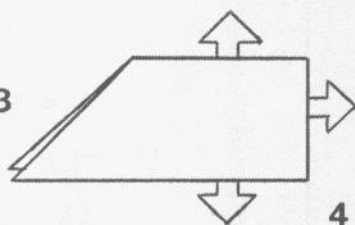

4

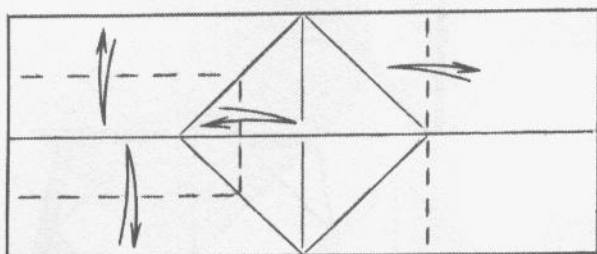

5

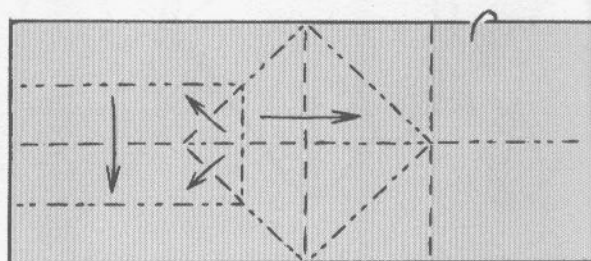

6

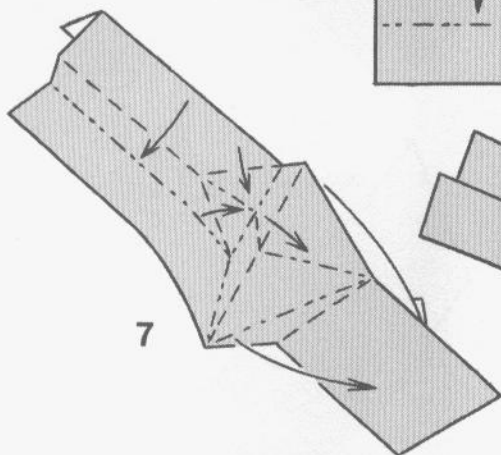

7

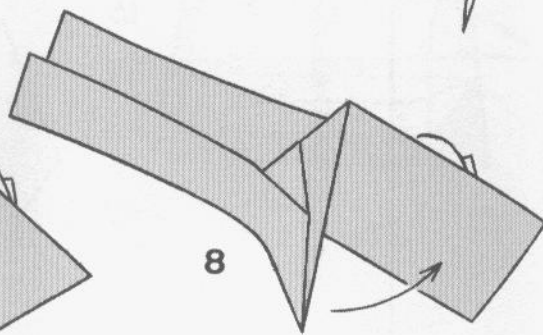

8

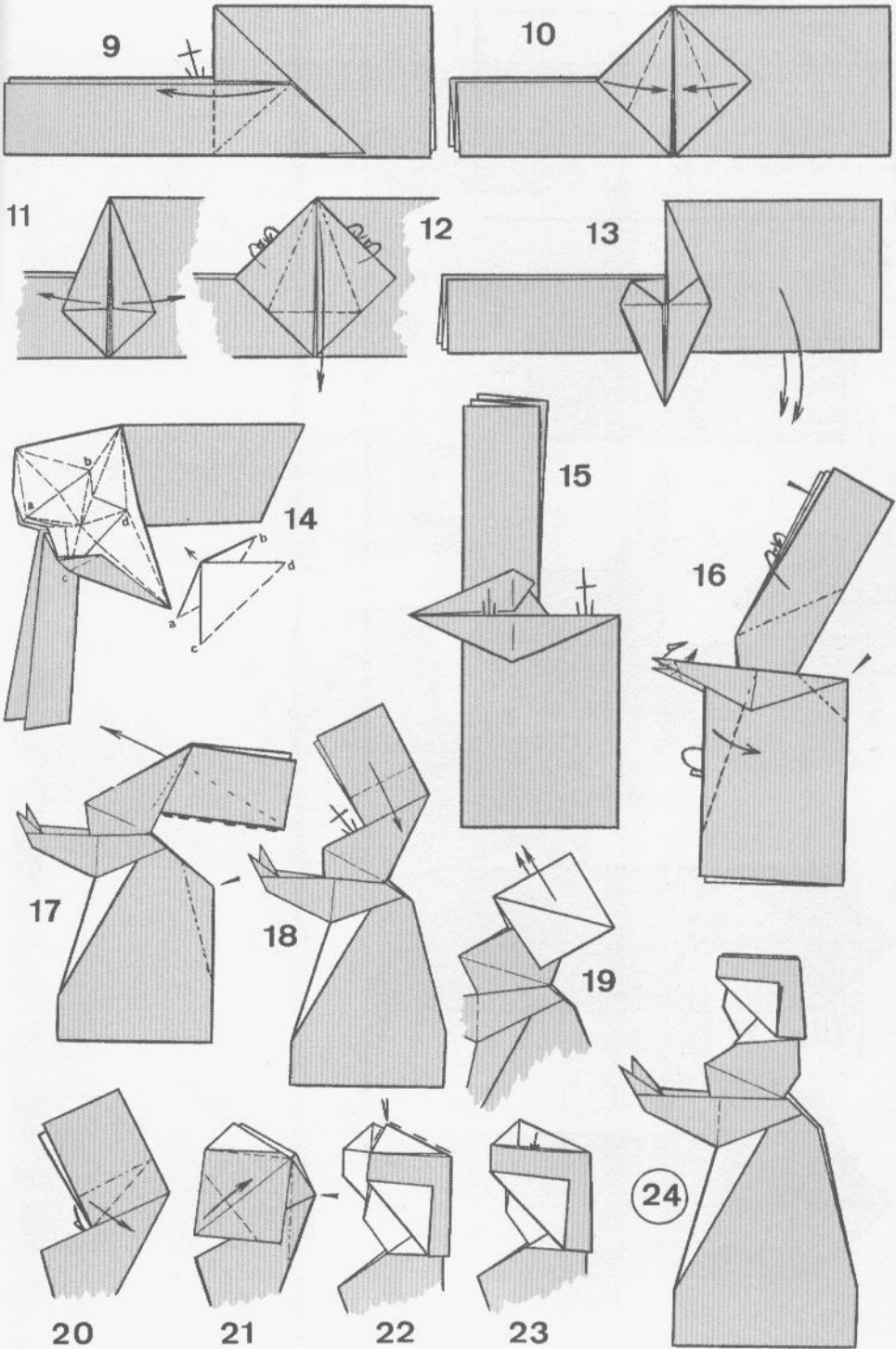

RABBIT

by Yoshihide Momotani

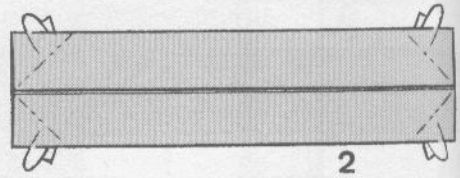
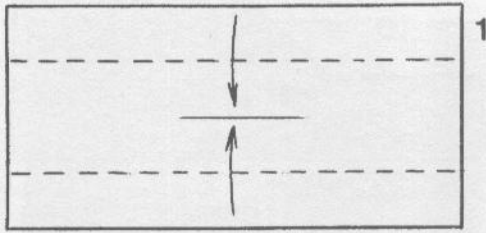

2x1

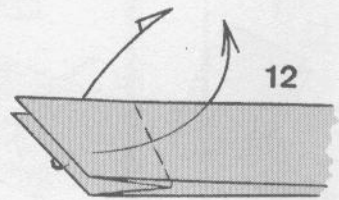
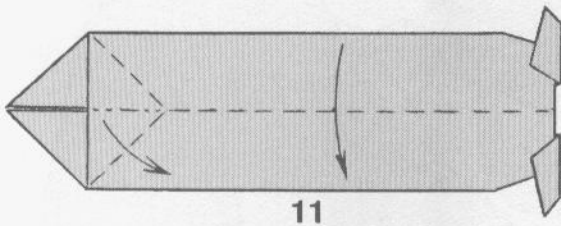
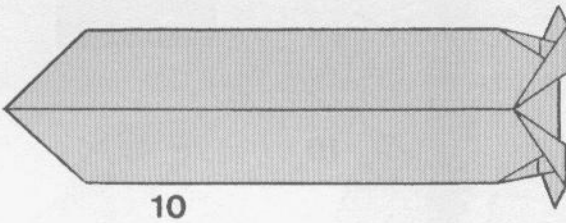
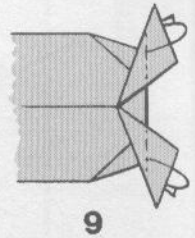
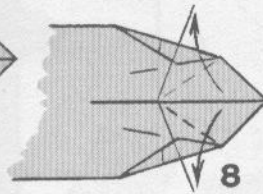
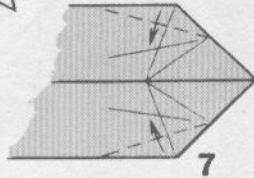
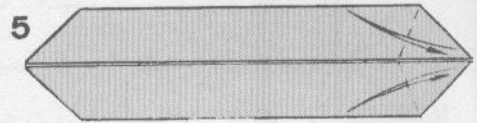
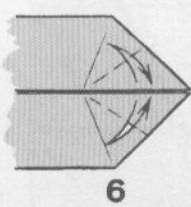
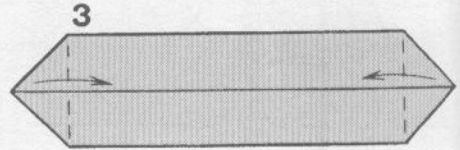
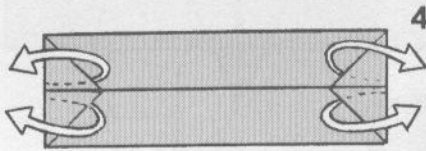

With 12-x-6-inch paper a 2.4-x-3.6-inch rabbit is obtained.

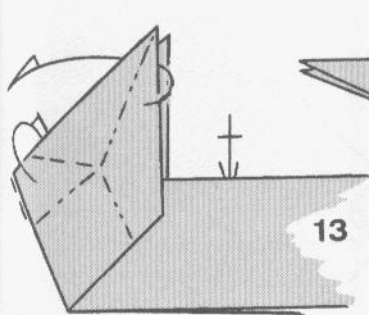

13

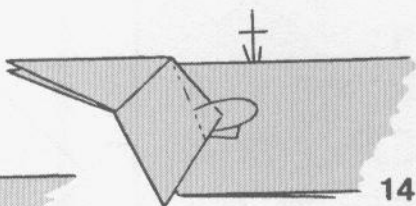

14

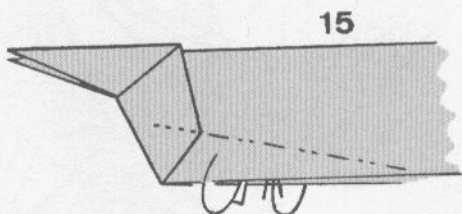

15

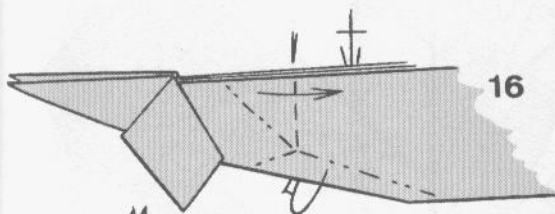

16

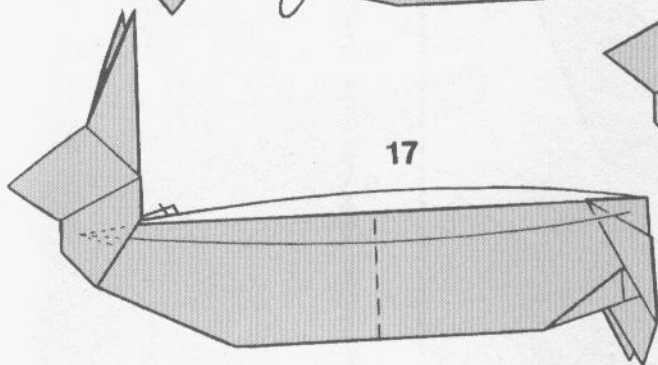

17

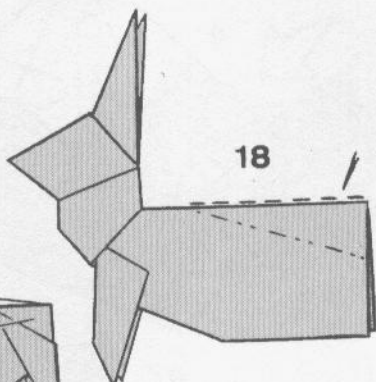

18

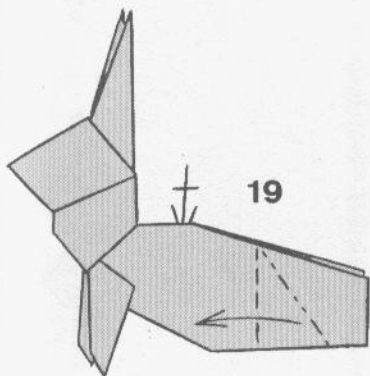

19

21

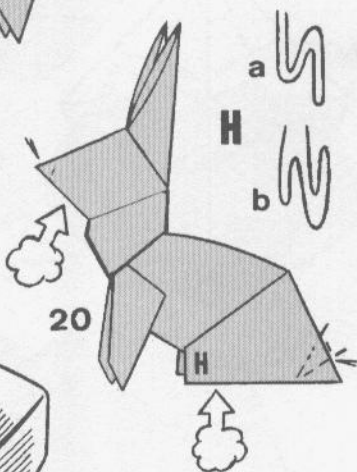

20

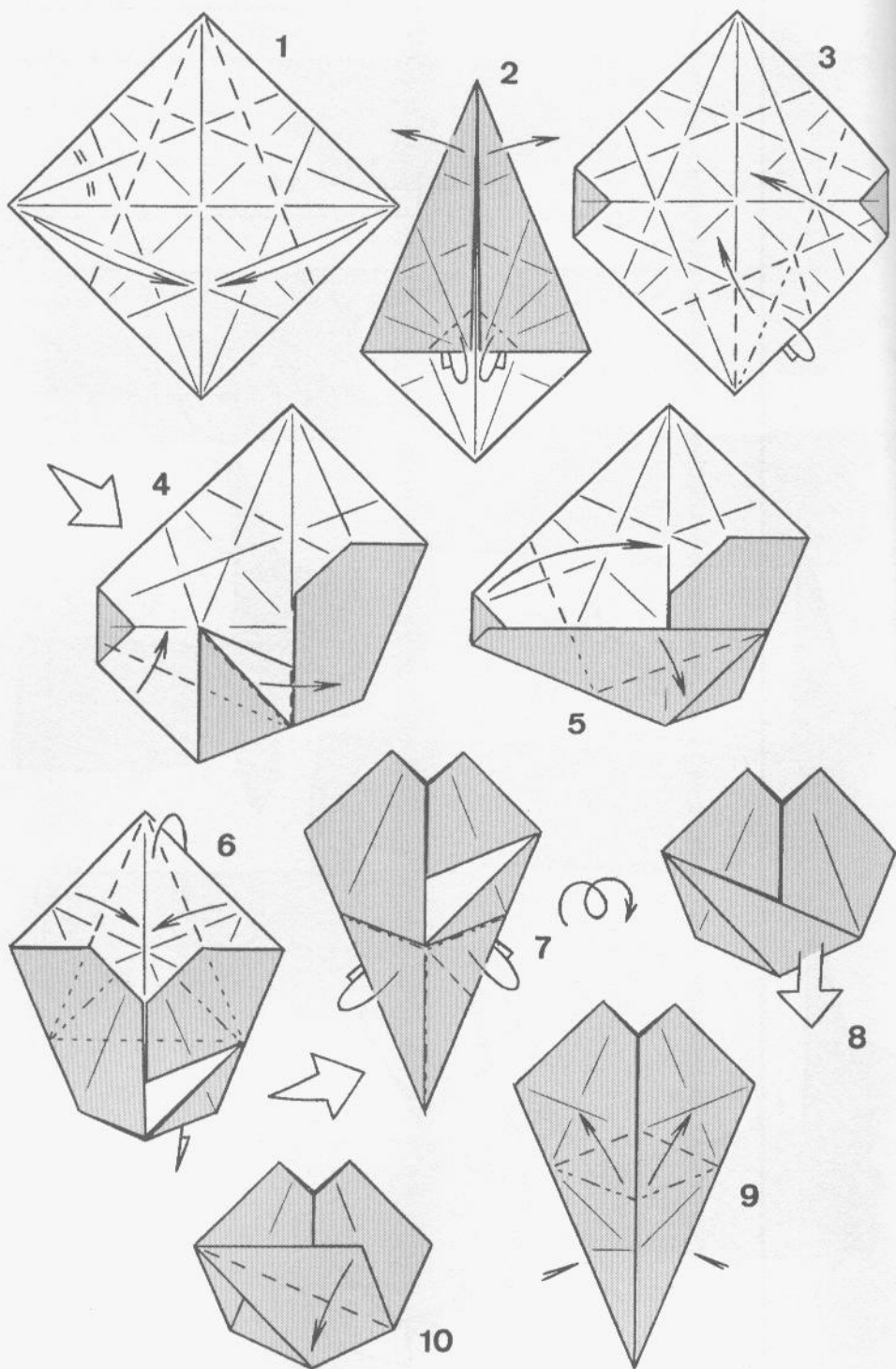

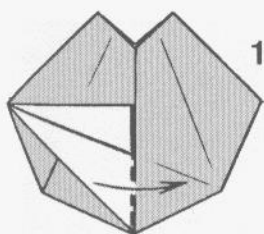

11

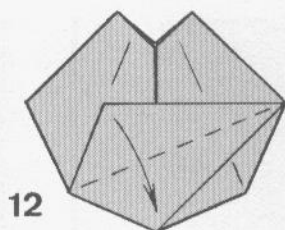

12

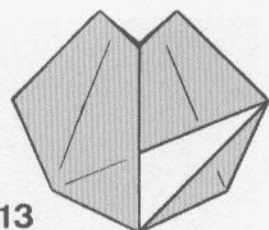

13

Make **8** equal modules and put them together this way:

MODULE

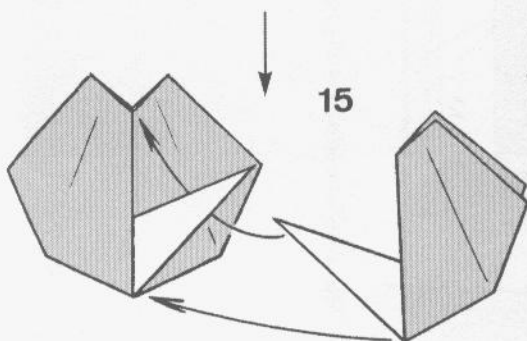

15

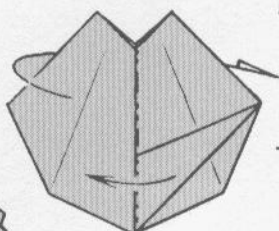

14

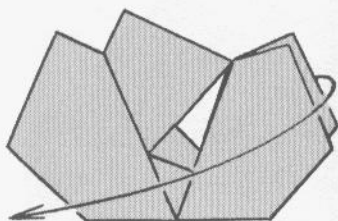

17

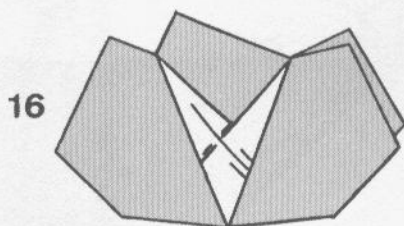

16

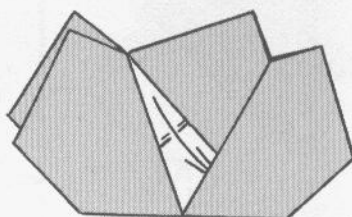

18

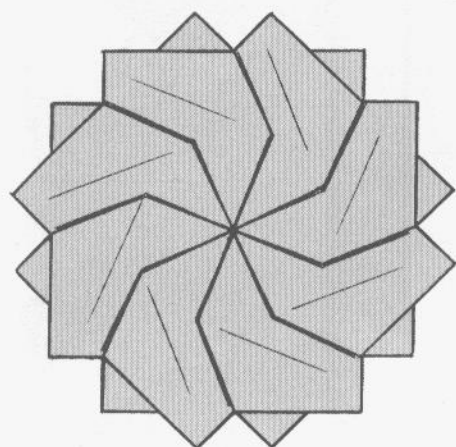

21

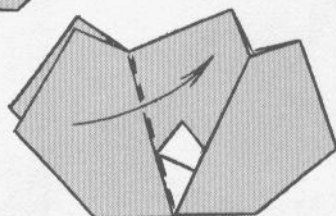

19

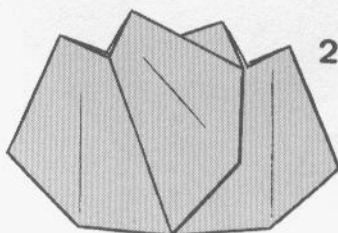

20

FISH THAT OPENS AND SHUTS ITS MOUTH by Genta Battistina

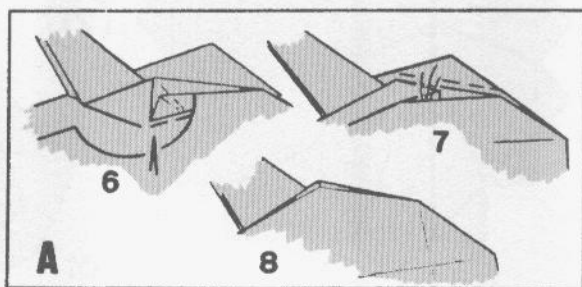
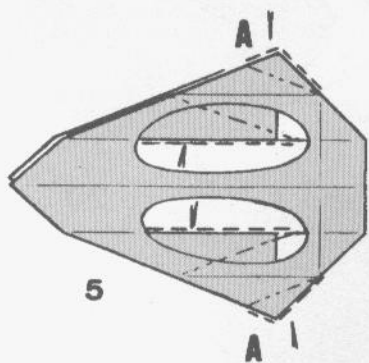
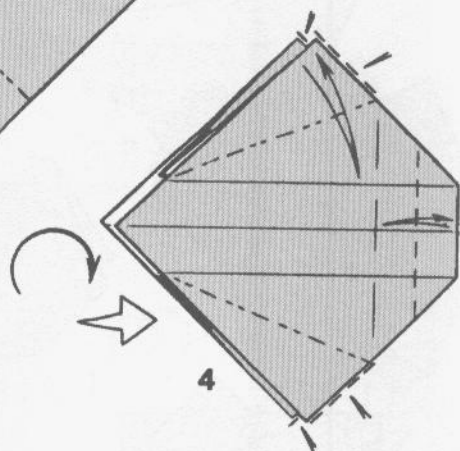
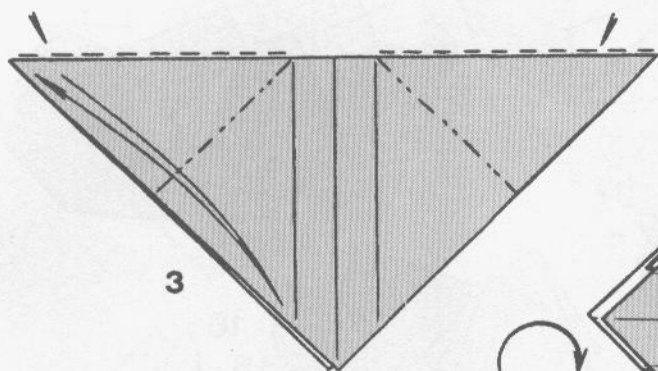
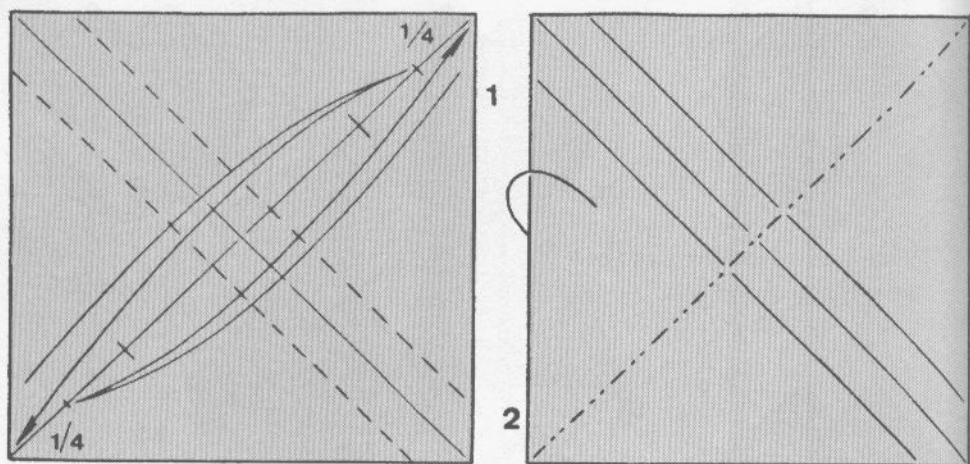

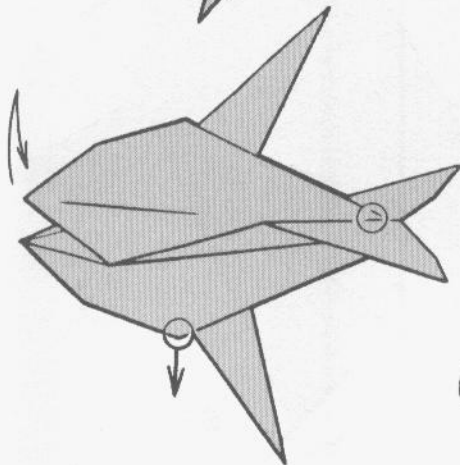
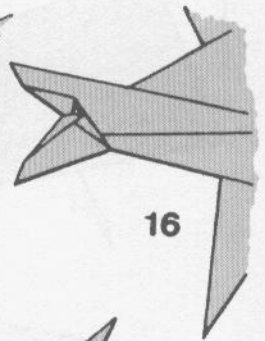
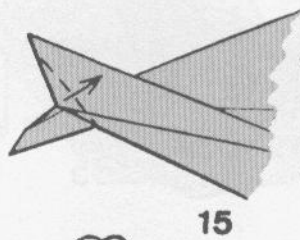
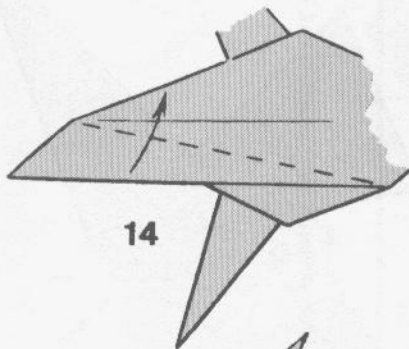
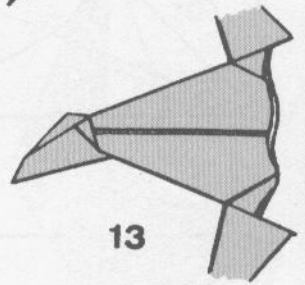
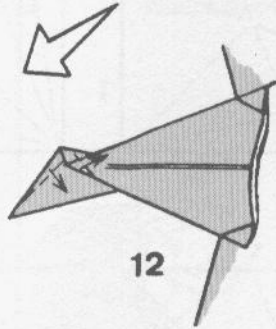
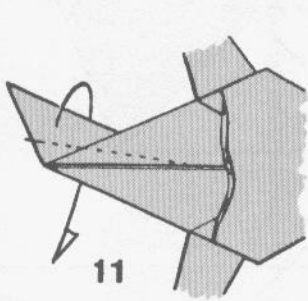
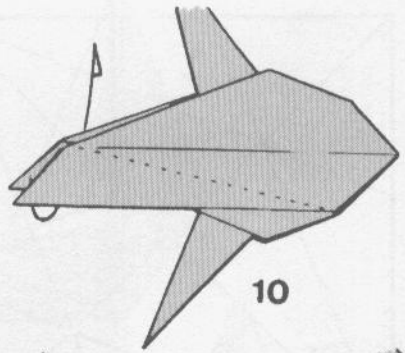
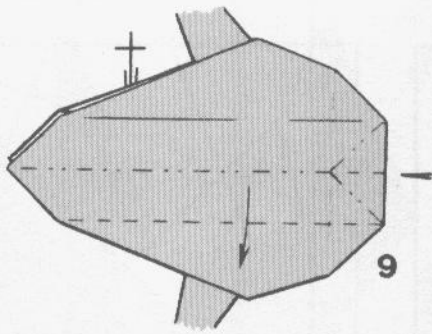

17

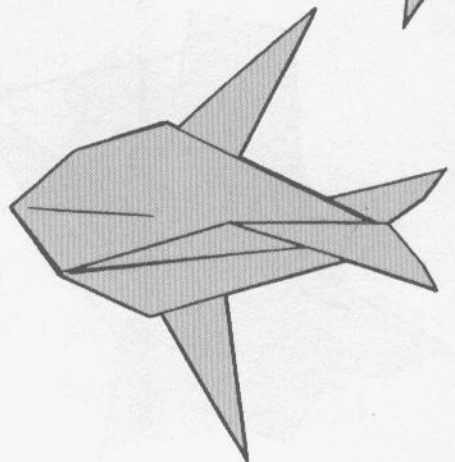

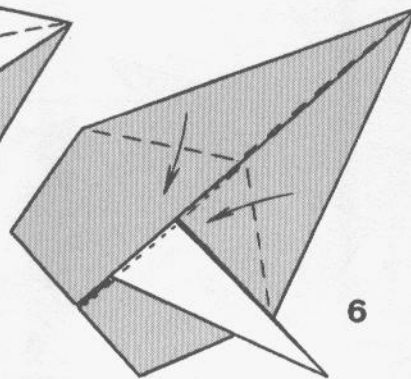
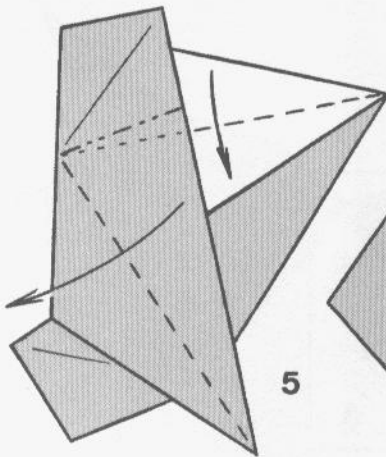
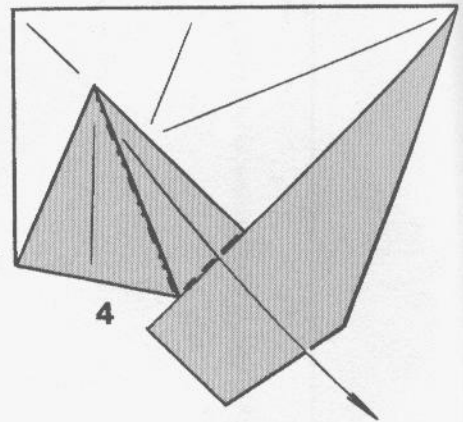
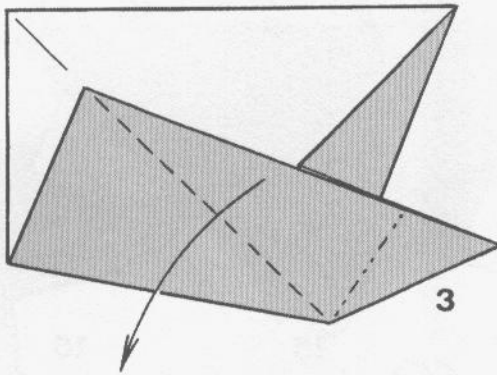
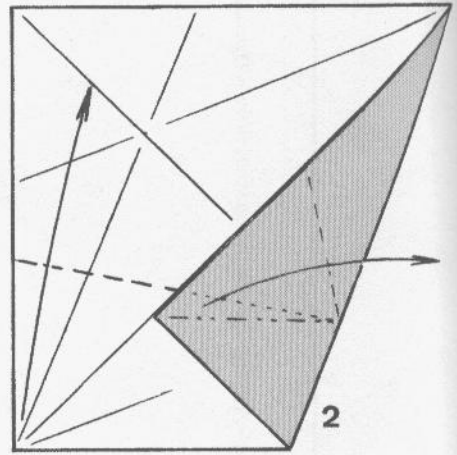
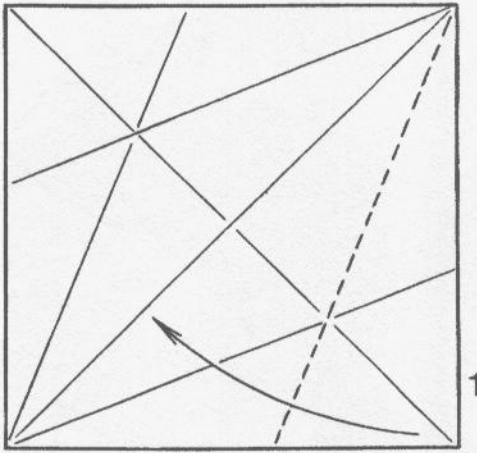

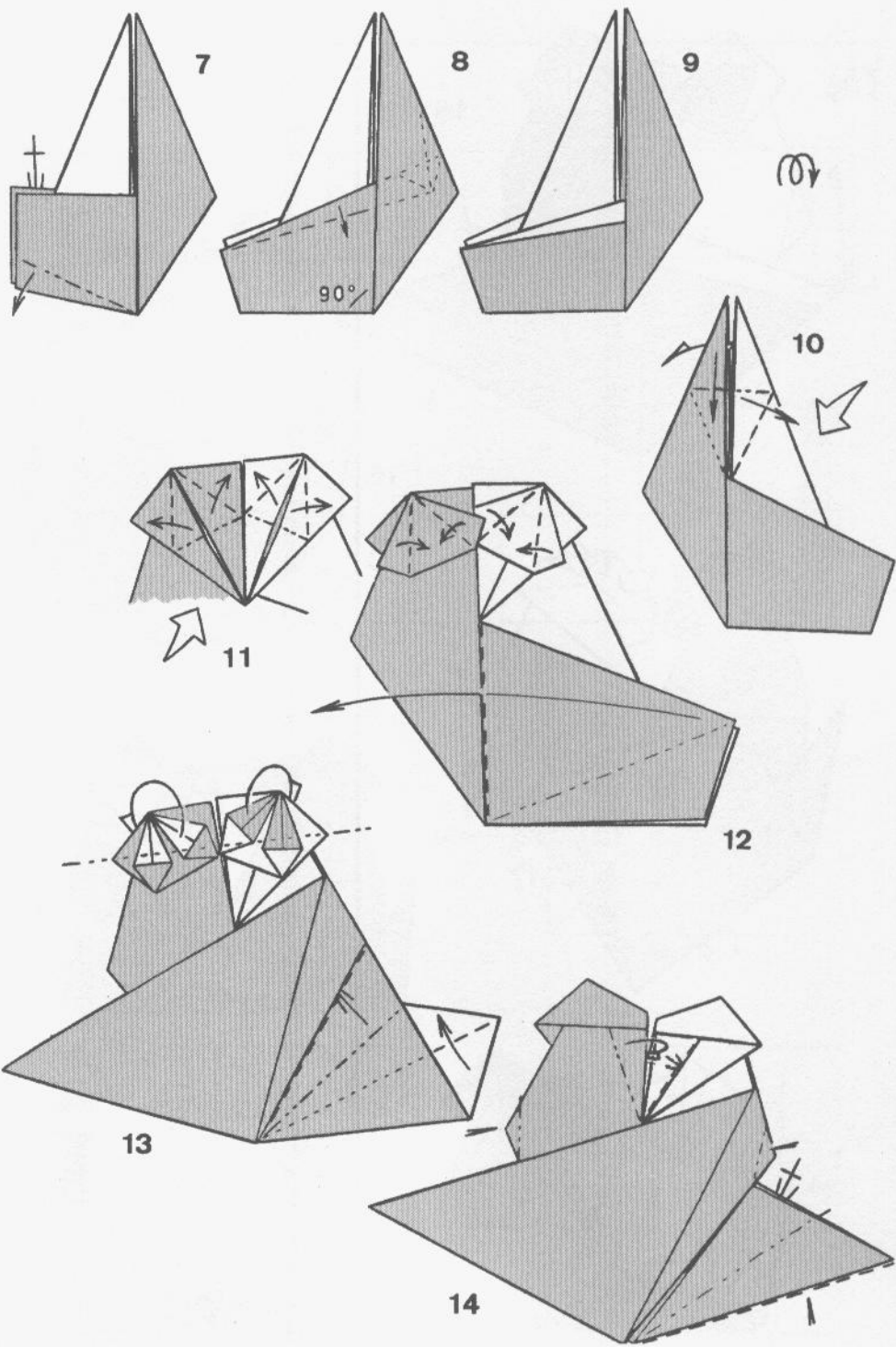

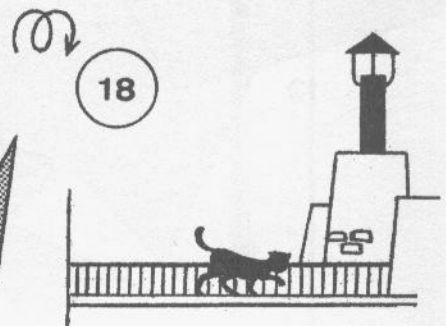
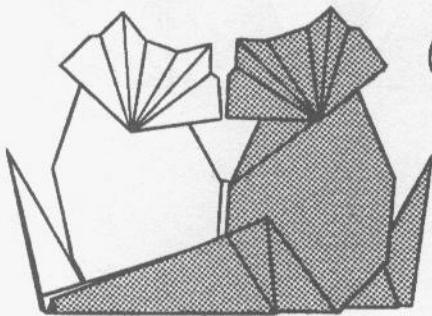
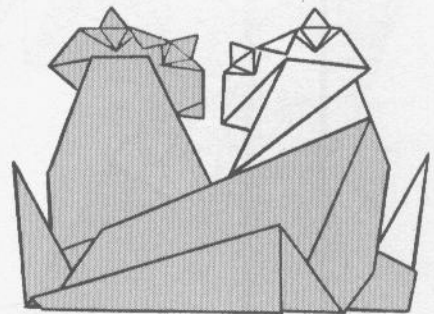
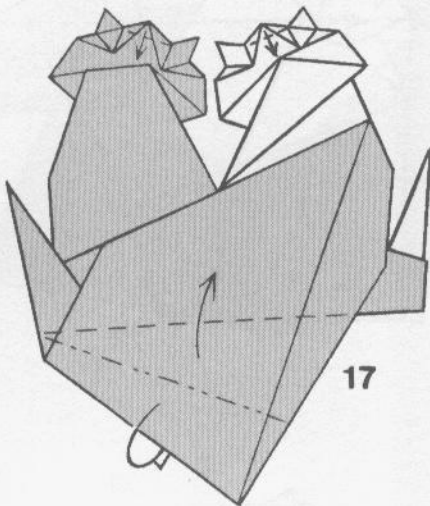
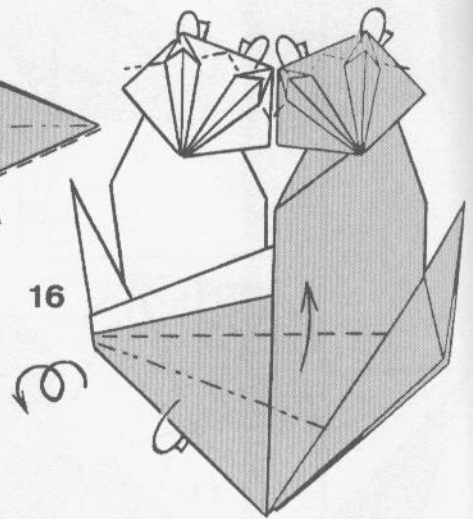
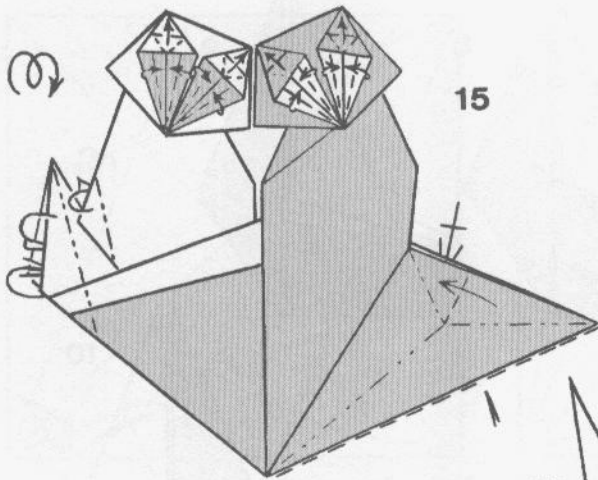

LITTLE BIRD IN BOAT

by Vicente Palacios

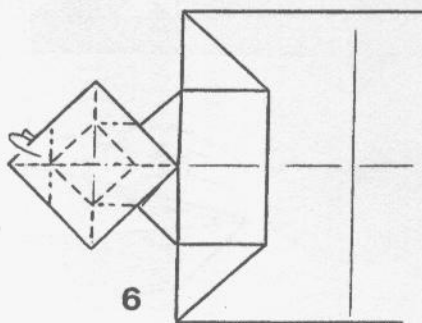
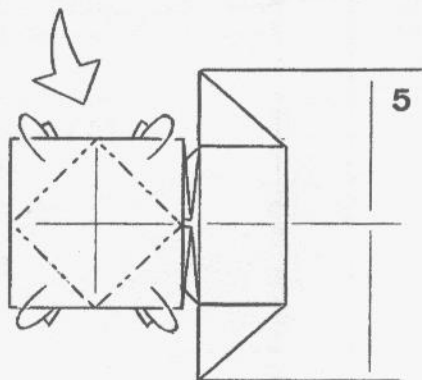
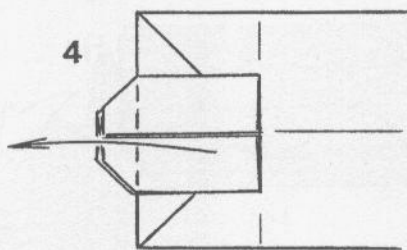
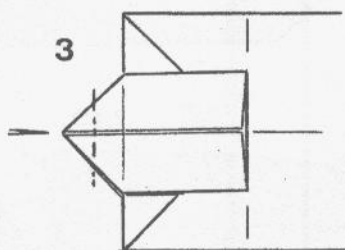
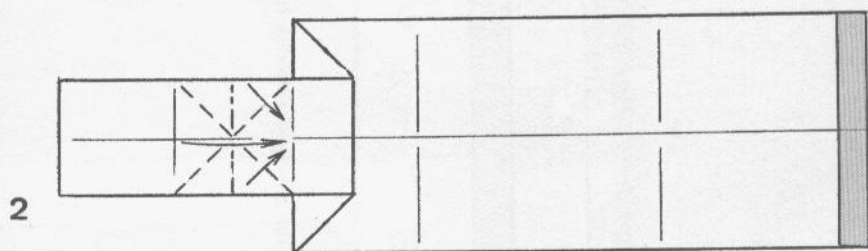
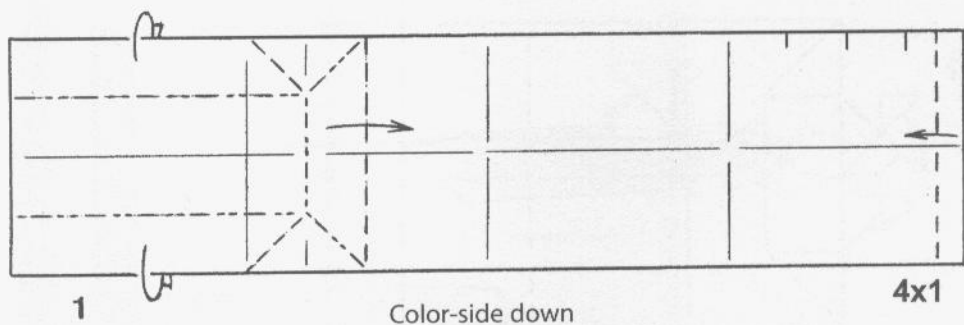

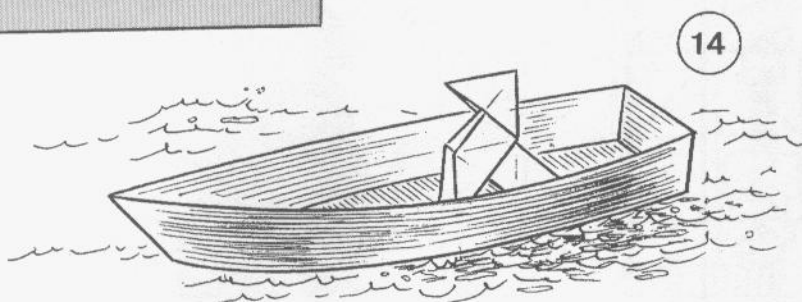
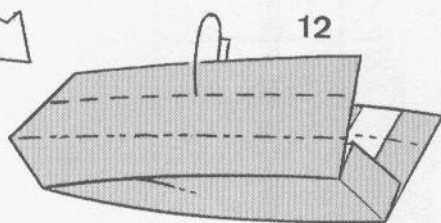
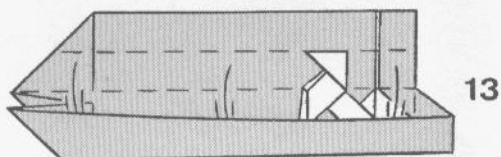
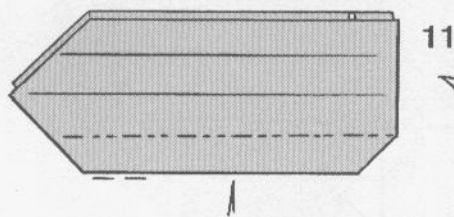
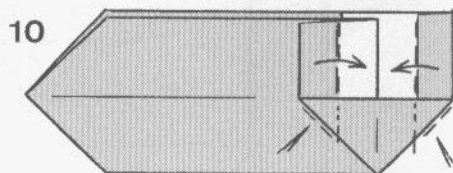
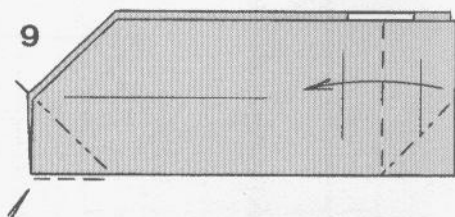
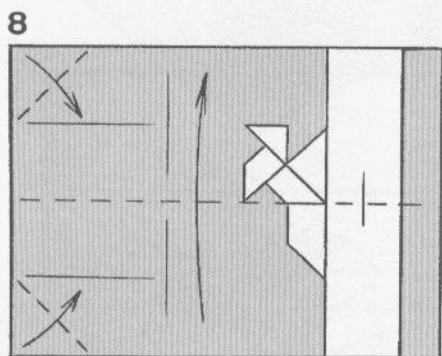
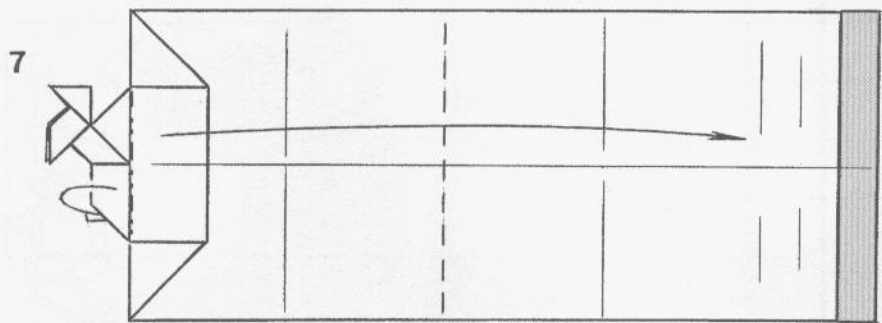

THREE VARIANTS BY THE SAME CREATOR

3 x 1 paper

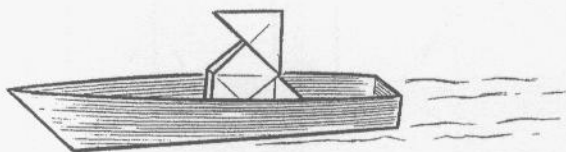

4 x 1 paper

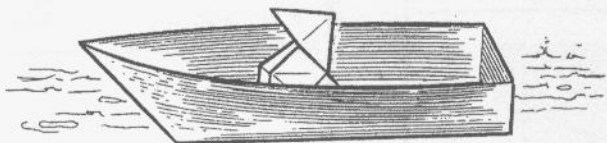

4 x 1 paper



DECORATED BOX (variant)

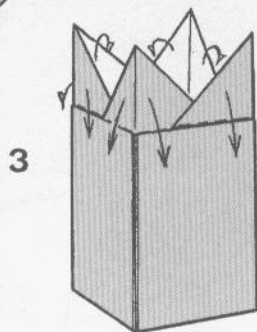
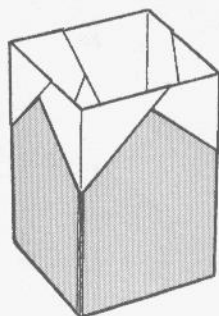
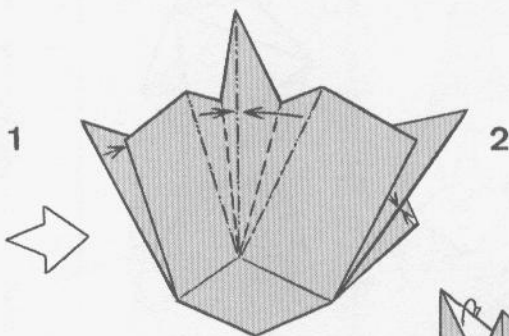
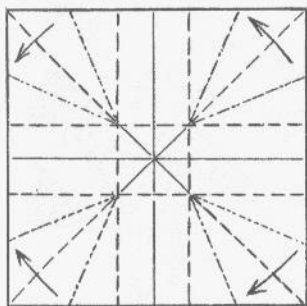

④

INTERLOCKED HEXAGONS

by Daniel Geriant

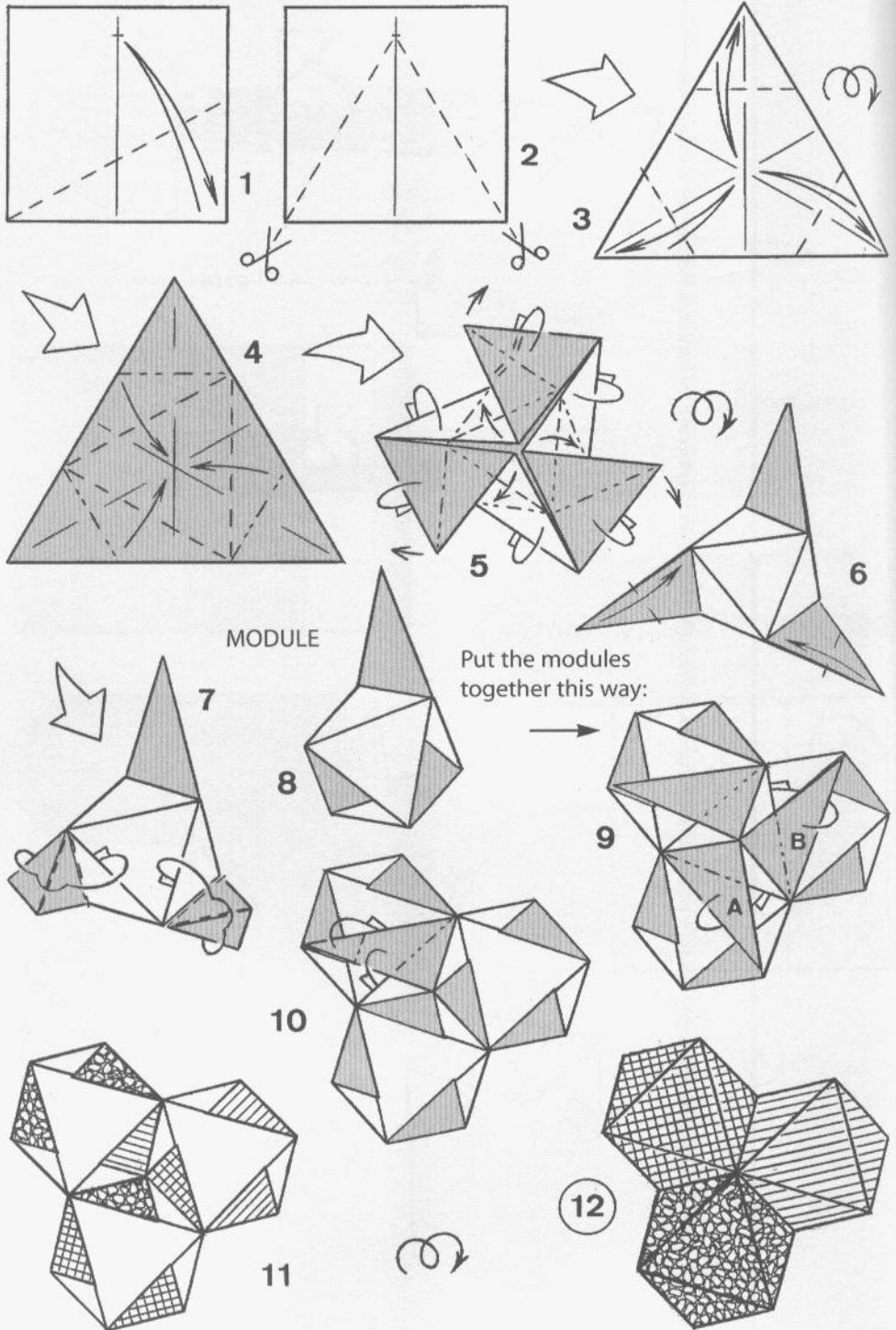

LITTLE DOG 1

by Fred Rohm

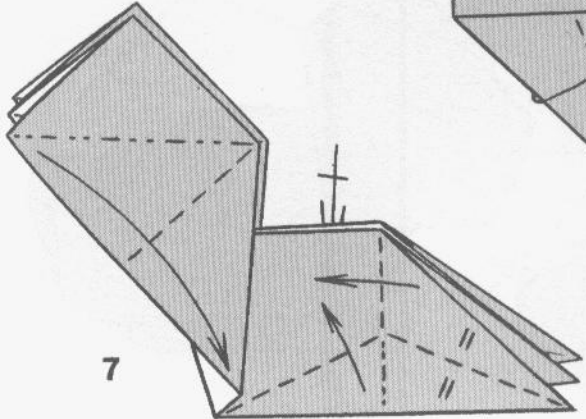
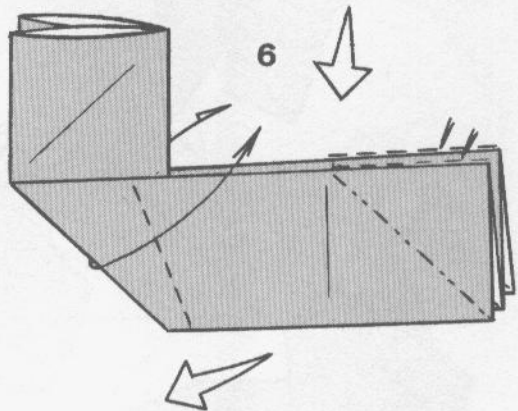
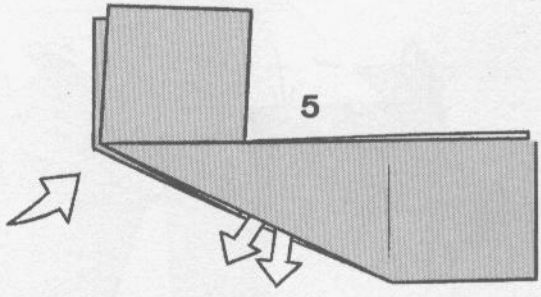
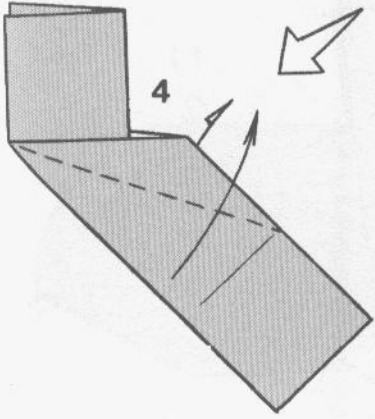
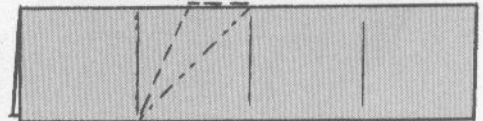
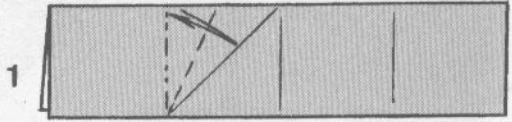
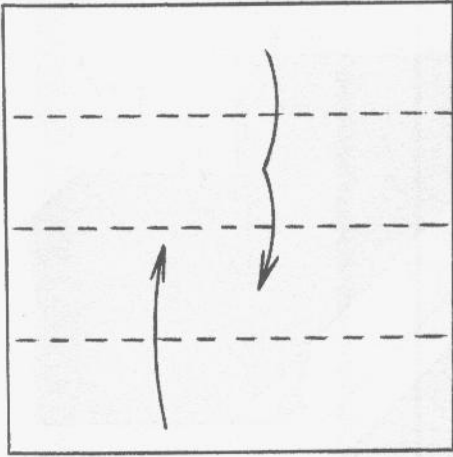

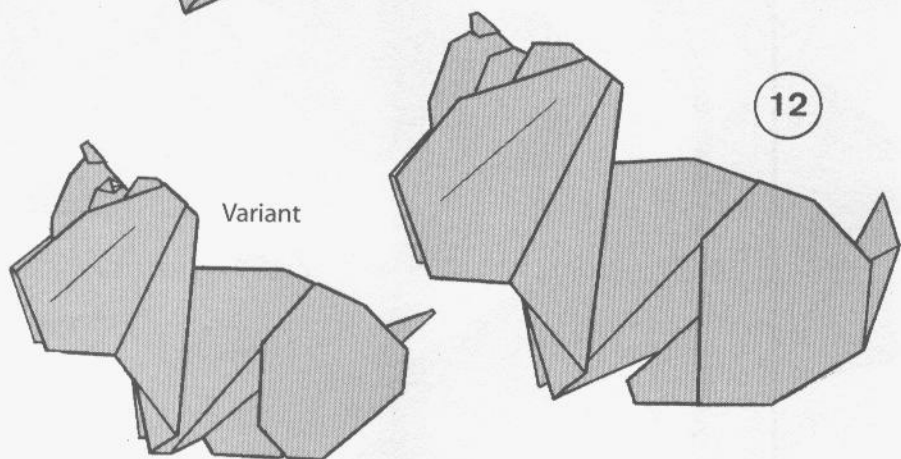
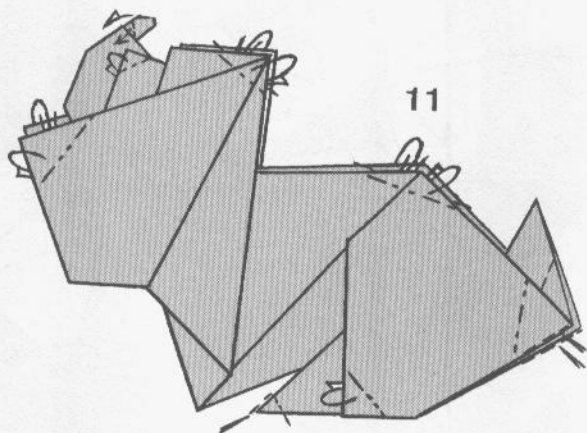
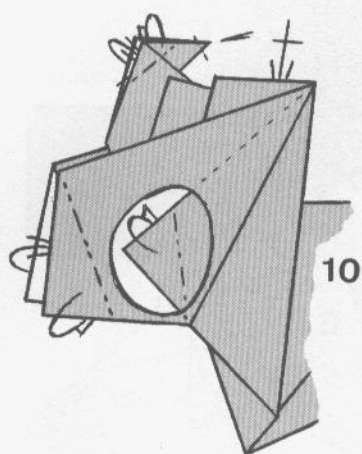
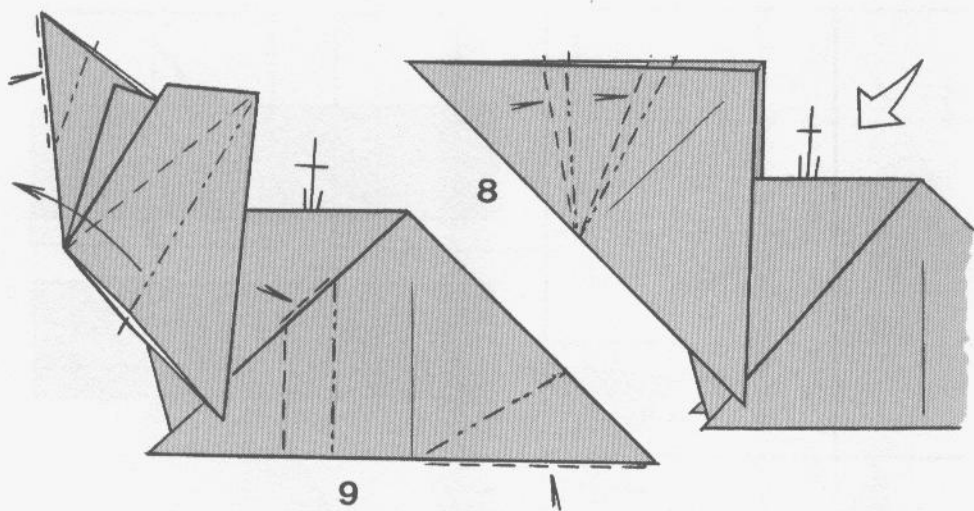

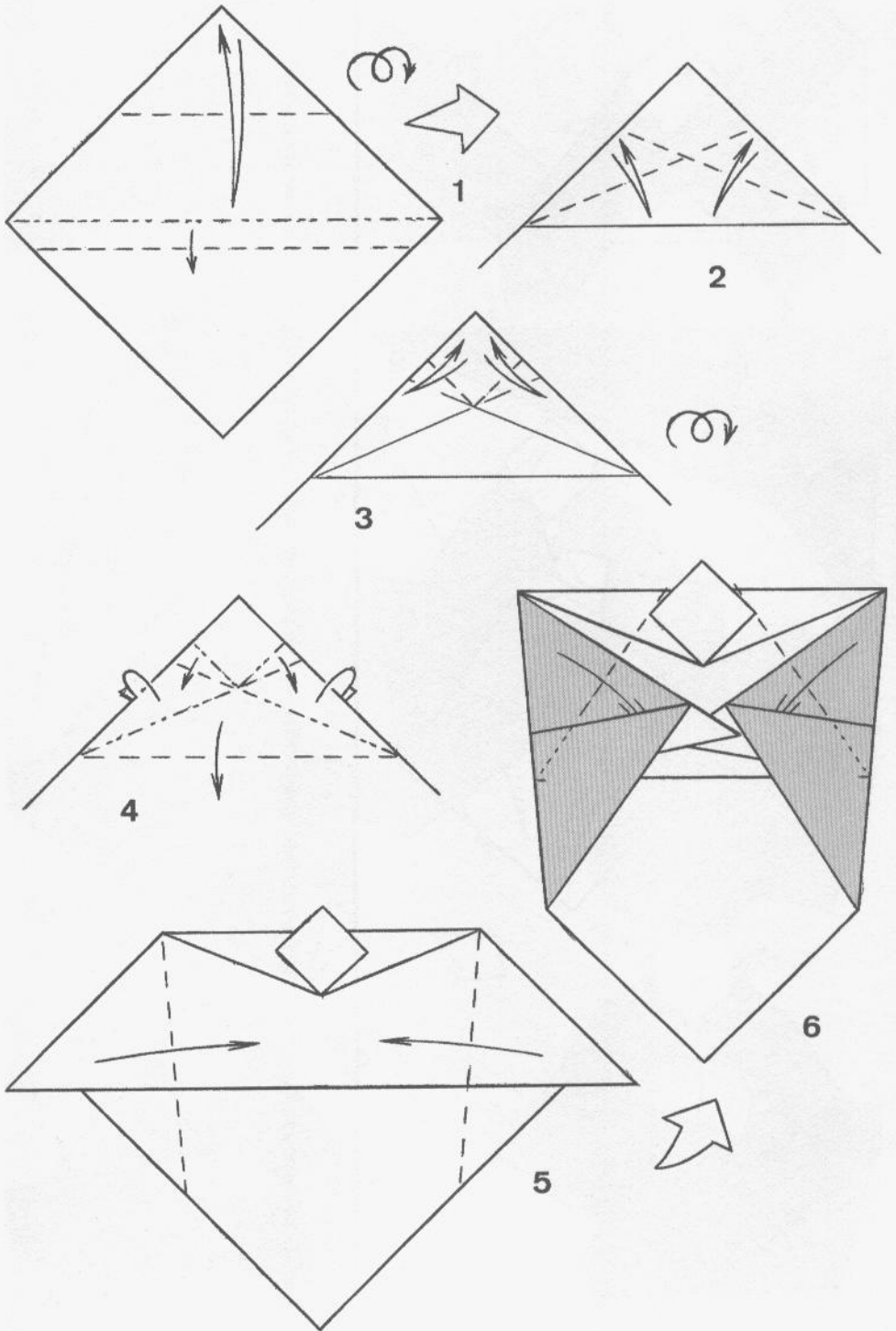

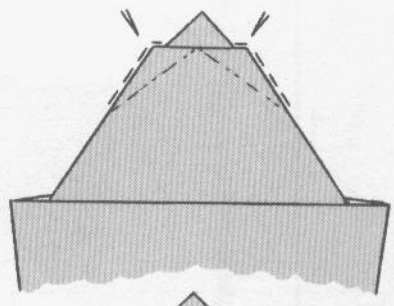
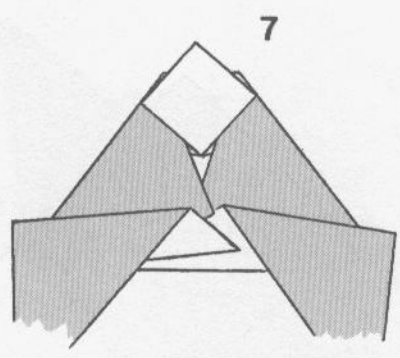

8

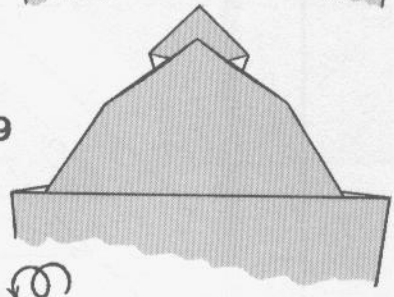

9

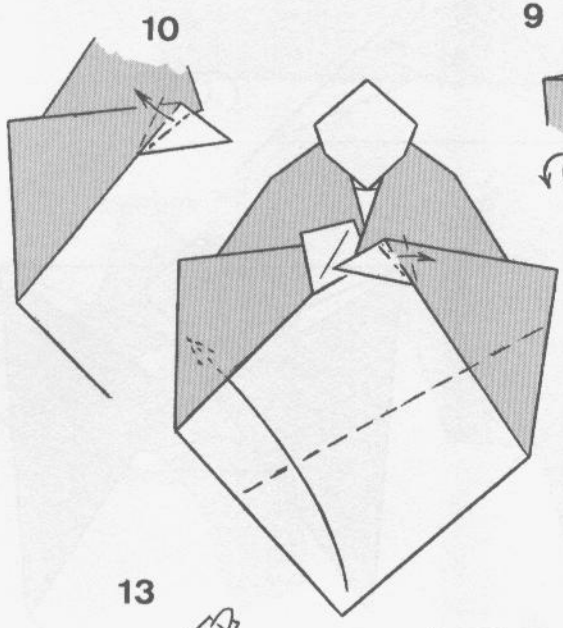

10

11

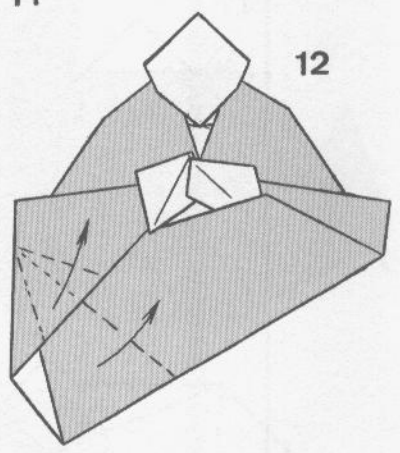

12

13

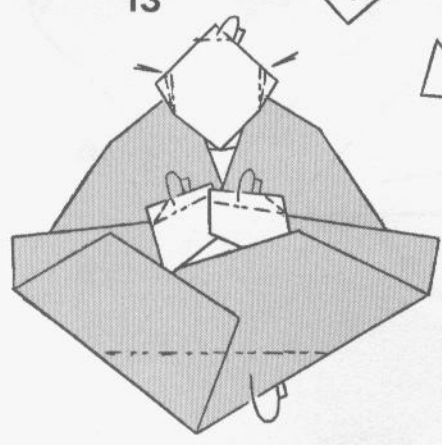

14

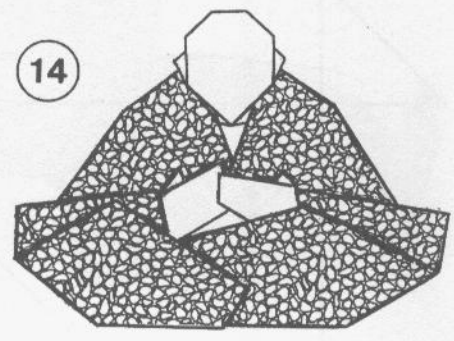

SWAN

by Yoshihide Momotani (1970)

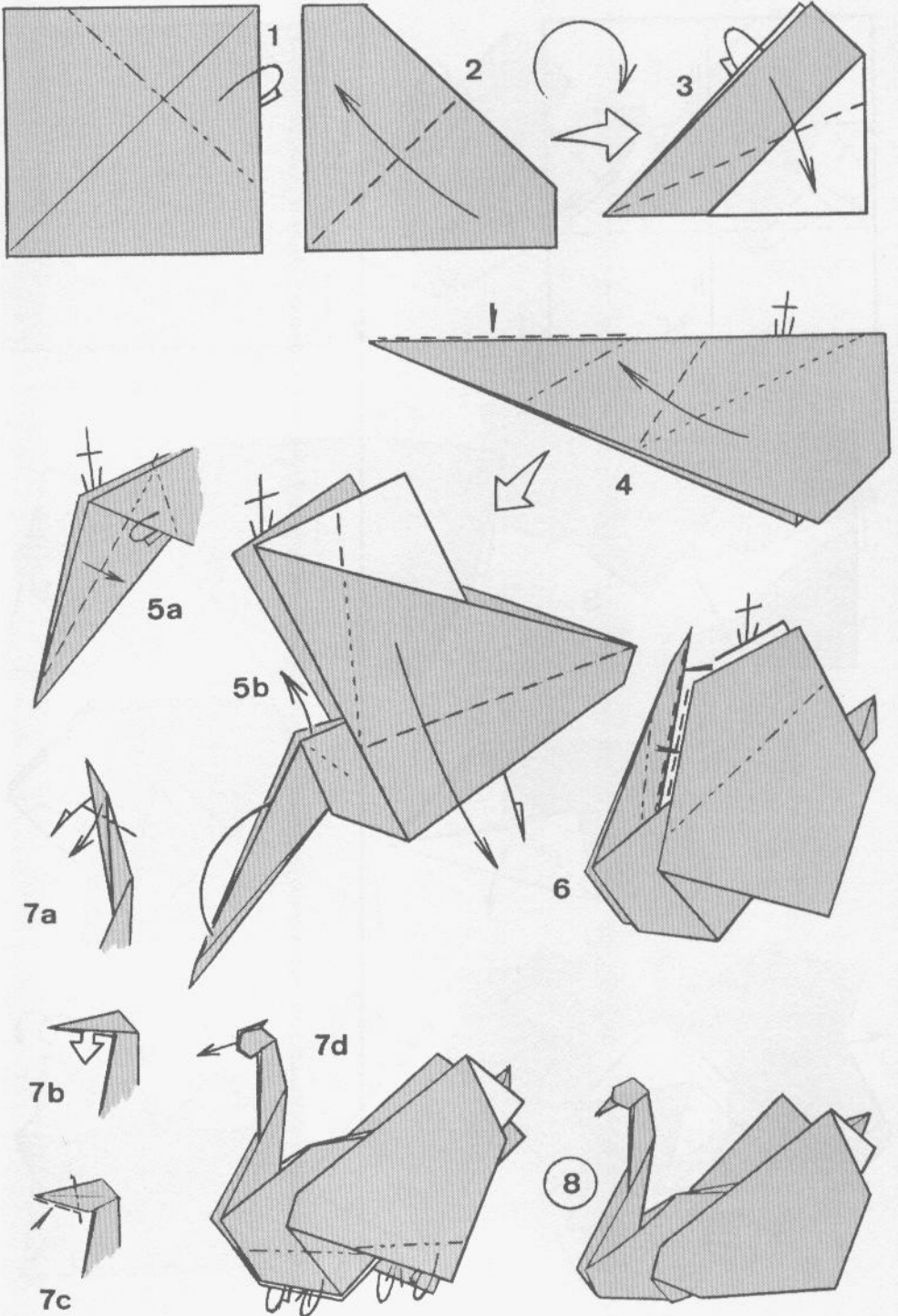

WILFRED'S CROWN

by José Meeusen (1997)

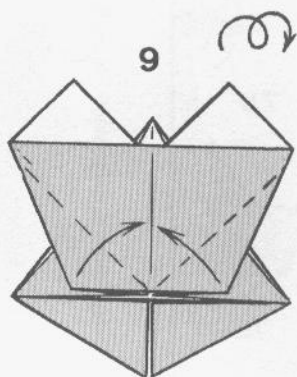
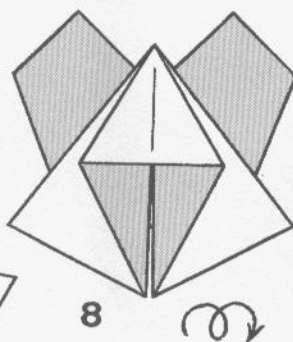
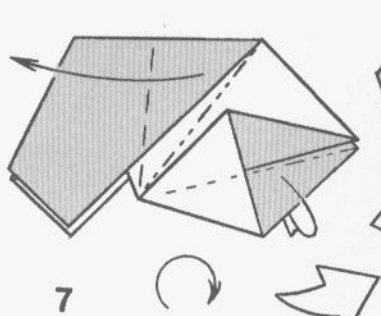
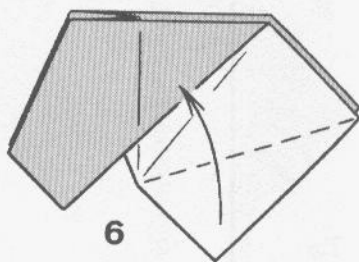
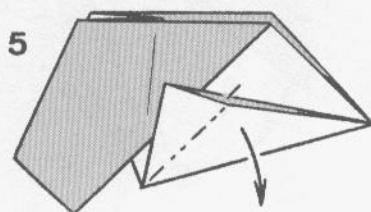
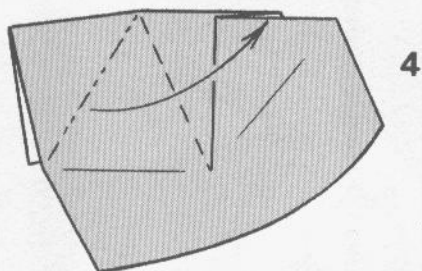
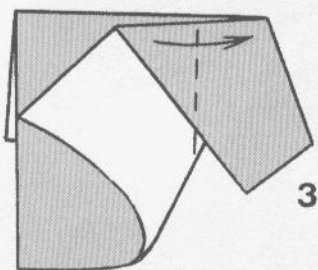
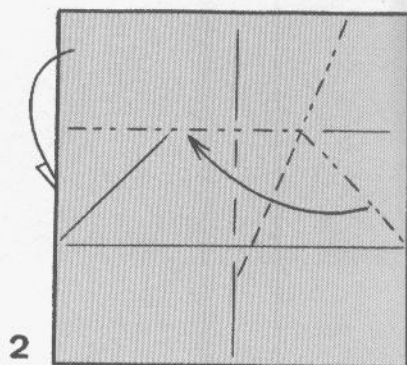
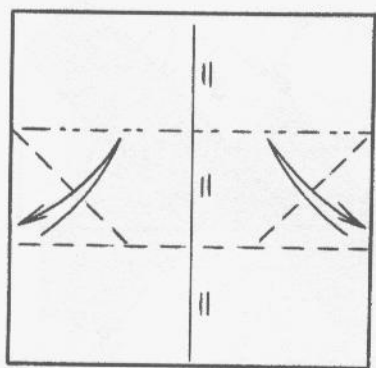

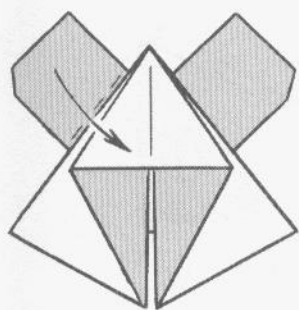

10

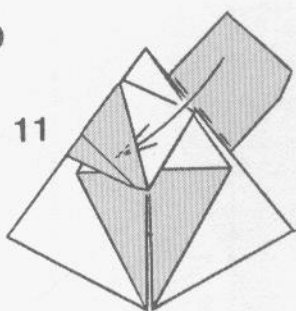

11

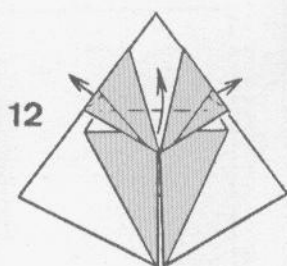

12

Make **6** modules and put them together this way:

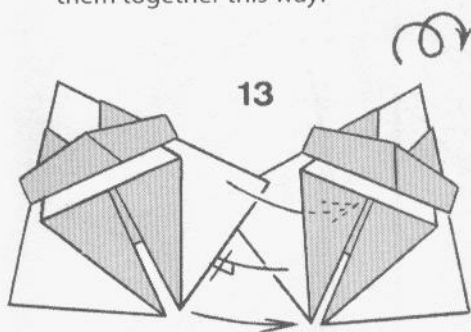

13

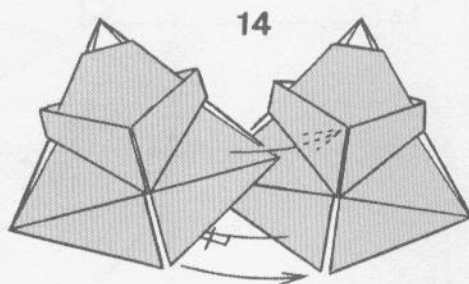

14

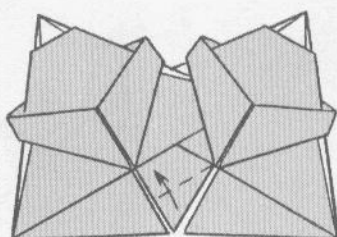

15

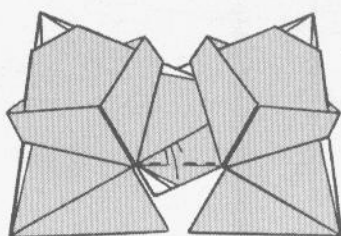

16

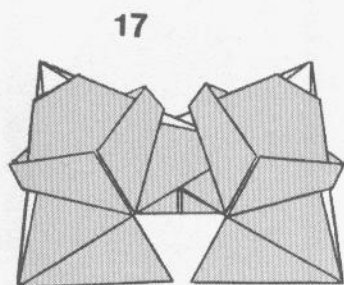

17

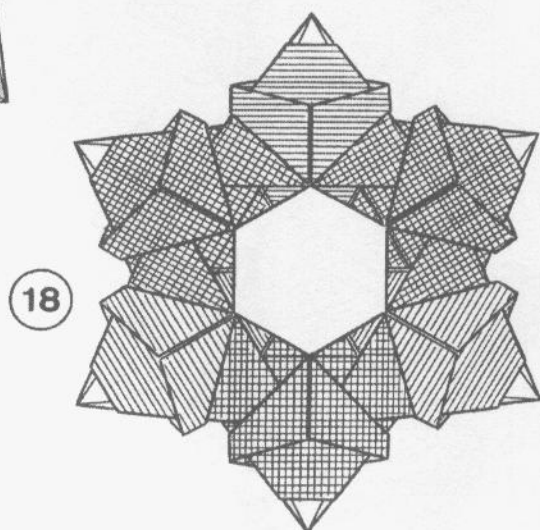

18

SEVEN-MODULE CROWN

by José Meeusen

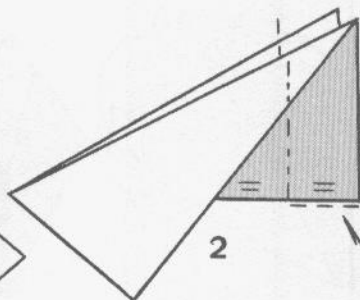
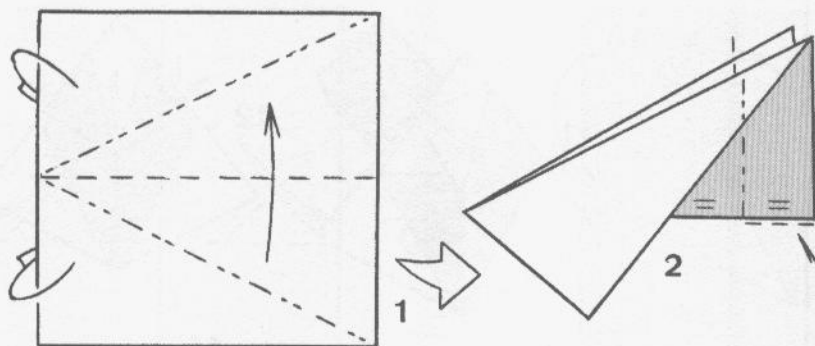

Join 7 modules this way:

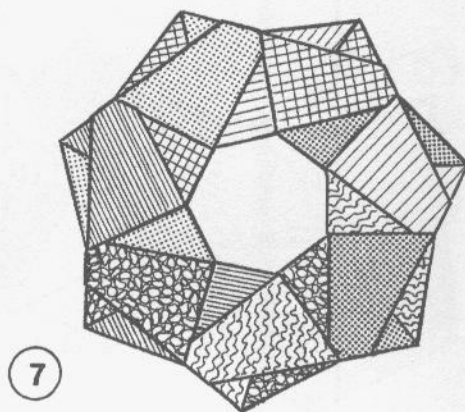
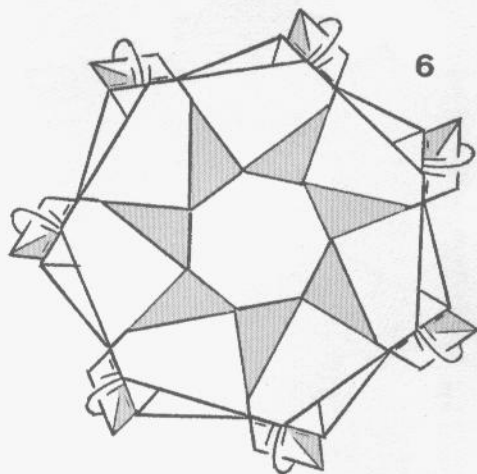
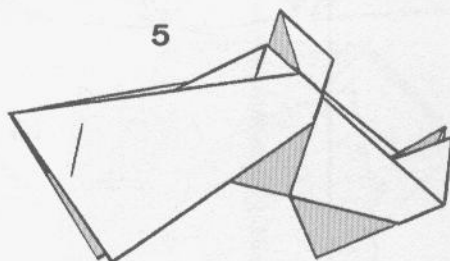
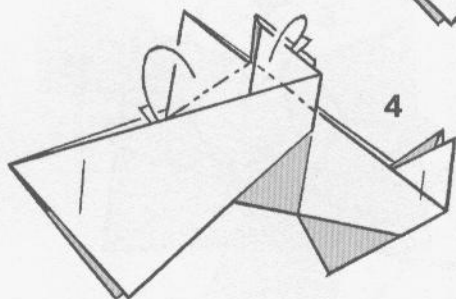
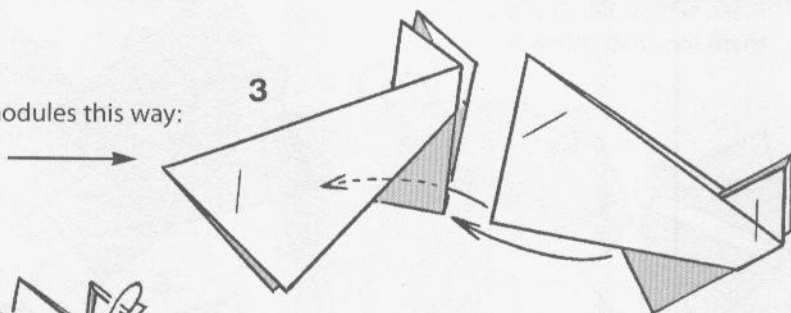

EIGHT-MODULE STAR 1

by José Meeusen

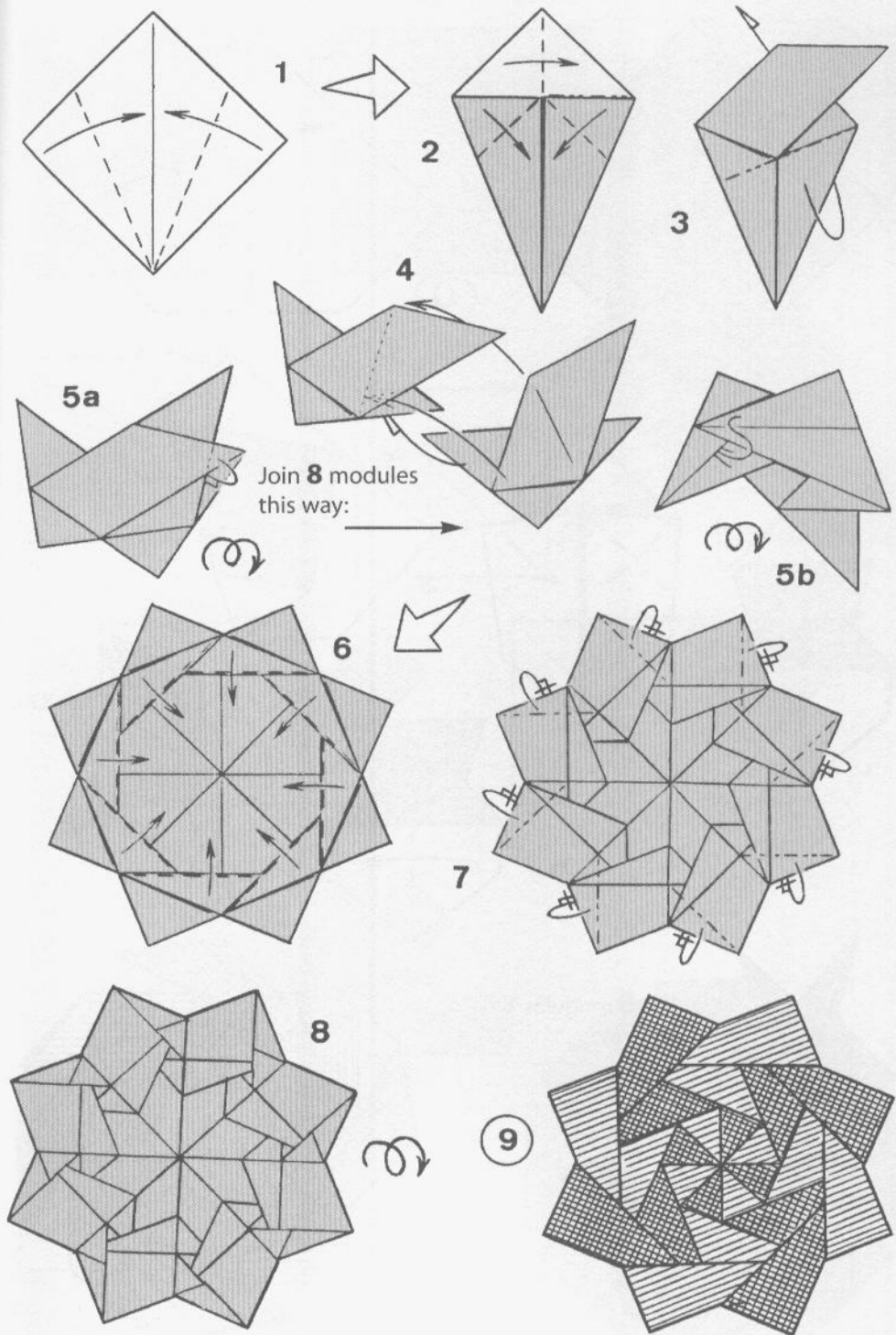

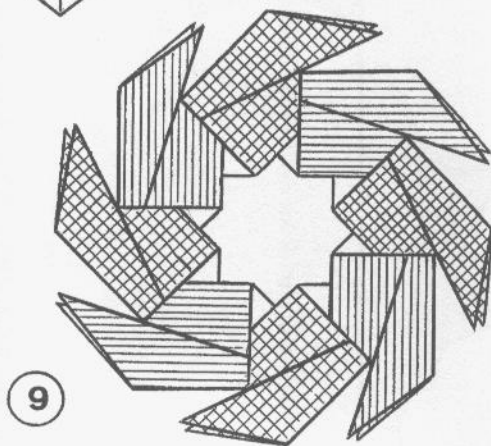
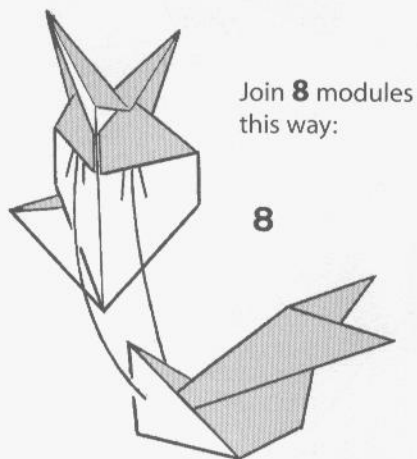
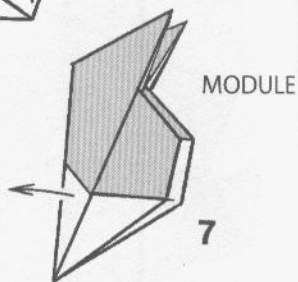
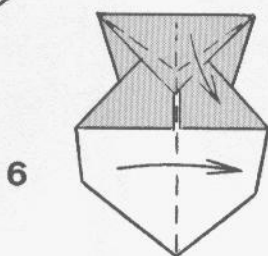
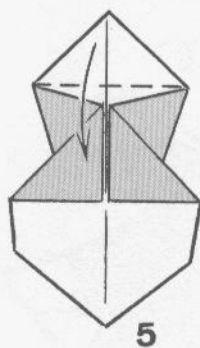
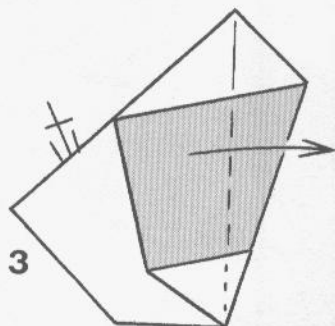
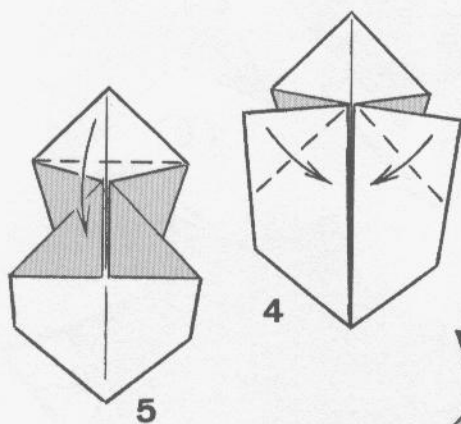
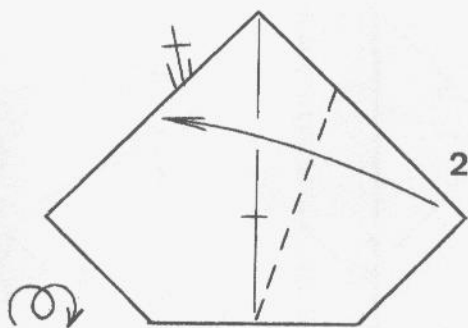
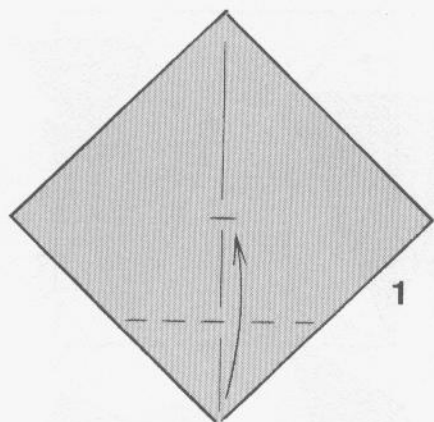

WREATH

by José Meeusen

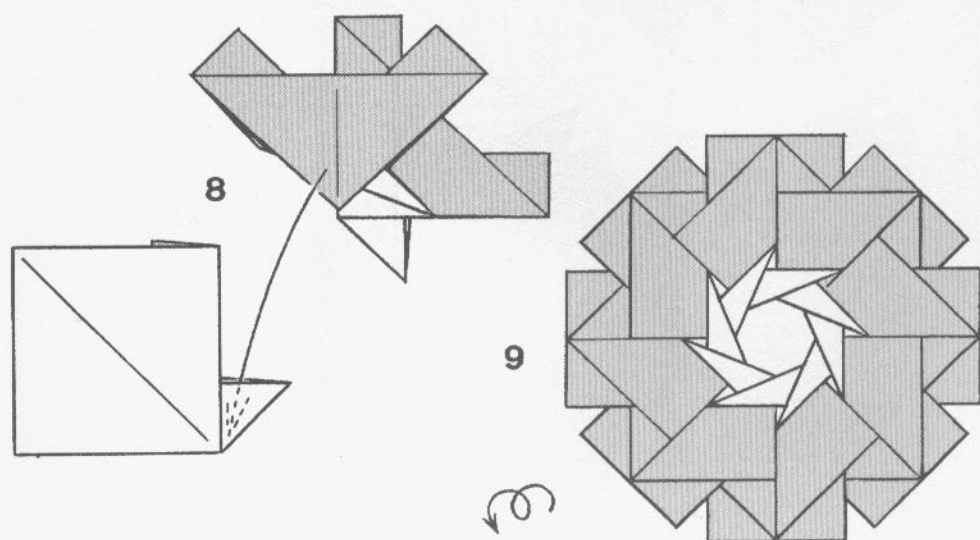
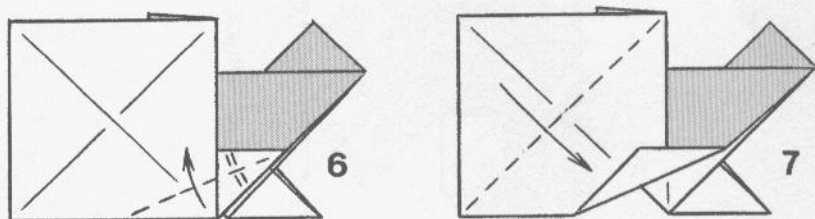
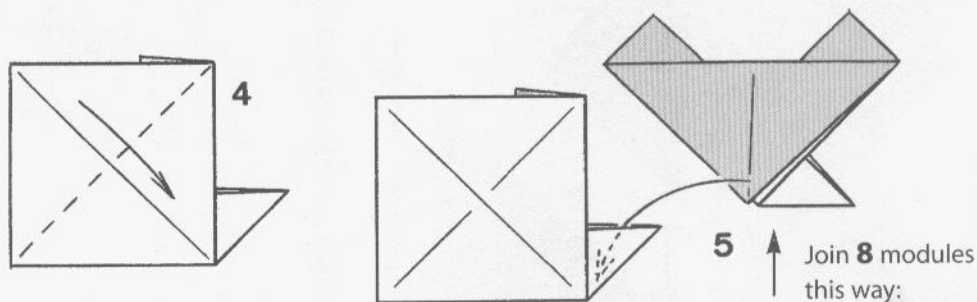
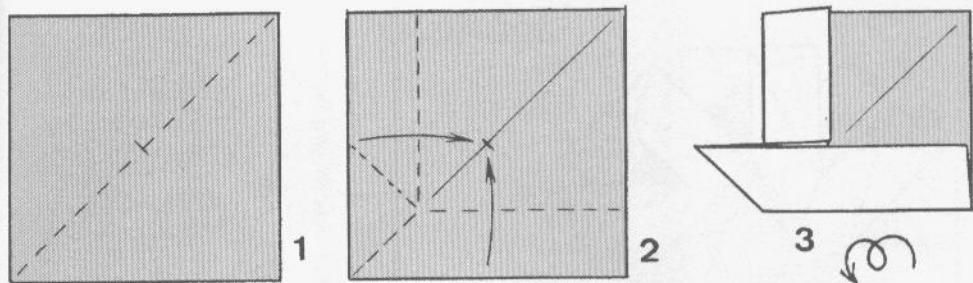

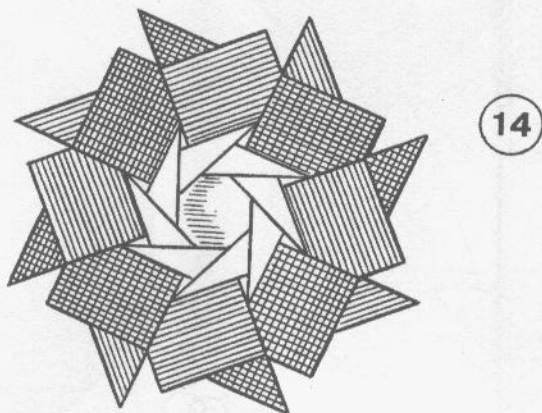
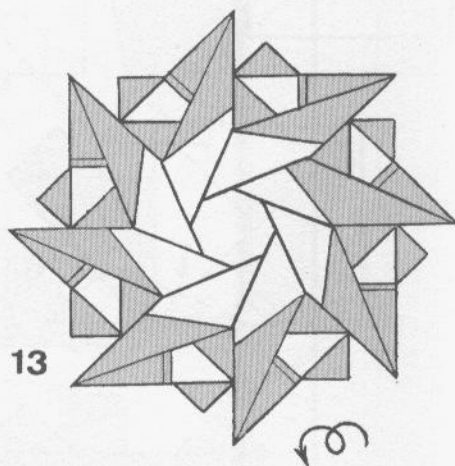
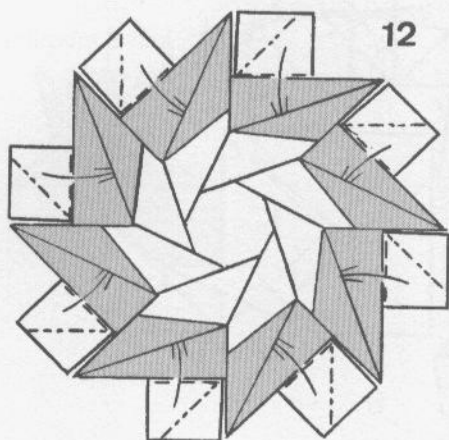
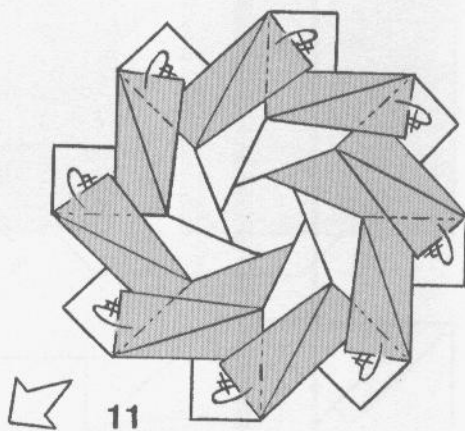
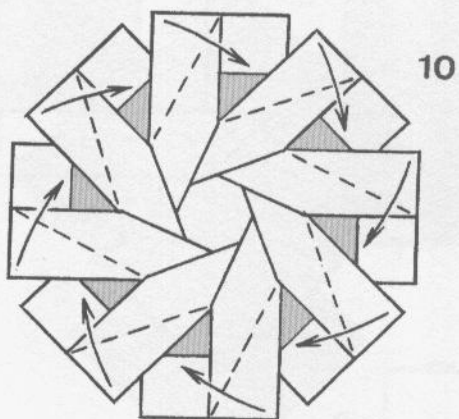

FOLDS STARTING WITH HEXAGONAL PAPER

HEXAGON

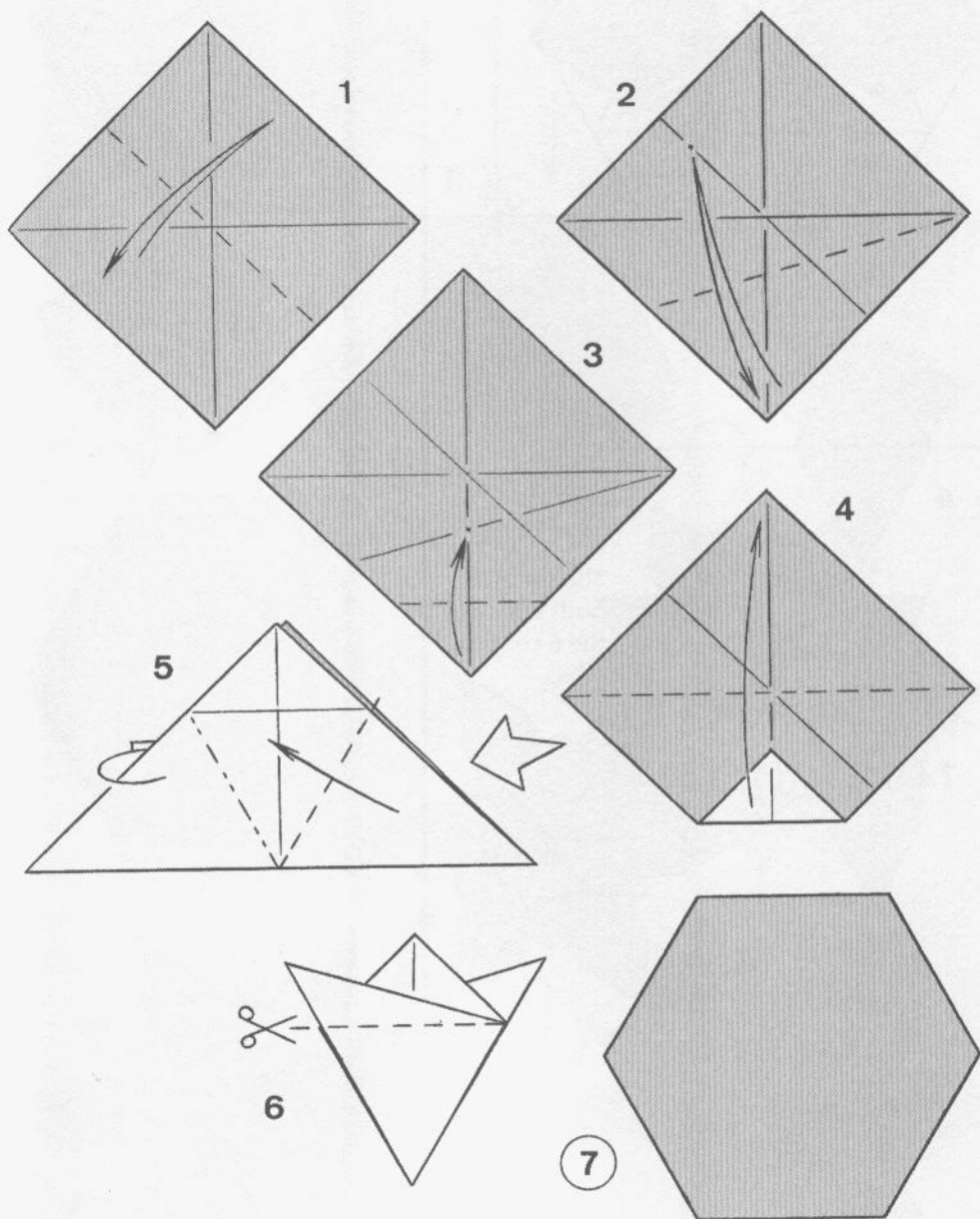

STAR 1

by Lewis Simon

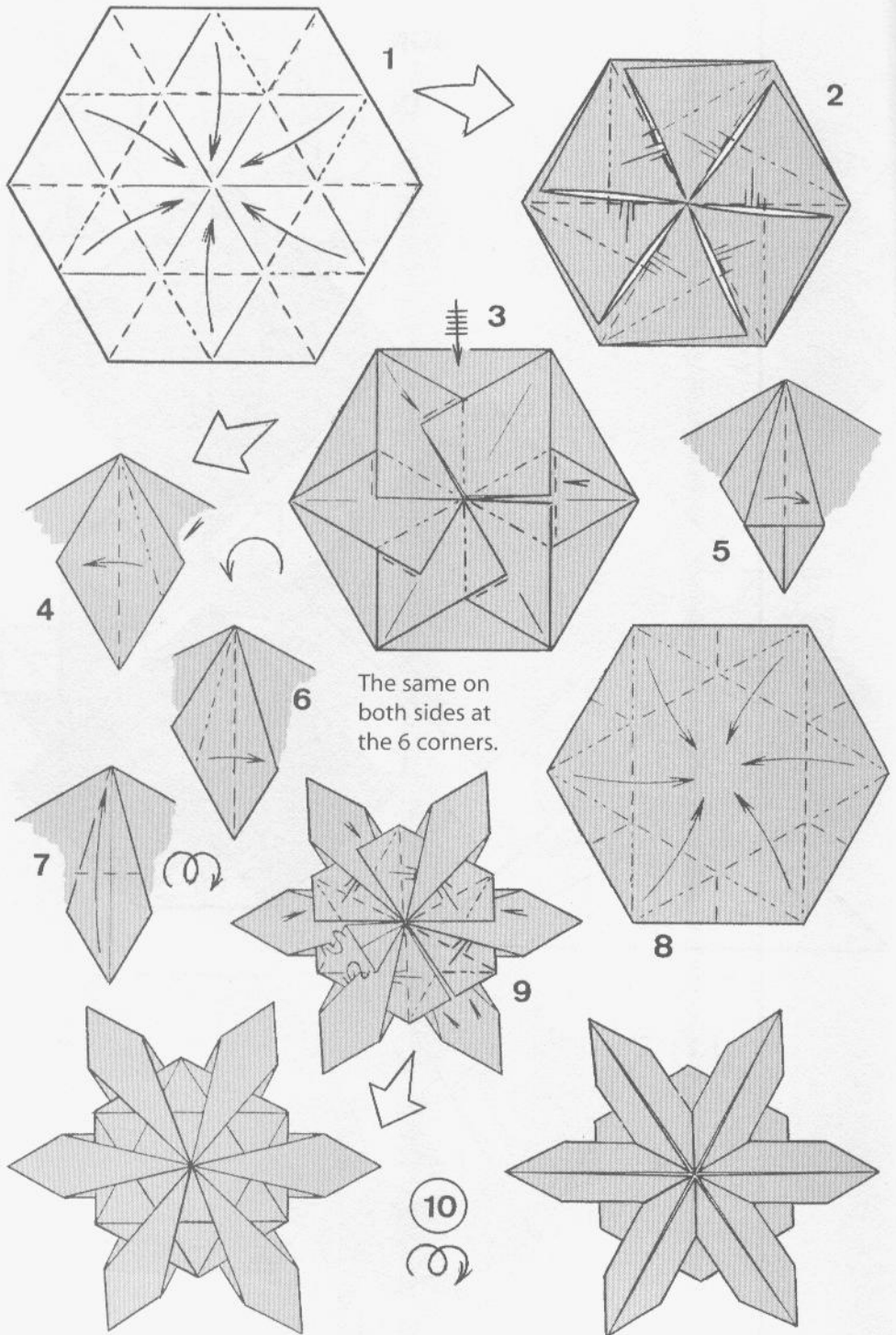

STAR 2

by Lewis Simon

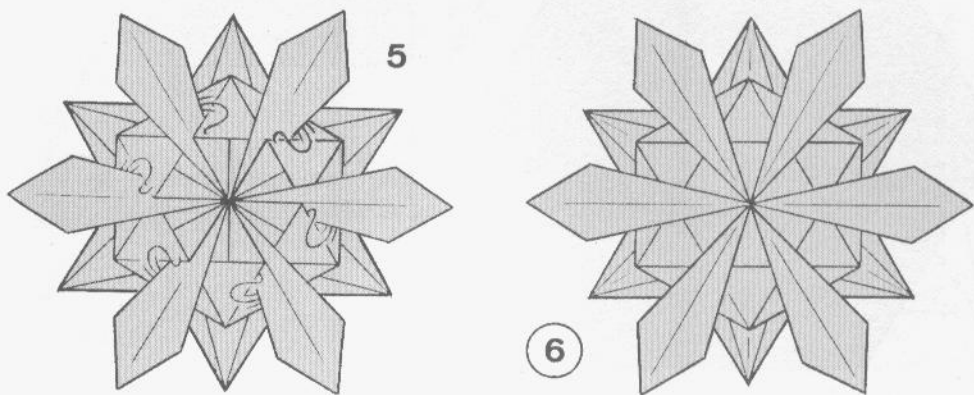
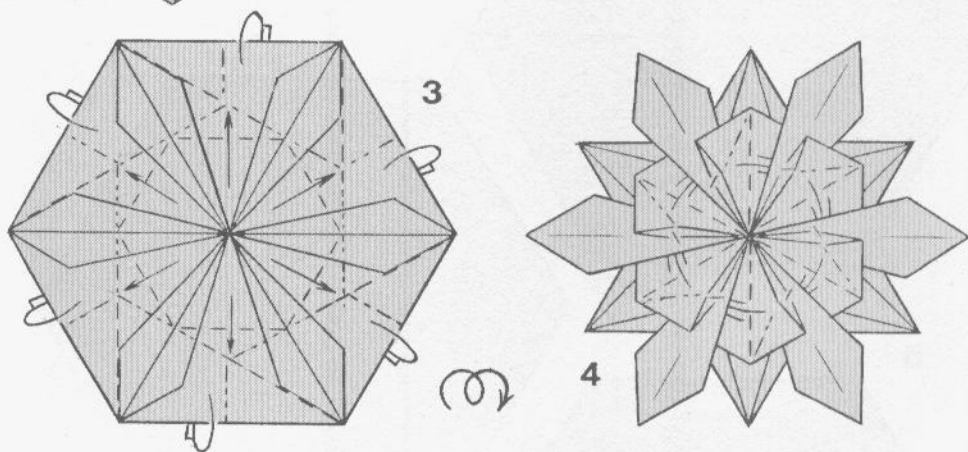
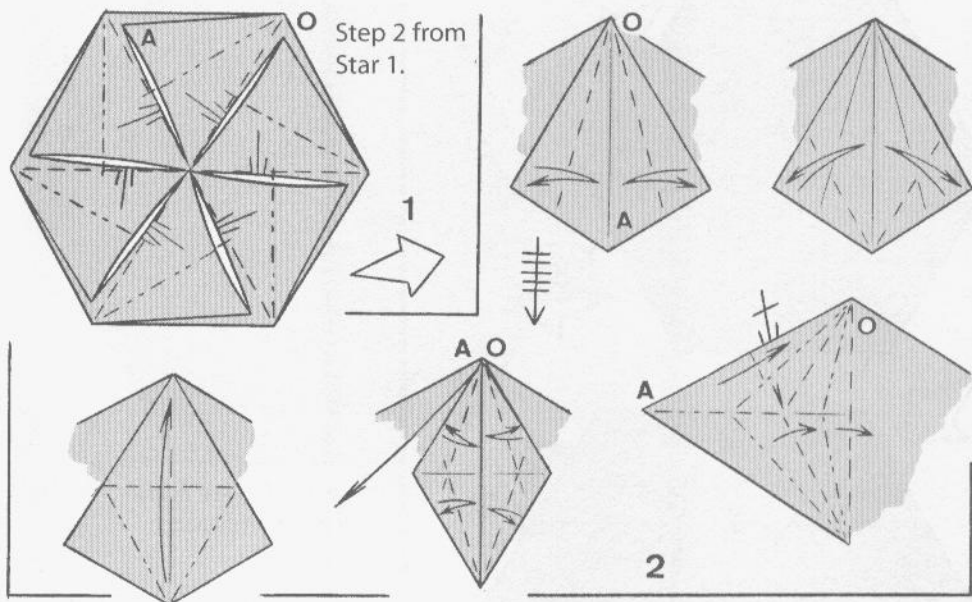

KNICKKNACK

by Luis Fernández

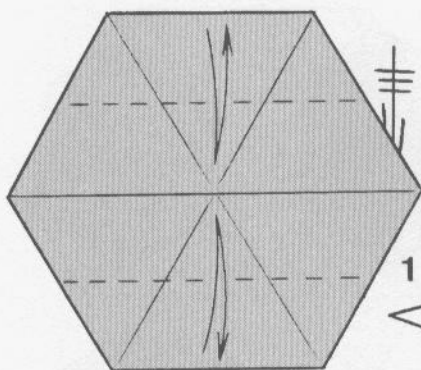

1

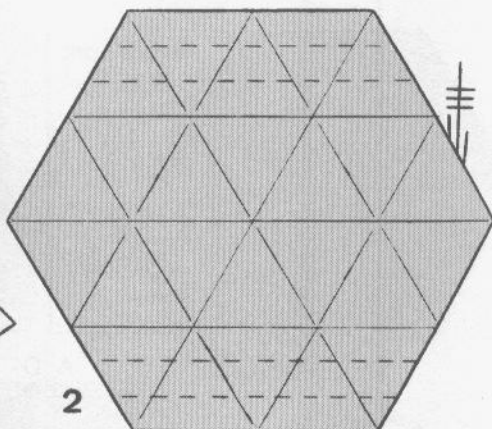

2

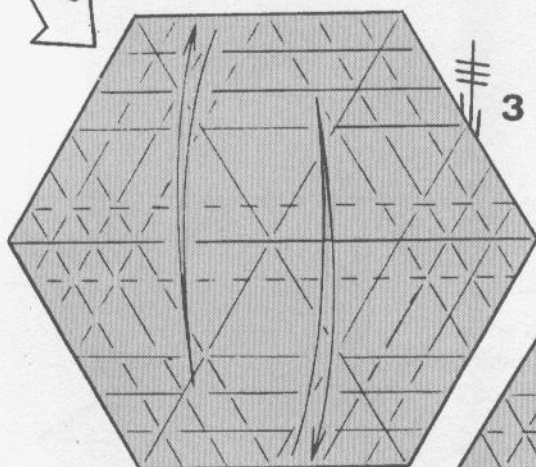

3

Crease all of these folds, in the order indicated.

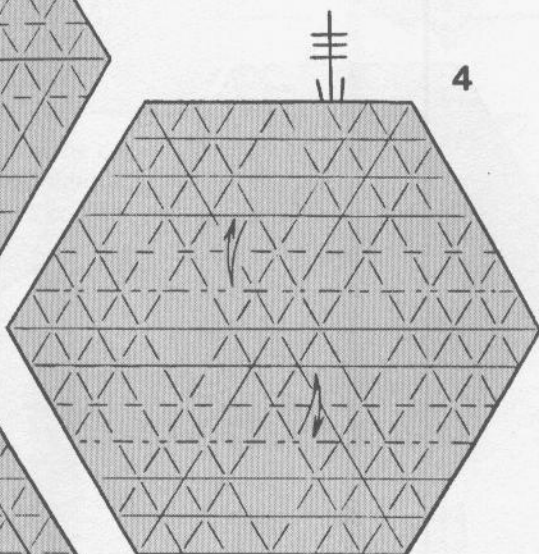

4

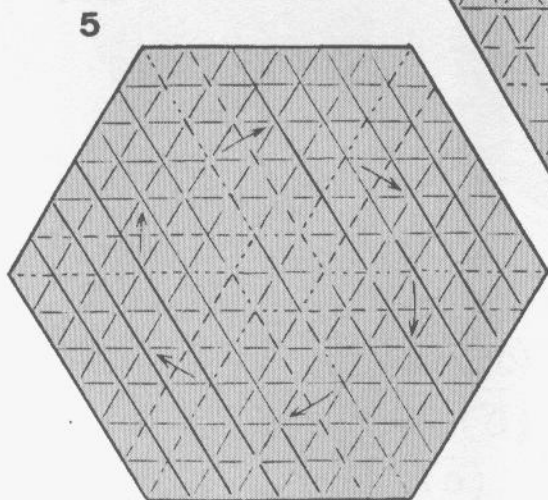

5

Paper more than 8 inches at its widest point is best to make this figure.

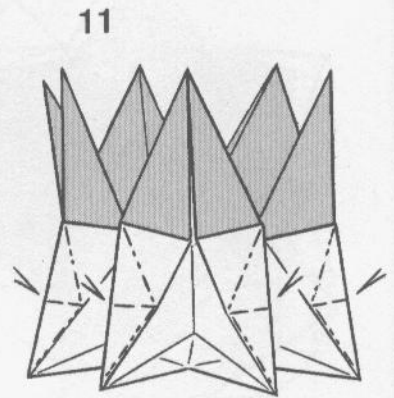
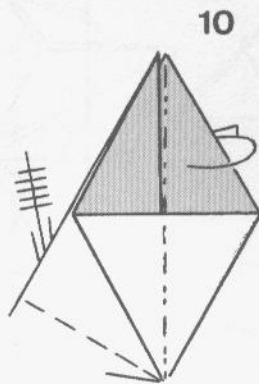
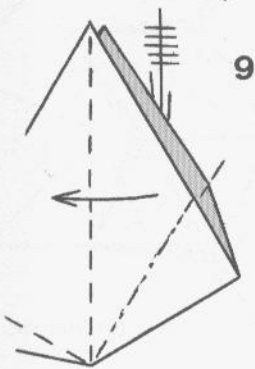
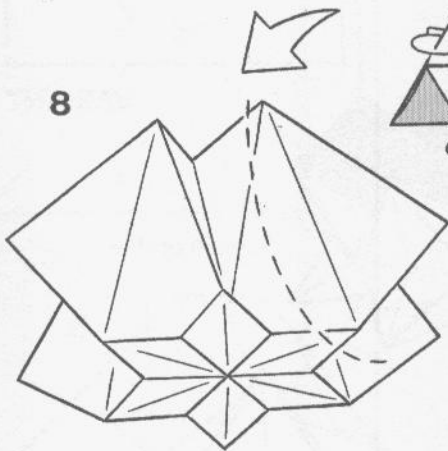
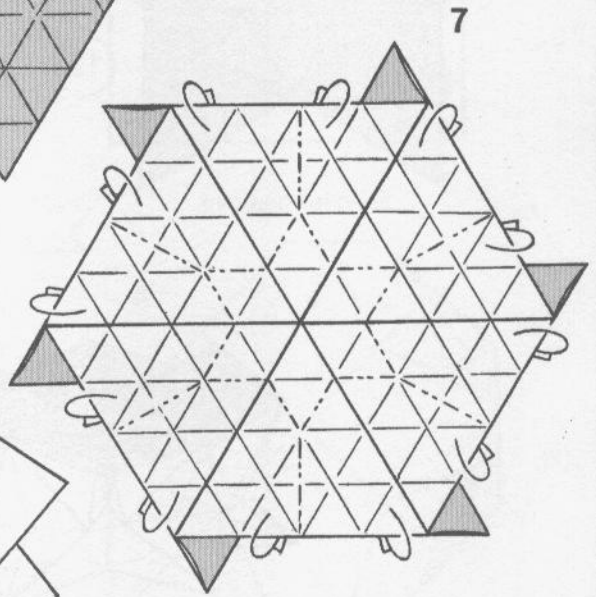
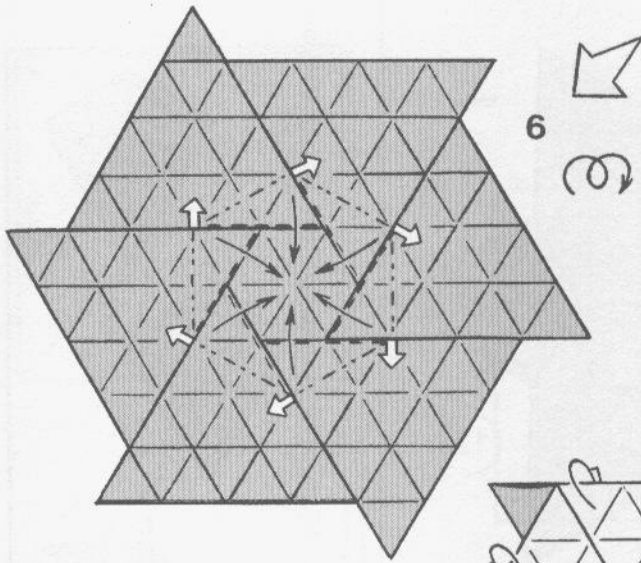

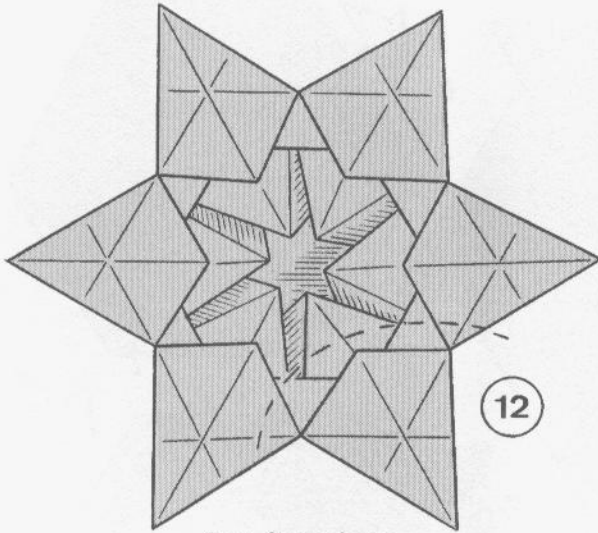

Seen from above.

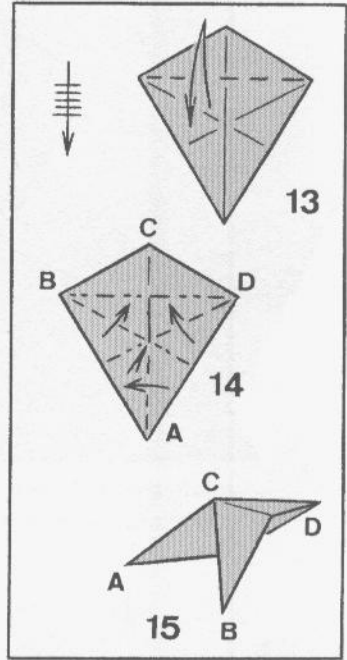

VARIANT

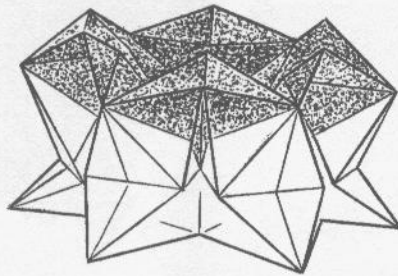

Seen in profile.

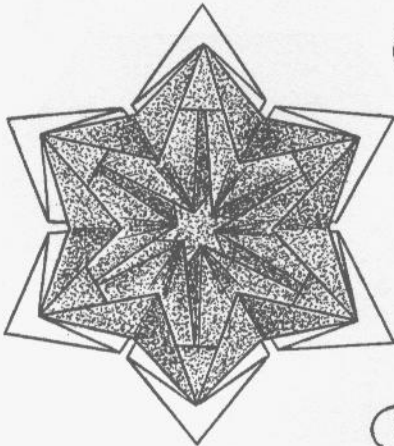

Seen from above.

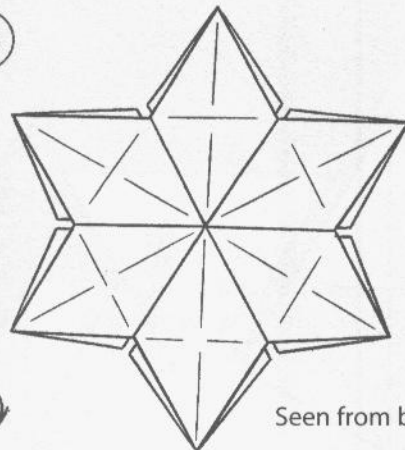

Seen from below.

FIVE-POINT STAR (with cutting)

by Daniel Geriant

Use thin paper.

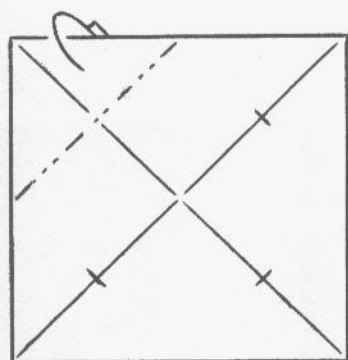

1

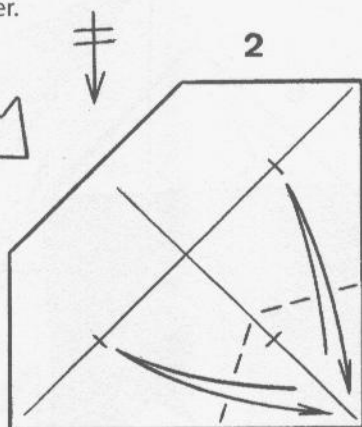

2

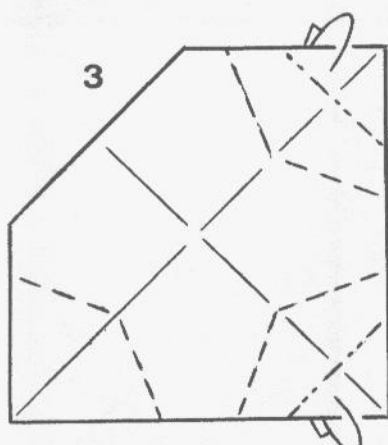

3

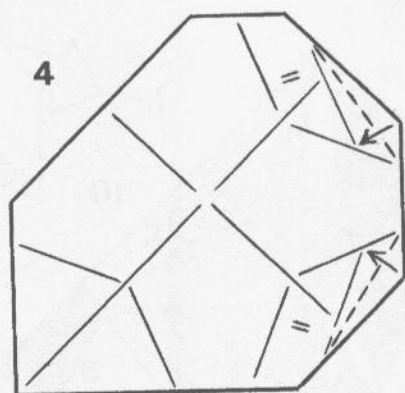

4

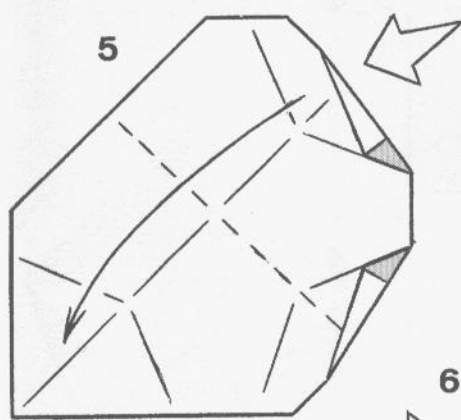

5

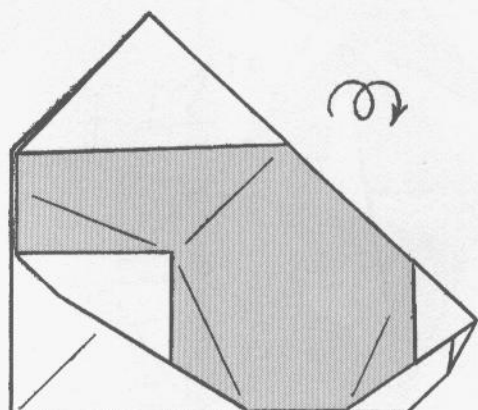

6

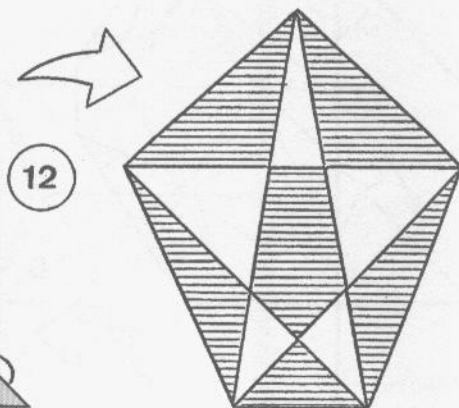
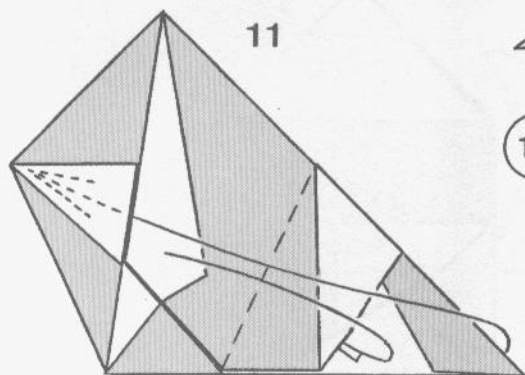
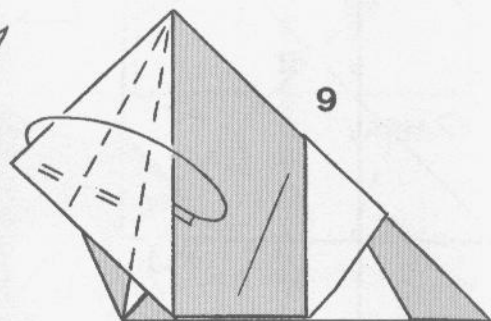
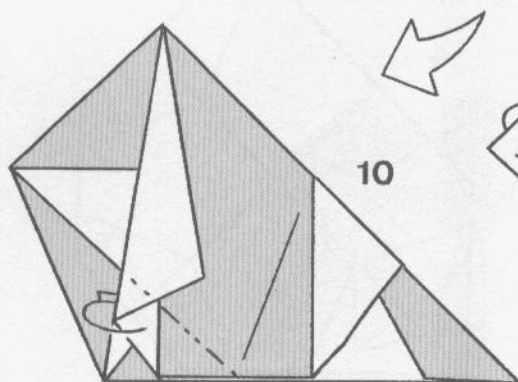
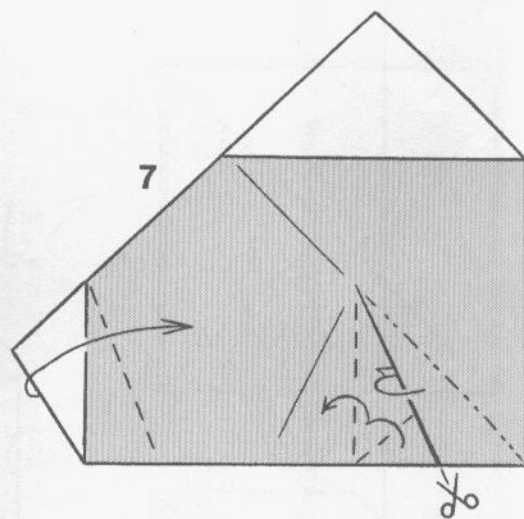
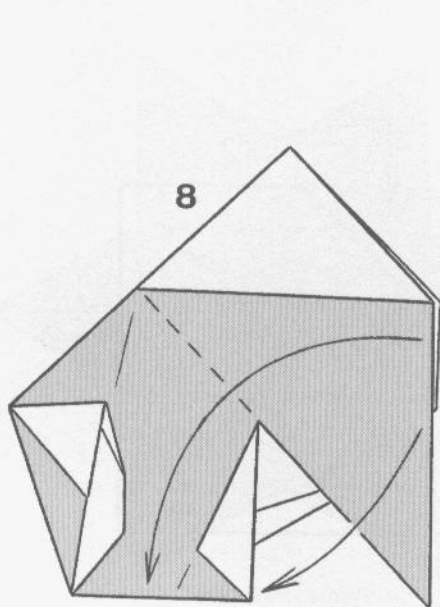

LITTLE WHALE

by Juan López Figueroa

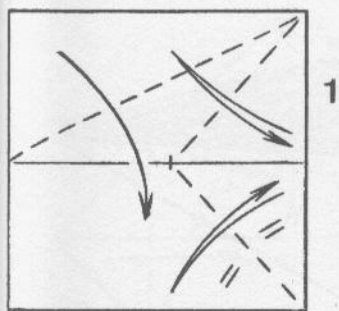

Metallic-foil paper
is suitable.

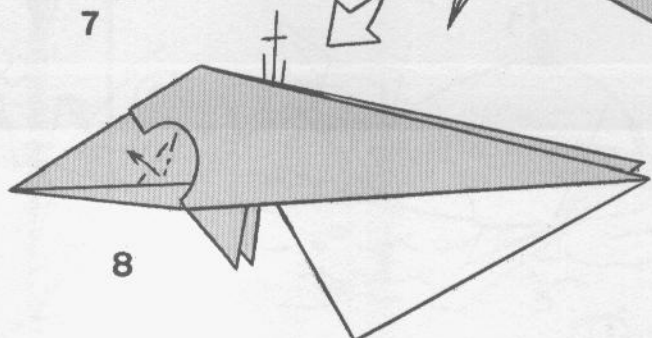
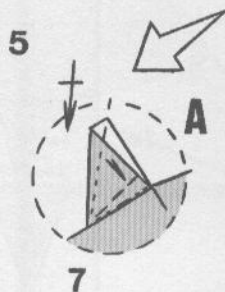
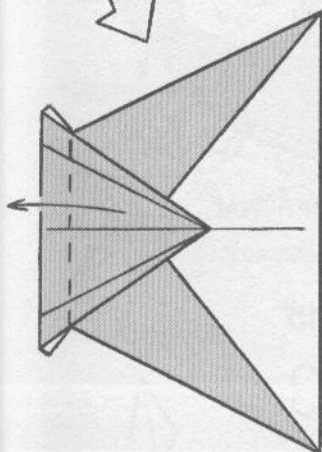
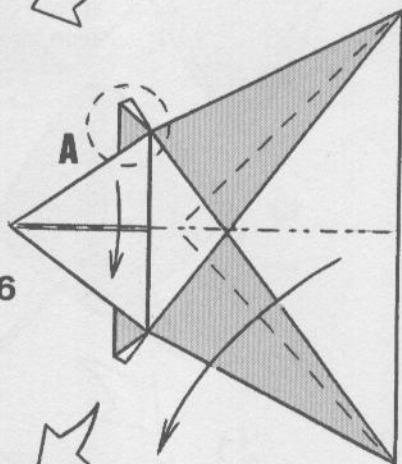
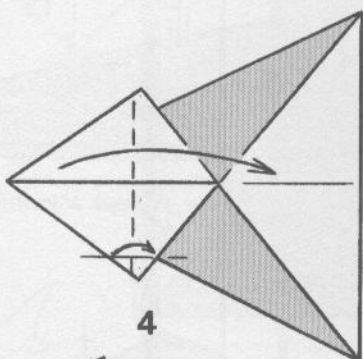
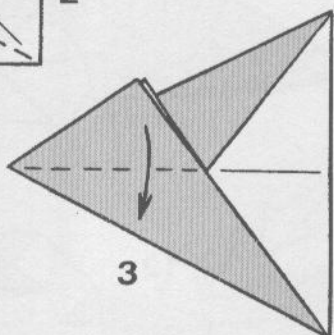
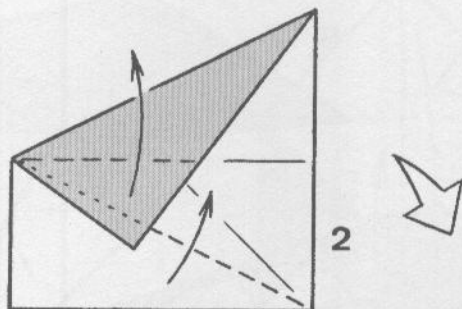

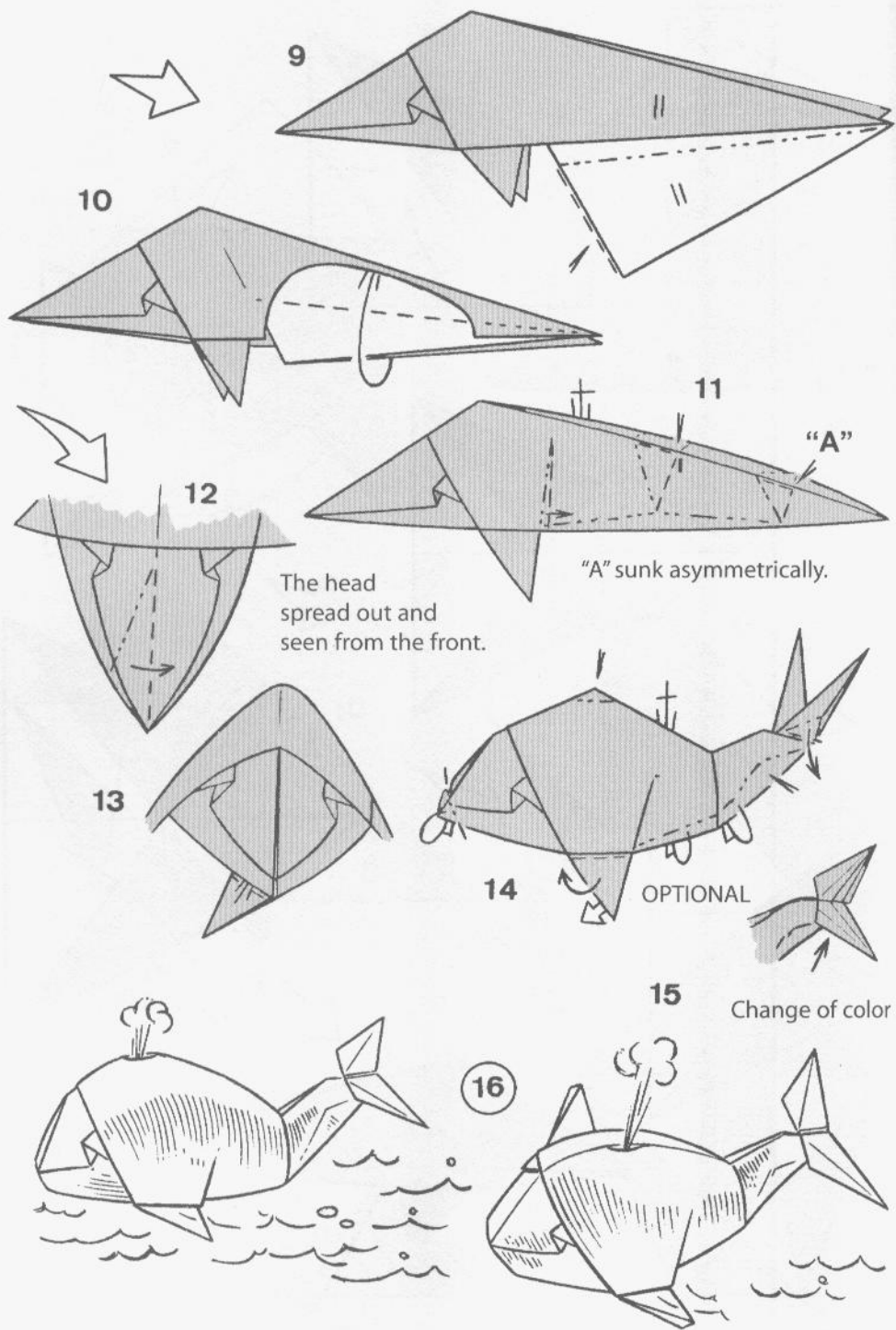

9

10

11

12

13

14

15

16

The head spread out and seen from the front.

"A" sunk asymmetrically.

OPTIONAL

Change of color

BOXER DOG

by Juan López Figueroa

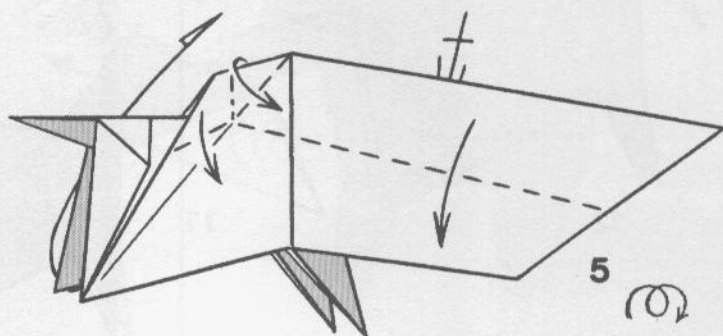
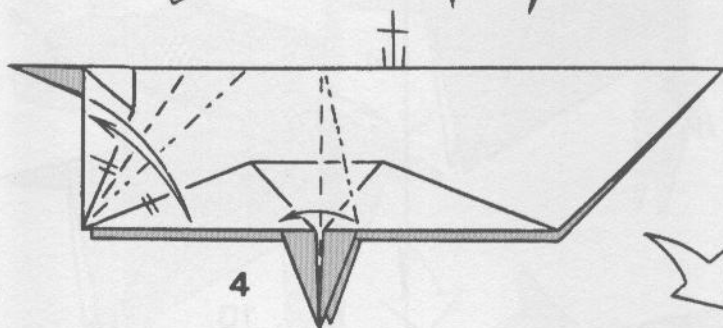
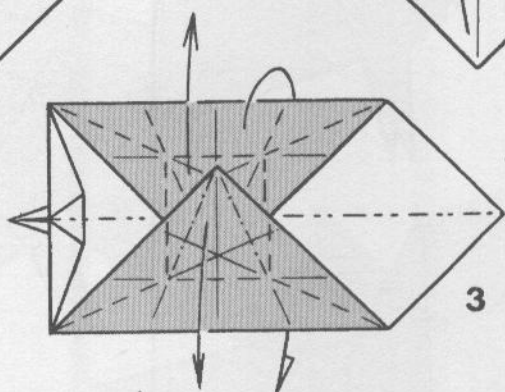
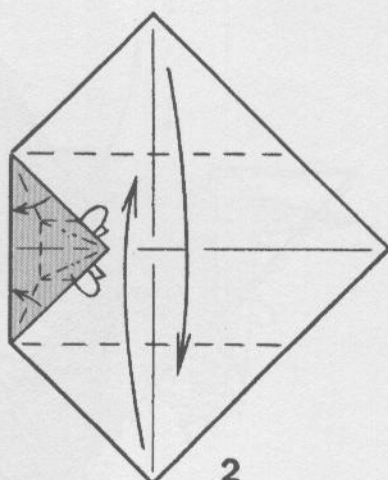
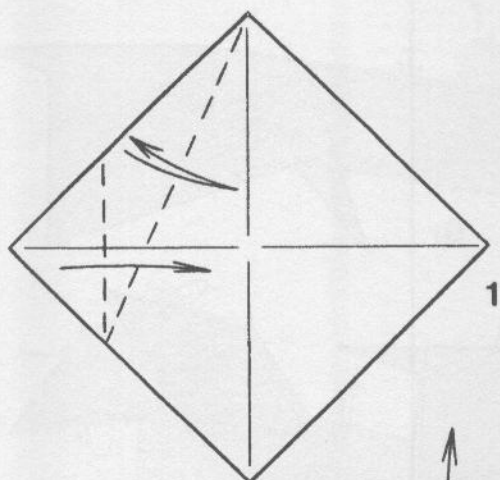

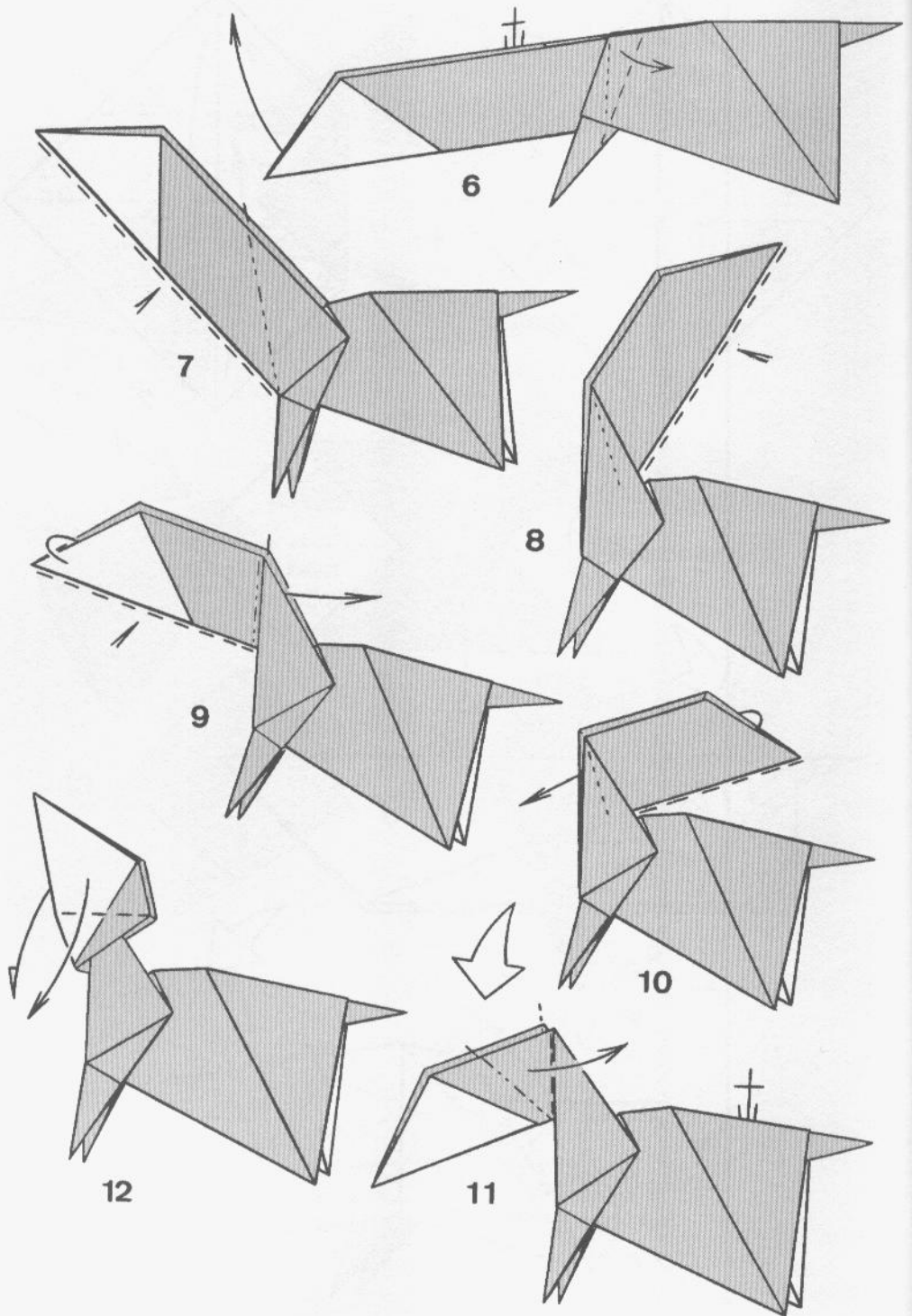

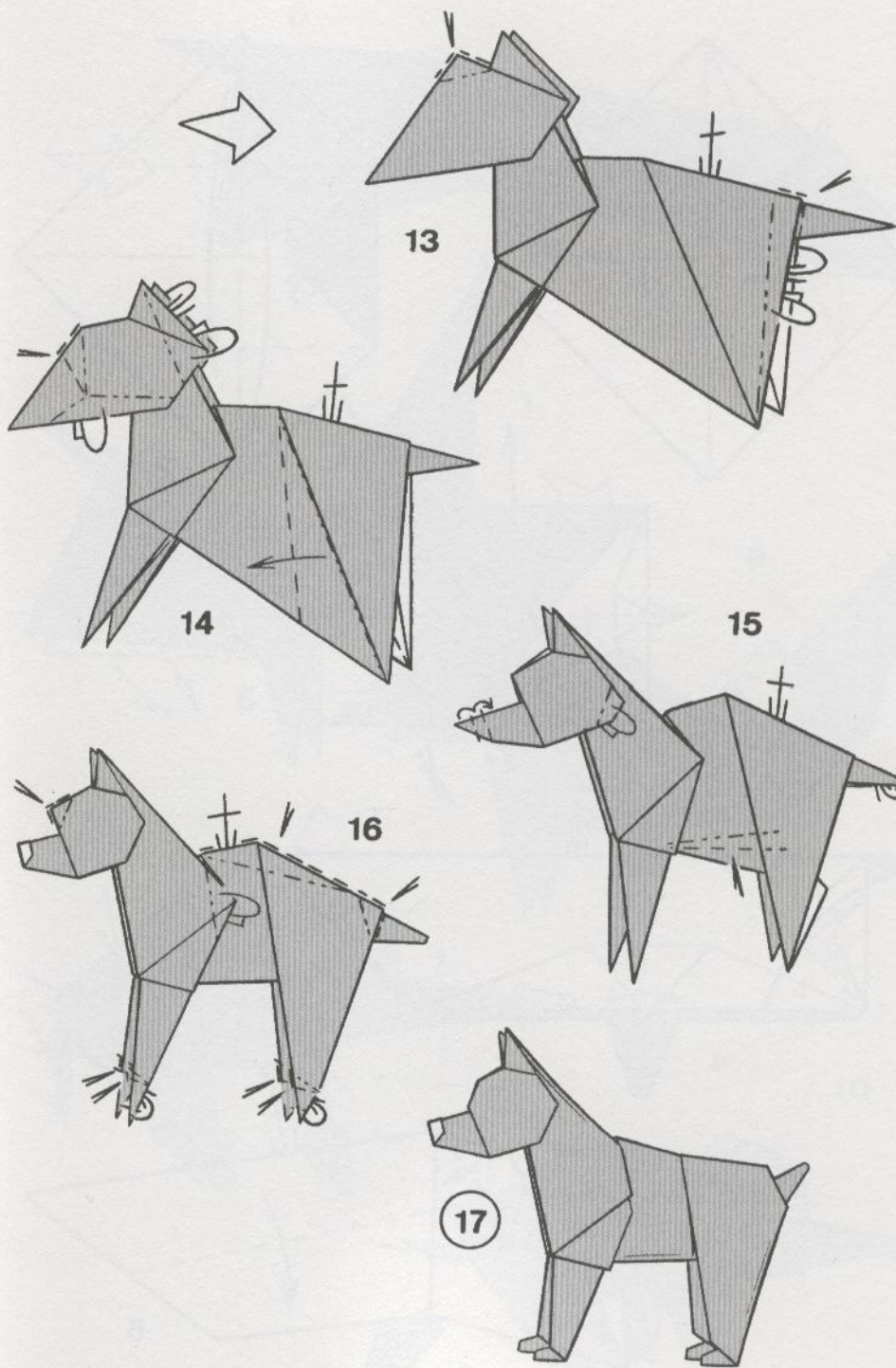

ELEPHANT

by Juan López Figueroa

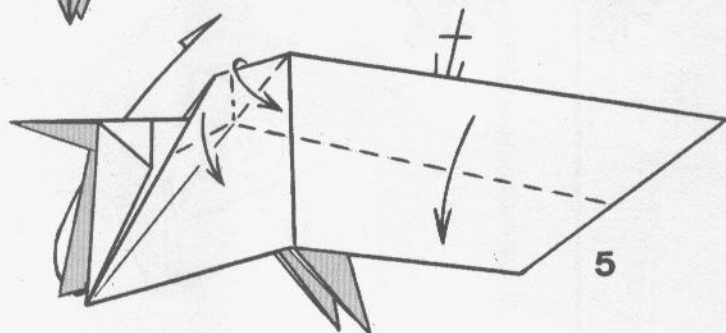
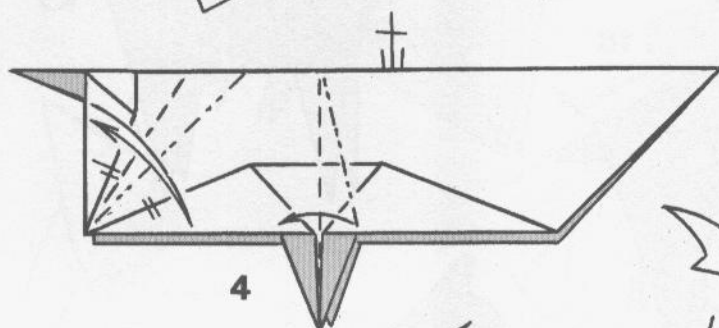
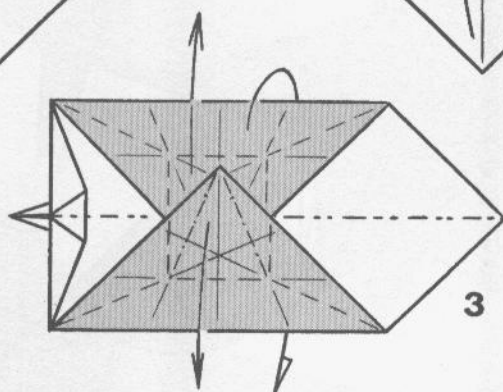
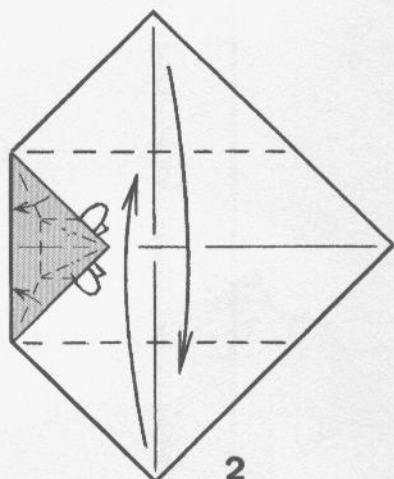
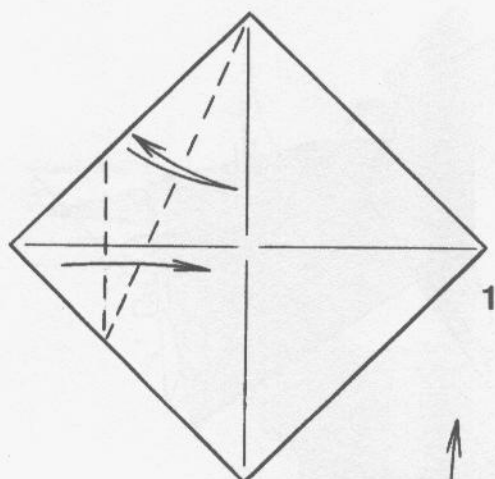

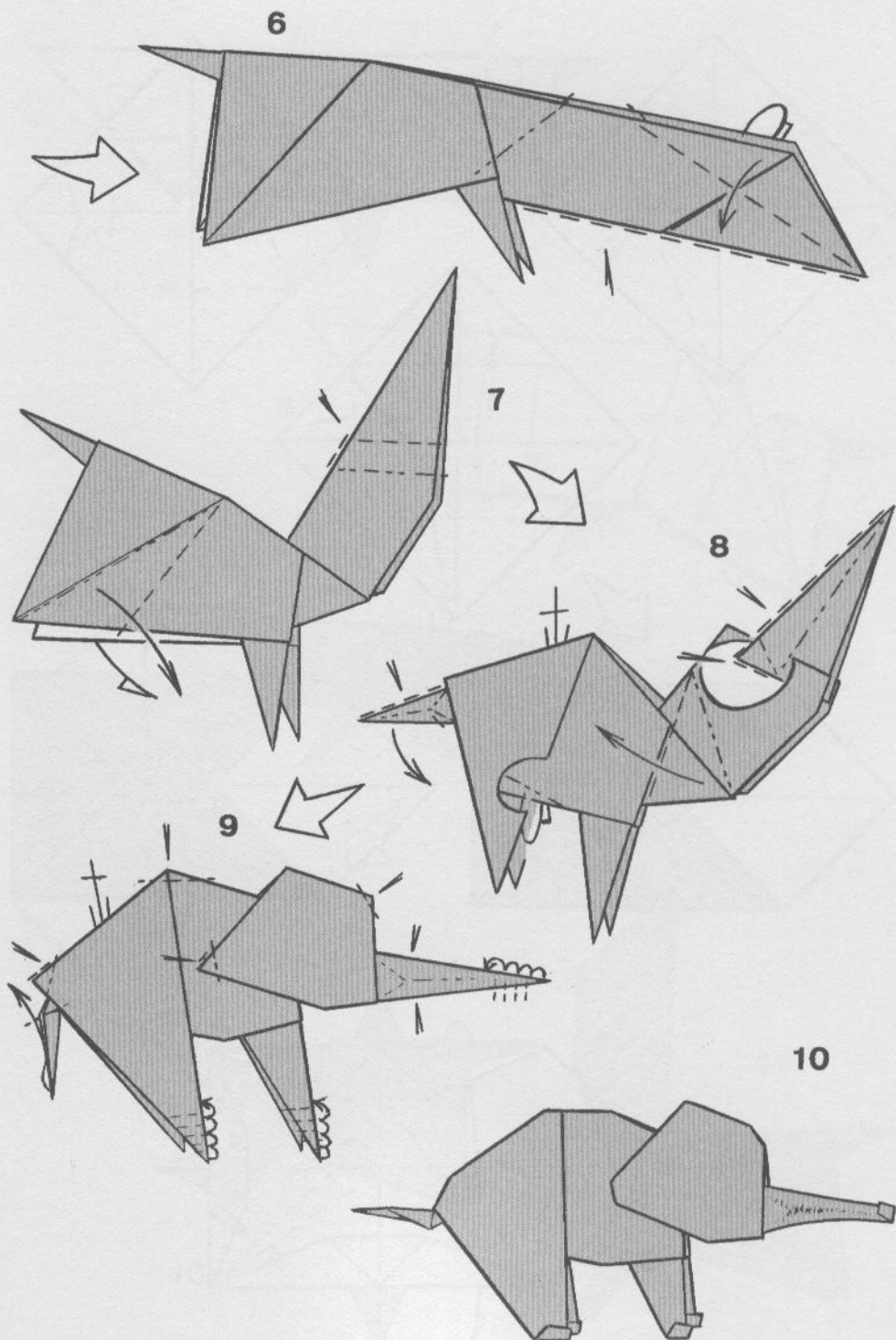

BEAR CUB

by Juan López Figueroa

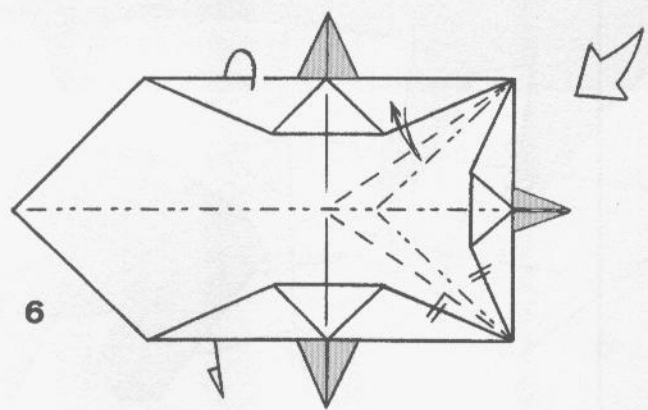
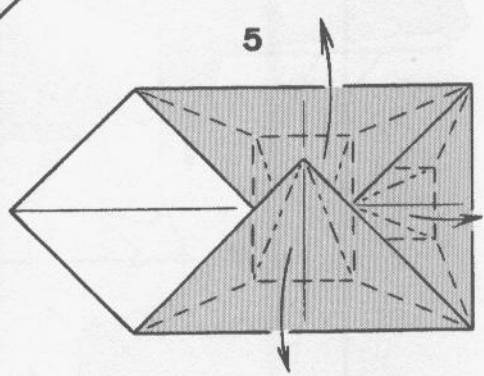
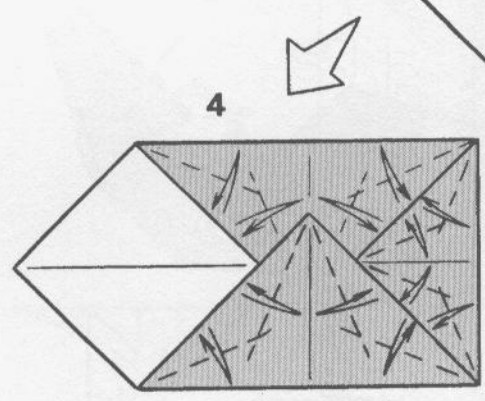
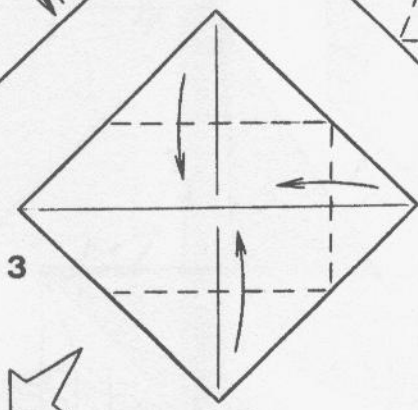
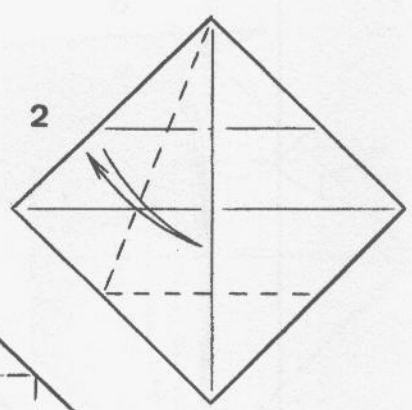
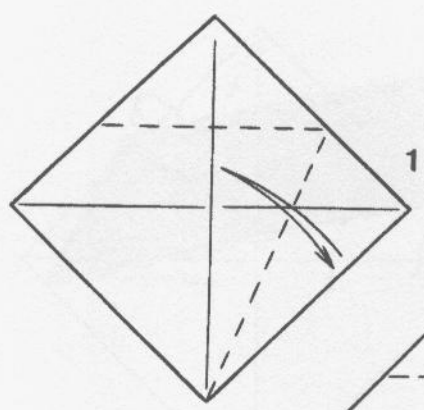

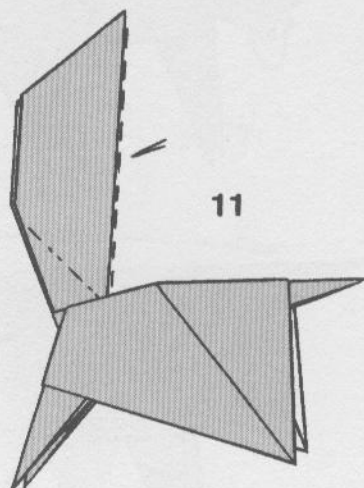
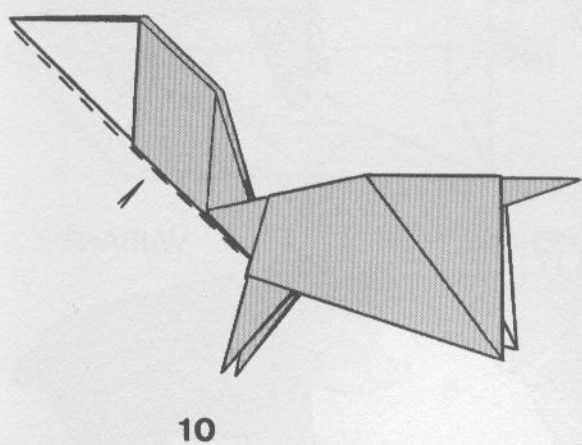
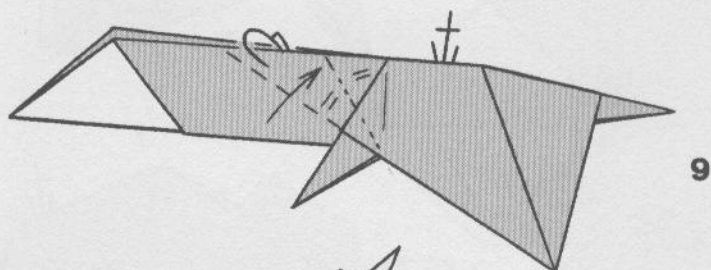
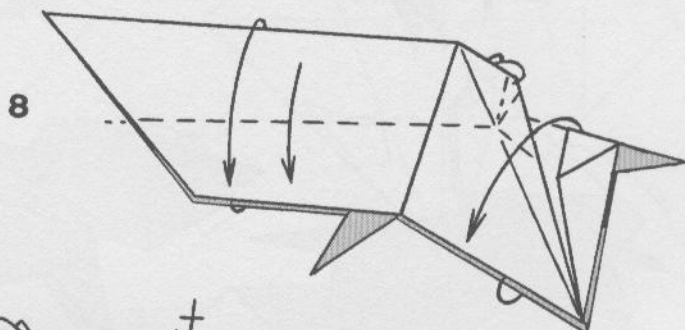
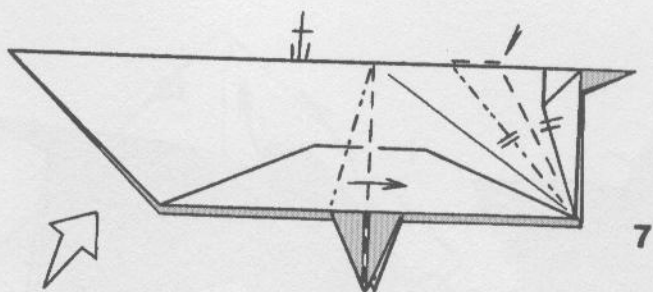

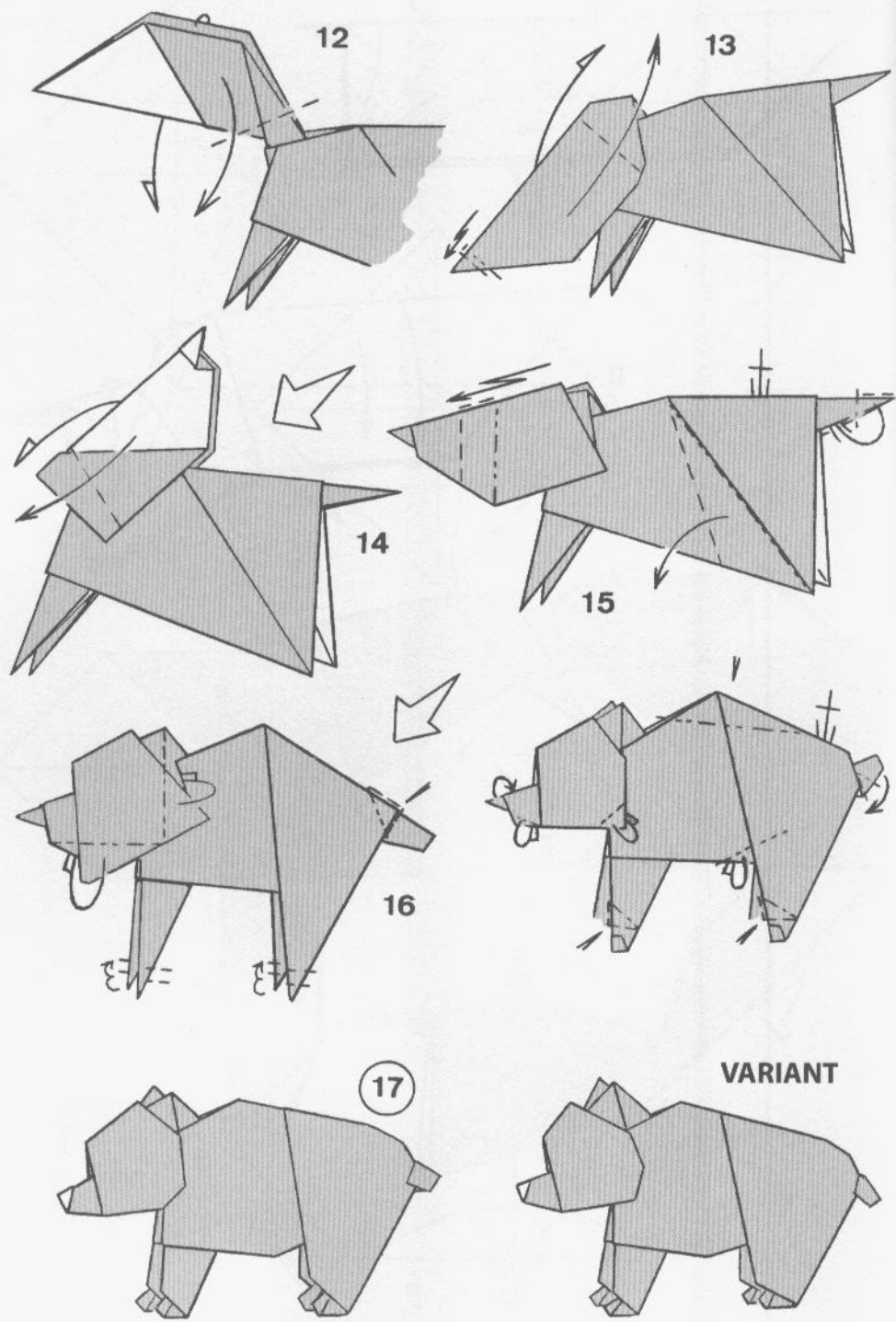

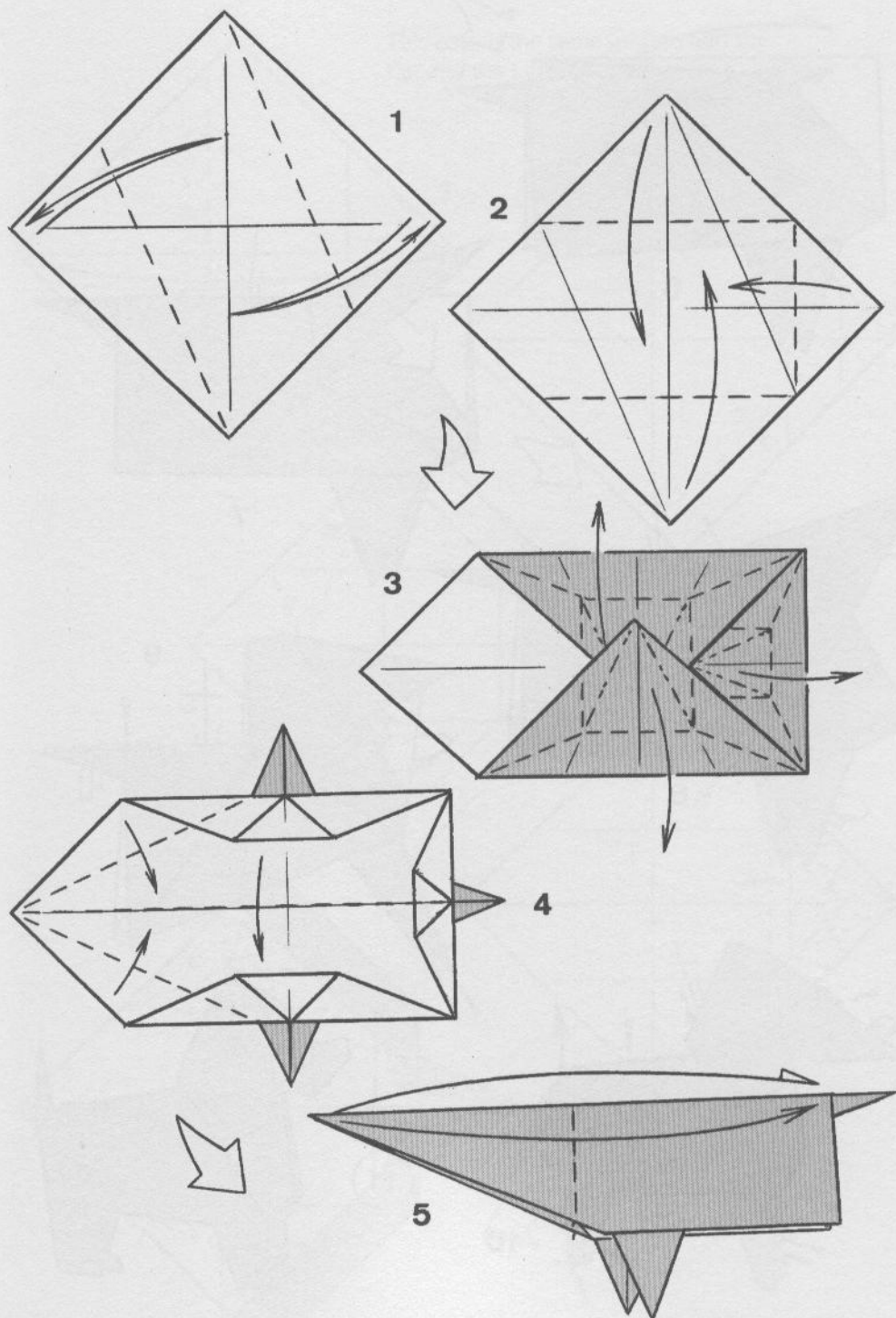

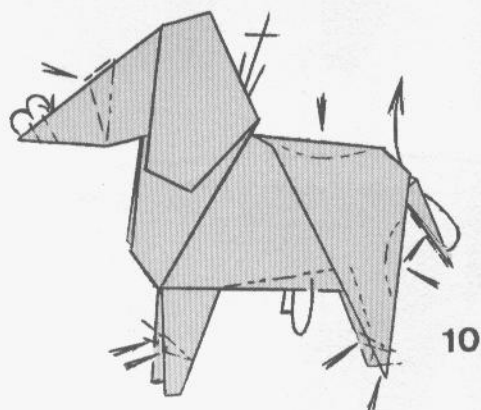
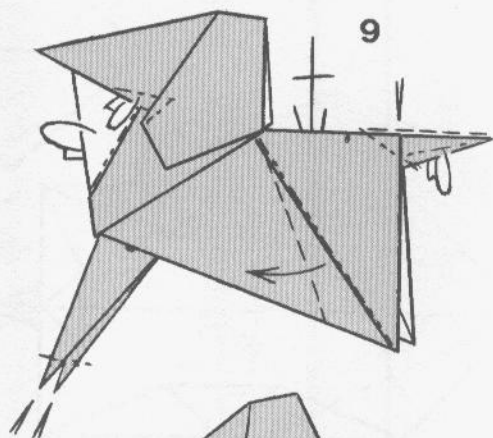
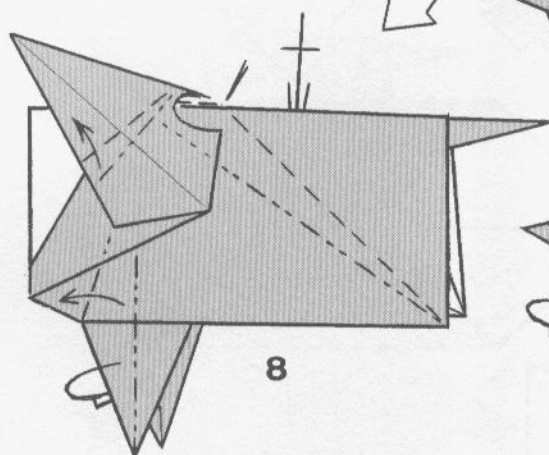
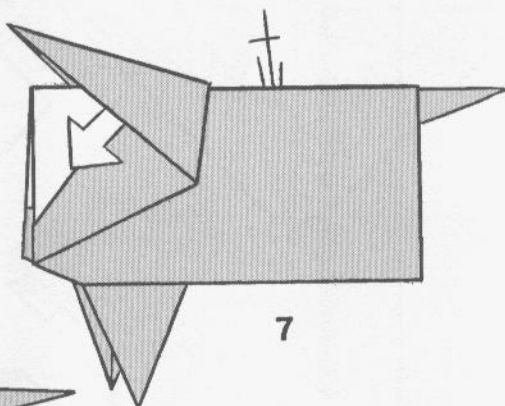
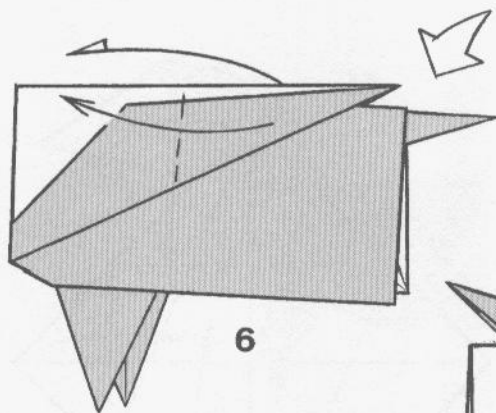

11

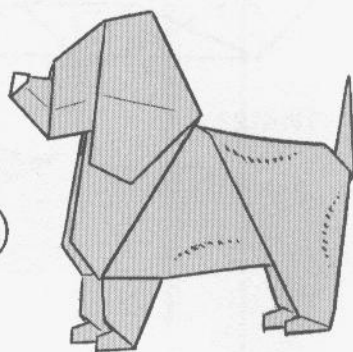

This base is the same used to fold the Cat and the Little Fox by the same creator.

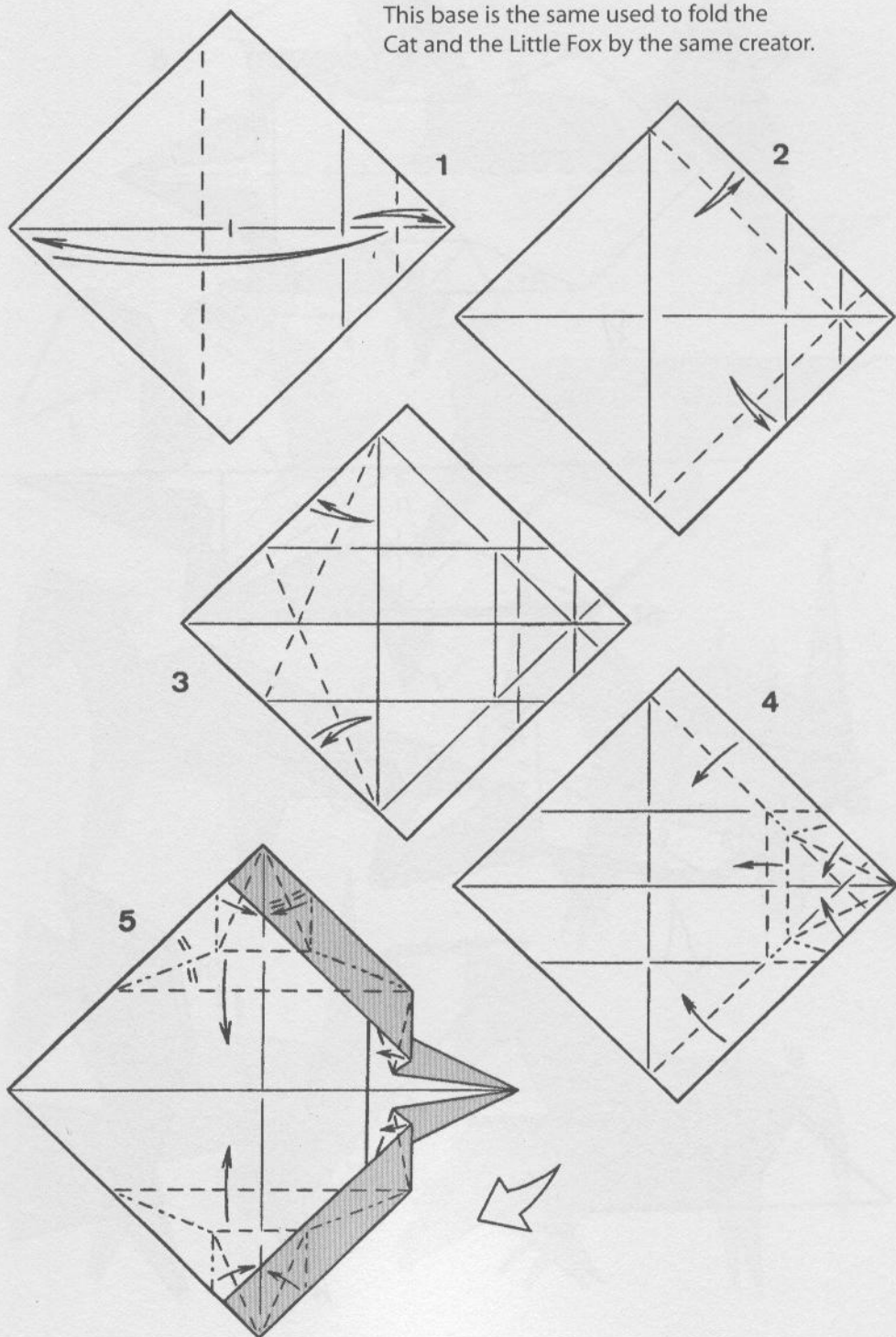

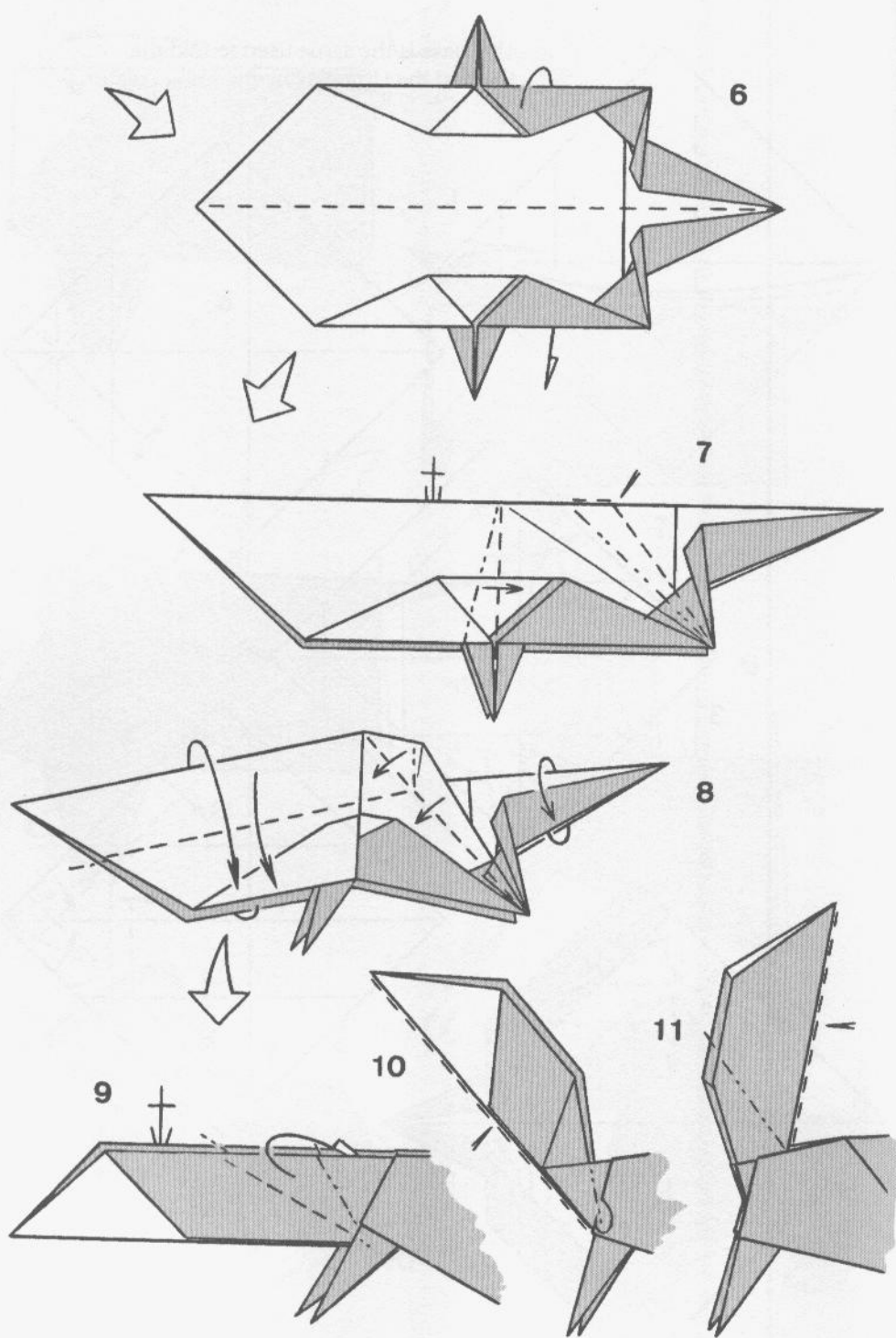

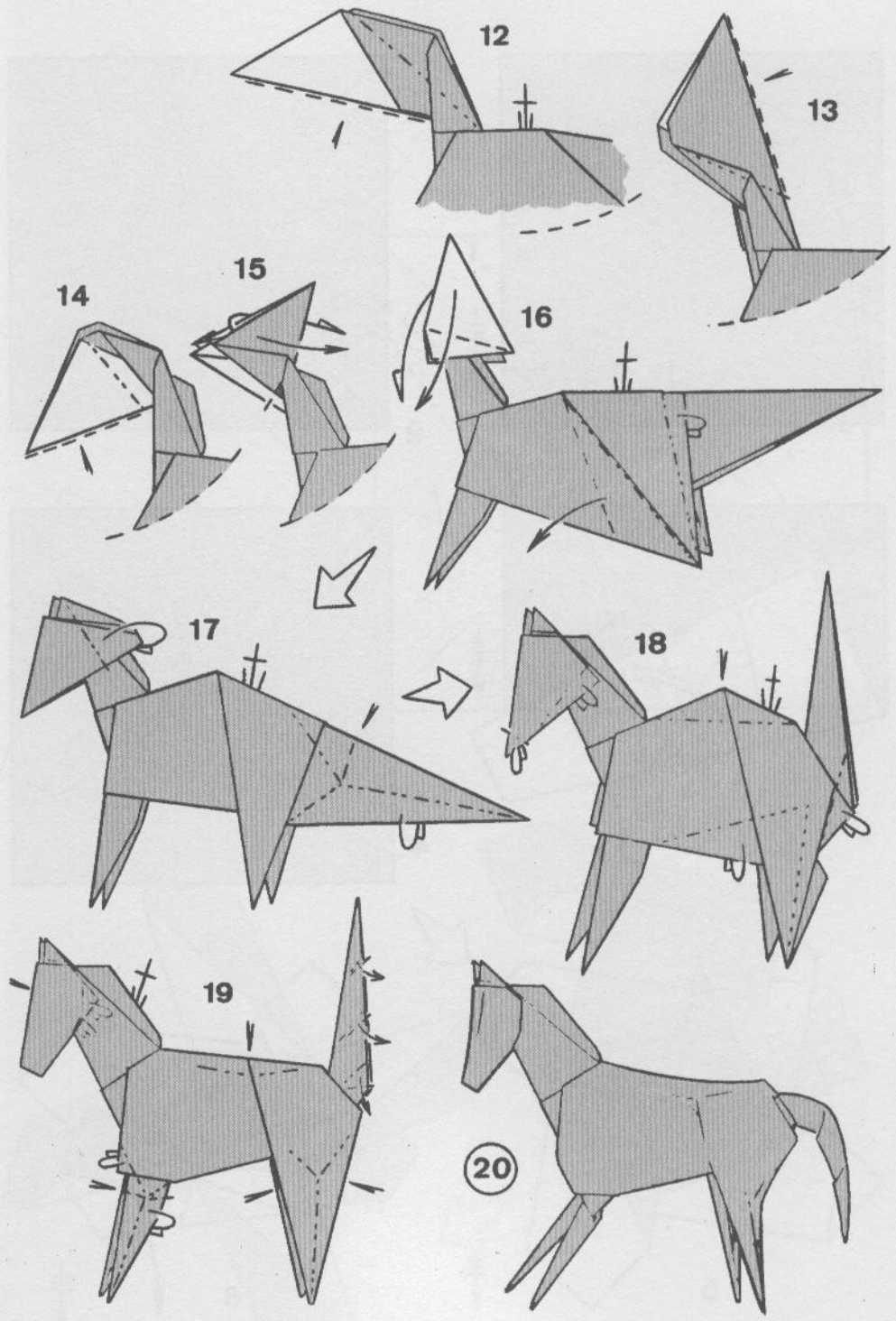

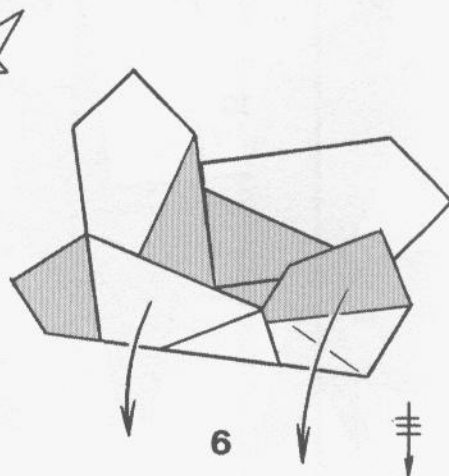
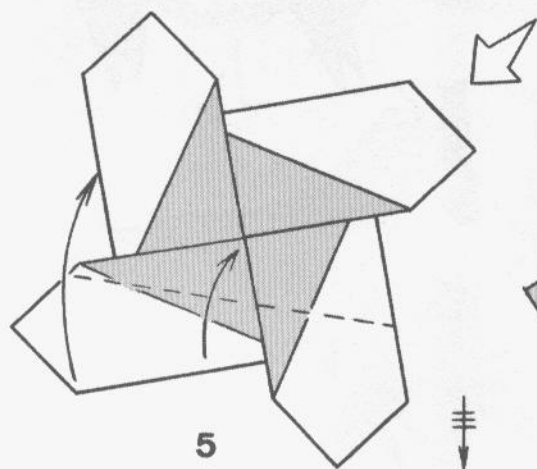
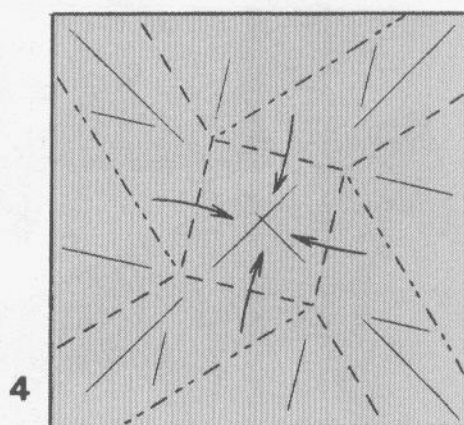
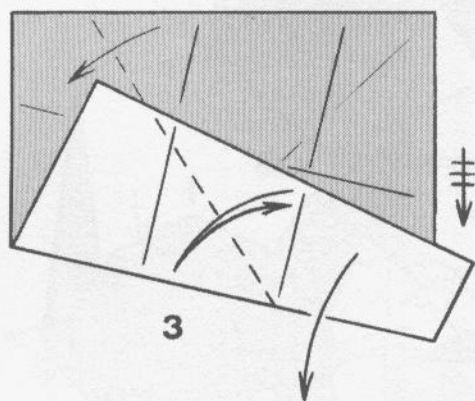
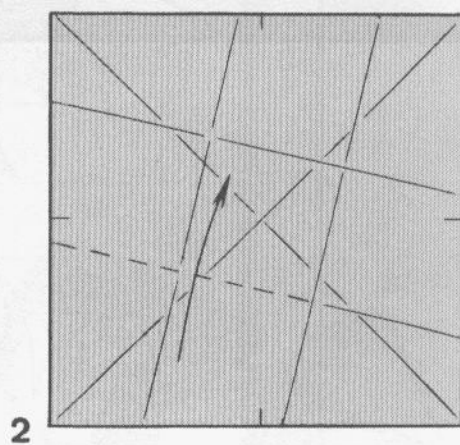
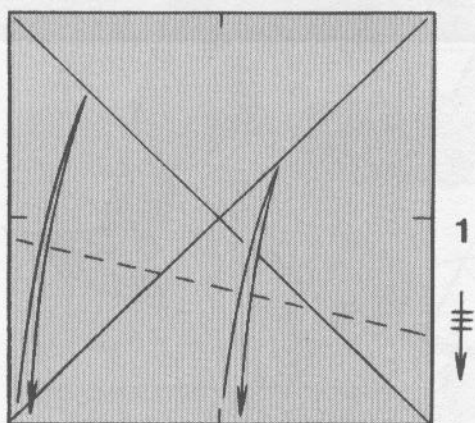

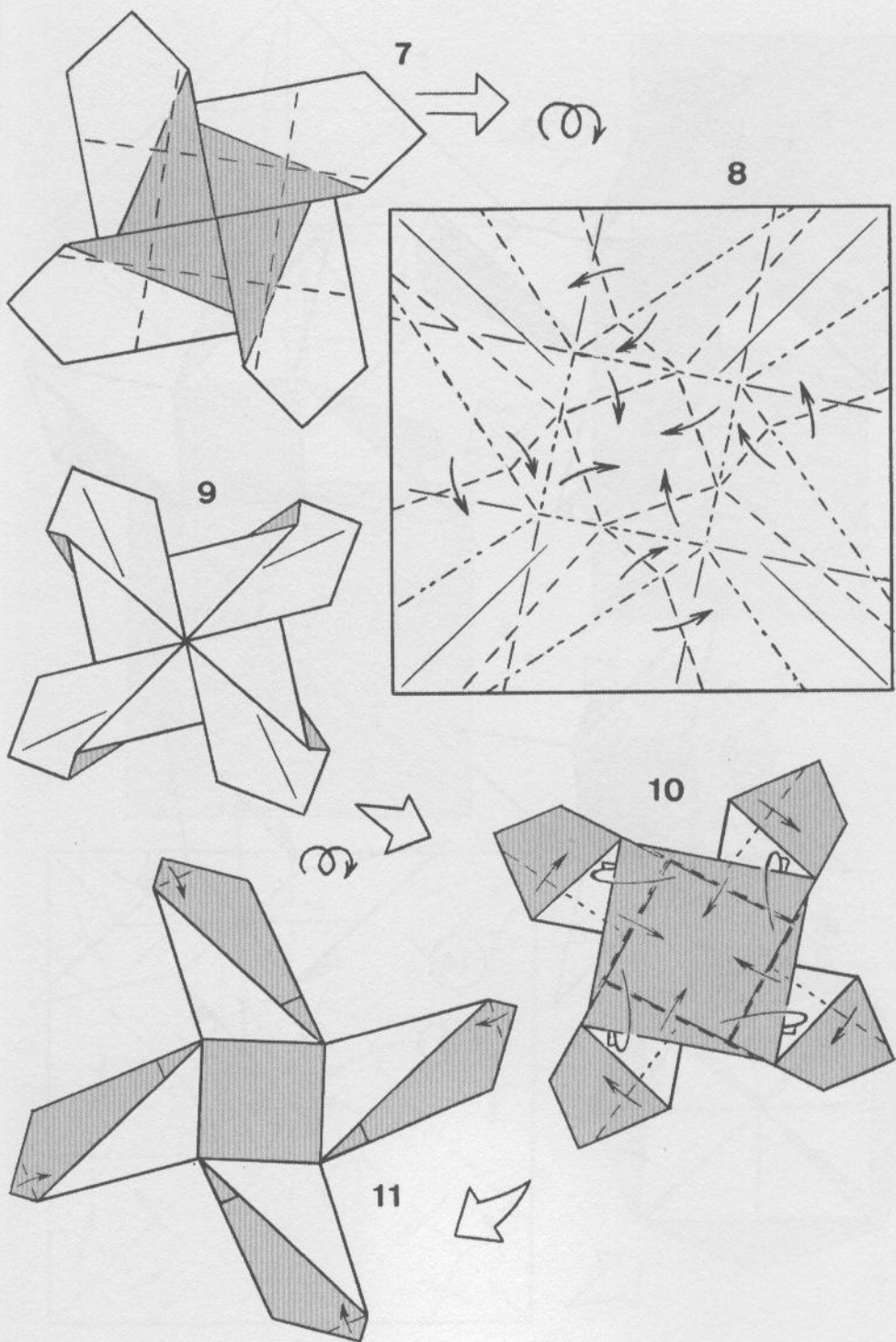

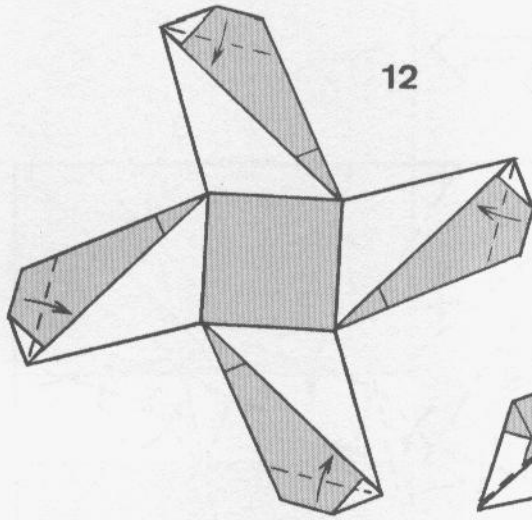

12

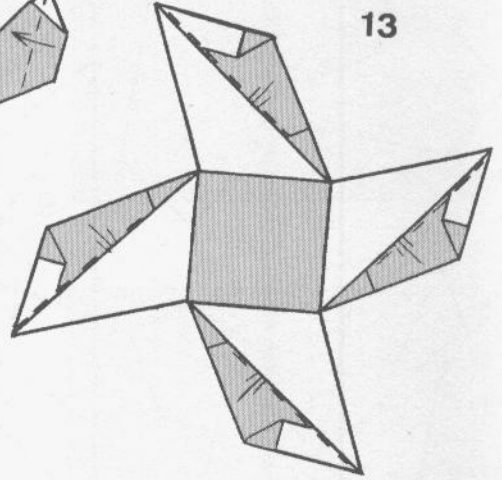

13

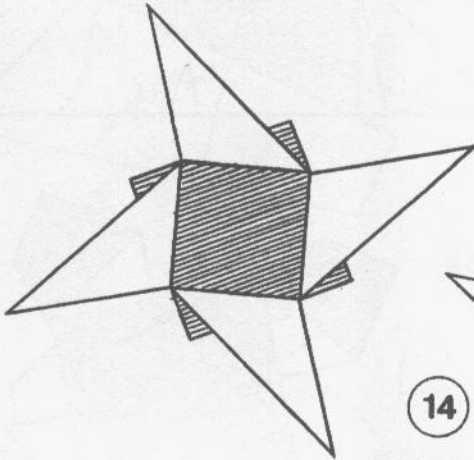

14

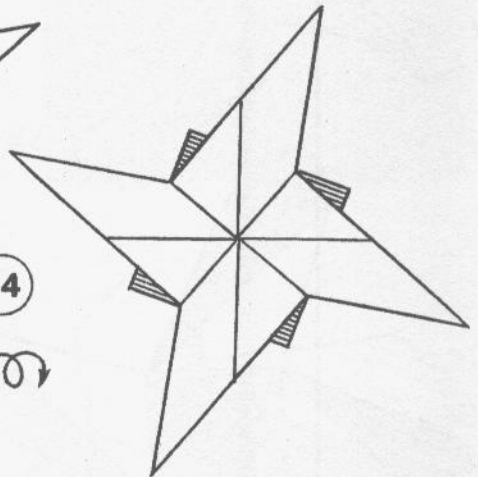

WATERWHEEL

by Fred Rohm

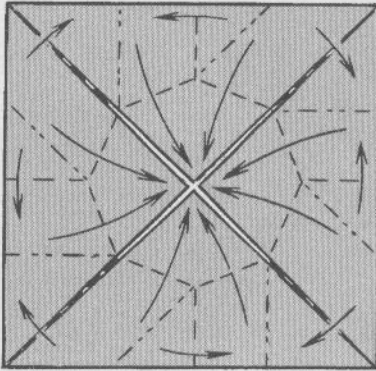
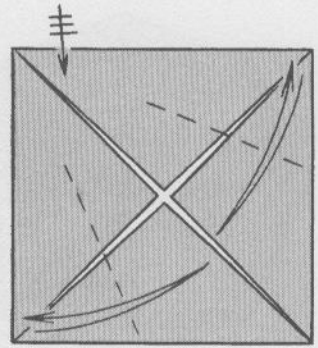
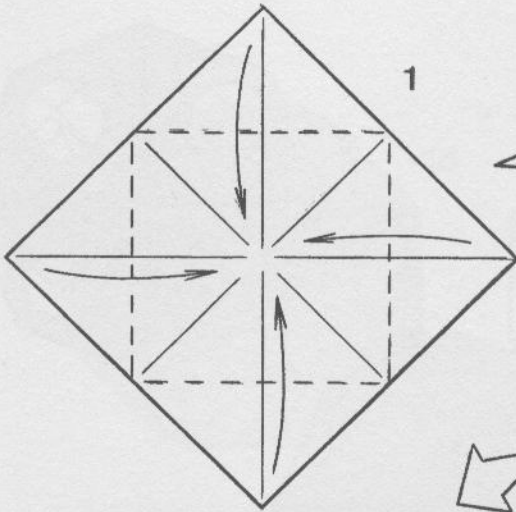

3

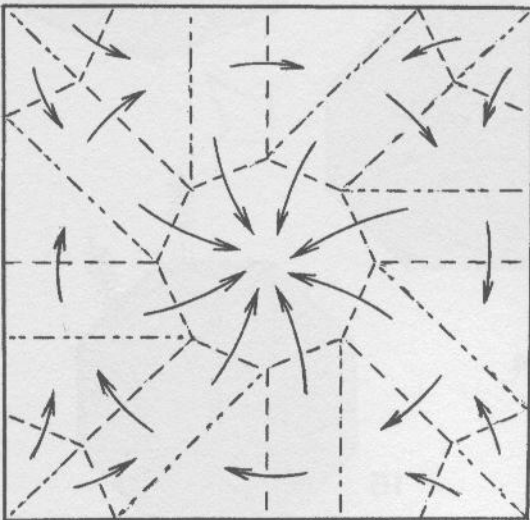
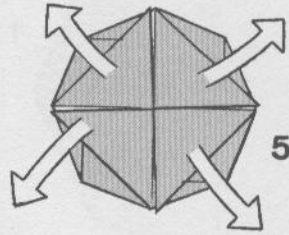
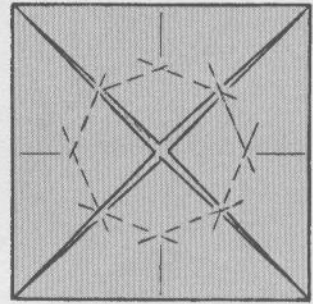

6

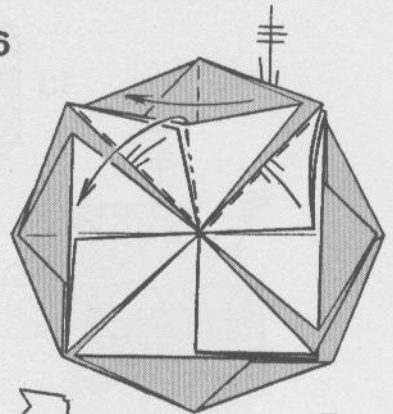

7

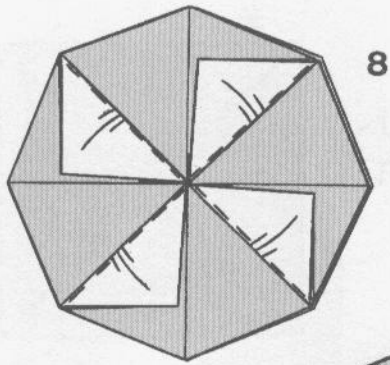

8

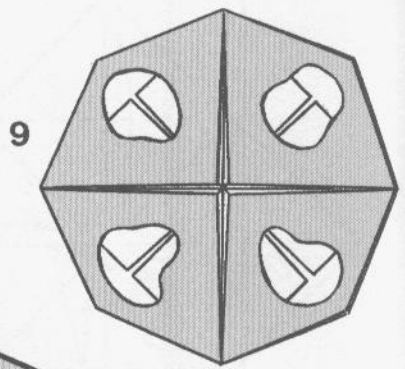

9

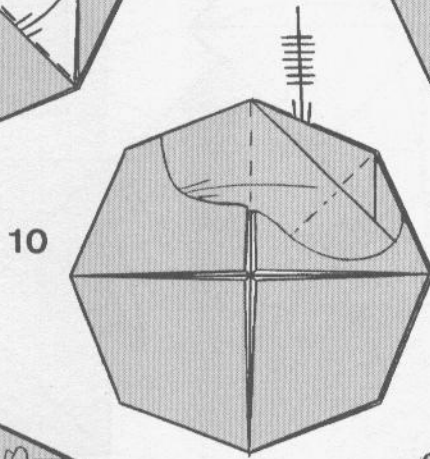

10

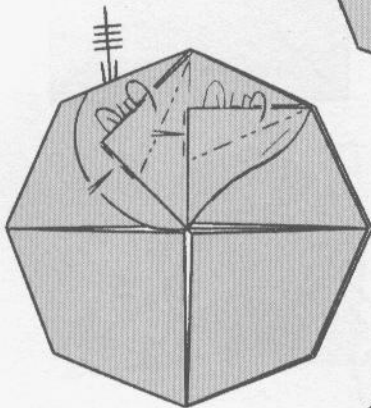

11

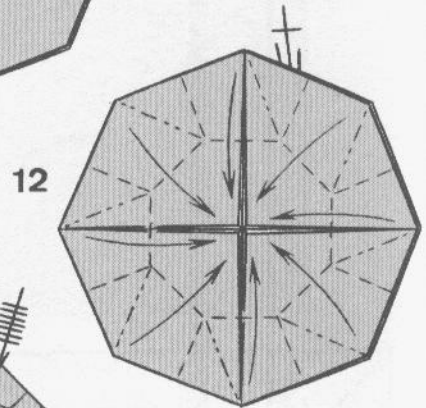

12

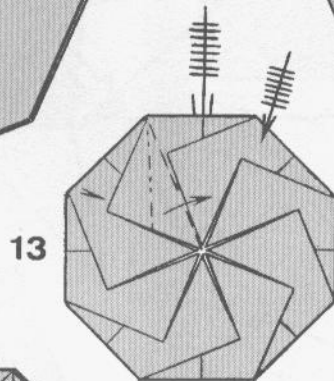

13

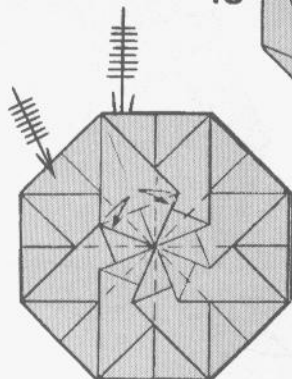

14

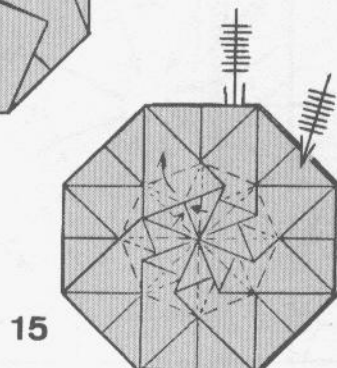

15

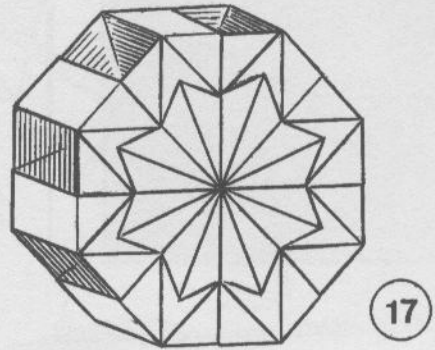
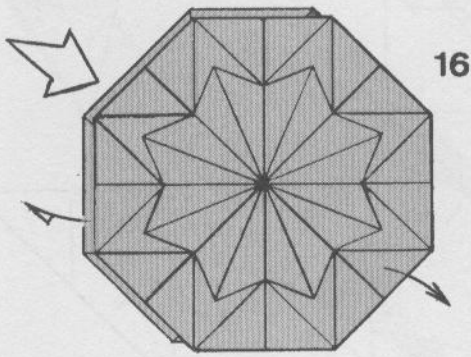

IT'S GOOD TO FOLD IT WITH PAPER THAT HAS METALLIC FOIL ON ONE SIDE.

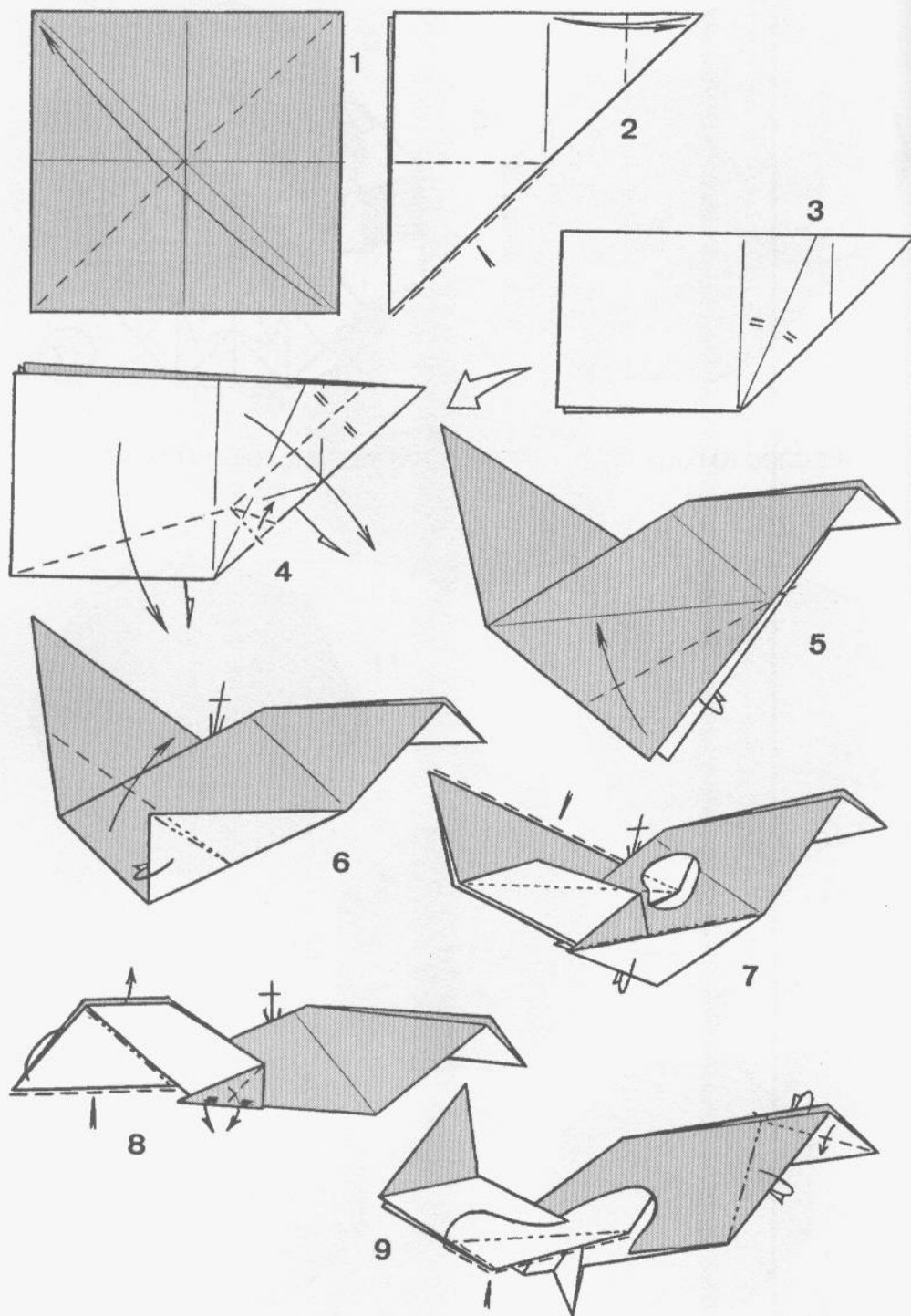

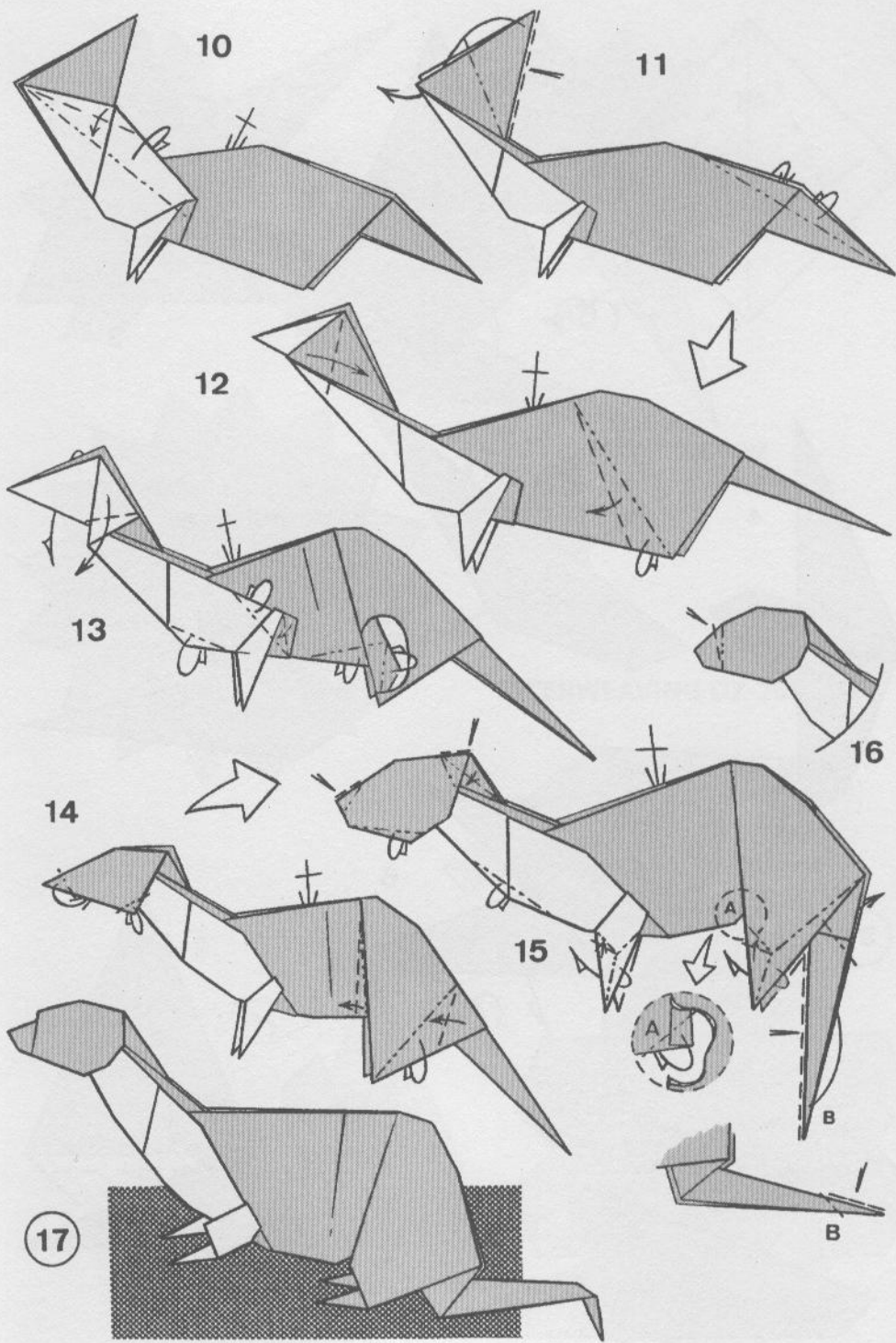

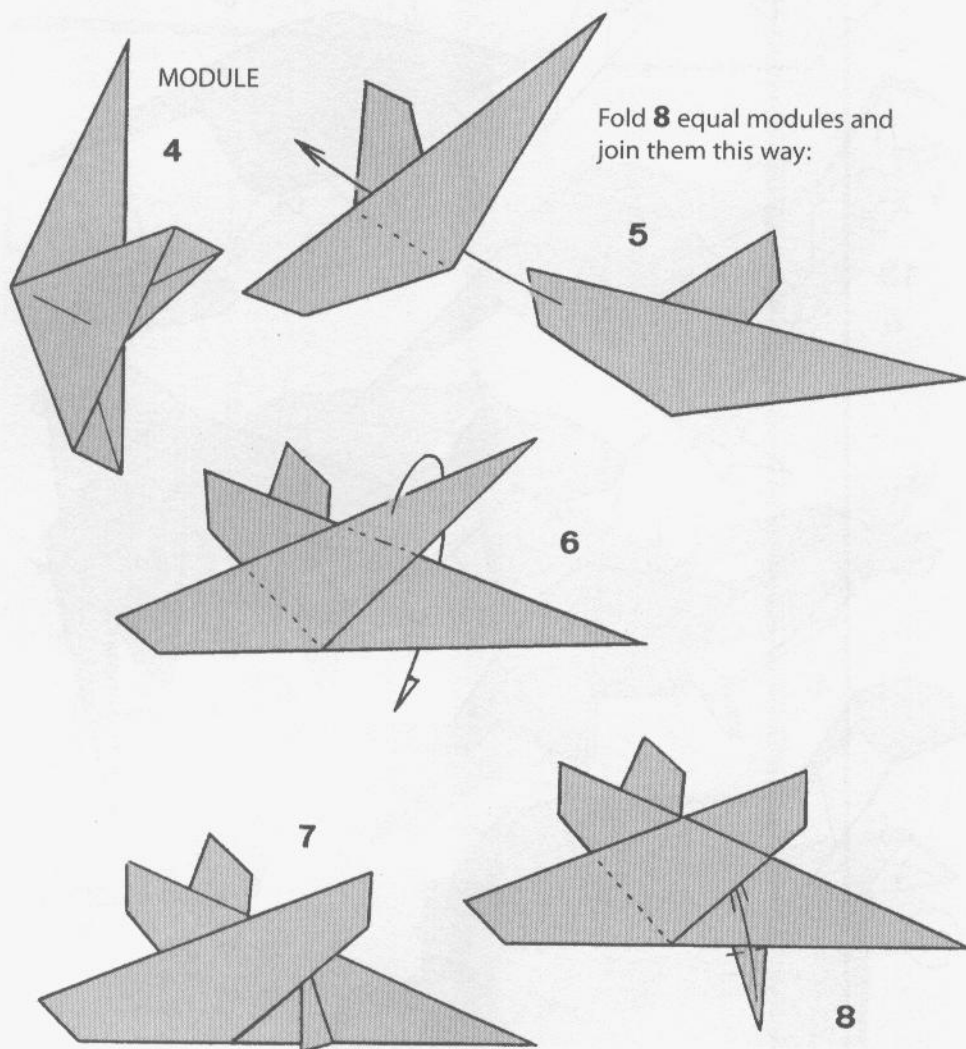
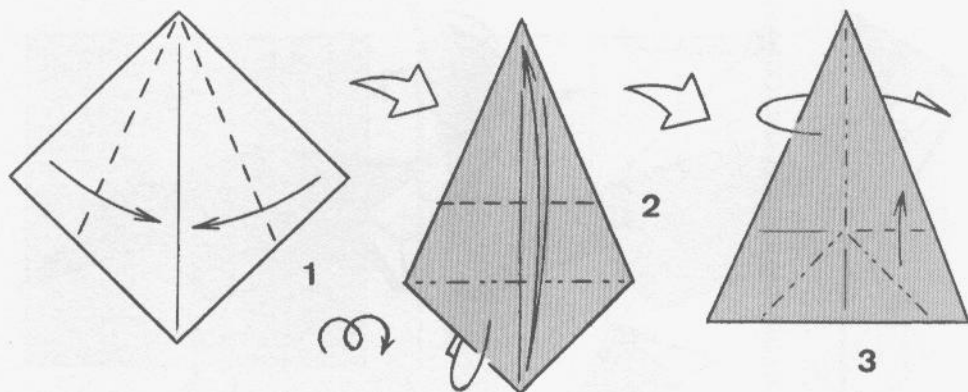

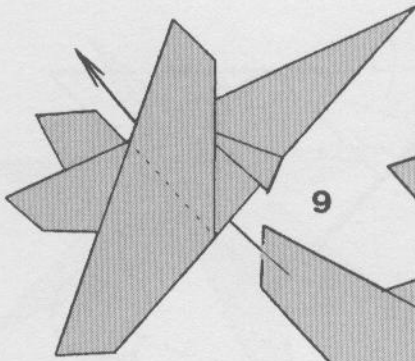

9

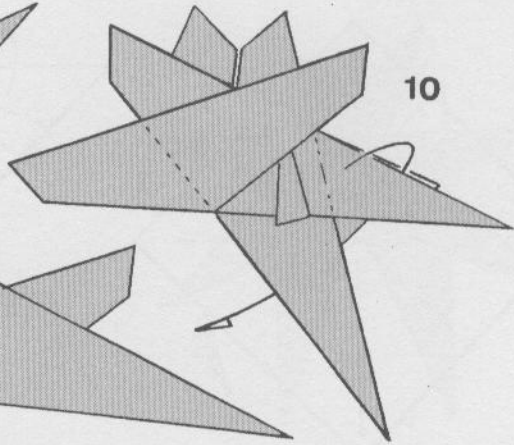

10

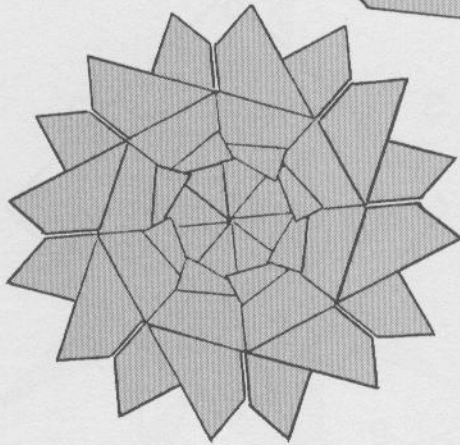

11

INTERWEAVING DZ-20B

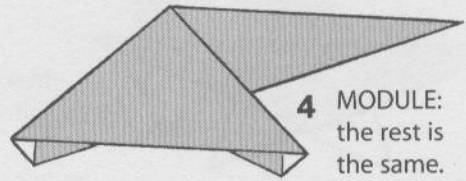

4 MODULE:
the rest is
the same.

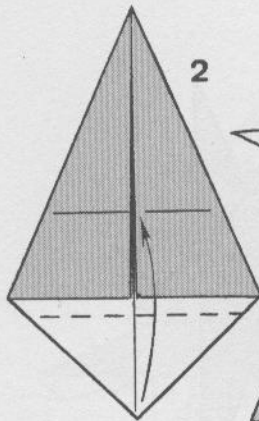

2

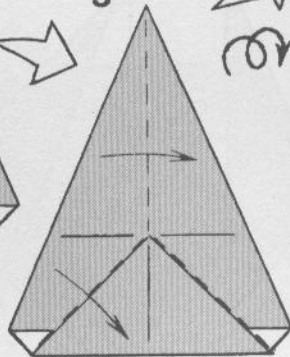

3

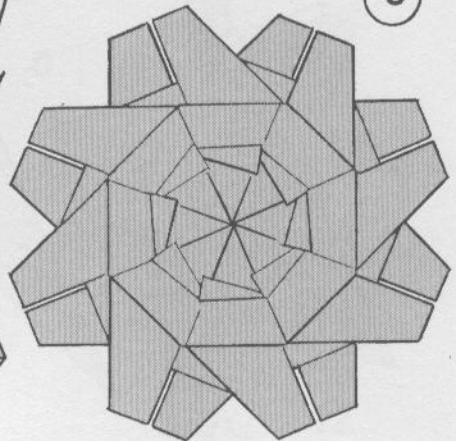
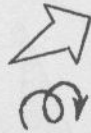

5

EIGHT-MODULE STAR 2

by Jeff Beynon

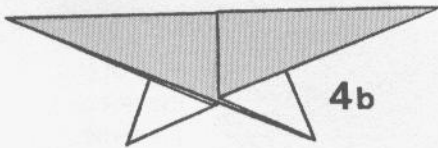
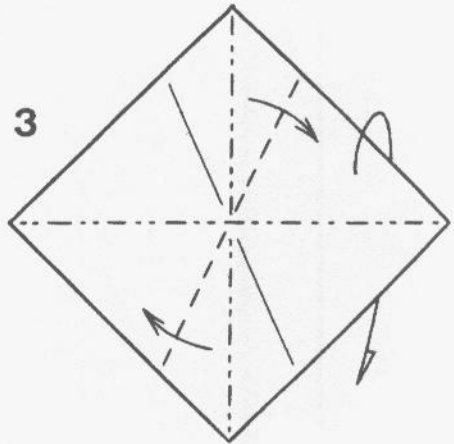
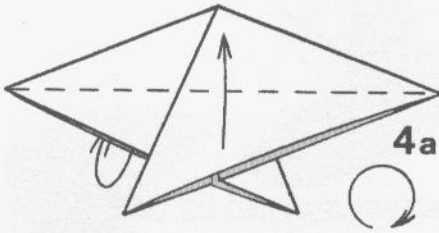
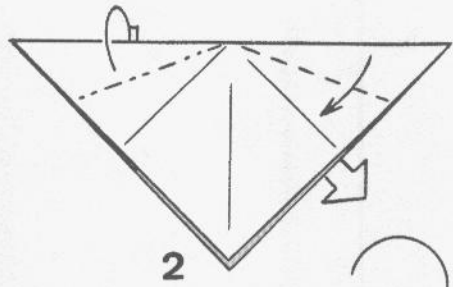
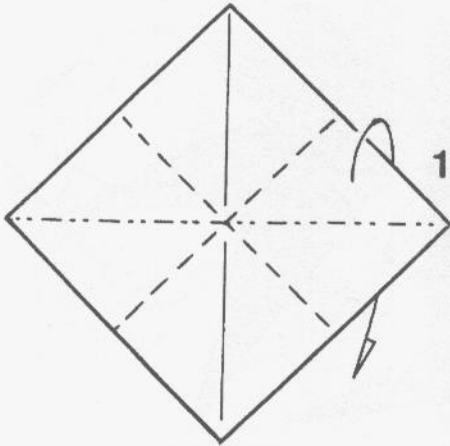

Make **8** equal modules and join them this way:

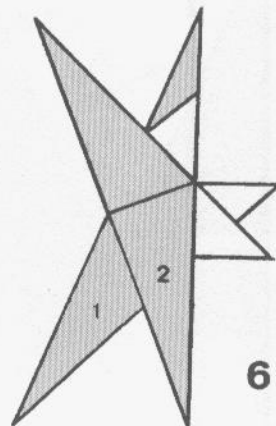
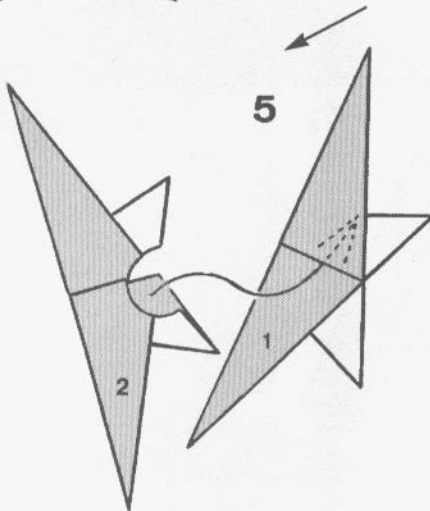

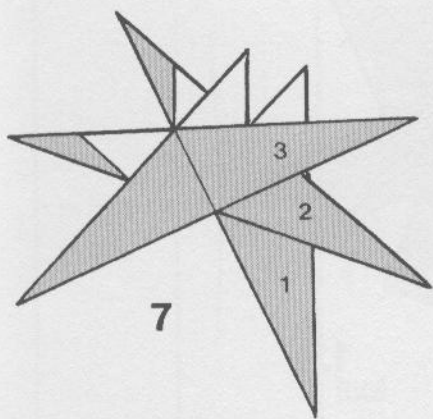

7

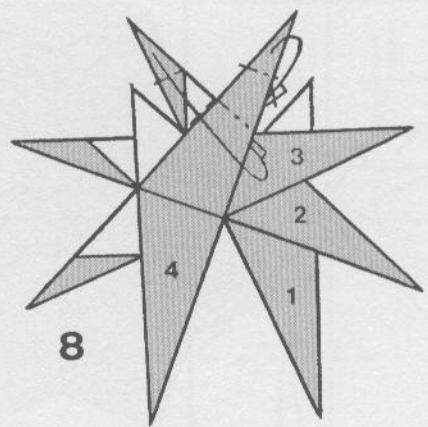

8

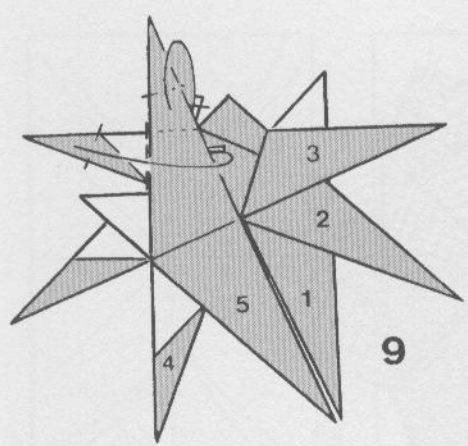

9

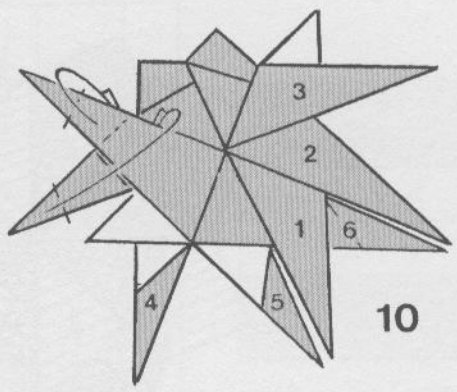

10

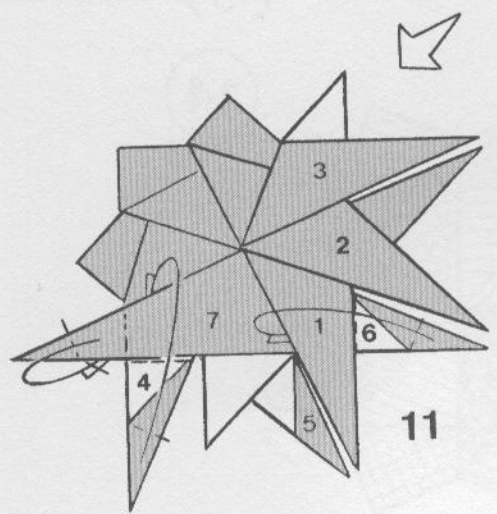

11

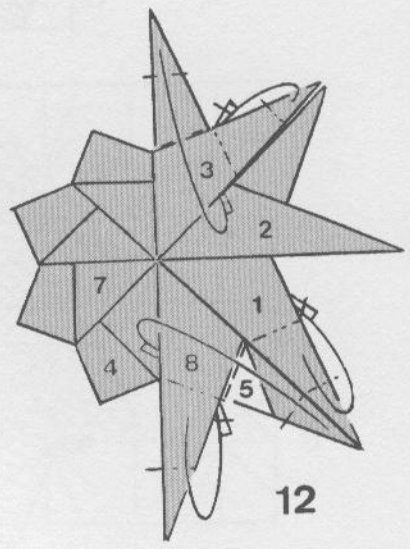

12

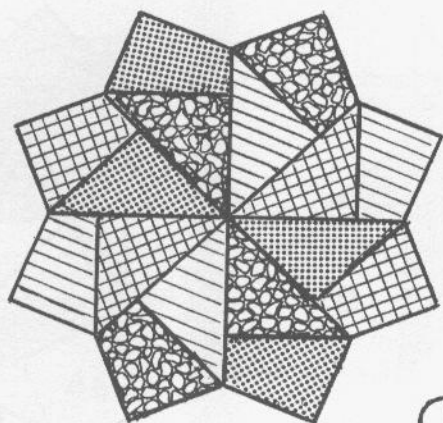
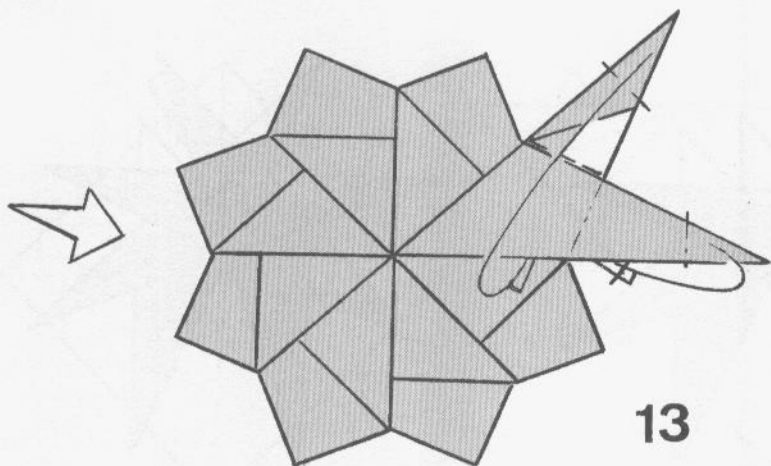

14

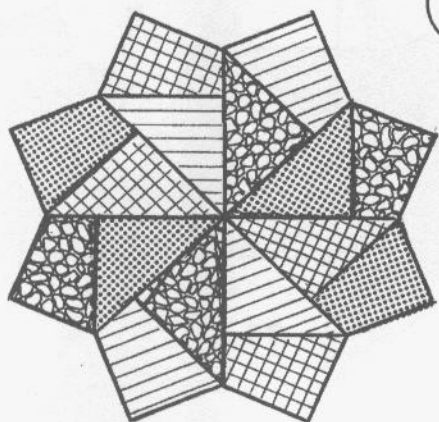

BOWL OR OPEN RECEPTACLE

by Dr. Philip Shen

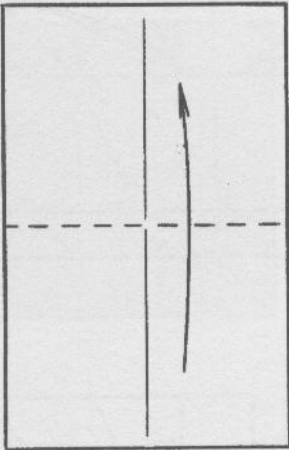

8x5

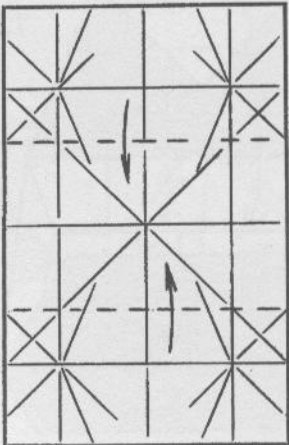
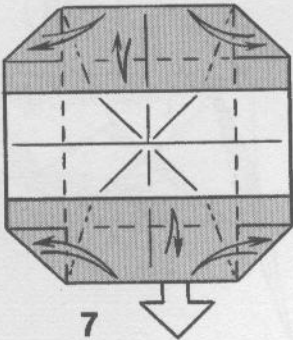
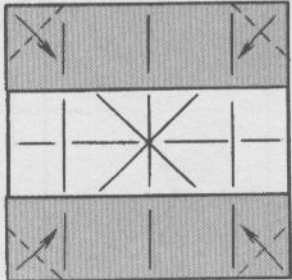
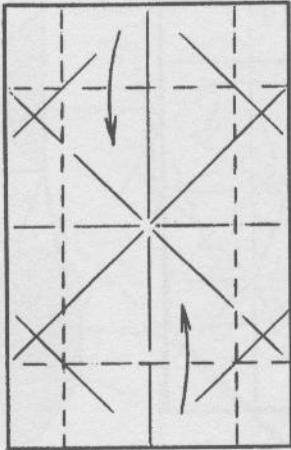
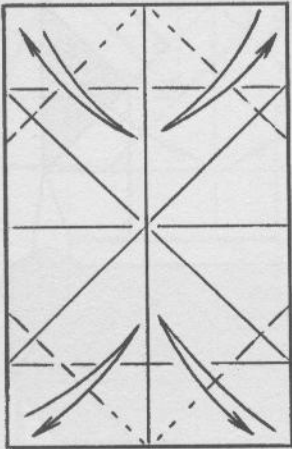
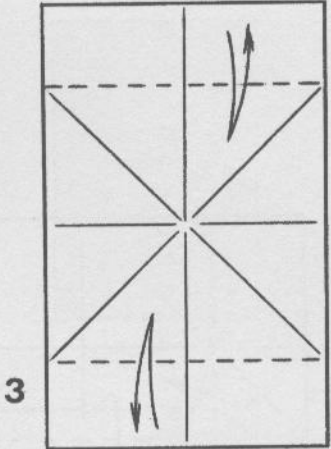
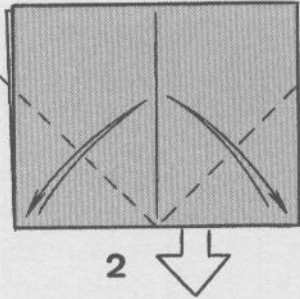

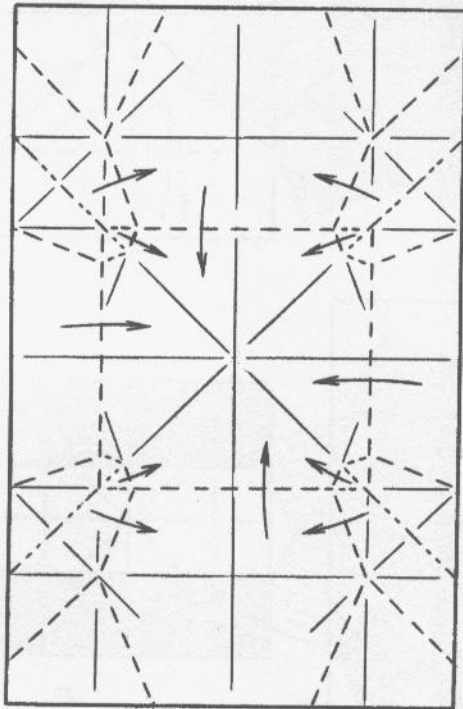

9

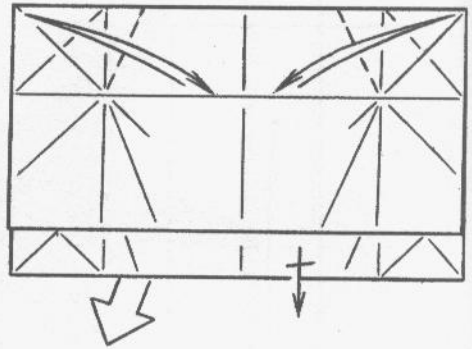

10

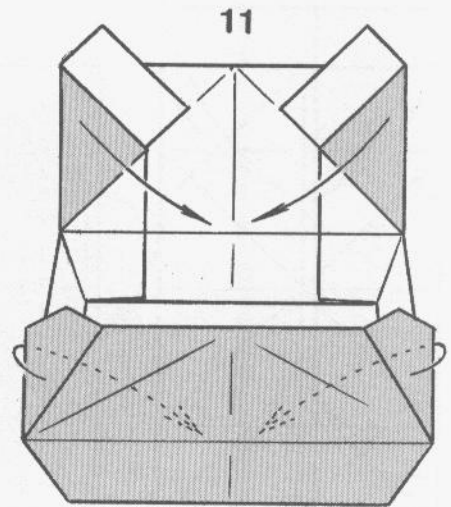

11

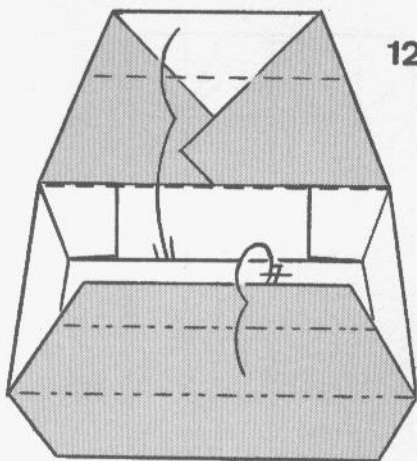

12



13

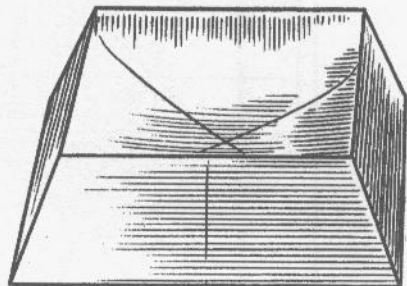

GEISHA

by José Meeusen

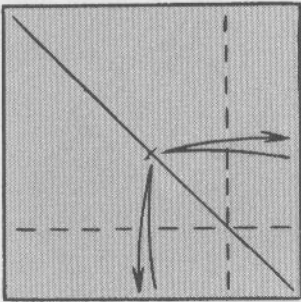

1

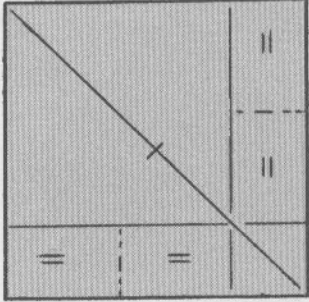

2

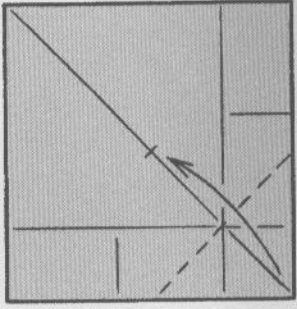

3



PREFOLDS

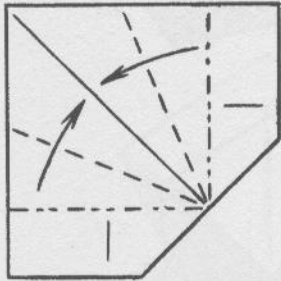

3a

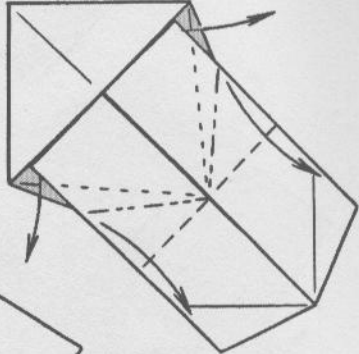

4

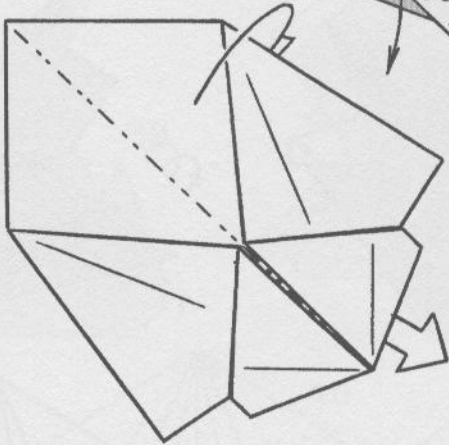

5

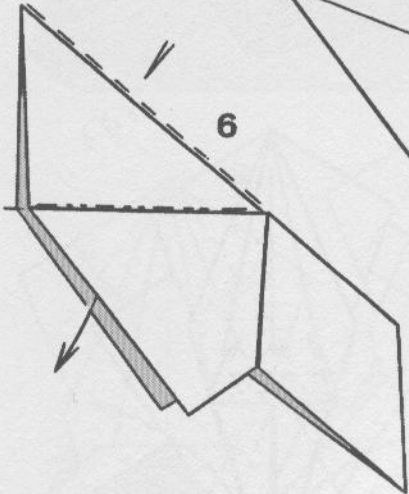

6

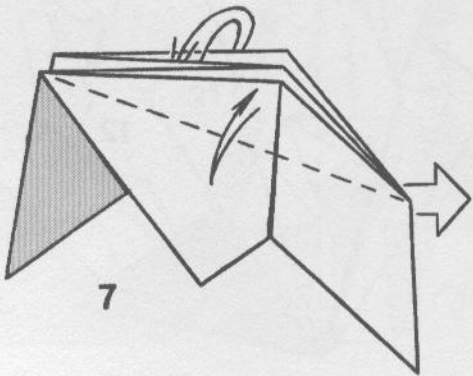

7

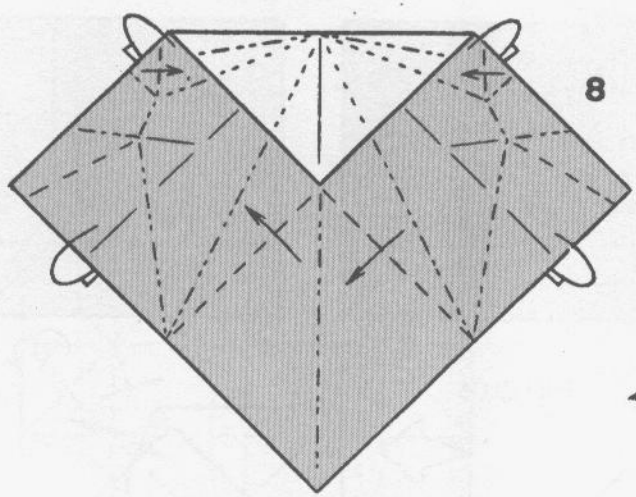

8

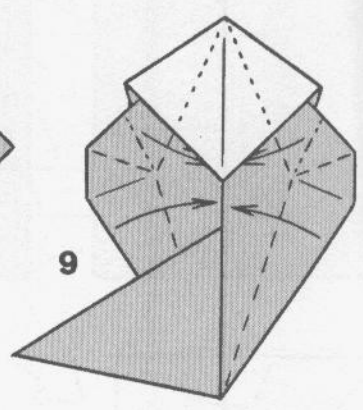

9

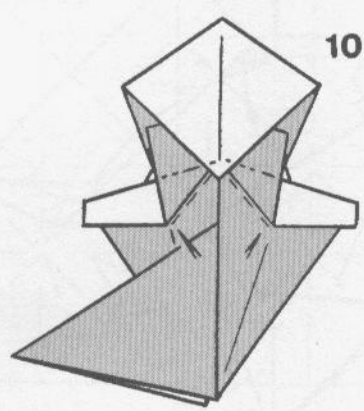

10

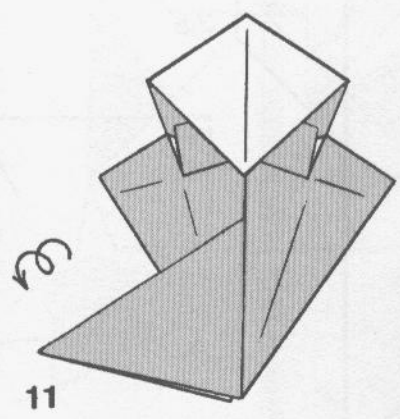

11

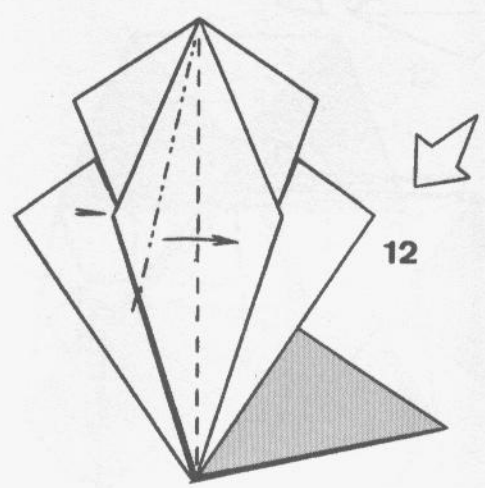

12

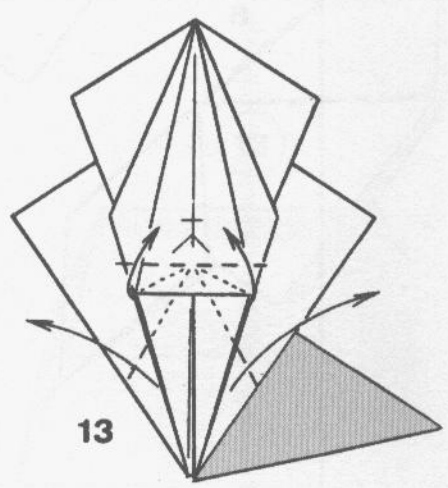

13

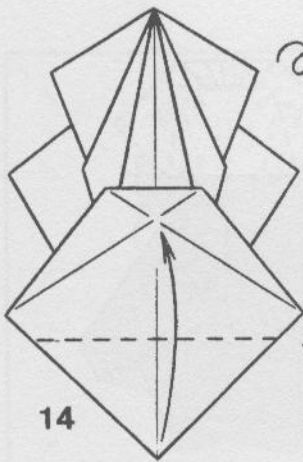

14

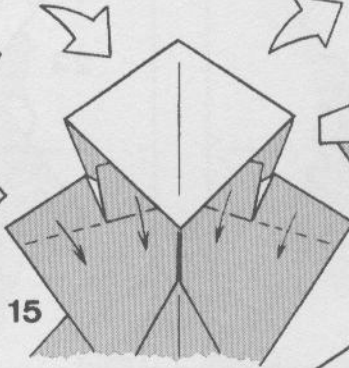

15

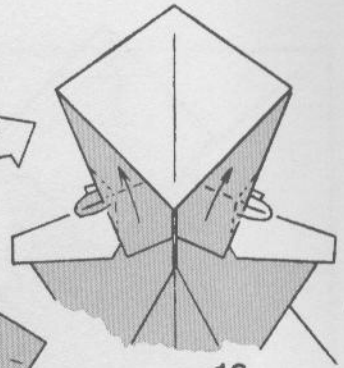

16

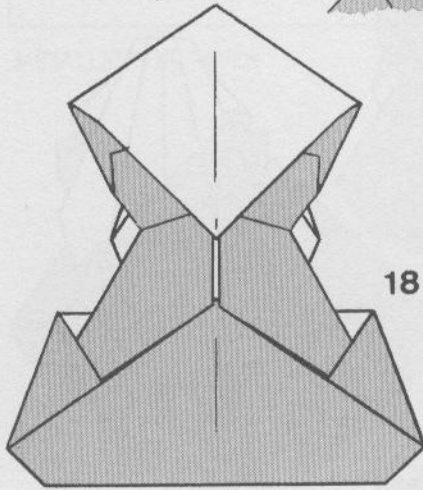

18

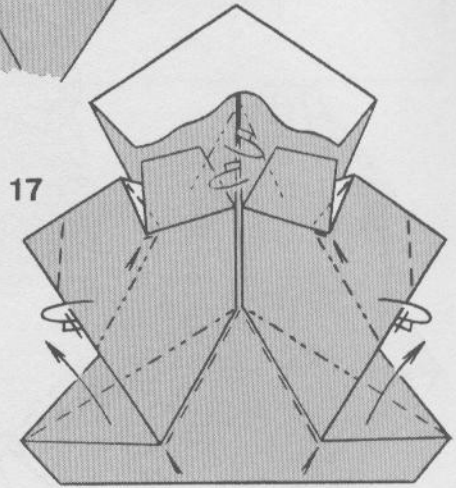

17



19

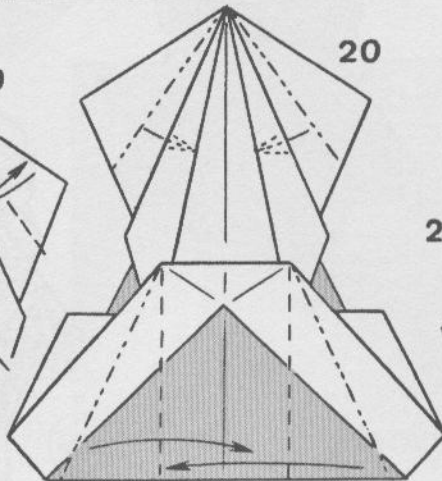

20

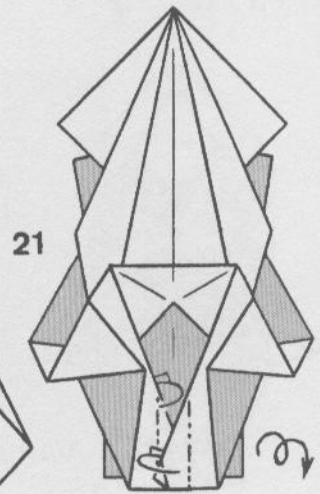

21

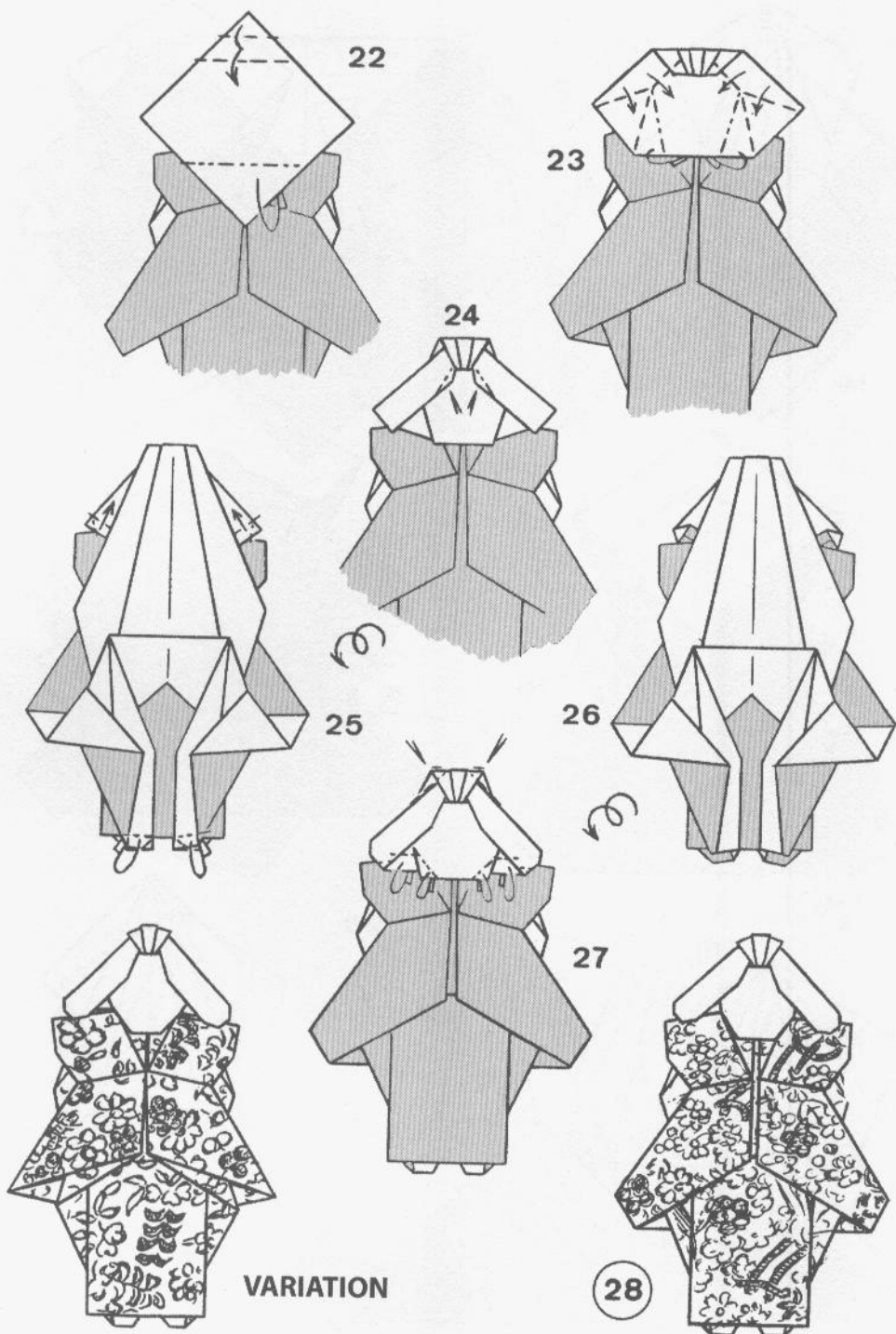

BIPLANE

by Yoshihide Momotani

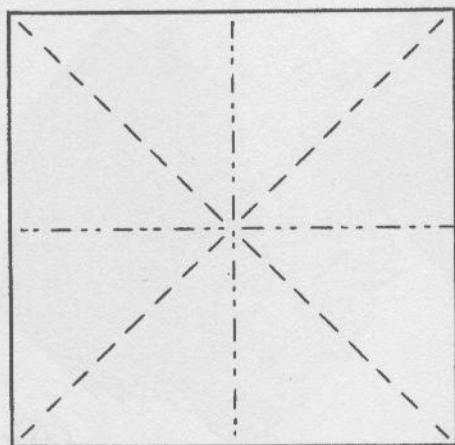

METALLIC-FOIL PAPER

1

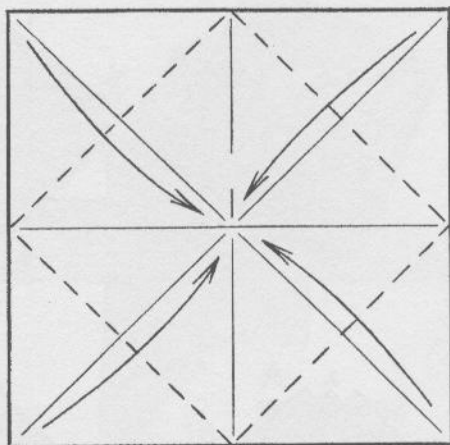

2

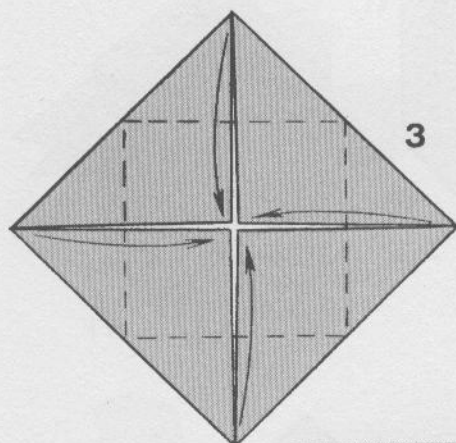

3

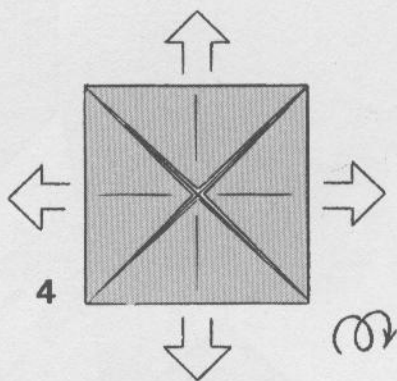

4

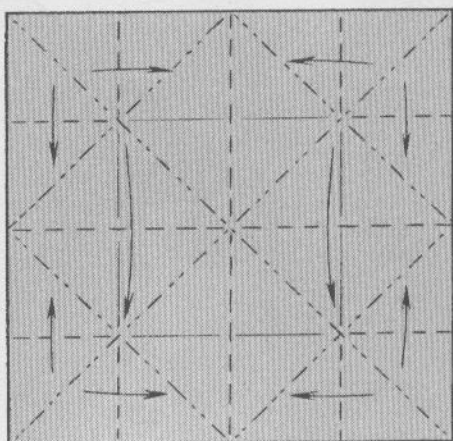

5

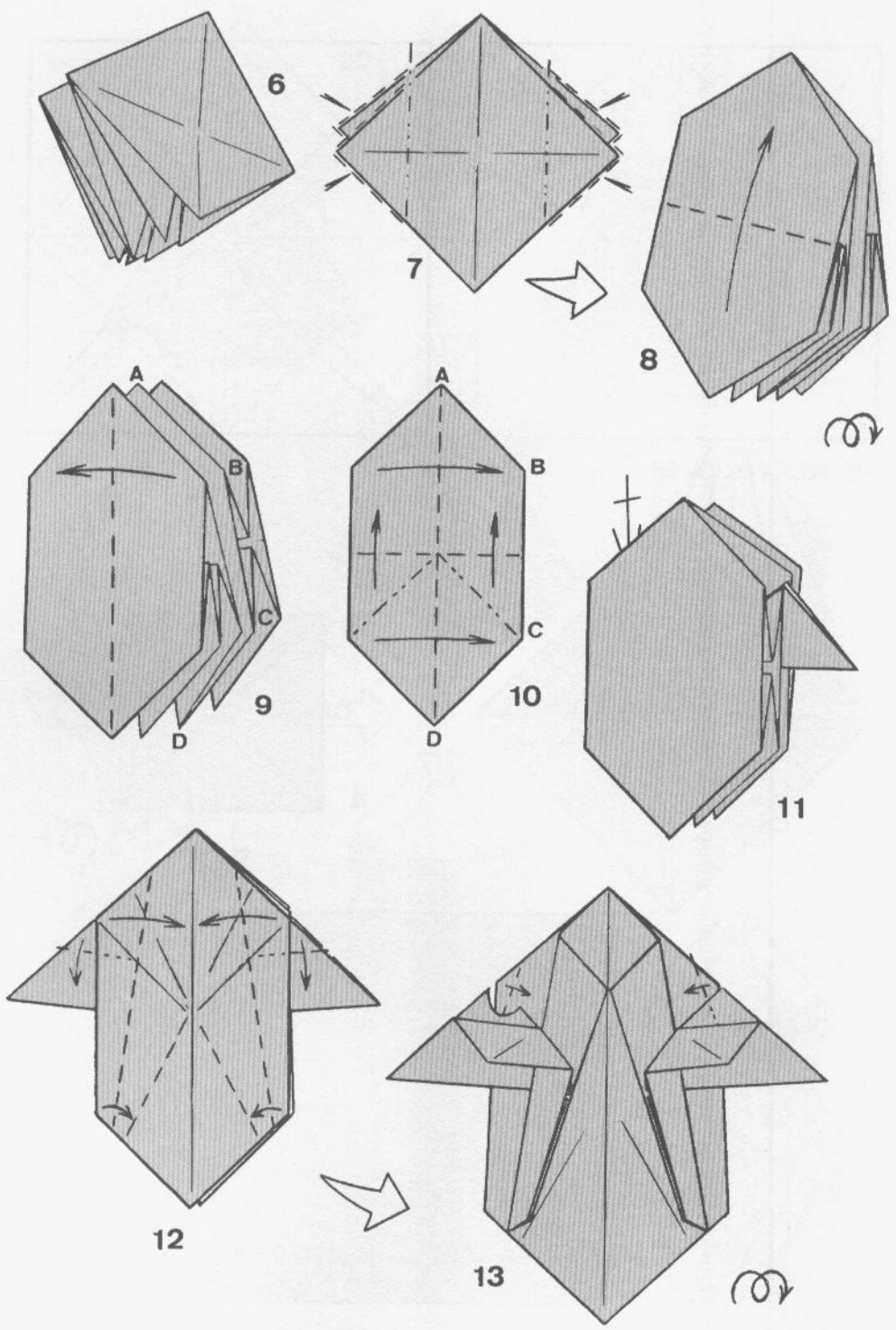

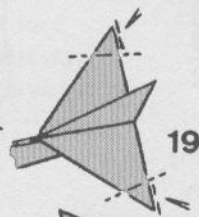
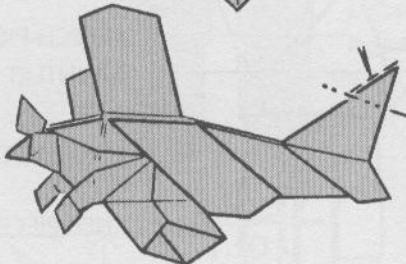
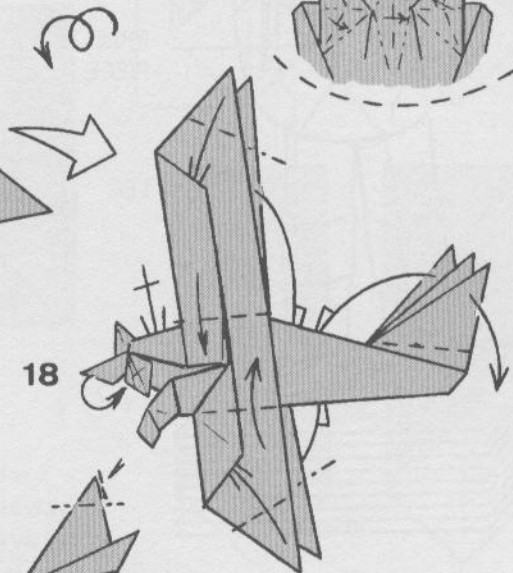
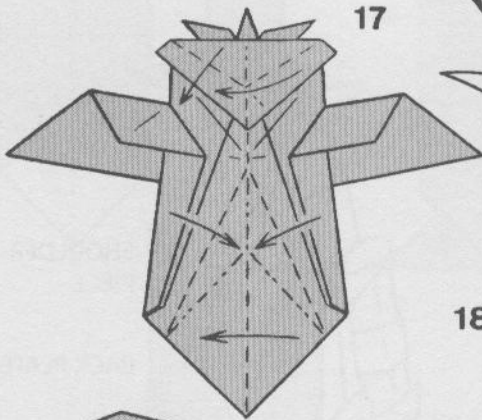
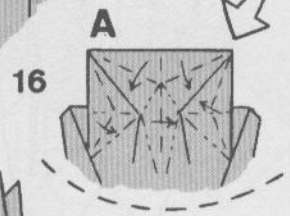
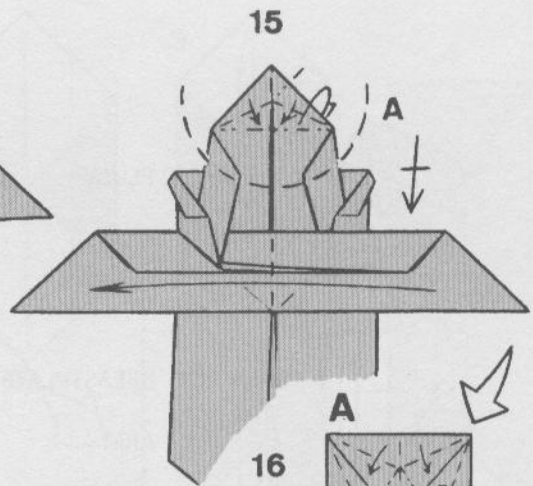
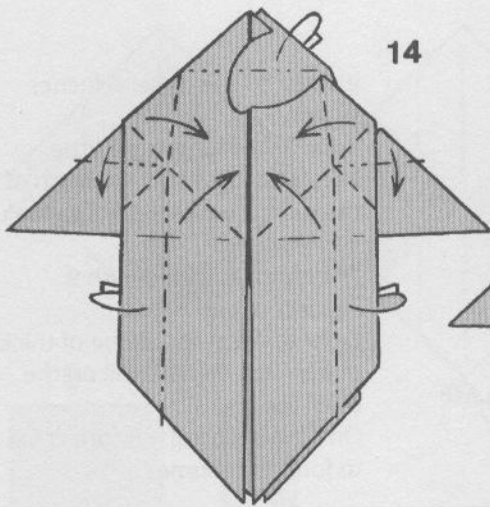

21

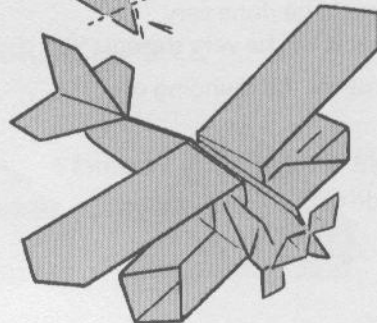

ARMOR

by Francisco Javier Caboblanco

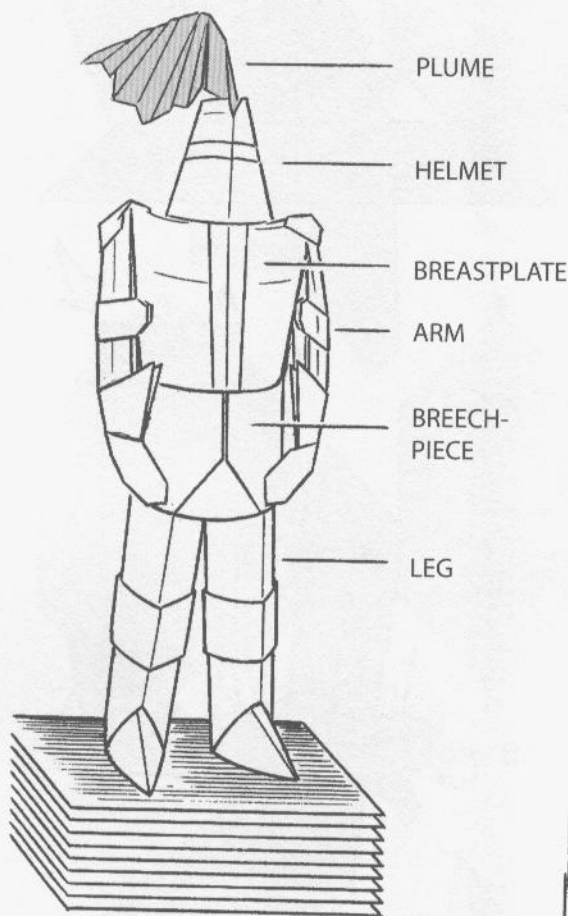

The joining of the helmet and the breastplate should be done very carefully, so that it will be very strong.

The same is true for the rounding of the arms.

The final height of the armor is $1\frac{1}{2}$ times that of one side of the paper squares used.

It's best to use paper 6 inches square.

Round the shoulders a little.

The metallic or chrome finish of the paper makes the figure look very realistic.

The armor is folded with 9 squares of equal size.

Eight of them should be of thick paper with metallic foil on the outside.

One should be of a bright color, to form the plume.

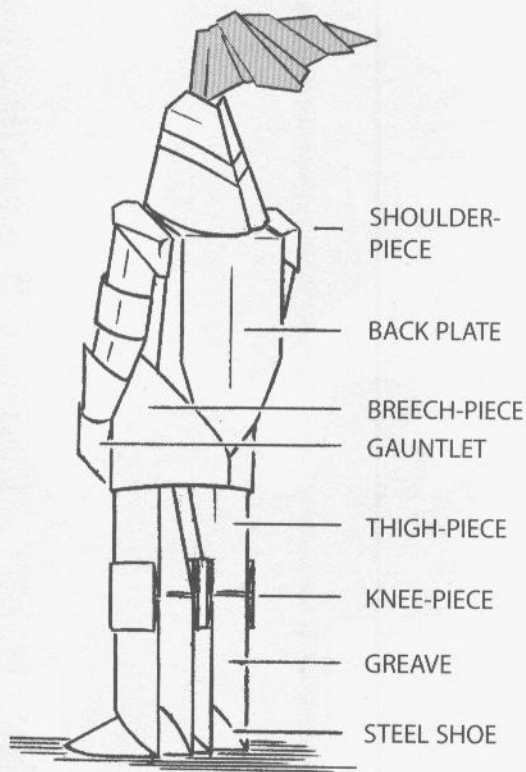

LEGS

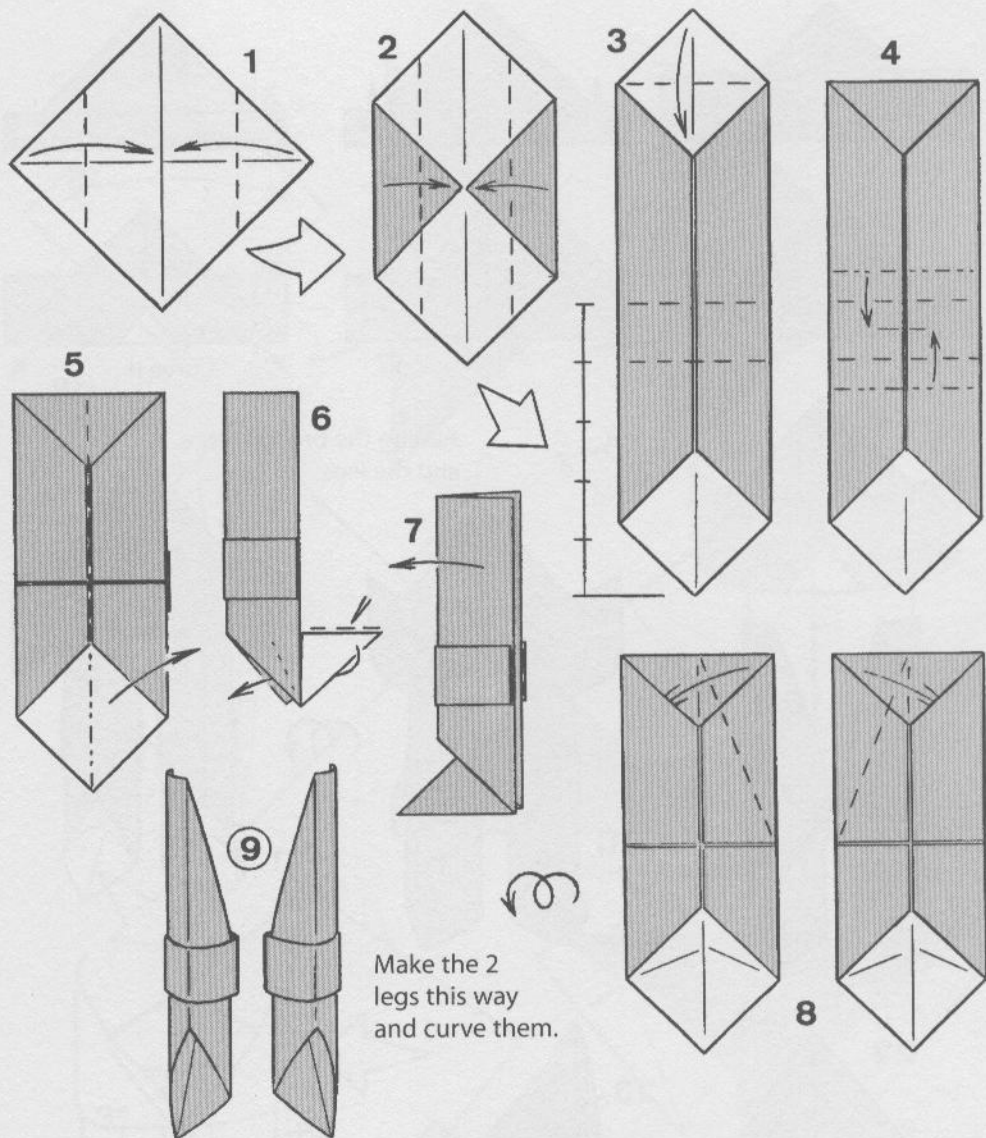

Make the 2 legs this way and curve them.

BREECH-PIECE

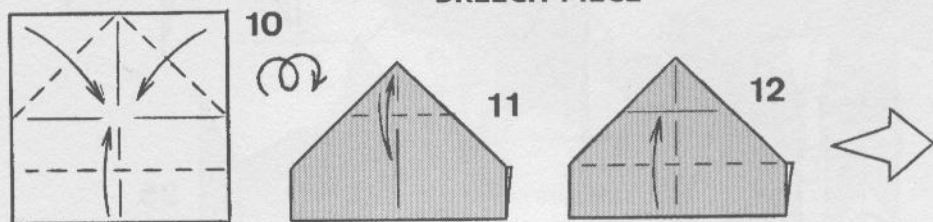

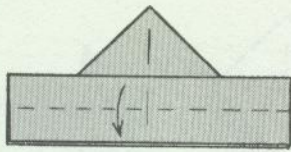

13

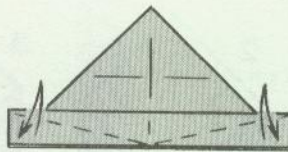

14

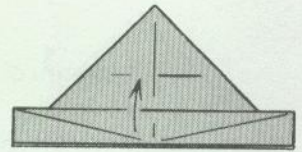

15

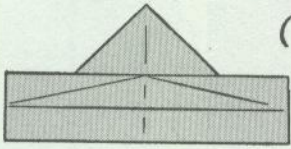

16

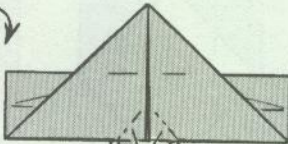

17

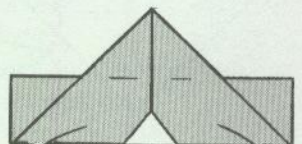

Curve it

18

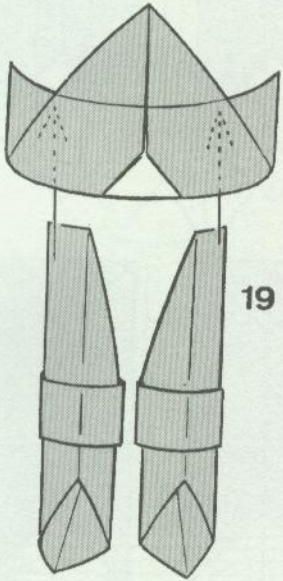

19

Joining the breech-piece and the legs:

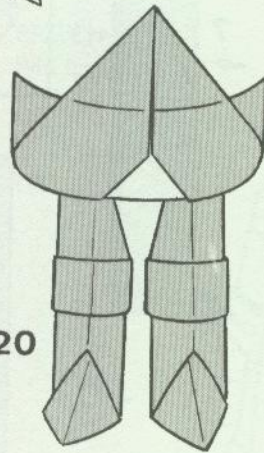

20

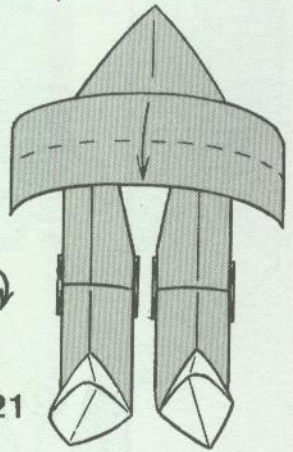

21

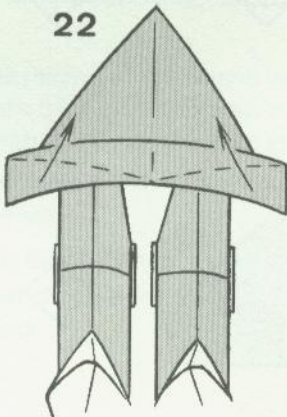

22

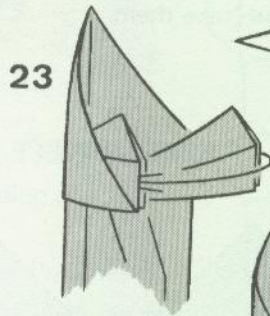

23

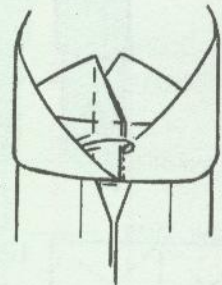

24

Closure of the Breech-piece:

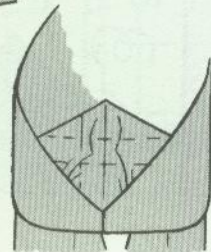

25

BREASTPLATE

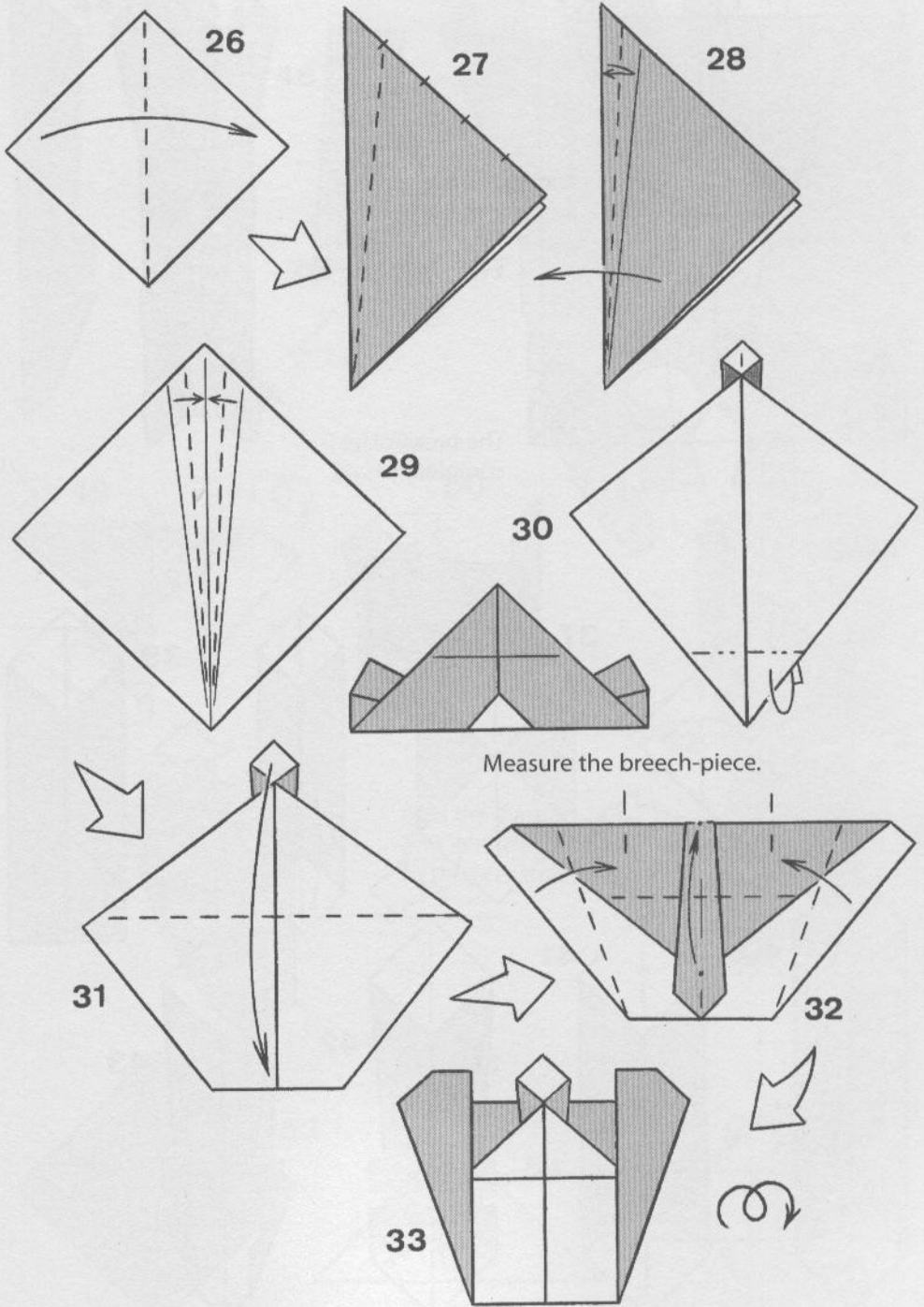

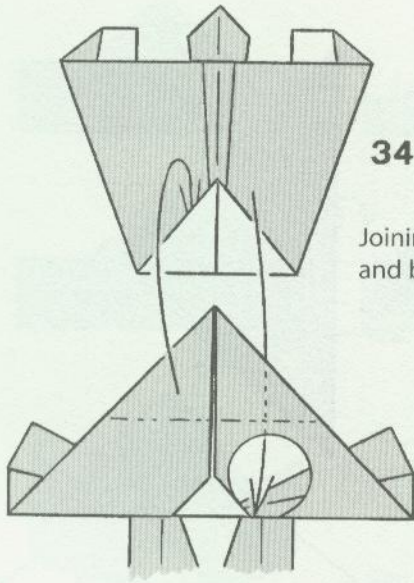

34

Joining the breastplate and breech-piece.

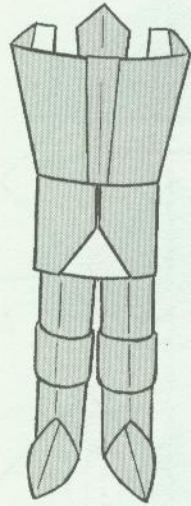

35

The breastplate is completely rigid.

ARMS

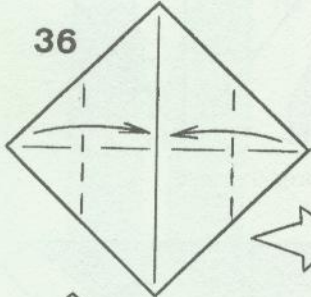

36

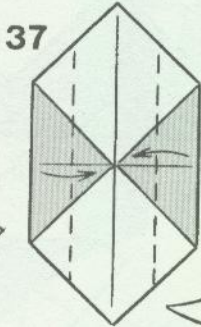

37

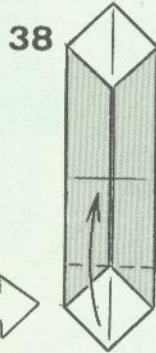

38

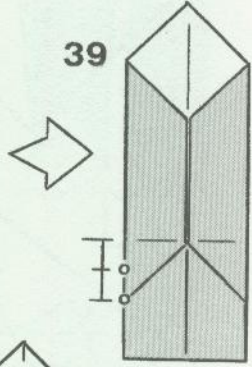

39

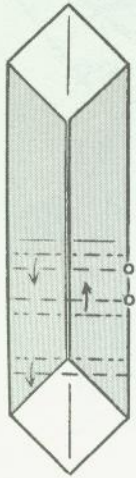

40

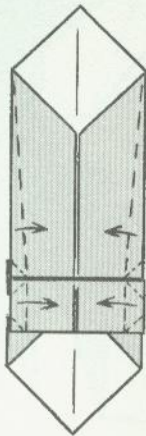

41

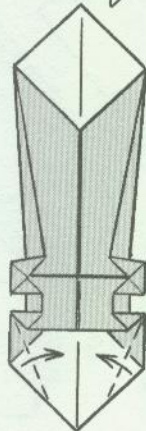

42

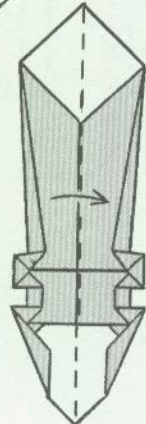

43

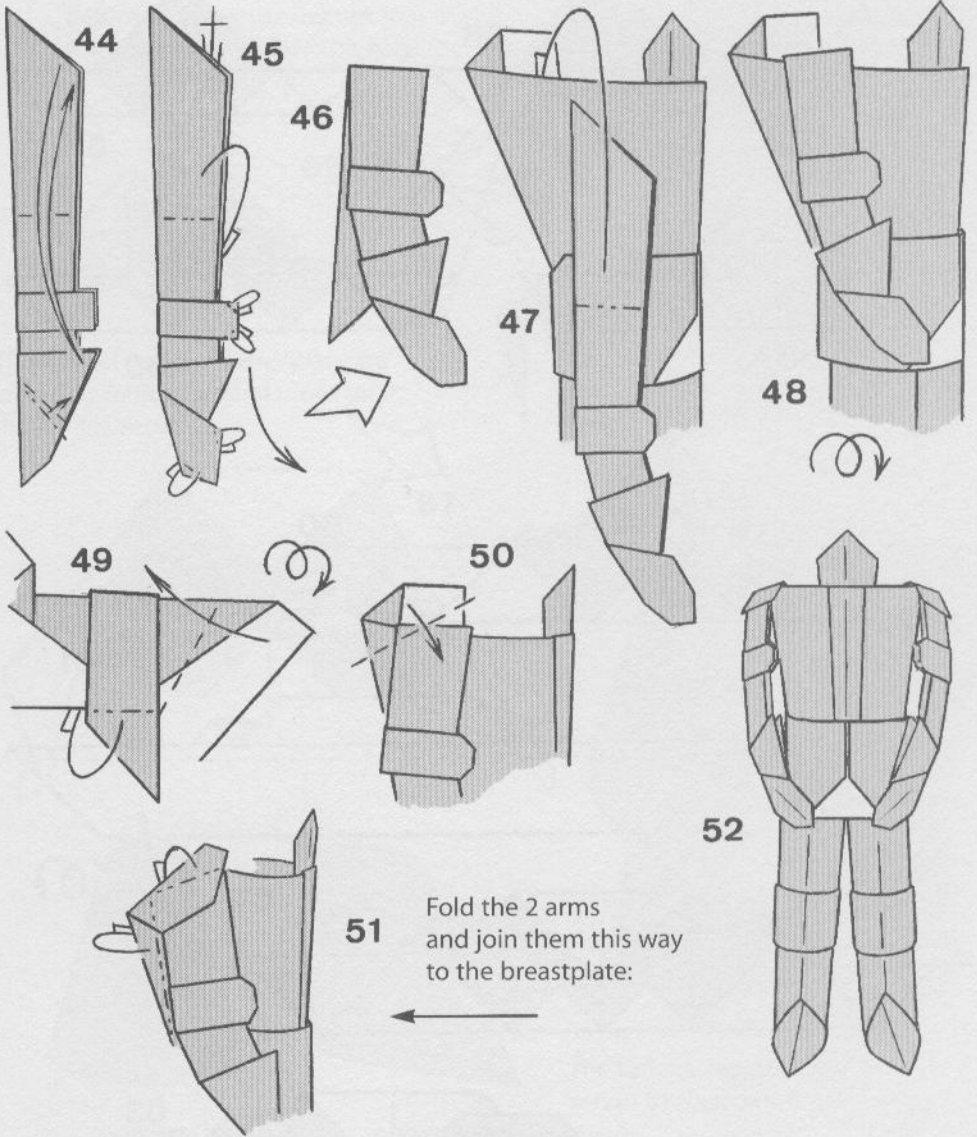

HELMET

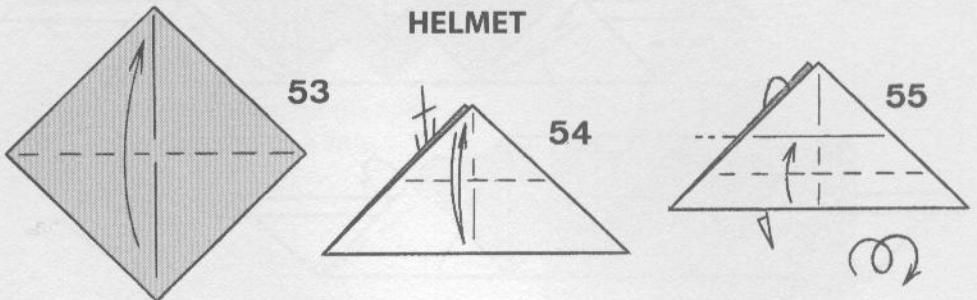

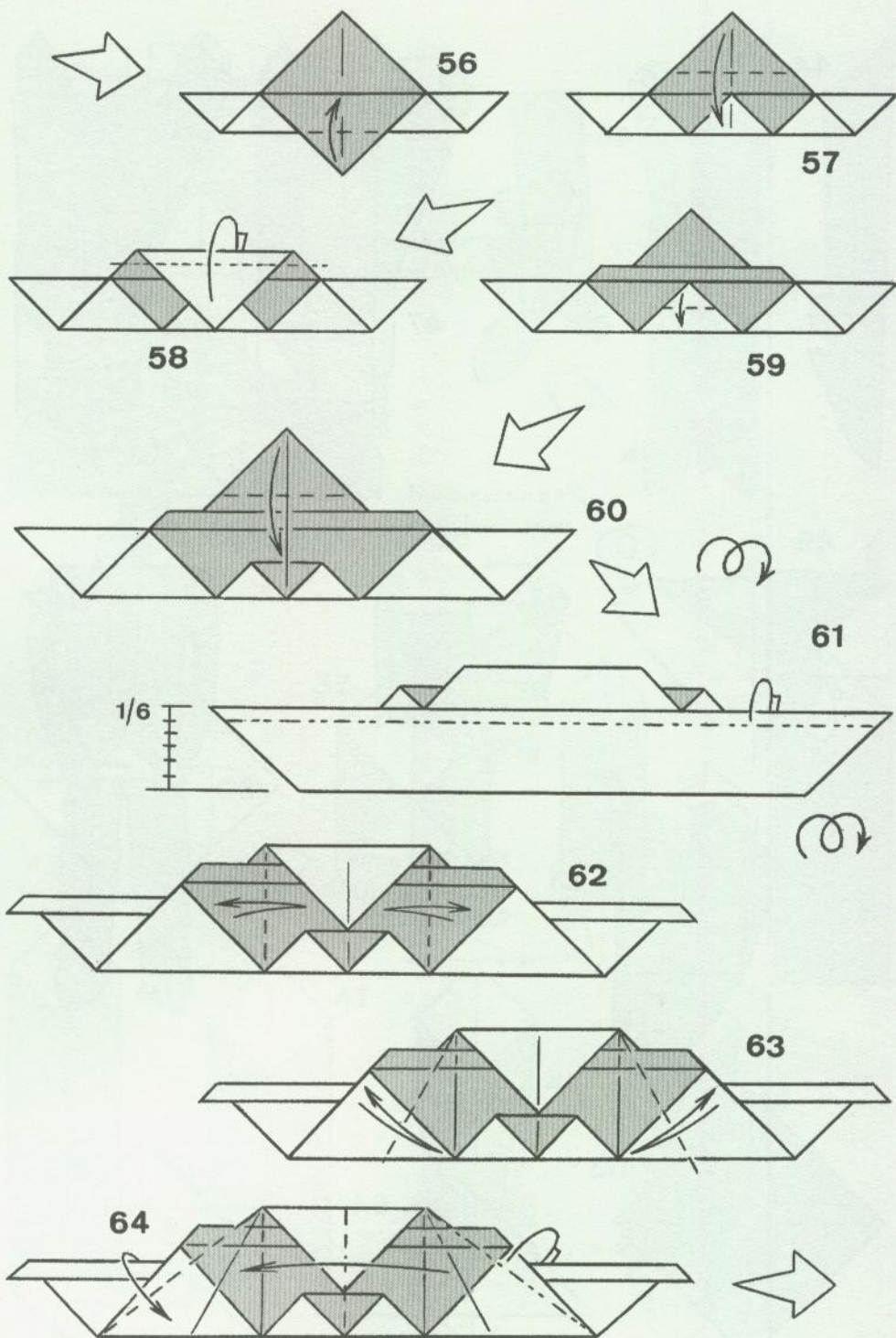

Before finishing the helmet, join it with the breastplate this way:

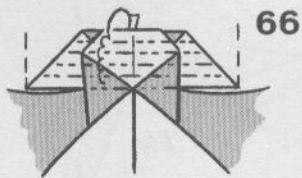

The helmet and the breastplate are joined by folding several times until the joint is secure.

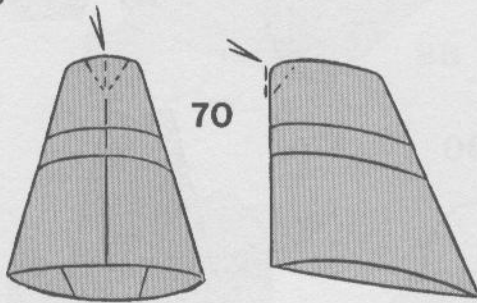
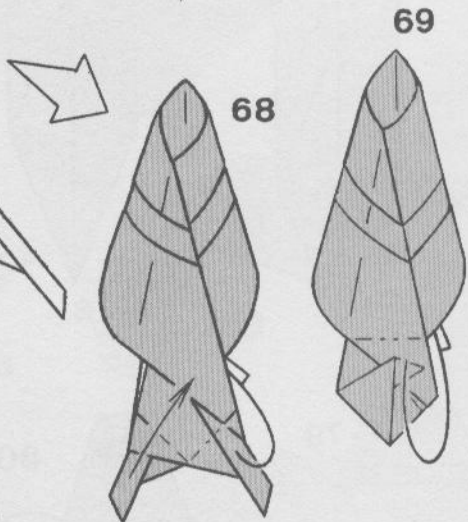
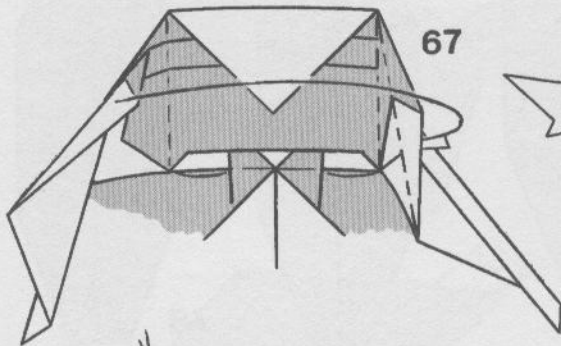
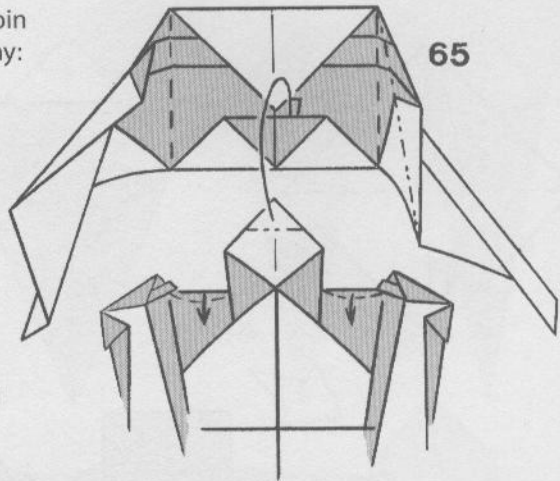

FRONT

PROFILE

The sinkage made at the top serves to close the crest or peak.

The helmet overlaps the edge of the breastplate a little.

71

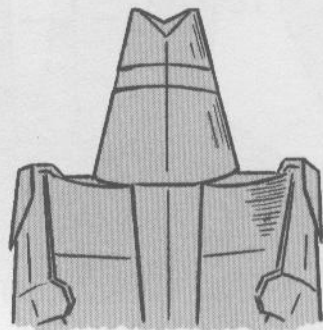

BACK

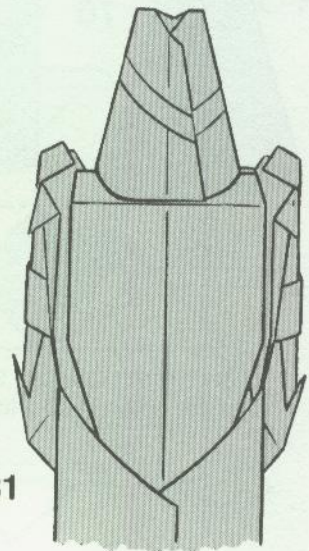
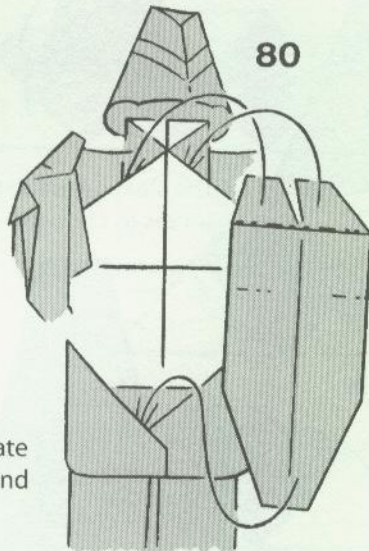
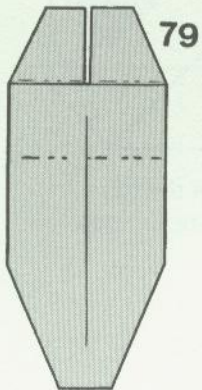
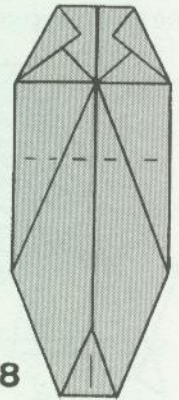
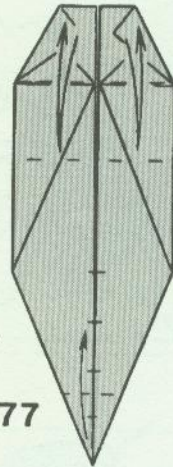
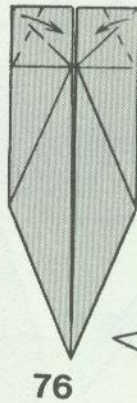
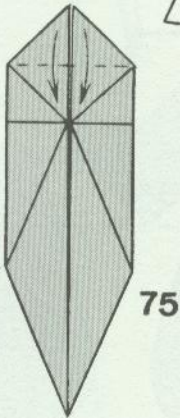
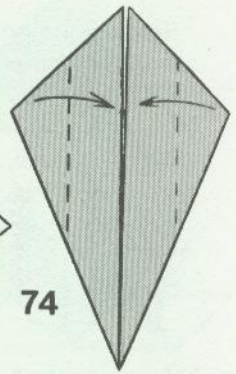
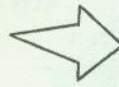
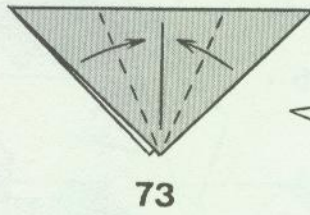
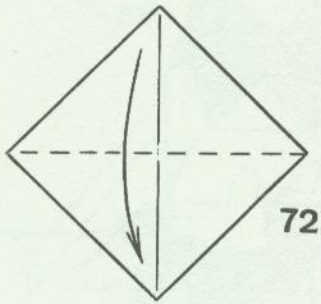

Joining the back plate to the breastplate and the breech-piece:

PLUME

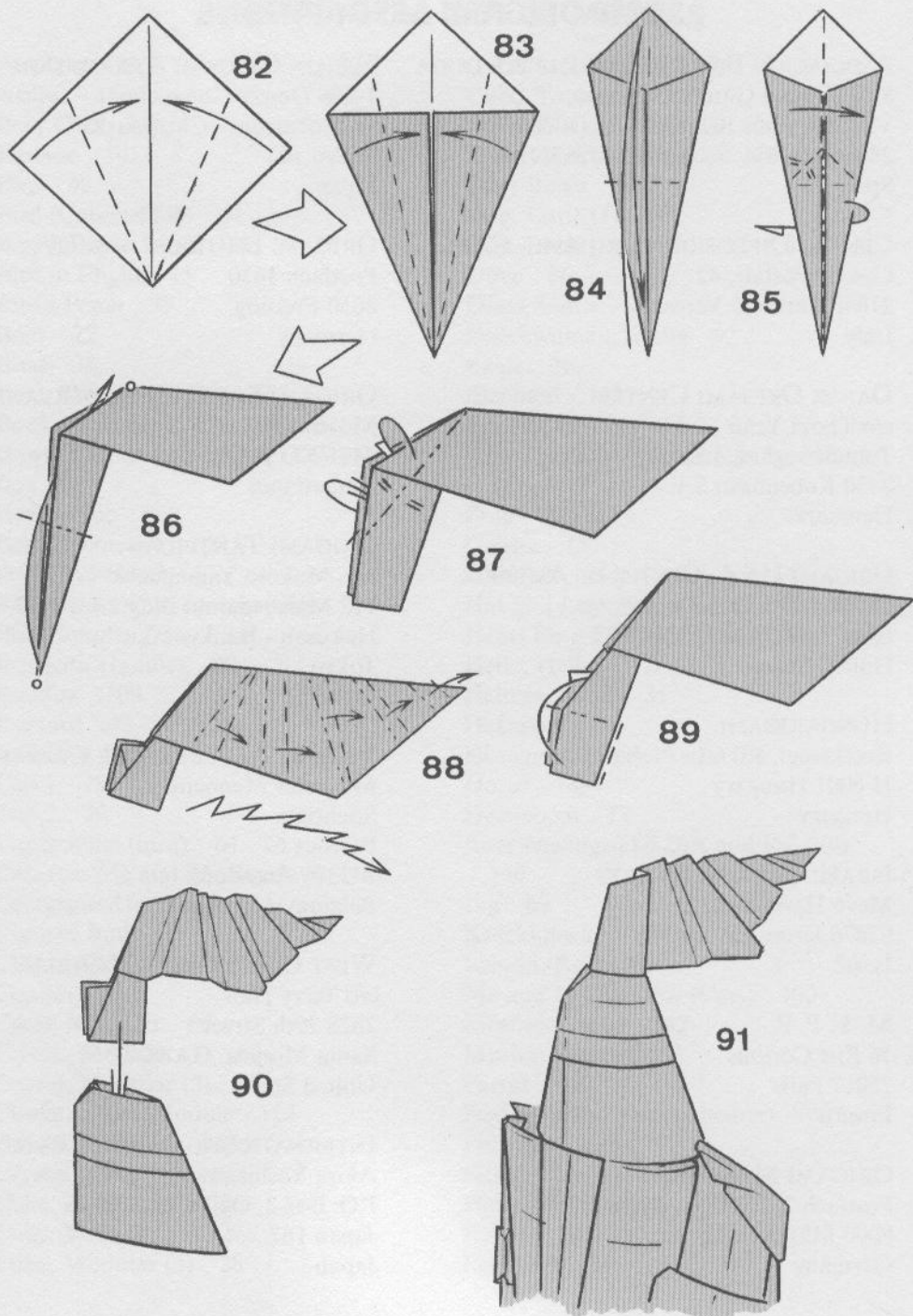

SOME ORIGAMI ASSOCIATIONS

ASOCIACIÓN ESPAÑOLA DE PAPIROFLEXIA
Sr. D. Julián García Gutierrez
Víctor Andrés Belaunde, 8 - Oficina 11
28016 Madrid Tel. 91.4576711
Spain

CENTRO DIFFUSIONE ORIGAMI - C.D.O.
Casella Postale, 42
21040 Caronno Varesino
Italy

DANSK ORIGAMI CENTER
c/o Thoki Yenn
Tranehavegard, 1 St. tV, 101
2450 Kobenhavn S.V.
Denmark

ORIGAMI U.S.A. CENTER OF AMERICA
15 West 77th Street
New York, N.Y. 10024-5192
United States

HUNGARIGAMI
Kecskemet, P.f. 60
H-6001 Hungary
Hungary

ISRAEL ORIGAMI SOCIETY
Mevo HaAsara 1/22
97876 Jerusalem
Israel

M. F. P. P.
56 Rue Coriolis
75012 Paris
France

ORIGAMI MÜNCHEN
Postfach 221324
8000 München 22
Germany

NIPPON ORIGAMI ASSOCIATION
1-096 Domir Gobancho
12-Gobancho - Chiyoda-Ku
Tokyo 102
Japan

ORIGAMI DEUTSCHLAND EV
Postfach 1630
8050 Freising
Germany

ORIGAMI SOCIETEIT NEDERLAND
Mossinkserf, 33
7451 XD Holten
Netherlands

ORIGAMI TANTEIDAN
Mr. Makoto Yamaguchi
112 Matsuedaiuhi Bldg 2A 5-36-7
Hakusan - Bunkyou-ku
Tokyo
Japan

VLAAMS NEDERLANDSE ORIGAMI
Mr. Peter Mennens
Stichting,
Postbus 62
B-2370 Arendonk
Belgium

WEST COAST ORIGAMI GUILD
c/o Terry Hall
2628 29th Street
Santa Monica, CA 90405
United States

INTERNATIONAL ORIGAMI CENTRE
Akira Yoshizawa
P.O. Box 3, Ogikubo - Tokyo
Japan 167
Japan

ALPHABETICAL LIST OF MODELS

- Airplane 32
Armor 164
Bear Cub 134
Biplane 161
Bird 48
Bird (Capercaillie) 64
Bird in Boat, Little 103
Bird in Flight 45
Bird's Perch 39
Boat 22
Boat 38
Boat, Two-Seat 82
Bookmark, Little Bird 30
Bowl or Open Receptacle 155
Box 23
Box, Cubic 55
Box, Decorated 105
Box, Five-Sided 49
Box, Irreversible-Process 66
Box, Simple 71
Box with Handles 90
Buddha 109
Buzzard 47
Camellia 96
Cap 1 19
Cap 2 20
Capercaillie (bird) 64
Cats (*see* Me and My Shadow) 100
Centerpiece for Table 24
Chinese Junk 85
Clicker and Its Variant 13
Condor 46
Cross, Modular 69
Crown, Modular (1) 67
Crown, Modular (2) 70
Crown, Seven-Module 114
Crown, Wilfred's 112
Crystal 54
Cube, Modular (1) 26
Cube, Modular (2) 27
Cube, Modular (3) 28
Cube, Modular (4) 29
Cube, Truncated 89
Cube, Winged 21
Ditetrahedron, Modular 74
Dog, Boxer 129
Dog, Little (1) 107
Dog, Little (2) 137
Dove 36
Dress, Girl's 17
Dutchwoman, Young 92
Eagle 76
Elephant 132
Feather for Cap 14
Fish That Opens and Shuts Its Mouth 98
Frog 50
Geisha 157
Goldfish 73
Hat and Legionnaire's Cap 15
Heart for a Drinking Glass 37
Hello, Hello! 57
Helmet, Celtic 31
Hexagon 119
Hexagons, Interlocked 106
Horse 139
Houseboat 72
Interweavings DZ-20A and DZ-20B 150
Jug 62
Knickknack 122
Lemon, Acid 60
Me and My Shadow (Cats) 100
Meeusen-esque 142
Muslim Praying 51
Parrot 43
Pentagon and Dodecahedron 34
Pinwheel 116
Pitufu 16
Plant in Flowerpot 87
Rabbit 94
Rowboat 40

Sailboat 42
Slippers, Persian 56
Snail Shell 78
Sparrow 25
Stand (for Cards, Photos, etc.) 41
Star 1 120
Star 2 121
Star, Eight-Module (1) 115
Star, Eight-Module (2) 152
Star, Five (or Six-Pointed) 59
Star, Five-Point (with cutting) 125
Star, Five-Point Modular 58
Stork 52
Swan 111
Swan, Lohengrin's 88
Terrier Dog, Little 33
Trough with Cranes 80
Vase 18
Waterwheel 145
Weasel 148
Whale, Little 127
Whistle That Whistles 63
Wrapper, "Tato" (traditional Japanese)
35
Wreath 117
Yacht 61

ORIGAMI FROM AROUND THE WORLD

VICENTE PALACIOS

Origamists in search of new and interesting challenges will find them in this treasury of 104 unusual origami projects with an international flavor.

Paper folders can select from a rich array of subjects from countries around the world and create such unique objects as a legionnaire's hat, a Buddha, a Celtic helmet, Lohengrin's swan, Persian slippers, a geisha and a Dutchwoman, a Chinese junk, a Muslim praying, and a suit of armor, as well as a vase, frog, bird in flight, stork, houseboat, horse, elephant, and more.

A useful list of symbols indicates basic folding instructions, while easy-to-follow, step-by-step diagrams and captions accompany each project, allowing paper folders at all skill levels to complete the folding process successfully.

Original Dover (2002) English translation of *Papiroflexia selecta*, published by Editorial Miguel A. Salvatella, S.A., Barcelona, 1998. 1,500 black-and-white illustrations. 176pp. 6½ x 9¼. Paperbound.

ALSO AVAILABLE

ORIGAMI FOR BEGINNERS, Vicente Palacios. 80pp. 6½ x 9¼. 40284-3

FASCINATING ORIGAMI, Vicente Palacios. 208pp. 6½ x 9¼. 29351-3

For current price information write to Dover Publications, or log on to www.doverpublications.com—and see every Dover book in print.

UPC



\$10.95 IN USA
\$16.50 IN CANADA

ISBN 0-486-42222-4

EAN

