

Experiment



IPHO 2018
Lisbon, Portugal

Q1-1

English (Official)

Paper transistor (10 points)

Electronic technology in modern society is based on a simple, yet powerful device: the transistor, which can be used both as a switch and as an amplifier. The switch mode is used for storage and processing of digital information.

Here we will analyse two types of Field Effect Transistors (FET): JFET (Junction Field Effect Transistor) and the TFT (Thin Film Transistor).

We shall briefly explain here how a FET works. A FET is a non-linear 3 terminal device (the terminals being named Gate: G; Source: S; and Drain: D) that can control the current flow between Source and Drain by acting upon the voltage applied between the Gate and the Source. In a simple, although imperfect analogy, a FET works similarly to a water tap, the knob acting as the Gate controlling the water flow.



Figure 1. Scheme of an n-channel JFET (left), its hydraulic analogy (middle) and electric circuit symbol (right). The arrows in the JFET scheme indicate the flow of the electric current between Source (S) and Drain (D) through the narrow n-channel. The width of the channel depends on the applied voltage between the Gate (G) and the Source (S).

The Junction-FET (JFET) relies upon the properties of the junction between two types of a semiconducting material, such as p and n doped silicon, hence its name. A JFET has a narrow channel through which the current flows between Source and Drain, and in a n-channel FET this channel is made of n-type material. The width of such channel can be controlled in a precise way by applying a **negative** voltage between the Gate and the Source, $V_{GS} = V_G - V_S$. For a fixed V_{GS} , the current flowing between Source and Drain depends non-linearly on the applied voltage between Drain and Source, $V_{DS} = V_D - V_S$. For small V_{DS} voltages, however, the current does depend linearly on the applied voltage, thus the JFET displays ohmic behaviour. The output resistance, $R_{DS} = V_{DS}/I_{DS}$, however, does depend strongly on the applied V_{GS} voltage, closely following the law:

$$R_{DS} = \frac{R_{DS}^0}{1 - V_{GS}/V_P}, \quad (1)$$

where R_{DS}^0 is the output resistance at $V_{GS} = 0$ and $V_P < 0$ is a JFET parameter called the *pinch-off voltage*. Clearly, at the pinch-off voltage, the FET blocks current flow.

For any fixed $V_{GS} > V_P$, the current between Source and Drain will start to depart from the linear behaviour as we increase V_{DS} , and will at some point saturate at an almost constant value. Let I_{DSS} be the saturation current when $V_{GS} = 0$. In the saturation regime (large applied V_{DS}), the saturation current will depend on V_{GS} in the following way:

$$I_{DS} = I_{DSS} (1 - V_{GS}/V_P)^2. \quad (2)$$

Experiment

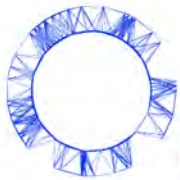

IPhO 2018
Lisbon, Portugal

Q1-2

English (Official)

We should stress two very important characteristics of a JFET. Although its voltage controlled output resistance can be quite low, the input resistance ($R_{GS} = V_{GS}/I_{GS}$) is extremely high, typically larger than $10^9 \Omega$, so this device uses very little input current. Also, the capacitance of a small JFET is quite low making it a very fast device than can 'open and close' beyond MHz rates.

We now proceed to describe how a different type of FET, the TFT, works.

As any other FET, the TFT permits the control of a current between two contacts, the Drain and Source electrodes, by means of an applied potential at the third electrode, the Gate.

The Gate electrode is physically separated from the semiconductor layer by a dielectric that allows for the establishment of a vertical electrical field that will control the free charge carriers existing in the semiconductor (field effect). The dielectric layer can be replaced by an electrolytic membrane such as paper where mobile ions exist (see Figure 2) and in this case the voltage applied at the Gate will push ions with opposite charge to the semiconductor interface, creating a sheet of ionic charges that will modulate the free carriers' density existing within the semiconductor (Electrolyte Gated Transistors - EGTs). Researchers at Universidade Nova, Lisbon, were pioneers in developing in 2008 the "paper transistor", and are world leaders in this field.

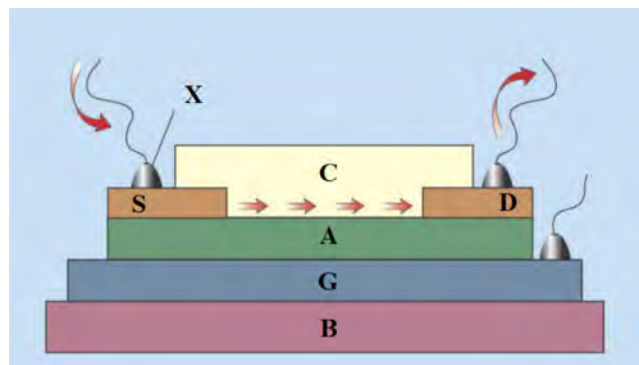

Figure 2. Scheme of the paper thin film transistor (TFT) to be used in this problem. S - Source; D - Drain; G - Gate; A - paper (dielectric); B - substrate; C - semiconductor layer (Gallium-Indium-Zinc oxide (GIZO)); X - Metal contacts. The arrows indicate the conventional current flow.

Similarly to JFETs, TFT transistors can operate in two fundamental operation modes, a linear mode and a saturation mode. In contrast to JFET, TFT intrinsic capacitance is a relevant parameter for the device performance.

In this experimental problem you will examine how an n-channel JFET and a paper TFT work.

You will determine the Characteristic Curves (CCs) of these devices by measuring the current between S and D (I_{DS}) through the application of distinct voltages at G (V_{GS}) and D (V_{DS}).

The two most important CCs are the output and the transfer curves:

- **Output Curve:** For this curve the current between Source and Drain (I_{DS}) will be measured and plotted as a function of the voltage between Source and Drain (V_{DS}), with V_{DS} swept from 0 V up to +3 V, in steps, while keeping V_{GS} constant.
- **Transfer Curve:** For this curve I_{DS} will be measured and plotted against V_{GS} . V_{DS} will be kept constant at a suitable value for the transistor to work in the **saturation mode** and V_{GS} will be swept in steps from -3 to 0 V.

Experiment

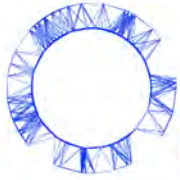

IPhO 2018
Lisbon, Portugal

Q1-3

English (Official)

Equipment

The following set of equipment (Figure 3) is provided for this experimental problem:

1. multimeter
2. JFET transistor (provided inside a labelled plastic bag)
3. cables (10) with alligator clips
4. flat alligator clips (4, provided inside a plastic bag)
5. battery pack (4×1.5 V)
6. battery holder
7. mini-breadboard with support
8. jumper wires (3) to connect to the mini-breadboard
9. HB pencil
10. silver ink conductive pen (Circuit Scribe)
11. chronometer
12. sheet of paper with printed circuits and an embedded TFT that uses paper as dielectric layer (Figure 4)
13. bag with writing material (1 pen, 1 pencil, 1 eraser/sharpener, 1 ruler)

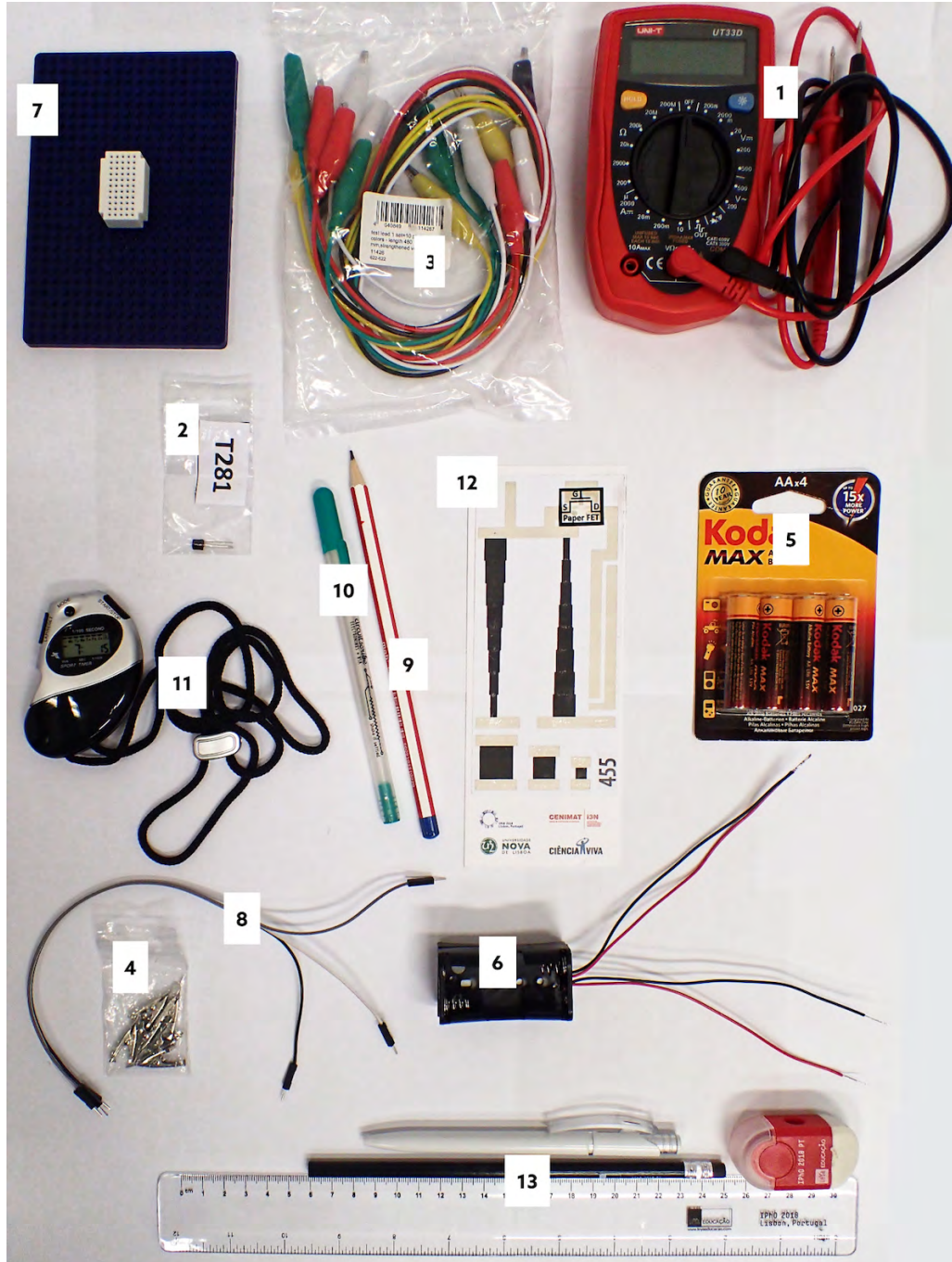

Figure 3. Equipment set.

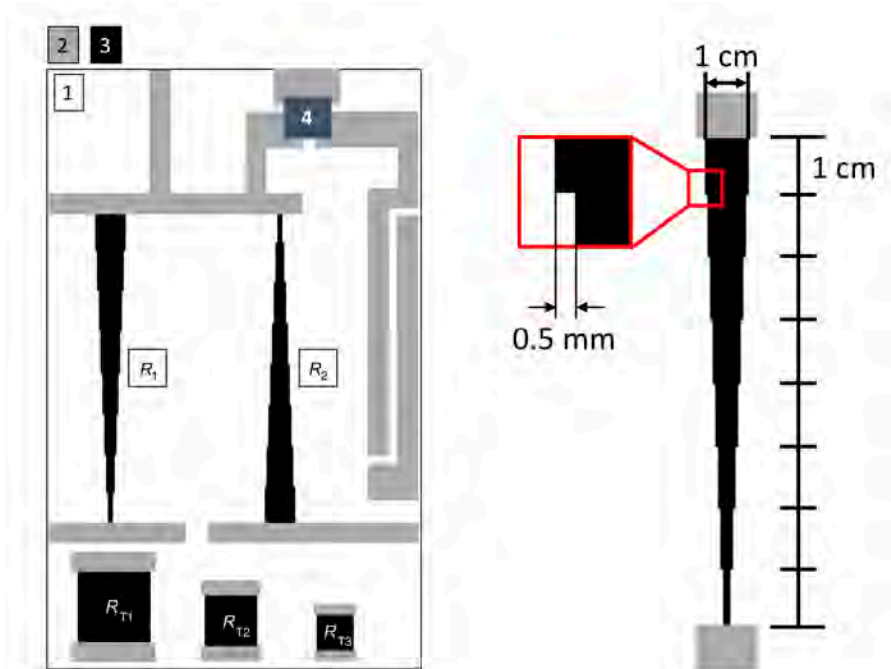
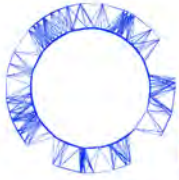
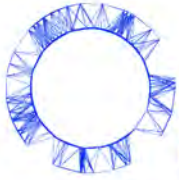

Figure 4. Left: Sheet of paper with printed circuits included in the equipment: paper (1), silver conductive tracks (2), carbon resistive tracks (3), paper transistor (4), voltage divider resistances (R_1 and R_2). Right: Physical dimensions of the voltage divider resistances (the steps of 0.5 mm are constant for each segment).

Important precaution:

Do not fold the sheet of paper with the printed circuits and embedded transistor as this will easily damage it. Try to leave it as flat as possible during measurements in order to reach best results.

For the measurements it is important to take into account the following **important information**:



- The multimeter should always be operated in **DC mode**.
- The multimeter does not autorange and you should carefully choose the most appropriate ranges for your measurements. In case a overflow occurs the display will show either "1" or "-1" (left justified on the display), for positive and negative values, respectively, and you should change to a lower range.
- The low-current ranges are protected by a 315 mA fuse. **Avoid by all means to create a short circuit** between the battery and the multimeter because a high current will blow up the fuse!
- The internal resistance of the multimeter when operating in voltmeter mode is $10\text{ M}\Omega$.
- When operating as ammeter, the internal resistance of the multimeter depends on the range as shown in the following table:

Range	R_{int}/Ω
200 mA	1.0
20 mA	10
2 mA	100

Table 1. Internal resistance of the provided multimeter when operated as ammeter.

Thus, when the multimeter is being used in DC ammeter mode, there will be a voltage drop up to 200 mV between its terminals at full scale when operated in any of the 3 available DC ranges.

Part A. Circuit dimensioning (2.5 points)

To achieve the necessary V_{DS} and V_{GS} voltages you will use two carbon resistors printed on paper (R_1 and R_2 , see Fig. 4) and voltage divider circuitry to dimension the circuit for the right potential drops. R_1 and R_2 will be the total resistance (R_{tot}) of a voltage divider circuit. When applying a constant voltage (in this case about 3 V from the battery) across R_1 , for instance, we will see a voltage drop along it from 3 V (V_{in} , the positive contact of the battery) to ground (0 V; from now on, we designate as ground the common contact of the two battery packs). R_{tot} can be divided into essentially two resistances (R_x and R_y) to achieve the desirable V_{out} (Figure 5).

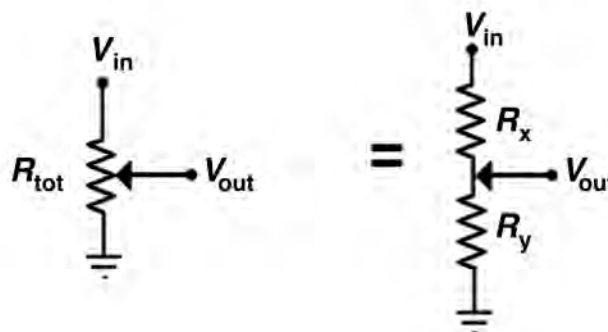
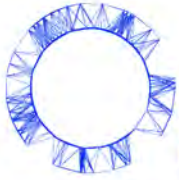

Figure 5. Voltage divider circuit.

Experiment



IPhO 2018
Lisbon, Portugal

Q1-7

English (Official)

- | | | |
|------------|--|-------|
| A.1 | Write down the expression for the output voltage, V_{out} , as a function of V_{in} and resistances R_x and R_y . | 0.2pt |
| A.2 | Measure the resistance of the three test resistors on the bottom part of the sheet (R_{T1} , R_{T2} and R_{T3}) with the multimeter. Carry out enough measurements with different positions on the silver contacts. Enter the values in the Answer Sheet. Calculate the average value and estimate the uncertainty for the resistance of each test resistor. | 0.5pt |
| A.3 | Show that the resistance of a square thin film with a certain resistivity, ρ , should be independent of the length of its side. This size-independent resistance is called <i>sheet resistance</i> and is denoted R_{\square} . | 0.3pt |
| A.4 | Calculate the average value of the sheet resistance of the carbon film from the data in A.2 and obtain the resistivity, ρ , of the carbon film with an estimation of its uncertainty (consider a thickness t of the carbon film of $20 \pm 1 \mu\text{m}$). | 0.4pt |
| A.5 | Show that the theoretical value of the R_1 and R_2 resistances is $R_1 = R_2 = \kappa R_{\square}$, $\kappa \sim 14.2897$. Measure R_1 and R_2 and write down the values in the Answer Sheet. Determine the experimental value of κ and compare it with the theoretical value. | 0.5pt |

Using the provided silver ink pen, draw 7 equally spaced conductive lines along each of the provided resistors (as exemplified in Figure 6). These individual lines will serve as the contact points for the voltage dividers.

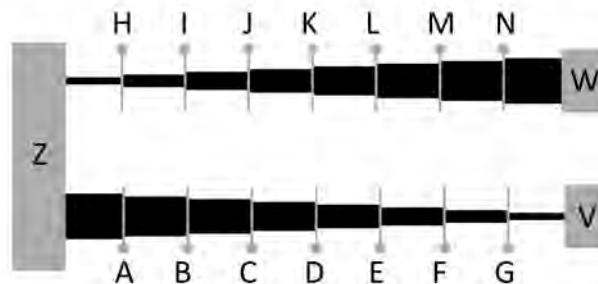

Figure 6. Line drawing example and naming scheme of the contact points.

- | | | |
|------------|---|-------|
| A.6 | Measure the resistances R_x and R_y for all contact points. R_x is defined as the resistance between the contact point and points V (resistor 1) or W (resistor 2), and R_y is defined as the resistance between the contact point and point Z. Fill the provided tables in the Answer Sheet. | 0.3pt |
|------------|---|-------|

Insert the 4 AA batteries in the battery holder. Please observe carefully the correct battery polarity and

Experiment



IPhO 2018
Lisbon, Portugal

Q1-8

English (Official)

make sure you do not produce a short circuit. Then, physically connect the battery pack as depicted in Figure 7. Make sure you do not damage the silver tracks with the alligator clips.

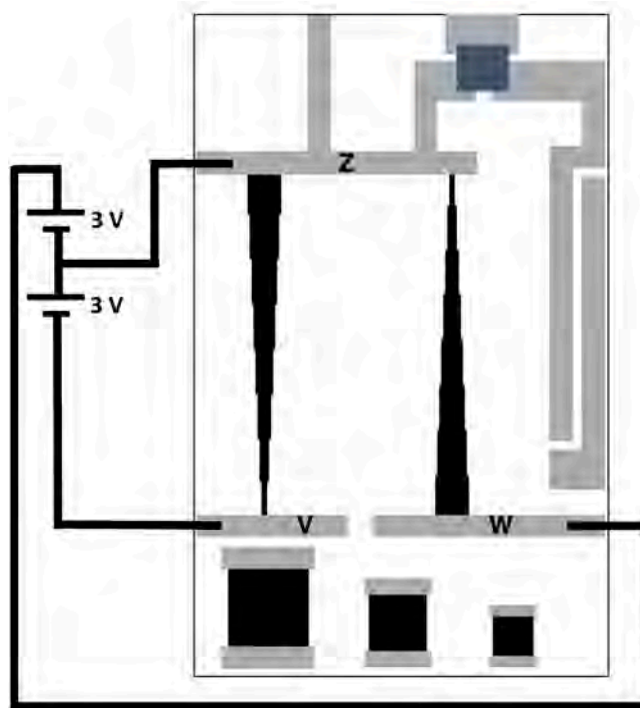

Figure 7. Battery connections

- A.7** Measure V_{out} at each contact point, V_{out} being the voltage measured with respect to point Z and enter the values in the provided tables in the Answer Sheet. 0.3pt

This concludes the circuit dimensioning part and you can now proceed to measure the CCs of the JFET transistor.

Part B. Characteristic Curves of the commercial JFET transistor (4.5 points)

In order to characterise the JFET transistor you will use the setup depicted in Figure 8. Start by identifying the three contacts (S, D and G) on the provided JFET transistor - **pay attention to the correct identification of the contacts, as the device is not symmetric!** You may use the provided minibreadboard with support to mount the JFET transistor. The provided jumper wires are to be used with the mini-breadboard.

Using the provided cables, connect the Gate and the Source of the transistor to ground (point Z of the circuit, at 0 V). Throughout this part of the problem, the Source of the JFET should always be kept connected to ground.

Experiment

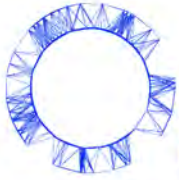

IPhO 2018
Lisbon, Portugal

Q1-9

English (Official)

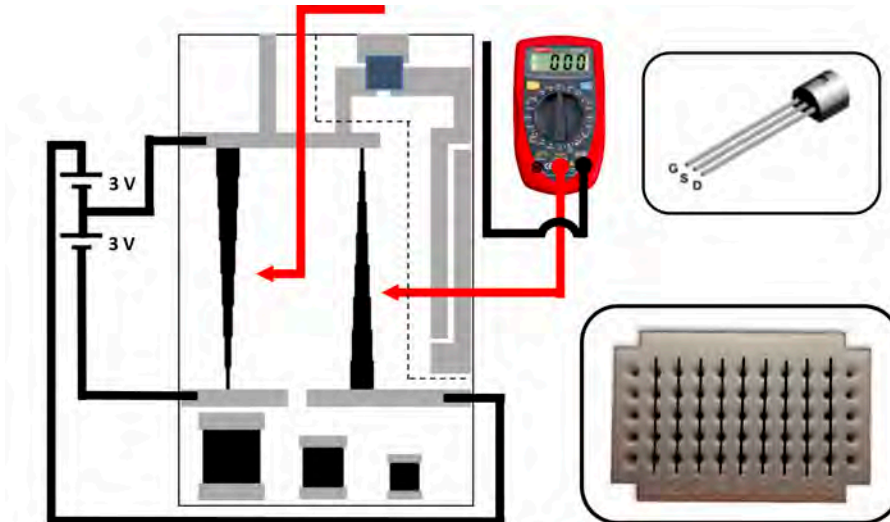
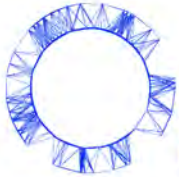

Figure 8. Setup for the determination of the JFET characteristic curves. The part of the circuit inside the dashed region that includes the TFT is not to be used in part B of the problem. The top inset shows how to identify the Gate, Source and Drain of the JFET transistor. The bottom inset shows how the holes of the mini-breadboard are connected. All holes in a numbered column are internally interconnected and isolated from the holes of other columns. The picture of the multimeter is merely illustrative: you are in charge of selecting the appropriate measuring mode and range in the rotary selector of the multimeter.

- B.1** Connect the gate of the transistor to ground ($V_{GS} = 0$). Then connect one of the cables of the multimeter, that should be used in DC current mode, to the drain of the transistor and with the other cable touch the point with the highest voltage available in the voltage dividers. Write down in the answer sheet the value of the current I_{DS} . 0.2pt
- B.2** Measure the current I_{DS} for different positive voltages applied to the Drain, while keeping $V_{GS} = 0$. Then change the circuit to apply a negative voltage between the Gate and the Source of the transistor ($V_{GS} < 0$) and repeat the measurements of I_{DS} as a function of the positive applied voltage between Drain and Source. Fill with your values the tables provided in the Answer Sheet. 0.8pt

When the voltage divider circuit is connected to a low resistance load (Figure 9), the voltage values provided by the voltage divider, V_{out}^L , are different from the nominal values V_{out} measured when the load is a high resistance, such as the case of a high impedance voltmeter.

Experiment



IPhO 2018
Lisbon, Portugal

Q1-10

English (Official)

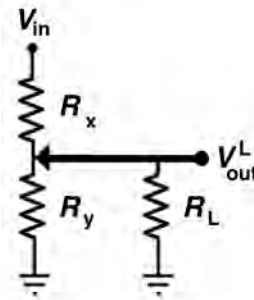

Figure 9. Voltage divider with a load.

- B.3** Consider that the voltage divider is connected to a load R_L . Obtain an expression for the correction factor $f = V_{out}^L/V_{out}$ as a function of R_L , R_x and R_y . 0.2pt

The JFET transistor has a low output resistance when $V_{GS} = 0$, namely $R_{DS}^0 \sim 50 \Omega$. However, this resistance increases significantly when the Gate is polarised negatively with respect to the Source. For $V_{GS} < 0$ the output resistance follows closely the law given by equation (1).

- B.4** Using the appropriate correction factors, calculate V_{DS} , the voltage drop between Drain and Source, for all the points measured in B.2. Consider the following nominal data for the JFET used in this problem : $R_{DS}^0 = 50 \Omega$, $V_p = -1.4 \text{ V}$. 1.2pt

- B.5** Plot the output curves $I_{DS}(V_{DS})$ for your JFET transistor. 0.5pt

- B.6** Consider the transistor in operation at small V_{DS} . Obtain the *experimental* values of R_{DS} of your JFET for different V_{GS} and plot the data. 0.5pt

- B.7** Plot the transfer curve $I_{DS}(V_{GS})$ of your JFET transistor for $V_{DS} \sim +3 \text{ V}$. 0.3pt

When the JFET transistor is in saturation mode, the current I_{DS} follows closely the law expressed by equation (2).

- B.8** From the measured data, obtain I_{DSS} and the *pinch-off* voltage, V_p , for your device. Compare the value obtained of V_p with the nominal value. 0.4pt

An important parameter of a JFET transistor, in particular when it is used in amplifiers, is the so called transistor transconductance, g , defined as

$$g = \frac{\partial I_{DS}}{\partial V_{GS}}. \quad (3)$$

For a function of two variables $f(x, y)$, the notation $\frac{\partial f}{\partial x}$ means the derivative of f with respect to x when y is kept constant.

Experiment

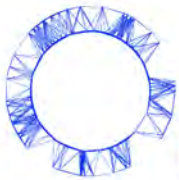

IPhO 2018
Lisbon, Portugal

Q1-11

English (Official)

- B.9** Obtain, from the measured transfer curve, the transconductance of your device for $V_{GS} = -0.50$ V. Compare it with the calculated value obtained from the model equation (2). 0.4pt

Part C. The Paper Thin Film Transistor (2.0 points)

From now on, you discard the JFET, and all following tasks and questions relate to the paper thin film transistor (TFT) located in the upper corner of the printed circuit. The TFT Gate, Source and Drain are marked in Figure 10. Connect the TFT Gate and the Source to ground. Also in this part of the problem the Source of the paper TFT should always be connected to the common contact of the battery packs, i.e. 0 V, as shown in Figure 10. Polarise the transistor with $V_{DS} > 0$, via one of the voltage circuit dividers (Figure 10). Check that a current is flowing through the ammeter.

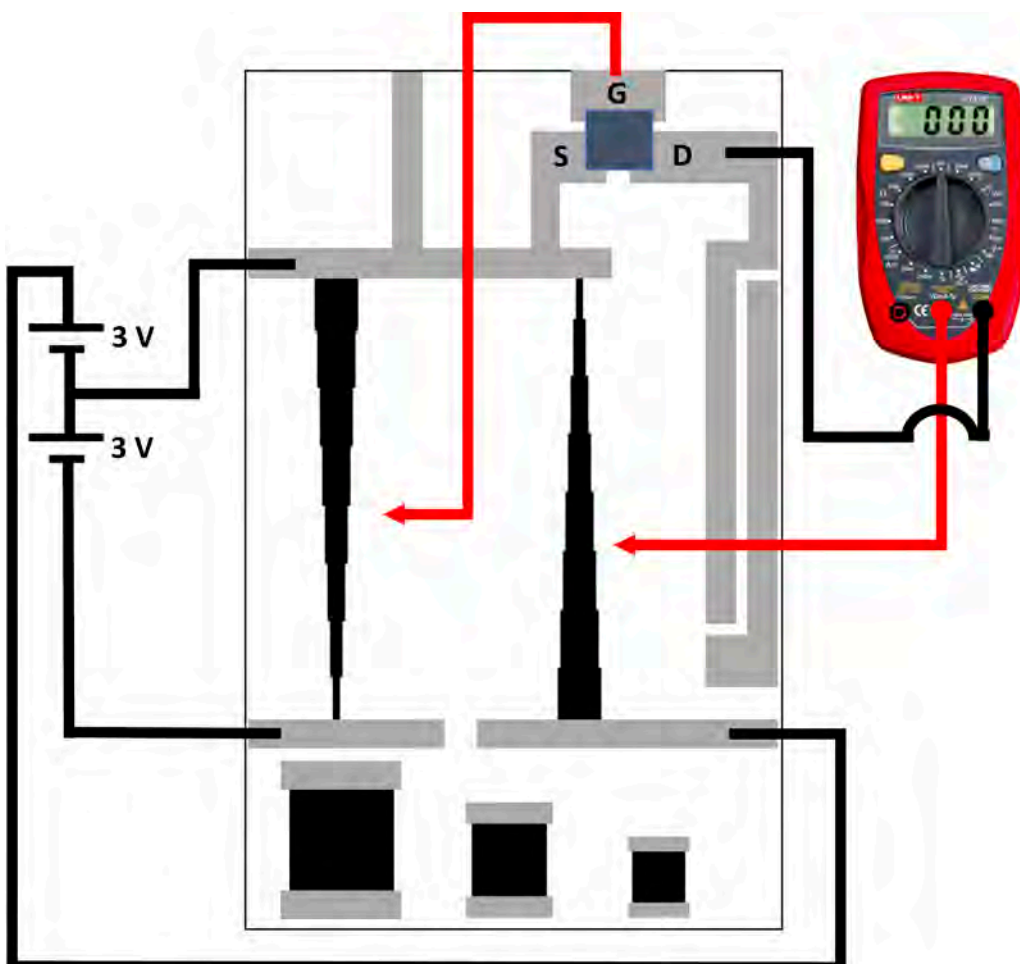

Figure 10. Setup for measurements on the paper TFT. The picture of the multimeter is merely illustrative: you are in charge of selecting the appropriate measuring mode and range in the rotary selector of the multimeter.

Experiment



IPhO 2018
Lisbon, Portugal

Q1-12

English (Official)

C.1 Apply $V_{DS} = +3.0$ V. Close the transistor by applying $V_{GS} = -3.0$ V. Wait for 1 min so that the the transistor closes. Write down in the answer sheet the residual value of the current, I_{closed} . Then open the transistor by putting $V_{GS} = 0$, while keeping $V_{DS} = +3.0$ V. Measure the current as function of time, starting at the instant when you open the transistor, for at least 5 min and collect the data $I_{DS}(t)$ in the answer sheet. 0.8pt

C.2 Plot $I_{DS}(t)$. There is a superposition of two exponential processes in the time dependence, one with a much larger time constant (τ_2) than the other (τ_1). Determine the shorter time constant, τ_1 . 1.2pt

Part D. Inverter circuit (1.0 points)

In microelectronic circuitry one of the most important circuits is the inverter, that is able to invert a digital input. For instance if $V_{in} = \text{high}$ then $V_{out} = \text{low}$ and vice-versa. A transistor is once again at the basis of the circuit and one of the simplest designs is the so called common source amplifier, depicted in Figure 11, using a transistor and a load resistance (R_L). In this case $V_{in} = V_{GS}$ and V_{out} is the voltage measured at the Drain electrode of the transistor. Thus, in this part we will monitor what happens to V_{out} while sweeping V_{GS} from -3 V to 0 V.

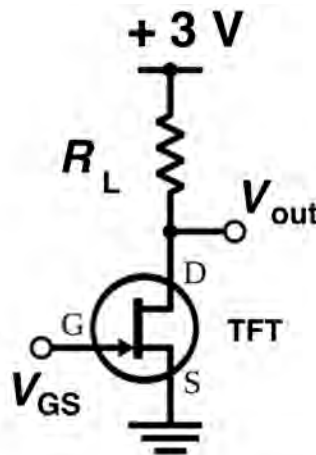

Figure 11. Common source amplifier and inverter circuit.

In the setup of Figure 11 the transistor is the paper TFT and R_L is a load resistance you are going to add now, manually, by connecting the Drain contact of the transistor with the V_{in} contact using a pencil track, as indicated in Figure 12. While you write, you are actually depositing thin layers of conductive graphite on the paper so the more layers you draw on top of each other, the lower the resistance will get. While drawing R_L make sure to continuously monitor its resistance. To pull V_{out} as close to 0 V as possible the load resistance should be large enough. So, while drawing the resistance, aim for a value close to the target value $R_L = 200$ k Ω .

You can either use the pencil to decrease R_L or the eraser to increase it. You should aim to obtain a value differing not more than 10% from the aimed value.

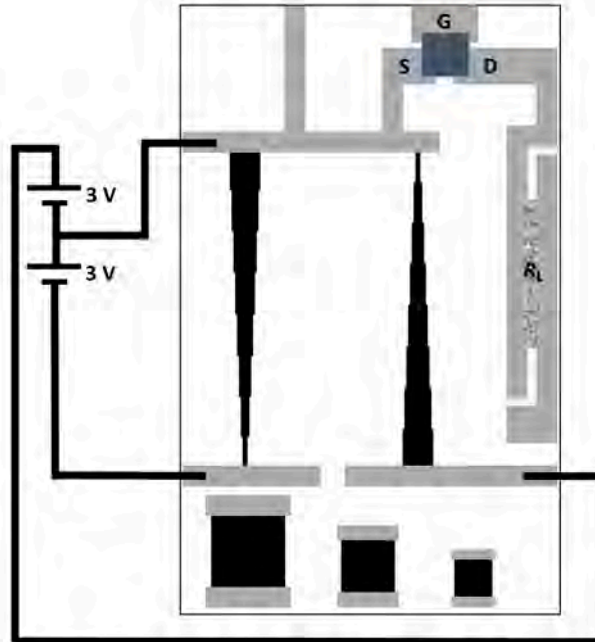
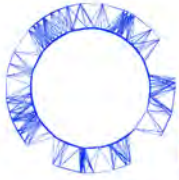

Figure 12. Setup for the inverter/common source amplifier configuration.

Use the included HB pencil and draw by hand a carbon resistor with value of $R_L \simeq 200 \text{ k}\Omega$ to be used as a load resistor of the paper TFT to build the inverter circuit (see Figure 12).

D.1 Write down in the Answer Sheet the measured R_L value you have reached. 0.5pt
Setup the inverter circuit (Figure 12) using the carbon track resistor and the paper TFT. Before the measurement, remember that you should turn the transistor fully off by applying $V_{GS} = -3 \text{ V}$ and wait for $\sim 1 \text{ min}$. Then measure V_{out} as you sweep V_{GS} from -3 V to 0 V and take readings of V_{out} with a stabilization time for each point up to a maximum of 100 s . Enter the measured values in the Answer Sheet.

D.2 Plot the measured $V_{out}(V_{in})$ voltage transfer curve and draw a smooth trend curve through the data points. 0.5pt

Experiment

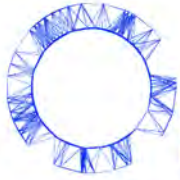

IPhO 2018
Lisbon, Portugal

Q2-1

English (Official)

Viscoelasticity of a polymer thread (10 points)

Please note that the thread must not be stressed before the beginning of the experiment!

Switch on the scale right now (warming time is about 10 minutes). Do not change the settings of the scale.

Introduction

When a solid material is subject to an external force, it deforms. For small applied forces, this deformation is proportional to the force (Hooke's law) and is reversible, so that the material recovers its initial shape when the force is removed.

For a solid, the description is more conveniently expressed using the concepts of stress and strain. The stress σ is defined as the force per unit area, i.e. the force F divided by the area S on which it acts, whereas the strain, ϵ , is the relative change of length:

$$\sigma = \frac{F}{S} \quad \text{and} \quad \epsilon = \frac{\ell - \ell_0}{\ell_0}, \quad (1)$$

where ℓ and ℓ_0 are the final and original length, respectively. In the simple elastic behaviour, the stress is simply proportional to the strain $\sigma = E\epsilon$ (Hooke's law) and the proportionality factor, E , is named *modulus of Young*.

The elastic behaviour expressed in Hooke's law is an approximation valid only for small enough strains. For higher strains changes gradually become irreversible as the plastic regime is reached, in which case the molecular movements start to be unconstrained, resembling those of a viscous fluid. That is, if stretched or compressed beyond the elastic limit, the material becomes asymptotically fluid.

Viscoelastic materials

Certain materials combine aspects of an elastic solid with features resembling viscous fluids, and are therefore known as *viscoelastic*.

On dealing with a viscoelastic material it is reasonable to consider separately the purely elastic behaviour and the additional viscous behaviour, thus implying that the total stress σ needed to develop a given strain ϵ is the sum of a purely elastic term $\sigma_0 = E_0\epsilon_0$ and a viscoelastic term σ_1 :

$$\sigma = \sigma_0 + \sigma_1 \quad (2)$$

Both stress terms are assumed to correspond to the same strain ($\epsilon = \epsilon_0 = \epsilon_1$). However, the strain, ϵ_1 , corresponding to the viscoelastic term is usually modelled as the sum of a purely elastic strain, $\epsilon_1^e = \sigma_1/E_1$, with a purely viscous strain, ϵ_1^v , (both subject to the same stress $\sigma_1 = \sigma_1^e = \sigma_1^v$):

$$\epsilon_1 = \epsilon_1^e + \epsilon_1^v \quad (3)$$

Experiment

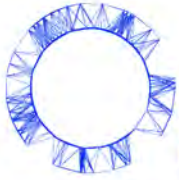

IPhO 2018
Lisbon, Portugal

Q2-2

English (Official)

In the purely viscous process, a linear relation between the stress and the time derivative of the strain is admitted (similarly to that found in viscous fluids),

$$\sigma_1 = \eta_1 \frac{d\epsilon_1^v}{dt},$$

where η_1 is the viscosity coefficient.

This phenomenological model is the so called *standard linear solid model* of linear viscoelasticity, and is depicted in Figure 1, where the springs represent pure elastic components and the pot represents the purely viscous component.

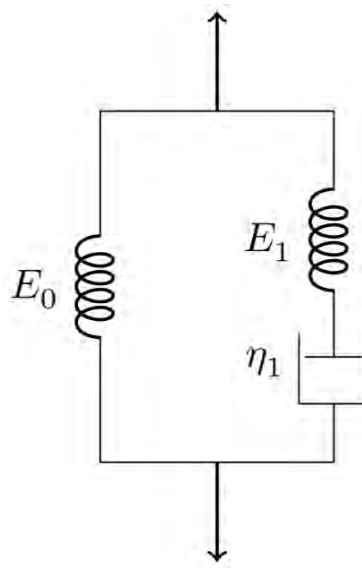

Figure 1. Standard linear solid model of linear viscoelasticity.

From the above equations the following relation is obtained:

$$\frac{d\epsilon_1}{dt} = \frac{1}{E_1} \frac{d\sigma_1}{dt} + \frac{\sigma_1}{\eta_1} \quad (4)$$

Therefore, within the standard linear model of viscoelasticity, it is possible to show that

$$\sigma = E_0 \epsilon + \tau_1 (E_0 + E_1) \frac{d\epsilon}{dt} - \tau_1 \frac{d\sigma}{dt} \quad (5)$$

where $\tau_1 = \eta_1/E_1$. This differential equation shows that the relation between the strain and the stress is no longer linear, and that the strain and the stress are both in general functions of time. To get $\epsilon(t)$ it is necessary to specify the function $\sigma(t)$, and vice-versa.

There are two special cases of practical interest, in which either $d\epsilon/dt = 0$ or $d\sigma/dt = 0$, commonly known as the *stress relaxation conditions* and the *creep conditions*, respectively. Under the stress relaxation conditions, a sudden strain ϵ is applied to the material, which is kept constant over time, so that $d\epsilon/dt = 0$.

Experiment

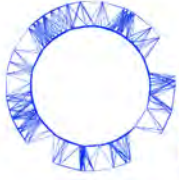

IPhO 2018
Lisbon, Portugal

Q2-3

English (Official)

In such a case, the function $\sigma(t)$ is then dependent only on the viscoelastic parameters of the medium and the solution of eq. (5) is

$$\sigma(t) = \epsilon(E_0 + E_1 e^{-t/\tau_1}) \quad (6)$$

where it was admitted that at $t = 0$ only the elastic components contribute to the stress and thus

$\sigma(t = 0) = \epsilon(E_0 + E_1)$. This solution shows that the viscoelastic stress decays exponentially with time, with a time constant τ_1 .

Multi-viscoelastic processes

The standard linear model can be readily extended to include many viscoelastic processes, as suggested by Figure 2.

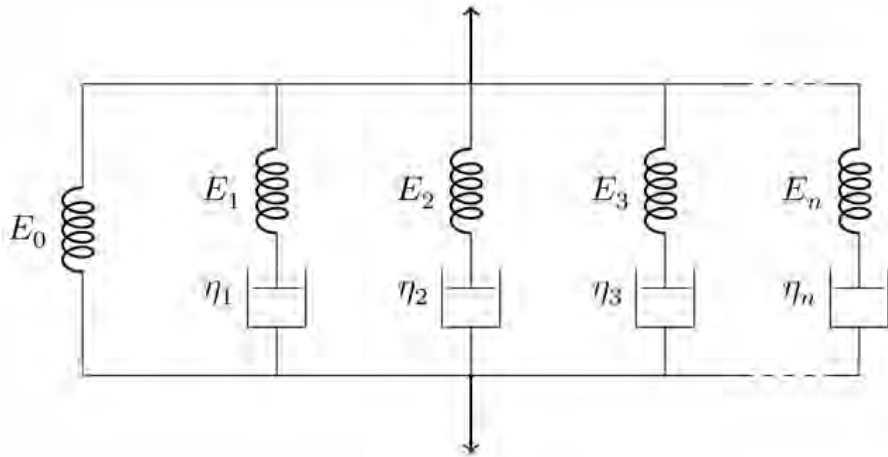

Figure 2. Generalised model for multi-viscoelastic processes.

Thus, considering N different viscoelastic components,

$$\sigma = \sigma_0 + \sum_k \sigma_k, \quad k = 1, 2, \dots, N \quad (7)$$

where $\frac{d\epsilon_k}{dt} = \frac{1}{E_k} \frac{d\sigma_k}{dt} + \frac{\sigma_k}{\eta_k}$, and as above, $\frac{d\epsilon_0}{dt} = \frac{d\epsilon_k}{dt} = \frac{d\epsilon}{dt}$.

The following generalization of eq. (5) is thus applicable:

$$\sigma = E_0 \epsilon + \eta_t \frac{d\epsilon}{dt} - \sum_k \tau_k \frac{d\sigma_k}{dt}, \quad k = 1, 2, \dots, N \quad (8)$$

where $\eta_t = \sum_k \eta_k$, and $\tau_k = \eta_k / E_k$.

Experiment

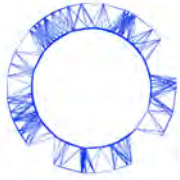

IPhO 2018
Lisbon, Portugal

Q2-4

English (Official)

In constant strain conditions, the various viscoelastic stresses should still decay exponentially with time, $\sigma_k = A_k e^{-t/\tau_k}$, leading to the solution:

$$\sigma(t) = \epsilon \left(E_0 + \sum_k E_k e^{-t/\tau_k} \right), \quad k = 1, 2, \dots, N \quad (9)$$

where it was assumed that at $t = 0$ only the elastic components contribute to the total stress and thus $\sigma_0 = \epsilon(E_0 + \sum_k E_k)$. The resulting viscoelastic response is evidently non-linear.

Experiment

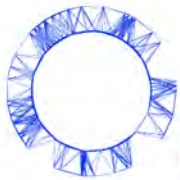

IPhO 2018
Lisbon, Portugal

Q2-5

English (Official)

Equipment

The following set of equipments is provided for this experimental problem (see Figure 3):

1. 1 standing structure, with a supporting system to position a laser pointer and another upper supporting system to hold the thread stretched vertically with constant strain above the scale;
2. 1 mass-set, consisting of a hollow cylindrical mass and a holding screw to attach the thread;
3. 1 long thermoplastic polyurethane (TPU) thread attached to the mass-set and to another holding screw used to hang the thread from the upper support;
4. 1 short TPU thread attached to a single holding screw;
5. 1 laser pointer and the respective support;
6. 1 digital scale;
7. 2 plane mirrors;
8. 1 stopwatch;
9. 1 ruler;
10. 1 metallic measuring tape;
11. 1 sheet of A4 paper to act as a screen;
12. 1 spring clamp to hold the laser in place and to switch it on.

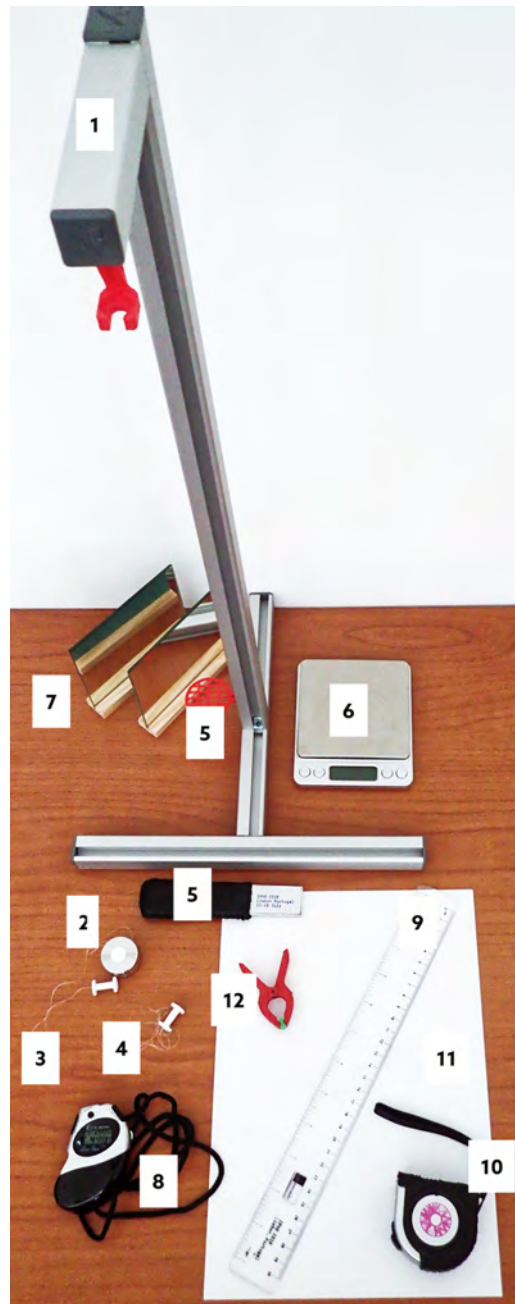
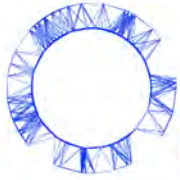
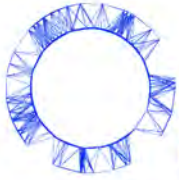

Figure 3. Equipment for this experimental problem.

Experiment



IPhO 2018
Lisbon, Portugal

Q2-7

English (Official)

Part A: Stress-relaxation measurements (1.9 points)

Please note that the thread must not be stressed before the beginning of the experiment! In case the thread is inadvertently stressed, ask for a spare one, but be reminded that this will take some time, therefore reducing the time you have for your experiment.

You should read carefully the indications given on "Part D: Data Analysis" before starting the measurements on this part in order to plan the way you make the measurements.

A.1 Measure the length of the unstretched thread between the screw heads. To obtain the total thread length, ℓ_0 , including the length inside the screws, add 5 mm for each screw. Write down in the answer sheet the measured value of ℓ_0 and its uncertainty. 0.3pt

A.2 Measure the total weight of the mass-set, P_0 , in gram-force (gf) units. Remember that 1 gram-force is the force corresponding to the weight of a mass of 1 gram ($1 \text{ gf} = 9.80 \times 10^{-3} \text{ N}$). Write down in the answer sheet the measured value and an estimation of its uncertainty. 0.3pt

To observe experimentally the various relaxation components it is necessary to measure the stress for a long enough time. In this case, it is sufficient to sample the stress evolution during about **45 minutes**.

You should now perform two simultaneous actions 1. and 2. Please read the instructions carefully before starting.

Important: if the experiment is interrupted for any reason it cannot be resumed. It has to be restarted with a new thread. In such case, ask for a spare one.

Take the following simultaneous actions:

1. Keeping the mass-set on the scale platform, stretch the thread so that the holding screw at the opposite side is placed on the thread supporting system, at the standing structure (Figure 4).
2. Start the chronometer simultaneously with action 1.

Experiment



IPhO 2018
Lisbon, Portugal

Q2-8

English (Official)



Figure 4. Hanging the thread on the support and starting the measurements.

A.3 Record the readings of the scale, $P(t)$, and the corresponding reading instant, t , during around 45 min, in the table provided in the answer sheet. 1.0pt

A.4 Measure the length of the stretched thread, ℓ , and estimate the corresponding uncertainty. Write down in the answer sheet the measured value of ℓ and its uncertainty. 0.3pt

Part B: Measurement of the stretched thread diameter (1.5 points)

**Never look directly at the laser! When not in use, the laser pointer should be off.
If you have difficulties in getting a diffraction pattern, please ask for a new laser.**

In this part you will use light diffraction to measure the diameter of the polymer thread. The nominal diameter of the unstretched thread is 0.5 mm. As you may know, the diffraction pattern of a rectangular slit of width d is similar to that of a cylindrical object with the same diameter d as the slit width. In the far-field (Fraunhofer) regime, where the diffraction pattern is observed in a target screen placed at a distance much larger than the diameter of the object, the distance between the diffraction minima for small angles is the same for both the slit and the object and is given by

$$d \sin \theta = n\lambda, \quad n = 1, 2, 3, \dots, \quad (10)$$

where θ is the diffraction angle.

You will use laser light with a wavelength $\lambda = 650 \pm 10$ nm.

To perform this part, proceed as follows:

1. Turn on the laser using the spring clamp (see Figure 5).
2. Position the laser so that it hits the stretched thread directly.

Experiment



IPhO 2018
Lisbon, Portugal

Q2-9

English (Official)

3. With the provided material, devise a method to project the diffraction pattern into a paper screen, and to measure the data needed to determine the diameter of the thread using eq. (10).



Figure 5. Turning on the laser using the spring clamp.

B.1	Make a sketch of your method in the answer sheet.	0.6pt
B.2	Measure the optical distance, D , between the thread and the projected diffraction pattern. Write it down in the answer sheet with an estimation of its uncertainty.	0.3pt
B.3	Determine the average distance, \bar{x} , between diffraction minima and its uncertainty. Write it down in the answer sheet with an estimation of its uncertainty.	0.3pt
B.4	Applying eq. (10) to your diffraction data, determine the diameter, d , of the stretched polymer thread and its uncertainty. Write it down in the answer sheet with an estimation of its uncertainty.	0.3pt

Part C: Changing to a new thread (0.3 points)

Before proceeding with the data analysis (**Part D**) you have to prepare the setup for the measurement with the shorter thread (**Part E**).

Detach the mass-set from the long thread (unscrewing it) and transfer it to the free end of the shorter thread (inserting the thread through the hole and fixing it with the screw-thread, see Figure 6).

In case you are unable to insert the thread through the hole, please ask for help.

Experiment



IPhO 2018
Lisbon, Portugal

Q2-10

English (Official)



Figure 6. Mounting the TPU thread on the holding screw.

- C.1** Measure the length, ℓ'_0 of the thread as in **A.1**. Write it down in the answer sheet with an estimation of its uncertainty. 0.3pt

Hang this new thread on the upper support so that the mass will exert a constant stress. The thread will eventually reach the stationary strain $\epsilon = \sigma/E$, while you work out the data analysis (**it should be suspended for at least 30 minutes**).

Part D: Data analysis (5.7 points)

N.B.: The acceleration of gravity in Lisbon is $g = 9.80 \text{ ms}^{-2}$.

- D.1** Calculate the force on the thread, F , in gf, for all data points and fill the corresponding column in the table used in **A.3**. 0.3pt

- D.2** Plot $F(t)$ in the graph paper provided in the answer sheet. 0.4pt

Since the scale platform does not move, the measurements can be considered at constant strain and eq. (9) can be used. The ratio $\frac{\sigma}{\epsilon}$ can be written as $\frac{\sigma}{\epsilon} = \beta F$, where β is a constant. Therefore,

$$\frac{\sigma}{\epsilon} = \beta F(t) = E_0 + E_1 e^{-t/\tau_1} + E_2 e^{-t/\tau_2} + E_3 e^{-t/\tau_3} + \dots \quad (11)$$

where the sum was ordered ($\tau_1 > \tau_2 > \tau_3 > \dots$) for convenience.

- D.3** Determine the constant strain, ϵ , and the corresponding uncertainty. Write it down in the answer sheet with an estimation of its uncertainty. 0.3pt

- D.4** Calculate the factor β , with σ in SI units and F in gf units. Write it down in the answer sheet (no uncertainty required). 0.3pt

- D.5** Look at the data in the graph used in **D.2**: it cannot be explained by a purely elastic process. Sketch qualitatively in the graph paper provided in the answer sheet what you would expect for $F(t)$ in the purely elastic case. 0.4pt

The data analysis is easier if we consider $\frac{dF}{dt}$ instead of $F(t)$. This means that the relaxation parameters can then be extracted by hand in successive steps. In order to do this, the time derivative $\frac{dF}{dt}$ should be

Experiment

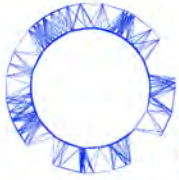

IPhO 2018
Lisbon, Portugal

Q2-11

English (Official)

calculated at every point. This can be done either graphically or numerically. In the simpler case where the data points are taken at equal intervals, the numerical value of the derivative of a function $f(t)$ at point t_i , in a data set $(t_1, f_1), (t_2, f_2), (t_3, f_3), \dots$, is approximately given by

$$\left. \frac{df}{dt} \right|_i = \frac{f_{i+1} - f_{i-1}}{2h} \quad i = 2, \dots, N - 1 \quad (12)$$

where h is the (constant) interval between the points and N is the number of points.

If the intervals between data points are not equal, the numerical value of the derivative is approximately given by:

$$\left. \frac{df}{dt} \right|_i = \frac{h_-^2 f_{i+1} - h_+^2 f_{i-1} + (h_+^2 - h_-^2) f_i}{h_+^2 h_- + h_+ h_-^2} \quad i = 2, \dots, N - 1 \quad (13)$$

where $h_+ = (t_{i+1} - t_i)$ and $h_- = (t_i - t_{i-1})$ and N is the number of data points. This expression represents the average derivative at left and right, weighted by the inverse time interval.

To analyse the data and extract the relevant parameters it is necessary to follow a sequence of steps. Hence, given the ordered sum in equation (11), do the following:

D.6 Assume that your data set lasts for longer than τ_2 and calculate the derivative, $\frac{dF}{dt}$, for data points at times $t > 1000$ s. Register the values in the table used in **A.3**. In case you use a graphical method for calculating $\frac{dF}{dt}$, use the graph paper provided in the answer sheet. 0.5pt

D.7 In the answer sheet, write an expression for the expected time dependence of $\frac{dF}{dt}$ in the case of a single viscoelastic process. 0.3pt

D.8 Extract, using a graphical method, the parameters E_1 and τ_1 in SI units from the data points referred in **D.6**. Write E_1 and τ_1 in the answer sheet (no uncertainties required). 1.0pt

D.9 Extract the parameter E_0 in SI units from the data points referred in **D.6**. Write it down in the answer sheet (no uncertainty required). 0.3pt

D.10 Fill column $y(t)$ in the table used in **A.3** by subtracting the elastic and the longest viscoelastic components from $F(t)$ (the points used in **D.6** do not need to be considered here). 0.3pt

D.11 Extract from $y(t)$ (see **D.10**), using a graphical method, the parameters for the second viscoelastic component, E_2 and τ_2 , in SI units. Write E_2 and τ_2 in the answer sheet (no uncertainties required). 1.0pt

Additional viscoelastic components can be extracted in a similar way.

Experiment

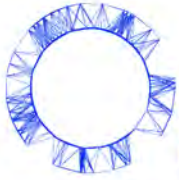

IPhO 2018
Lisbon, Portugal

Q2-12

English (Official)

D.12 Identify the time window $[t_i, t_f]$ relevant for the third component. Write t_i and t_f in the answer sheet (no uncertainties required). 0.3pt

D.13 Estimate τ_3 in SI units from the graph in **D.11**. Write it down in the answer sheet (no uncertainty required). 0.3pt

Part E: Measuring E in constant stress conditions (0.6 points)

Go back to the shorter thread suspended in **Part C**. Make sure that at least 30 minutes have passed since the thread was suspended. You can now safely assume that this thread has reached the stationary value of the strain $\epsilon = \sigma/E$.

E.1 Determine E directly from the length of the stretched thread. Write it down in the answer sheet, together with the relative difference to the value E_0 obtained in **Part D** (no uncertainties required). 0.6pt

IPhO 2018
Lisbon, Portugal

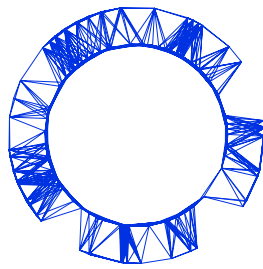

Solutions to Experimental Problem 1

Paper transistor

(Elvira Fortunato, Luís Pereira, Rui Igreja, Paul Grey, Inês Cunha, Diana Gaspar, Rodrigo Martins)

July 23, 2018

v1.4

Confidential

Sketch of the solutions:

Part A. Circuit dimensioning (2.4 points)

A.1

Using Ohm's law, the current through the voltage divisor is $I = V_{\text{in}} / (R_x + R_y)$, and $V_{\text{out}} = R_y I$. Thus

A.1

$$V_{\text{out}} = V_{\text{in}} \frac{R_y}{R_x + R_y}$$

0.2pt

A.2

A.2 Uncertainty in each measurement: $\pm 0.01 \Omega$

0.5pt

#	R_{T1}	R_{T2}	R_{T3}
1	122.3	125.3	125.3
2	122.3	125.4	125.4
3	122.3	125.3	125.4
4	122.2	125.2	125.5
5	122.3	125.4	125.4
6	122.3	125.4	125.3
7	122.2	125.4	125.4
8	122.2	125.3	125.4
9	122.2	125.4	125.4
10	122.2	125.4	125.5
\bar{R}	122.25	125.35	125.40
σ_R	0.05	0.07	0.07

A.3

- A.3** For a parallelepiped conductor of length l , width w and thickness t , the resistance is given by 0.3pt

$$R = \rho \frac{l}{wt}$$

For a thin film of square shape, $l = w$, thus

$$R = \rho \frac{l}{t \cancel{w}} = \frac{\rho}{t} = R_{\square}.$$

A.4

The weighted average value (weighed by $1/\sigma^2$) of the sheet resistance is $\bar{R} = 123.94 \pm 0.04 \Omega$ and $\rho = R_{\square} t$.

- A.4** $\bar{R} = 123.94 \pm 0.04 \Omega$
 $\rho = 2.5 \pm 0.1 \times 10^{-3} \Omega \text{ m}.$ 0.4pt

A.5

- A.5** For a rectangular thin film $R = R_{\square} \frac{l}{w}$, thus 0.5pt

$$R_1 = R_2 = R_{\square} (1 + 1/0.9 + 1/0.8 + 1/0.7 + 1/0.6 + 1/0.5 + 1/0.4 + 1/0.3) = 14.2897 R_{\square}$$

Measured values:

$$R_1 = 1776 \pm 1 \Omega \quad k_1 = 14.33$$

$$R_2 = 1787 \pm 1 \Omega \quad k_2 = 14.42$$

$$\bar{k} = 14.3 \pm 0.1$$

Comparison with the theoretical value: the average value is compatible, within the assigned error bar, with the theoretical value.

A.6

A.6 Uncertainty in resistance measurements: $\pm 1 \Omega$.

0.3pt

Resistor R_1 :

Points	R_x/Ω	R_y/Ω
Z	1776	0
A	1708	165
B	1578	296
C	1421	452
D	1239	607
E	1033	829
F	768	1072
G	439	1394
V	0	1782

Resistor R_2 :

Points	R_x/Ω	R_y/Ω
Z	1791	0
H	1428	411
I	1120	737
J	882	996
K	670	1200
L	498	1396
M	341	1555
N	188	1719
W	0	1793

A.7

A.7

0.3pt

Points	V_{out}/V	Points	V_{out}/V
Z	0	-	—
A	-0.208	H	0.664
B	-0.435	I	1.171
C	-0.699	J	1.593
D	-1.003	K	1.939
E	-1.337	L	2.24
F	-1.756	M	2.51
G	-2.29	N	2.77
V	-2.99	W	3.00

Part B. Characteristic Curves of the JFET transistor (4.5 points)

B.1

B.1 $I_{\text{DS}} = 11.84 \pm 0.01 \text{ mA}$

0.2pt

B.2

Gate/Drain	Z	H	I	J	K	L	M	N	W
Z	0	1.58	2.18	2.82	3.60	4.75	6.45	9.43	11.87
A	0	1.52	2.13	2.67	3.47	4.53	6.04	7.82	8.78
B	0	1.45	2.00	2.63	3.29	4.21	5.15	5.77	6.09
C	0	1.28	1.79	2.23	2.59	2.85	2.99	3.08	3.16
D	0	0.65	0.76	0.81	0.85	0.89	0.92	0.94	0.96
E	0	0.03	0.04	0.05	0.05	0.05	0.05	0.06	0.07
F	0	0	0	0	0	0	0	0	0
G	0	0	0	0	0	0	0	0	0
V	0	0	0	0	0	0	0	0	0

B.3

The unloaded voltage is

$$V_{\text{out}} = V_{\text{in}} \frac{R_y}{R_x + R_y}$$

and the loaded voltage is

$$V_{\text{out}}^{\text{L}} = V_{\text{in}} \frac{R'_y}{R_x + R'_y},$$

where R'_y is the equivalent resistance of the parallel association between R_y and R_L :

$$R'_y = \frac{R_y R_L}{R_y + R_L}.$$

Thus,

$$f = \frac{\frac{R'_y}{R_x + R'_y}}{\frac{R_y}{R_x + R_y}} = \frac{(R_x + R_y) R'_y}{(R_x + R'_y) R_y} = \frac{(R_x + R_y) \frac{R_L}{R_y + R_L}}{R_x + R_y \frac{R_L}{R_y + R_L}}$$

Note that in terms of $\eta = 1/(1 + \frac{R_y}{R_L})$, the factor f can be written as

$$f = \frac{(R_x + R_y) \eta}{R_x + R_y \eta}$$

When $R_L \gg R_y$, $\eta \rightarrow 1$, and $f \rightarrow 1$; when $R_L \ll R_y$, $\eta \rightarrow 0$ and $f \rightarrow 0$.

B.3

$$f = \frac{(R_x + R_y)\eta}{R_x + R_y\eta}$$

0.2pt

B.4

B.4

Gate: A $V_{GS} = 0 \text{ V}$ $R_{DS} = 50.0$

0.7pt

Drain	V_{out}/V	V_{out}^L/V	V_{DS}/V	I_{DS}/mA	rI/V	f
Z	0,000	0,000	0,000	0,00	0,000	1,000
H	0,664	0,105	0,089	1,58	0,016	0,158
I	1,171	0,139	0,117	2,18	0,022	0,119
J	1,593	0,181	0,153	2,82	0,028	0,114
K	1,939	0,237	0,201	3,60	0,036	0,122
L	2,240	0,315	0,267	4,75	0,048	0,140
M	2,510	0,443	0,379	6,45	0,065	0,177
N	2,770	0,724	0,630	9,43	0,094	0,261
W	3,000	3,000	2,881	11,87	0,119	1,000

B.4
cont.

0.7pt

Gate: B $V_{GS} = -0.208 \text{ V}$ $R_{DS} = 58.73$

Drain	V_{out}/V	V_{out}^L/V	V_{DS}/V	I_{DS}/mA	rI/V	f
Z	0.000	0.000	0.000	0.00	0.000	1.000
H	0.664	0.118	0.102	1.52	0.015	0.177
I	1.171	0.157	0.136	2.13	0.021	0.134
J	1.593	0.204	0.177	2.67	0.027	0.128
K	1.939	0.267	0.233	3.47	0.035	0.138
L	2.240	0.353	0.308	4.53	0.045	0.158
M	2.510	0.495	0.435	6.04	0.060	0.197
N	2.770	0.799	0.721	7.82	0.078	0.289
W	3.000	3.000	2.912	8.78	0.088	1.000

Gate: C $V_{GS} = -0.435 \text{ V}$ $R_{DS} = 72.54$

Drain	V_{out}/V	V_{out}^L/V	V_{DS}/V	I_{DS}/mA	rI/V	f
Z	0.000	0.000	0.000	0.00	0.000	1.000
H	0.664	0.136	0.122	1.45	0.015	0.205
I	1.171	0.183	0.163	2.00	0.020	0.157
J	1.593	0.239	0.213	2.63	0.026	0.150
K	1.939	0.312	0.279	3.29	0.033	0.161
L	2.240	0.411	0.369	4.21	0.042	0.184
M	2.510	0.572	0.520	5.15	0.052	0.228
N	2.770	0.907	0.850	5.77	0.058	0.328
W	3.000	3.000	2.939	6.09	0.061	1.000

B.4
cont.

0.7pt

Gate: D $V_{GS} = -0.699 \text{ V}$ $R_{DS} = 99.86$

Drain	V_{out}/V	V_{out}^L/V	V_{DS}/V	I_{DS}/mA	rI/V	f
Z	0.000	0.000	0.000	0.00	0.000	1.000
H	0.664	0.170	0.157	1.28	0.013	0.256
I	1.171	0.232	0.214	1.79	0.018	0.198
J	1.593	0.303	0.281	2.23	0.022	0.190
K	1.939	0.395	0.369	2.59	0.026	0.204
L	2.240	0.516	0.487	2.85	0.029	0.230
M	2.510	0.708	0.678	2.99	0.030	0.282
N	2.770	1.089	1.059	3.08	0.031	0.393
W	3.000	3.000	2.968	3.16	0.032	1.000

Gate: E $V_{GS} = -1.003 \text{ V}$ $R_{DS} = 176.3$

Drain	V_{out}/V	V_{out}^L/V	V_{DS}/V	I_{DS}/mA	rI/V	f
Z	0.000	0.000	0.000	0.00	0.000	1.000
H	0.664	0.245	0.238	0.65	0.007	0.369
I	1.171	0.346	0.338	0.76	0.008	0.295
J	1.593	0.454	0.446	0.81	0.008	0.285
K	1.939	0.586	0.578	0.85	0.009	0.302
L	2.240	0.754	0.745	0.89	0.009	0.337
M	2.510	1.004	0.994	0.92	0.009	0.400
N	2.770	1.451	1.441	0.94	0.009	0.524
W	3.000	3.000	2.990	0.96	0.010	1.000

B.4
cont.

1.2pt

Gate: F $V_{GS} = -1.337 \text{ V}$ $R_{DS} = 1111$

Drain	V_{out}/V	V_{out}^L/V	V_{DS}/V	I_{DS}/mA	rI/V	f
Z	0.000	0.000	0.000	0.00	0.000	1.000
H	0.664	0.526	0.523	0.03	0.003	0.791
I	1.171	0.857	0.853	0.04	0.004	0.732
J	1.593	1.149	1.144	0.05	0.005	0.721
K	1.939	1.431	1.426	0.05	0.005	0.738
L	2.240	1.719	1.714	0.05	0.005	0.767
M	2.510	2.039	2.034	0.05	0.005	0.812
N	2.770	2.430	2.424	0.06	0.006	0.877
W	3.000	3.000	2.993	0.07	0.007	1.000

Gate: G $V_{GS} = -1.756 \text{ V}$ $R_{DS} = \infty$

Drain	V_{out}/V	V_{out}^L/V	V_{DS}/V	I_{DS}/mA	rI/V	f
Z	0.000	0.000	0.000	0.00	0.000	1.000
H	0.664	-0.288	-0.288	0.00	0.000	-0.434
I	1.171	-0.325	-0.325	0.00	0.000	-0.278
J	1.593	-0.415	-0.415	0.00	0.000	-0.260
K	1.939	-0.562	-0.562	0.00	0.000	-0.290
L	2.240	-0.800	-0.800	0.00	0.000	-0.357
M	2.510	-1.325	-1.325	0.00	0.000	-0.528
N	2.770	-3.675	-3.675	0.00	0.000	-1.327
W	3.000	3.000	3.000	0.00	0.000	1.000

B.5

B.5 Output curves:

0.5pt

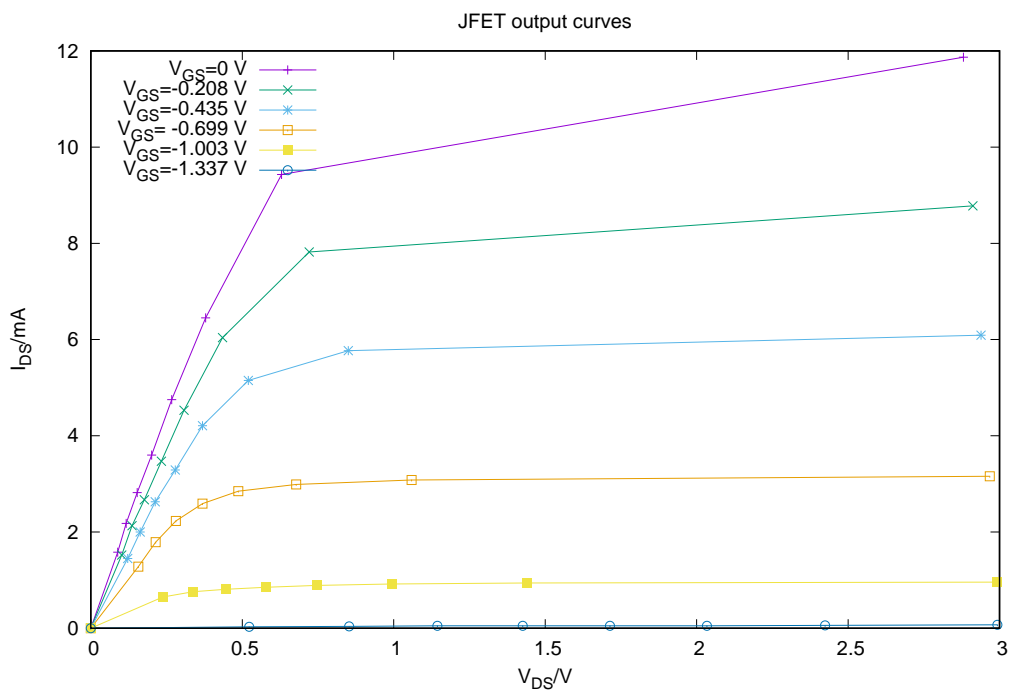

Confidential

B.6

The R_{DS} values are obtained from the slopes of the linear region of the output curves (small V_{DS} voltages).

The last point in the plot $R_{DS}(V_{GS})$ has a large error bars as we are missing points in the linear regime, and will be ignored.

The solid line in the plot is the result of a fit to $R_{DS} = R_{DS}^0 (1 - V_{GS}/V_P)$, that gave $R_{DS}^0 = 52(2) \Omega$, $V_P = -1.18(1) \text{ V}$.

B.6

0.5pt

V_{GS}/V	R_{DS}/Ω
0	56.5 ± 2
-0.208	67.4 ± 2
-0.435	84.1 ± 4
-0.699	122.84 ± 4
-1.003	366.6 ± 4
-1.337	1111 ± 100

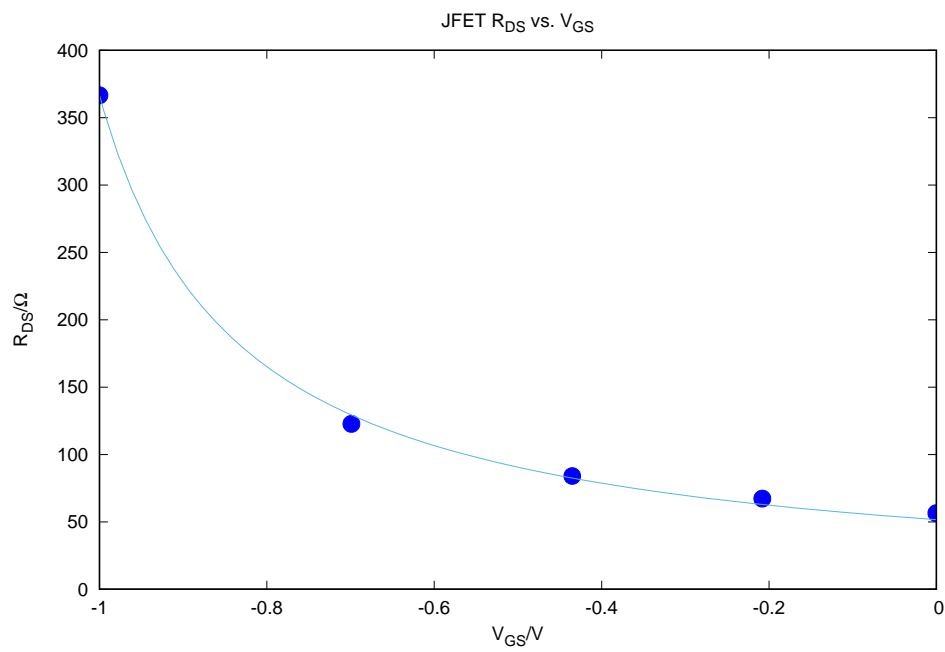

Confidential

B.7

The data was obtained with $V_{DS} = +3$ V. The solid line is the result of the fit to the data of the function

$$I_{DS} = I_{DSS} (1 - V_{GS}/V_P)^2.$$

The fitted parameters are $I_{DSS} = 11.89 \pm 0.06$ mA and $V_P = -1.42 \pm 0.02$ V.

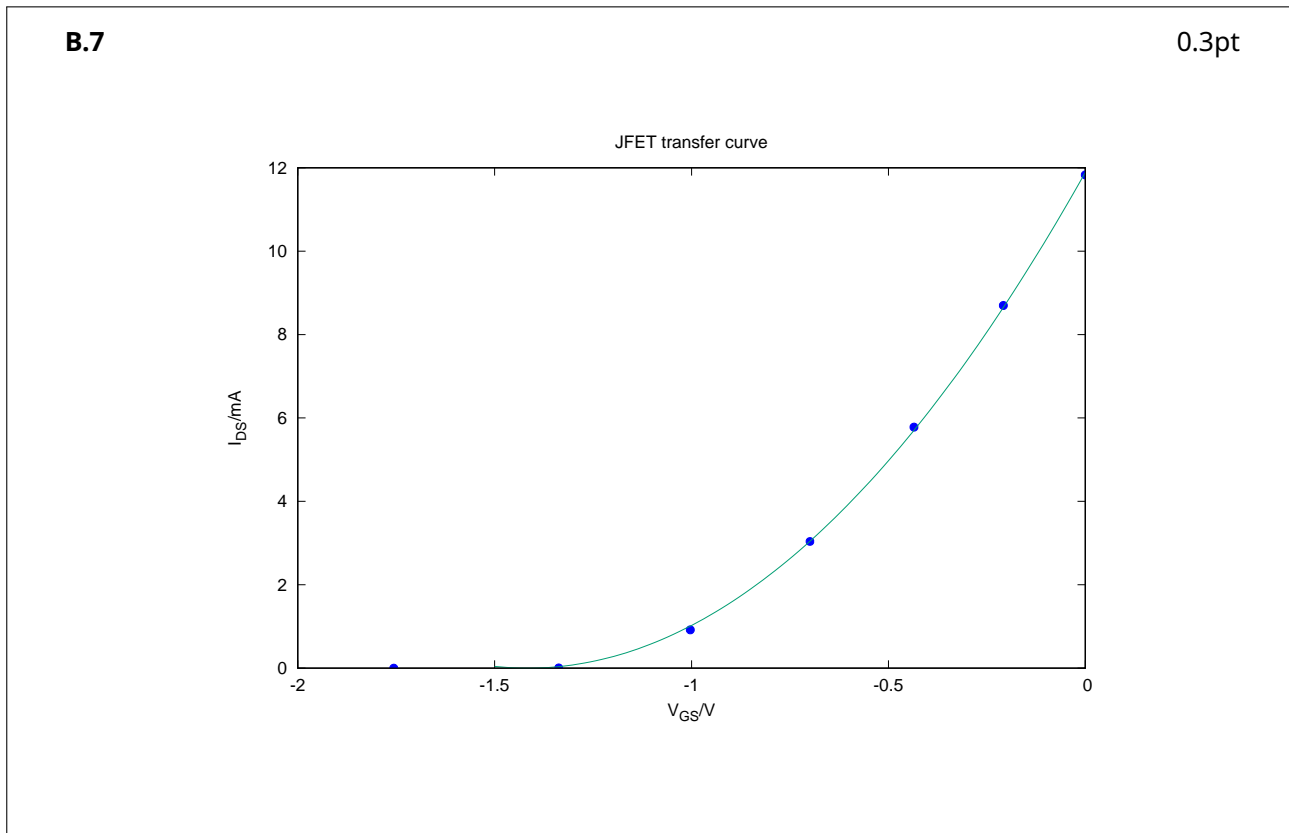

Confidential

B.8

From

$$I_{DS} = I_{DSS} (1 - V_{GS}/V_P)^2$$

a plot of $\sqrt{I_{DS}}$ as function of V_{GS} should yield a straight line with slope $a = -\sqrt{I_{DS}}/V_P$ that intercepts the x -axis at V_P .

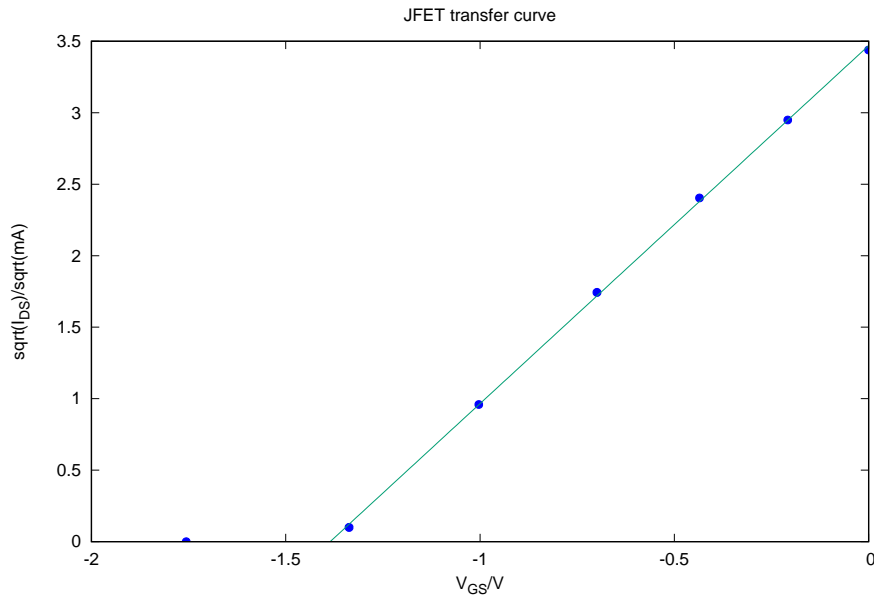

A linear fit to $f(x) = ax + b$ gave $a = 2.50(2)$ and $b = 3.47(2)$. Thus, $V_p = -b/a = -1.39(2)$ V and $I_{DSS} = 4.23^2 = 12.0(2)$ mA.

B.8 $V_p = -b/a = -1.39(2)$ V
 $I_{DSS} = 4.23^2 = 12.0(2)$ mA.

0.4pt

B.9

The transconductance is the slope of the transfer curve at a given point. From the transfer plot, we draw the tangent at the point with abscissa -0.50 V and read the slope from the graph, obtaining $g = 10.8(1)$ m⁻¹.

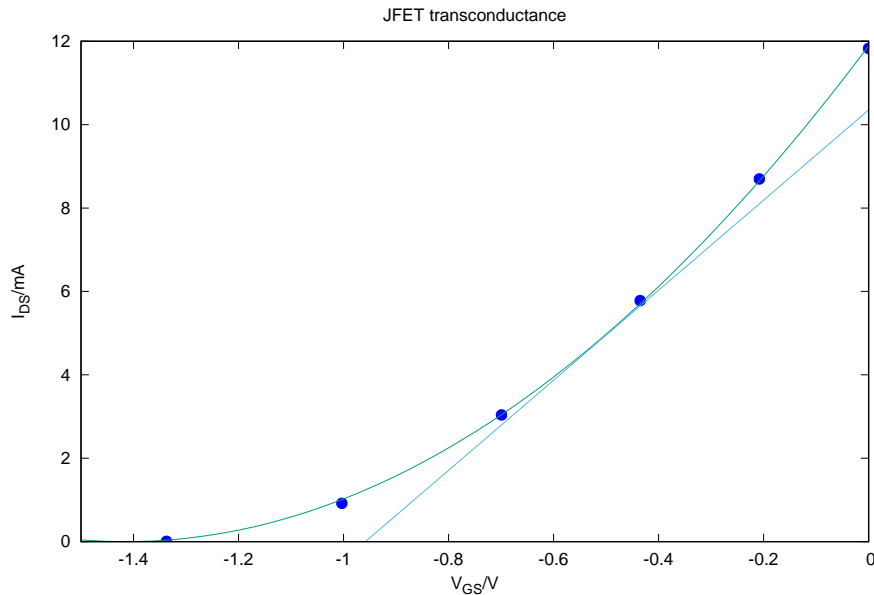

From

$$I_D = I_{DSS} (1 - V_{GS}/V_P)^2,$$

$$g = \frac{\partial I_{DS}}{\partial V_{GS}} = 2I_{DSS} (1 - V_{GS}/V_P) \left(-\frac{1}{V_P} \right) = \frac{2I_{DSS}}{V_P} (V_{GS}/V_P - 1).$$

Substituting values,

$$g = 10.8 \text{ m}^{-1}$$

a value that agrees with that obtained using the graphical method.

B.9 $g_{\text{measured}} = 10.8(1) \text{ m}^{-1}$
 $g_{\text{model}} = 10.8 \text{ m}^{-1}$

0.4pt

Part C: The Paper Thin Film Transistor (2.0 points)

C.1

C.1		0.8pt	
t/s	$I_{DS}/\mu A$	t/s	$I_{DS}/\mu A$
0	0	110	112,0
10	6.6	120	116.2
20	25.8	180	137.7
30	50.1	240	155.4
40	66.2	300	171.2
50	76.7	360	184.4
60	83.8	420	197.9
70	91.6	480	209.2
80	97.2	540	219.1
90	102.6	600	220.0
100	107.4	-	-

Confidential

C.2

The data is similar to that of the charge of a capacitor, superimposed with an almost linear component that corresponds to the charge of the second capacitor with a larger time constant.

A least squares fit to a $A(1 - \exp(-t/\tau_1)) + B(1 - \exp(-t/\tau_2))$ is also depicted, showing that the data can be well fitted by this model. The shorter time constant is $\tau_1 = 43(8)$ s, the longer time constant, τ_2 is roughly 20 times larger.

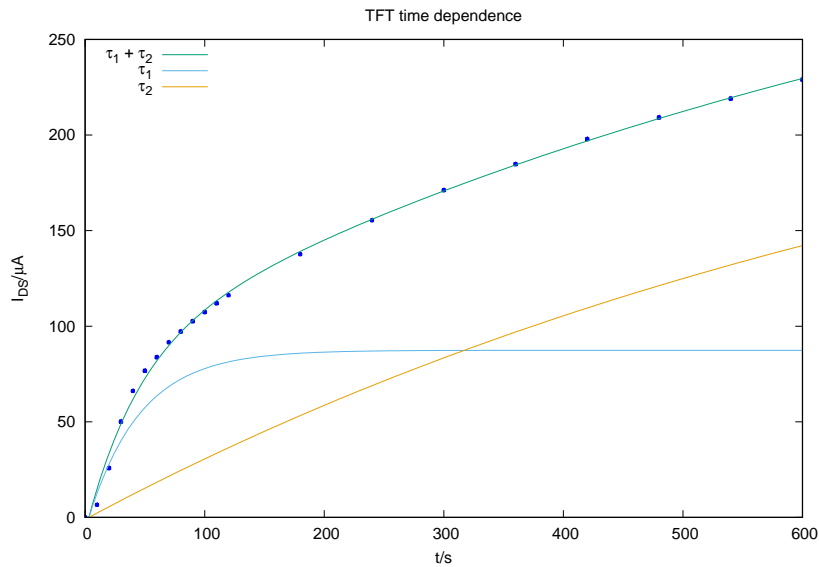

Let $I_{DS}^{\text{sub}} = A(1 - \exp(-t/\tau_1))$ be the data subtracted from the long time constant component. A logarithmic plot of $\log(A - I_{DS}^{\text{sub}})$ should be a straight line of slope $-1/\tau_1$. The constant A , the saturation current of the short τ_1 component, can be easily estimated from the above plot.

The slope of the line is $m = -0.023(1)$, from which we get $\tau_1 = 44(3)$ s. The error bar is underestimated, as it does not take into account the error in the subtraction of the τ_2 component.

C.2

1.2pt

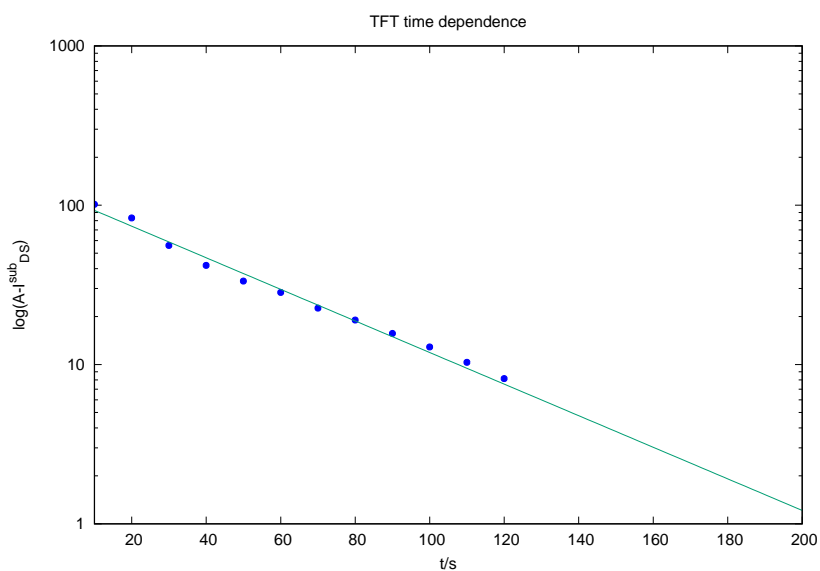
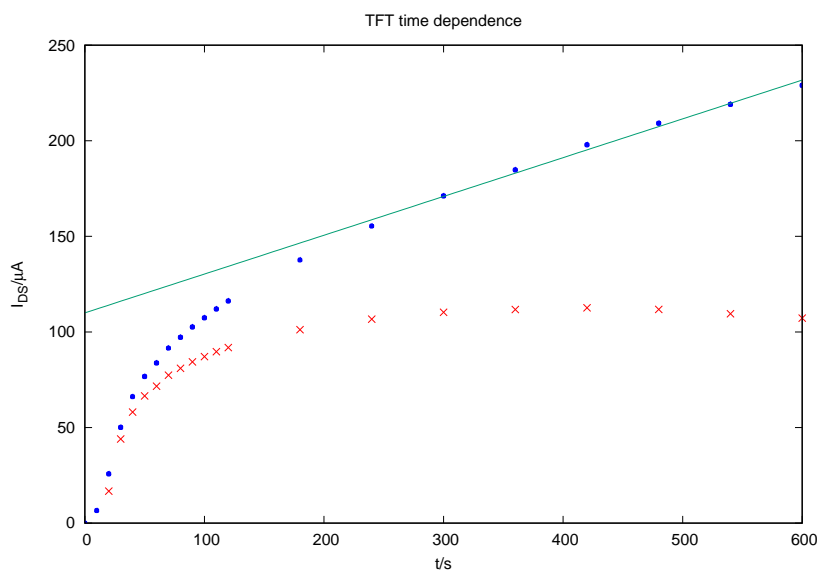

$$\tau_1 = 44(3) \text{ s.}$$

Part D. Inverter Circuit (1.0 points)

D.1

D.1 $R_L = 198 \text{ k}\Omega$

0.5pt

t	V_{in}/V	V_{out}/V
	-2.983	2.456
	-2.760	2.470
	-2.567	2.461
	-2.340	2.461
	-2.058	2.460
	-1.719	2.252
	-1.330	0.889
	-0.775	0.039

D.2

D.2

0.5pt

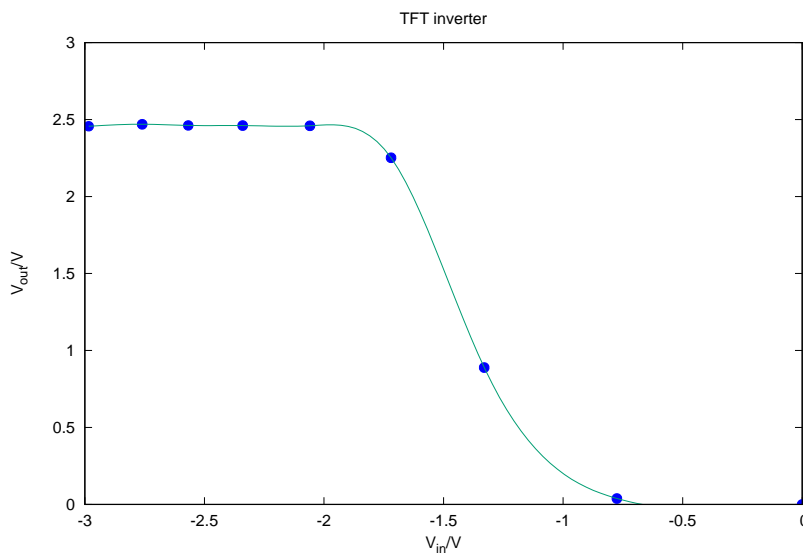

IPhO 2018
Lisbon, Portugal

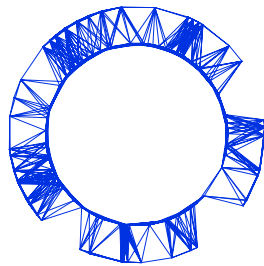

Solutions to Experimental Problem 2

Viscoelasticity of a polymer thread

(J. M. Gil, J. Pinto da Cunha, R. C. Vilão, H. V. Alberto)

July 22, 2018

v1.1

Confidential

Problem 2: Viscoelasticity of a polymer thread (10 points)

Part A. Stress-relaxation measurements (1.9 points)

A.1

Measurement: $\ell_0 = 42.7 + 2 \times 0.5 = 43.7 \text{ cm}$,

A.1	$\ell_0 = (43.7 \pm 0.2) \text{ cm}$.	0.3pt
------------	--	-------

A.2

A.2	$P_0 = (81.11 \pm 0.03) \text{ gf}$.	0.3pt
------------	---------------------------------------	-------

A.3

The table contains the readings on the scale P (Question A.3) and the force on the thread, $F(t)$, at constant strain (Question D.1). The values of $\frac{dF}{dt}$ (Question D.6) were computed numerically using equal time intervals. The function $y(t)$ is given by $y(t) = F(t) - F_0 - F_1 e^{-t/\tau_1}$ (Question D.10).

A.3	t / s	$P(t) / \text{gf}$	F / gf	$\frac{dF}{dt} / \text{gf s}^{-1}$	$y(t) / \text{gf}$	1.0pt
	10	35.7	45.41		2.82	
	17	36.2	44.91		2.33	
	26	36.6	44.51		1.95	
	32	36.8	44.31		1.76	
	40	37.0	44.11		1.57	
	46	37.1	44.01		1.48	
	51	37.2	43.91		1.38	
	58	37.3	43.81		1.29	
	65	37.4	43.71		1.20	

A.3

0.3pt

t/s	$P(t)/\text{gf}$	F/gf	$\frac{dF}{dt}/\text{gf s}^{-1}$	$y(t)/\text{gf}$
73	37.5	43.61		1.12
84	37.6	43.51		1.03
94	37.7	43.41		0.94
105	37.8	43.31		0.86
118	37.9	43.21		0.77
136	38.0	43.11		0.70
151	38.1	43.01		0.62
173	38.2	42.91		0.55
193	38.3	42.81		0.48
217	38.4	42.71		0.41
247	38.5	42.61		0.35
279	38.6	42.51		0.29
317	38.7	42.41		0.23
358	38.8	42.31		0.18
408	38.9	42.21		0.14
471	39.0	42.11		0.11
525	39.1	42.01		0.07
591	39.2	41.91		0.03
600	39.2	41.91		0.04
672	39.3	41.81		0.01
773	39.4	41.71		0.007
866	39.5	41.61		-0.01
900	39.52	41.59		-0.00
993	39.6	41.51		-0.01
1124	39.7	41.41		
1200	39.74	41.37	-7.00×10^{-4}	
1272	39.8	41.31		
1419	39.9	41.21		
1500	39.94	41.17	-5.33×10^{-4}	
1628	40.0	41.11		
1800	40.06	41.05	-4.67×10^{-4}	
1869	40.1	41.01		
2037	40.2	40.91		
2100	40.22	40.89	-3.83×10^{-4}	
2400	40.29	40.82		

A.4

Measurement: $\ell = 50.0 + 2 \times 0.5 = 51.0 \text{ cm}$,

A.4

$$\ell = (51.0 \pm 0.2) \text{ cm} .$$

0.3pt

Part B. Measurement of the stretched thread diameter (1.5 points)

B.1

Two mirrors are used to maximize the distance D and consequently the distance between diffraction minima.

B.1 Sketch of the method

0.6pt

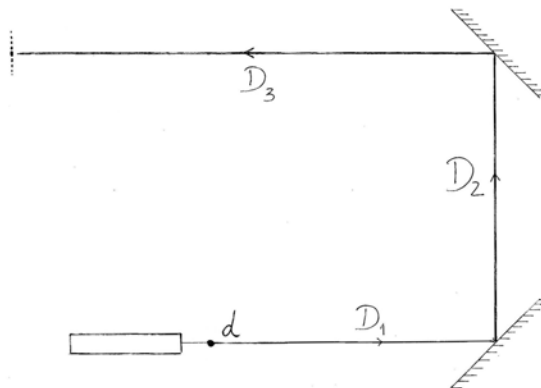

B.2

The total distance D is the sum

$$D = D_1 + D_2 + D_3 = (26.0 + 36.0 + 102.3) \text{ cm} = 164.3 \text{ cm} = 1.643 \text{ m} .$$

The estimated uncertainties are

$$\sigma_{D_1} = \sigma_{D_2} = \sigma_{D_3} \approx 0.5 \text{ cm} \Rightarrow \sigma_D = \sqrt{3 \times \sigma_{D_1}^2} = 0.5 \times \sqrt{3} = 0.87 \text{ cm} .$$

B.2

$$D = (1.643 \pm 0.009) \text{ m} .$$

0.3pt

B.3

The distance between minima, x , is quite small. To reduce the error, the total distance Nx , with $N = 22$, was measured:

$$22x = 49 \text{ mm} \Rightarrow \bar{x} = 2.227 \text{ mm} .$$

The corresponding uncertainty is

$$\sigma_{\bar{x}} = \frac{\sigma_{22x}}{22} = \frac{0.25 \text{ mm}}{22} = 0.011 \text{ mm} .$$

B.3

$$\bar{x} = (2.227 \pm 0.011) \text{ mm} .$$

0.3pt

B.4

Using previous results, we get

$$d = \frac{\lambda}{\sin \theta} \simeq \frac{\lambda D}{\bar{x}} = \frac{650 \times 10^{-9} \text{ m} \times 1.643 \text{ m}}{2.227 \times 10^{-3} \text{ m}} = 4.795 \times 10^{-4} \text{ m} = 0.480 \text{ mm} .$$

For the uncertainties, we have

$$\frac{\sigma_d}{d} = \frac{\sigma_\lambda}{\lambda} + \frac{\sigma_D}{D} + \frac{\sigma_{\bar{x}}}{\bar{x}} = \frac{10}{650} + \frac{0.0087}{1.643} + \frac{0.011}{2.227} = 0.02517 \Rightarrow \sigma_d = 0.02517 \times 0.480 \text{ mm} = 0.012 \text{ mm} .$$

B.4

$$d = (0.480 \pm 0.012) \text{ mm} .$$

0.3pt

Part C. Change to a new thread (0.3 points)

C.1

Measurement: $\ell'_0 = 31.6 + 2 \times 0.5 = 32.6 \text{ cm}$.

C.1

$$\ell'_0 = (32.6 \pm 0.2) \text{ cm} .$$

0.3pt

Part D. Data Analysis (5.7 points)

D.1

The force on the thread was calculated as $F(t) = (P_0 - P(t))$, in gram-force units.

D.1 See column $F(t)$ in the table in A.3.

0.3pt

D.2

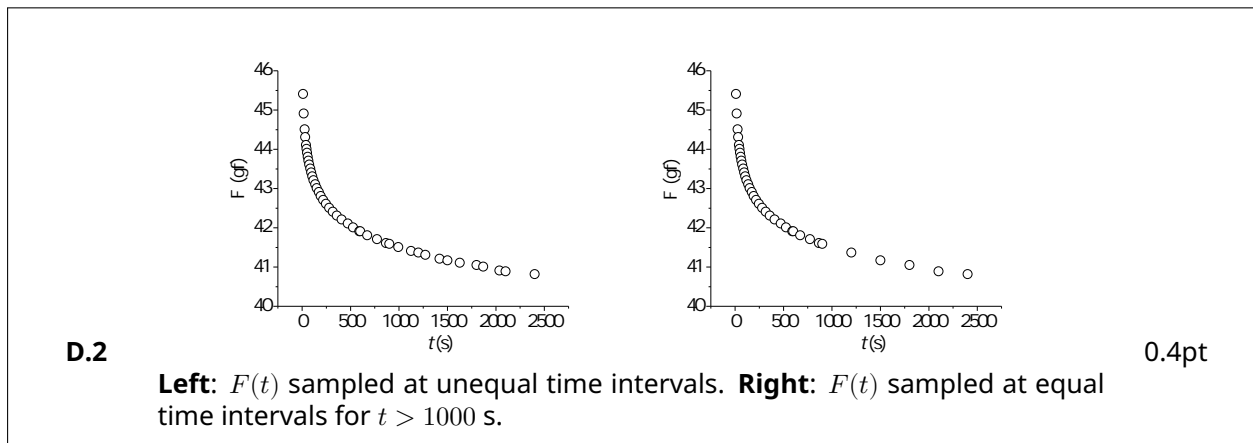

0.4pt

D.3

The dimensionless quantity ϵ is given by

$$\epsilon = \frac{l - l_0}{l_0} = \frac{51.0 - 43.7}{43.7} = 0.167 \text{ .}$$

The uncertainty in ϵ , σ_ϵ , is calculated propagating the uncertainties in the measured length, σ_l and σ_{l_0} :

$$\begin{aligned} \frac{\sigma_\epsilon}{\epsilon} &= \frac{\sigma_{(l-l_0)}}{l-l_0} + \frac{\sigma_{l_0}}{l_0} \\ &= \frac{\sqrt{\sigma_l^2 + \sigma_{l_0}^2}}{l-l_0} + \frac{\sigma_{l_0}}{l_0} \\ &= \frac{0.2 \times \sqrt{2}}{7.3} + \frac{0.2}{43.7} \\ &= 0.0433 \end{aligned}$$

Therefore, $\sigma_\epsilon = 0.0433 \times 0.167 = 0.0072$.

D.3

$$\epsilon = 0.167 \pm 0.007 \text{ .}$$

0.3pt

D.4

One has

$$\frac{\sigma}{\epsilon} = \frac{F}{\epsilon S}.$$

In this case, $S = \pi(d/2)^2 = 1.809 \times 10^{-7} \text{ m}^2$ and $\epsilon = 0.167$. We also have $1 \text{ gf} = g \times 10^{-3} \text{ N}$ with $g = 9.8 \text{ m s}^{-2}$. Therefore, if F is in gram-force units we have

$$\frac{\sigma}{\epsilon} = \frac{9.8 \times 10^{-3} \text{ gf}^{-1} \text{ N}}{0.167 \times 1.809 \times 10^{-7} \text{ m}^2} F = (324293 \text{ gf}^{-1} \text{ N m}^{-2}) F,$$

where F is in gf, and σ is in N m^{-2} . Comparing with $\frac{\sigma}{\epsilon} = \beta F$ we get

$$\beta = 324293 \text{ gf}^{-1} \text{ N m}^{-2}.$$

Note that, if we write

$$F(t) = F_0 + F_1 e^{-t/\tau_1} + F_2 e^{-t/\tau_2} + F_3 e^{-t/\tau_3} + \dots \quad (1)$$

and compare with equation

$$\frac{\sigma}{\epsilon} = \beta F(t) = E_0 + E_1 e^{-t/\tau_1} + E_2 e^{-t/\tau_2} + E_3 e^{-t/\tau_3} + \dots \quad (2)$$

we conclude that $E_0 = \beta F_0$, $E_1 = \beta F_1$, $E_2 = \beta F_2$, etc.

D.4

$$\beta = 3.24 \times 10^5 \text{ gf}^{-1} \text{ N m}^{-2}.$$

0.3pt

D.5

For a purely elastic process, $\sigma = \epsilon E_0$ and

$$F = \alpha \sigma = \alpha \epsilon E_0.$$

Thus, a graph of a constant function is expected.

D.5

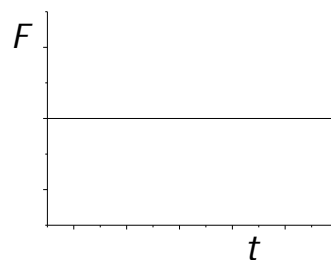

0.4pt

D.6

The data for $\frac{dF}{dt}$ inserted in table introduced in A.3, was computed numerically for equal time intervals. However, the graphical method is also exemplified. In the present graph, tangent lines to $F(t)$ are drawn at four different time instants (1200, 1500, 1800 and 2100 s). The slopes of those lines are a measure of $\frac{dF}{dt}$ at those instants.

D.6 See in the table used in A.3, the column with $\frac{dF}{dt}$.

0.5pt

This graph is present only if a graphical method is used.

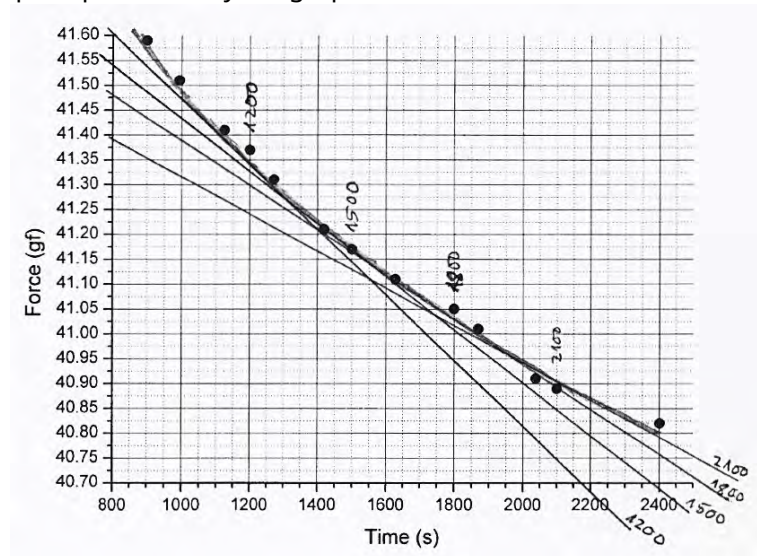

Confidential

D.7

For a single viscoelastic process,

$$F = \frac{1}{\beta} (E_0 + E_1 e^{-t/\tau_1}) = F_0 + F_1 e^{-t/\tau_1} .$$

Therefore,

D.7

$$\frac{dF}{dt} = -\frac{F_1}{\tau_1} e^{-t/\tau_1} , \quad \text{where} \quad F_1 = \frac{E_1}{\beta} .$$

0.3pt

D.8

The linearisation of the expression of dF/dt is accomplished using logarithms:

$$\ln \left(-\frac{dF}{dt} \right) = \ln \left(\frac{F_1}{\tau_1} \right) - \frac{1}{\tau_1} t .$$

The plot of $\ln(-dF/dt)$ is shown in the graph below for a case where the derivative was obtained numerically (left) and using a graphic method (right).

For the left graph, the best straight line is $\ln(-dF/dt) = m_1 t + b_1$ where $m_1 = (-6.47 \pm 0.62) \times 10^{-4}$ and $b_1 = (-6.52 \pm 0.11)$, using t in seconds and the force in gram-force units. If the derivative is computed numerically for unequal time intervals, the final parameters E_1 and τ_1 are similar.

The best straight line for the right graph yields $m_1 = (-6.00 \pm 0.15) \times 10^{-4}$ and $b_1 = (-6.63 \pm 0.02)$ using t in seconds and the force in gram-force units.

Thus, using the data from the left graph, $\tau_1 = \frac{1}{-m_1} = 1546$ s and

$$F_1 = \tau_1 e^{b_1} = 2.28 \text{ gf} \Rightarrow E_1 = \beta F_1 = 7.39 \times 10^5 \text{ N m}^{-2} .$$

For the right graph, the final parameters are $\tau_1 = 1667$ s and $E_1 = 7.13 \times 10^5 \text{ N m}^{-2}$.

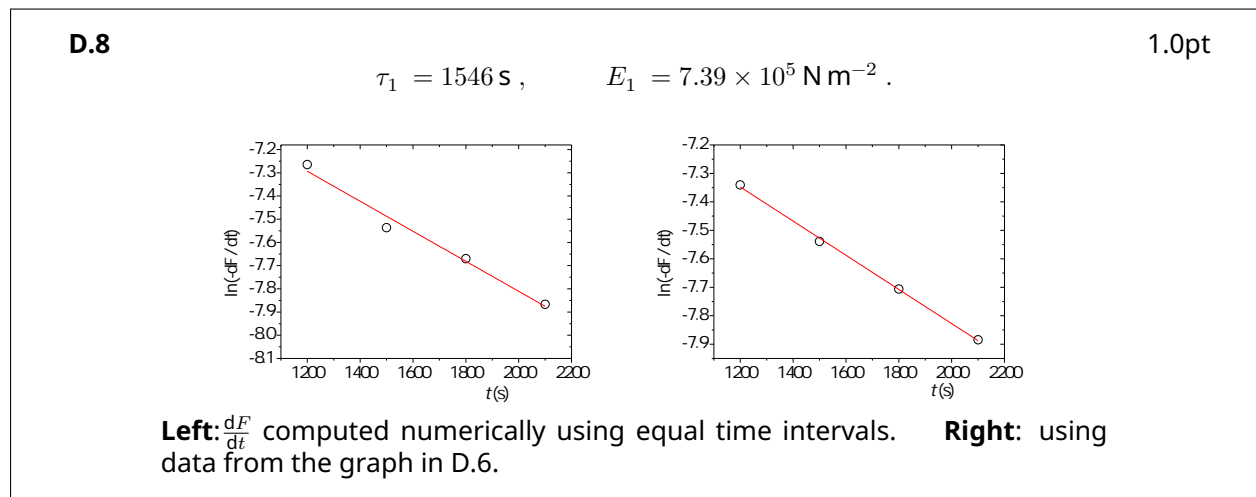

Confidential

D.9

For the 4 points on the left graph in D.8, we can write

$$F(t) = F_0 + F_1 e^{-t/\tau_1} \Rightarrow F_0 = F(t) - F_1 e^{-t/\tau_1}$$

Thus, averaging F_0 for the 4 points of the left graph in D.8:

$$F_0 = \left(\frac{40.32 + 40.31 + 40.34 + 40.30}{4} \right) = 40.32 \text{ gf}$$

Finally,

$$E_0 = \beta F_0 = 324293 \times 40.32 \text{ N m}^{-2} .$$

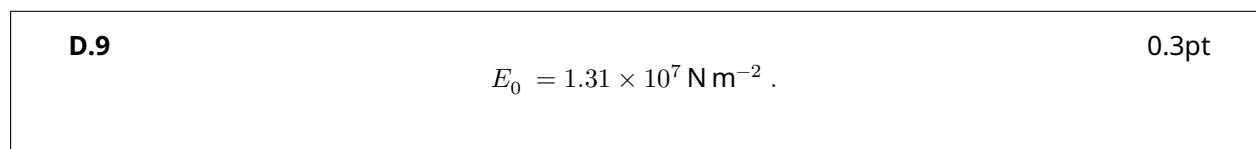

D.10

The function $y(t)$ is given by

$$y(t) = F(t) - F_0 - F_1 e^{-t/\tau_1},$$

and was added in the Table introduced in A.3 using $F_0 = 40.32$ gf, $F_1 = 2.28$ gf and $\tau_1 = 1546$ s.

D.10 See column $y(t)$ in the Table in A.3.

0.3pt

D.11

Since

$$y(t) = F(t) - F_0 - F_1 e^{-t/\tau_1},$$

then

$$y(t) = F_2 e^{-t/\tau_2} + F_3 e^{-t/\tau_3} + \dots, \quad \tau_2 > \tau_3 > \dots$$

At long times, when the contributions from the higher components are small enough, we expect a linear behaviour for $\ln y(t)$:

$$\ln y = \ln F_2 - \frac{1}{\tau_2} t.$$

In this case, the $y(t)$ data points become meaningless above 500 s. In the region 200-500 s the graph is linear and that region can be used to extract the parameters of the second component. The equation of the straight line is $\ln y_2 = b_2 + m_2 t$. From the graph below,

$$m_2 = -(5.65 \pm 0.19) \times 10^{-3} \Rightarrow \tau_2 = \frac{1}{-m_2} = 177 \text{ s}$$

$$b_2 = 0.33 \pm 0.07 \Rightarrow F_2 = e^{b_2} = 1.39 \Rightarrow E_2 = \beta F_2 = 4.5 \times 10^5 \text{ N m}^{-2}.$$

D.11

1.0pt

$$E_2 = 4.5 \times 10^5 \text{ N m}^{-2}, \quad \tau_2 = 177 \text{ s}.$$

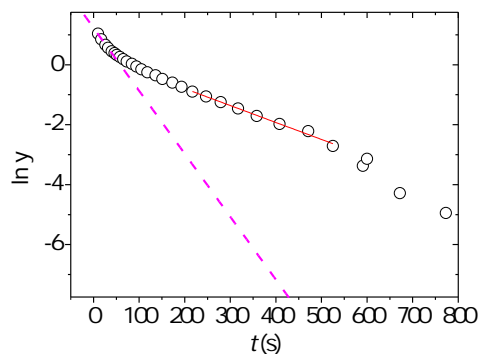

The best straight line in the range 200-500 s yield the parameters τ_2 and E_2 (Question D.11). The slope of the best straight line in the range [10, 30] s give an estimate of τ_3 (Questions D.12 and D.13).

D.12

Below around 30 s there is clear deviation from a linear behaviour indicating the presence of a third component. In our case, the first data point was acquired at $t = 10$ s.

D.12 (0.3 pt)

$$t_i = 10 \text{ s} \quad , \quad t_f = 30 \text{ s}$$

D.13

Drawing a line in the graph using the first data points (in the range defined in D.12), as shown in the graph in D.11, τ_3 can be estimated as:

$$m_3 = -0.02 \Rightarrow \tau_3 \approx m_3^{-1} ,$$

D.13

0.3pt

$$\tau_3 \approx 50 \text{ s} .$$

Part E. Measuring E in constant stress conditions (0.6 points)

E.1

From Question C.1 we have

$$\ell'_0 = (32.60 \pm 0.2) \text{ cm} .$$

The final length ℓ' should be measured. In our case,

$$\ell' = 42.2 + 2 \times 0.5 = 43.2 \text{ cm} \Rightarrow \ell' = (43.2 \pm 0.2) \text{ cm} .$$

Therefore, the strain is

$$\epsilon = \frac{\ell' - \ell'_0}{\ell'_0} = 0.325 .$$

Given that

$$E = \frac{\sigma}{\epsilon} = \frac{\frac{Mg}{\pi R^2}}{\epsilon} = \frac{80.2 \times 10^{-3} \times 9.8}{\pi \times (0.24 \times 10^{-3})^2 \times 0.325} = 1.337 \times 10^7 \text{ N m}^{-2} .$$

Note that the radius R of the stretched thread was not measured. We used the value measured in task B.4: $R \approx 0.24 \times 10^{-3} \text{ m}$.

The relative difference is

$$\frac{E - E_0}{E_0} = 0.021 .$$

E.1

$$E = 1.337 \times 10^7 \text{ N m}^{-2} , \quad \frac{E - E_0}{E_0} = 2.1\% .$$

0.6pt