

دوره آموزشی ۲- المانهای رگلاتور و مکانیزم های بارگیری

مزایا و معایب هر سیستم بارگیری

TESCOM™

REGULATOR BASIC ELEMENTS
LOADING MECHANISMS
ADVANTAGES & DISADVANTAGES

EDUCATINAL PROPOSAL

شرکت طاهاکیمیا تجهیز

<http://regulators.ir/>

info@tahakimia.com

Tel: +98-21-66431041, 66944330, 66921407



Basics of Pressure Regulation

Technical Information

DEBUL2008X012

What is a regulator?

A pressure reducing regulator is a device which reduces a high source pressure (e.g. an inlet pressure of 3000 psig / 207 bar) to a lower working pressure (e.g. an outlet pressure of 100 psig / 6.9 bar) that is suitable for a user's application. The regulator will attempt to maintain the outlet pressure within acceptable limits as other conditions vary. Source pressure and media (gas or liquid) flow are among these varying conditions. A regulator's accuracy and efficiency in performing its function is determined by the combination of the basic regulator elements designed into a specific regulator unit.

The basic elements of a regulator often will determine the regulator type and series selected for a specific application. In this manual, it will discuss the three basic elements common to all pressure reducing regulators whether manufactured by TESCOM or other manufacturers.

Pressure Reducing Regulator/Valve (PRV)

The function of a pressure reducing regulator is to precisely reduce a high upstream pressure of a gas or liquid (from a cylinder, compressor, pump, etc) to a lower, stable pressure for the user's application. Furthermore, the regulator will attempt to maintain and control the outlet pressure within limits as other conditions vary but the regulator will not control flow, only the delivery pressure. A regulator should not be used as a shut-off device as there is always a small amount of leakage across the seat. A shut-off valve must be used downstream of the regulator if isolation is required.

Backpressure Regulator/Valve (BPR)

The function of a backpressure regulator is to limit and precisely control the upstream pressure of a gas or liquid (from a tank, pump, etc) and is much more accurate than a relief valve. Most direct spring operated safety relief valves have a high reseating pressure which is inconsistent and unreliable. This is the primary difference between a safety relief valve and a backpressure regulator. A safety relief valve is designed to protect downstream personnel and equipment should over-pressurization take place. As such, when it's set pressure is overcome, it will blow wide open immediately and exhaust all of the

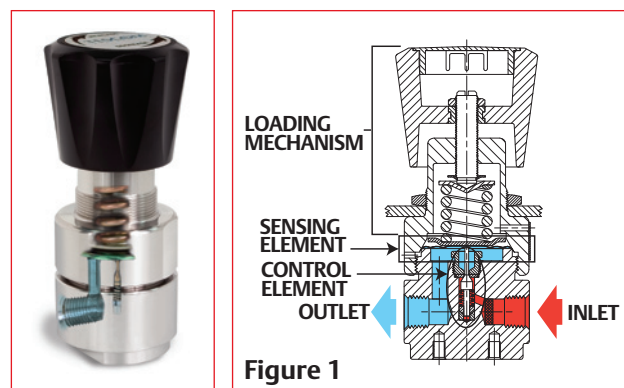

Figure 1

pressure. It needs to be able to handle the full flow of the system in order to rapidly exhaust to protect downstream apparatus. A backpressure regulator is not a safety device, it is designed for precision upstream pressure control. When the regulator set-point is overcome, it will "crack" open (not blow wide open) and try to exhaust just the excess pressure above the set-point. When it cracks open, it uses its sensing element (relief valves do not have sensing elements) to reseat very close to its original set pressure. Most TESCOM backpressure regulators have "crack-to-reseat" pressures less than $\pm 2\%$ of the set-point (relief valves are typically $\pm 10\%$).

Three Basic Elements

The Three Basic Elements are:

1. The **LOADING MECHANISM** provides the means by which the operator can set the force that determines the outlet (control) pressure of the regulator. P_2 is a term commonly used for outlet pressure.
2. The **SENSING ELEMENT** senses the changes in the outlet pressure (P_2) through a cavity located underneath it, allowing the regulator to react accordingly to these changes in P_2 .

The sensing element also provides a physical link between the loading element and the control element.

3. The **CONTROL ELEMENT** acts to reduce the inlet pressure, commonly called P_1 , to a lower working pressure and maintain it by increasing or decreasing the orifice area as the control element moves away or towards the seat.

*Elgiloy® is a registered trademark of Elgiloy Corp.
Teflon® and Viton® are registered trademarks of E.I. du Pont de Nemours and Company.
Hastelloy® is a registered trademark of Haynes International, Inc.
Gylon® is a registered trademark of Garlock, Inc.
Chemraz® is a registered trademark of Greentweed.*

I. Loading Mechanisms

The first basic element is the **LOADING** mechanism of a regulator. This mechanism determines what the regulator outlet pressure (P_2) will be.

The load element provides the force which is in turn transmitted through the **SENSING** element and to the **CONTROL** element, to provide the desired outlet pressure. It provides a preload force which establishes the demand level of the regulated or outlet pressure.

There are four types of loading:

- Spring Load
- Dome Load (also called gas or liquid loading)
- Air Load
- Combination of Spring and Dome Load

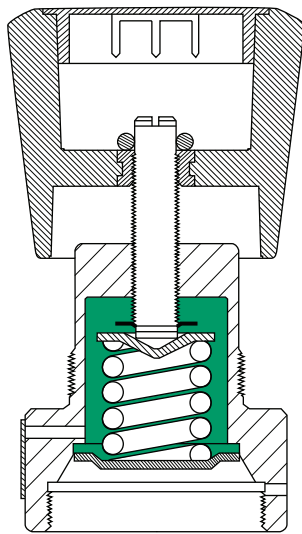

SPRING LOAD

Figure 2

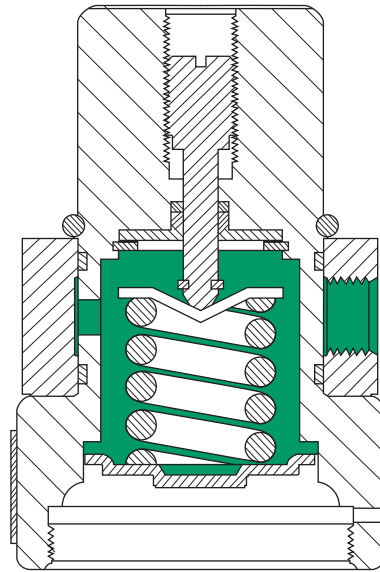

SPRING AND DOME LOAD

Figure 4

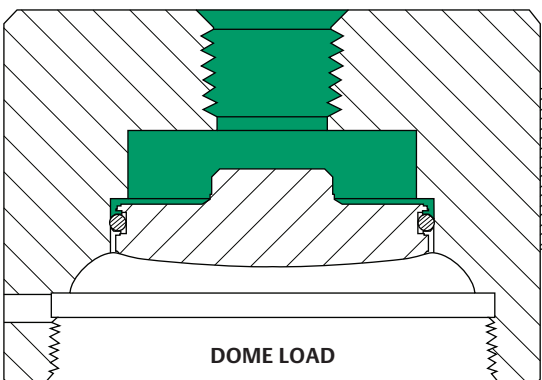

DOME LOAD

Figure 3

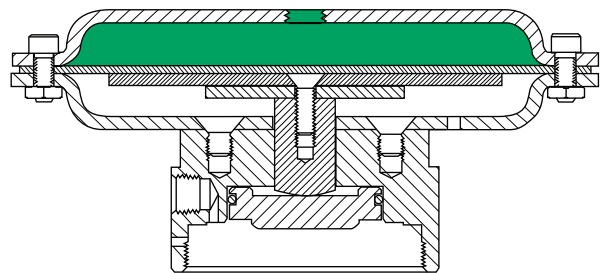

AIR LOAD

Figure 5

I. Loading Mechanisms

A. Spring Load

The spring (Figure 6) is the most common loading device in regulators because of its dependability and low cost.

The spring load is determined by the amount of compression placed on the spring by the operator. This is accomplished by turning the regulator knob or adjusting screw in a clockwise direction (Figure 7). The knob is turned, compressing the load spring, until the desired outlet or set pressure is reached on the regulator's outlet pressure gauge.

Caution must be used during adjustment to prevent thread stripping. This commonly occurs when an operator attempts to set an outlet pressure which exceeds the regulator's capacity or the available inlet pressure.

The mechanical advantage of a standard adjusting screw or handknob provides easy adjustment for outlet pressures up to 500 psig / 34.5 bar. For high pressures, up to 15,000 psig / 1034 bar, TESCOM uses a non-rising stem handknob with bearings that enables manual adjustment of pressures with only 30-40 in-lbs / 3.4-4.5 N•m of torque.

Advantages

- Simple design
- Relatively small size
- Springs of various rate can be adjusted to provide different outlet pressures
- There is a variety of spring sources which makes the prices competitive and economical

Disadvantages

- Spring forces vary with compression and thus the load is not uniform
- Susceptible to the effects of shock, vibration and temperature

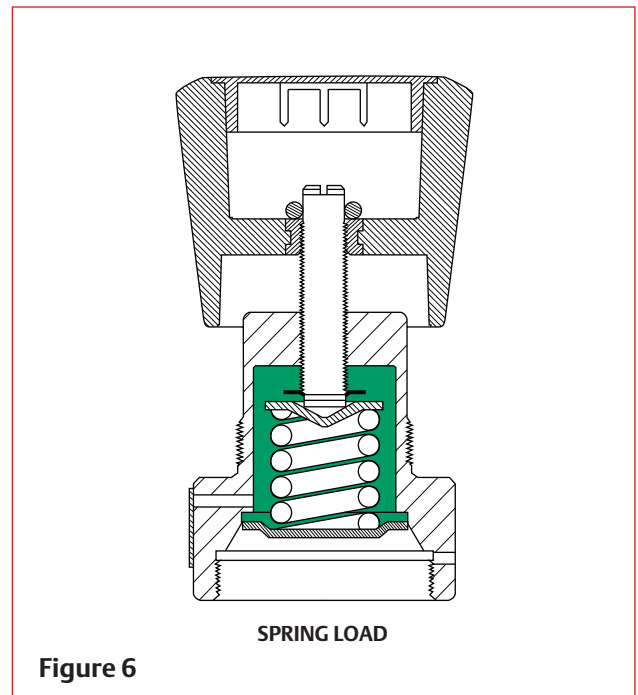

Figure 6

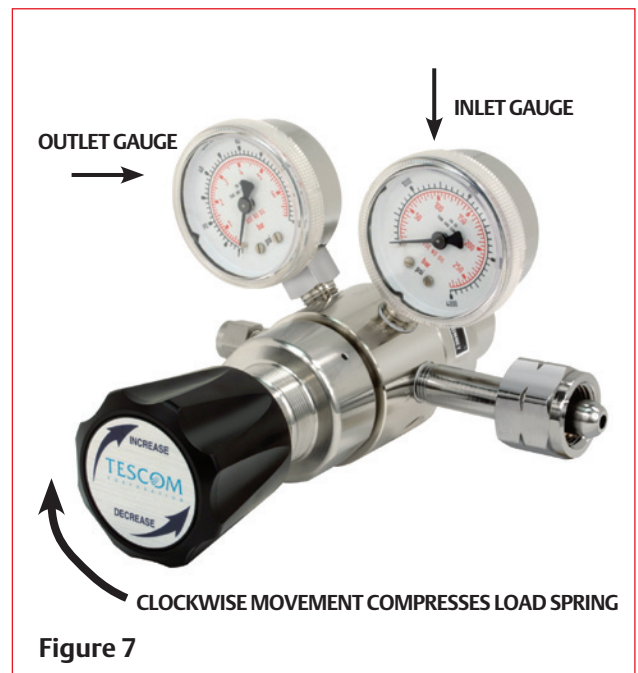

Figure 7

I. Loading Mechanisms

B. Dome Load

The second loading method is called dome load (Figure 8). Instead of a spring, pressure in the dome area is used to provide loading force to the regulator. This is accomplished by sealing the dome area to prevent leaks and then pressurizing it with gas or liquid coming from a pilot regulator.

The pressure in the dome determines the regulator's outlet pressure. The dome pressure is essentially equal to the regulator outlet pressure.

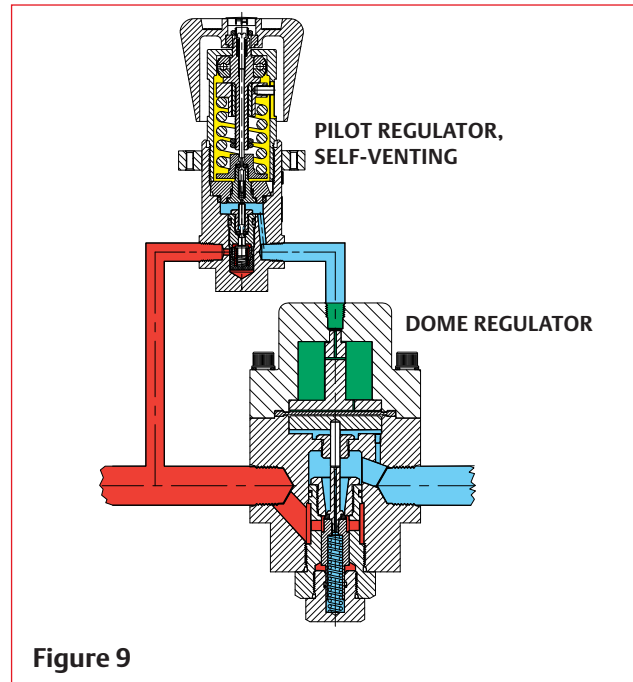
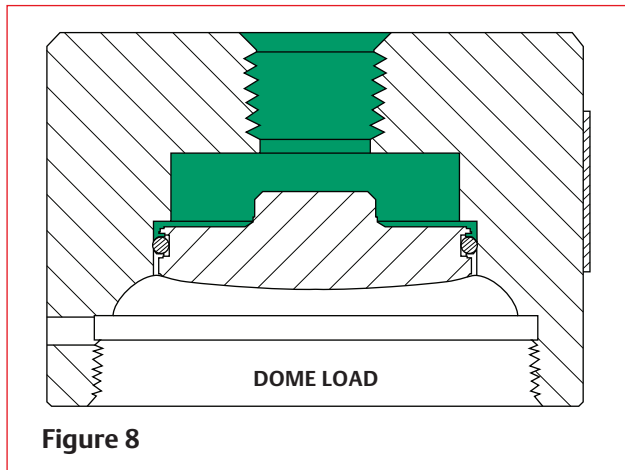

Figure 9

Almost all TESCOM regulator series are available with dome load.

Advantages

- Enables remote pressure control which allows the operator to adjust pressure at a safe distance, away from hazardous gases or conditions
- Offers convenience by providing a means of adjusting pressure when the dome regulator is located in an area difficult to reach
- Maintains outlet pressure more accurately under flowing conditions than a spring loaded regulator, minimizing droop
- Faster response to pressure changes

Disadvantage

- Requires two regulators: the dome regulator and the pilot regulator. This means increased cost and greater space requirement for installation

In the example in Figure 9, a 26-1200 Series dome loaded regulator is connected to a 26-1000 Series venting regulator. The 26-1000 regulator acts as a pilot regulator and provides the loading pressure to the dome of the 26-1200 regulator. To set the pressure in the dome, the pressure coming from the pilot regulator is adjusted until the outlet pressure gauge of the dome regulator reads the desired set pressure.

If the dome is loaded to 1000 psig / 69.0 bar, then the outlet pressure will be close to 1000 psig / 69.0 bar. The slight difference is primarily due to the control element (valve) spring force which counteracts the dome load pressure force.

When the regulator strokes downward in response to increased flow, the pilot regulator will add more gas to make up the pressure lost due to the increase in the dome area and keep the dome pressure constant. A pilot regulator with venting capability should be used to load dome loaded regulators. This venting capability is necessary to allow an operator to adjust the dome pressure in both increasing and decreasing directions.

I. Loading Mechanisms

C. Air Load

A third loading method is Air Actuated or Air Loaded. This is similar to dome load, but has a ratio greater than 1:1 between the loading force (pilot pressure) and the control pressure. This is the primary difference between a dome loaded and air loaded regulator. Another difference is inert gas can only be used to pilot an air actuated regulator. Dome loaded regulators can be piloted with either gas or liquid. Air actuated loading is available on many TESCOM regulator series and with our wide range of pressure capability up to 30,000 psig / 2069 bar we offer ratios from 2.5:1 to 375:1. The ratios are approximate, so in order to set the regulator at the desired setpoint you need to monitor a pressure indicator from the control pressure side of the regulator the same way you do with a dome loaded regulator. The maximum control pressure of the air actuated regulator is typically achievable with ~80 psig / ~5.5 bar pilot pressure. The mechanical advantage of air actuated regulators allows use of low pressure inert gas (facility air) and low pressure plumbing/pressure regulation for the pilot pressure source. It also allows use of TESCOM's ER3000 Electropneumatic Pressure Controller to provide the pilot pressure control as well as closed loop electronic control. Like the dome loaded regulator, the pilot pressure regulator/controller should be a venting type to allow pressure adjustment in both increasing and decreasing directions.

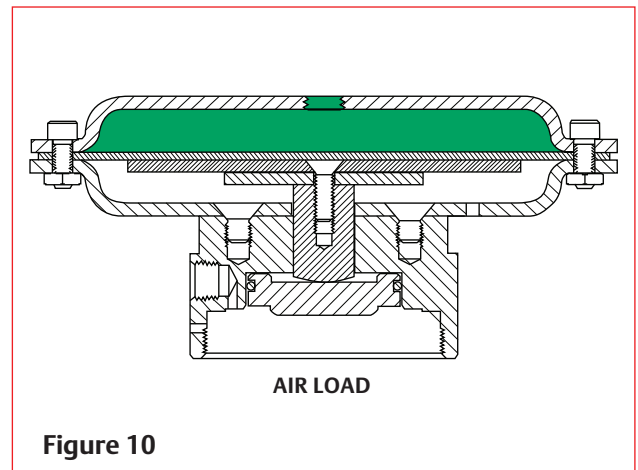

Advantages

- Provides a ratio between actuator pressure and media pressure (e.g. 1:75)
- Enables remote pressure control in combination with pilot regulators
- Low pressure drop under dynamic conditions (minimized droop)
- Allows use of low pressure inert gas (facility air) and low pressure plumbing/pressure regulation for the pilot pressure source
- Can be combined with the ER3000 Electropneumatic Controller

Disadvantage

- Requires two regulators: the air loaded regulator and the pilot regulator. This means increased cost and greater space requirement for installation

I. Loading Mechanisms

D. Combination of Spring and Dome Load

This hybrid regulator uses a combination of spring and dome loading (Figure 11) and is identified by several names:

- Bias Regulator
- Tracking Regulator
- Algebraic Regulator
- Differential Pressure Regulator

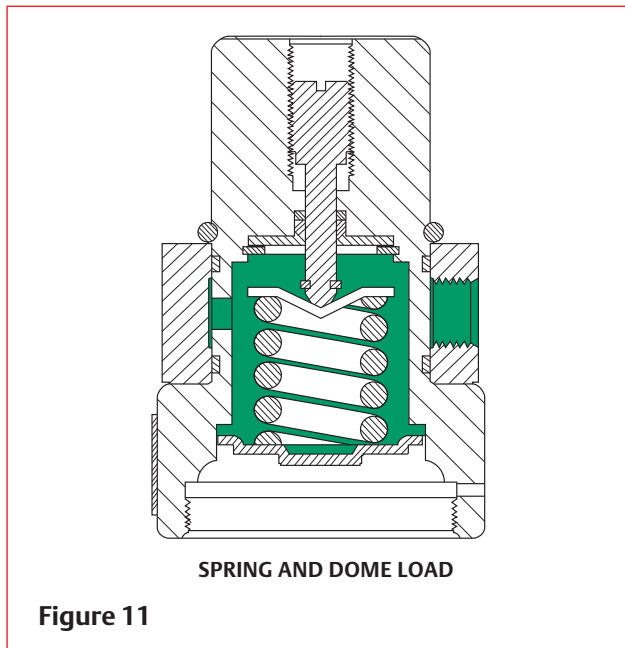

Figure 11

It is called a “bias” regulator because the spring provides a “bias” or added force.

The term “tracking” is used because the regulator can follow the pressure of one system as the pressure goes up or down. The regulator supplies pressure equal to the bias setting plus the reference pressure and sends the total pressure of the two signals to a second system.

It is sometimes called an “algebraic” regulator because it can add or subtract pressure equal to its bias spring setting. The pressure is added when the bias spring is located above the sensing element, diaphragm or piston, and subtracted when the bias spring is located below the sensing element.

This is how the combination dome and spring regulator works:

First, the bias spring is manually adjusted to provide a specific bias pressure, for instance 50 psig / 3.4 bar (Figure 12). The bias pressure will remain constant and maintain that difference above the reference pressure.

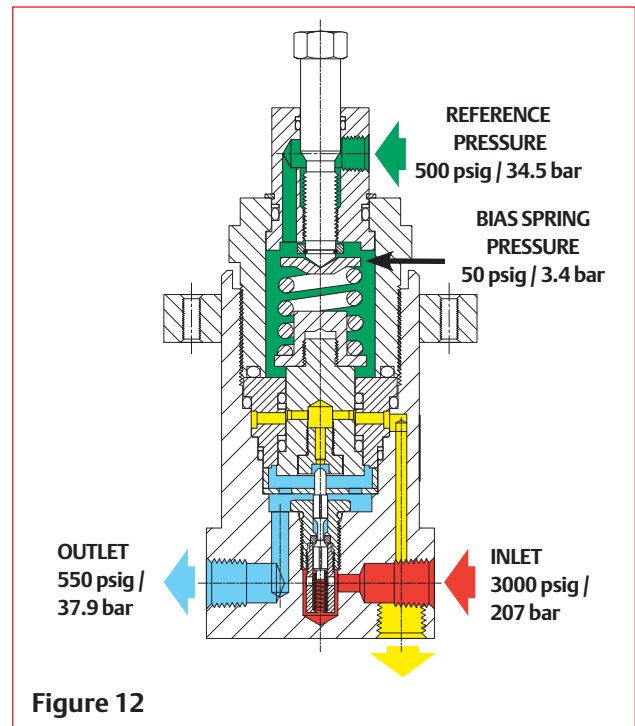

Figure 12

Then the dome is loaded with pressure from a “reference source”, another system, at a pressure of 500 psig / 34.5 bar. The dome is now loaded with a total of 550 psig / 37.9 bar, the sum of the bias pressure (50 psig / 3.4 bar) and pressure from the reference source (500 psig / 34.5 bar). The regulator will now deliver an outlet pressure of 550 psig / 37.9 bar.

If for any reason the reference should change either up or down and provided there is flow or the regulator has a venting feature, the outlet pressure will also change. An example: the reference pressure drops by 100 psig / 6.9 bar, from 500 psig / 34.5 bar down to 400 psig / 27.6 bar, the bias pressure set on the spring remains at 50 psig / 3.4 bar. Consequently the outlet pressure of the combination spring and dome regulator is now 450 psig / 31.0 bar.

Regulators with combination spring and dome load are used in a variety of applications and are especially useful in commercial diving, oil exploration, laboratory and autoclave applications.

Advantage

- Provides gas pressure accurately for tracking applications

Disadvantage

- More expensive than a spring or a dome loaded regulator