

# An Atlas of Structures, Mechanisms, and Robots

Dr. Bob Williams, [williar4@ohio.edu](mailto:williar4@ohio.edu)

Mechanical Engineering, Ohio University

© 2015 Dr. Bob Productions

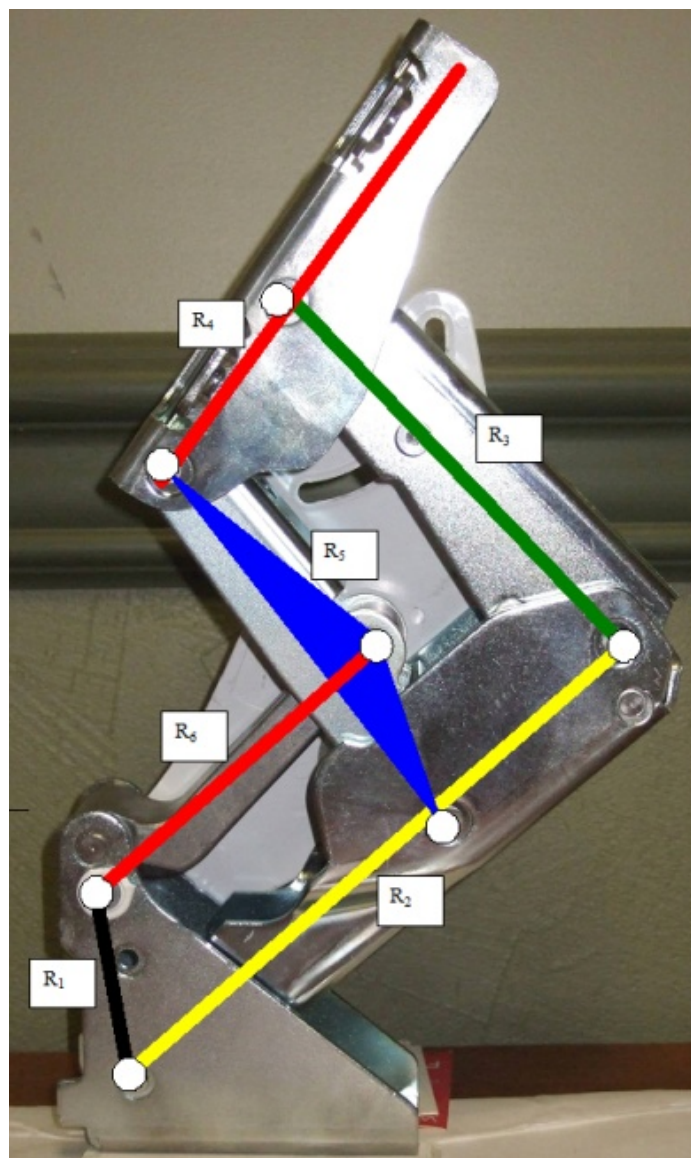

Hettich Hinge Watt I 6-bar Mechanism

# Table of Contents

<b>ZERO-DOF (OR LESS) STRUCTURES .....</b>	<b>3</b>
<b>ONE-DOF MECHANISMS .....</b>	<b>3</b>
<b>MULTI-DOF ROBOTS .....</b>	<b>16</b>
<b>REAL-WORLD MECHANISMS / KINEMATIC DIAGRAMS .....</b>	<b>18</b>
<b>MATLAB SIMULATION/ANIMATION GALLERY .....</b>	<b>19</b>

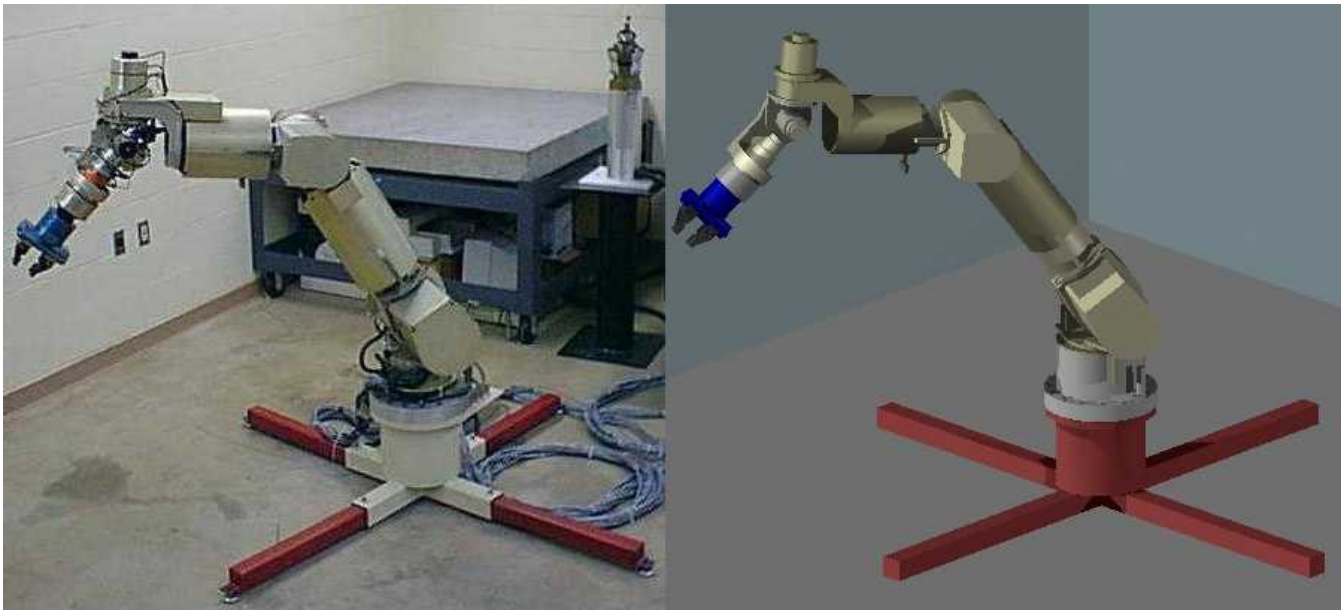

**NASA 8-dof ARMII Robot**

## Zero-dof (or less) Structures

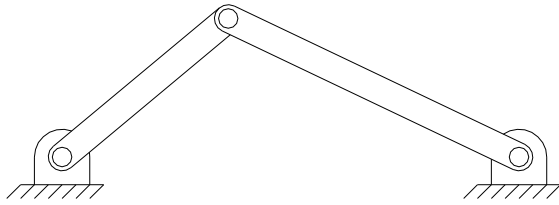

**Statically Determinate Structure**

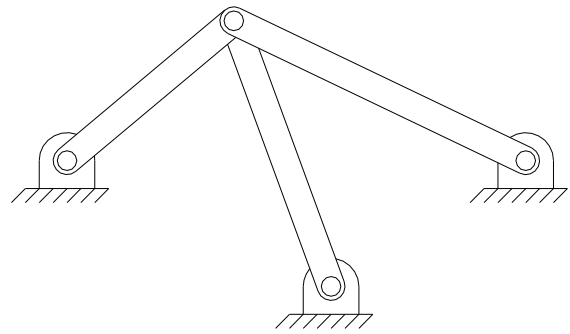

**Statically Indeterminate Structure**

## One-dof Mechanisms

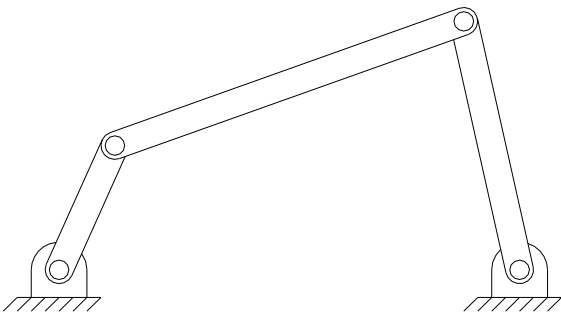

**4-Bar Mechanism**

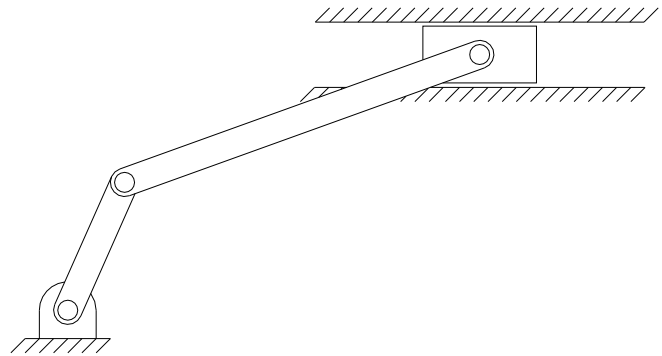

**Offset Slider-Crank Mechanism**

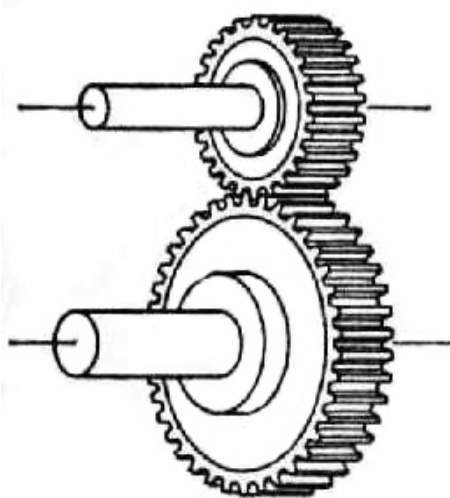

**Spur Gear Mechanism**

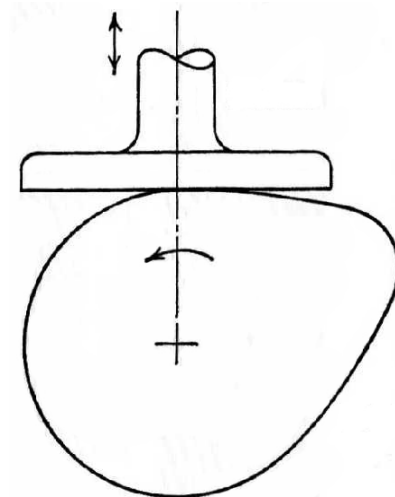

**Cam-and-Follower Mechanism**

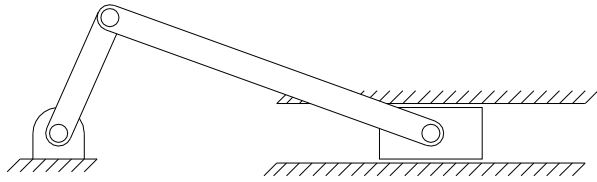

**Slider-Crank Mechanism Inversion 1**

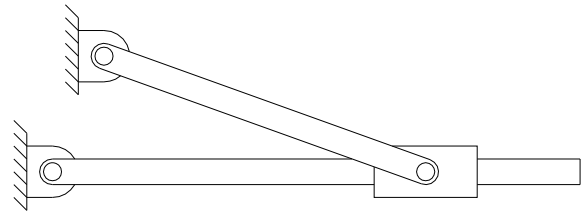

**Slider-Crank Mechanism Inversion 2**

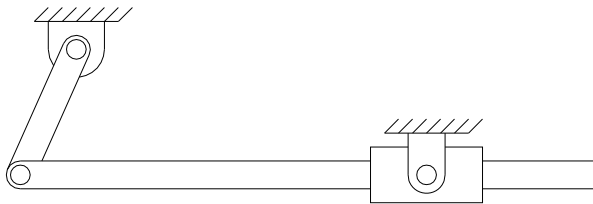

**Slider-Crank Mechanism Inversion 3**

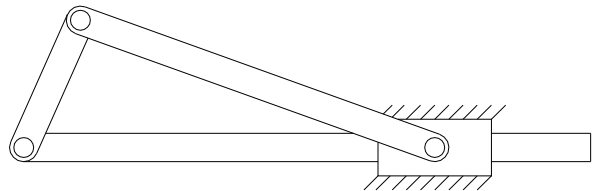

**Slider-Crank Mechanism Inversion 4**

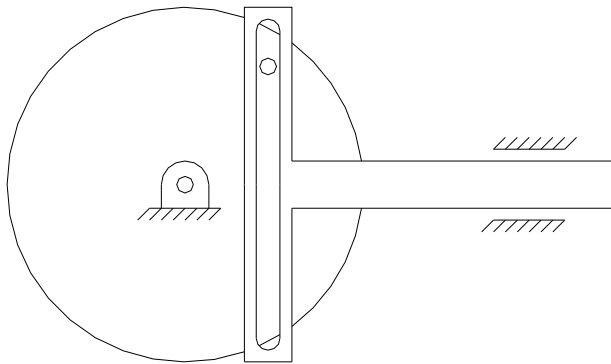

**Scotch-Yoke Mechanism**

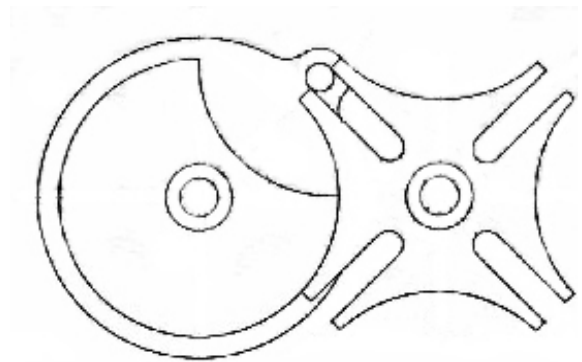

**Geneva Wheel Mechanism**

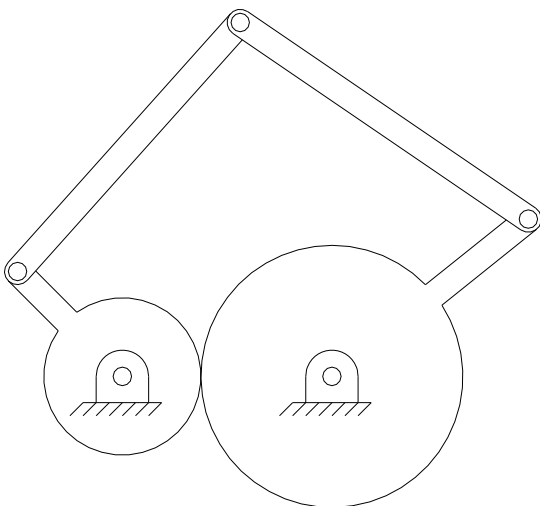

**Geared 5-Bar Mechanism**

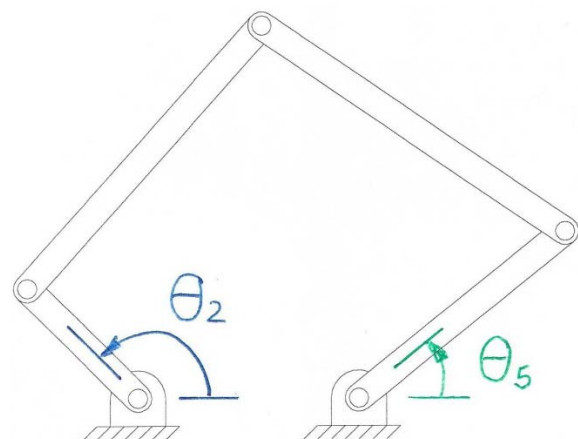

**2-dof 5-Bar Parallel Robot**

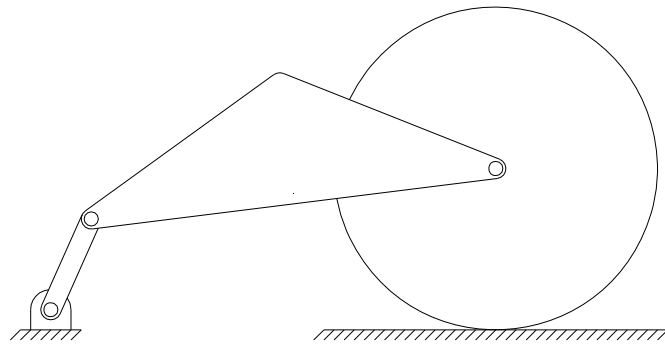

**4-Bar Rolling Mechanism**

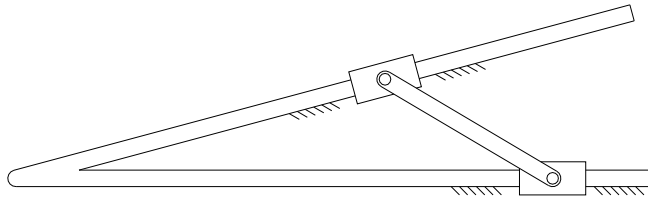

**Dual-Slider Mechanism**

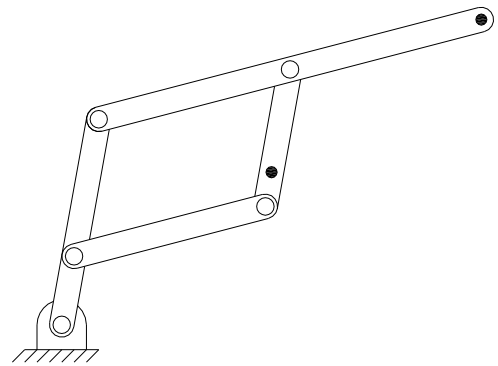

**Pantograph Robot**

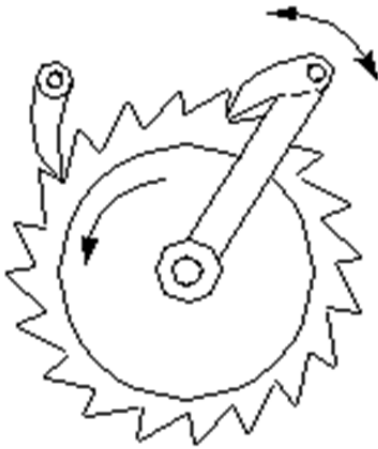

**Ratchet Mechanism**

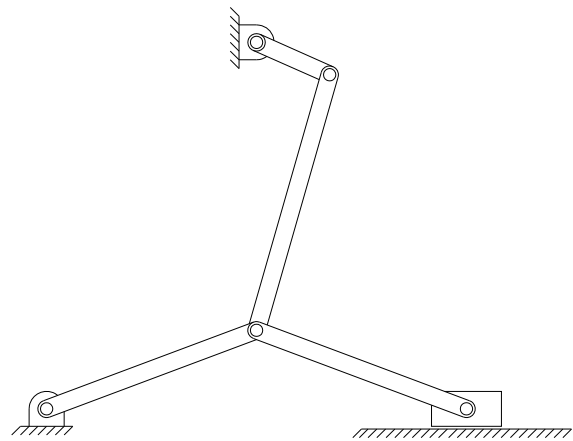

**Toggle Mechanism**

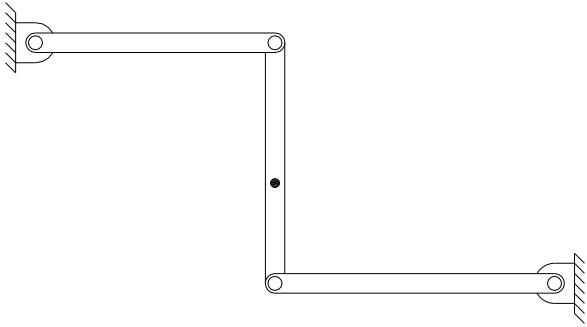

**Watt Straight-Line Mechanism  
(approximate)**

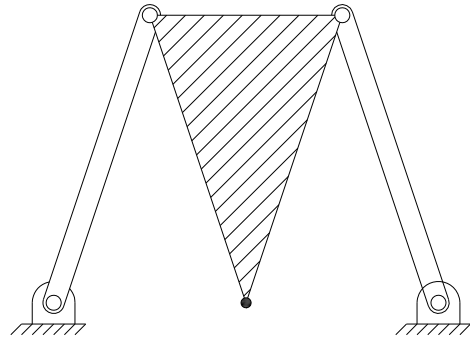

**Roberts Straight-Line Mechanism  
(approximate)**

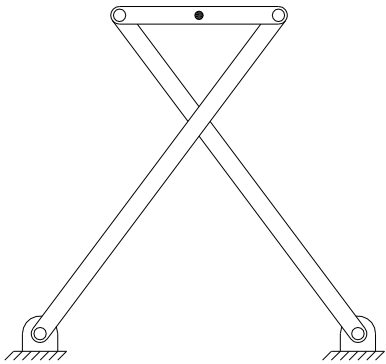

**Chebyshev Straight-Line Mechanism  
(approximate)**

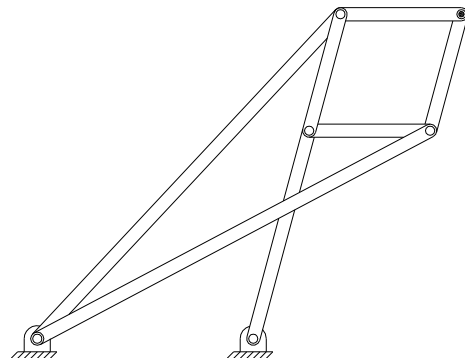

**Peaucellier Straight-Line Mechanism  
(exact)**

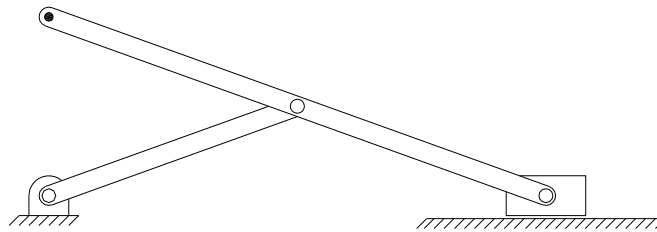

**Scott-Russell Straight-Line Mechanism  
(exact)**

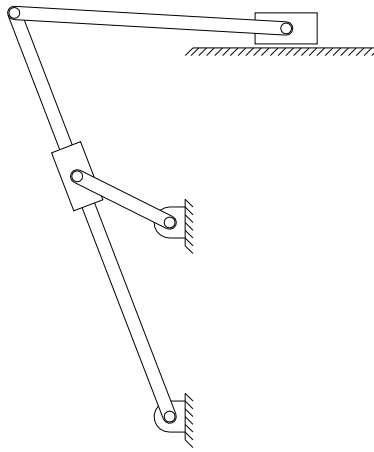

**Crank-Shaper Quick-Return Mechanism**

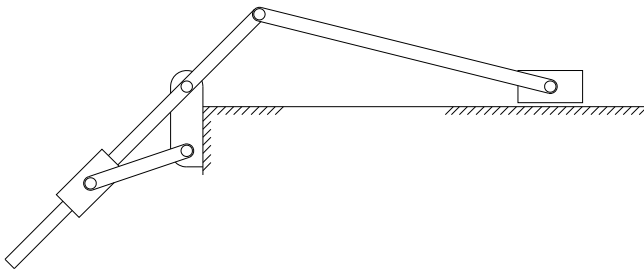

**Whitworth Quick-Return Mechanism**

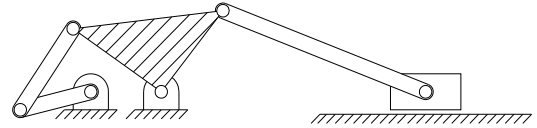

**Drag-Link Quick-Return Mechanism**

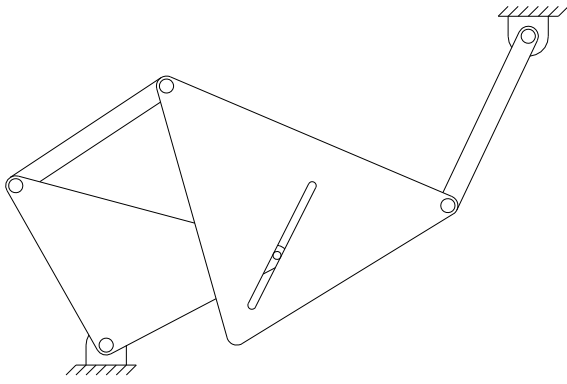

**5-bar Slotted Mechanism**

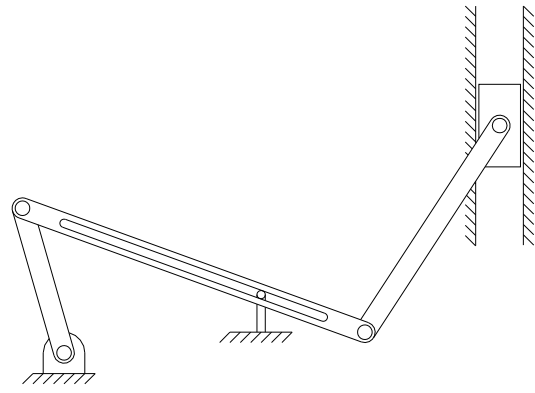

**5-bar Slotted Slider Mechanism**

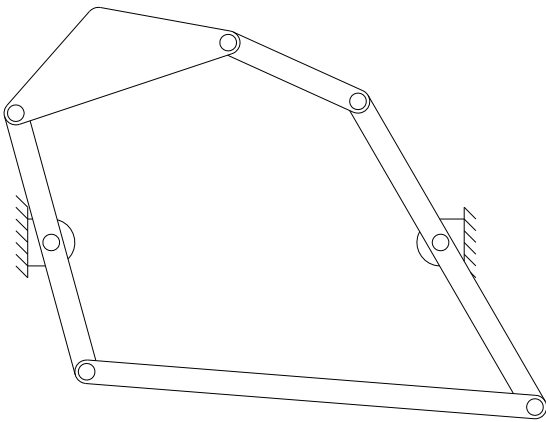

**6-bar Mechanism**

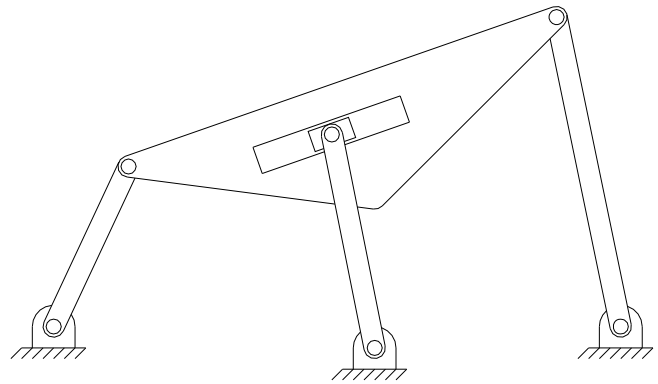

**6-bar Single-Slider Mechanism**

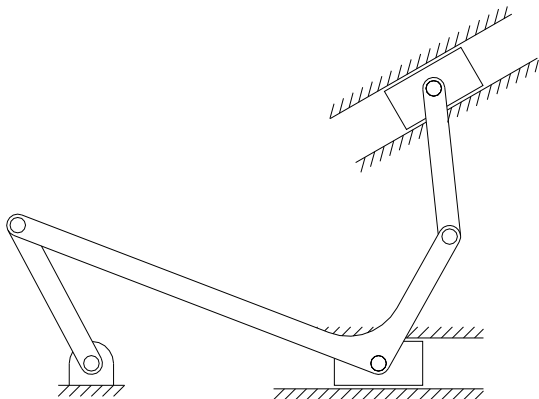

**6-bar Crank Dual-Slider Mechanism**

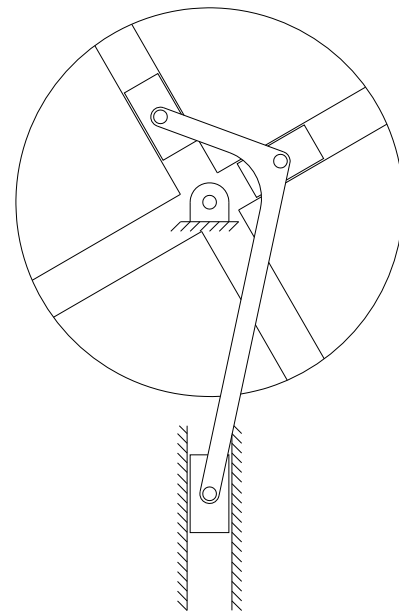

**6-bar Crank Triple-Slider Mechanism**



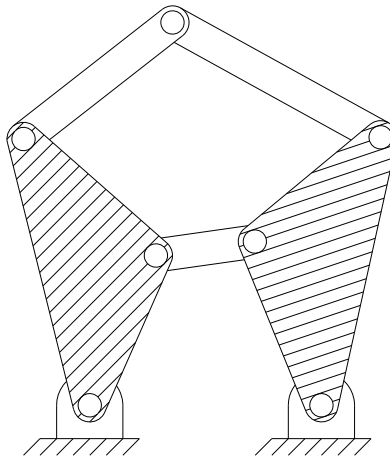

**Stephenson I 6-Bar Mechanism**

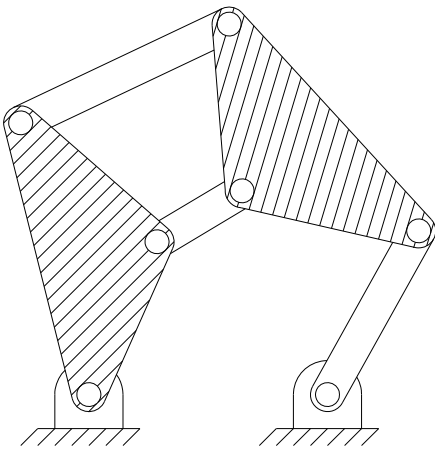

**Stephenson II 6-Bar Mechanism**

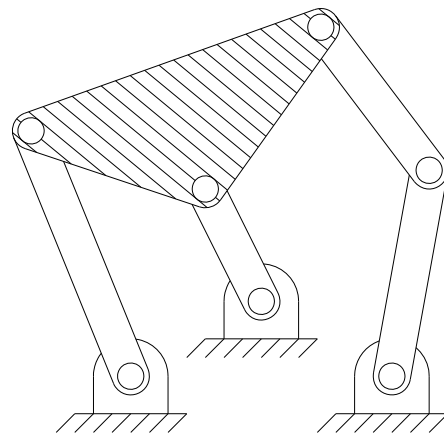

**Stephenson III 6-Bar Mechanism**

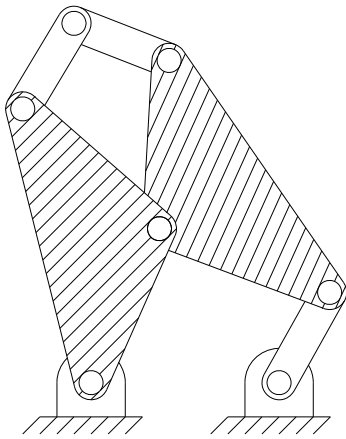

**Watt I 6-Bar Mechanism**

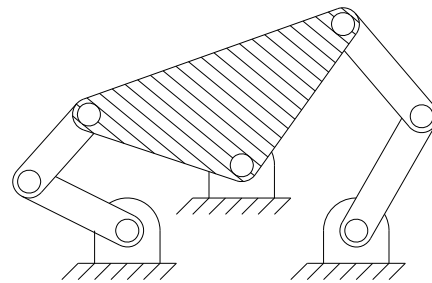

**Watt II 6-Bar Mechanism**

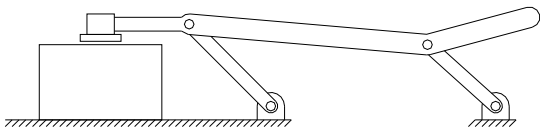

**4-Bar Clamp Mechanism**

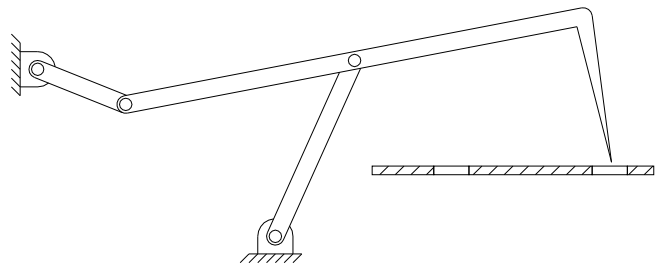

**4-Bar Film Advance Mechanism**

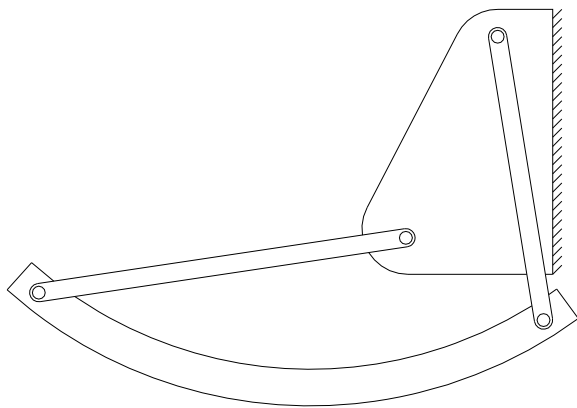

**4-Bar Aircraft Carry-on Bin Mechanism**

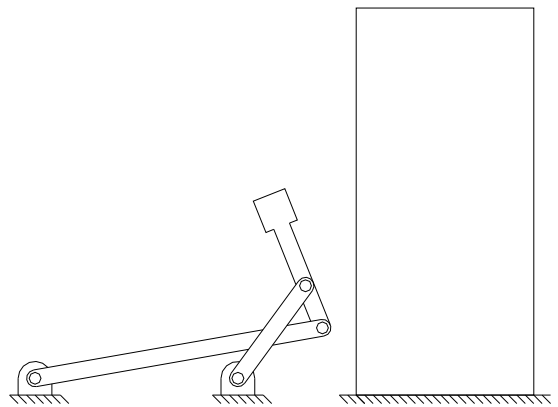

**4-Bar Bass Drum Pedal Mechanism**

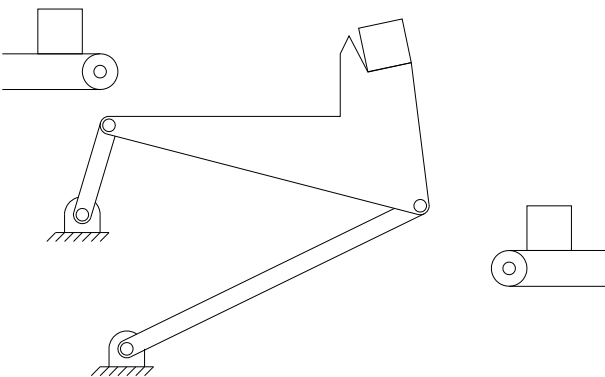

**4-Bar Conveyor Transfer Mechanism**

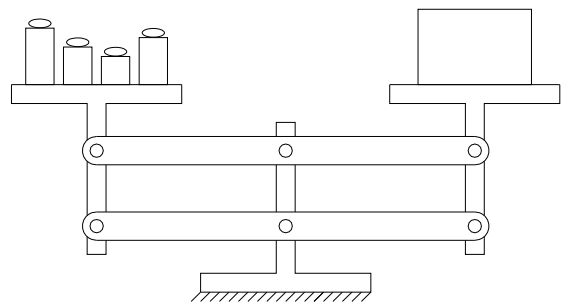

**Dual 4-bar Balance Scale Mechanism**

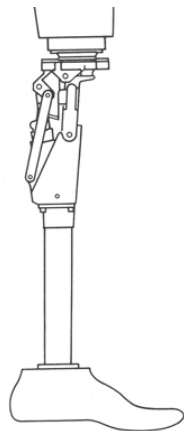

**4-Bar Knee Prosthesis Mechanism**

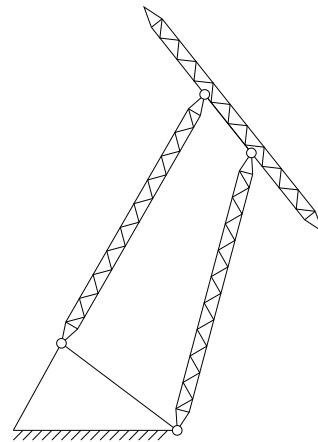

**4-Bar Crane Mechanism**

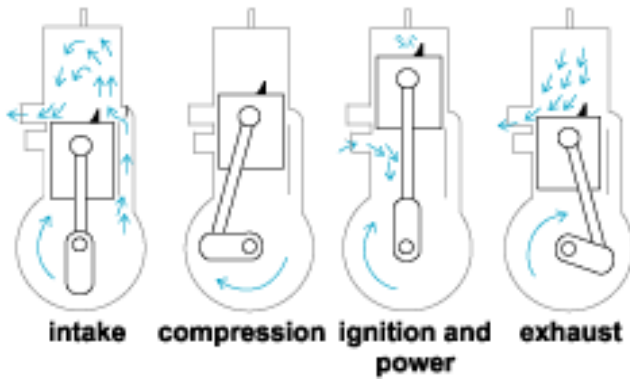

**2-Stroke Internal Combustion Engine Mechanism S-C Inversion 1**

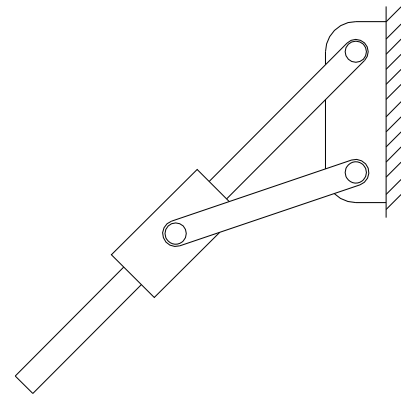

**Whitworth Mechanism S-C Inversion 2**

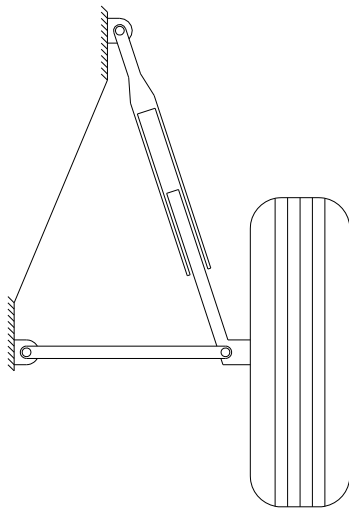

**MacPherson Strut Mechanism S-C Inversion 3**

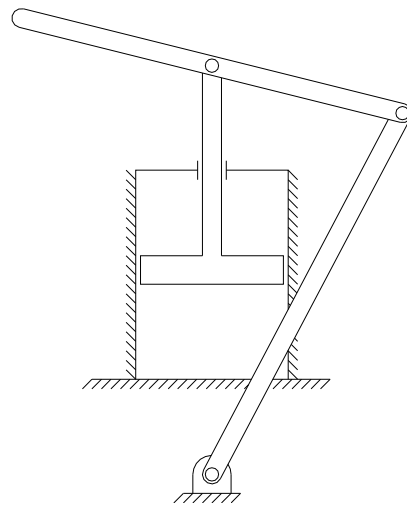

**Pump Mechanism S-C Inversion 4**

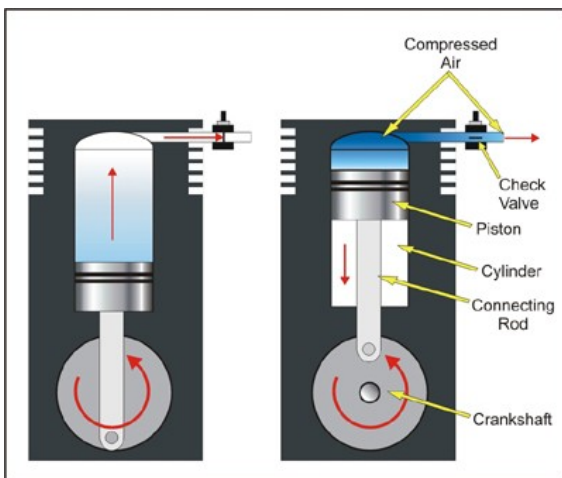

**Air Compressor Mechanism S-C Inversion 1**

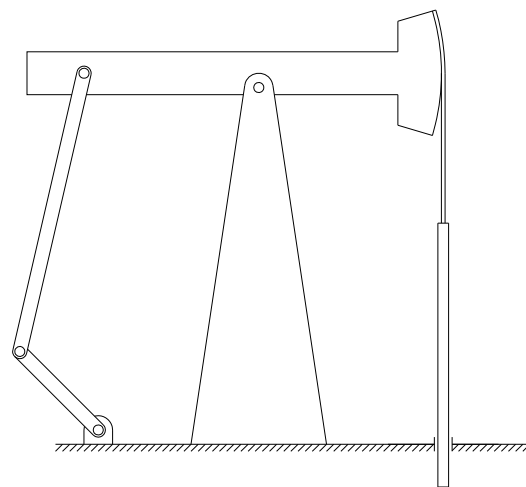

**5-bar Oil Well Pump Mechanism**

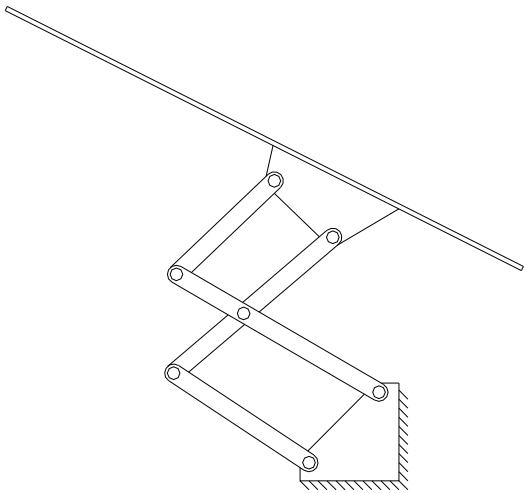

**6-bar Car Hood Mechanism**

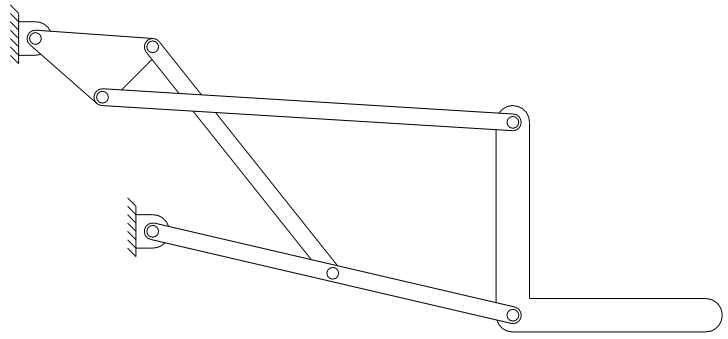

**6-bar Lift Mechanism**

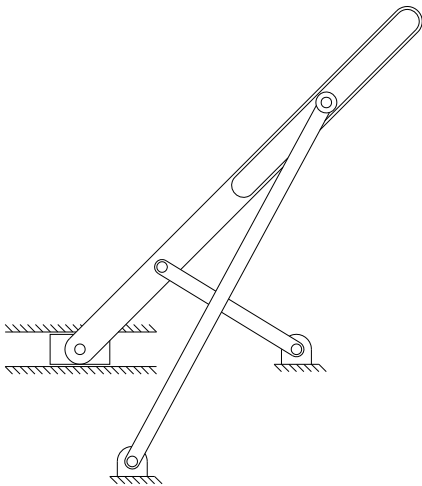

**6-bar Window Mechanism**

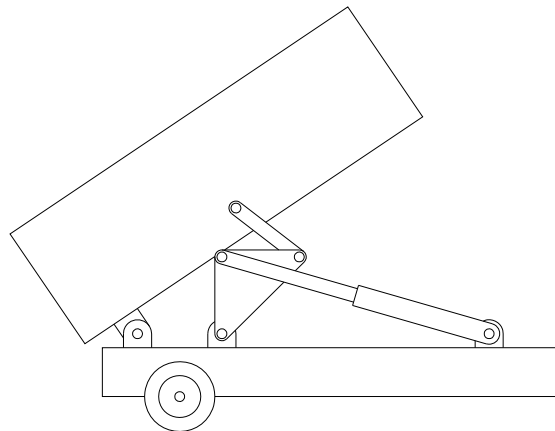

**6-bar Dump Truck Mechanism**

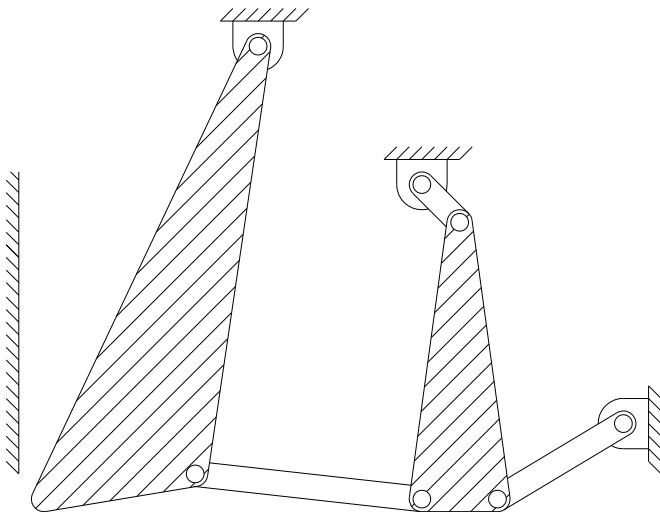

**6-bar Rock Crusher Mechanism**

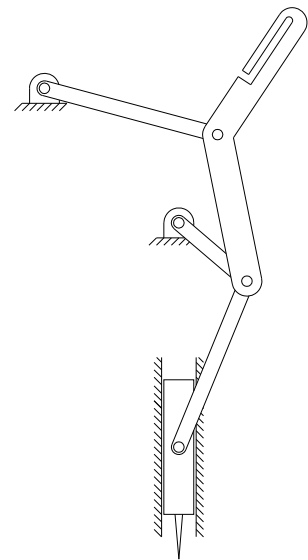

**6-bar Sewing Machine Mechanism**

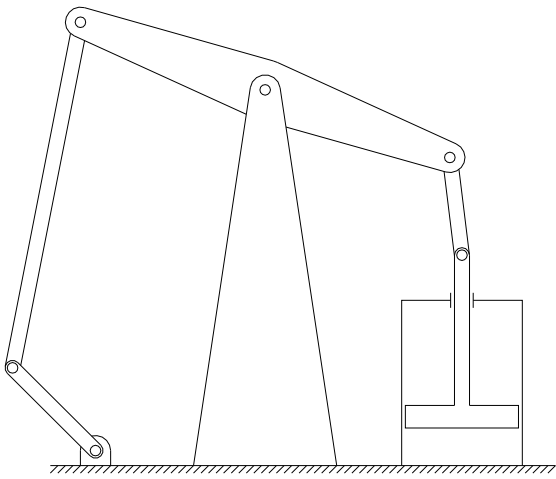

**6-bar Watt Steam Engine Mechanism**

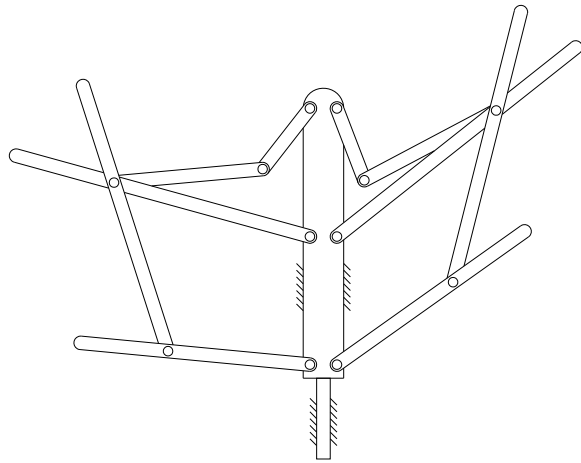

**Dual 6-bar Mechanism Collapsible Music Stand**

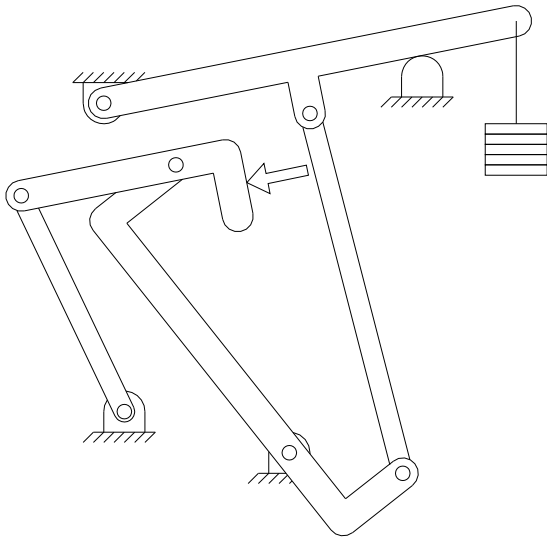

**6-bar Leg Press Mechanism**

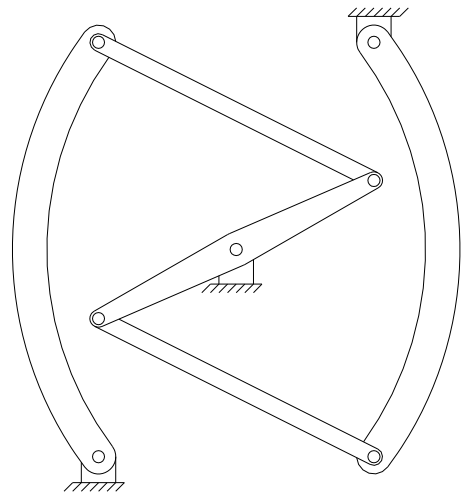

**6-bar Drum Brake Mechanism**

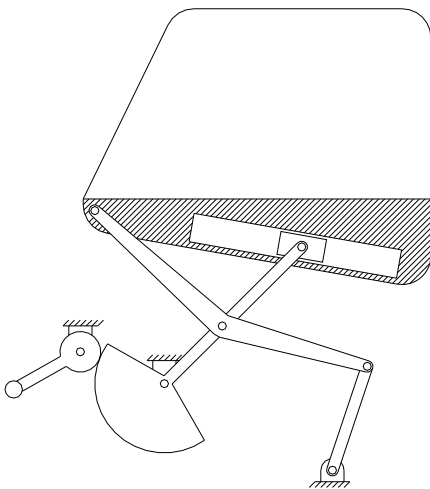

**7-bar Car Window Mechanism**

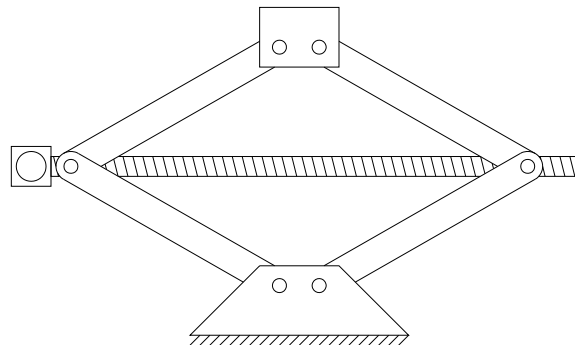

**7-bar Car Jack Mechanism**

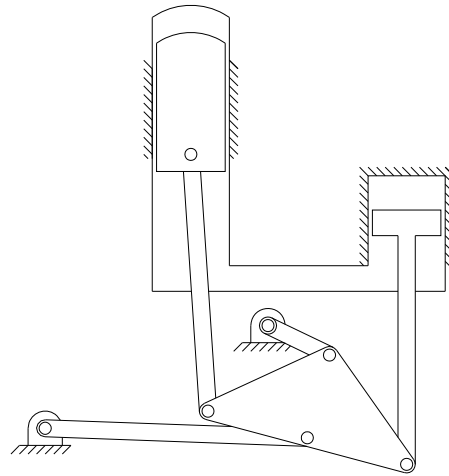

**7-bar Ross Stirling Engine Mechanism**

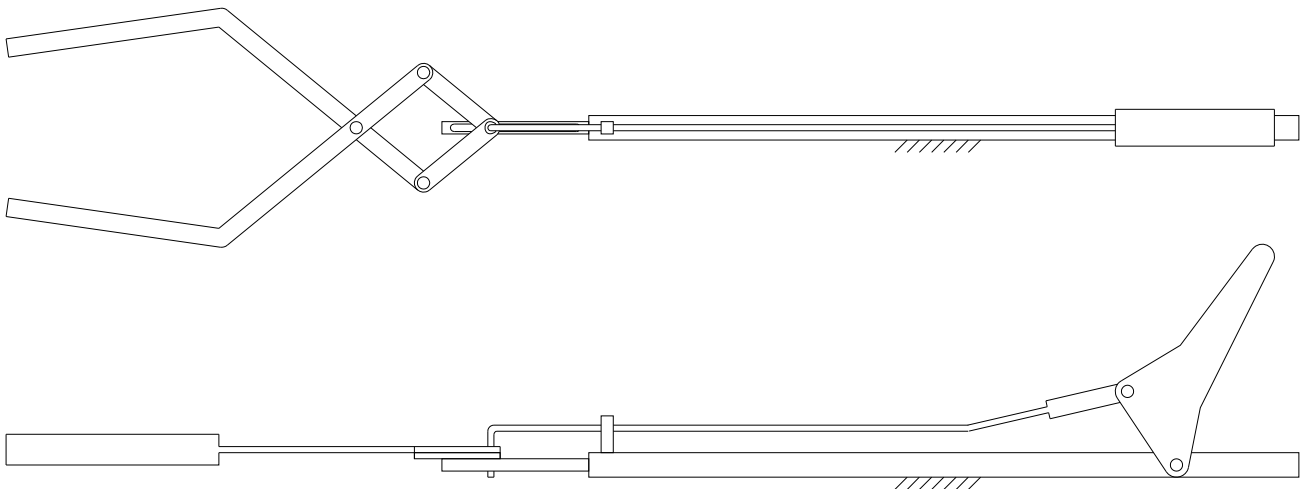

**7-bar Grabber/Extender Compound Mechanism**

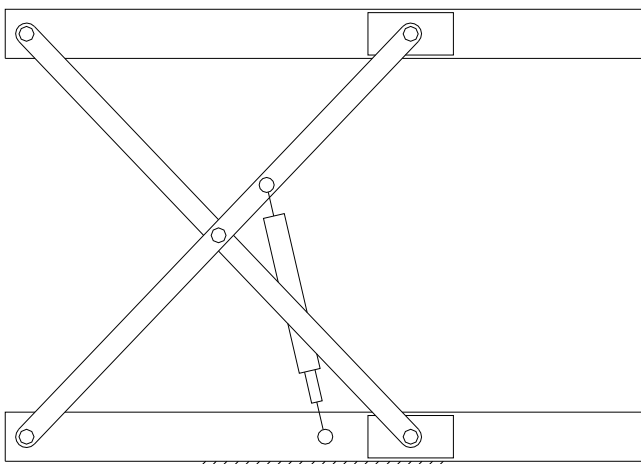

**8-bar Scissor-Lift Mechanism**

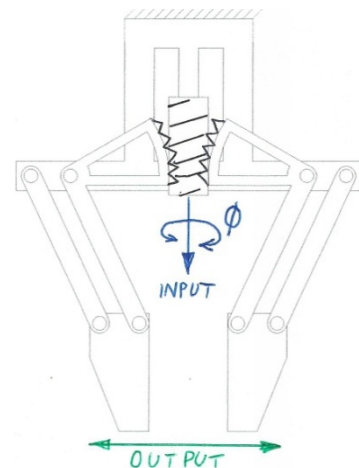

**8-bar Robot Gripper Mechanism**

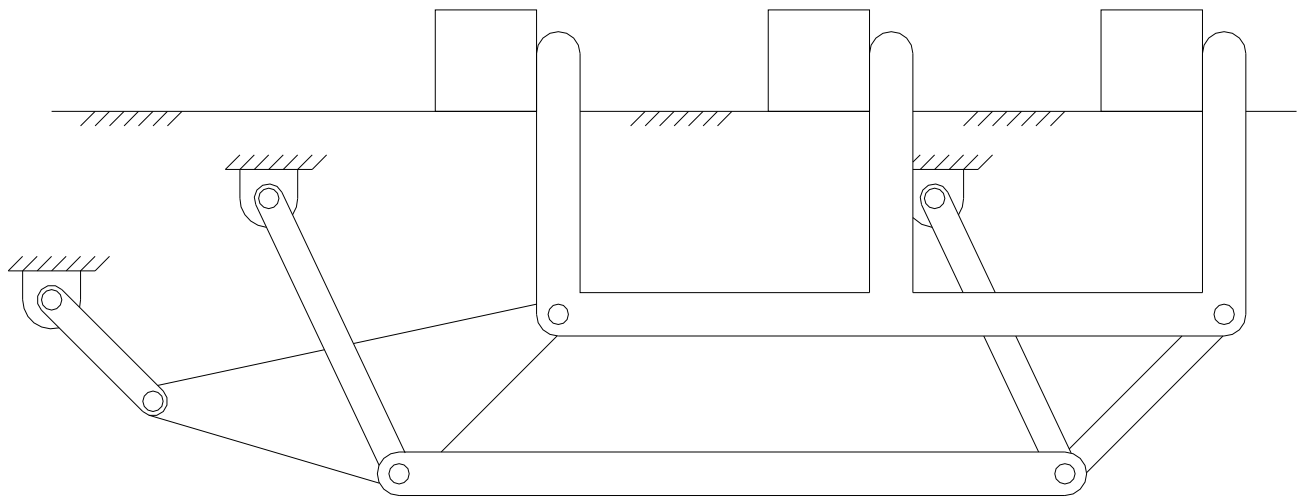

**8-Bar Straight-Line Transfer Mechanism**

## Multi-dof Robots

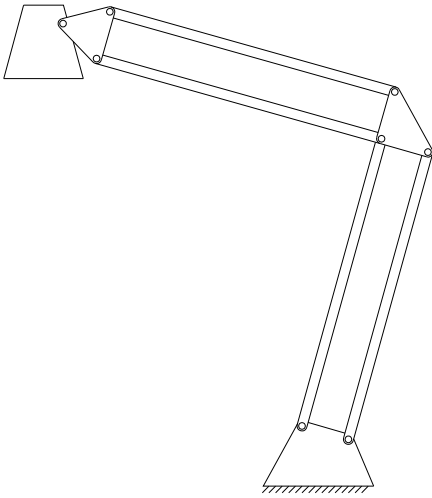

**3-dof 8-bar Desk Lamp Robot**

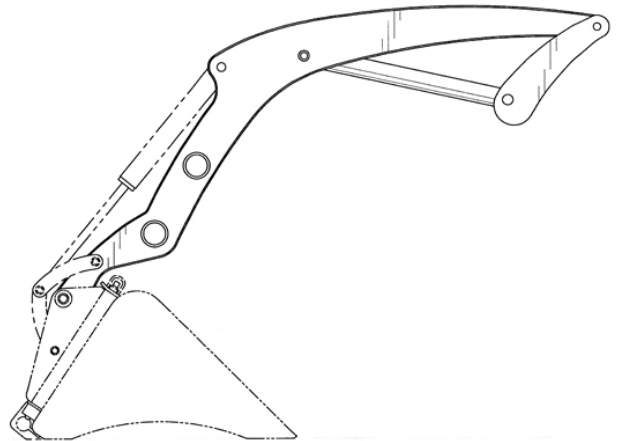

**2-dof 9-bar Front-End Loader Robot**

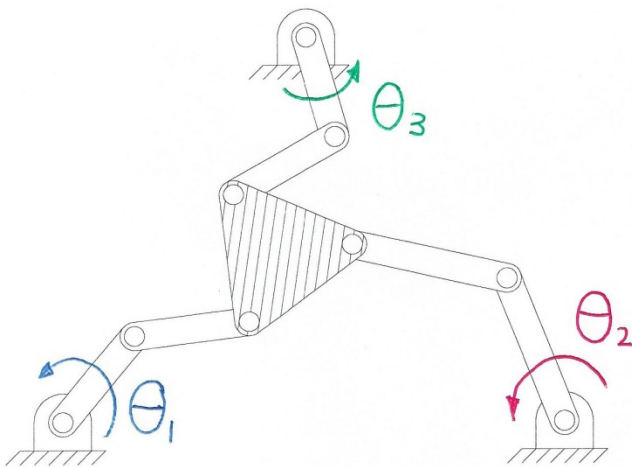

**3-dof 3-RRR Parallel Robot**

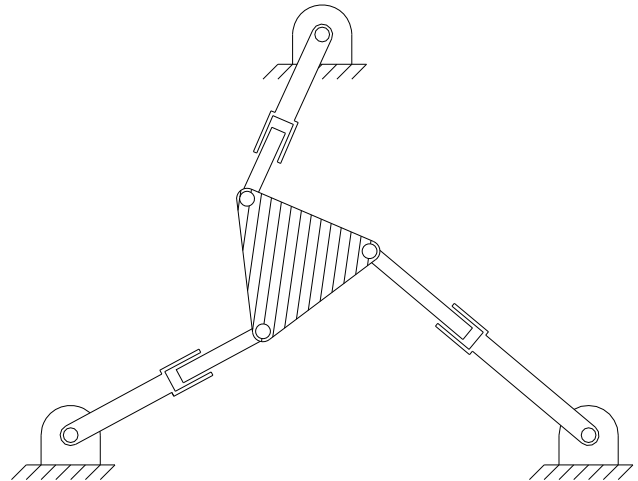

**3-dof 3-RPR Parallel Robot**



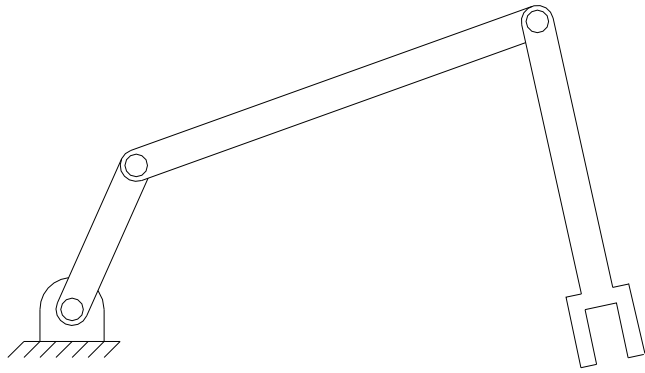

**Planar 3-dof Robot**



**Adept 4-dof SCARA Robot**

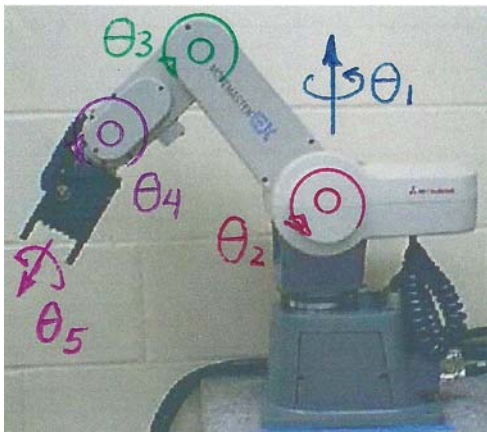

**Mitsubishi 5-dof Robot**

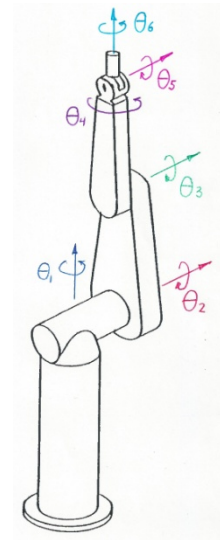

**PUMA 6-dof Robot**

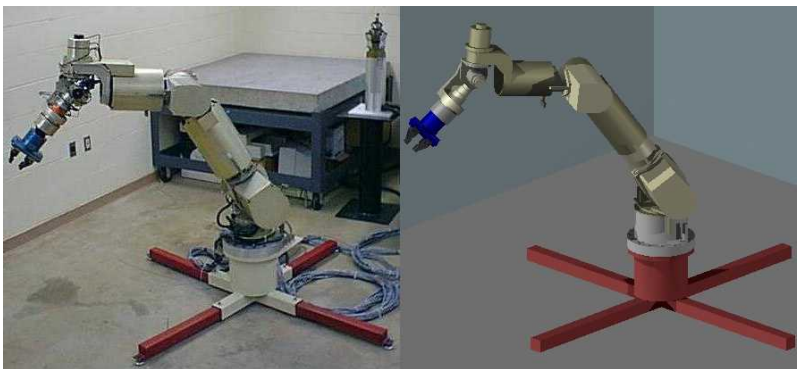

**NASA 8-dof ARMII Robot**

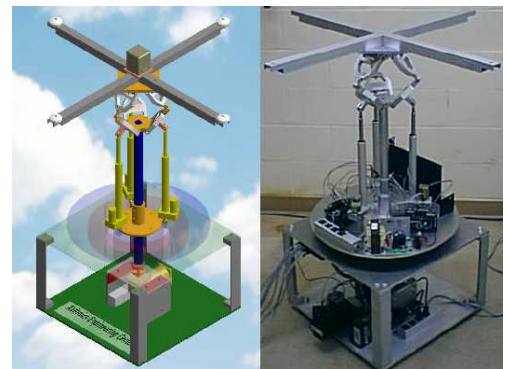

**3-dof Carpal Wrist Robot**

# Real-World Mechanisms / Kinematic Diagrams

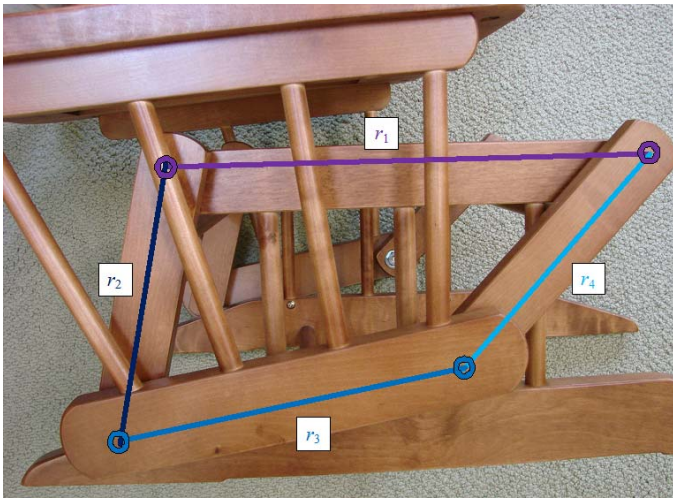

4-bar Glider-Rocker Mechanism



Bicycle/Human Leg 4-bar Mechanism (lock ankle)

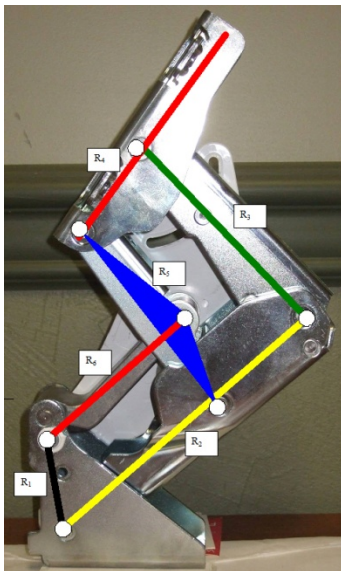

Hettich Hinge Watt I 6-bar Mechanism



Mountain Bike Rear Suspension Mechanism

## MATLAB Simulation/Animation Gallery

All of the following MATLAB graphics/animations were created by Dr. Bob at Ohio University. These are presented according to the Ohio University course they support.

### ME 3011 Kinematics & Dynamics of Machines and Introduction to Vibrations

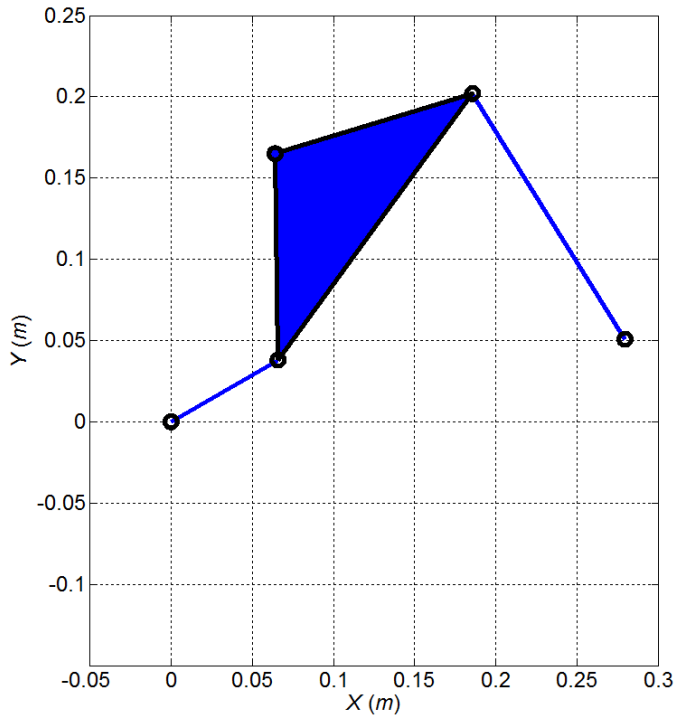

Open Branch

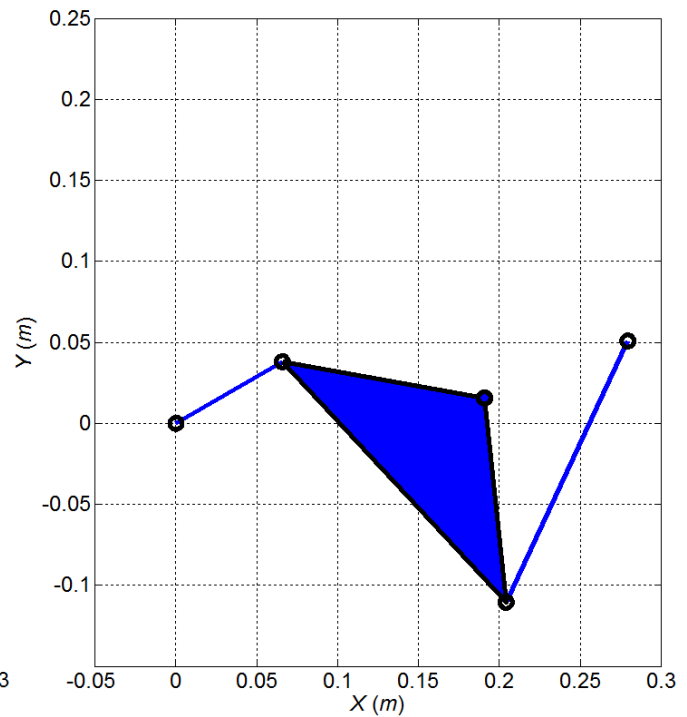

Crossed Branch

Four-Bar Mechanism

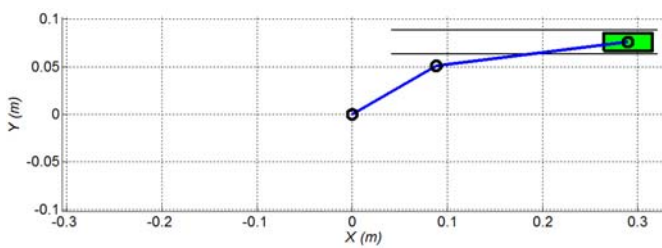

Right Branch

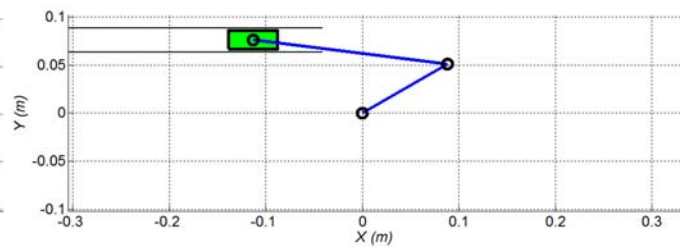

Left Branch

Slider-Crank Mechanism

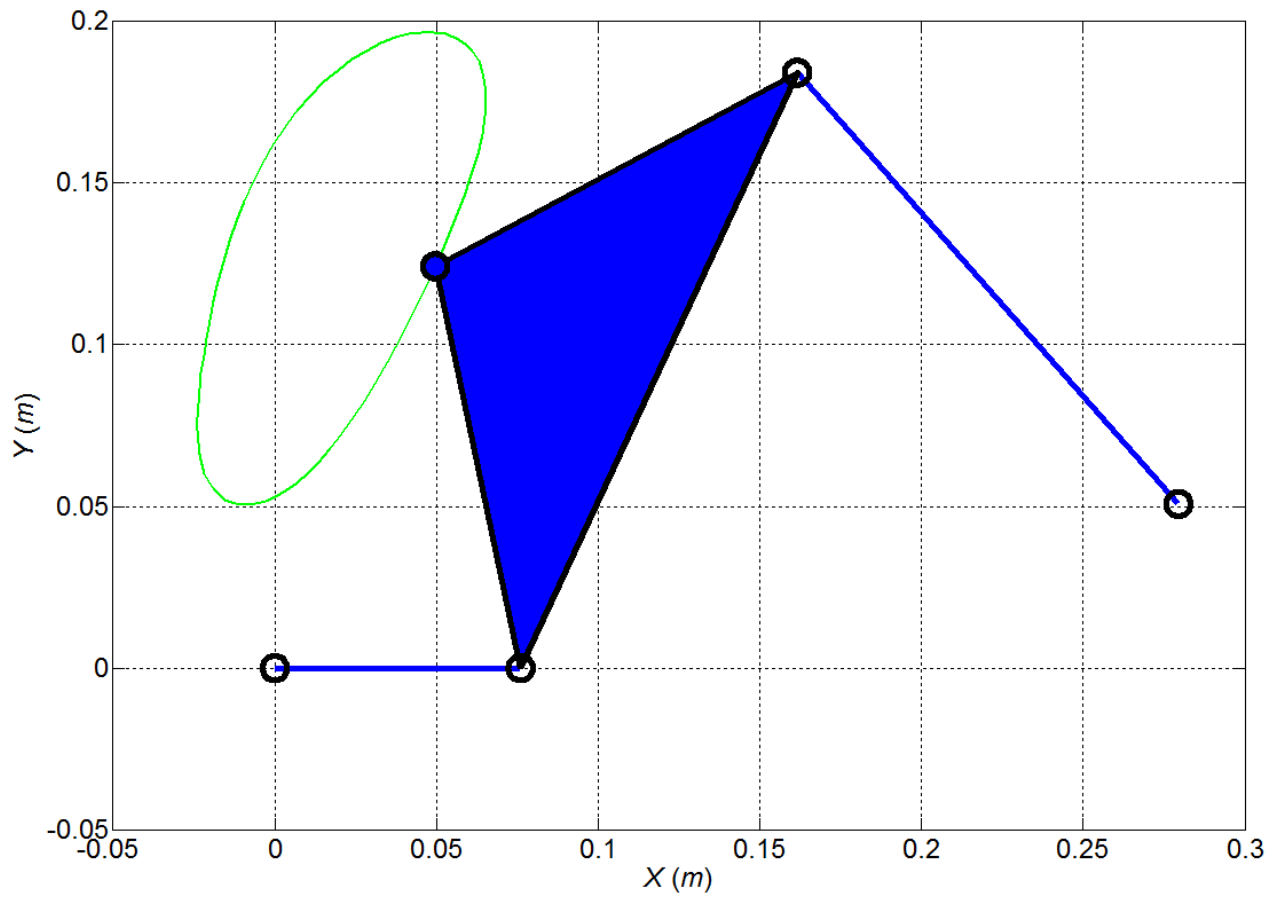

**Four-Bar Mechanism Coupler Curve**

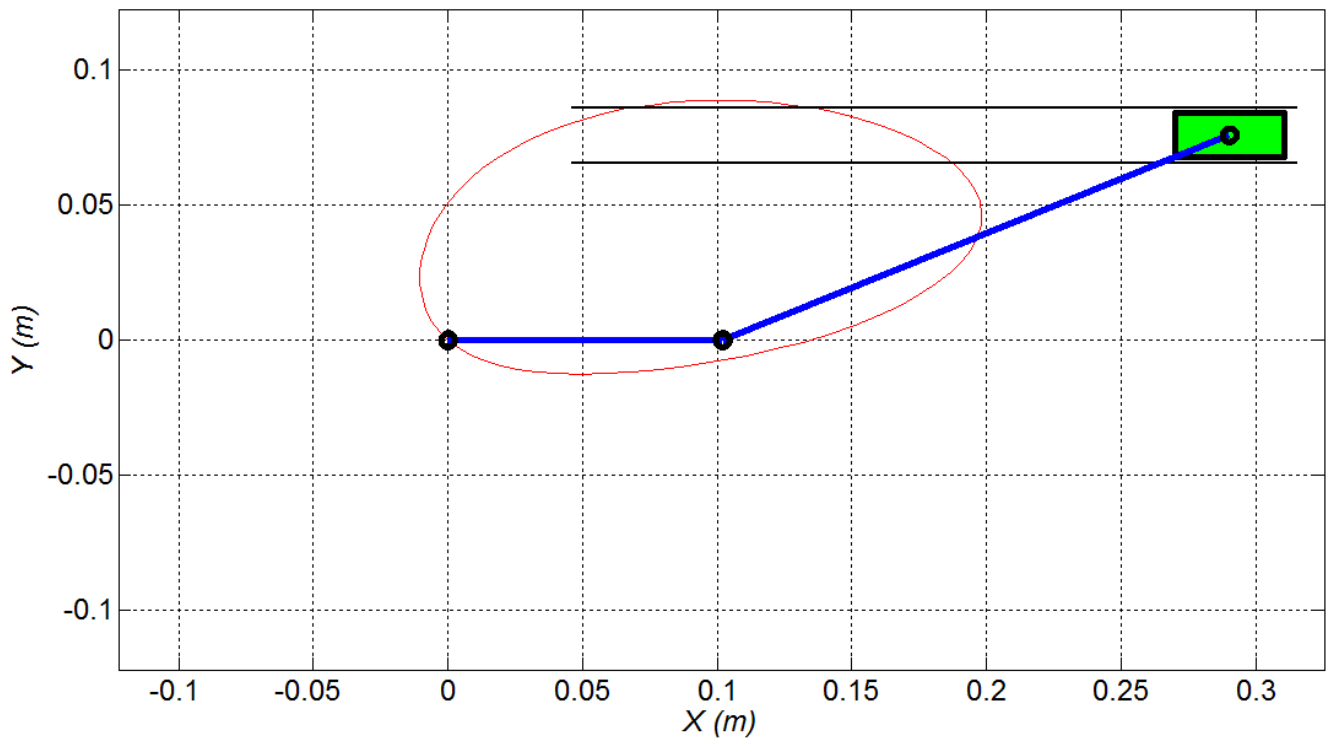

**Slider-Crank Mechanism Coupler Curve**

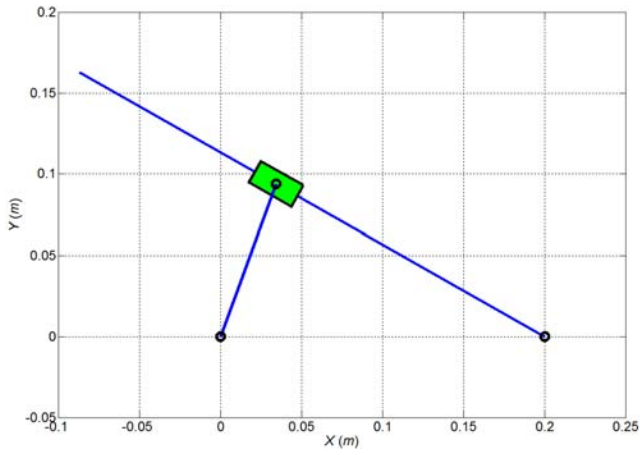

**Slider-Crank Mechanism, Inversion 2**

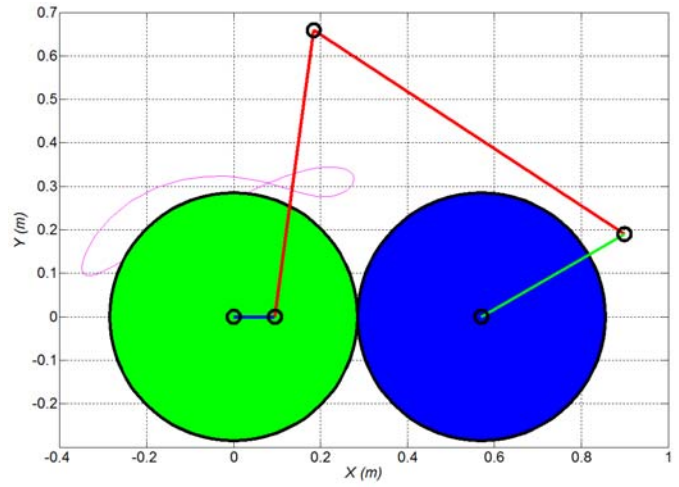

**Geared Five-Bar Mechanism**

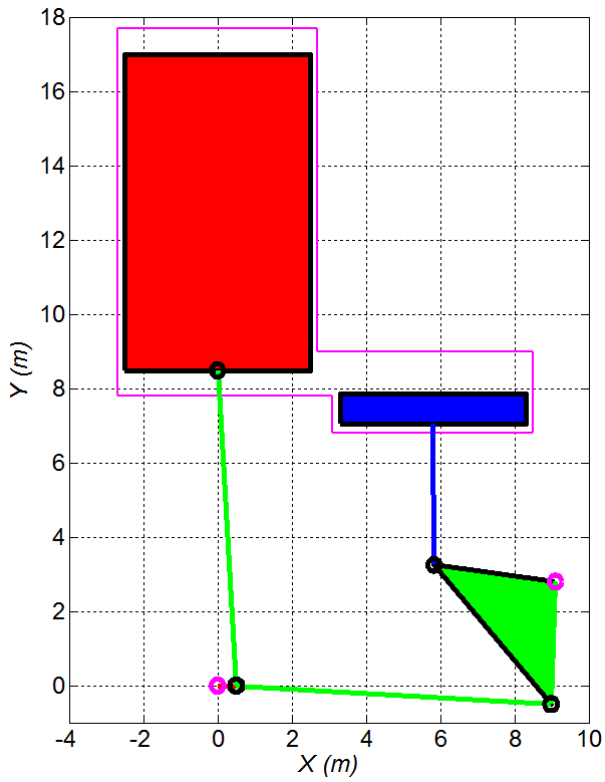

**Ross-Yoke Stirling Engine Mechanism**

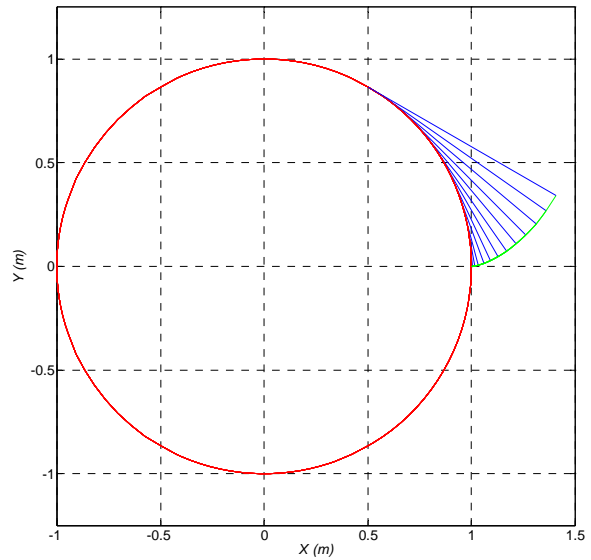

**Involute Gear Tooth Construction**

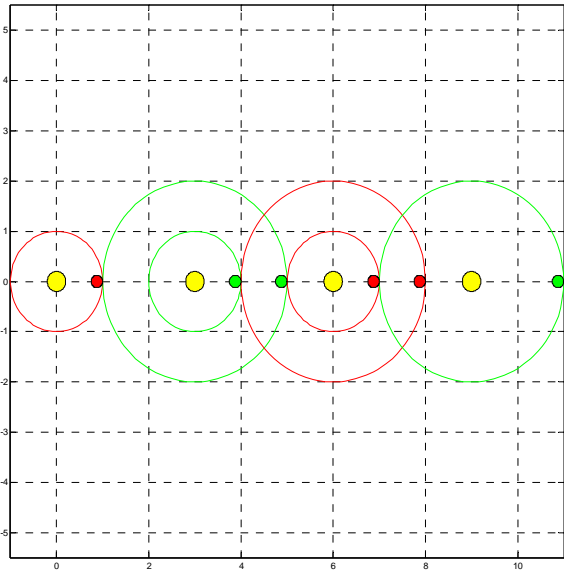

**Gearbox Simulation**

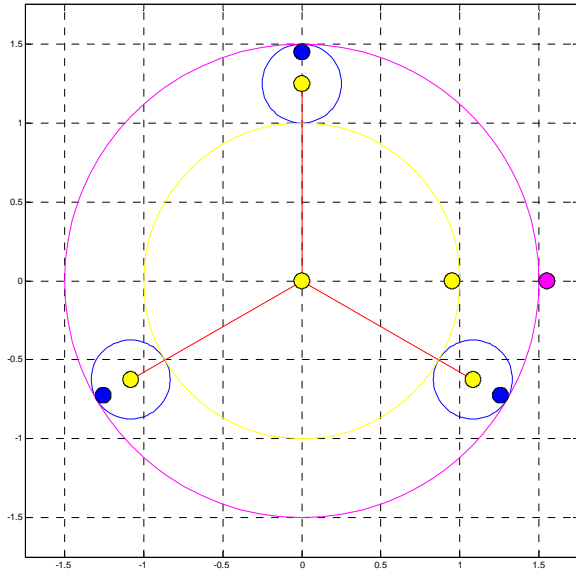

**Planetary Gear Train Simulation**

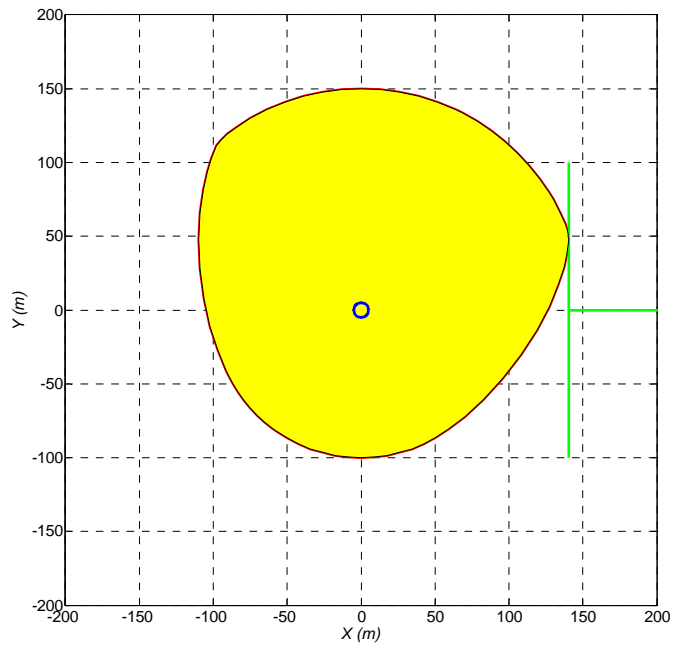

**Cam/Follower Animation**

Mechanical Vibrations

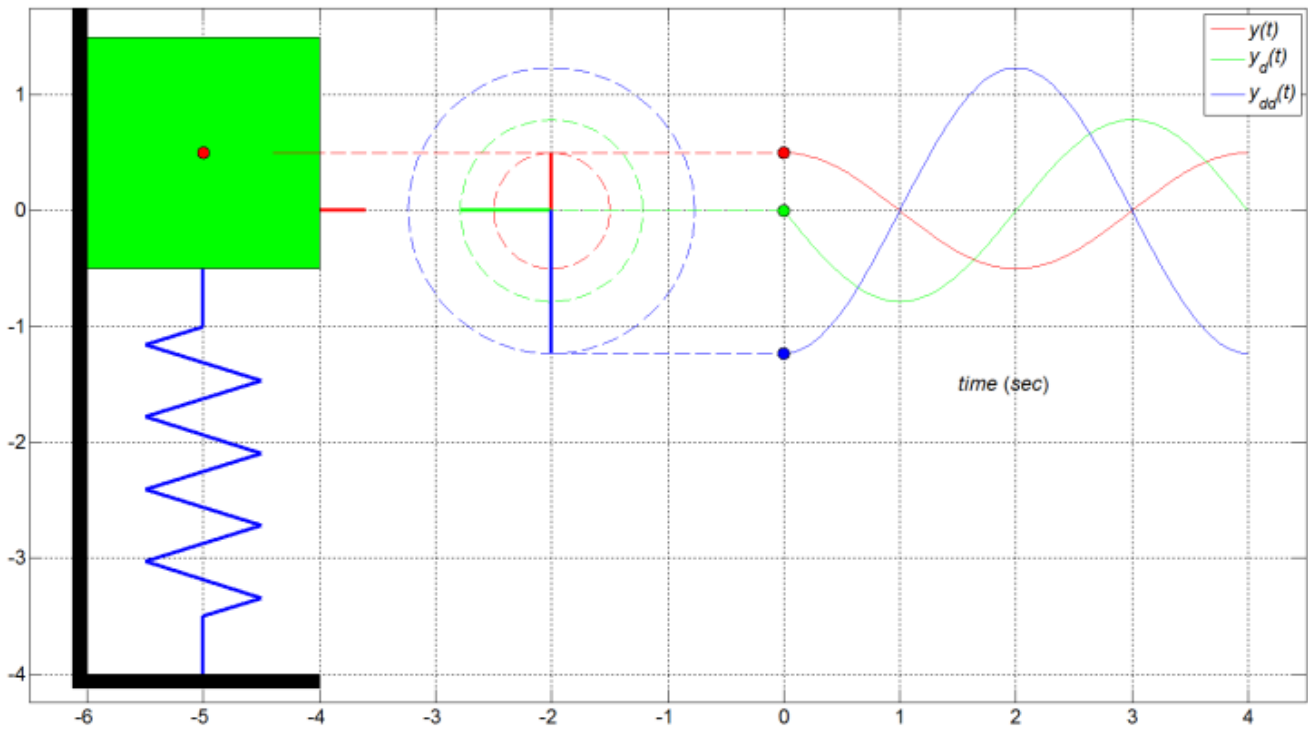

1-dof m-k Vibrational System, Undamped Simple Harmonic Motion, Rotating Phasors

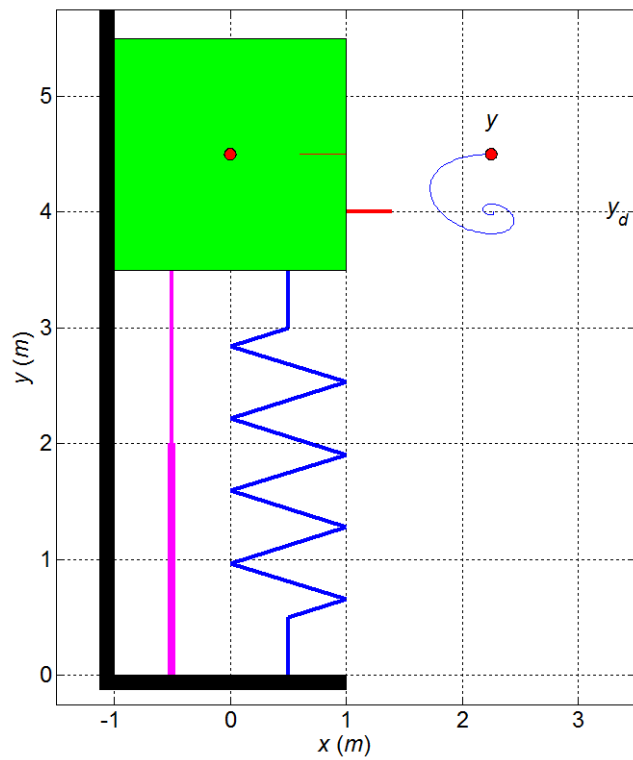

1-dof m-k Vibrational System, Underdamped Response with Phase Plot

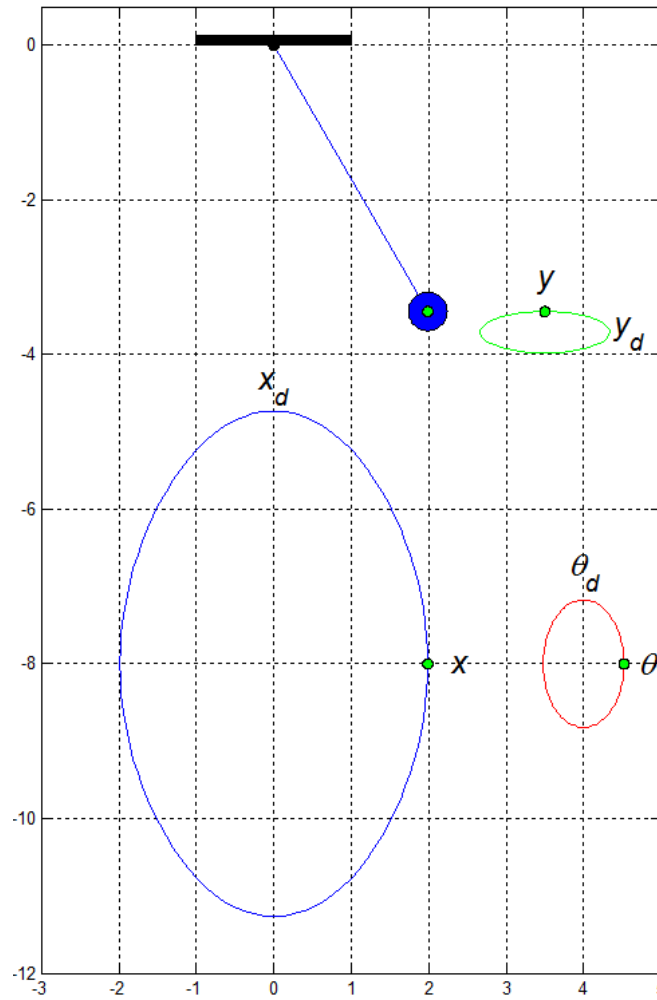

1-dof Pendulum Vibrational System, Simple Harmonic Motion with Phase Plots

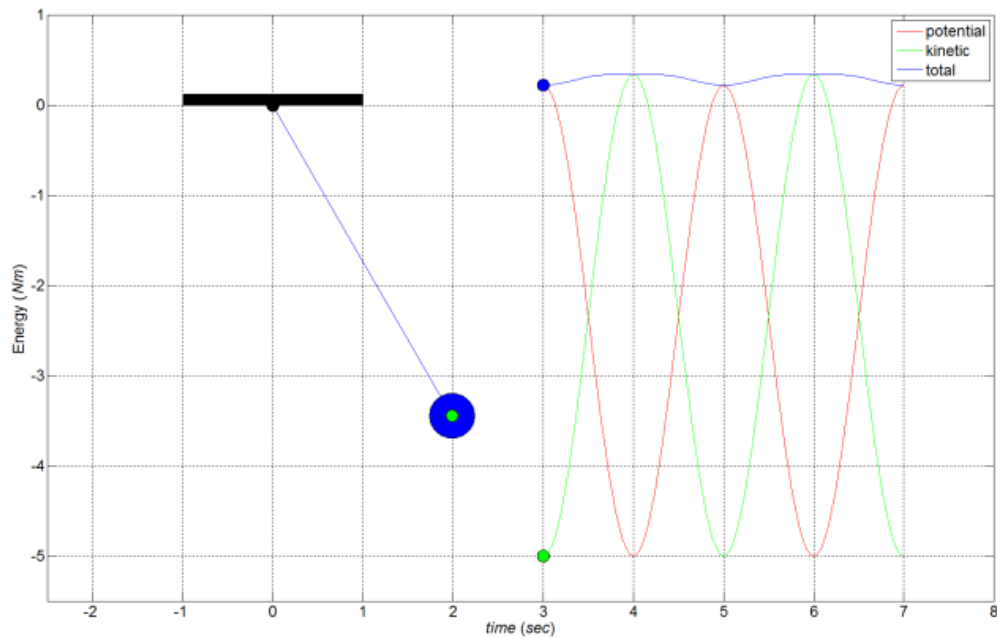

1-dof Pendulum Vibrational System, Simple Harmonic Motion with Energy Plot



## ME 4290/5290 Mechanics of Robotic Manipulators

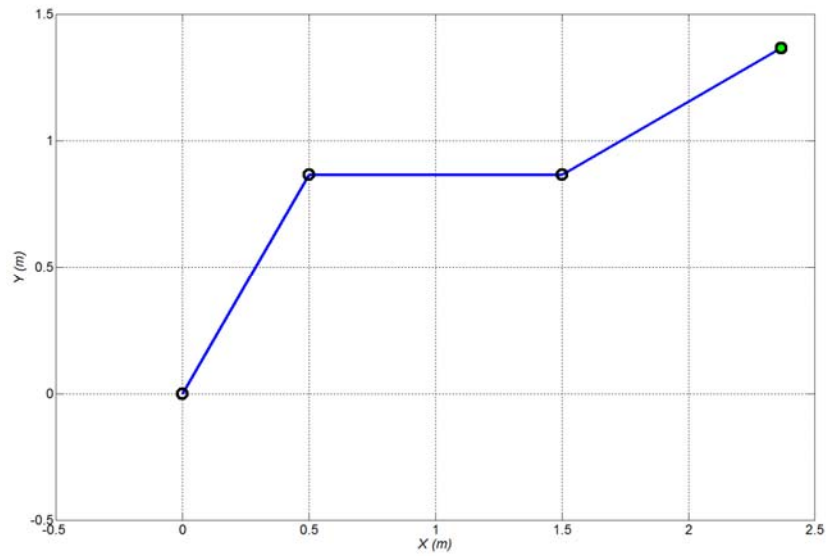

**Planar 3R robot snapshot**

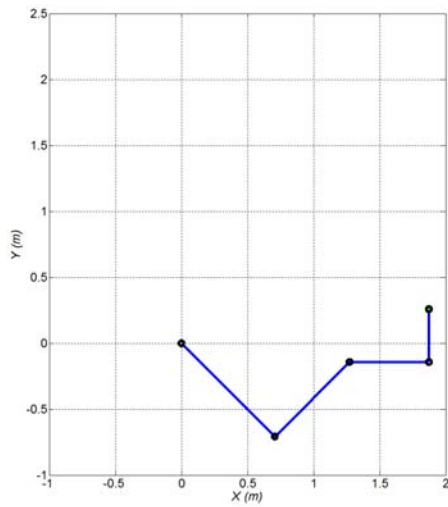

**Initial Robot Pose**

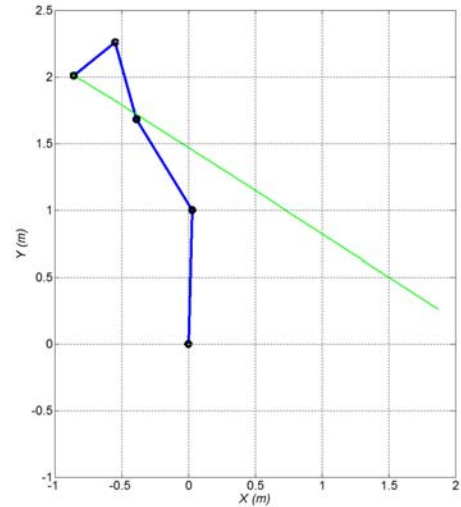

**Final Robot Pose**

## Planar 4R Kinematically-Redundant Robot Resolved-Rate Control Simulation

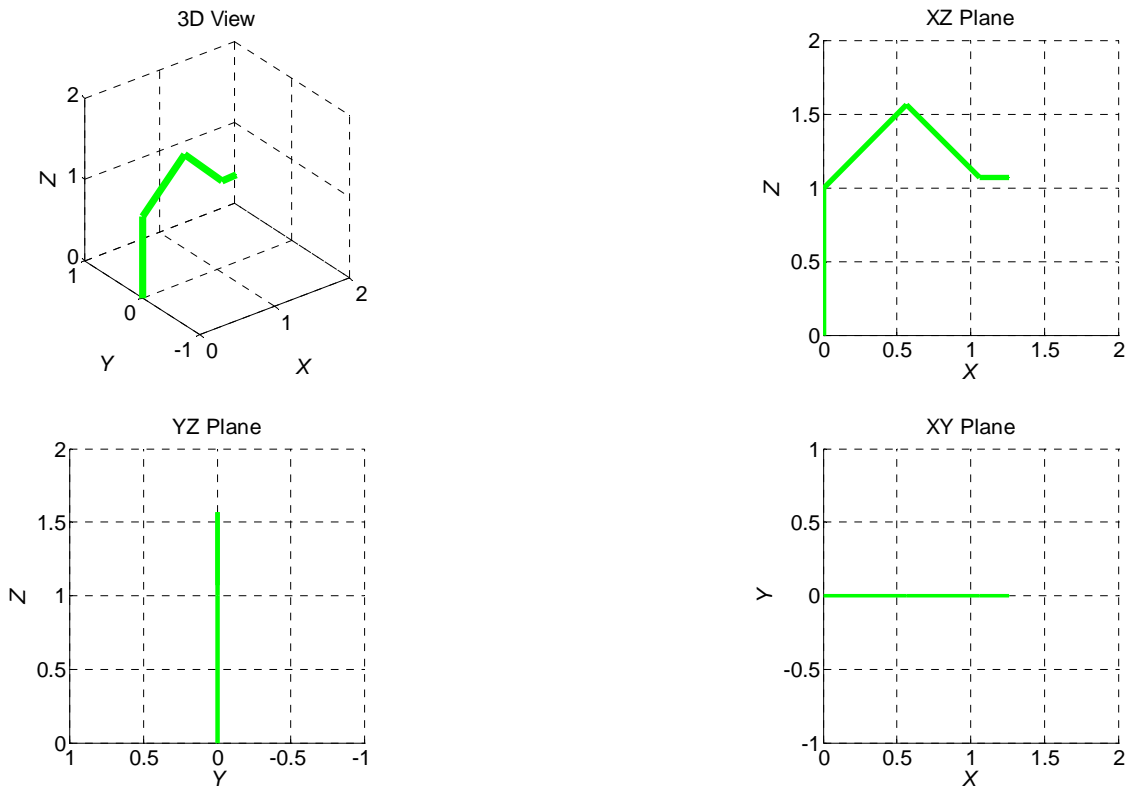

**Spatial 4R Kinematically-Redundant Robot Resolved-Rate Control Simulation**

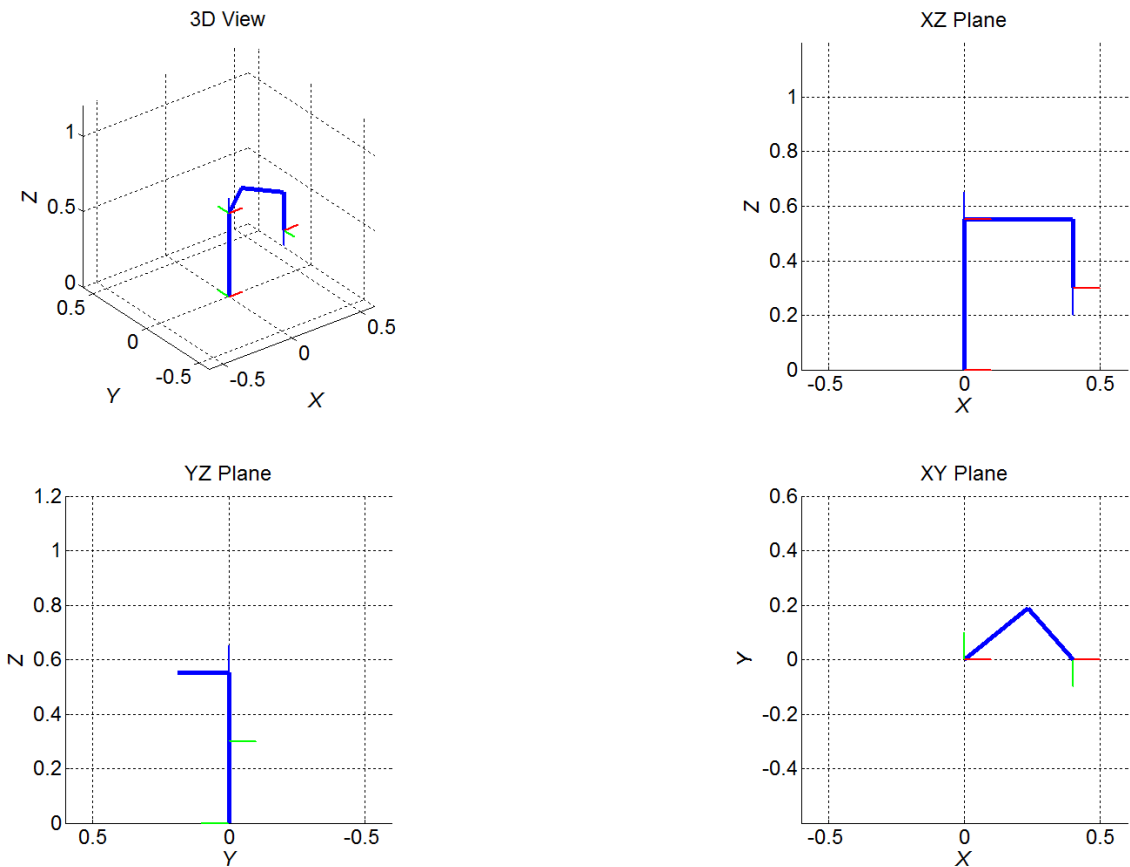

**Adept 550 4-dof SCARA Robot MATLAB Simulation/Animation**

## ME 4670 / BME 5670 Biomechanics of Human Motion

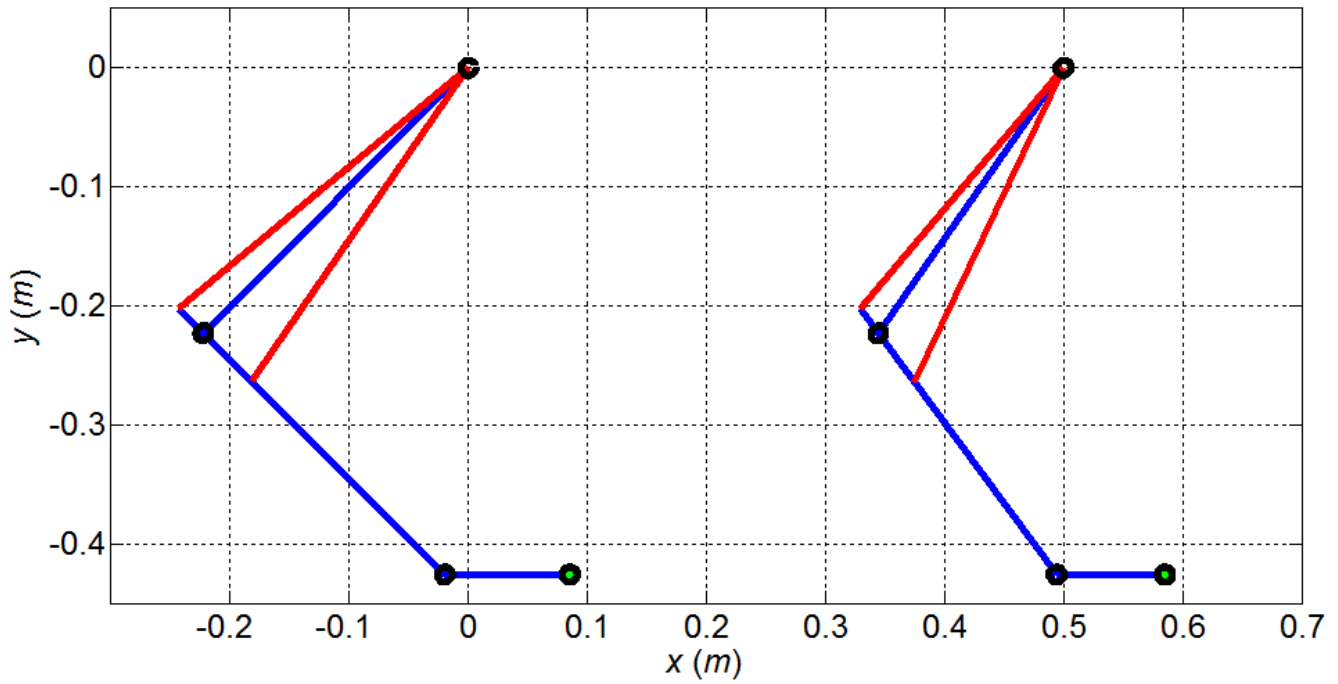

Inverse Pose Kinematics Snapshot  
(male left, female right)

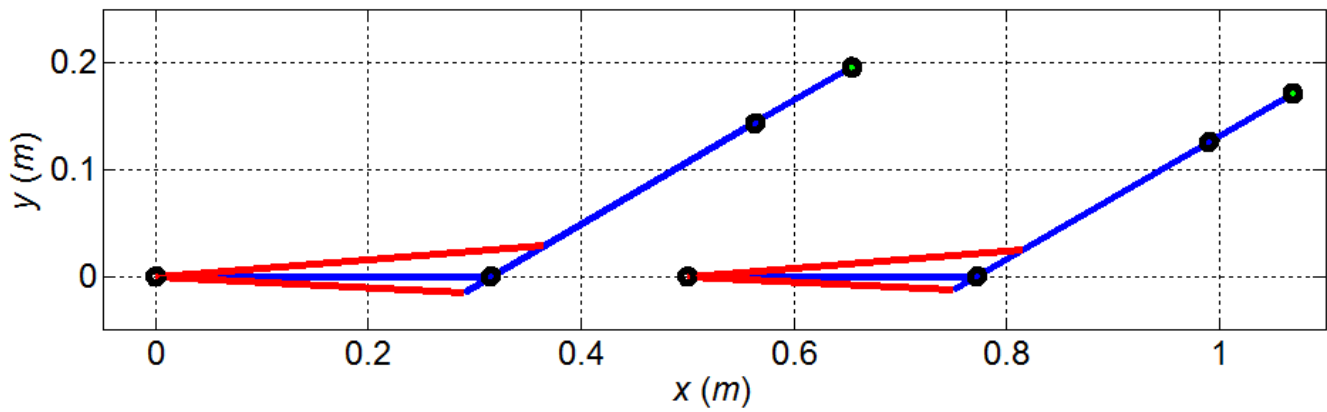

Human Elbow/Biceps/Triceps Dynamic Simulation (male left, female right)