

## Activity 6.4.1: Basic VLSM Calculation and Addressing Design

### Topology Diagram

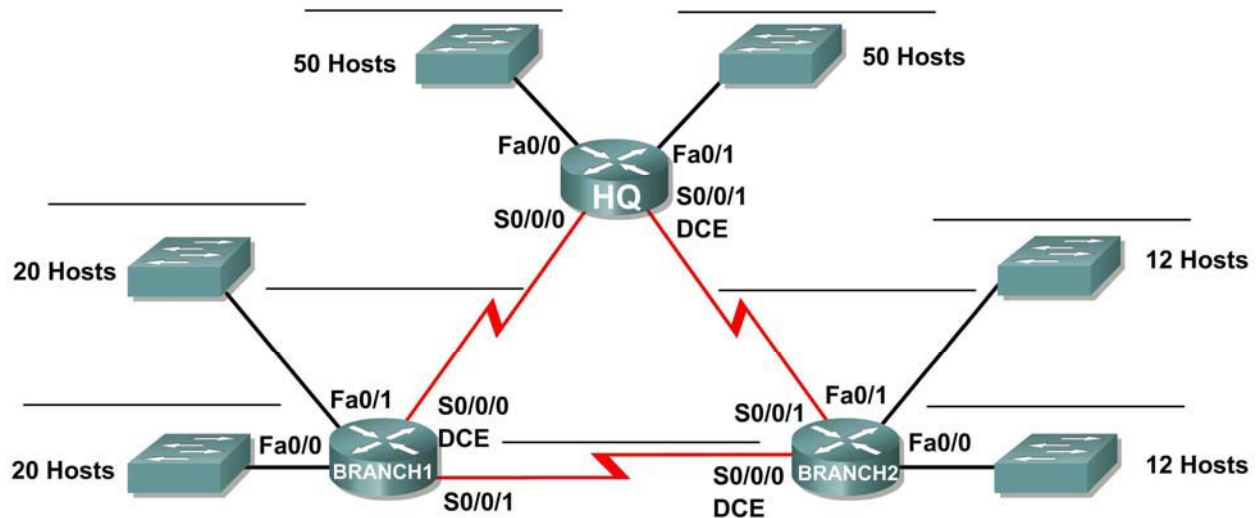

### Addressing Table

Device	Interface	IP Address	Subnet Mask	Default Gateway
HQ	Fa0/0			N/A
	Fa0/1			N/A
	S0/0/0			N/A
	S0/0/1			N/A
Branch1	Fa0/0			N/A
	Fa0/1			N/A
	S0/0/0			N/A
	S0/0/1			N/A
Branch2	Fa0/0			N/A
	Fa0/1			N/A
	S0/0/0			N/A
	S0/0/1			N/A

## Learning Objectives

Upon completion of this activity, you will be able to:

- Determine the number of subnets needed.
- Determine the number of hosts needed for each subnet
- Design an appropriate addressing scheme using VLSM.
- Assign addresses and subnet mask pairs to device interfaces.
- Examine the use of the available network address space.

## Scenario

In this activity, you have been given the network address 192.168.1.0/24 to subnet and provide the IP addressing for the network shown in the Topology Diagram. VLSM will be used so that the addressing requirements can be met using the 192.168.1.0/24 network. The network has the following addressing requirements:

- The HQ LAN1 will require 50 host IP addresses.
- The HQ LAN2 will require 50 host IP addresses.
- The Branch1 LAN1 will require 20 host IP addresses.
- The Branch1 LAN2 will require 20 host IP addresses
- The Branch2 LAN1 will require 12 host IP addresses.
- The Branch2 LAN2 will require 12 host IP addresses.
- The link from HQ to Branch1 will require an IP address for each end of the link.
- The link from HQ to Branch2 will require an IP address for each end of the link.
- The link Branch1 to Branch2 will require an IP address for each end of the link.

**(Note:** Remember that the interfaces of network devices are also host IP addresses and are included in the above addressing requirements.)

## Task 1: Examine the Network Requirements.

Examine the network requirements and answer the questions below. Keep in mind that IP addresses will be needed for each of the LAN interfaces.

1. How many subnets are needed? \_\_\_\_\_
2. What is the maximum number of IP addresses that are needed for a single subnet? \_\_\_\_\_
3. How many IP addresses are needed for each of the BranchBranch1 LANs? \_\_\_\_\_
4. How many IP addresses are needed for each of the BranchBranch2 LANs? \_\_\_\_\_
5. How many IP addresses are needed for each of the WAN links between routers? \_\_\_\_\_
6. What is the total number of IP addresses that are needed? \_\_\_\_\_
7. What is the total number of IP addresses that are available in the 192.168.1.0/24 network?  
\_\_\_\_\_
8. Can the network addressing requirements be met using the 192.168.1.0/24 network? \_\_\_\_\_

## Task 2: Design an IP Addressing Scheme

### Step 1: Determine the subnet information for the largest network segment or segments.

In this case, the two HQ LANs are the largest subnets.

1. How many IP addresses are needed for each LAN? \_\_\_\_\_
2. What is the smallest size subnet that can be used to meet this requirement? \_\_\_\_\_
3. What is the maximum number of IP addresses that can be assigned in this size subnet? \_\_\_\_\_

### Step 2: Assign subnets to HQ LANs.

Start at the beginning of the 192.168.1.0/24 network.

1. Assign the first available subnet to HQ LAN1.
2. Fill in the chart below with the appropriate information.

#### HQ LAN1 Subnet

Network Address	Decimal Subnet Mask	CIDR Subnet Mask	First Usable IP Address	Last Usable IP Address	Broadcast Address

3. Assign the next available subnet to HQ LAN2.
4. Fill in the chart below with the appropriate information.

#### HQ LAN2 Subnet

Network Address	Decimal Subnet Mask	CIDR Subnet Mask	First Usable IP Address	Last Usable IP Address	Broadcast Address

### Step 3: Determine the subnet information for the next largest network segment or segments.

In this case, the two Branch1 LANs are the next largest subnets.

1. How many IP addresses are needed for each LAN? \_\_\_\_\_
2. What is the smallest size subnet that can be used to meet this requirement? \_\_\_\_\_
3. What is the maximum number of IP addresses that can be assigned in this size subnet? \_\_\_\_\_  
30

### Step 4: Assign subnet to BRANCH1 LANs.

Start with the IP address following the HQ LAN subnets.

1. Assign the next subnet to Branch1 LAN1.
2. Fill in the chart below with the appropriate information.

#### Branch1 LAN1 Subnet

Network Address	Decimal Subnet Mask	CIDR Subnet Mask	First Usable IP Address	Last Usable IP Address	Broadcast Address

3. Assign the next available subnet to Branch1 LAN2.

- Fill in the chart below with the appropriate information.

**Branch1 LAN2 Subnet**

Network Address	Decimal Subnet Mask	CIDR Subnet Mask	First Usable IP Address	Last Usable IP Address	Broadcast Address

**Step 5: Determine the subnet information for the next largest network segment or segments.**

In this case, the two Branch2 LANs are the next largest subnets.

- How many IP addresses are needed for each LAN? \_\_\_\_\_
- What is the smallest size subnet that can be used to meet this requirement? \_\_\_\_\_
- What is the maximum number of IP addresses that can be assigned in this size subnet? \_\_\_\_\_

**Step 6: Assign subnets to BRANCH2 LANs.**

Start with the IP address following the Branch1 LAN subnets.

- Assign the next subnet to the Branch2 LAN1. Fill in the chart below with the appropriate information.

**Branch2 LAN1 Subnet**

Network Address	Decimal Subnet Mask	CIDR Subnet Mask	First Usable IP Address	Last Usable IP Address	Broadcast Address

- Assign the next available subnet to Branch2 LAN2.
- Fill in the chart below with the appropriate information.

**Branch2 LAN2 Subnet**

Network Address	Decimal Subnet Mask	CIDR Subnet Mask	First Usable IP Address	Last Usable IP Address	Broadcast Address

**Step 7: Determine the subnet information for the links between the routers.**

- How many IP addresses are needed for each link? \_\_\_\_\_
- What is the smallest size subnet that can be used to meet this requirement? \_\_\_\_\_
- What is the maximum number of IP addresses that can be assigned in this size subnet? \_\_\_\_\_

**Step 8: Assign subnets to links.**

Start with the IP address following the Branch2 LAN subnets.

- Assign the next available subnet to the link between the HQ and Branch1 routers.
- Fill in the chart below with the appropriate information.

**Link between HQ and Branch1 Subnet**

Network Address	Decimal Subnet Mask	CIDR Subnet Mask	First Usable IP Address	Last Usable IP Address	Broadcast Address

3. Assign the next available subnet to the link between the HQ and Branch2 routers.
4. Fill in the chart below with the appropriate information.

**Link between HQ and Branch2 Subnet**

Network Address	Decimal Subnet Mask	CIDR Subnet Mask	First Usable IP Address	Last Usable IP Address	Broadcast Address

5. Assign the next available subnet to the link between the Branch1 and Branch2 routers.
6. Fill in the chart below with the appropriate information.

**Link between Branch1 and Branch2 Subnet**

Network Address	Decimal Subnet Mask	CIDR Subnet Mask	First Usable IP Address	Last Usable IP Address	Broadcast Address

**Task 3: Assign IP Addresses to the Network Devices**

Assign the appropriate addresses to the device interfaces. Document the addresses to be used in the Addressing Table provided under the Topology Diagram.

**Step 1: Assign addresses to the HQ router.**

1. Assign the first valid host address in the HQ LAN 1 subnet to the Fa0/0 LAN interface.
2. Assign the first valid host address in the HQ LAN 2 subnet to the Fa0/1 LAN interface.
3. Assign the first valid host address in the link between HQ and Branch1 subnet to the S0/0/0 interface.
4. Assign the first valid host address in the link between HQ and Branch2 subnet to the S0/0/1 interface.

**Step 2: Assign addresses to the Branch1 router.**

1. Assign the first valid host address in the Branch1 LAN1 subnet to the Fa0/0 LAN interface.
2. Assign the first valid host address in the Branch1 LAN2 subnet to the Fa0/1 LAN interface.
3. Assign the last valid host address on the link between Branch1 and HQ subnet to the S0/0/0 interface
4. Assign the first valid host address on the link between Branch1 and Branch2 subnet to the S0/0/1 interface.

**Step 3: Assign addresses to the Branch2 router.**

1. Assign the first valid host address in the Branch2 LAN1 subnet to the Fa0/0 LAN interface.
2. Assign the first valid host address in the Branch 2 LAN 2 subnet to the Fa0/1 LAN interface.
3. Assign the last valid host address on the link between HQ and Branch2 subnet to the S0/0/1 interface
4. Assign the last valid host address on the link between Branch1 and Branch2 subnet to the S0/0/0 interface.

## Activity 6.4.2: Challenge VLSM Calculation and Addressing Design

### Topology Diagram

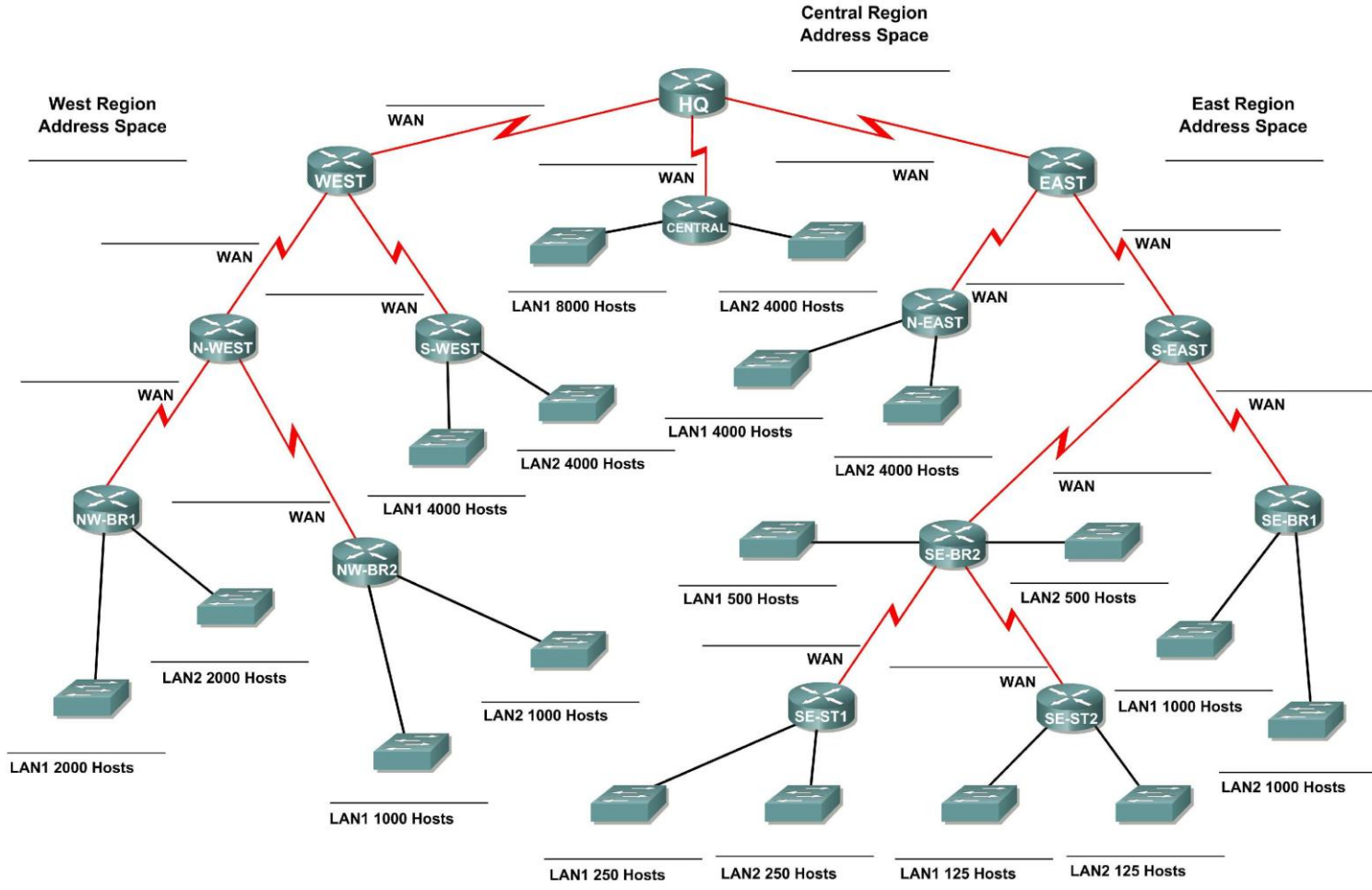

## Learning Objectives

Upon completion of this activity, you will be able to:

- Determine the number of subnets needed.
- Determine the number of hosts needed for each subnet
- Design an appropriate addressing scheme using VLSM.

## Scenario

In this activity, you have been given the network address 172.16.0.0/16 to subnet and provide the IP addressing for the network shown in the Topology Diagram. VLSM will be used so that the addressing requirements can be met using the 172.16.0.0/16 network.

The network has the following addressing requirements:

- East Network Section
  - The N-EAST (Northeast) LAN1 will require 4000 host IP addresses.
  - The N-EAST (Northeast) LAN2 will require 4000 host IP addresses.
  - The SE-BR1 (Southeast Branch1) LAN1 will require 1000 host IP addresses.
  - The SE-BR1 (Southeast Branch1) LAN2 will require 1000 host IP addresses.
  - The SE-BR2 (Southeast Branch2) LAN1 will require 500 host IP addresses.
  - The SE-BR2 (Southeast Branch2) LAN2 will require 500 host IP addresses.
  - The SE-ST1 (Southeast Satellite1) LAN1 will require 250 host IP addresses.
  - The SE-ST1 (Southeast Satellite1) LAN2 will require 250 host IP addresses.
  - The SE-ST2 (Southeast Satellite2) LAN1 will require 125 host IP addresses.
  - The SE-ST2 (Southeast Satellite2) LAN2 will require 125 host IP addresses.
- West Network Section
  - The S-WEST (Southwest) LAN1 will require 4000 host IP addresses.
  - The S-WEST (Southwest) LAN2 will require 4000 host IP addresses.
  - The NW-BR1 (Northwest Branch1) LAN1 will require 2000 host IP addresses.
  - The NW-BR1 (Northwest Branch1) LAN2 will require 2000 host IP addresses.
  - The NW-BR2 (Northwest Branch2) LAN1 will require 1000 host IP addresses.
  - The NW-BR2 (Northwest Branch2) LAN2 will require 1000 host IP addresses.
- Central Network Section
  - The Central LAN1 will require 8000 host IP addresses.
  - The Central LAN2 will require 4000 host IP addresses.
- The WAN links between each of the routers will require an IP address for each end of the link.

**(Note:** Remember that the interfaces of network devices are also host IP addresses and are included in the above addressing requirements.)

## Task 1: Examine the Network Requirements.

Examine the network requirements and answer the questions below. Keep in mind that IP addresses will be needed for each of the LAN interfaces.

1. How many LAN subnets are needed? \_\_\_\_\_
2. How many subnets are needed for the WAN links between routers? \_\_\_\_\_

3. How many total subnets are needed? \_\_\_\_\_
4. What is the maximum number of host IP addresses that are needed for a single subnet? \_\_\_\_\_
5. What is the least number of host IP addresses that are needed for a single subnet? \_\_\_\_\_
6. How many IP addresses are needed for the East portion of the network? Be sure to include the WAN links between the routers. \_\_\_\_\_
7. How many IP addresses are needed for the West portion of the network? Be sure to include the WAN links between the routers. \_\_\_\_\_
8. How many IP addresses are needed for the Central portion of the network? Be sure to include the WAN links between the routers. \_\_\_\_\_
9. What is the total number of IP addresses that are needed? \_\_\_\_\_
10. What is the total number of IP addresses that are available in the 172.16.0.0/16 network?  
\_\_\_\_\_
11. Can the network addressing requirements be met using the 172.16.0.0/16 network? \_\_\_\_\_

**Task 2: Divide the Network into Three Subnetworks.**

**Step 1: Determine the subnet information for each network section.**

To keep the subnets of each of the major network sections contiguous, begin by creating a main subnet for each of the East, West, and Central network sections.

1. What is the smallest size subnet that can be used to meet the addressing requirement for the East network? \_\_\_\_\_
2. What is the maximum number of IP addresses that can be assigned in this size subnet? \_\_\_\_\_
3. What is the smallest size subnet that can be used to meet the addressing requirement for the West network? \_\_\_\_\_
4. What is the maximum number of IP addresses that can be assigned in this size subnet? \_\_\_\_\_
5. What is the smallest size subnet that can be used to meet the addressing requirement for the Central network? \_\_\_\_\_
6. What is the maximum number of IP addresses that can be assigned in this size subnet? \_\_\_\_\_

**Step 2: Assign subnets.**

1. Start at the beginning of the 172.16.0.0/16 network. Assign the first available subnet to the East section of the network.
2. Fill in the chart below with the appropriate information.

**East Subnet**

Network Address	Decimal Subnet Mask	CIDR Subnet Mask	First Usable IP Address	Last Usable IP Address	Broadcast Address

3. Assign the next available subnet to the West section of the network.
4. Fill in the chart below with the appropriate information.



**West Subnet**

Network Address	Decimal Subnet Mask	CIDR Subnet Mask	First Usable IP Address	Last Usable IP Address	Broadcast Address

5. Assign the next available subnet to the Central section of the network.
6. Fill in the chart below with the appropriate information.

**Central Subnet**

Network Address	Decimal Subnet Mask	CIDR Subnet Mask	First Usable IP Address	Last Usable IP Address	Broadcast Address

**Task 3: Design an IP Addressing Scheme for the Central Network.**

**Step 1: Determine the subnet information for the Central LAN1.**

Use the address space that was designated for the Central network in Task 1.

1. What is the smallest size subnet that can be used to meet this requirement? \_\_\_\_\_
2. What is the maximum number of IP addresses that can be assigned in this size subnet? \_\_\_\_\_

**Step 2: Assign subnet to Central LAN1.**

Start at the beginning of the address space designated for the Central network.

1. Assign the first subnet to the Central LAN1.
2. Fill in the chart below with the appropriate information.

**Central LAN1 Subnet**

Network Address	Decimal Subnet Mask	CIDR Subnet Mask	First Usable IP Address	Last Usable IP Address	Broadcast Address

**Step 3: Determine the subnet information for the Central LAN2.**

1. What is the smallest size subnet that can be used to meet this requirement? \_\_\_\_\_
2. What is the maximum number of IP addresses that can be assigned in this size subnet? \_\_\_\_\_

**Step 4: Assign subnet to Central LAN2.**

1. Assign the next available subnet to the Central LAN2.
2. Fill in the chart below with the appropriate information.

**Central LAN2 Subnet**

Network Address	Decimal Subnet Mask	CIDR Subnet Mask	First Usable IP Address	Last Usable IP Address	Broadcast Address

**Step 5: Determine the subnet information for the WAN link between the Central router and the HQ router.**

1. What is the smallest size subnet that can be used to meet this requirement? \_\_\_\_\_
2. What is the maximum number of IP addresses that can be assigned in this size subnet? \_\_\_\_\_

**Step 6: Assign subnet to WAN link.**

1. Assign the next available subnet to the WAN link between the Central router and the HQ router.
2. Fill in the chart below with the appropriate information.

**WAN link between Central and HQ Subnet**

Network Address	Decimal Subnet Mask	CIDR Subnet Mask	First Usable IP Address	Last Usable IP Address	Broadcast Address

**Task 4: Design an IP Addressing Scheme for the West Network.**

**Step 1: Determine the subnet information for the S-WEST LAN1.**

Use the address space that was designated for the West network in Task 1.

1. What is the smallest size subnet that can be used to meet this requirement? \_\_\_\_\_
2. What is the maximum number of IP addresses that can be assigned in this size subnet? \_\_\_\_\_

**Step 2: Assign subnet to S-WEST LAN1.**

Start at the beginning of the address space designated for the West network.

1. Assign the first subnet to the S-WEST LAN1.
2. Fill in the chart below with the appropriate information.

**S-WEST LAN1 Subnet**

Network Address	Decimal Subnet Mask	CIDR Subnet Mask	First Usable IP Address	Last Usable IP Address	Broadcast Address

**Step 3: Determine the subnet information for the S-WEST LAN2.**

1. What is the smallest size subnet that can be used to meet this requirement? \_\_\_\_\_
2. What is the maximum number of IP addresses that can be assigned in this size subnet? \_\_\_\_\_

**Step 4: Assign subnet to S-WEST LAN2.**

1. Assign the next available subnet to the S-WEST LAN2.
2. Fill in the chart below with the appropriate information.

**S-WEST LAN2 Subnet**

Network Address	Decimal Subnet Mask	CIDR Subnet Mask	First Usable IP Address	Last Usable IP Address	Broadcast Address

**Step 5: Determine the subnet information for the NW-BR1 LAN1.**

1. What is the smallest size subnet that can be used to meet this requirement? \_\_\_\_\_
2. What is the maximum number of IP addresses that can be assigned in this size subnet? \_\_\_\_\_

**Step 6: Assign subnet to NW-BR1 LAN1.**

1. Assign the next available subnet to the NW-BR1 LAN1.
2. Fill in the chart below with the appropriate information.

**NW-BR1 LAN1 Subnet**

Network Address	Decimal Subnet Mask	CIDR Subnet Mask	First Usable IP Address	Last Usable IP Address	Broadcast Address

**Step 7: Determine the subnet information for the NW-BR1 LAN2.**

1. What is the smallest size subnet that can be used to meet this requirement? \_\_\_\_\_
2. What is the maximum number of IP addresses that can be assigned in this size subnet? \_\_\_\_\_

**Step 8: Assign subnet to NW-BR1 LAN2.**

1. Assign the next available subnet to the NW-BR1 LAN2.
2. Fill in the chart below with the appropriate information.

**NW-BR1 LAN2 Subnet**

Network Address	Decimal Subnet Mask	CIDR Subnet Mask	First Usable IP Address	Last Usable IP Address	Broadcast Address

**Step 9: Determine the subnet information for the NW-BR2 LAN1.**

1. What is the smallest size subnet that can be used to meet this requirement? \_\_\_\_\_
2. What is the maximum number of IP addresses that can be assigned in this size subnet? \_\_\_\_\_

**Step 10: Assign subnet to NW-BR2 LAN1.**

1. Assign the next available subnet to the NW-BR2 LAN1.
2. Fill in the chart below with the appropriate information.

**NW-BR2 LAN1 Subnet**

Network Address	Decimal Subnet Mask	CIDR Subnet Mask	First Usable IP Address	Last Usable IP Address	Broadcast Address

**Step 11: Determine the subnet information for the NW-BR2 LAN2.**

1. What is the smallest size subnet that can be used to meet this requirement? \_\_\_\_\_
2. What is the maximum number of IP addresses that can be assigned in this size subnet? \_\_\_\_\_

**Step 12: Assign subnet to NW-BR2 LAN2.**

1. Assign the next available subnet to the NW-BR2 LAN2.
2. Fill in the chart below with the appropriate information.

**NW-BR2 LAN2 Subnet**

Network Address	Decimal Subnet Mask	CIDR Subnet Mask	First Usable IP Address	Last Usable IP Address	Broadcast Address

**Step 13: Determine the subnet information for the WAN links between the routers in the West network.**

1. How many router to router WAN links are present in the West network? \_\_\_\_\_
2. How many IP addresses are needed for each of these WAN links? \_\_\_\_\_
3. What is the smallest size subnet that can be used to meet this requirement? \_\_\_\_\_
4. What is the maximum number of IP addresses that can be assigned in this size subnet? \_\_\_\_\_

**Step 14: Assign subnets to WAN links.**

1. Assign the next available subnets to the WAN links between the routers.
2. Fill in the chart below with the appropriate information.

**WAN links between the Routers in the West Network**

WAN Link	Network Address	Decimal Subnet Mask	CIDR Subnet Mask	First Usable IP Address	Last Usable IP Address	Broadcast Address
HQ to WEST						
WEST to S-WEST						
WEST to N-WEST						
N-WEST to NW-BR1						
N-WEST to NW-BR2						

**Task 5: Design an IP Addressing Scheme for the East Network.**

**Step 1: Determine the subnet information for the N-EAST LAN1.**

Use the address space that was designated for the East network in Task 1.

1. What is the smallest size subnet that can be used to meet this requirement? \_\_\_\_\_
2. What is the maximum number of IP addresses that can be assigned in this size subnet? \_\_\_\_\_

**Step 2: Assign subnet to N-EAST LAN1.**

Start at the beginning of the address space designated for the East network.

1. Assign the first subnet to the N-EAST LAN1.

- Fill in the chart below with the appropriate information.

**N-EAST LAN1 Subnet**

Network Address	Decimal Subnet Mask	CIDR Subnet Mask	First Usable IP Address	Last Usable IP Address	Broadcast Address

**Step 3: Determine the subnet information for the N-EAST LAN2.**

- What is the smallest size subnet that can be used to meet this requirement? \_\_\_\_\_
- What is the maximum number of IP addresses that can be assigned in this size subnet? \_\_\_\_\_

**Step 4: Assign subnet to N-EAST LAN2.**

- Assign the next available subnet to the N-EAST LAN2.
- Fill in the chart below with the appropriate information.

**N-EAST LAN2 Subnet**

Network Address	Decimal Subnet Mask	CIDR Subnet Mask	First Usable IP Address	Last Usable IP Address	Broadcast Address

**Step 5: Determine the subnet information for the SE-BR1 LAN1.**

- What is the smallest size subnet that can be used to meet this requirement? \_\_\_\_\_
- What is the maximum number of IP addresses that can be assigned in this size subnet? \_\_\_\_\_

**Step 6: Assign subnet to SE-BR1 LAN1.**

- Assign the next available subnet to the SE-BR1 LAN1.
- Fill in the chart below with the appropriate information.

**SE-BR1 LAN1 Subnet**

Network Address	Decimal Subnet Mask	CIDR Subnet Mask	First Usable IP Address	Last Usable IP Address	Broadcast Address

**Step 7: Determine the subnet information for the SE-BR1 LAN2.**

- What is the smallest size subnet that can be used to meet this requirement? \_\_\_\_\_
- What is the maximum number of IP addresses that can be assigned in this size subnet? \_\_\_\_\_

**Step 8: Assign subnet to SE-BR1 LAN2.**

- Assign the next available subnet to the SE-BR1 LAN2.

- Fill in the chart below with the appropriate information.

**SE-BR1 LAN2 Subnet**

Network Address	Decimal Subnet Mask	CIDR Subnet Mask	First Usable IP Address	Last Usable IP Address	Broadcast Address

**Step 9: Determine the subnet information for the SE-BR2 LAN1.**

- What is the smallest size subnet that can be used to meet this requirement? \_\_\_\_\_
- What is the maximum number of IP addresses that can be assigned in this size subnet? \_\_\_\_\_

**Step 10: Assign subnet to SE-BR2 LAN1.**

- Assign the next available subnet to the SE-BR2 LAN1.
- Fill in the chart below with the appropriate information.

**SE-BR2 LAN1 Subnet**

Network Address	Decimal Subnet Mask	CIDR Subnet Mask	First Usable IP Address	Last Usable IP Address	Broadcast Address

**Step 11: Determine the subnet information for the SE-BR2 LAN2.**

- What is the smallest size subnet that can be used to meet this requirement? \_\_\_\_\_
- What is the maximum number of IP addresses that can be assigned in this size subnet? \_\_\_\_\_

**Step 12: Assign subnet to SE-BR2 LAN2.**

- Assign the next available subnet to the SE-BR2 LAN2.
- Fill in the chart below with the appropriate information.

**SE-BR2 LAN2 Subnet**

Network Address	Decimal Subnet Mask	CIDR Subnet Mask	First Usable IP Address	Last Usable IP Address	Broadcast Address

**Step 13: Determine the subnet information for the SE-ST1 LAN1.**

- What is the smallest size subnet that can be used to meet this requirement? \_\_\_\_\_
- What is the maximum number of IP addresses that can be assigned in this size subnet? \_\_\_\_\_

**Step 14: Assign subnet to SE-ST1 LAN1.**

- Assign the next available subnet to the SE-ST1 LAN1.

- Fill in the chart below with the appropriate information.

**SE-ST1 LAN1 Subnet**

Network Address	Decimal Subnet Mask	CIDR Subnet Mask	First Usable IP Address	Last Usable IP Address	Broadcast Address

**Step 15: Determine the subnet information for the SE-ST1 LAN2.**

- What is the smallest size subnet that can be used to meet this requirement? \_\_\_\_\_
- What is the maximum number of IP addresses that can be assigned in this size subnet? \_\_\_\_\_

**Step 16: Assign subnet to SE-ST1 LAN2.**

- Assign the next available subnet to the SE-ST1 LAN2.
- Fill in the chart below with the appropriate information.

**SE-ST1 LAN2 Subnet**

Network Address	Decimal Subnet Mask	CIDR Subnet Mask	First Usable IP Address	Last Usable IP Address	Broadcast Address

**Step 17: Determine the subnet information for the SE-ST2 LAN1.**

- What is the smallest size subnet that can be used to meet this requirement? \_\_\_\_\_
- What is the maximum number of IP addresses that can be assigned in this size subnet? \_\_\_\_\_

**Step 18: Assign subnet to SE-ST2 LAN1.**

- Assign the next available subnet to the SE-ST2 LAN1.
- Fill in the chart below with the appropriate information.

**SE-ST2 LAN1 Subnet**

Network Address	Decimal Subnet Mask	CIDR Subnet Mask	First Usable IP Address	Last Usable IP Address	Broadcast Address

**Step 19: Determine the subnet information for the SE-ST2 LAN2.**

- What is the smallest size subnet that can be used to meet this requirement? \_\_\_\_\_
- What is the maximum number of IP addresses that can be assigned in this size subnet? \_\_\_\_\_

**Step 20: Assign subnet to SE-ST2 LAN2.**

- Assign the next available subnet to the SE-ST2 LAN2.

- Fill in the chart below with the appropriate information.

**SE-ST2 LAN2 Subnet**

Network Address	Decimal Subnet Mask	CIDR Subnet Mask	First Usable IP Address	Last Usable IP Address	Broadcast Address

**Step 21: Determine the subnet information for the WAN links between the routers in the East network.**

- How many router to router WAN links are present in the East network? \_\_\_\_\_
- How many IP addresses are needed for each of these WAN links? \_\_\_\_\_
- What is the smallest size subnet that can be used to meet this requirement? \_\_\_\_\_
- What is the maximum number of IP addresses that can be assigned in this size subnet? \_\_\_\_\_

**Step 22: Assign subnets to WAN links.**

- Assign the next available subnets to the WAN links between the routers.
- Fill in the chart below with the appropriate information.

**WAN links between the Routers in the East Network**

WAN link	Network Address	Decimal Subnet Mask	CIDR Subnet Mask	First Usable IP Address	Last Usable IP Address	Broadcast Address
HQ to EAST						
EAST to S-EAST						
EAST to N-EAST						
S-EAST to SE-BR1						
S-EAST to SE-BR2						
SE-BR2 to SE-ST1						
SE-BR2 to SE-ST2						



## Activity 6.4.3: Troubleshooting a VLSM Addressing Design

### Topology Diagram

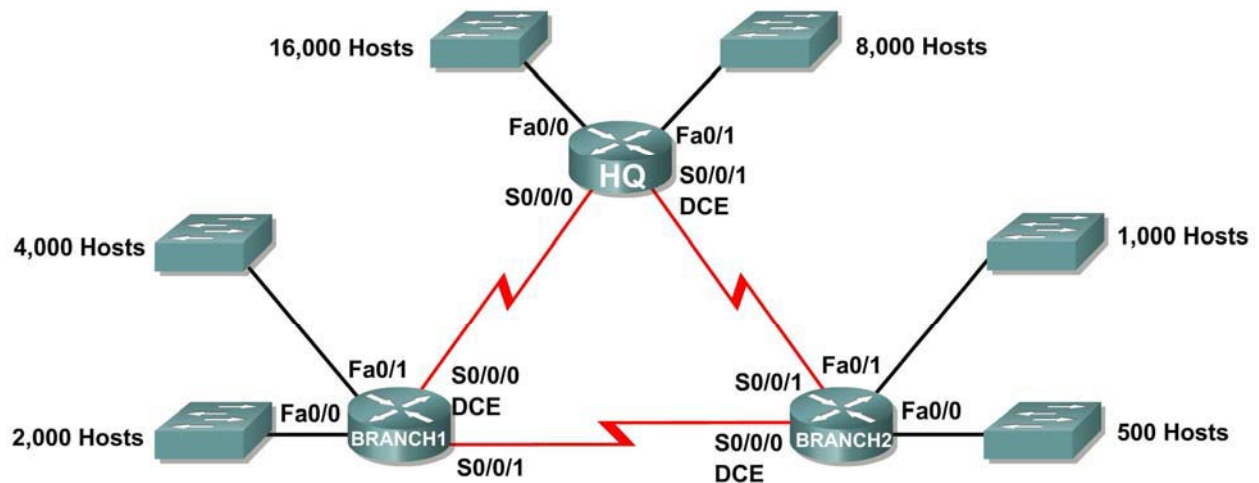

### Addressing Table

Subnet	Number of IP Addresses Needed	Network Address
HQ LAN1	16,000	172.16.128.0/19
HQ LAN2	8,000	172.16.192.0/18
Branch1 LAN1	4,000	172.16.224.0/20
Branch1 LAN2	2,000	172.16.240.0/21
Branch2 LAN1	1,000	172.16.244.0/24
Branch2 LAN2	500	172.16.252.0/23
Link from HQ to Branch1	2	172.16.254.0/28
Link from HQ to Branch2	2	172.16.154.6/30
Link from Branch1 to Branch2	2	172.16.254.8/30

### Learning Objectives

Upon completion of this activity, you will be able to:

- Discover errors in a VLSM design.
- Propose solutions for VLSM design errors.
- Document the corrected VLSM assignments.

## Scenario

In this activity, the network address 172.16.128.0/17 has been used to provide the IP addressing for the network shown in the Topology Diagram. VLSM has been used to subnet the address space incorrectly. You will need to troubleshoot the addressing that has been assigned for each subnet to determine where errors are present and then determine the correct addressing assignments, where needed.

### Task 1: Examine the Addressing for the HQ LANs.

**Step 1: Examine the addressing assignment for the HQ LAN1 subnet and answer the questions below:**

1. How many IP addresses are needed for the HQ LAN1 subnet? \_\_\_\_\_
2. How many IP addresses are available in the currently assigned subnet? \_\_\_\_\_
3. Will the currently assigned subnet fulfill the size requirement for the HQ LAN1 subnet? \_\_\_\_\_
4. If the answer to the previous question is **no**, propose a new subnet mask that will allow for the correct number of IP addresses. \_\_\_\_\_
5. Does the subnet overlap with any of the other currently assigned networks? \_\_\_\_\_
6. If the answer to the previous question is **yes**, propose a new subnet mask that will allow for the correct number of IP addresses without overlapping into any other subnets.  
\_\_\_\_\_

**Step 2: Examine the addressing assignment for the HQ LAN2 subnet and answer the questions below.**

1. How many IP addresses are needed for the HQ LAN2 subnet? \_\_\_\_\_
2. How many IP addresses are available in the currently assigned subnet? \_\_\_\_\_
3. Will the currently assigned subnet fulfill the size requirement for the HQ LAN2 subnet? \_\_\_\_\_
4. If the answer to the previous question is **no**, propose a new subnet mask that will allow for the correct number of IP addresses. \_\_\_\_\_
5. Does the subnet overlap with any of the other currently assigned networks? \_\_\_\_\_
6. If the answer to the previous question is **yes**, propose a new subnet mask that will allow for the correct number of IP addresses without overlapping into any other subnets.  
\_\_\_\_\_

### Task 2: Examine the Addressing for the Branch1 LANs.

**Step 1: Examine the addressing assignment for the Branch1 LAN1 subnet and answer the questions below.**

1. How many IP addresses are needed for the Branch1 LAN1 subnet? \_\_\_\_\_
2. How many IP addresses are available in the currently assigned subnet? \_\_\_\_\_
3. Will the currently assigned subnet fulfill the size requirement for the Branch1 LAN1 subnet?  
\_\_\_\_\_
4. If the answer to the previous question is **no**, propose a new subnet mask that will allow for the correct number of IP addresses. \_\_\_\_\_

5. Does the subnet overlap with any of the other currently assigned networks? \_\_\_\_\_
6. If the answer to the previous question is **yes**, propose a new subnet mask that will allow for the correct number of IP addresses without overlapping into any other subnets.  
\_\_\_\_\_

**Step 2: Examine the addressing assignment for the Branch1 LAN2 and answer the questions below.**

1. How many IP addresses are needed for the Branch1 LAN2 subnet? \_\_\_\_\_
2. How many IP addresses are available in the currently assigned subnet? \_\_\_\_\_
3. Will the currently assigned subnet fulfill the size requirement for the Branch1 LAN2 subnet?  
\_\_\_\_\_
4. If the answer to the previous question is **no**, propose a new subnet mask that will allow for the correct number of IP addresses. \_\_\_\_\_
5. Does the subnet overlap with any of the other currently assigned networks? \_\_\_\_\_
6. If the answer to the previous question is **yes**, propose a new network address that will allow for the correct number of IP addresses without overlapping into any other subnets.  
\_\_\_\_\_

**Task 3: Examine the Addressing for the Branch2 LANs.**

**Step 1: Examine the addressing assignment for the Branch2 LAN1 subnet and answer the questions below.**

1. How many IP addresses are needed for the Branch2 LAN1 subnet? \_\_\_\_\_
2. How many IP addresses are available in the currently assigned subnet? \_\_\_\_\_
3. Will the currently assigned subnet fulfill the size requirement for the Branch2 LAN1 subnet?  
\_\_\_\_\_
4. If the answer to the previous question is **no**, propose a new subnet mask that will allow for the correct number of IP addresses. \_\_\_\_\_
5. Does the subnet overlap with any of the other currently assigned networks? \_\_\_\_\_
6. If the answer to the previous question is **yes**, propose a new subnet mask that will allow for the correct number of IP addresses without overlapping into any other subnets.  
\_\_\_\_\_

**Step 2: Examine the addressing assignment for the Branch2 LAN2 and answer the questions below.**

1. How many IP addresses are needed for the Branch2 LAN2 subnet? \_\_\_\_\_
2. How many IP addresses are available in the currently assigned subnet? \_\_\_\_\_
3. Will the currently assigned subnet fulfill the size requirement for the Branch2 LAN2 subnet?  
\_\_\_\_\_
4. If the answer to the previous question is **no**, propose a new subnet mask that will allow for the correct number of IP addresses. \_\_\_\_\_
5. Does the subnet overlap with any of the other currently assigned networks? \_\_\_\_\_

6. If the answer to the previous question is **yes**, propose a new network address that will allow for the correct number of IP addresses without overlapping into any other subnets.  
\_\_\_\_\_

#### **Task 4: Examine the Addressing for the Links between Routers.**

##### **Step 1: Examine the addressing assignment for the link between the HQ and Branch1 routers and answer the questions below.**

1. How many IP addresses are needed for the link between the HQ and Branch1 routers? \_\_\_\_\_
2. How many IP addresses are available in the currently assigned subnet? \_\_\_\_\_
3. Will the currently assigned subnet fulfill the size requirement for the link between the HQ and Branch1 routers? \_\_\_\_\_
4. If the answer to the previous question is **no**, propose a new subnet mask that will allow for the correct number of IP addresses. \_\_\_\_\_
5. Does the subnet overlap with any of the other currently assigned networks? \_\_\_\_\_
6. If the answer to the previous question is **yes**, propose a new subnet mask that will allow for the correct number of IP addresses without overlapping into any other subnets.  
\_\_\_\_\_

##### **Step 2: Examine the addressing assignment for the link between the HQ and Branch2 routers and answer the questions below.**

1. How many IP addresses are needed for the link between the HQ and Branch2 routers? \_\_\_\_\_
2. How many IP addresses are available in the currently assigned subnet? \_\_\_\_\_
3. Will the currently assigned subnet fulfill the size requirement for the link between the HQ and Branch2 routers? \_\_\_\_\_
4. If the answer to the previous question is **no**, propose a new subnet mask that will allow for the correct number of IP addresses. \_\_\_\_\_
5. Does the subnet overlap with any of the other currently assigned networks? \_\_\_\_\_
6. If the answer to the previous question is **yes**, propose a new network address that will allow for the correct number of IP addresses without overlapping into any other subnets.  
\_\_\_\_\_

##### **Step 3: Examine the addressing assignment for the link between the Branch1 and Branch2 routers and answer the questions below.**

1. How many IP addresses are needed for the link between the Branch1 and Branch2 routers?  
\_\_\_\_\_
2. How many IP addresses are available in the currently assigned subnet? \_\_\_\_\_
3. Will the currently assigned subnet fulfill the size requirement for the link between the Branch1 and Branch2 routers? \_\_\_\_\_
4. If the answer to the previous question is **no**, propose a new subnet mask that will allow for the correct number of IP addresses. \_\_\_\_\_
5. Does the subnet overlap with any of the other currently assigned networks? \_\_\_\_\_

6. If the answer to the previous question is **yes**, propose a new subnet mask that will allow for the correct number of IP addresses without overlapping into any other subnets.
- \_\_\_\_\_

**Task 5: Document the Corrected Addressing Information.**

Record the corrected addressing information in the Addressing Table below.

Subnet	Number of IP Addresses Needed	Network Address
HQ LAN1	16,000	
HQ LAN2	8,000	
Branch1 LAN1	4,000	
Branch1 LAN2	2,000	
Branch2 LAN1	1,000	
Branch2 LAN2	500	
Link from HQ to Branch1	2	
Link from HQ to Branch2	2	
Link from Branch1 to Branch2	2	

## Activity 6.4.4: Basic Route Summarization

### Topology Diagram

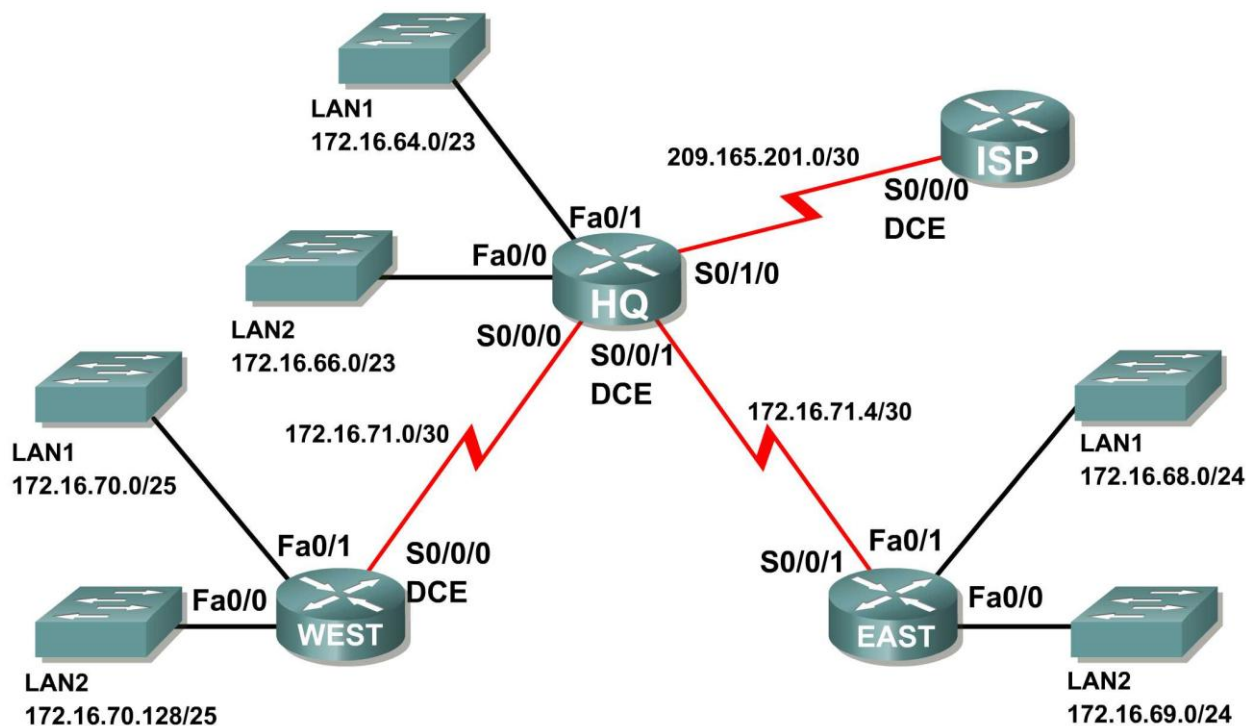

### Addressing Table

Subnet	Network Address
HQ LAN1	172.16.64.0/23
HQ LAN2	172.16.66.0/23
EAST LAN1	172.16.68.0/24
EAST LAN2	172.16.69.0/24
WEST LAN1	172.16.70.0/25
WEST LAN2	172.16.70.128/25
Link from HQ to EAST	172.16.71.4/30
Link from HQ to WEST	172.16.71.0/30
Link from HQ to ISP	209.165.201.0/30

## Learning Objectives

Upon completion of this activity, you will be able to:

- Determine summarized routes that can be used to reduce the size of routing tables.

## Scenario

In this activity, you have been given the network shown in the Topology Diagram. The subnetting and address assignments have already been completed for the network segments. Determine summarized routes that can be used to reduce the number of entries in routing tables.

### Task 1: Determine the Summary Route for the HQ LANs.

#### Step 1: List the HQ LAN1 and LAN2 in binary format.

LAN1 \_\_\_\_\_

LAN2 \_\_\_\_\_

#### Step 2: Count the number of left-most matching bits to determine the mask for the summary route.

1. How many left-most matching bits are present in the two networks? \_\_\_\_\_
2. What is the subnet mask for the summary route in decimal format? \_\_\_\_\_

#### Step 3: Copy the matching bits and then add all zeros to determine the summarized network address.

1. What are the matching bits for the two networks?  
\_\_\_\_\_
2. Add zeroes to make up the remainder of the network address in binary form.  
\_\_\_\_\_
3. What is the network address for the summary route in decimal format? \_\_\_\_\_

### Task 2: Determine the Summary Route for the EAST LANs.

#### Step 1: List the EAST LAN1 and LAN2 in binary format.

LAN1 \_\_\_\_\_

LAN2 \_\_\_\_\_

#### Step 2: Count the number of left-most matching bits to determine the mask for the summary route.

1. How many left-most matching bits are present in the two networks? \_\_\_\_\_
2. What is the subnet mask for the summary route in decimal format? \_\_\_\_\_

#### Step 3: Copy the matching bits and then add all zeros to determine the summarized network address.

1. What are the matching bits for the two networks?  
\_\_\_\_\_
2. Add zeroes to make up the remainder of the network address in binary form.  
\_\_\_\_\_

3. What is the network address for the summary route in decimal format? \_\_\_\_\_

### **Task 3: Determine the Summary Route for the WEST LANs.**

#### **Step 1: List the WEST LAN1 and LAN2 in binary format.**

LAN1 \_\_\_\_\_

LAN2 \_\_\_\_\_

#### **Step 2: Count the number of left-most matching bits to determine the mask for the summary route.**

1. How many left-most matching bits are present in the two networks? \_\_\_\_\_
2. What is the subnet mask for the summary route in decimal format? \_\_\_\_\_

#### **Step 3: Copy the matching bits and then add all zeros to determine the summarized network address.**

1. What are the matching bits for the two networks?  
\_\_\_\_\_
2. Add zeroes to make up the remainder of the network address in binary form.  
\_\_\_\_\_
3. What is the network address for the summary route in decimal format? \_\_\_\_\_

### **Task 4: Determine the Summary Route for the HQ, EAST, and WEST LANs.**

#### **Step 1: List summary networks for the HQ, EAST, and WEST LANs in binary format.**

HQ Summary Route \_\_\_\_\_

EAST Summary Route \_\_\_\_\_

WEST Summary Route \_\_\_\_\_

#### **Step 2: Count the number of left-most matching bits to determine the mask for the summary route.**

1. How many left-most matching bits are present in the three networks? \_\_\_\_\_
2. What is the subnet mask for the summary route in decimal format? \_\_\_\_\_

#### **Step 3: Copy the matching bits and then add all zeros to determine the summarized network address.**

1. What are the matching bits for the three networks?  
\_\_\_\_\_
2. Add zeroes to make up the remainder of the network address in binary form.  
\_\_\_\_\_
3. What is the network address for the summary route in decimal format? \_\_\_\_\_



## Activity 6.4.5: Challenge Route Summarization

### Topology Diagram

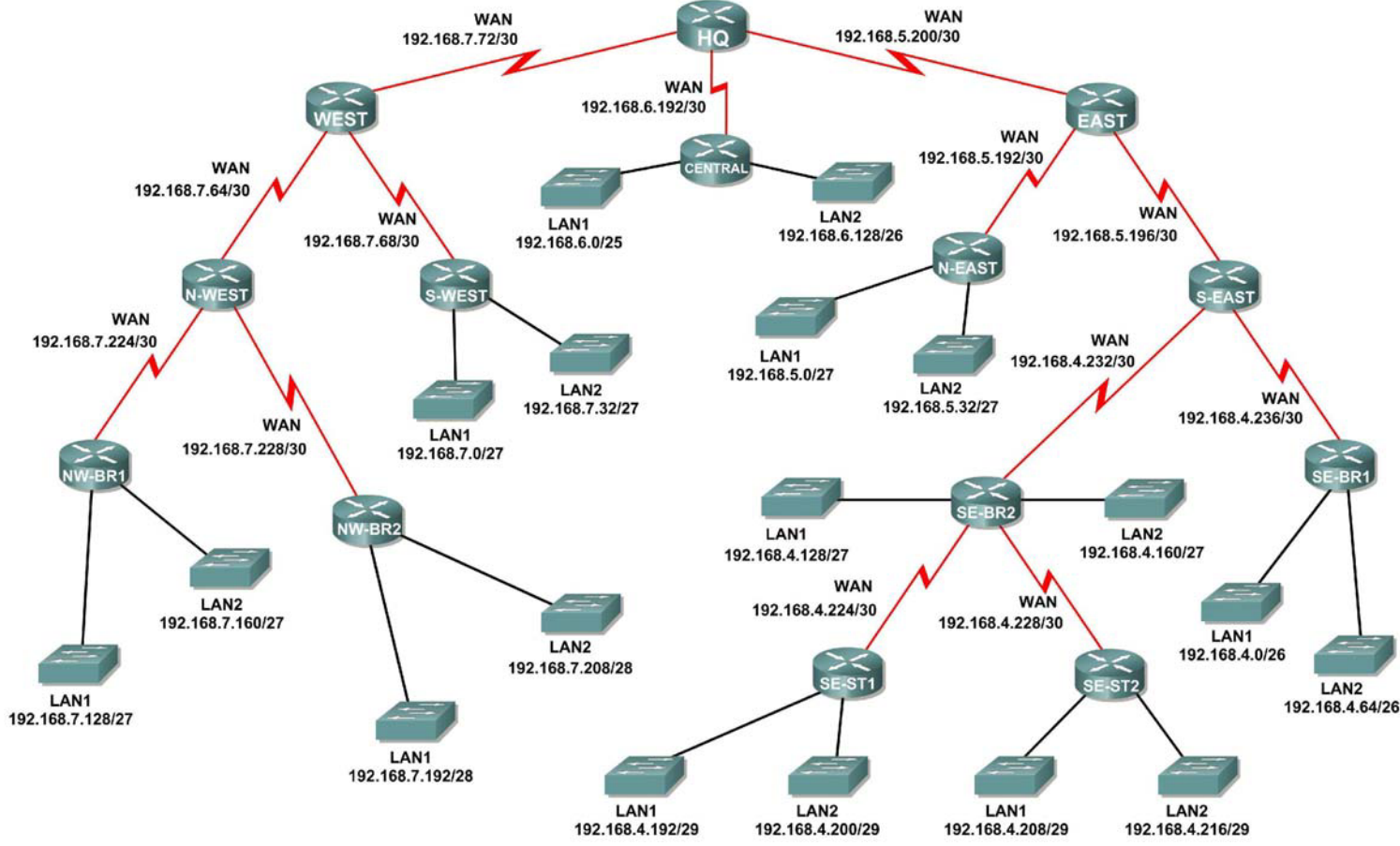

## Addressing Table

Subnet	Network Address
S-WEST LAN1	192.168.7.0/27
S-WEST LAN2	192.168.7.32/27
Link from WEST to N-WEST	192.168.7.64/30
Link from WEST to S-WEST	192.168.7.68/30
Link from HQ to WEST	192.168.7.72/30
NW-BR1 LAN1	192.168.7.128/27
NW-BR1 LAN2	192.168.7.160/27
NW-BR2 LAN1	192.168.7.192/28
NW-BR2 LAN2	192.168.7.208/28
Link from N-WEST to NW-BR1	192.168.7.224/30
Link from N-WEST to NW-BR2	192.168.7.228/30
CENTRAL LAN1	192.168.6.0/25
CENTRAL LAN2	192.168.6.128/26
Link from HQ to CENTRAL	192.168.6.192/30
N-EAST LAN1	192.168.5.0/27
N-EAST LAN2	192.168.5.32/27
Link from EAST to N-EAST	192.168.5.192/30
Link from EAST to S-EAST	192.168.5.196/30
Link from HQ to EAST	192.168.5.200/30
SE-BR1 LAN1	192.168.4.0/26
SE-BR1 LAN2	192.168.4.64/26
SE-BR2 LAN1	192.168.4.128/27
SE-BR2 LAN2	192.168.4.160/27
SE-ST1 LAN1	192.168.4.192/29
SE-ST1 LAN2	192.168.4.200/29
SE-ST2 LAN1	192.168.4.208/29
SE-ST2 LAN2	192.168.4.216/29
Link from SE-BR2 to SE-ST1	192.168.4.224/30
Link from SE-BR2 to SE-ST2	192.168.4.228/30
Link from S-EAST to SE-BR2	192.168.4.232/30
Link from S-EAST to SE-BR1	192.168.4.236/30

## Learning Objectives

Upon completion of this activity, you will be able to:

- Determine summarized routes that can be used to reduce the size of routing tables.

## Scenario

In this activity, you have been given the network shown in the Topology Diagram. The subnetting and address assignments have already been completed for the network segments. Determine summarized routes that can be used to reduce the number of entries in routing tables.

### Task 1: Determine the Summary Route for the S-WEST LANs.

**Step 1: List the S-WEST LAN1 and LAN2 in binary format.**

LAN1 \_\_\_\_\_

LAN2 \_\_\_\_\_

**Step 2: Count the number of left-most matching bits to determine the mask for the summary route.**

1. How many left-most matching bits are present in the two networks? \_\_\_\_\_
2. What is the subnet mask for the summary route in decimal format? \_\_\_\_\_

**Step 3: Copy the matching bits and then add all zeros to determine the summarized network address.**

1. What is the summary route in binary form?  
\_\_\_\_\_
2. What is the network address for the summary route in decimal format? \_\_\_\_\_

### Task 2: Determine the Summary Route for the NW-BR1 LANs.

**Step 1: List the NW-BR1 LAN1 and LAN2 in binary format.**

LAN1 \_\_\_\_\_

LAN2 \_\_\_\_\_

**Step 2: Count the number of left-most matching bits to determine the mask for the summary route.**

1. How many left-most matching bits are present in the networks? \_\_\_\_\_
2. What is the subnet mask for the summary route in decimal format? \_\_\_\_\_

**Step 3: Copy the matching bits and then add all zeros to determine the summarized network address.**

1. What is the summary route in binary form?  
\_\_\_\_\_
2. What is the network address for the summary route in decimal format? \_\_\_\_\_

### Task 3: Determine the Summary Route for the NW-BR2 LANs.

#### Step 1: List the NW-BR2 LAN1 and LAN2 in binary format.

LAN1 \_\_\_\_\_

LAN2 \_\_\_\_\_

#### Step 2: Count the number of left-most matching bits to determine the mask for the summary route.

1. How many left-most matching bits are present in the networks? \_\_\_\_\_
2. What is the subnet mask for the summary route in decimal format? \_\_\_\_\_

#### Step 3: Copy the matching bits and then add all zeros to determine the summarized network address.

1. What is the summary route in binary form?  
\_\_\_\_\_
2. What is the network address for the summary route in decimal format? \_\_\_\_\_

### Task 4: Determine the Summary Route for the Northwest Portion of the Network.

Use the networks listed below to determine a summary route for the Northwest portion of the network.

#### Step 1: List the Northwest network segments in binary format.

NW-BR1 Summary \_\_\_\_\_

NW-BR2 Summary \_\_\_\_\_

Link from N-WEST to NW-BR1 \_\_\_\_\_

Link from N-WEST to NW-BR2 \_\_\_\_\_

#### Step 2: Count the number of left-most matching bits to determine the mask for the summary route.

1. How many left-most matching bits are present in the networks? \_\_\_\_\_
2. What is the subnet mask for the summary route in decimal format? \_\_\_\_\_

#### Step 3: Copy the matching bits and then add all zeros to determine the summarized network address.

1. What is the summary route in binary form?  
\_\_\_\_\_
2. What is the network address for the summary route in decimal format? \_\_\_\_\_

### Task 5: Determine the Summary Route for the West Portion of the Network.

Use the networks listed below to determine a summary route for the West portion of the network.

#### Step 1: List the West network segments in binary format.

S-WEST Summary \_\_\_\_\_  
N-WEST Summary \_\_\_\_\_  
Link from WEST to N-WEST \_\_\_\_\_  
Link from WEST to S-WEST \_\_\_\_\_  
Link from HQ to WEST \_\_\_\_\_

#### Step 2: Count the number of left-most matching bits to determine the mask for the summary route.

1. How many left-most matching bits are present in the networks? \_\_\_\_\_
2. What is the subnet mask for the summary route in decimal format? \_\_\_\_\_

#### Step 3: Copy the matching bits and then add all zeros to determine the summarized network address.

1. What is the summary route in binary form?  
\_\_\_\_\_
2. What is the network address for the summary route in decimal format? \_\_\_\_\_

### Task 6: Determine the Summary Route for the Central Portion of the Network.

Use the networks listed below to determine a summary route for the Central portion of the network.

#### Step 1: List the Central network segments in binary format.

CENTRAL LAN1 \_\_\_\_\_  
CENTRAL LAN2 \_\_\_\_\_  
Link from HQ to CENTRAL \_\_\_\_\_

#### Step 2: Count the number of left-most matching bits to determine the mask for the summary route.

1. How many left-most matching bits are present in the networks? \_\_\_\_\_
2. What is the subnet mask for the summary route in decimal format? \_\_\_\_\_

#### Step 3: Copy the matching bits and then add all zeros to determine the summarized network address.

1. What is the summary route in binary form?  
\_\_\_\_\_
2. What is the network address for the summary route in decimal format? \_\_\_\_\_

### Task 7: Determine the Summary Route for the N-EAST LANs.

**Step 1: List the N-EAST LAN1 and LAN2 in binary format.**

LAN1 \_\_\_\_\_

LAN2 \_\_\_\_\_

**Step 2: Count the number of left-most matching bits to determine the mask for the summary route.**

1. How many left-most matching bits are present in the networks? \_\_\_\_\_
2. What is the subnet mask for the summary route in decimal format? \_\_\_\_\_

**Step 3: Copy the matching bits and then add all zeros to determine the summarized network address.**

1. What is the summary route in binary form?  
\_\_\_\_\_
2. What is the network address for the summary route in decimal format? \_\_\_\_\_

### Task 8: Determine the Summary Route for the SE-BR1 LANs.

**Step 1: List the SE-BR1 LAN1 and LAN2 in binary format.**

LAN1 \_\_\_\_\_

LAN2 \_\_\_\_\_

**Step 2: Count the number of left-most matching bits to determine the mask for the summary route.**

1. How many left-most matching bits are present in the networks? \_\_\_\_\_
2. What is the subnet mask for the summary route in decimal format? \_\_\_\_\_

**Step 3: Copy the matching bits and then add all zeros to determine the summarized network address.**

1. What is the summary route in binary form?  
\_\_\_\_\_
2. What is the network address for the summary route in decimal format? \_\_\_\_\_

### Task 9: Determine the Summary Route for the SE-BR2 LANs.

**Step 1: List the SE-BR2 LAN1 and LAN2 in binary format.**

LAN1 \_\_\_\_\_

LAN2 \_\_\_\_\_

**Step 2: Count the number of left-most matching bits to determine the mask for the summary route.**

1. How many left-most matching bits are present in the networks? \_\_\_\_\_
2. What is the subnet mask for the summary route in decimal format? \_\_\_\_\_

**Step 3: Copy the matching bits and then add all zeros to determine the summarized network address.**

1. What is the summary route in binary form?  
\_\_\_\_\_
2. What is the network address for the summary route in decimal format? \_\_\_\_\_

**Task 10: Determine the Summary Route for the SE-ST1 LANs.**

**Step 1: List the SE-ST1 LAN1 and LAN2 in binary format.**

LAN1 \_\_\_\_\_  
LAN2 \_\_\_\_\_

**Step 2: Count the number of left-most matching bits to determine the mask for the summary route.**

1. How many left-most matching bits are present in the networks? \_\_\_\_\_
2. What is the subnet mask for the summary route in decimal format? \_\_\_\_\_

**Step 3: Copy the matching bits and then add all zeros to determine the summarized network address.**

1. What is the summary route in binary form?  
\_\_\_\_\_
2. What is the network address for the summary route in decimal format? \_\_\_\_\_

**Task 11: Determine the Summary Route for the SE-ST2 LANs.**

**Step 1: List the SE-ST2 LAN1 and LAN2 in binary format.**

LAN1 \_\_\_\_\_  
LAN2 \_\_\_\_\_

**Step 2: Count the number of left-most matching bits to determine the mask for the summary route.**

1. How many left-most matching bits are present in the networks? \_\_\_\_\_
2. What is the subnet mask for the summary route in decimal format? \_\_\_\_\_

**Step 3: Copy the matching bits and then add all zeros to determine the summarized network address.**

1. What is the summary route in binary form?  
\_\_\_\_\_
2. What is the network address for the summary route in decimal format? \_\_\_\_\_

**Task 12: Determine the Summary Route for the Southeast Portion of the Network.**

Use the networks listed below to determine a summary route for the Southeast portion of the network.

**Step 1: List the Southeast network segments in binary format.**

SE-BR1 Summary \_\_\_\_\_  
SE-BR2 Summary \_\_\_\_\_  
SE-ST1 Summary \_\_\_\_\_  
SE-ST2 Summary \_\_\_\_\_  
Link from SE-BR2 to SE-ST1 \_\_\_\_\_  
Link from SE-BR2 to SE-ST2 \_\_\_\_\_  
Link from S-EAST to SE-BR1 \_\_\_\_\_  
Link from S-EAST to SE-BR2 \_\_\_\_\_

**Step 2: Count the number of left-most matching bits to determine the mask for the summary route.**

1. How many left-most matching bits are present in the networks? \_\_\_\_\_
2. What is the subnet mask for the summary route in decimal format? \_\_\_\_\_

**Step 3: Copy the matching bits and then add all zeros to determine the summarized network address.**

1. What is the summary route in binary form?  
\_\_\_\_\_
2. What is the network address for the summary route in decimal format? \_\_\_\_\_

**Task 13: Determine the Summary Route for the East Portion of the Network.**

Use the networks listed below to determine a summary route for the East portion of the network.

**Step 1: List the East network segments in binary format.**

S-EAST Summary \_\_\_\_\_  
N-EAST Summary \_\_\_\_\_  
Link from EAST to N-EAST \_\_\_\_\_  
Link from EAST to S-EAST \_\_\_\_\_  
Link from HQ to EAST \_\_\_\_\_

**Step 2: Count the number of left-most matching bits to determine the mask for the summary route.**

1. How many left-most matching bits are present in the networks? \_\_\_\_\_
2. What is the subnet mask for the summary route in decimal format? \_\_\_\_\_



**Step 3: Copy the matching bits and then add all zeros to determine the summarized network address.**

1. What is the summary route in binary form?  
\_\_\_\_\_
2. What is the network address for the summary route in decimal format? \_\_\_\_\_

**Task 14: Determine the Summary Route for the Entire Network.**

Use the networks listed below to determine a summary route for the entire network.

**Step 1: List the East, West, and Central summary routes in binary format.**

EAST Summary \_\_\_\_\_  
WEST Summary \_\_\_\_\_  
CENTRAL Summary \_\_\_\_\_

**Step 2: Count the number of left-most matching bits to determine the mask for the summary route.**

1. How many left-most matching bits are present in the networks? \_\_\_\_\_
2. What is the subnet mask for the summary route in decimal format? \_\_\_\_\_

**Step 3: Copy the matching bits and then add all zeros to determine the summarized network address.**

1. What is the summary route in binary form?  
\_\_\_\_\_
2. What is the network address for the summary route in decimal format? \_\_\_\_\_

## Activity 6.4.6: Troubleshooting Route Summarization

### Topology Diagram

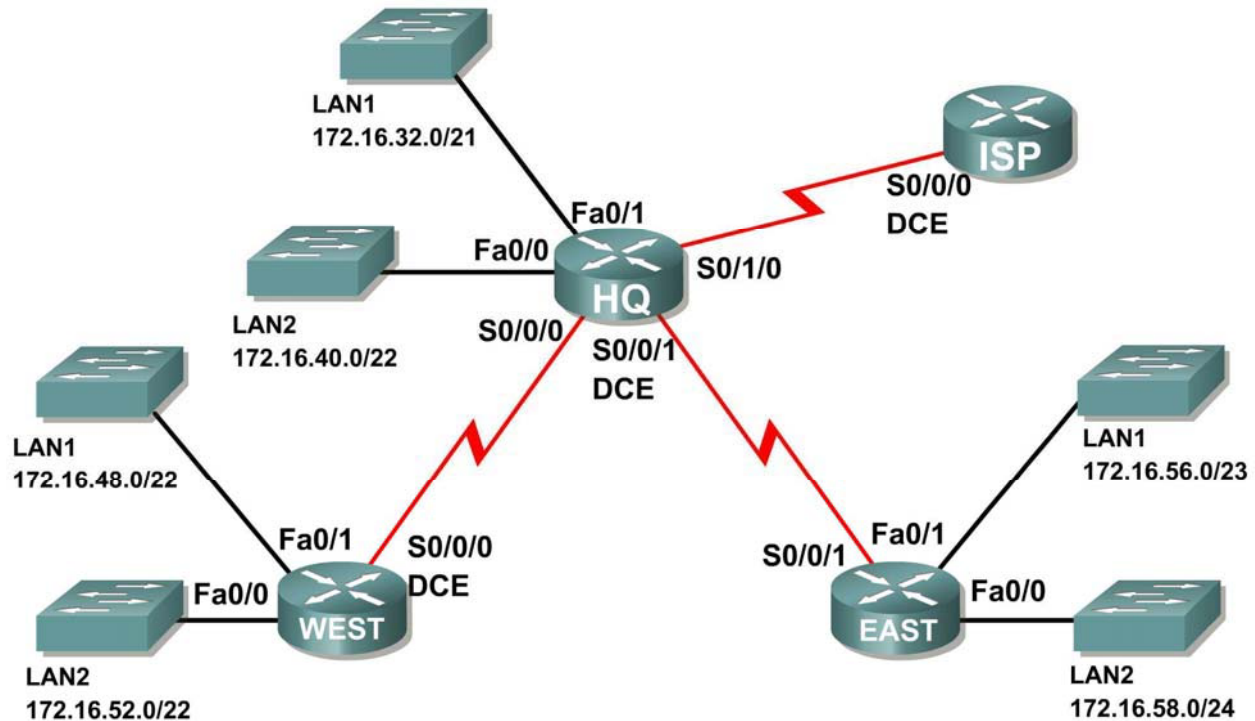

Addressing Table

Router	Summary Route	Network Address
HQ	WEST LANs	172.16.52.0/21
HQ	EAST LANs	172.16.56.0/23
WEST	HQ LANs	172.16.32.0/19
WEST	EAST LANs	172.16.58.0/23
EAST	HQ LANs	172.16.30.0/20
EAST	WEST LANs	172.16.48.0/21
ISP	HQ, WEST, and EAST LANs	172.16.32.0/18

### Learning Objectives

Upon completion of this activity, you will be able to:

- Discover errors in route summarization.
- Propose solutions for summarized routes.
- Document the corrected summarized routes.

## Scenario

In this activity, the LAN IP addressing has already been completed for the network shown in the Topology Diagram. VLSM has been used to subnet the address space. The summary routes that are shown in the Addressing Table below the Topology Diagram are incorrect. You will need to troubleshoot the summary routes that have been assigned to determine where errors are present and determine the correct summary routes where needed.

### Task 1: Examine the Summary Routes on the HQ Router.

Examine the summary routes on the HQ router and answer the questions below.

1. What is the summary route for the WEST LANs? \_\_\_\_\_
2. Is this summary route correct? \_\_\_\_\_
3. If the route is not correct, what is the correct summary route for the WEST LANs?  
\_\_\_\_\_
4. What is the summary route for the EAST LANs? \_\_\_\_\_
5. Is this summary route correct? \_\_\_\_\_
6. If the route is not correct, what is the correct summary route for the EAST LANs?  
\_\_\_\_\_

### Task 2: Examine the Summary Routes on the WEST Router.

Examine the summary routes on the WEST router and answer the questions below.

1. What is the summary route for the HQ LANs? \_\_\_\_\_
2. Is this summary route correct? \_\_\_\_\_
3. If the route is not correct, what is the correct summary route for the HQ LANs?  
\_\_\_\_\_
4. What is the summary route for the EAST LANs? \_\_\_\_\_
5. Is this summary route correct? \_\_\_\_\_
6. If the route is not correct, what is the correct summary route for the EAST LANs?  
\_\_\_\_\_

**Task 3: Examine the Summary Routes on the EAST Router.**

Examine the summary routes on the EAST router and answer the questions below.

1. What is the summary route for the WEST LANs? \_\_\_\_\_
2. Is this summary route correct? \_\_\_\_\_
3. If the route is not correct, what is the correct summary route for the WEST LANs?  
\_\_\_\_\_
4. What is the summary route for the HQ LANs? \_\_\_\_\_
5. Is this summary route correct? \_\_\_\_\_
6. If the route is not correct, what is the correct summary route for the HQ LANs?  
\_\_\_\_\_

**Task 4: Examine the Summary Route on the ISP Router.**

Examine the summary route on the ISP router and answer the questions below.

1. What is the summary route for the HQ, WEST, and EAST LANs?  
\_\_\_\_\_
2. Is this summary route correct? \_\_\_\_\_
3. If the route is not correct, what is the correct summary route for the HQ, WEST, and EAST LANs?  
\_\_\_\_\_

**Task 5: Document the Corrected Summary Routes.**

Record the corrected summary routes in the Addressing Table below.

Router	Summary Route	Network Address
HQ	WEST LANs	
HQ	EAST LANs	
WEST	HQ LANs	
WEST	EAST LANs	
EAST	HQ LANs	
EAST	WEST LANs	
ISP	HQ, WEST, and EAST LANs	