

# ELECTRIC ORANGE

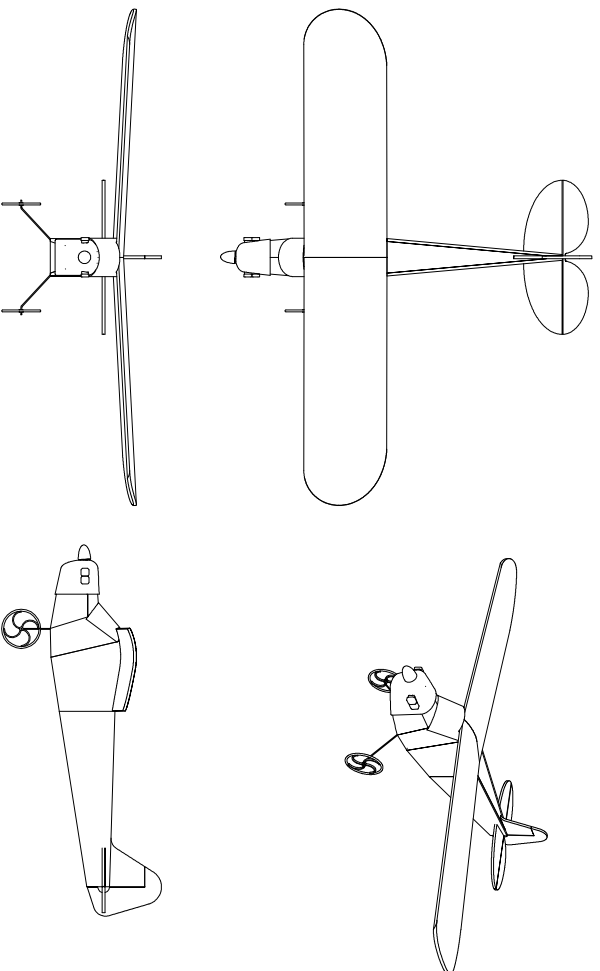

## J3 Cub Trainer



### SPECIFICATION

|               |  |
|---------------|--|
| Wing Span:    | 960mm (38.4")  |
| Length:       | 690mm (27.6")  |
| Power System: | GWS EPS-350C-C or D                                  |
| Propeller:    | 10x8 or 9x7 Slow Flyer                               |
| Weight:       | 400 - 450g (14 - 16oz)                               |
| Wing Loading: | 27.8 - 31.3 g/dm <sup>2</sup><br>(9 - 10.3 oz/sq ft) |
| Control:      | 3 Channel  |
| Material:     | XPS-Lite, Depron or FFF<br>(6mm Nominal Thickness)   |



UNDERCARRIAGE WIRE  
 MATERIAL: 2.5MM PLANO WIRE  
 1 REQUIRED

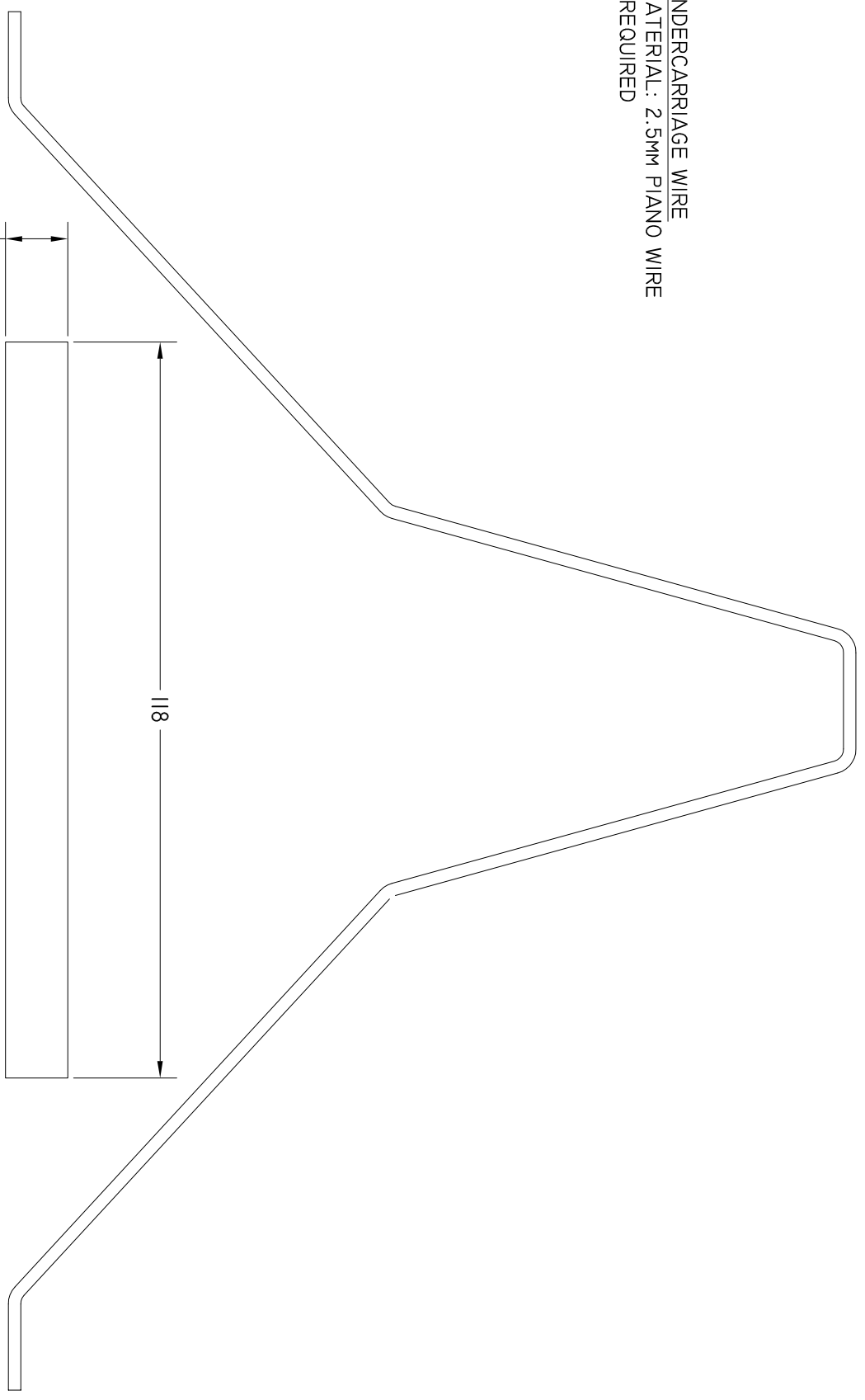

MOTOR STICK  
 MATERIAL: 10 X 10 SQUARE PINE OR SPRUCE  
 1 REQUIRED

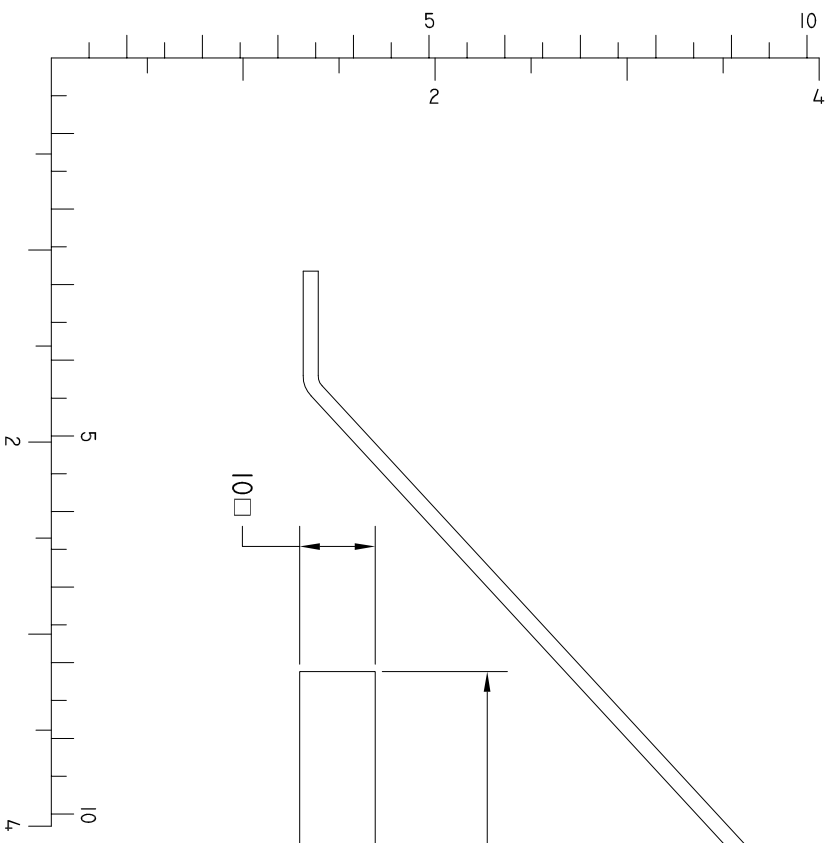

**J3 CUB "PARK TRAINER"**  
 REVISION 4.0 DECEMBER 2004  
 COPYRIGHT © 2005 ELECTRIC ORANGE  
 ALL RIGHTS RESERVED

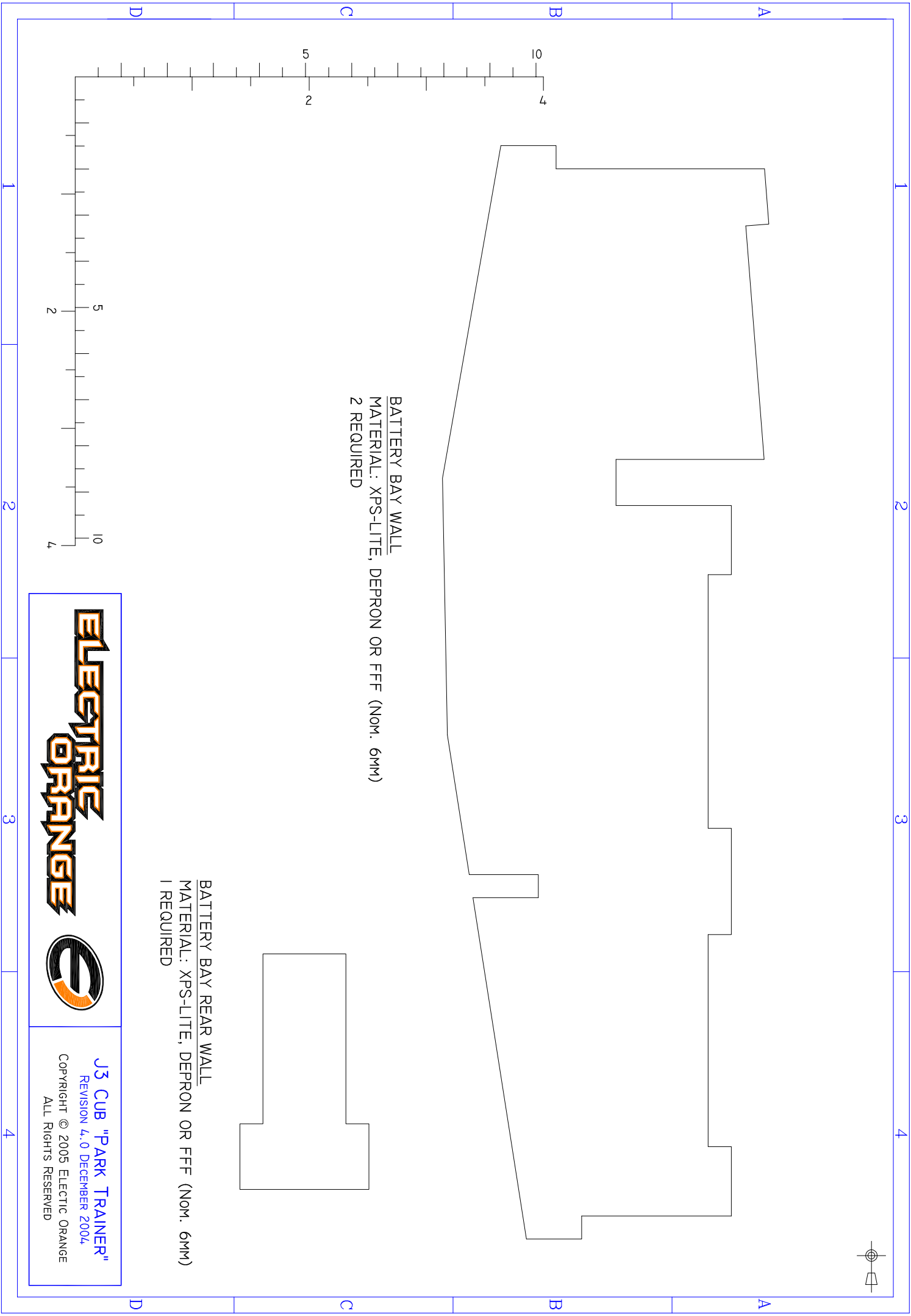

**BATTERY BAY WALL**  
 MATERIAL: XPS-LITE, DEPRON OR FFF (Nom. 6mm)  
 2 REQUIRED

**BATTERY BAY REAR WALL**  
 MATERIAL: XPS-LITE, DEPRON OR FFF (Nom. 6mm)  
 1 REQUIRED



**J3 CUB "PARK TRAINER"**  
 REVISION 4.0 DECEMBER 2004  
 COPYRIGHT © 2005 ELECTRIC ORANGE  
 ALL RIGHTS RESERVED



RC TRAY  
 MATERIAL: XPS-LITE, DEPRON OR FFF (NOM. 6MM)  
 1 REQUIRED

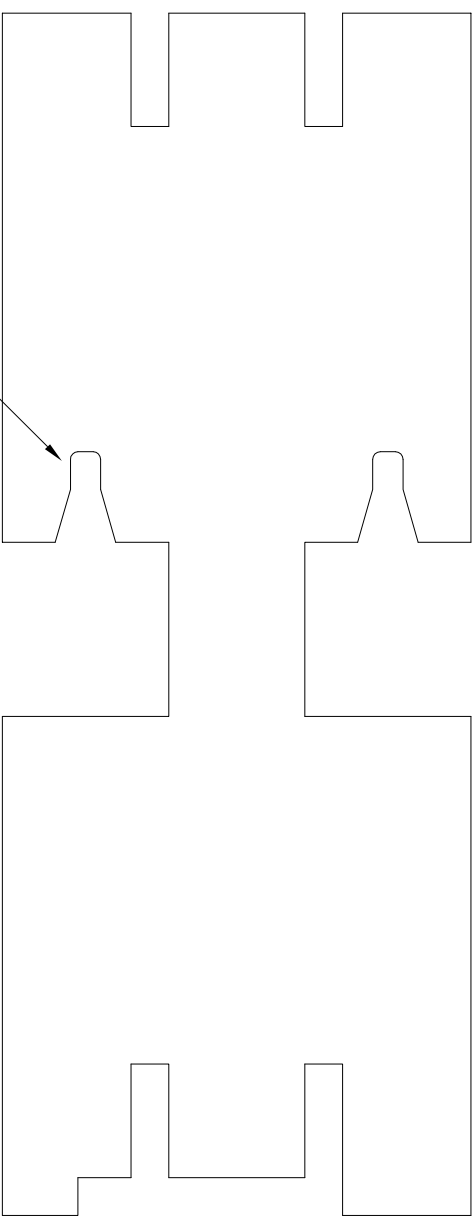

CUT OUT FOR SERVO WIRE

23 OR TO SUIT SERVO

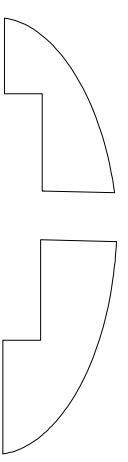

TURTLE DECK FORMERS  
 MATERIAL: XPS-LITE, DEPRON OR FFF (NOM. 6MM)  
 1 EACH REQUIRED

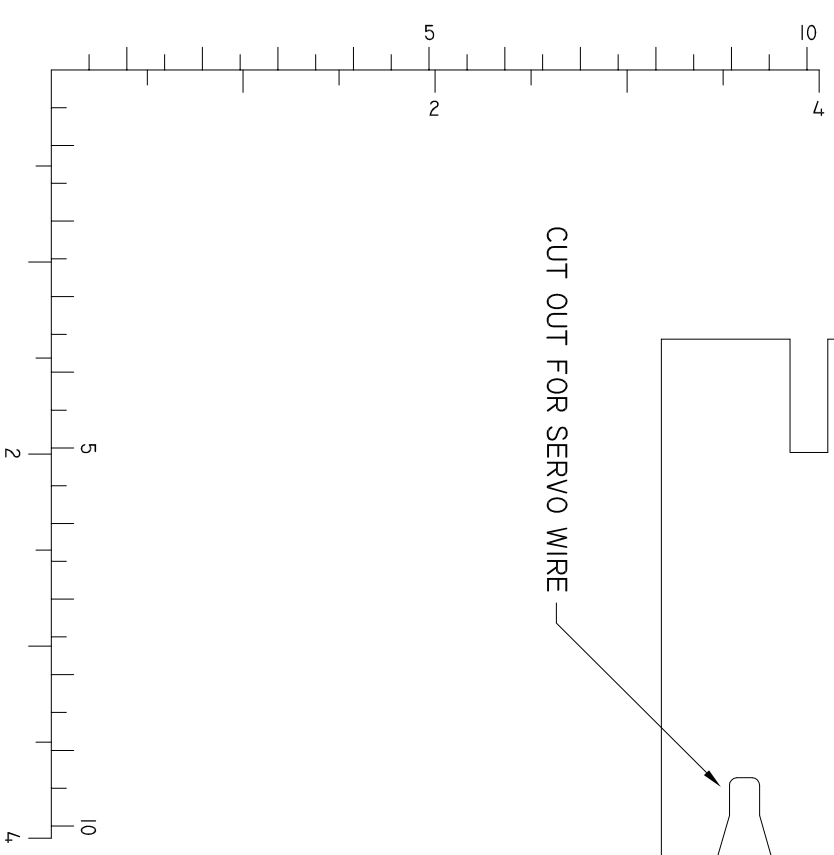

**J3 CUB "PARK TRAINER"**  
 REVISION 4.0 DECEMBER 2004.  
 COPYRIGHT © 2005 ELECTRIC ORANGE  
 ALL RIGHTS RESERVED

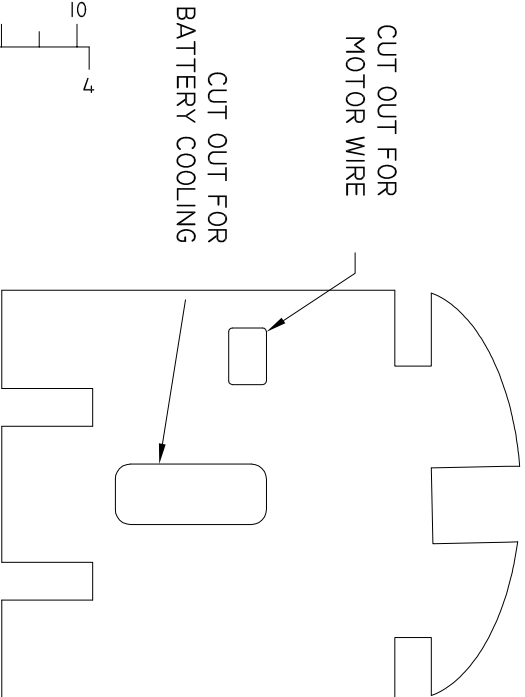

CUT OUT FOR  
MOTOR WIRE

CUT OUT FOR  
BATTERY COOLING

FIRE WALL

MATERIAL: XPS-LITE, DEPRON OR FFF (Nom. 6mm)  
1 REQUIRED

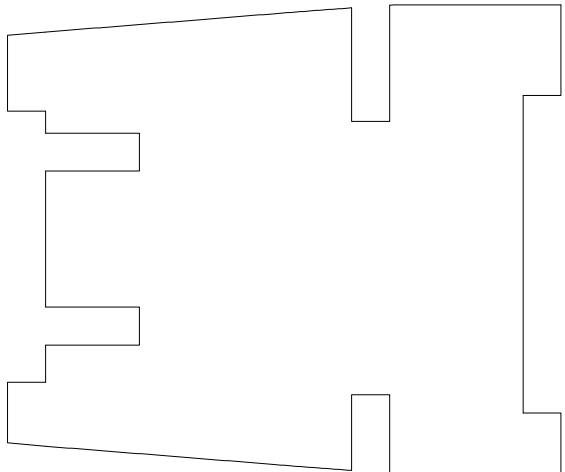

MOTOR STICK SHELL

MATERIAL: XPS-LITE, DEPRON OR FFF (Nom. 6mm)  
1 REQUIRED

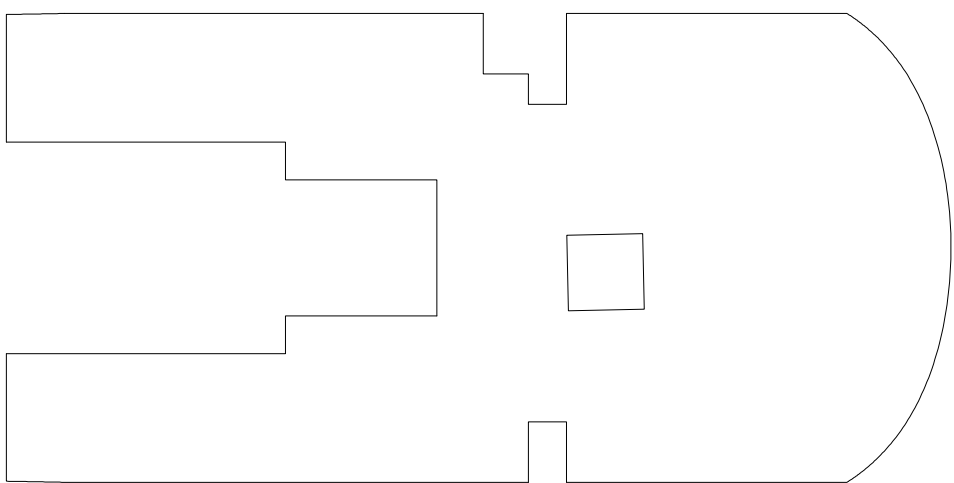

FORMER #1

MATERIAL: XPS-LITE, DEPRON OR FFF (Nom. 6mm)  
1 REQUIRED

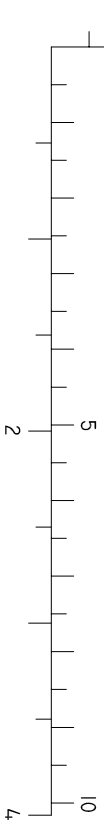

**J3 CUB "PARK TRAINER"**  
REVISION 4.0 DECEMBER 2004  
COPYRIGHT © 2005 ELECTRIC ORANGE  
ALL RIGHTS RESERVED



FORMER #2  
 MATERIAL: XPS-LITE, DEPRON OR FFF (Nom. 6mm)  
 1 REQUIRED

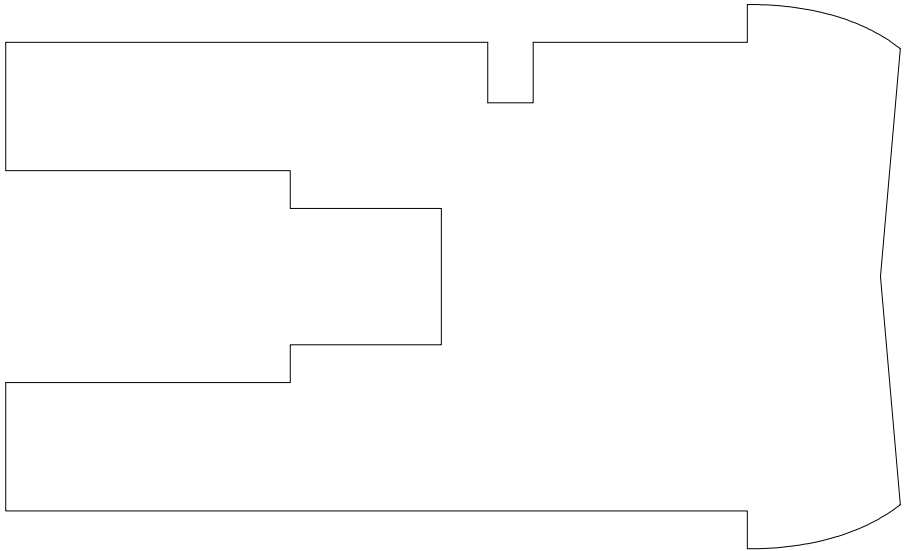

FORMER #3  
 MATERIAL: XPS-LITE, DEPRON OR FFF (Nom. 6mm)  
 1 REQUIRED

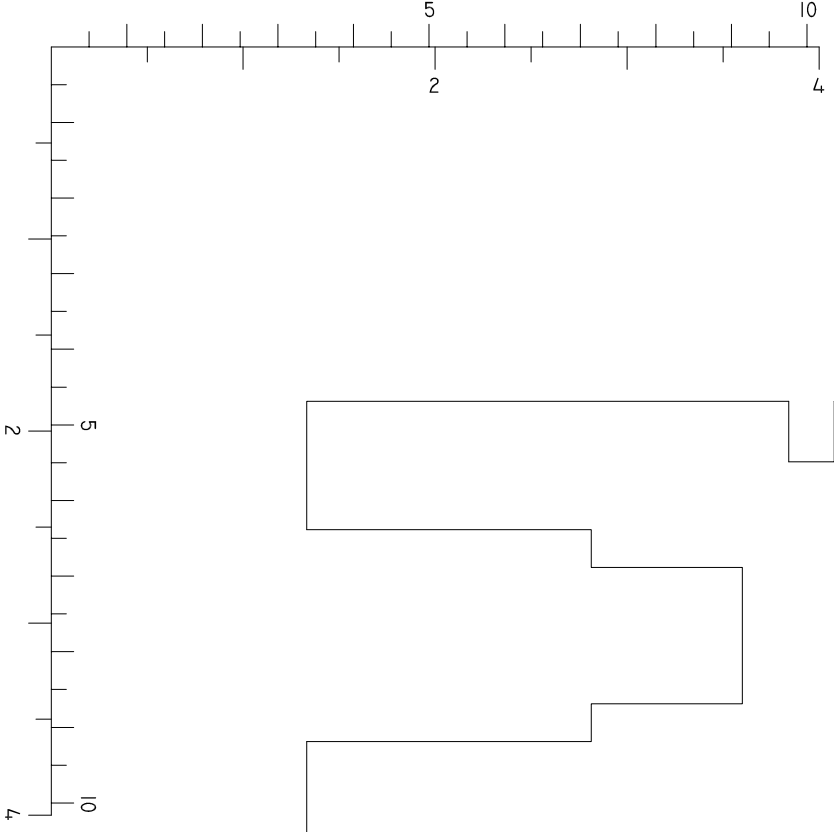
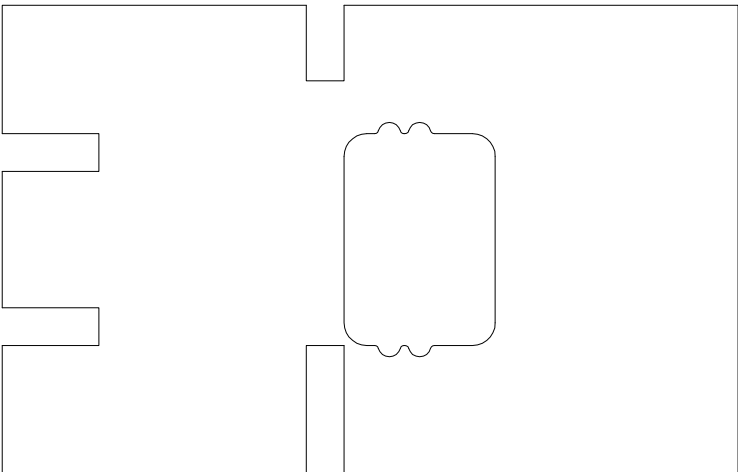

**J3 CUB "PARK TRAINER"**  
 REVISION 4.0 DECEMBER 2004.  
 COPYRIGHT © 2005 ELECTRIC ORANGE  
 ALL RIGHTS RESERVED

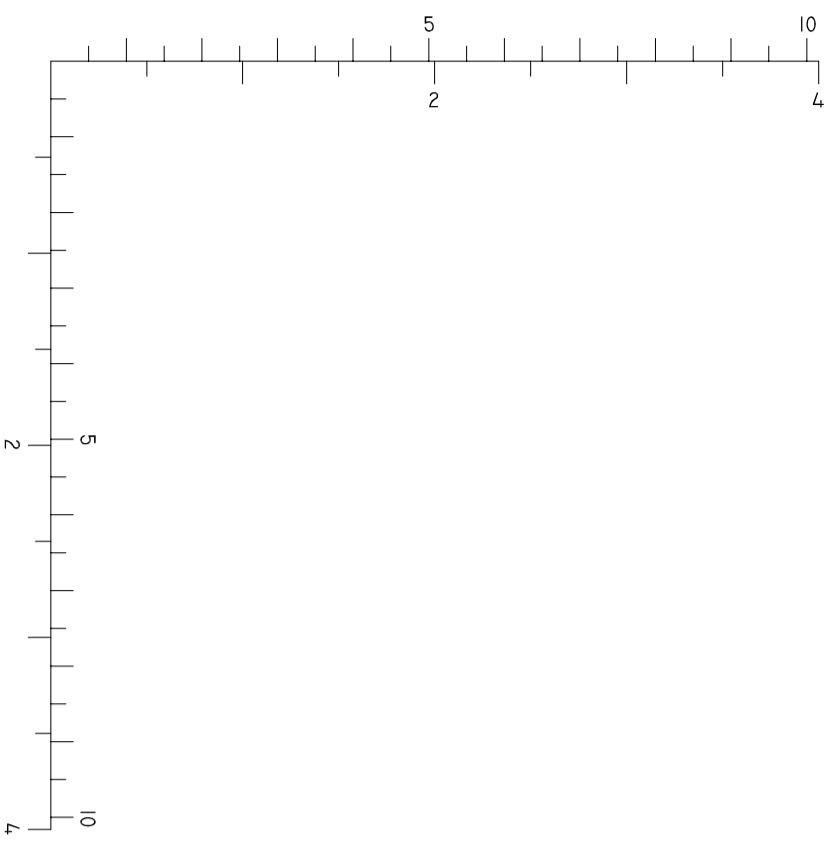

NOTE: IF USING XPS-LITE OR DEPRON, GROOVE ALONG LINES AND PLACE PACKING TAPE ON THE OUTSIDE SURFACE  
 GROOVES 3MM DEEP BY 1MM WIDE  
 FOR FFF, WORK ALONG CURVE TO SOFTEN THE MATERIAL TO ALLOW FORMING

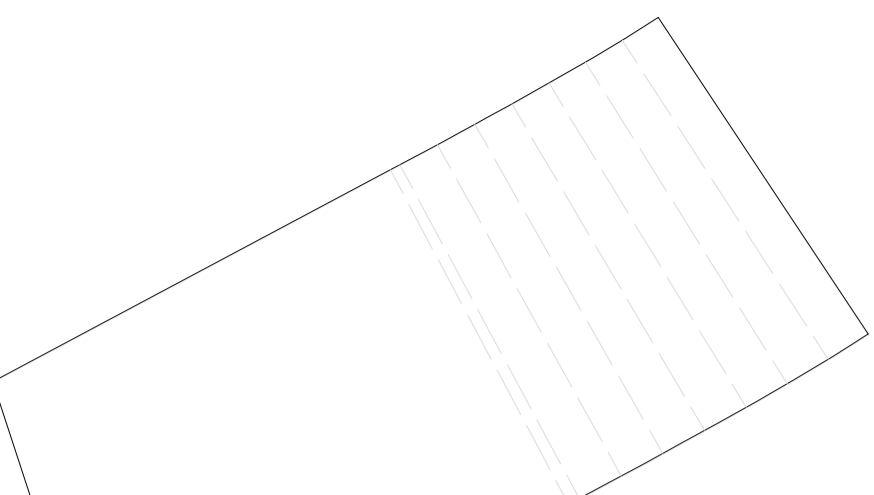

FUSELAGE SIDE  
 MATERIAL: XPS-LITE, DEPRON OR FFF (Nom. 6MM)  
 2 REQUIRED

VERTICAL STABILISER  
 MATERIAL: XPS-LITE, DEPRON OR FFF (Nom. 6MM)  
 1 REQUIRED

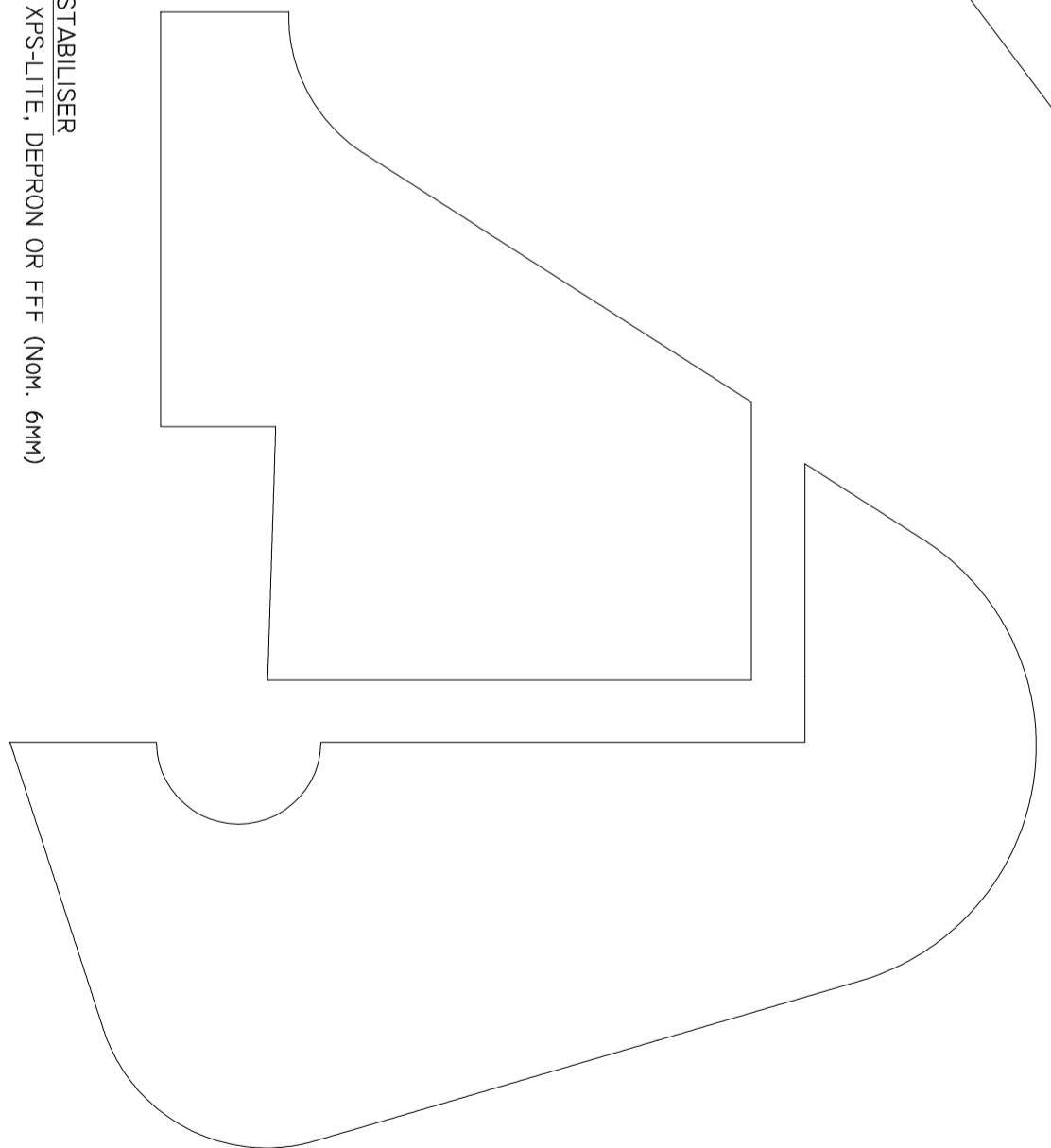

RUDDER  
 MATERIAL: XPS-LITE, DEPRON OR FFF (Nom. 6MM)  
 1 REQUIRED

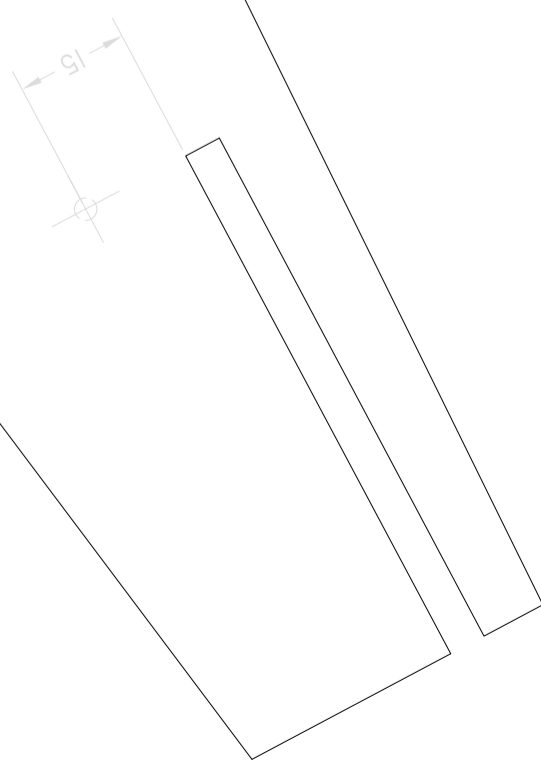

J3 CUB "PARK TRAINER"  
 REVISION 4, 0 DECEMBER 2004  
 COPYRIGHT © 2005 ELECTRIC ORANGE  
 ALL RIGHTS RESERVED

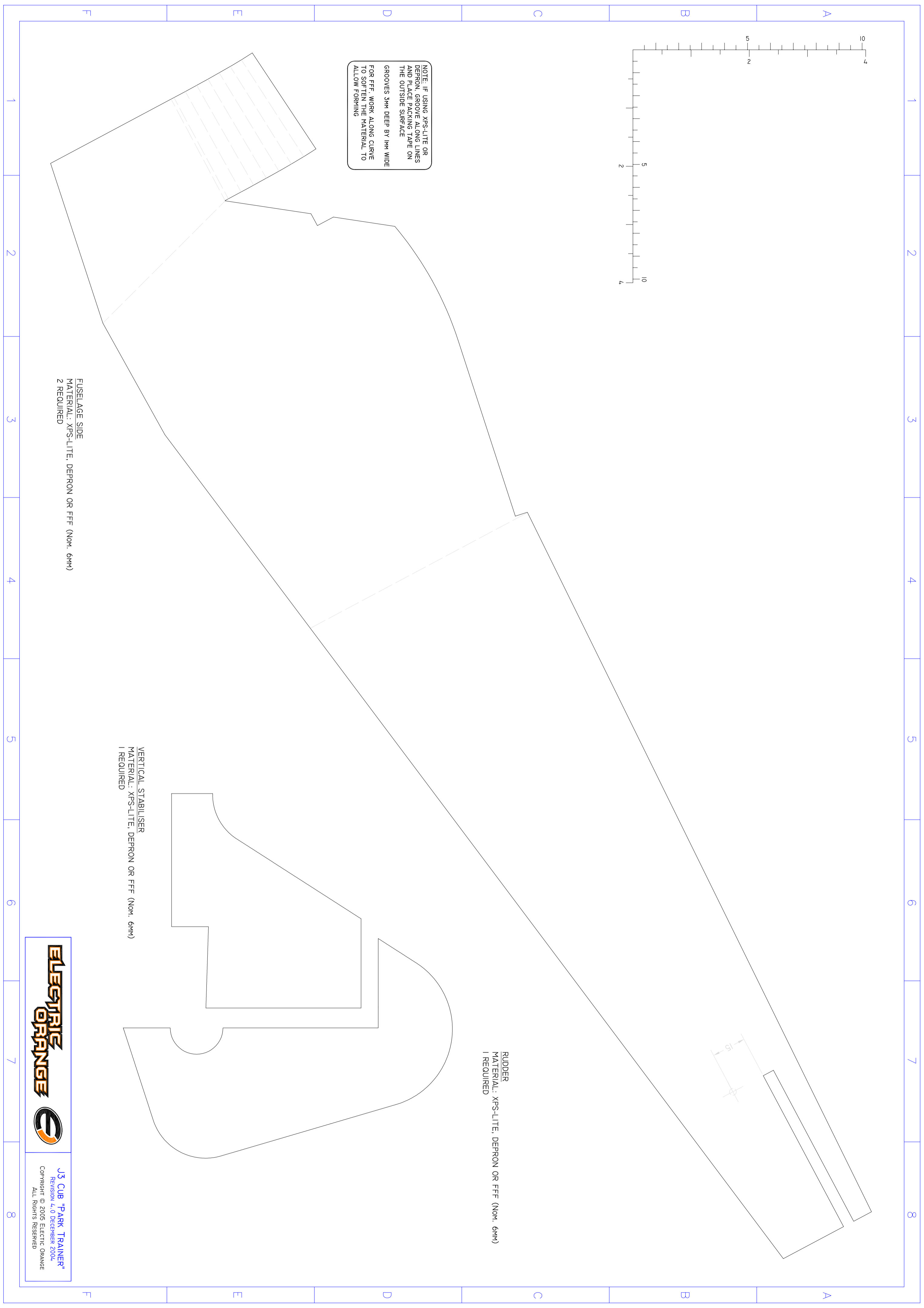

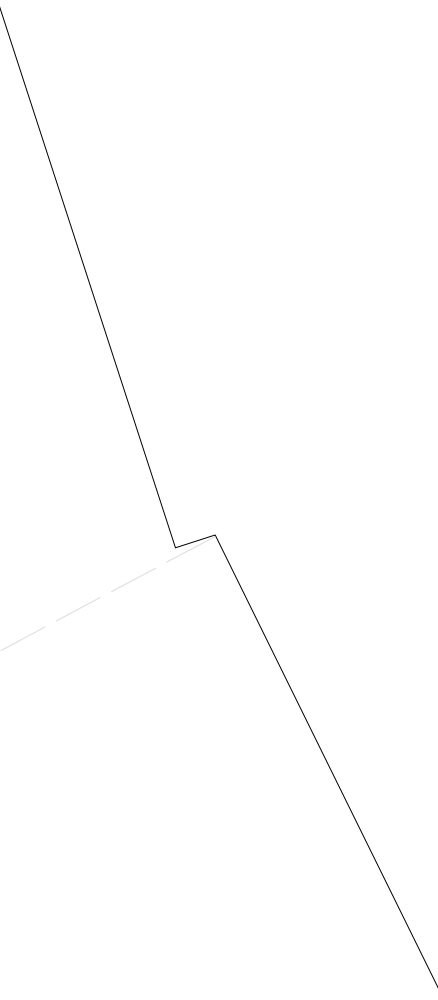
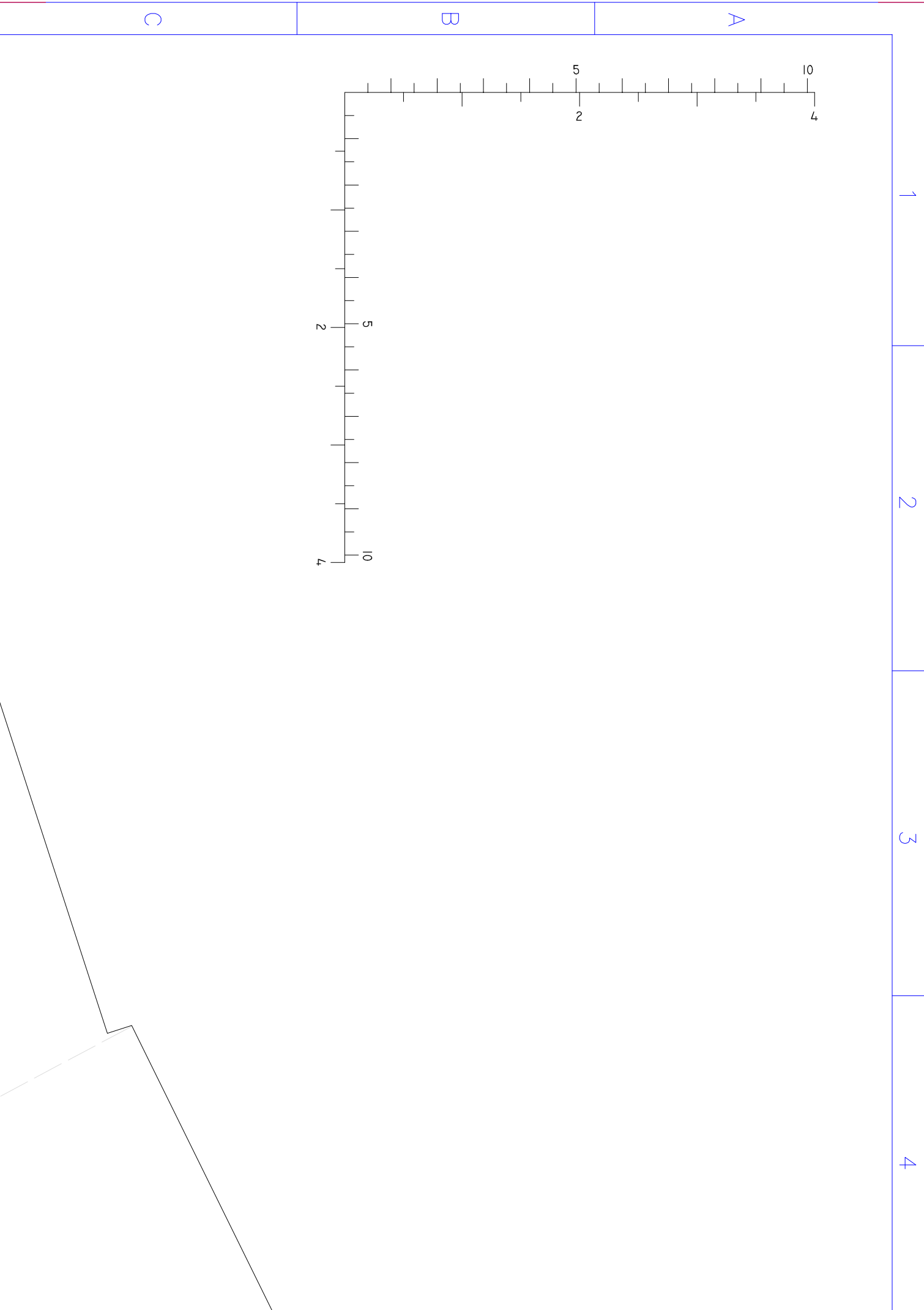



5

6

7

8

A

B

C

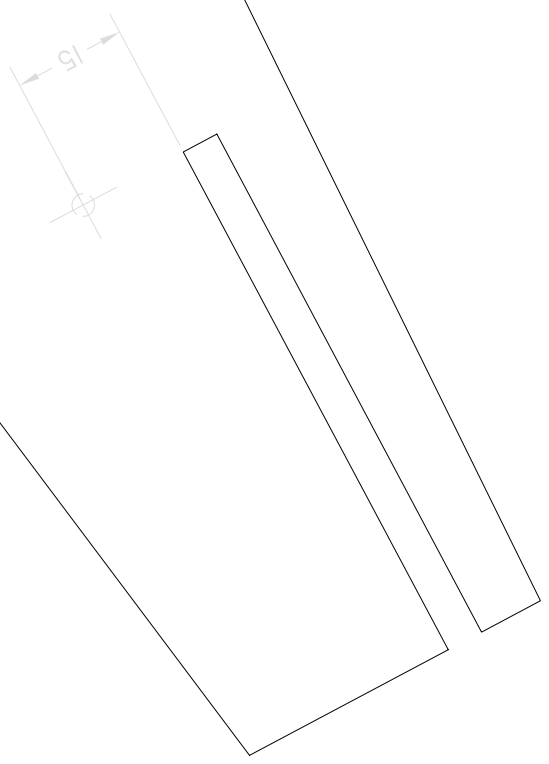

**RUDDER**  
MATERIAL: XPS-LITE, DEPRON OR FFF (Nom. 6mm)  
I REQUIRED

NOTE: IF USING XPS-LITE OR DEPRON, GROOVE ALONG LINES AND PLACE PACKING TAPE ON THE OUTSIDE SURFACE  
GROOVES 3MM DEEP BY 1MM WIDE  
FOR FFF, WORK ALONG CURVE TO SOFTEN THE MATERIAL TO ALLOW FORMING

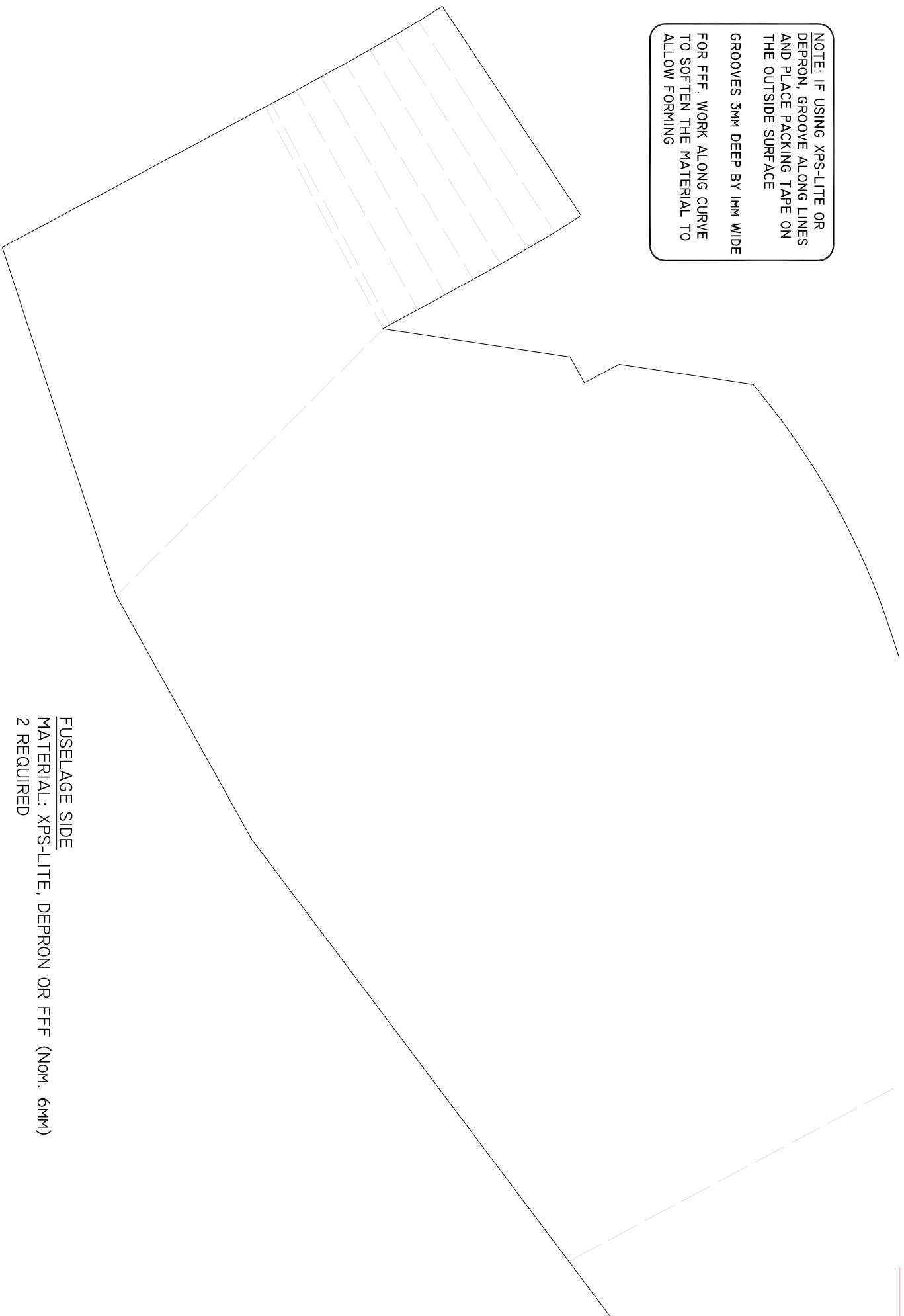

FUSELAGE SIDE  
MATERIAL: XPS-LITE, DEPRON OR FFF (Nom. 6MM)  
2 REQUIRED

1 2 3 4

F

E

D

VERTICAL STABILISER  
MATERIAL: XPS-LITE, DEPRON OR FFF (Nom. 6mm)  
1 REQUIRED

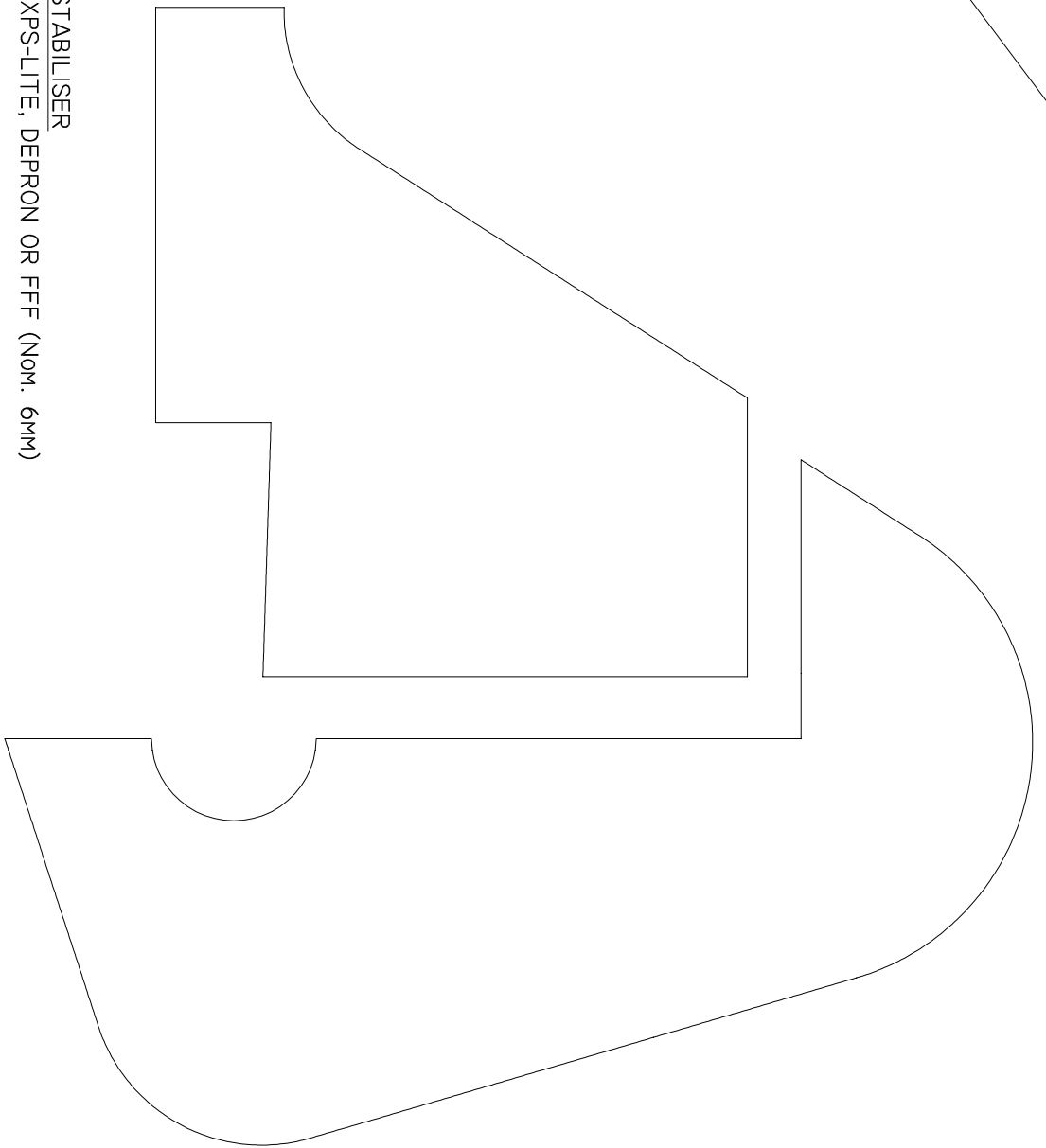

5

6

7

8

F

E

D

**ELECTRIC ORANGE**



**J3 CUB "PARK TRAINER"**  
REVISION 4, 0 DECEMBER 2004.  
COPYRIGHT © 2005 ELECTIC ORANGE  
ALL RIGHTS RESERVED

1 2 3 4 5 6 7 8

200

4

4

162

WING PANEL  
MATERIAL: XPS-LITE, DEPRON OR FFF (Nom. 6mm)  
2 REQUIRED

CORD 160

WING FORMING TEMPLATE - HEAT FORM

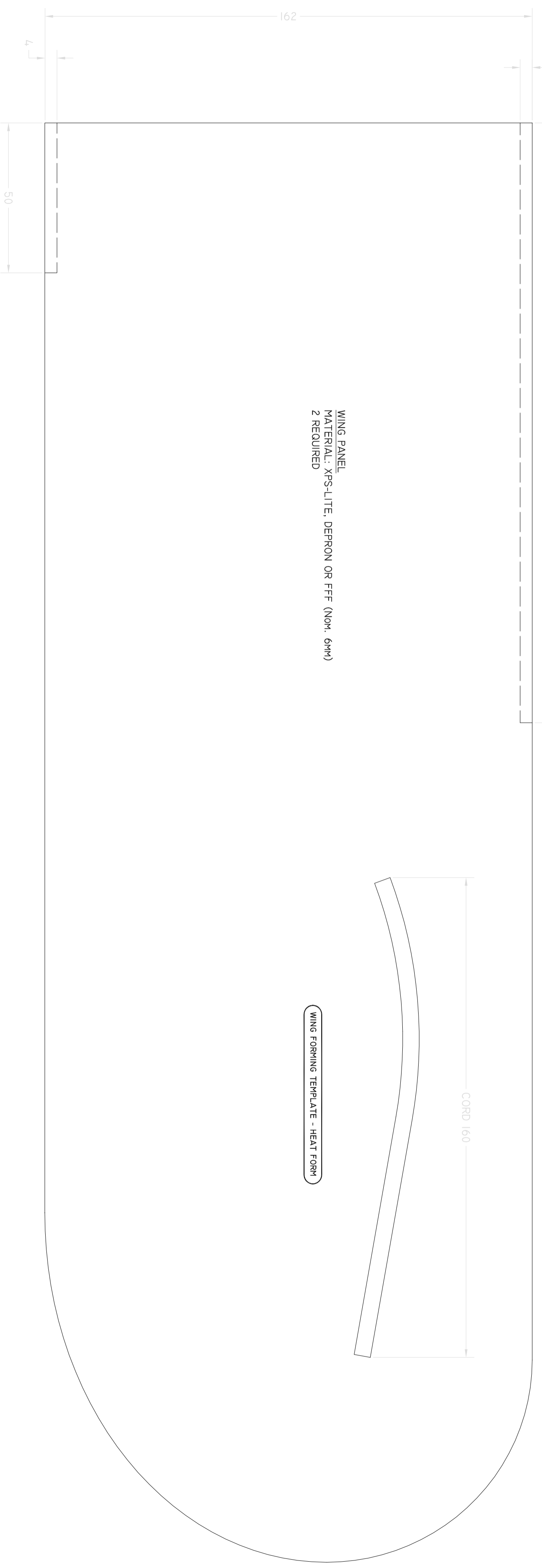

ELEVATOR  
MATERIAL: XPS-LITE, DEPRON OR FFF (Nom. 6mm)  
1 REQUIRED

HORIZONTAL STABILISER  
MATERIAL: XPS-LITE, DEPRON OR FFF (Nom. 6mm)  
1 REQUIRED

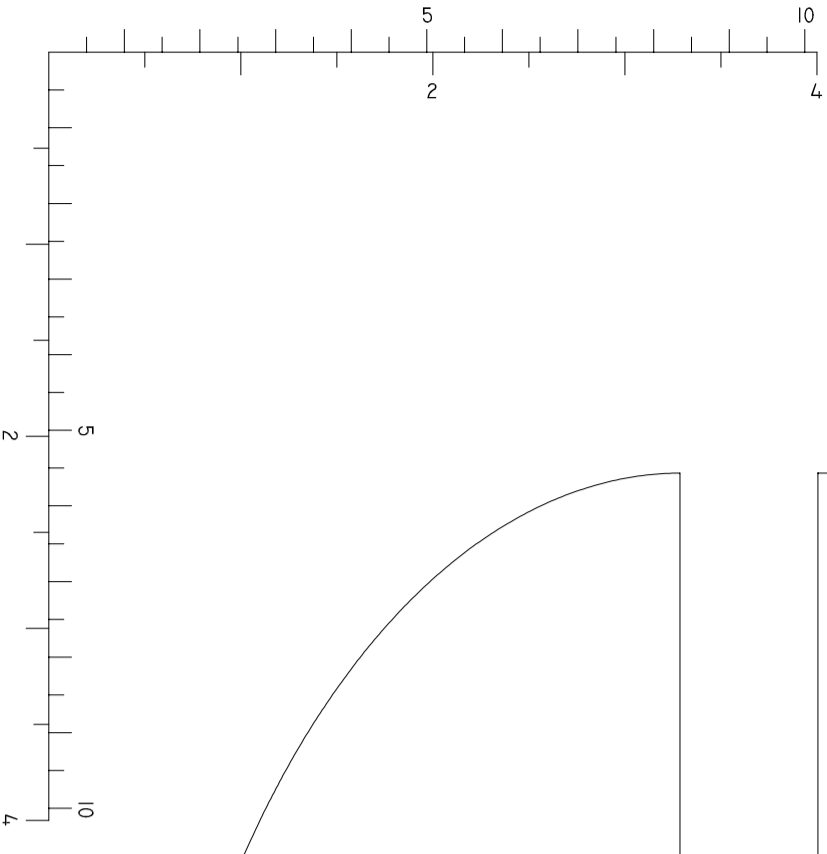

J3 CUB "PARK TRAINER"  
REVISION 4, 0 DECEMBER 2004  
COPYRIGHT © 2005 ELECTRIC ORANGE  
ALL RIGHTS RESERVED

F E D C B A

1 2 3 4 5 6 7 8

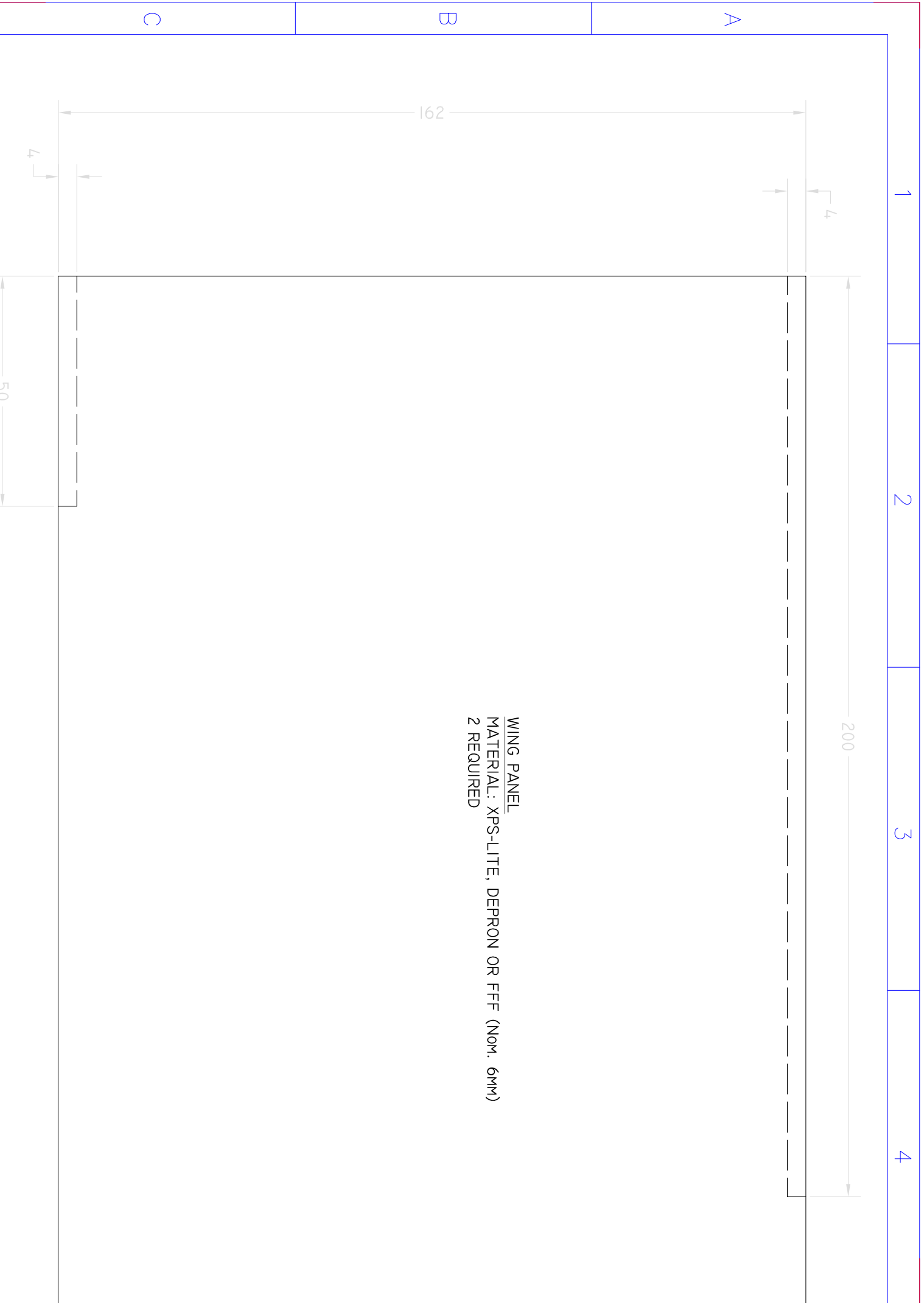

WING PANEL  
MATERIAL: XPS-LITE, DEPRON OR FFF (Nom. 6mm)  
2 REQUIRED

5

6

7

8

CORD 160

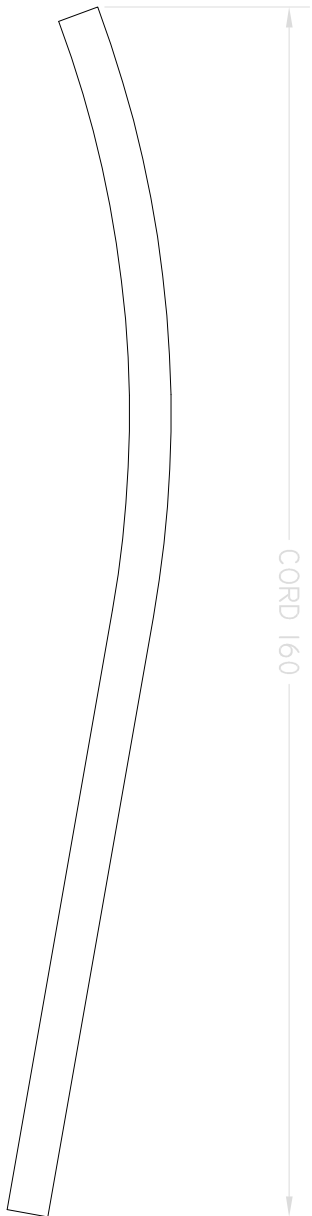

WING FORMING TEMPLATE - HEAT FORM

A

B

C

F

E

D

5

10

2

4

1

2

5

2

4

10

3

4

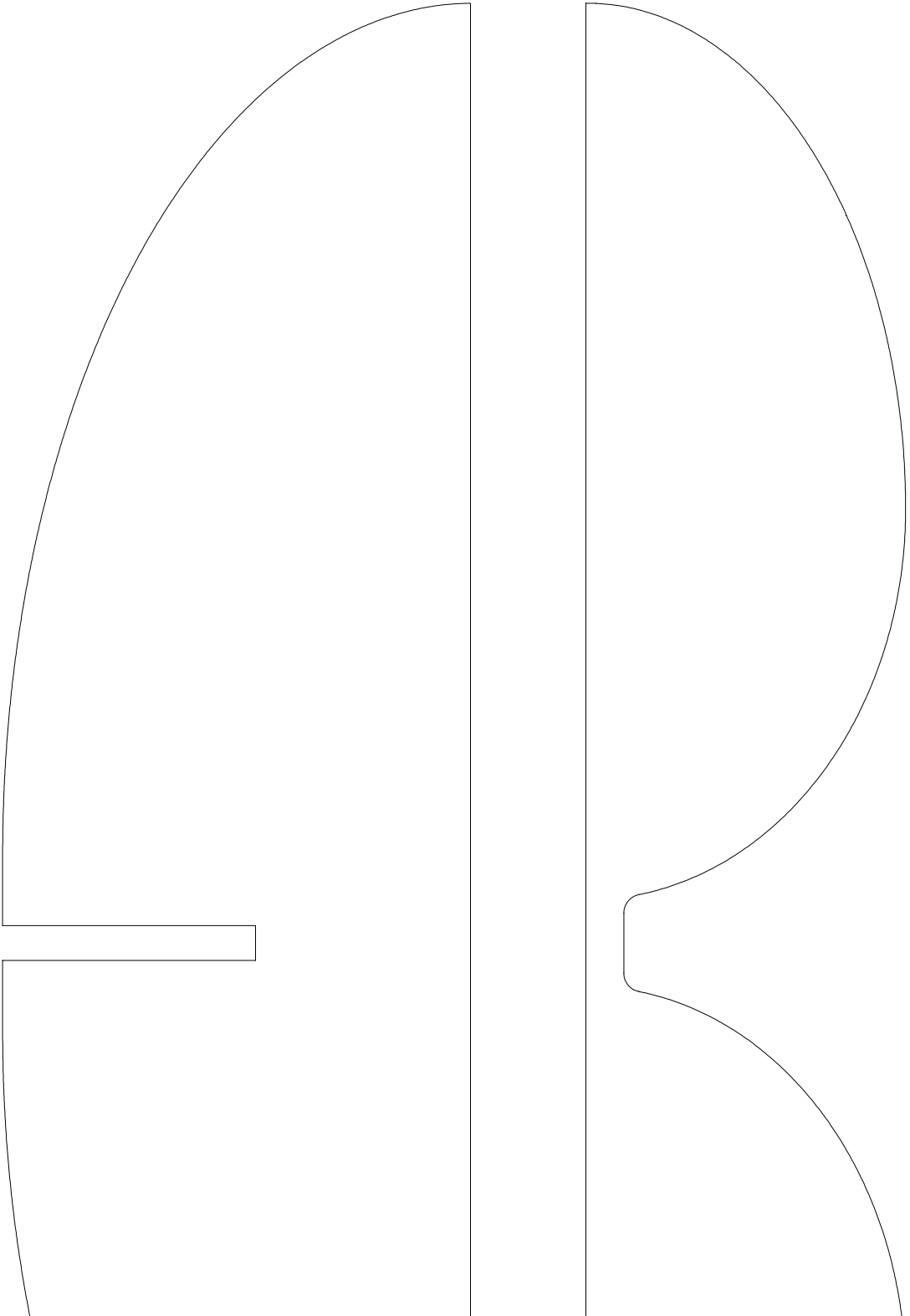

ELEVATOR  
MATERIAL: XPS-LITE, DEPRON OR FFF (Nom. 6mm)  
I REQUIRED

HORIZONTAL STABILISER  
MATERIAL: XPS-LITE, DEPRON OR FFF (Nom. 6mm)  
I REQUIRED

**ELECTRIC  
ORANGE**



**J3 CUB "PARK TRAINER"**  
REVISION 4, 0 DECEMBER 2004  
COPYRIGHT © 2005 ELECTIC ORANGE  
ALL RIGHTS RESERVED

5

6

7

8

F

E

D



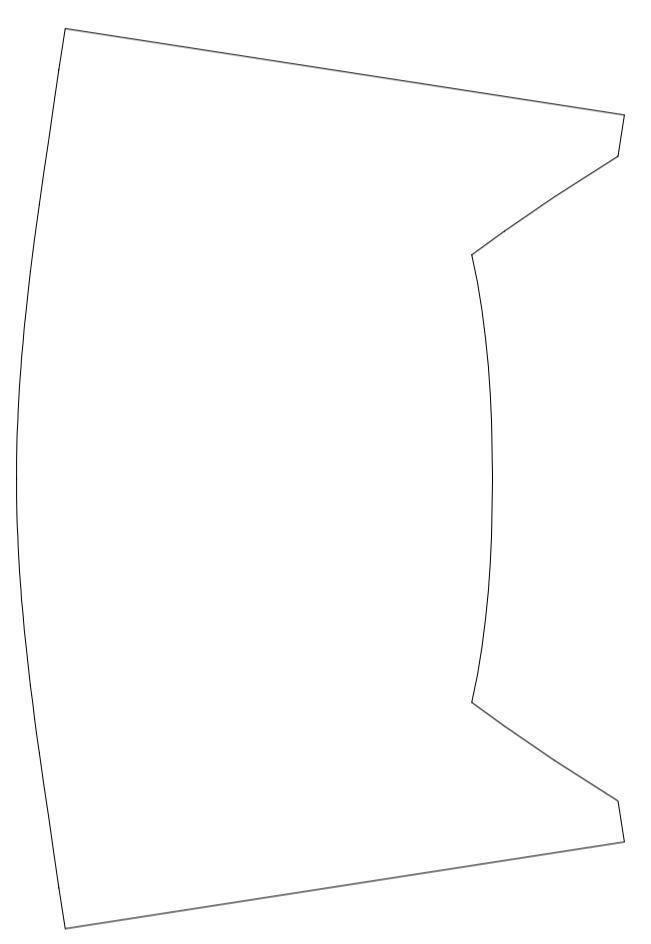
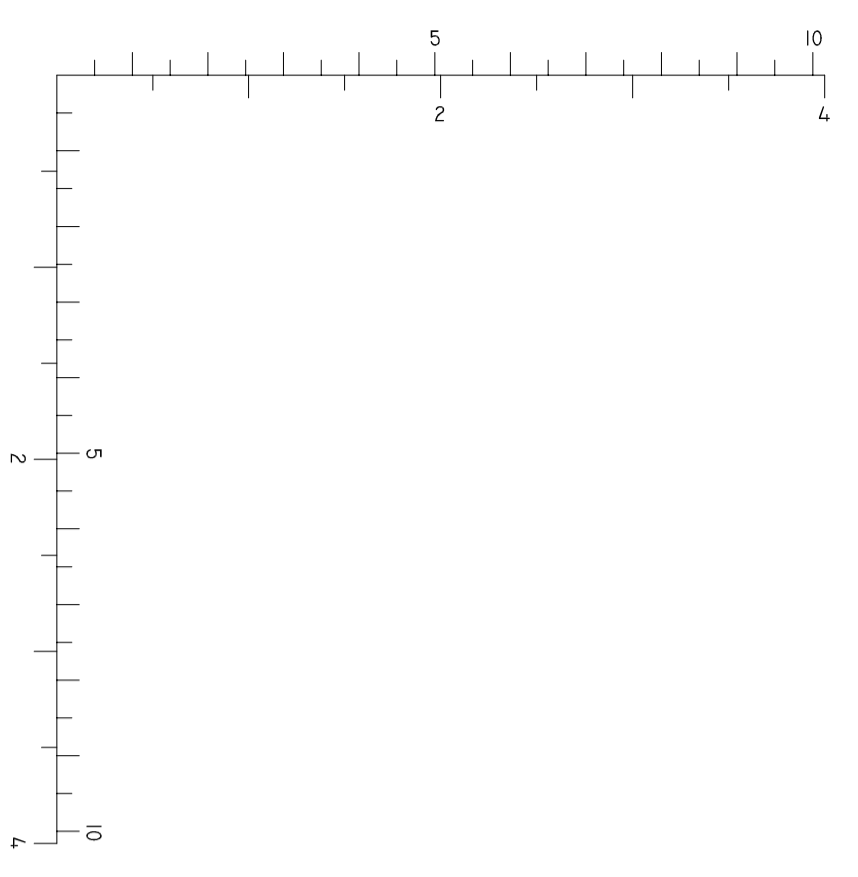

WINDSCREEN  
 MATERIAL: 0.5MM STYRENE  
 1 REQUIRED

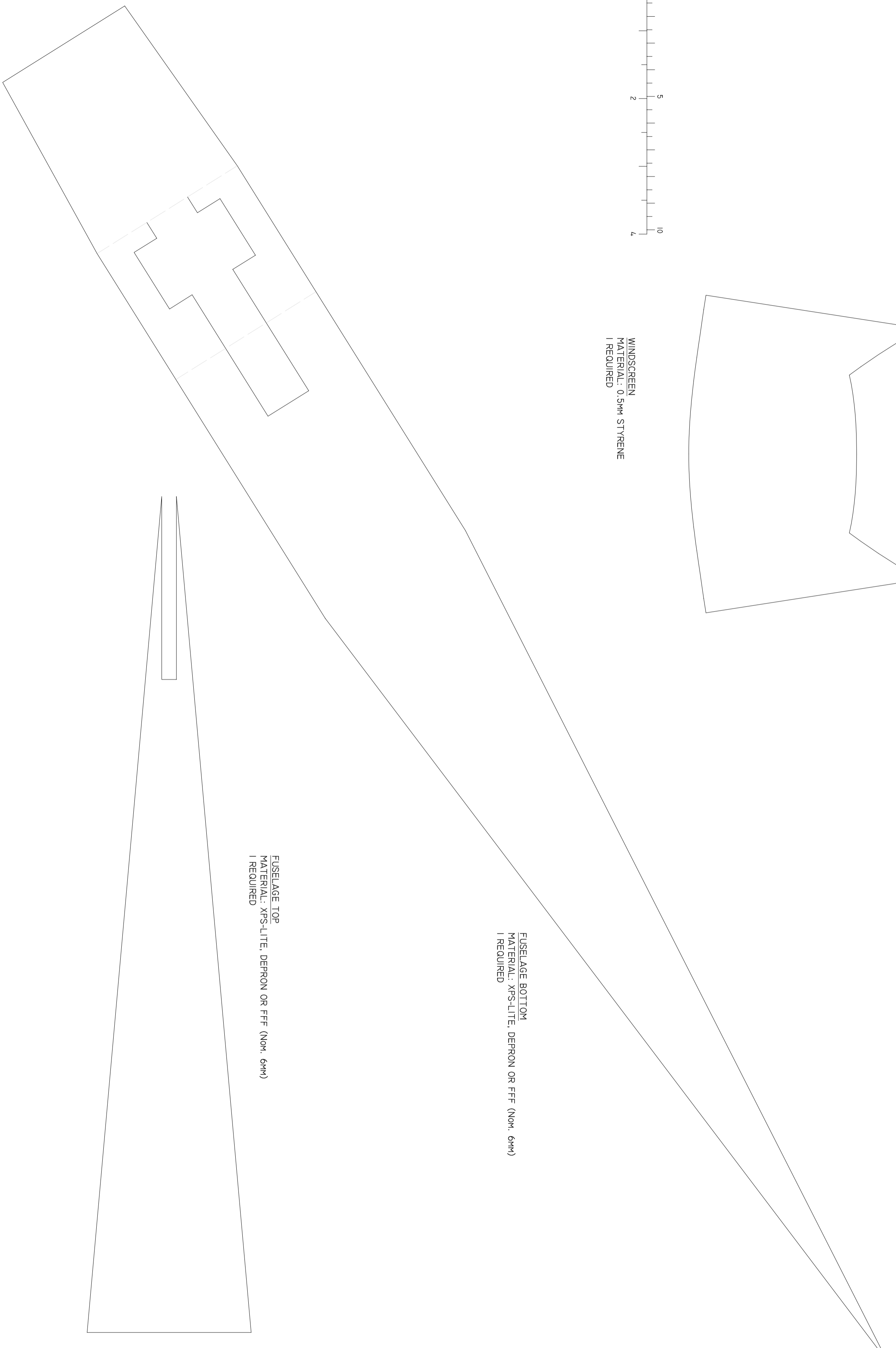

FUSELAGE BOTTOM  
 MATERIAL: XPS-LITE, DEPRON OR FFF (Nom. 6MM)  
 1 REQUIRED

FUSELAGE TOP  
 MATERIAL: XPS-LITE, DEPRON OR FFF (Nom. 6MM)  
 1 REQUIRED

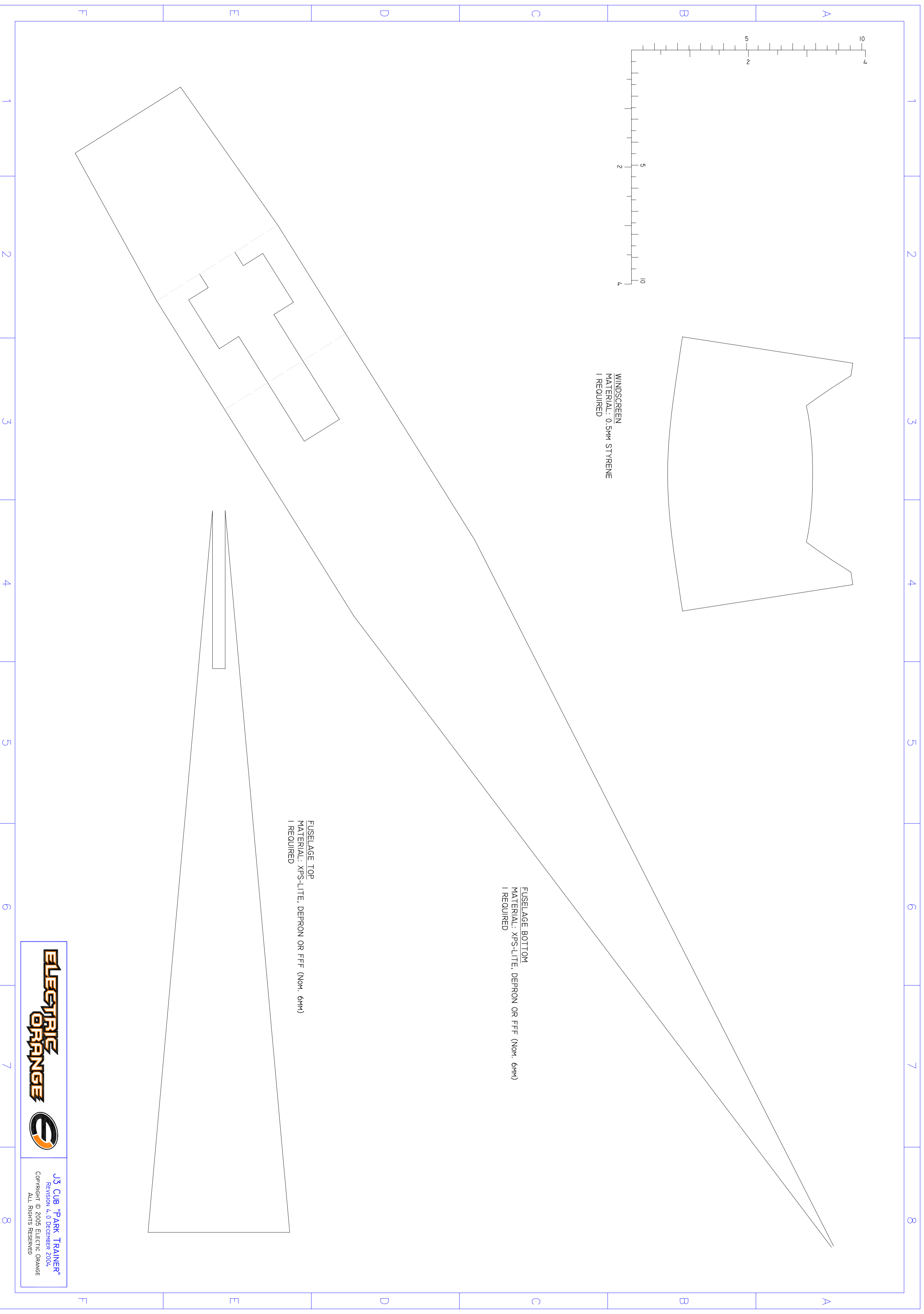

J3 CUB "PARK TRAINER"  
 REVISION 4, 0 DECEMBER 2004  
 COPYRIGHT © 2005 ELECTRIC ORANGE  
 ALL RIGHTS RESERVED

WINDSCREEN  
MATERIAL: 0.5MM STYRENE  
1 REQUIRED

FUSELAGE BOTTOM  
MATERIAL: XPS-LITE, DEPR  
1 REQUIRED

FUSELAGE TOP  
MATERIAL: XPS-LITE, DEPRON OR FFF (Nom.  
1 REQUIRED

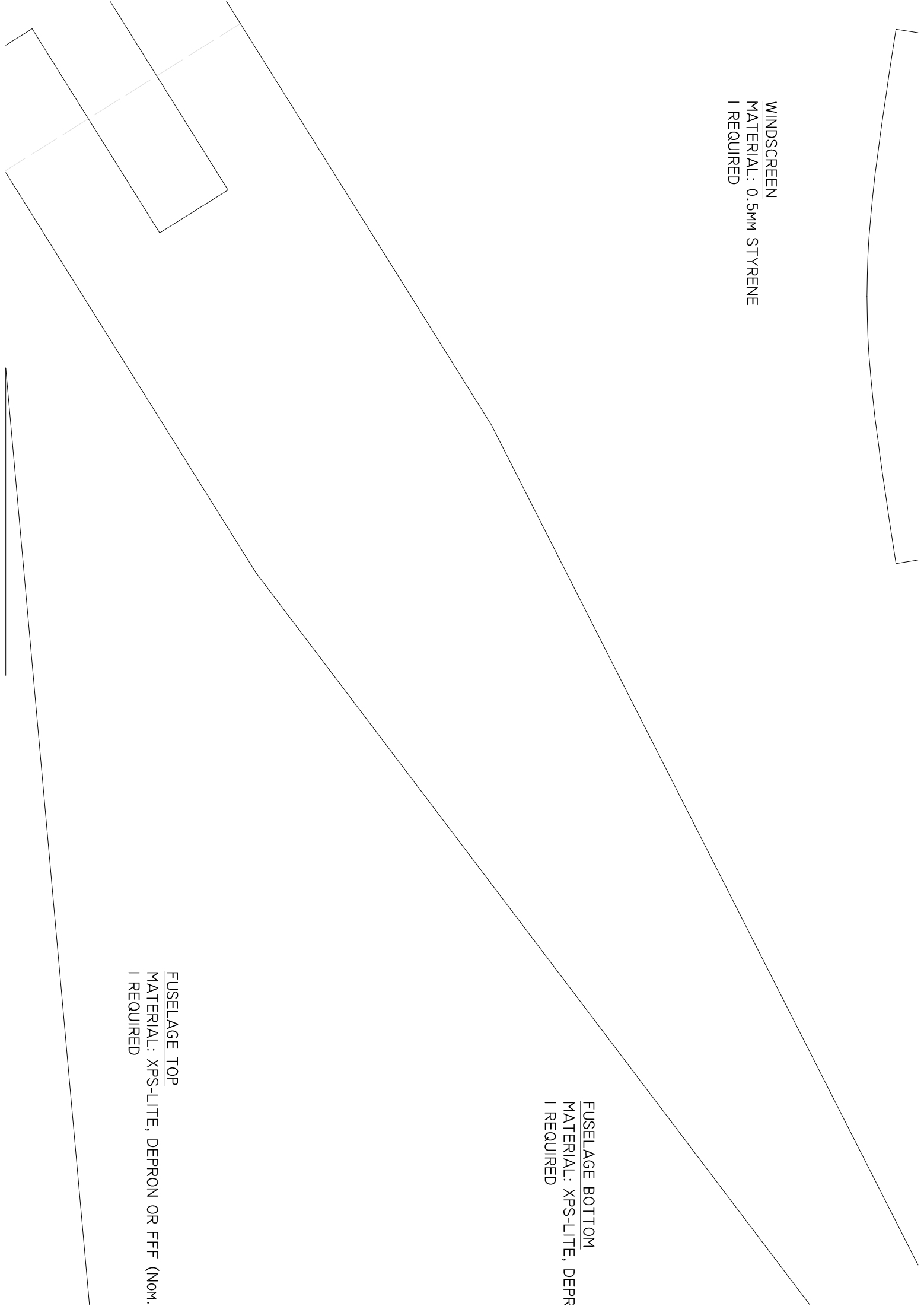

1 2 3 4

A

B

C

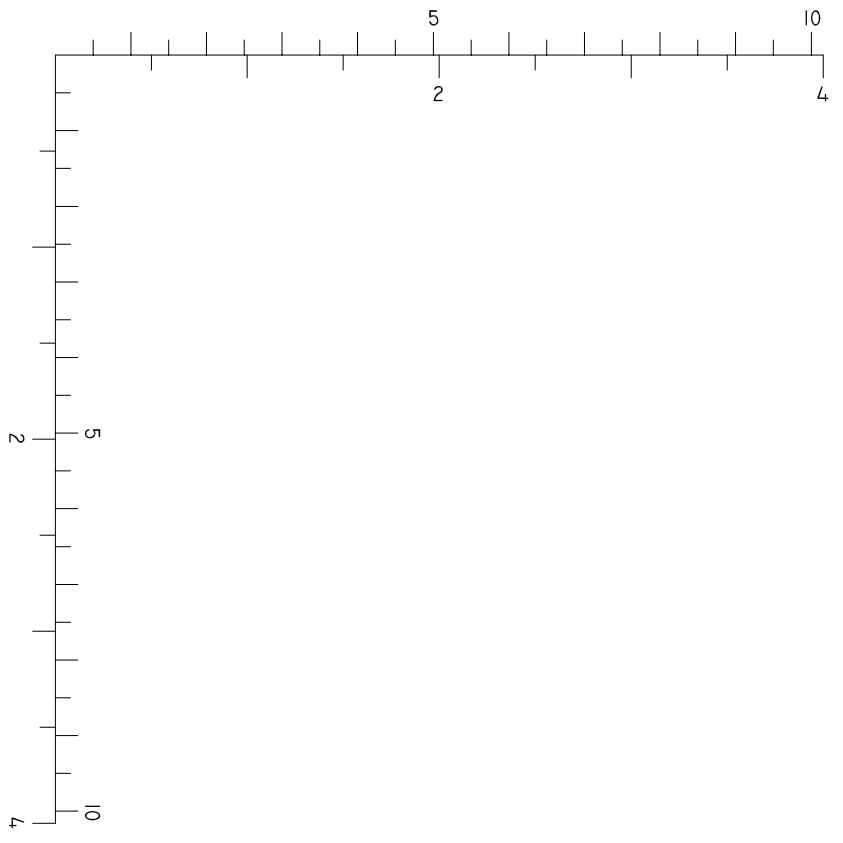

WINDSCREEN  
MATERIAL: 0.5MM STYRENE  
1 REQUIRED

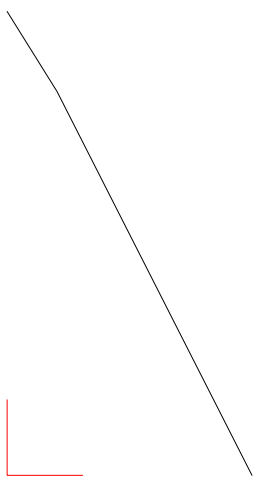

5

6

7

8

A

B

C

FUSELAGE BOTTOM  
MATERIAL: XPS-LITE, DEPRON OR FFF (Nom. 6mm)  
I REQUIRED

F

E

D

1

2

3

4

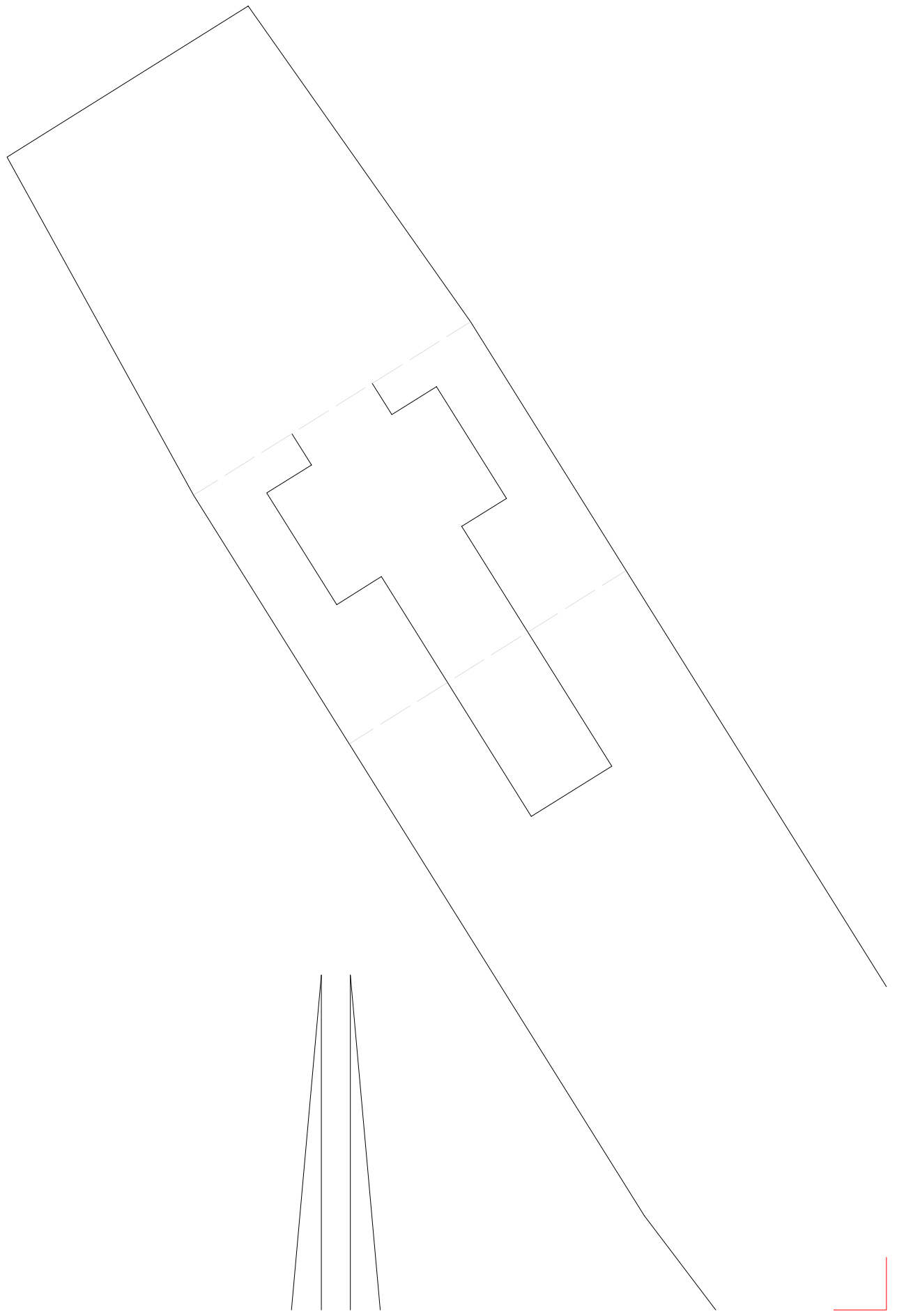

FUSELAGE TOP  
MATERIAL: XPS-LITE, DEPRON OR FFF (Nom. 6mm)  
I REQUIRED

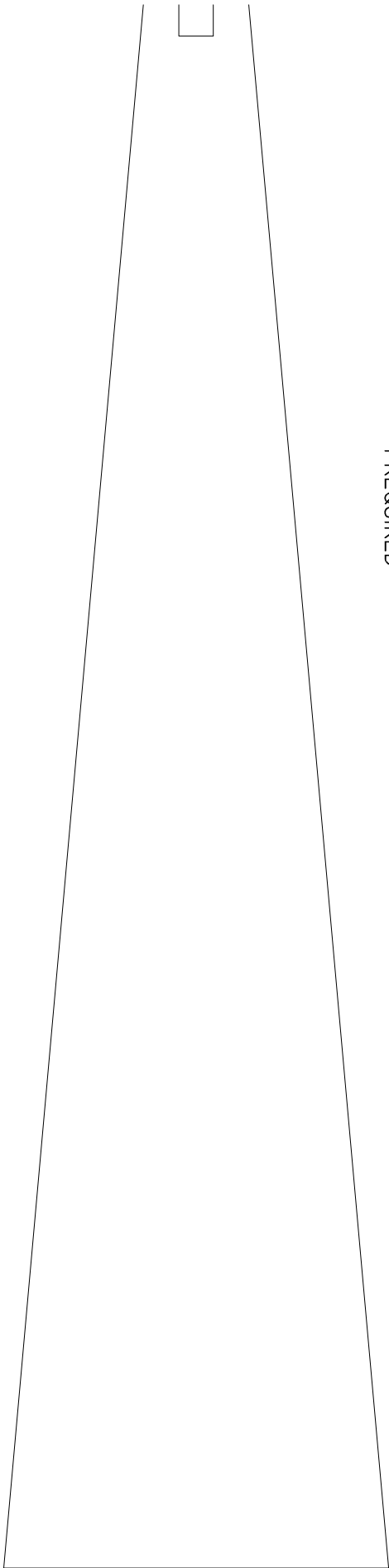

5

6

7

8

F

E

D

**ELECTRIC  
ORANGE**



**J3 CUB "PARK TRAINER"**  
REVISION 4, 0 DECEMBER 2004.  
COPYRIGHT © 2005 ELECTIC ORANGE  
ALL RIGHTS RESERVED

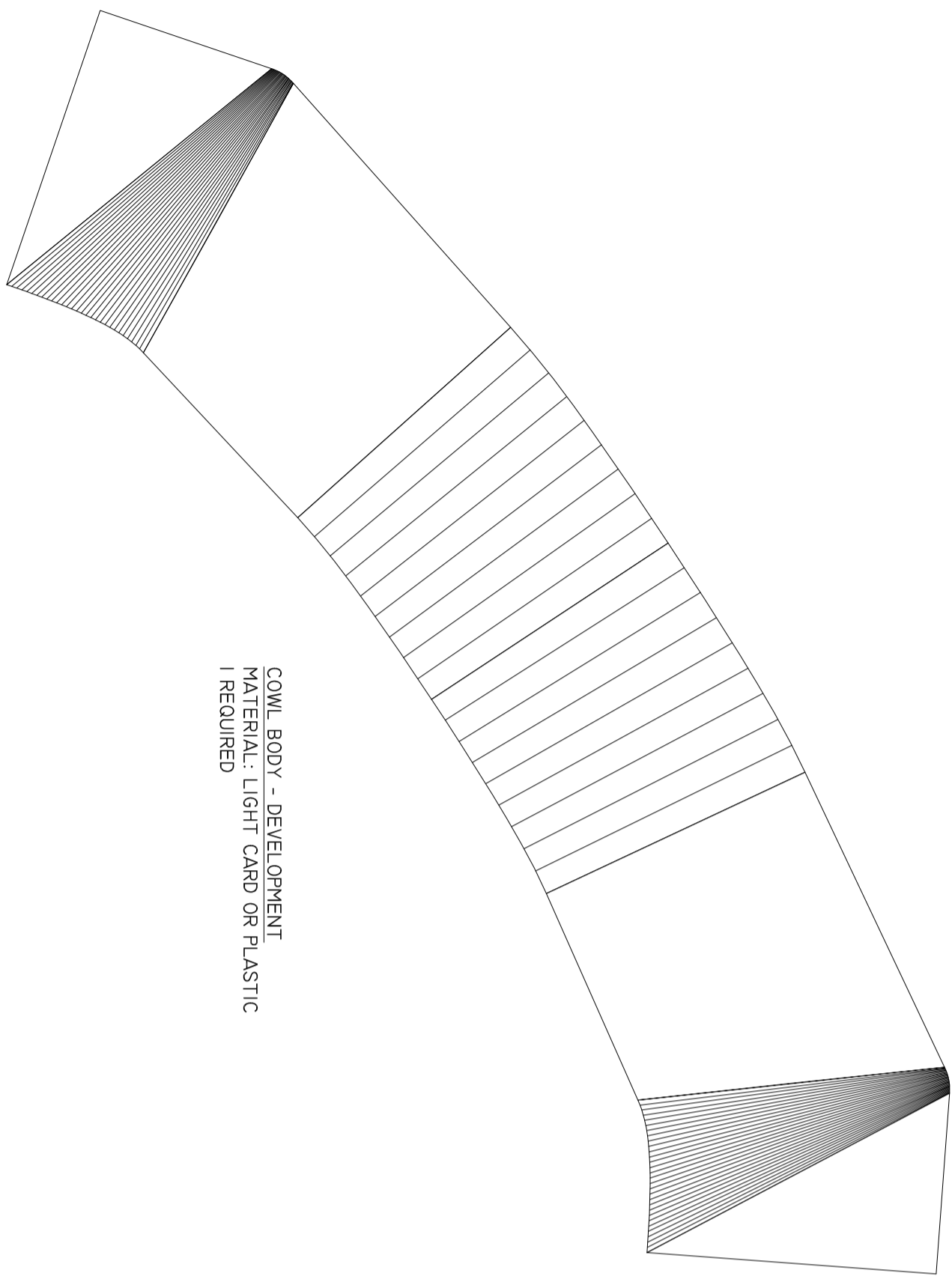

COWL BODY - DEVELOPMENT  
MATERIAL: LIGHT CARD OR PLASTIC  
1 REQUIRED

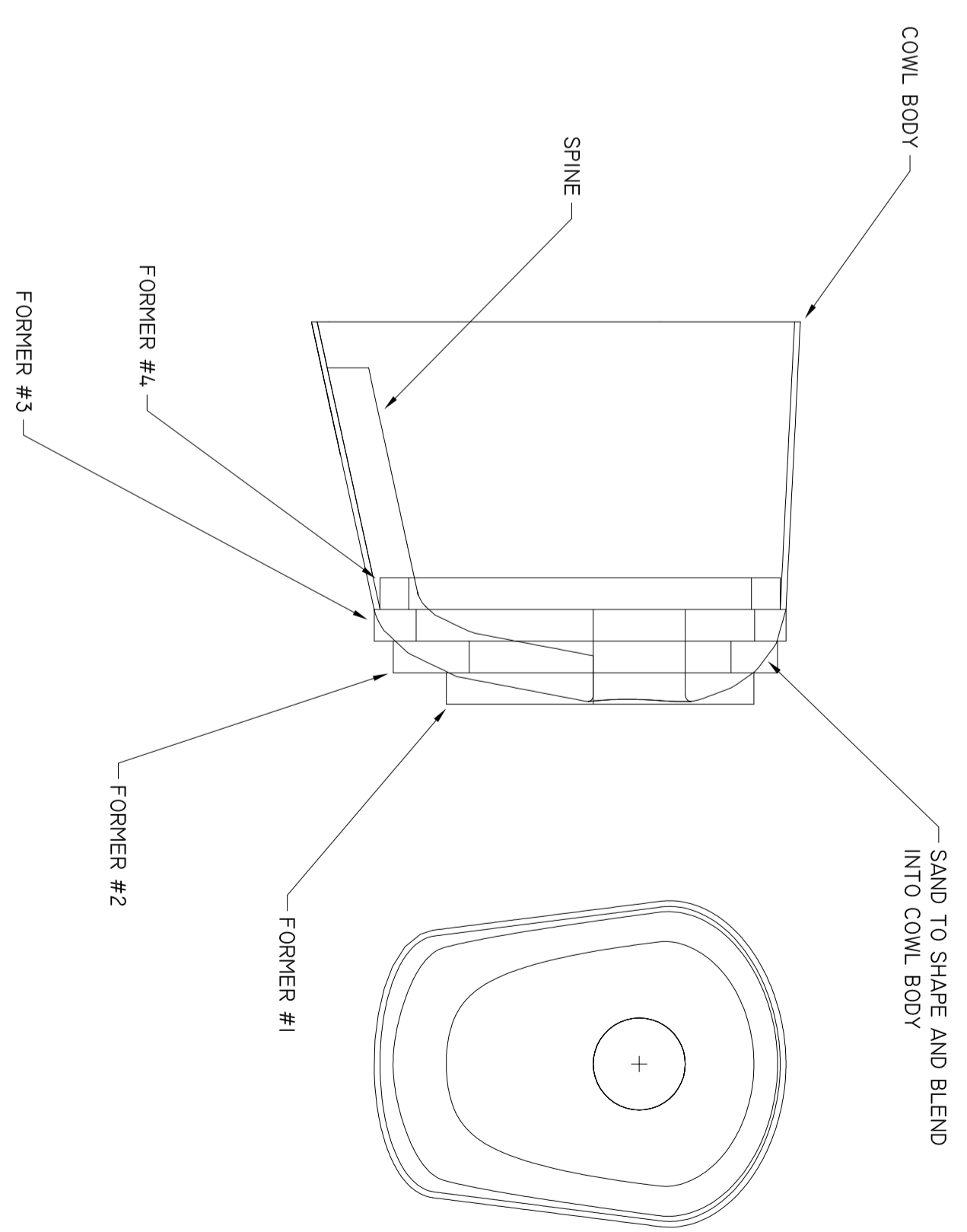

COWL FORMER #1  
MATERIAL: XPS-LITE, DEPRON OR FFF (Nom. 6mm)  
1 REQUIRED

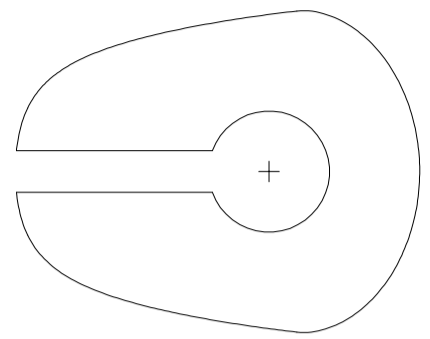

COWL FORMER #2  
MATERIAL: XPS-LITE, DEPRON OR FFF (Nom. 6mm)  
1 REQUIRED

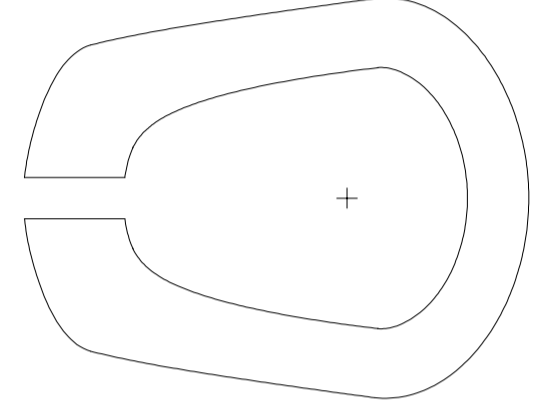

COWL SET-UP GAUGE  
MATERIAL: LIGHT CARD OR PLASTIC  
1 REQUIRED

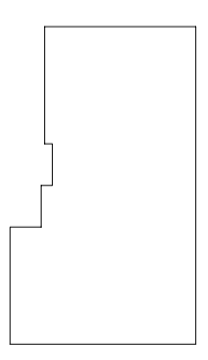

COWL FORMER #2  
MATERIAL: XPS-LITE, DEPRON OR FFF (Nom. 6mm)  
1 REQUIRED

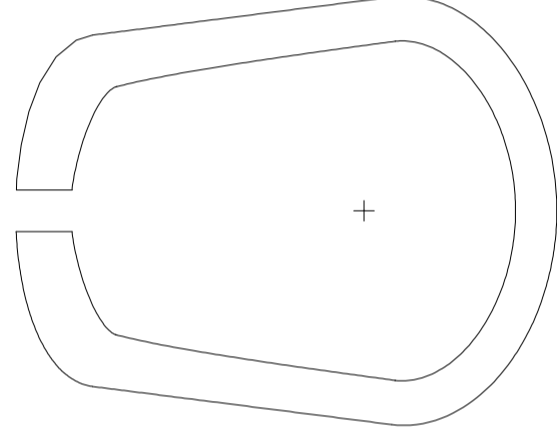

COWL FORMER #4  
MATERIAL: XPS-LITE, DEPRON OR FFF (Nom. 6mm)  
1 REQUIRED

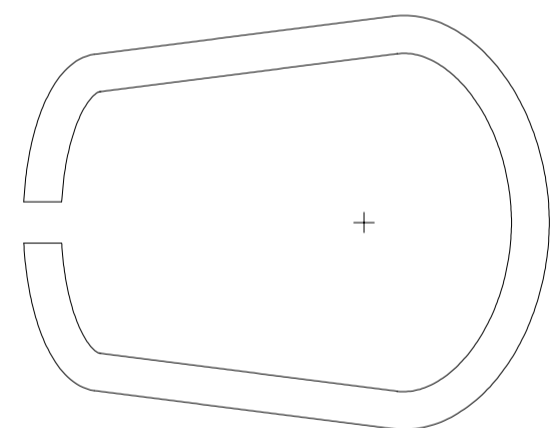

COWL SPINE  
MATERIAL: XPS-LITE, DEPRON OR FFF (Nom. 6mm)  
1 REQUIRED

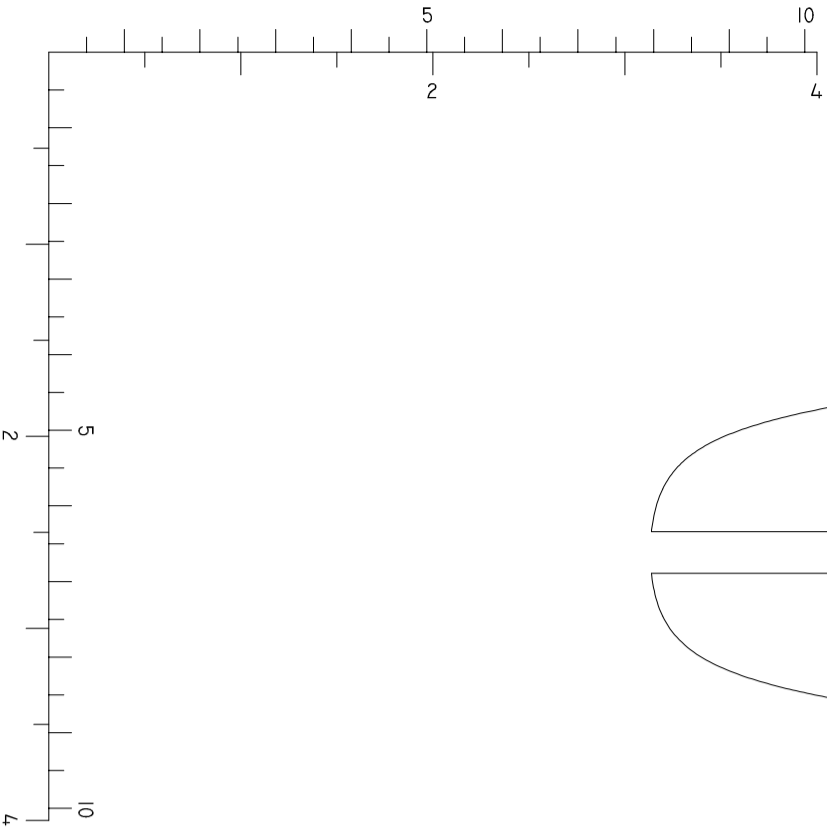
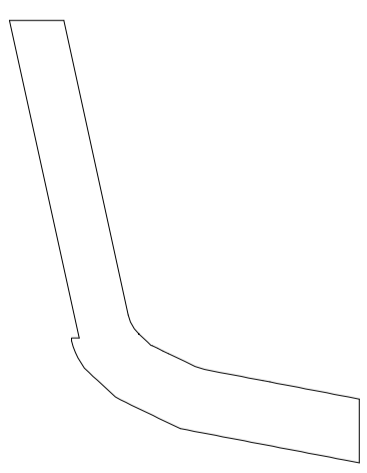

1 2 3 4

A

B

C

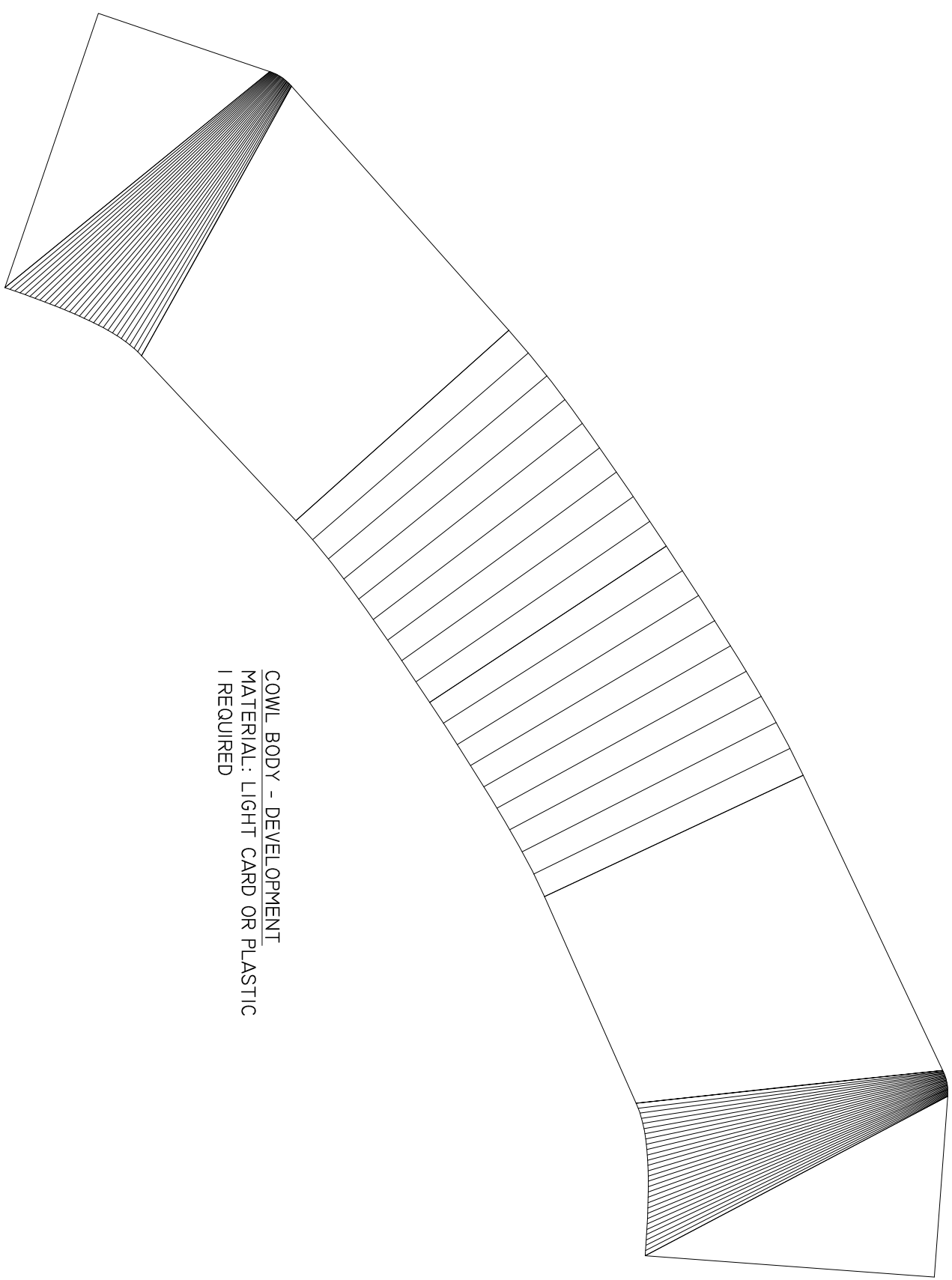

COWL BODY - DEVELOPMENT  
MATERIAL: LIGHT CARD OR PLASTIC  
1 REQUIRED



5

6

7

8

COWL BODY

SPINE

FORMER #4

FORMER #3

FORMER #2

FORMER #1

SAND TO SHAPE AND BLEND INTO COWL BODY

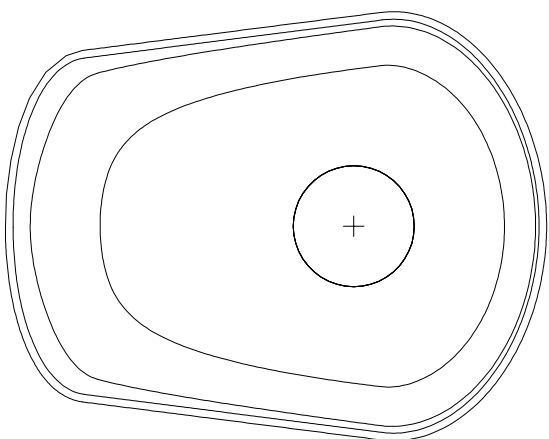

A

B

C

D

COWL FORMER #1  
MATERIAL: XPS-LITE, DEPRON OR FFF (Nom. 6mm)  
1 REQUIRED

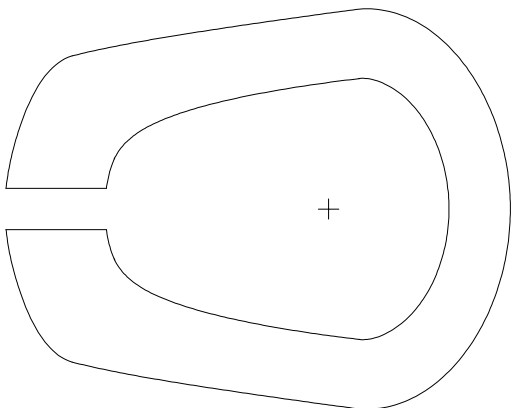
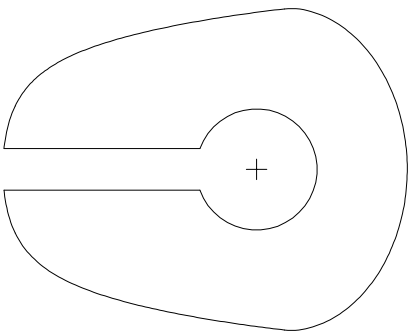

COWL FORMER #2  
MATERIAL: XPS-LITE, DEPRON OR FFF (Nom. 6mm)  
1 REQUIRED

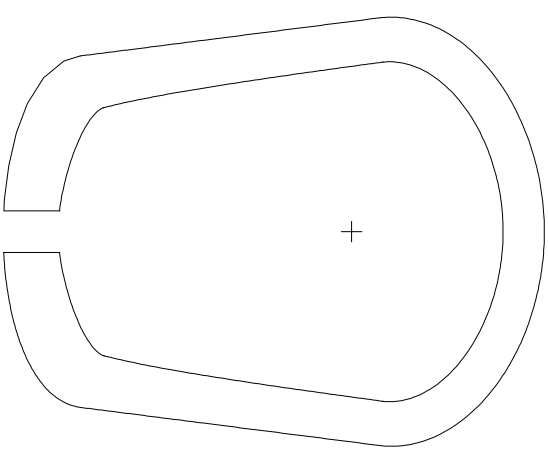

COWL FORMER #2  
MATERIAL: XPS-LITE, DEPRON OR FFF (Nom. 6mm)  
1 REQUIRED

E

F

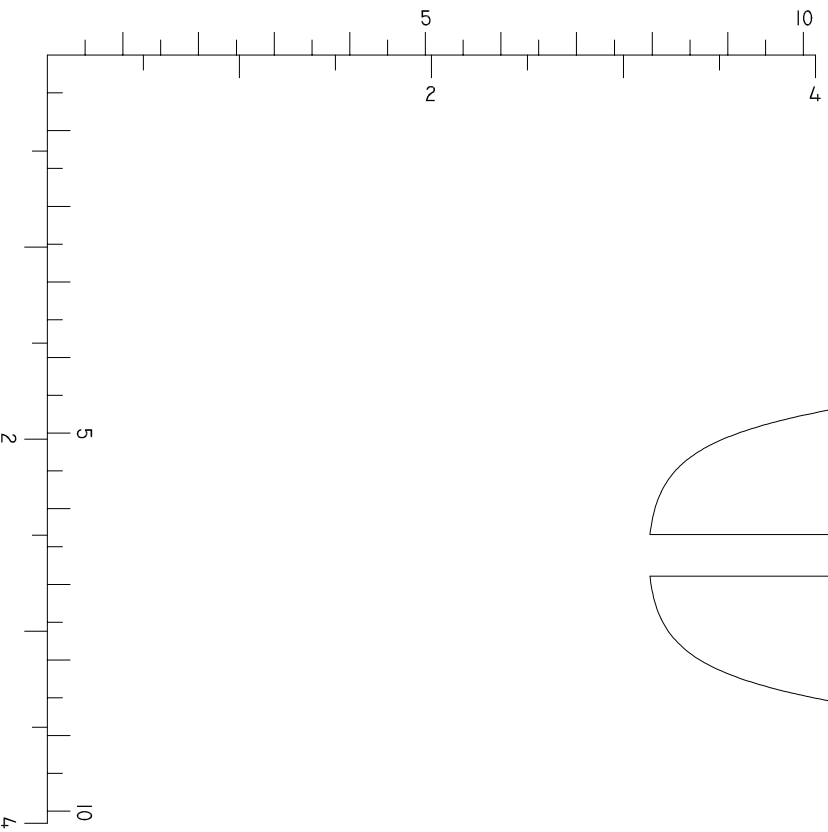

1

2

3

4

1. 6MM)

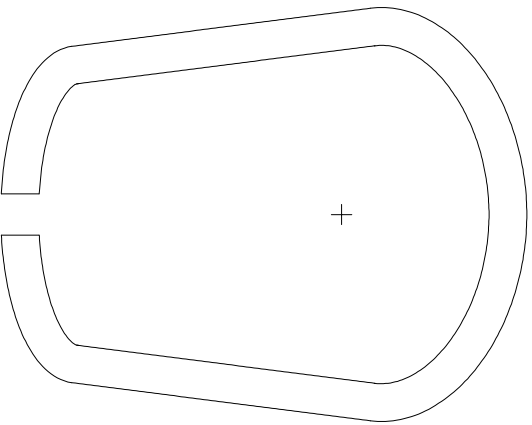

COWL FORMER #4  
MATERIAL: XPS-LITE, DEPRON OR FFF (Nom. 6MM)  
1 REQUIRED

COWL SET-UP GAUGE  
MATERIAL: LIGHT CARD OR PLASTIC  
1 REQUIRED

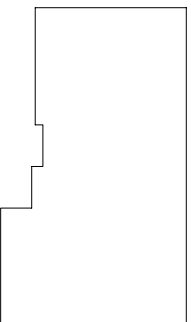

COWL SPINE  
MATERIAL: XPS-LITE, DEPRON OR FFF (Nom. 6MM)  
1 REQUIRED

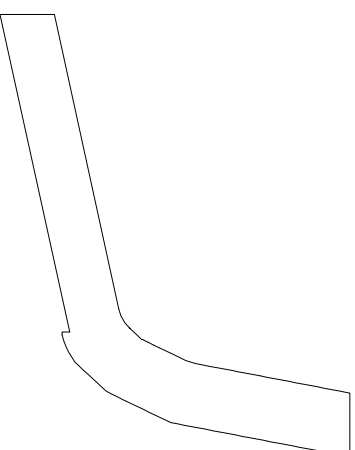

5

6

7

8

**ELECTRIC  
ORANGE**



**J3 CUB "PARK TRAINER"**  
REVISION 4, 0 DECEMBER 2004.  
COPYRIGHT © 2005 ELECTIC ORANGE  
ALL RIGHTS RESERVED

F

E

D

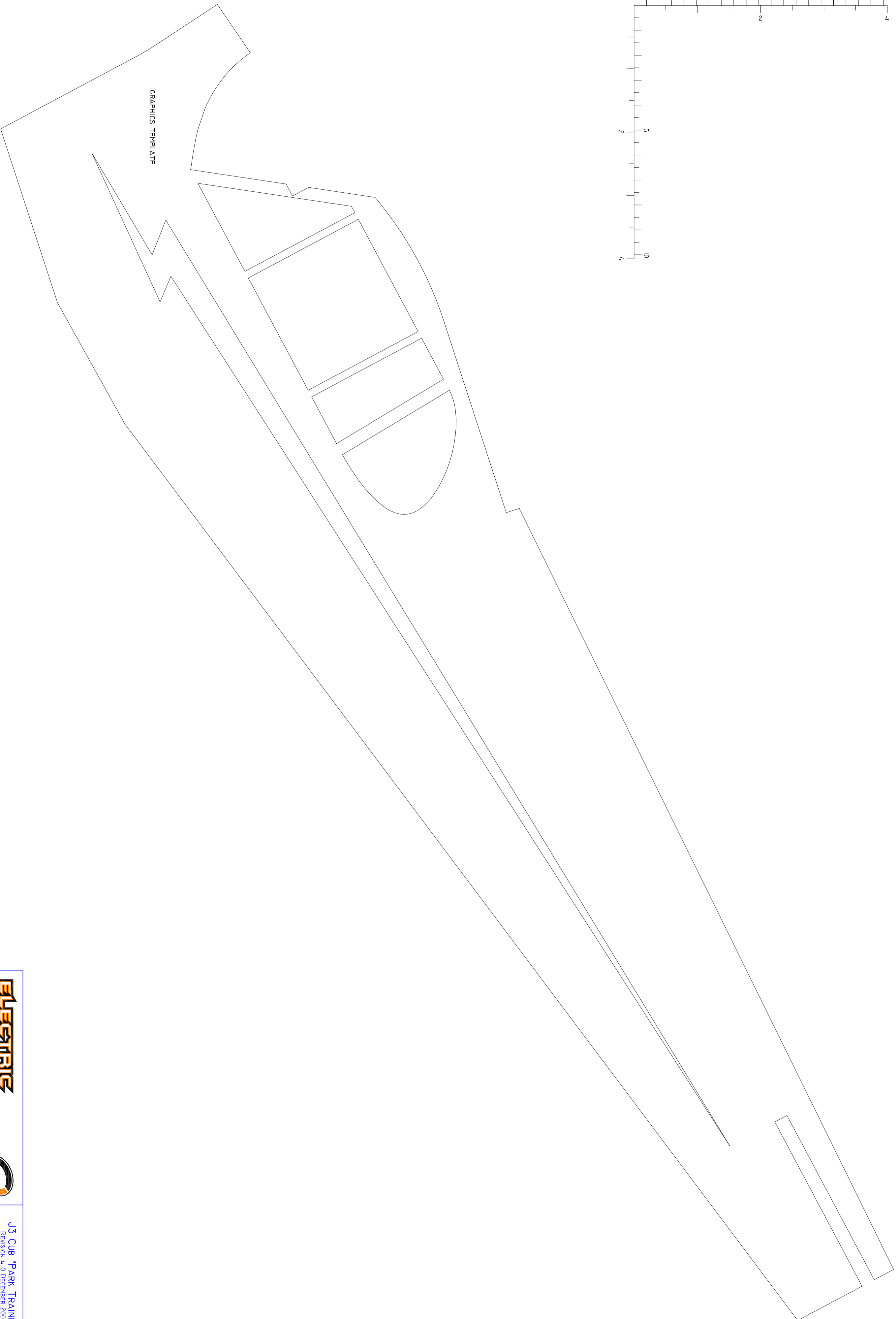
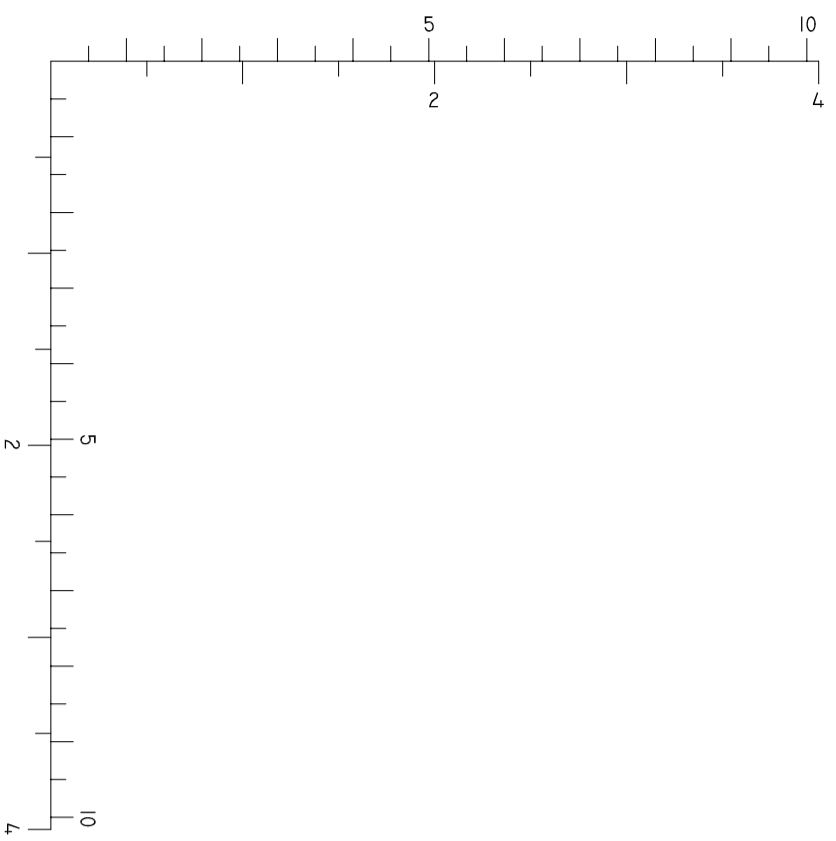

GRAPHICS TEMPLATE

**ELECTRIC ORANGE**



J3 CUB "PARK TRAINER"  
REVISION 4, 0 DECEMBER 2004  
COPYRIGHT © 2005 ELECTRIC ORANGE  
ALL RIGHTS RESERVED

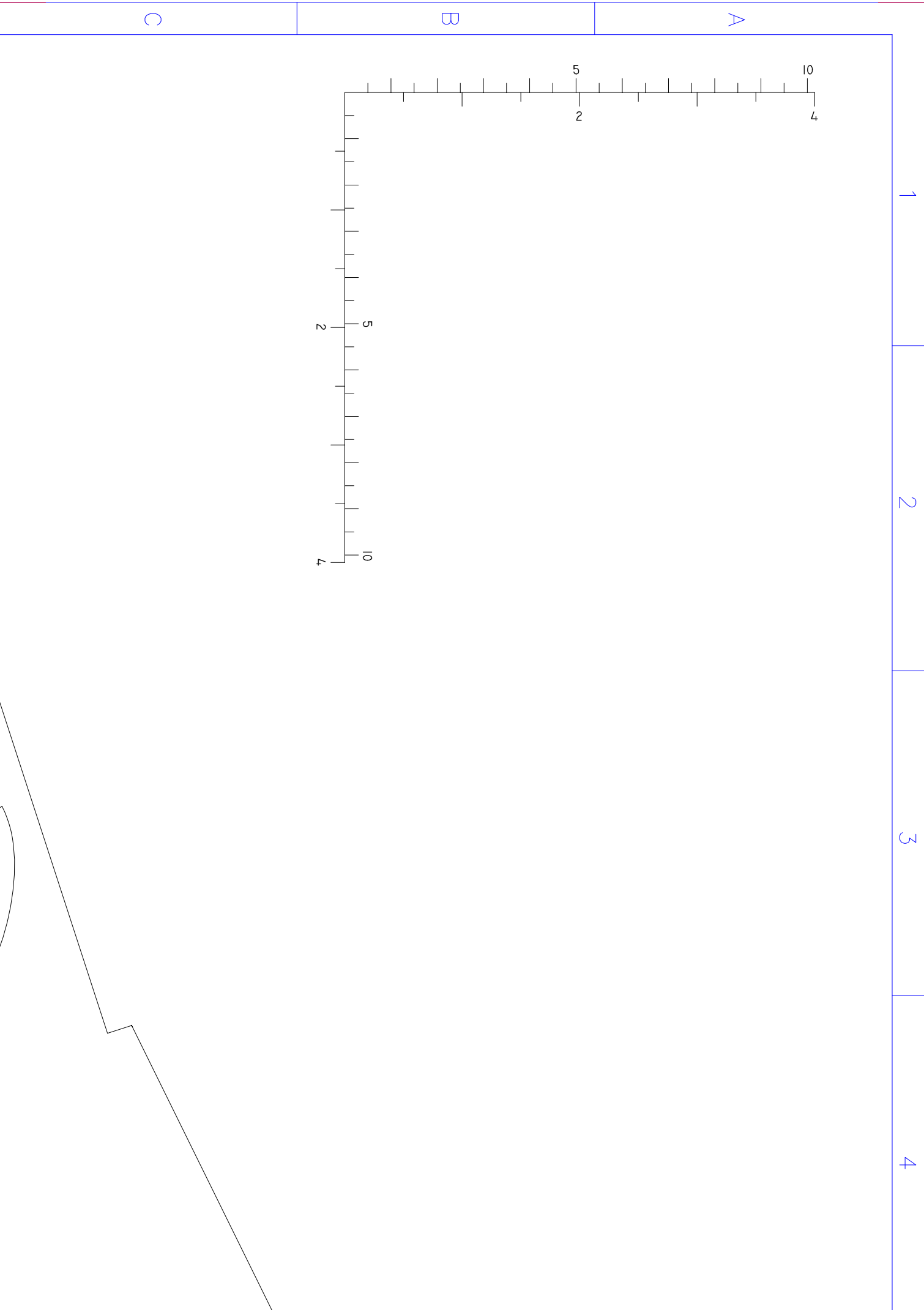

5

6

7

8

A

B

C

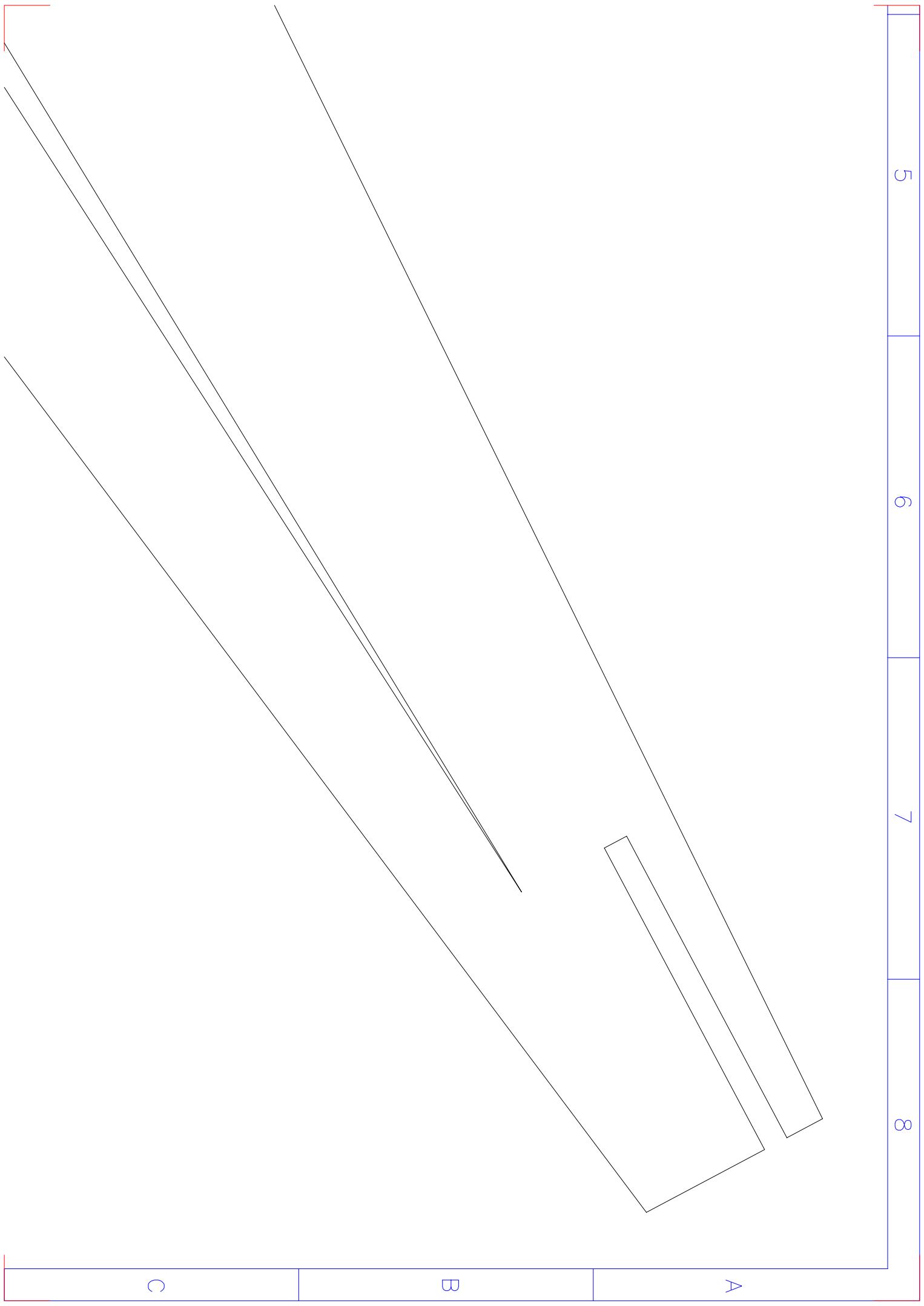

D

E

F

1

2

3

4

GRAPHICS TEMPLATE

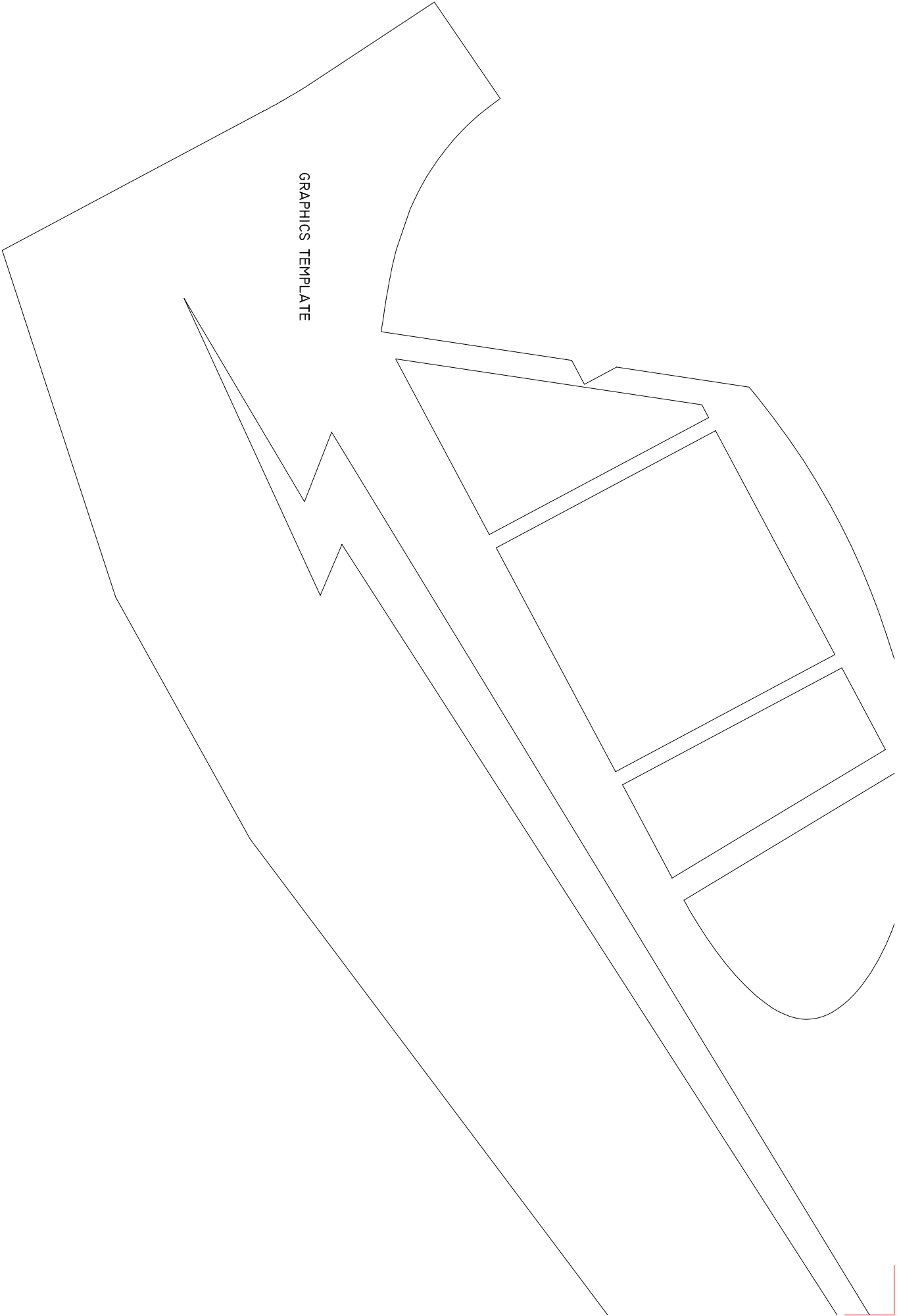

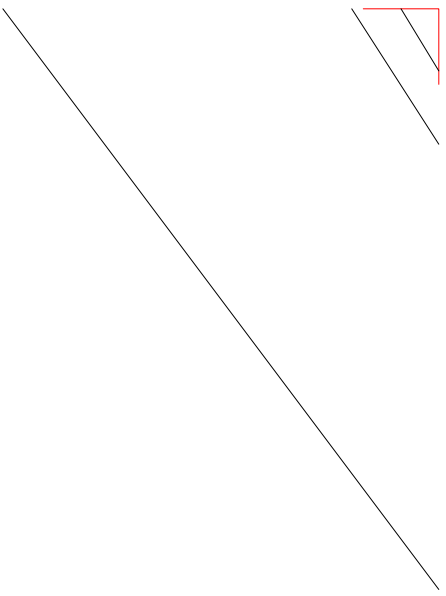
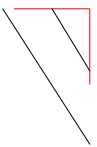

5

6

7

8



J3 CUB "PARK TRAINER"  
REVISION 4, 0 DECEMBER 2004,  
COPYRIGHT © 2005 ELECTIC ORANGE  
ALL RIGHTS RESERVED

F

E

D