

STEERING CONTROL MECHANISM

AJMAL HUSSAIN (ME10B001)

AKASH SUBUDHI (ME10B002)

ALBIN ABRAHAM (ME10B003)

PAWAN KUMAR (ME10B023)

YOGITHA MALPOTH (ME10B024)

ZAID AHSAN (ME10B043)

SHANTI SWAROOP KANDALA (ME14RESCH01001)

OUTLINE

- Introduction
- Types of steering
- Cad models
- Role of cornering stiffness
- Lateral control system
- Electric power assisted steering
- Optimization using genetic algorithm
- Conclusion

INTRODUCTION

- Collection of components which allows to follow the desired course.
- In a car : ensure that wheels are pointing in the desired direction of motion.
- Convert rotary motion of the steering to the angular turn of the wheel.
- Mechanical advantage is used in this case.
- The joints and the links should be adjusted with precision.
- Smallest error can be dangerous
- Mechanism should not transfer the shocks in the road to the driver's hands.
- It should minimize the wear on the tyres.

RACK AND PINION STEERING SYSTEM

- The pinion moves the rack converting circular motion into linear motion along a different axis
- Rack and pinion gives a good feedback there by imparts a feel to the driving
- Most commonly used system in automobiles now.
- Disadvantage of developing wear and there by backlash.



RECIRCULATING BALL

- Used in Older automobiles
- The steering wheel rotates the shaft which turns the worm gear.
- Worm gear is fixed to the block and this moves the wheels.
- More mechanical advantage.
- More strength and durable

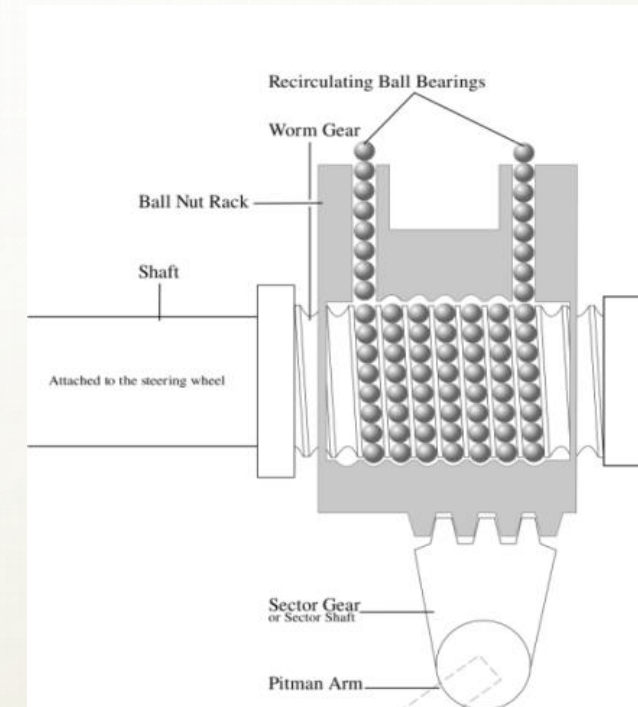

POWER STEERING

- Too much physical exertion was needed for vehicles
- External power is only used to assist the steering effort.
- Power steering gives a feedback of forces acting on the front wheel to give a sense of how wheels are interacting with the road.
- Hydraulic and electric systems were developed.
- Also hybrid hydraulic-electric systems were developed.
- Even if the power fails, driver can steer only it becomes more heavier.

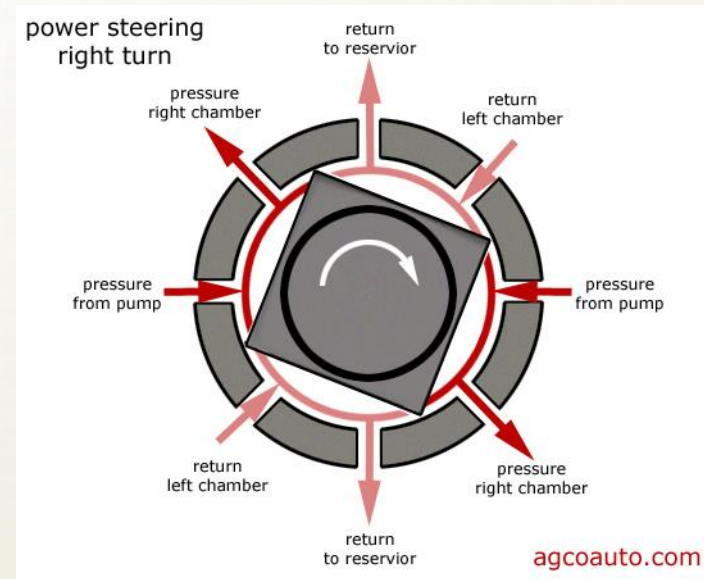
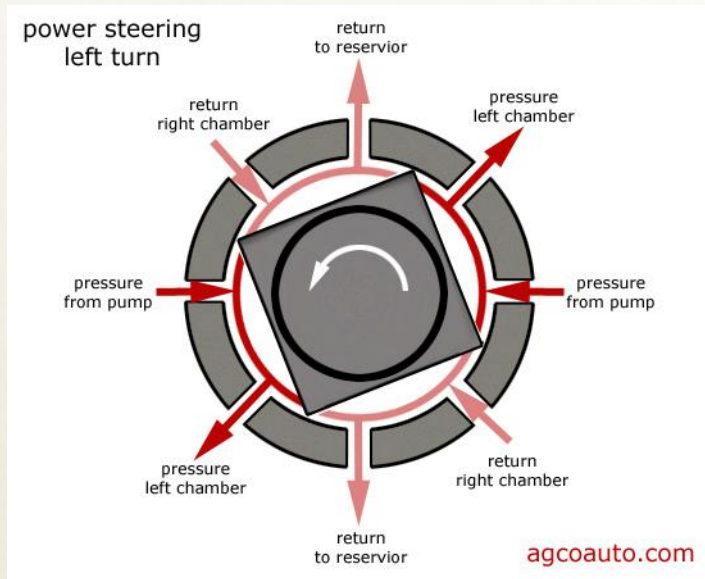
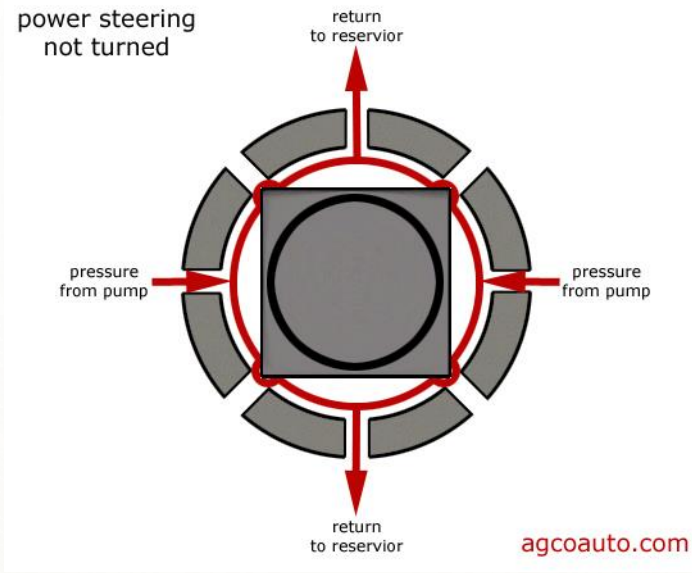

COMPONENTS

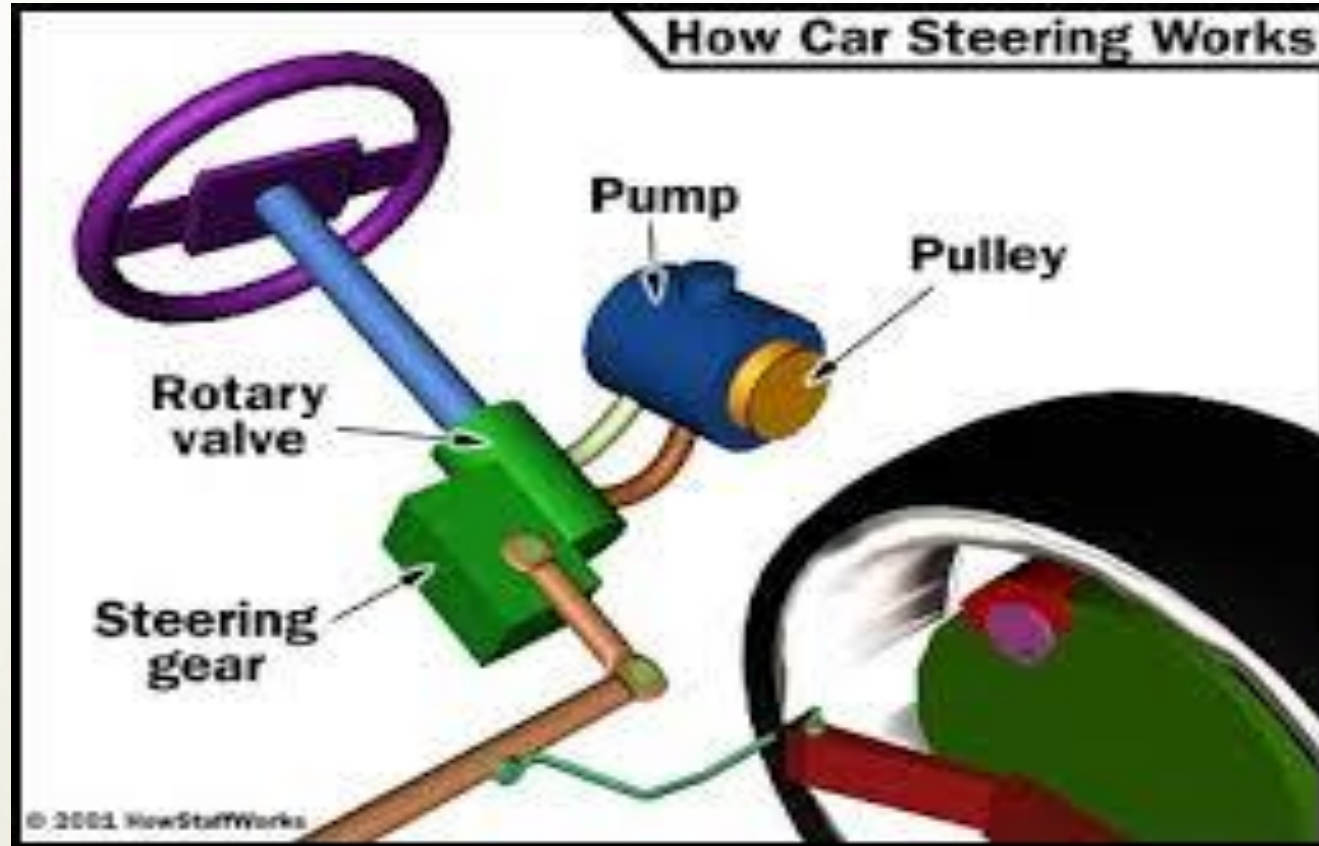

ELECTRIC POWER STEERING

- Uses an electric motor to assist the driving
- Sensors detect the position of the steering column.
- An electronic module controls the effort to be applied depending on the conditions.
- The module can be customised to apply varying amounts of assistance depending on driving conditions.
- The assistance can also be tuned depending on vehicle type, driver preferences

HYDRAULIC VS ELECTRIC

- Electric eliminates the problems of dealing with leakage and disposal of the hydraulic fluid.
- Another issue is that if the hydraulic system fails, the driver will have to spent more effort since he has to turn the power assistance system as well as the vehicle using manual effort.
- Hydraulic pump must be run constantly where as electric power is used accordingly and is more energy efficient.
- Hyrdraulic is more heavy, complicated, less durable and needs more maintenance.
- Hydraulic takes the power directly from the engine so less mileage.

SPEED SENSITIVE STEERING

- There is more assistance at lower speeds and less at higher speeds.
- Diravi is the first commercially available variable power steering system introduced by Citroën.
- A centrifugal regulator driven by the secondary shaft of the gearbox gives a proportional hydraulic pressure to the speed of the car
- This pressure acts on a cam directly revolving according to the steering wheel.
- This gives an artificial steering pressure by trying to turn back the steering to the central position
- Newer systems control the assistance directly

AUDI R8



- Comes in three variants coupe, sport and spyder.
- Audi r8 is hailed as one of the best road handling cars.
- Audi r8 beat the porsche 997- considered to be one of the best sports cars ever made in top gear's test.



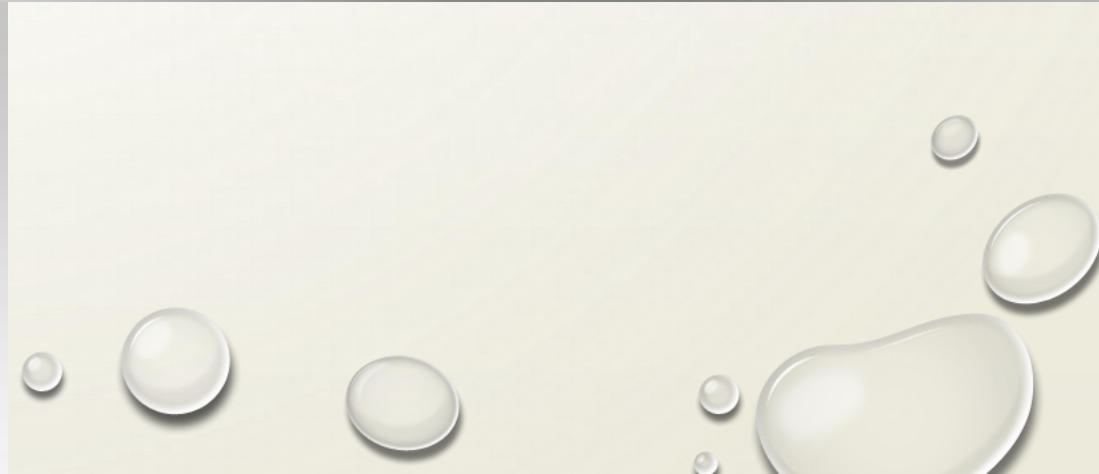
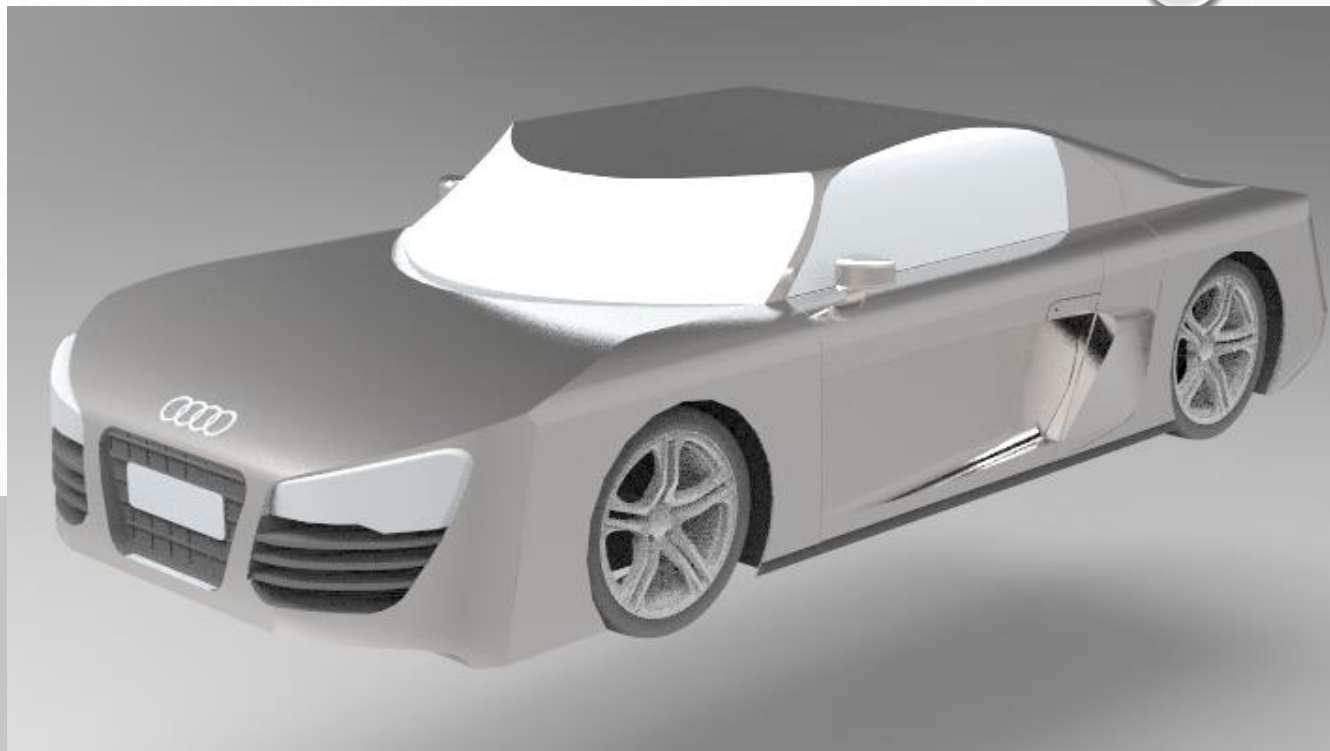







STEERING CAD MODEL

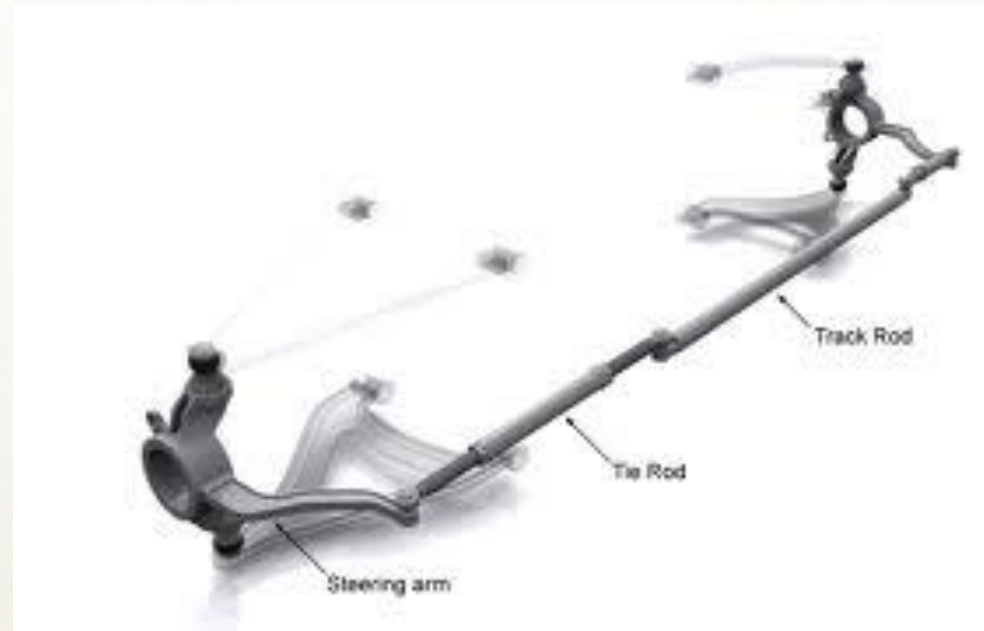

$$mU(r + \dot{\beta}) = \sum \text{Lateral Force} = \sum \mathbf{F},$$

$$J\dot{r} = \sum \text{Yaw Moment} = \sum \mathbf{N},$$

$$a_c = U(\dot{\beta} + r).$$

$$a_s = a_c + l_s \dot{r} = U(\dot{\beta} + r) + l_s \dot{r}.$$

$$Y_f = C_f \alpha_f,$$

$$Y_r = C_r \alpha_r.$$

$$Y_f = C_f \tau - C_f \beta - \frac{h_f C_f}{U} r,$$

$$Y_r = -C_r \beta + \frac{h_r C_r}{U} r.$$

FINAL EQUATIONS

$$mU(r + \dot{\beta}) = \sum \mathbf{F} = F_f + F_r = -(C_f + C_r)\beta + \frac{1}{U}(h_r C_r - h_f C_f)r + C_f \tau,$$

$$J\dot{r} = \sum \mathbf{N} = h_f F_f - h_r F_r = (h_r C_r - h_f C_f)\beta - \frac{1}{U}(h_f^2 C_f + h_r^2 C_r)r.$$

$$a_s = \left\{ -(C_f + C_r)/m + l_s(h_r C_r - h_f C_f)/J \right\} \beta + \left\{ (h_r C_r - h_f C_f)/mU - l_s(h_f^2 C_f + h_r^2 C_r)/JU \right\} r + [C_f/m + l_s(h_f C_f/J)] \tau.$$

STATE SPACE EQUATIONS

$$\begin{bmatrix} \dot{\beta} \\ r \end{bmatrix} = \begin{bmatrix} a_{11} & a_{12} \\ a_{21} & a_{22} \end{bmatrix} \begin{bmatrix} \beta \\ r \end{bmatrix} + \begin{bmatrix} b_1 \\ b_2 \end{bmatrix}$$

$$\begin{bmatrix} a_s \\ \beta \\ r \end{bmatrix} = \begin{bmatrix} c_{11} & c_{12} \\ 1 & 0 \\ 0 & 1 \end{bmatrix} \begin{bmatrix} \beta \\ r \end{bmatrix} + \begin{bmatrix} d_1 \\ 0 \\ 0 \end{bmatrix}$$

The matrices of the state space equations are given



The elements of these matrices change due to variation in C and load



The new matrices are calculated



`sys=ss(A,B,C,D)`



The transfer functions are then given by,
`tf()sys`

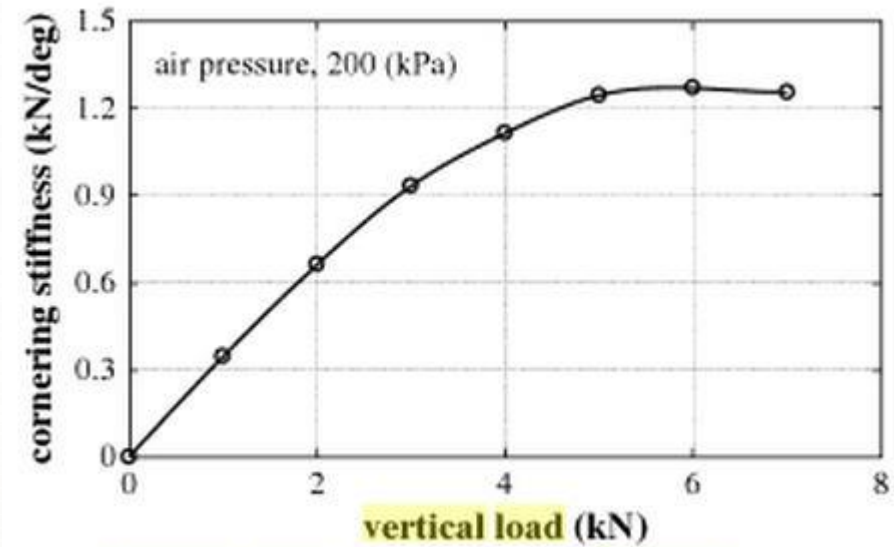

```
A(1,1)=-(Cr+Cf)/(m*U);
A(2,1)=(hr*Cr-hf*Cf)/J;
A(1,2)=-1+((hr*Cr-hf*Cf)/(m*(U^2)));
A(2,2)=-((hr^2)*Cr+(hf^2)*Cf)/(J*U);

B(1,1)=Cf/(m*U);
B(2,1)=hf*Cf/J;

C(1,1)=-((Cf+Cr)/m)+ls*(hr*Cr-hf*Cf)/J;
C(1,2)=((hr*Cr-hf*Cf)/(m*U))-ls*(((hr^2)*Cr+(hf^2)*Cf)/(J*U));
C(2:3,1:2)=eye(2,2);

D(1,1)=(Cf/m)+ls*(hf*Cf/J);

sys=ss(A,B,C,D);
tf(sys)
```

STABLE AND UNSTABLE REGIONS VARYING CORNERING STIFFNESS

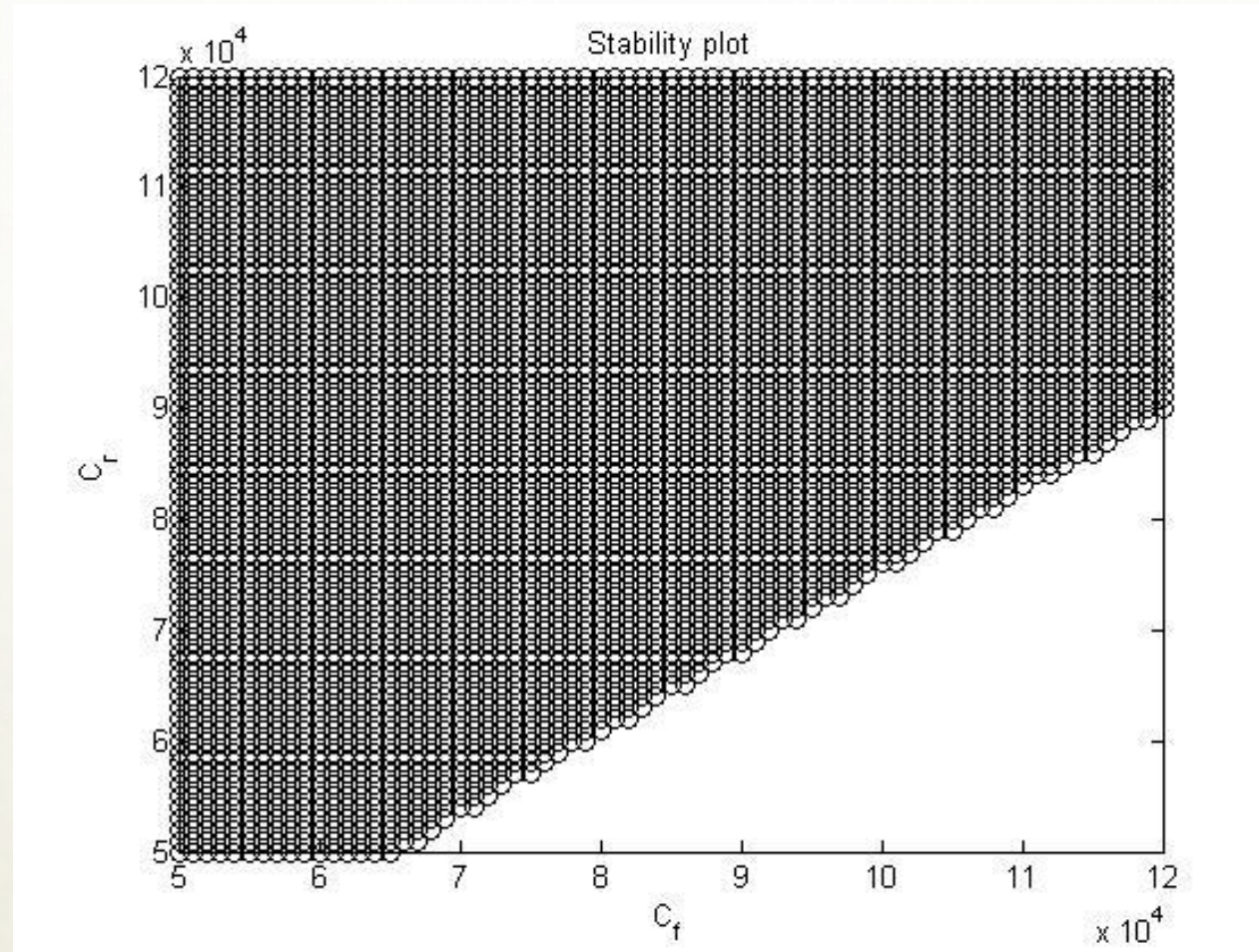

$M=3000$ kg

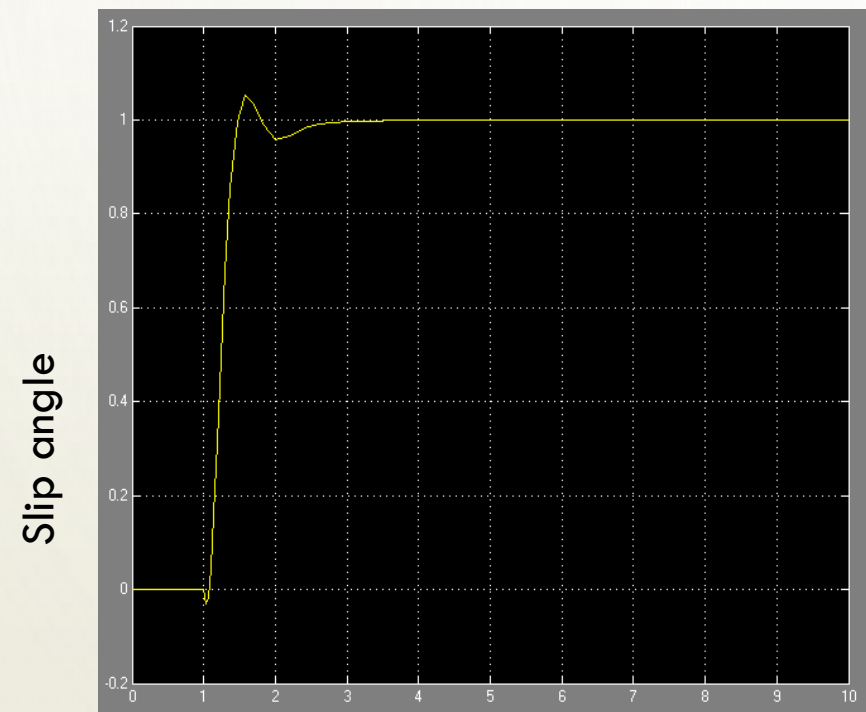

Time

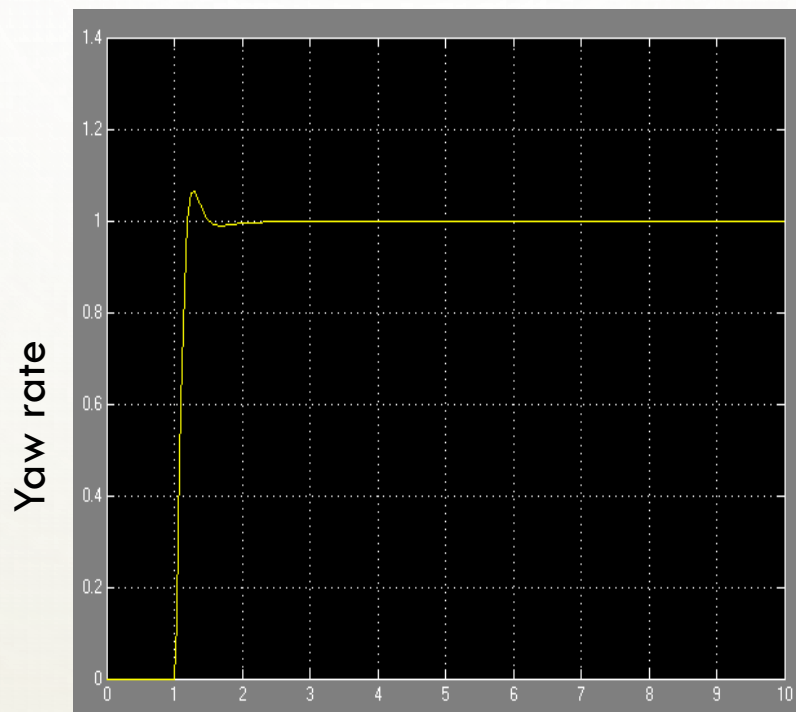

Time

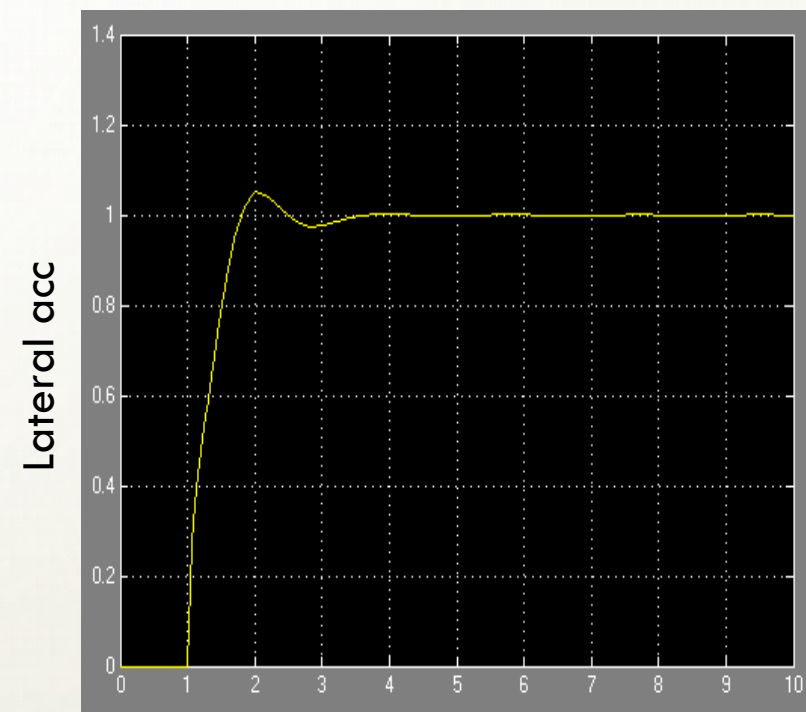

Time

$M=4000$ kg

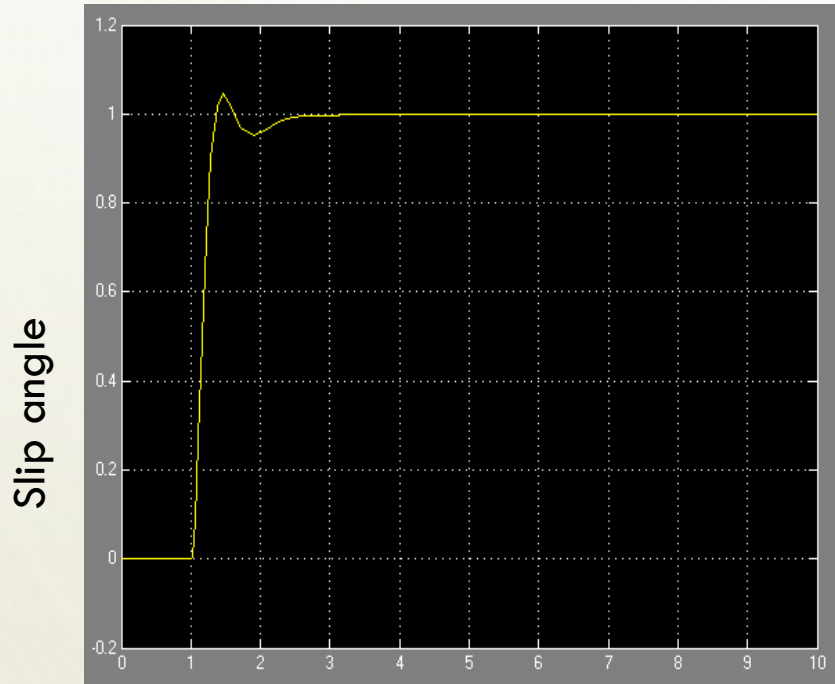

Time

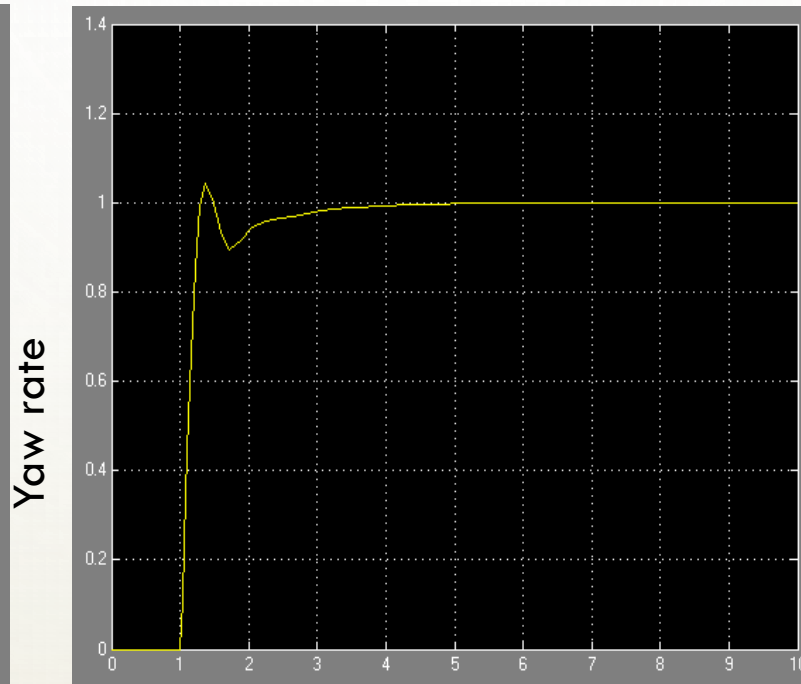

Time

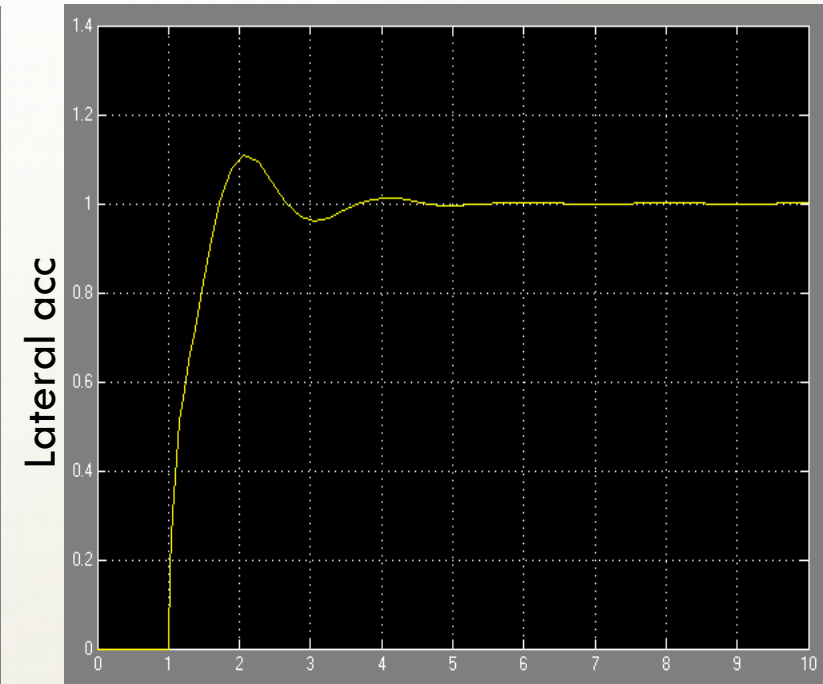

Time

$M=5000$ kg

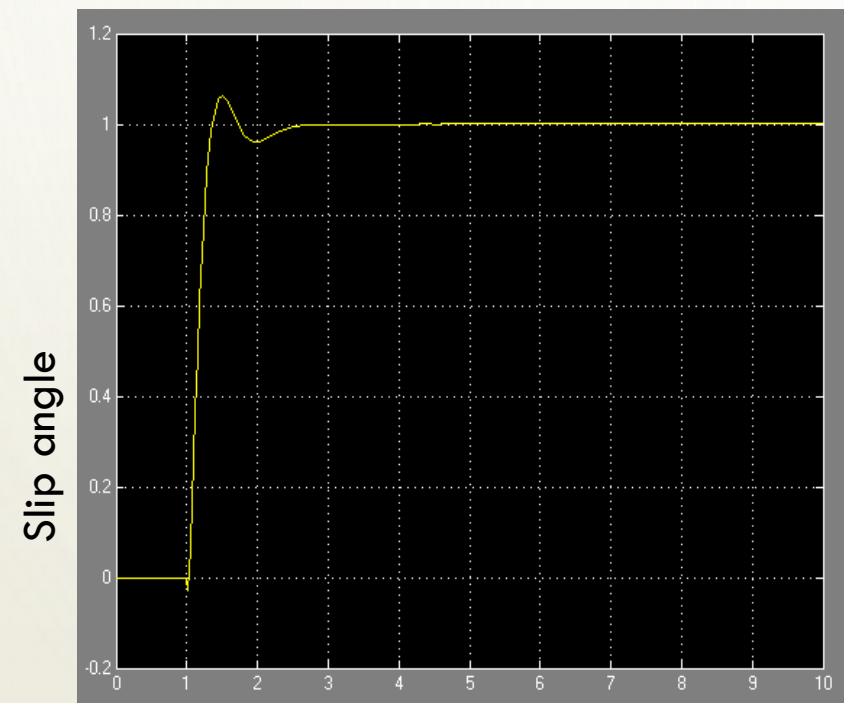

Time

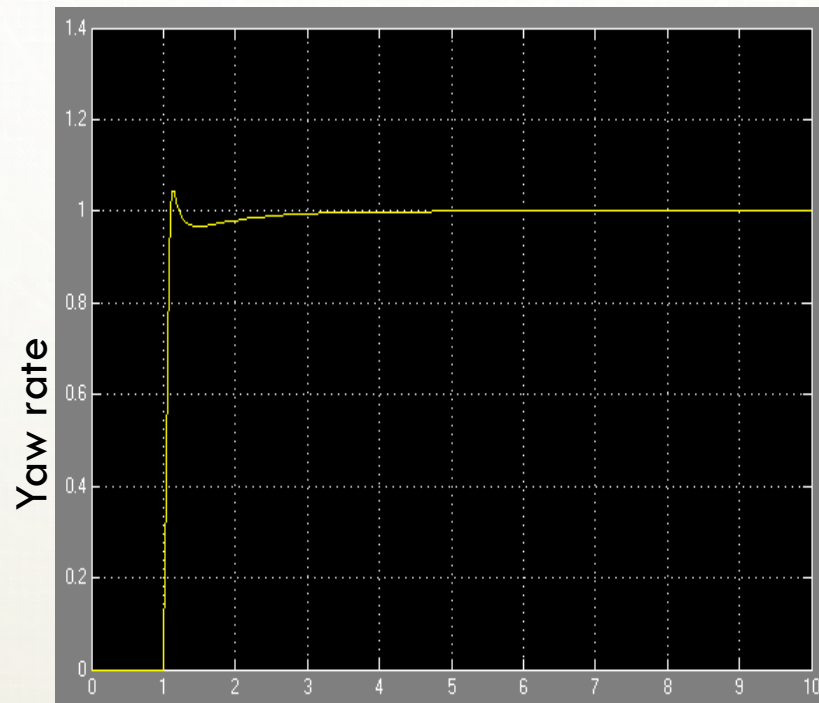

Time

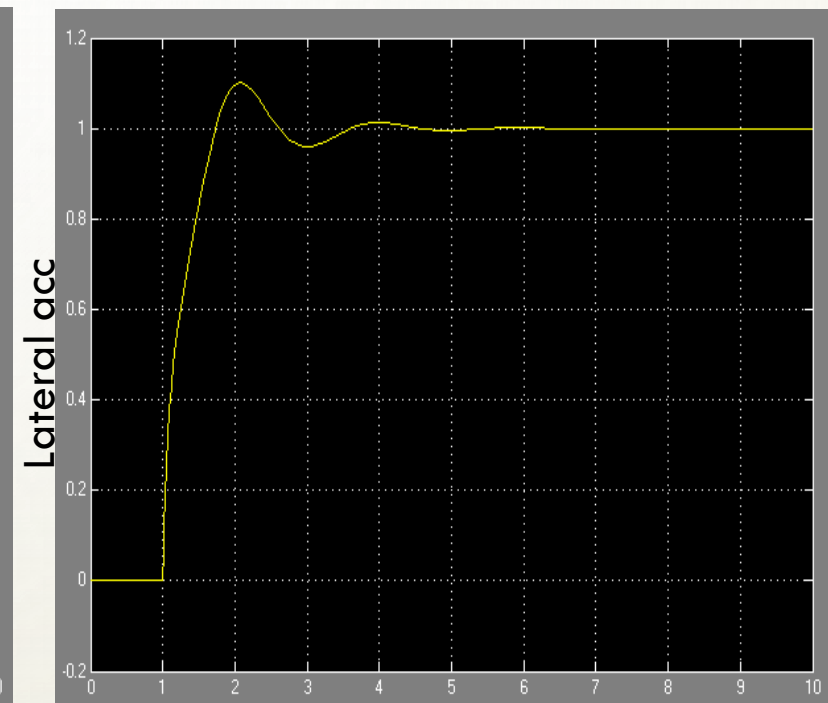

Time

RESULTS

Sl.No	Vehicle mass	Cornering Stiffness (kN/deg)		Settling Time (sec)	Peak
1.	1000	0.35	β	5.8	1.02
			Yaw rate	3.4	1.04
			Lateral acc.	10	No overshoot
2.	2000	0.65	β	4.4	1.04
			Yaw rate	4.3	1.05
			Lateral acc.	7.19	1.11
3.	3000	0.92	β	3.5	1.04
			Yaw rate	4.7	1.05
			Lateral acc.	6.2	1.09

RESULTS

Sl.No	Vehicle mass	Cornering Stiffness (kN/deg)		Settling Time (sec)	Peak
1.	4000	1.15	β	3.9	1.05
			Yaw rate	5.2	1.05
			Lateral acc.	6.2	1.11
2.	5000	1.22	β	4.2	1.06
			Yaw rate	5.7	1.06
			Lateral acc.	6.8	1.13
3.	6000	1.25	β	4.3	1.06
			Yaw rate	5.9	1.05
			Lateral acc.	6.9	1.13

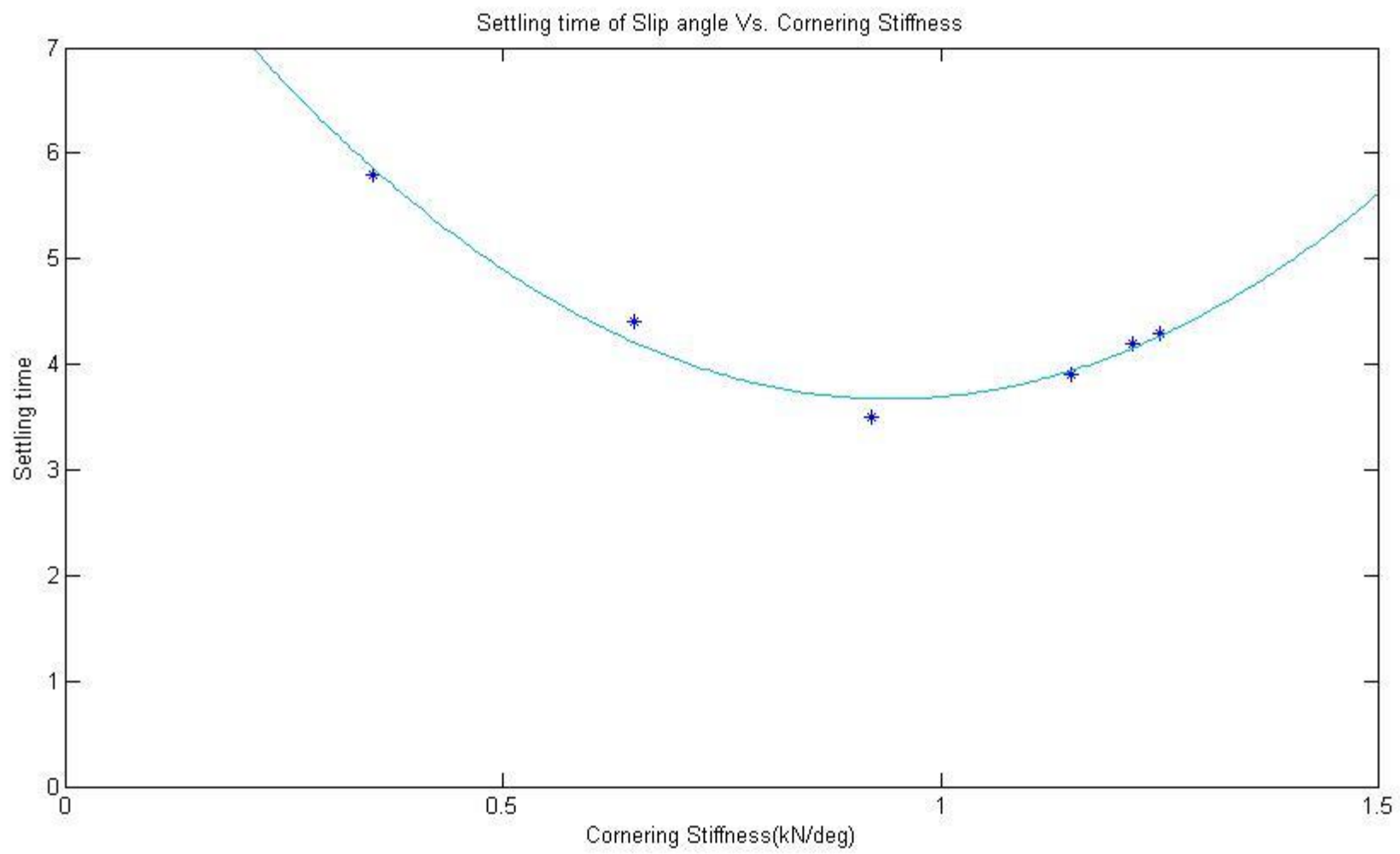

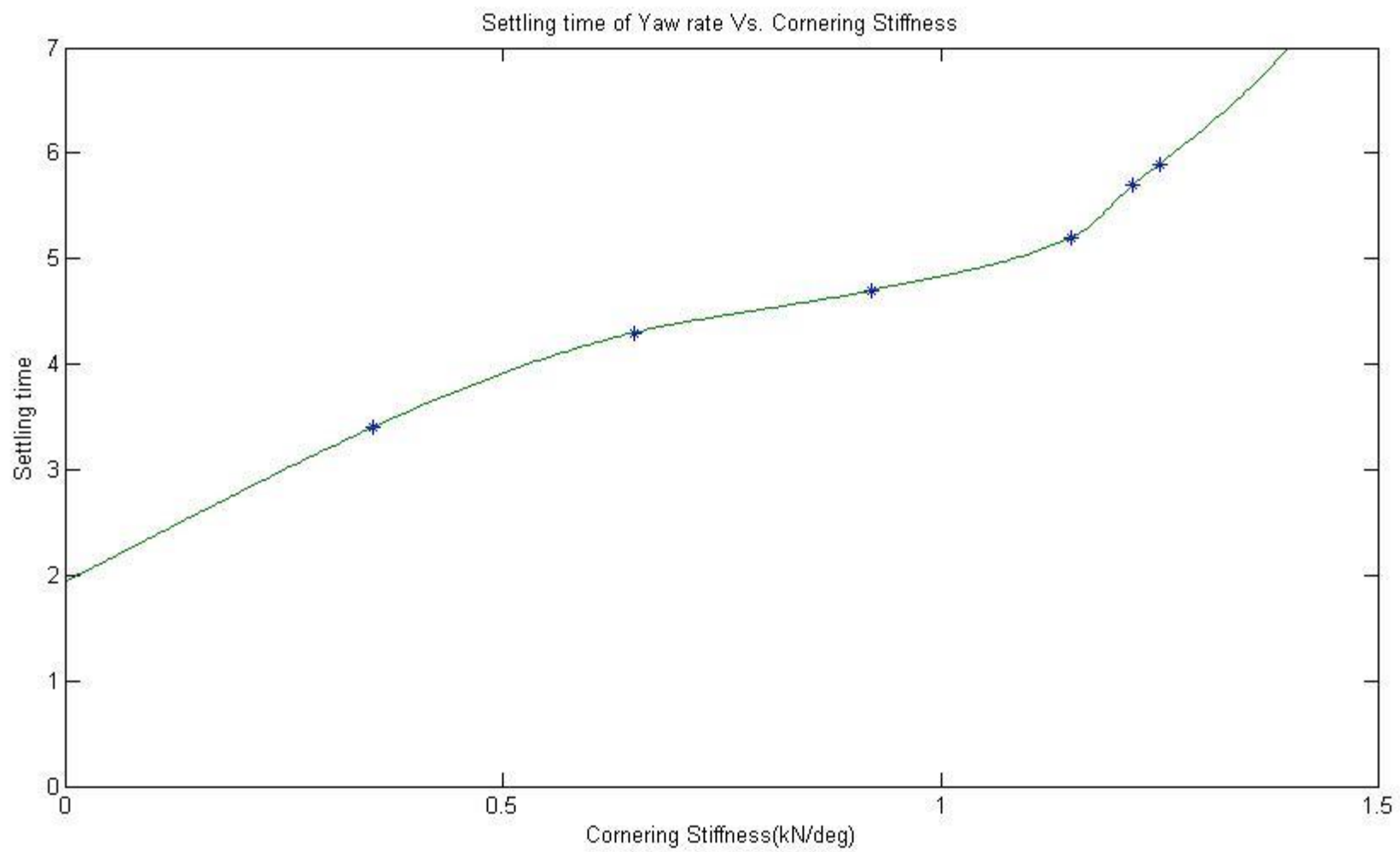

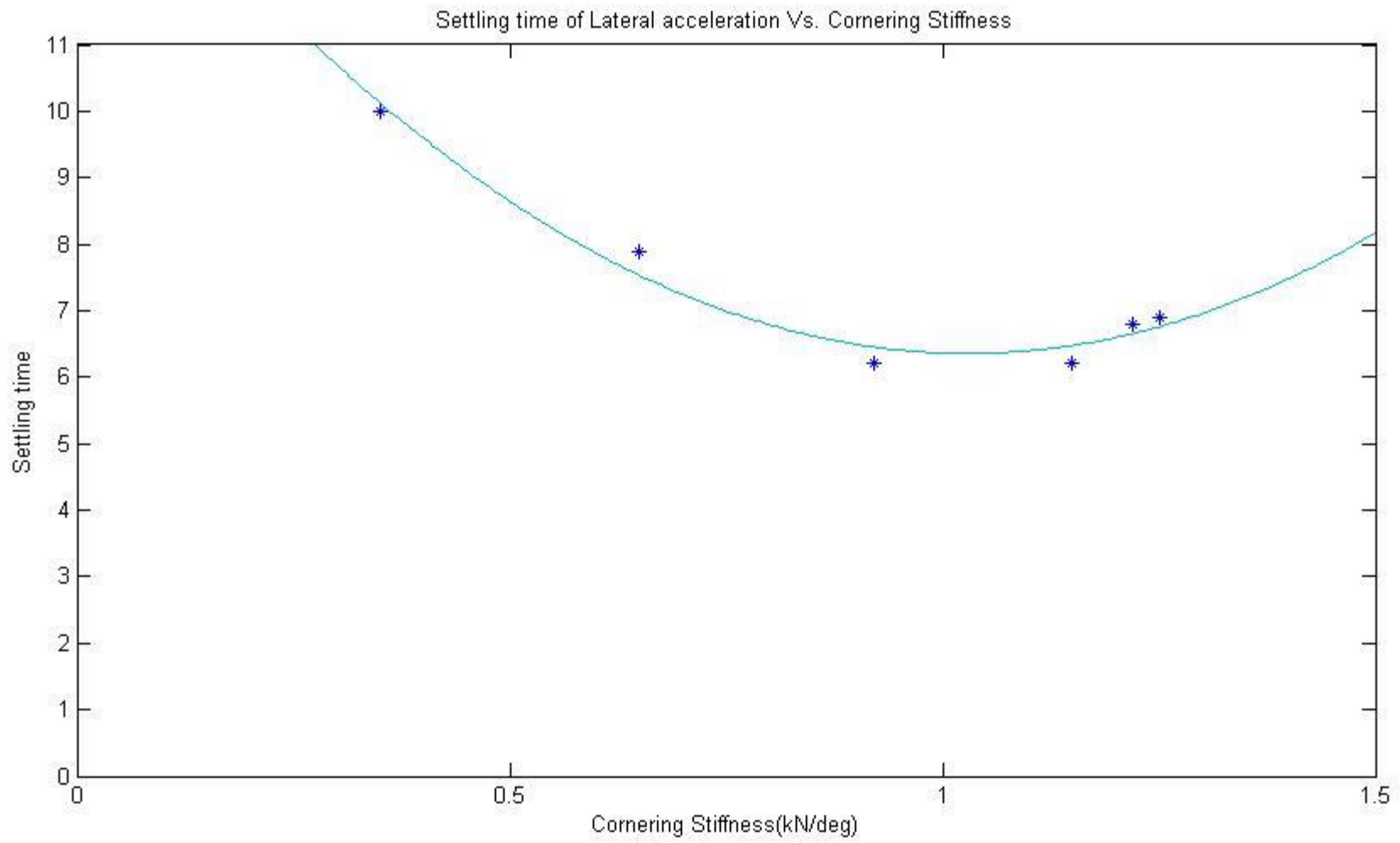

LATERAL CONTROL SYSTEM

- Control strategy: look-down reference system
 - Sensor at the front bumper to measure the lateral displacement
 - GPS to measure the heading orientation
- Firstly, the road curvature estimator is designed based on the steering angle, which has steering angle and its derivative as two state variables for which an estimation algorithm is employed whose input comes from the sensor and the GPS data
- The closed loop controller is used as a compensator to control the lateral dynamics
- Precise and real-time estimation of the lateral displacements w. R. T the road are accomplished using the proposed control system

SINGLE TRACK DYNAMICS

$$\dot{X} = AX + BU$$

$$X = \begin{bmatrix} d_{sf} \\ \dot{d}_{sf} \\ d_{sr} \\ \dot{d}_{sr} \end{bmatrix}, U = \begin{bmatrix} \delta_f \\ \rho_{ref} \end{bmatrix}, A = \begin{bmatrix} 0 & 1 & 0 & 0 \\ a_{21} & a_{22} & -a_{21} & a_{24} \\ 0 & 0 & 0 & 1 \\ a_{41} & a_{42} & -a_{41} & a_{44} \end{bmatrix}, B = \begin{bmatrix} 0 & 0 \\ b_{21} & -v^2 \\ 0 & g_4 v \\ b_{41} & -v^2 \end{bmatrix}$$

$$a_{21} = \frac{g_2}{Mg_4} - \frac{l_{sf}g_1}{I_\Psi g_4}, a_{22} = \frac{g_1 - l_{sr}g_2}{Mvg_4} + \frac{l_{sf}(l_{sr}g_1 - g_3)}{I_\Psi vg_4}, a_{24} = -\frac{g_1 + l_{sf}g_2}{Mvg_4} + \frac{l_{sf}(l_{sf}g_1 + g_3)}{I_\Psi vg_4}$$

$$a_{41} = \frac{g_2}{Mg_4} + \frac{l_{sr}g_1}{I_\Psi g_4}, a_{42} = \frac{g_1 - l_{sr}g_2}{Mvg_4} + \frac{l_{sr}(l_{sr}g_1 - g_3)}{I_\Psi vg_4}, a_{44} = -\frac{g_1 + l_{sf}g_2}{Mvg_4} - \frac{l_{sr}(l_{sf}g_1 + g_3)}{I_\Psi vg_4}$$

$$b_{21} = \mu c_f \left(\frac{1}{M} + \frac{l_{sf}l_{tf}}{I_\Psi} \right), b_{41} = \mu c_f \left(\frac{1}{M} - \frac{l_{sr}l_{tf}}{I_\Psi} \right)$$

$$g_1 = \mu(c_r l_{tr} - c_f l_{tf}), g_2 = \mu(c_f + c_r), g_3 = \mu(c_r l_{tr}^2 + c_f l_{tf}^2), g_4 = l_{sf} + l_{sr}$$

Actuator Dynamics

$$A(s) = \frac{80000}{(s + 62.8)(s + 12.56 + 28.77j)(s + 12.56 - 28.77j)}$$

Feedback Controller Dynamics

$$\text{Structure} = [C_f(s) \quad C_r(s)]$$

$$C_f(s) = \frac{K_{DDf}s^2 + K_{Df}s + K_{Pf}}{\left(\frac{s}{\omega_2} + 1\right)\left(\frac{s^2}{\omega_1^2} + \frac{2Ds}{\omega_1} + 1\right)} + \frac{K_I}{s}$$

$$C_r(s) = \frac{K_{DDr}s^2 + K_{Dr}s + K_{Pr}}{\left(\frac{s}{\omega_2} + 1\right)\left(\frac{s^2}{\omega_1^2} + \frac{2Ds}{\omega_1} + 1\right)}$$

CONTROL SYSTEM

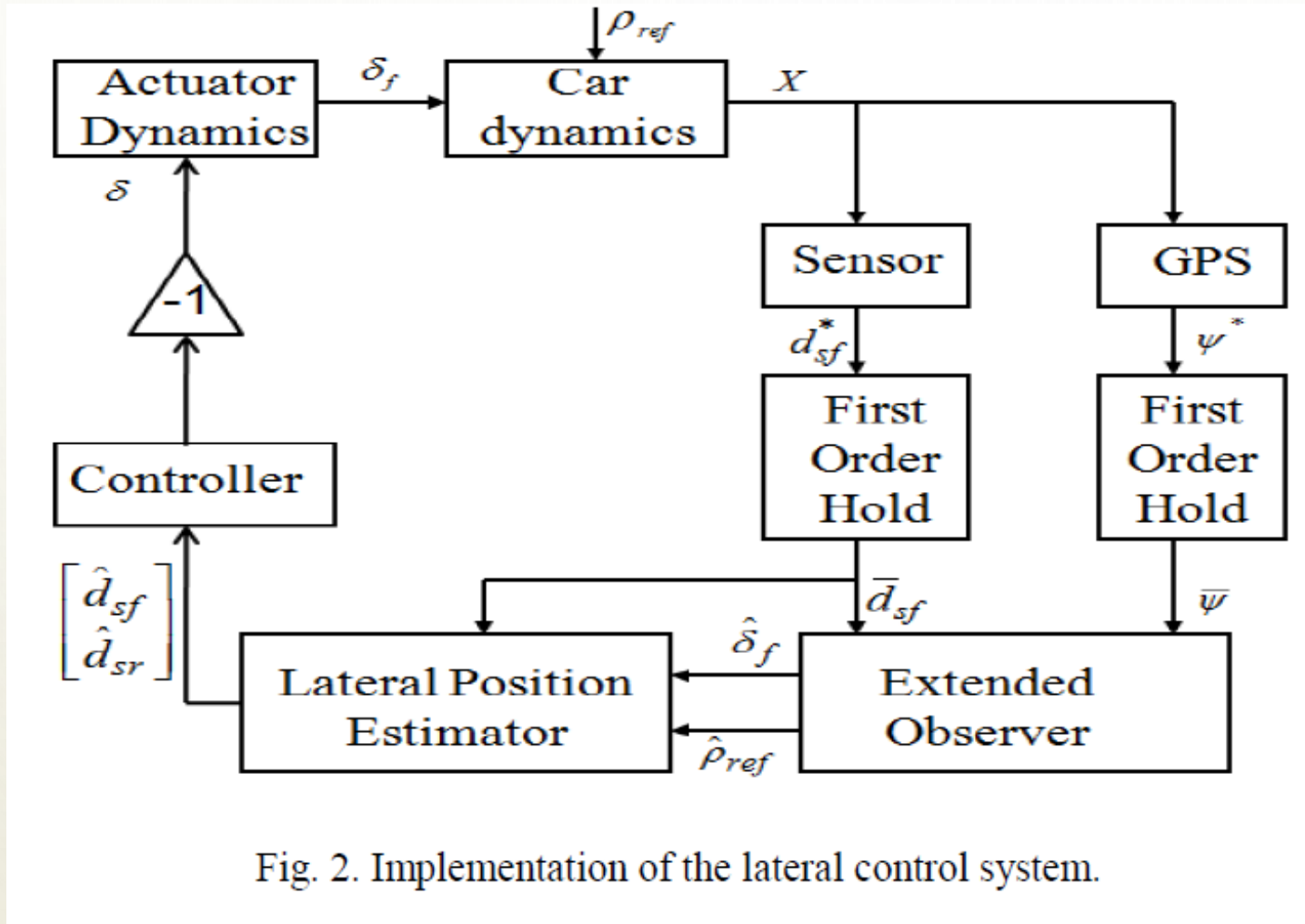

Fig. 2. Implementation of the lateral control system.

Implementation of Control System

Lateral Position Estimation System

$$\dot{\hat{X}} = A \hat{X} + BU + L(\bar{d}_{sr} - H \hat{X})$$

$$\hat{X} = \begin{bmatrix} \hat{d}_{sf} \\ \dot{\hat{d}}_{sf} \\ \hat{d}_{sr} \\ \dot{\hat{d}}_{sr} \end{bmatrix}$$

$$\hat{U} = \begin{bmatrix} \hat{\delta}_f \\ \hat{\rho}_{ref} \end{bmatrix}$$

$$X = l \begin{bmatrix} 1 \\ 1 \\ 1 \\ 1 \end{bmatrix}$$

RESULTS

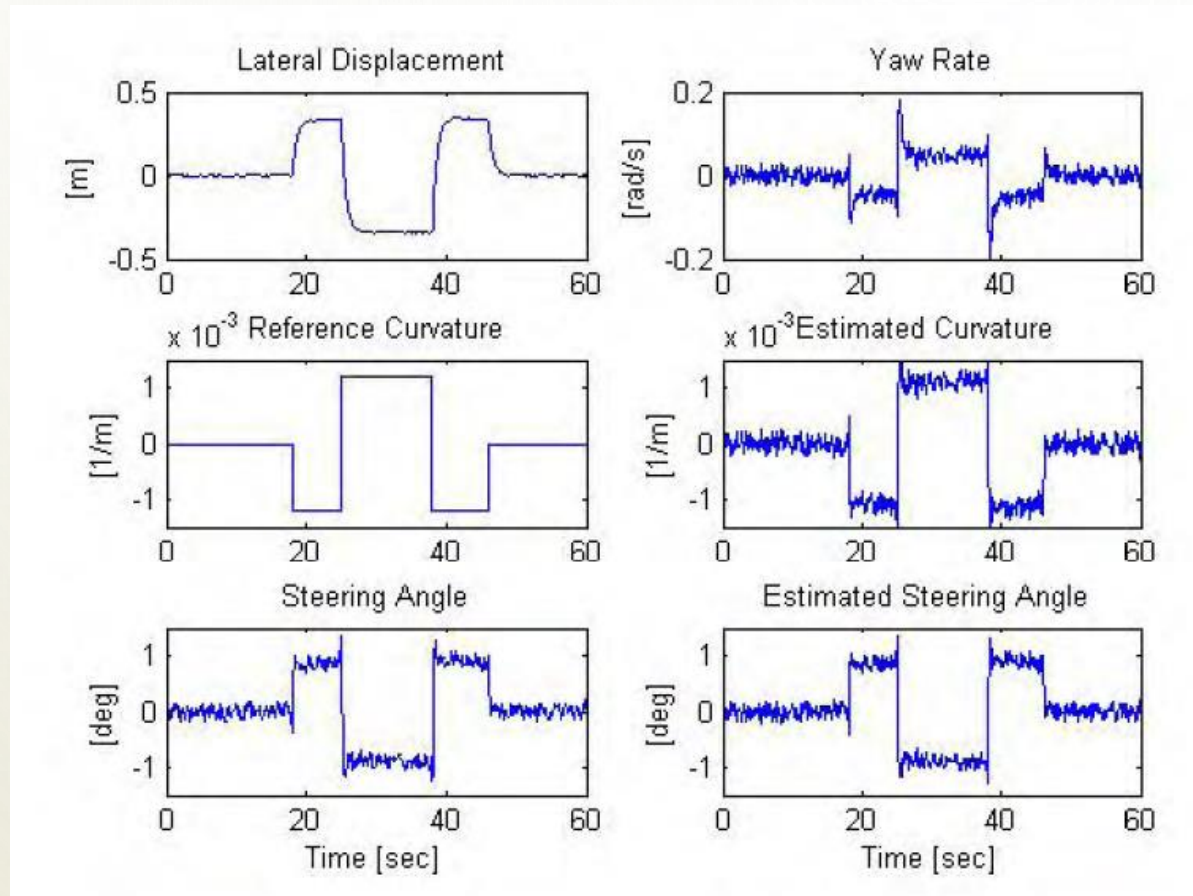

- The lateral displacement result has no overshoot and is well damped.
- The steering angle and road curvature estimations are within accuracy specifications.
- The estimation error of the steering angle is approximately 8% and the curvature estimation error is around 10%.

Simulation result for a speed 80mi/h on dry road (road adhesion factor of 1)

ELECTRIC POWER ASSISTED STEERING

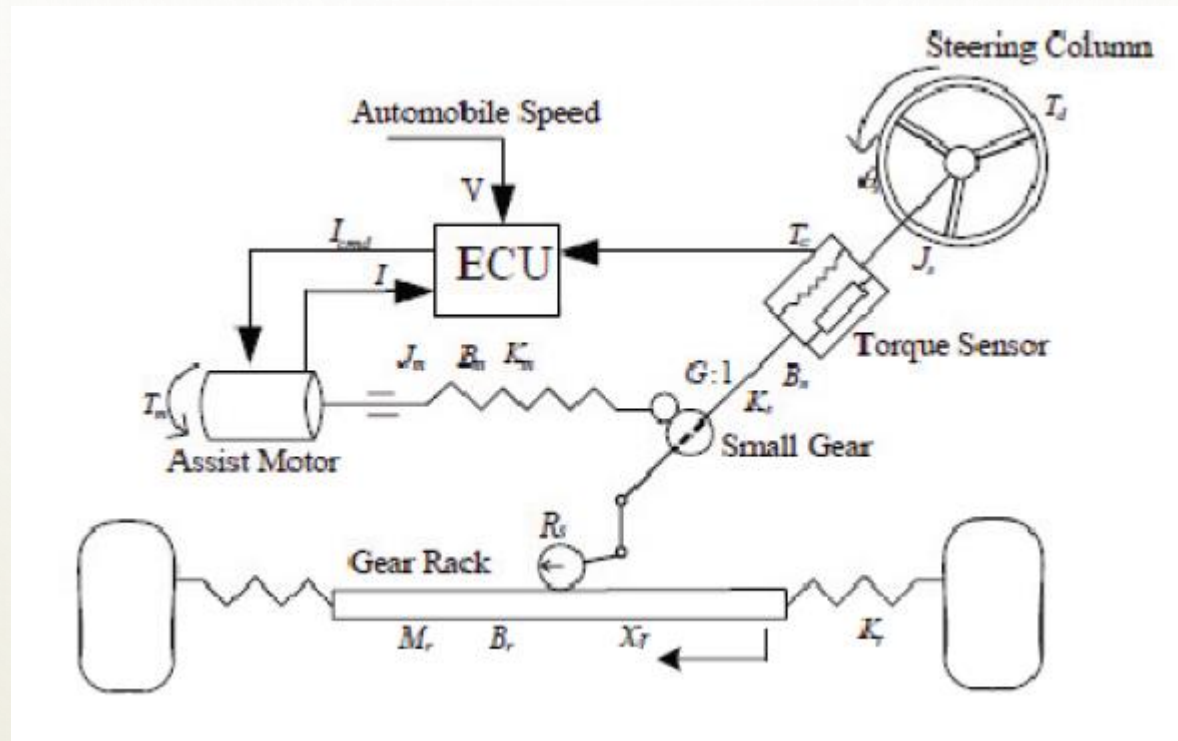

EQUATIONS

Steering column, Driver torque

$$J_s \ddot{\theta}_s + B_s \dot{\theta}_s + T_c = T_d$$

$$T_d = (\Delta\theta_s - \theta_s)(K_p + K_i \frac{1}{s} + K_d s)$$

$$T_c = K_s(\theta_s - \frac{x_r}{R_s})$$



Road conditions and friction

$$F_t = J_w \ddot{x}_r + B_w \dot{x}_r + K_w x_r$$



Assist Motor Model

$$J_m \ddot{\theta}_m + B_m \dot{\theta}_m = T_m - T_a$$

$$T_m = K_a i_a$$

$$T_a = GK_m (\theta_m - G \frac{x_r}{R_s})$$

$$I = i_a + K_w \theta_w$$



Rack and Pinion Displacement

$$M_r \ddot{x}_r + B_r \dot{x}_r - \frac{T_c}{R_s} = \frac{T_a}{R_s} - F_{TR}$$

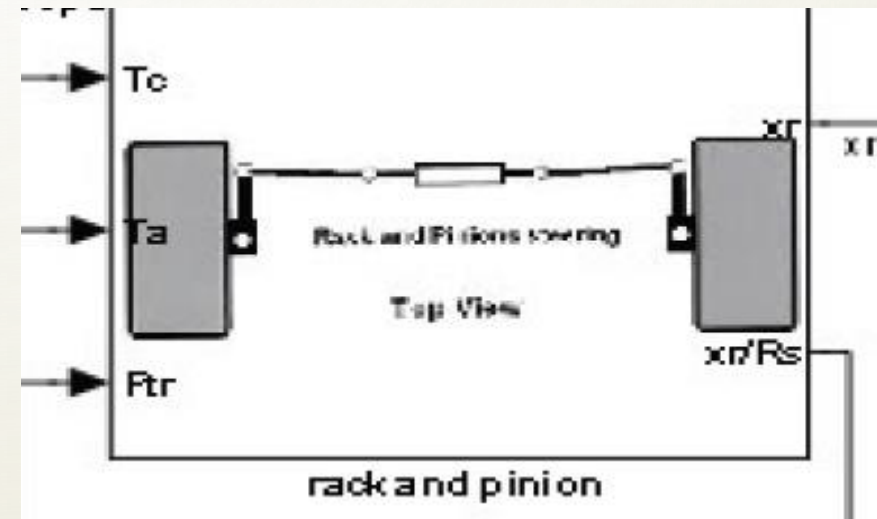

CONTROL DIAGRAM

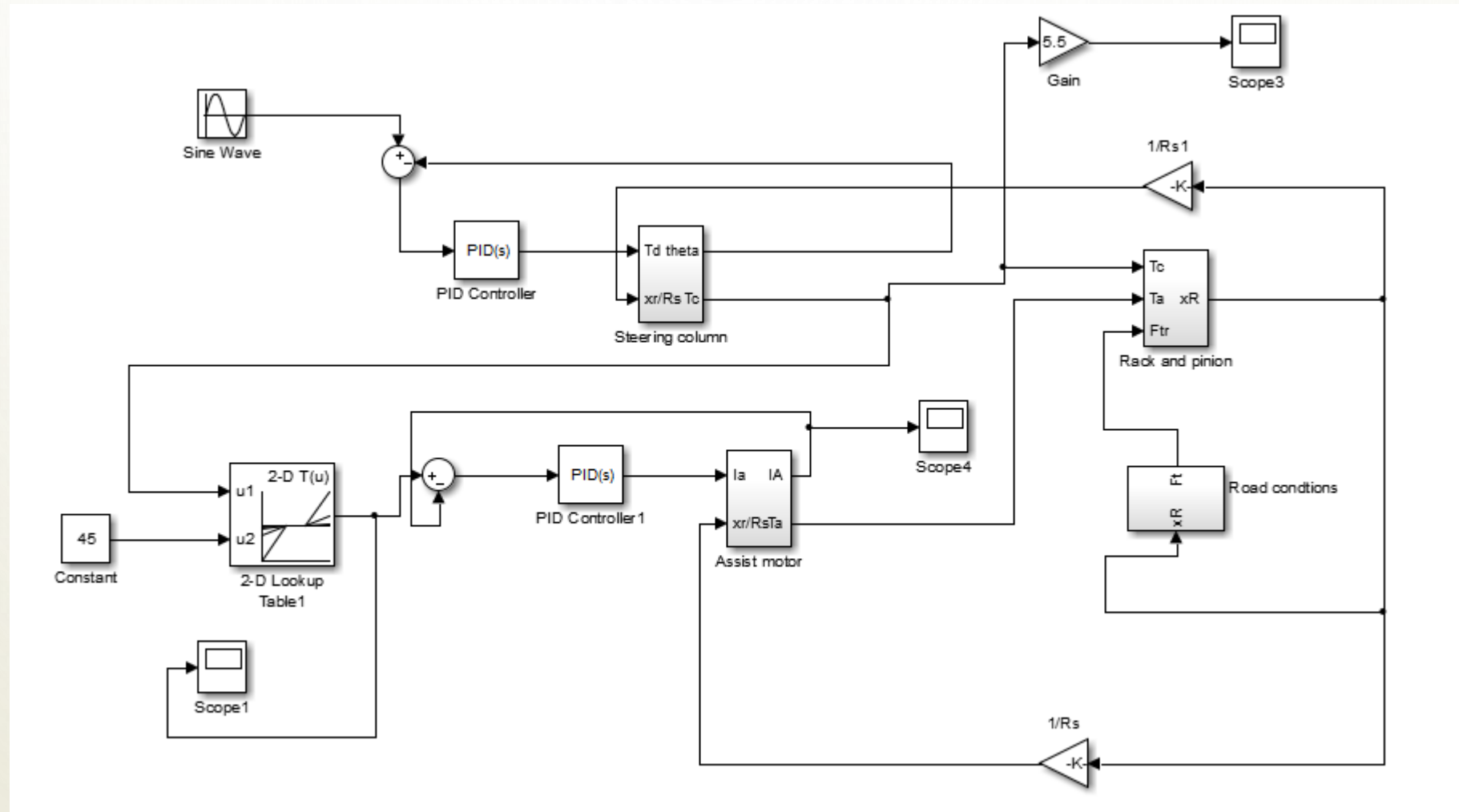

Speed 40kmph (without controller)

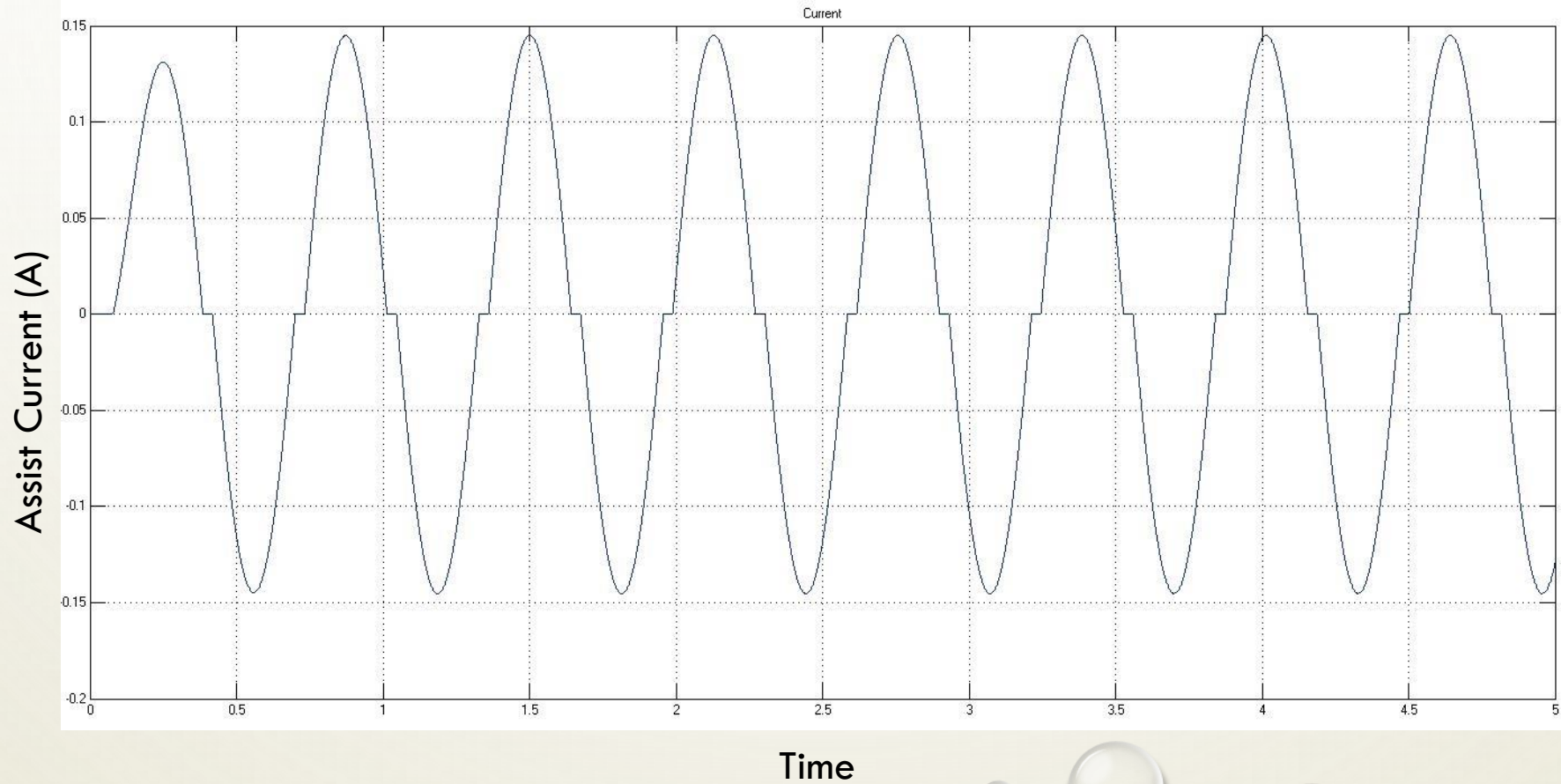

Speed 40kmph (with controller)

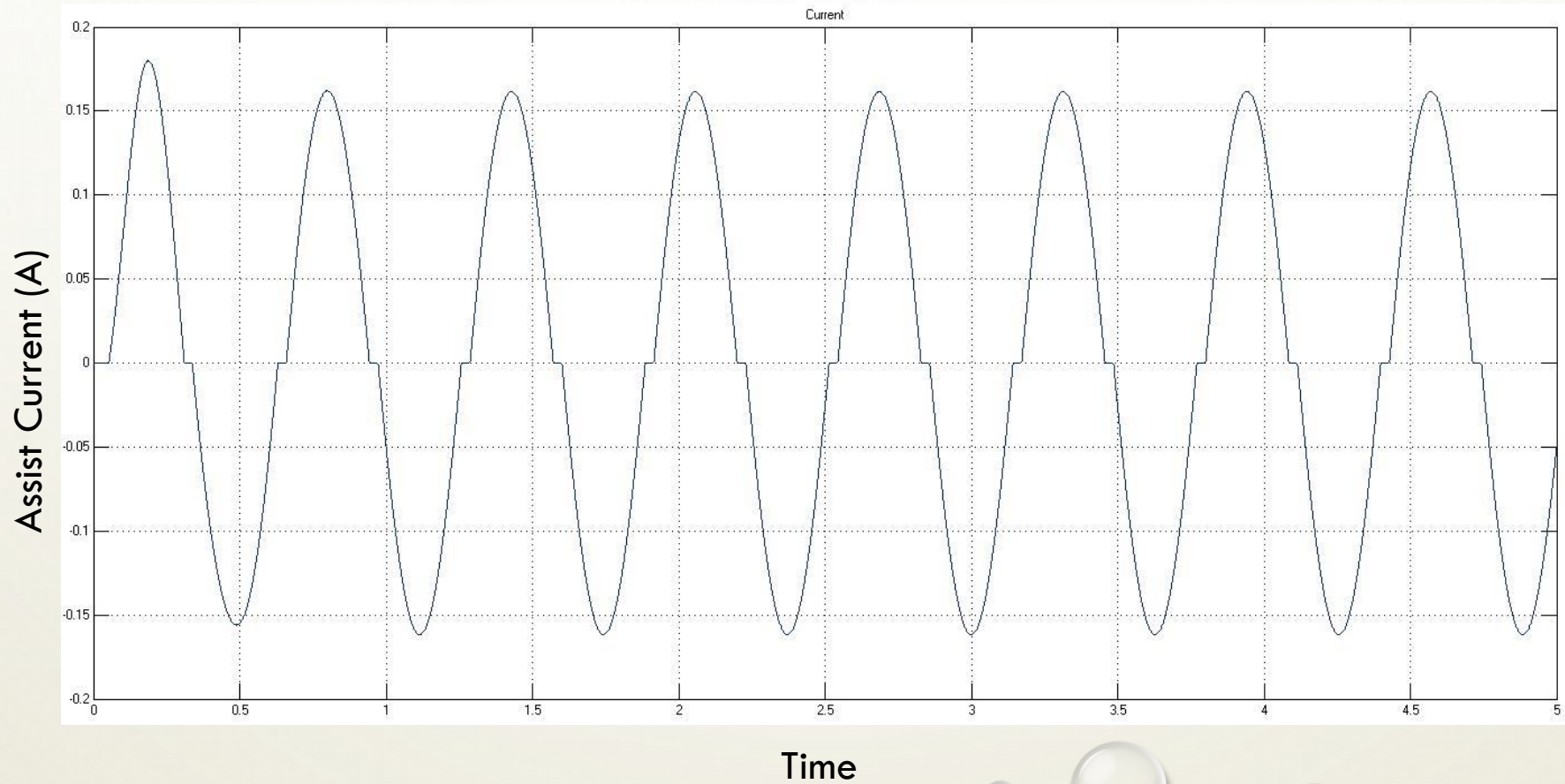

RESULTS

Sl.No	Vehicle Speed	Assist Current (without PID)	Assist Current (with PID)
1	40	0.16	0.14
2	50	0.24	0.19
3	60	0.28	0.24
4	70	0.33	0.29
5	80	0.38	0.34
6	90	0.62	0.55

The background features a light beige gradient with several realistic water droplets of varying sizes scattered around the edges. In the center, there is a faint, light-colored DNA double helix structure.

Genetic Algorithm

GA QUICK OVERVIEW

- Developed: USA in the 1970's
- Early names: J. Holland, K. Dejong, D. Goldberg
- Typically applied to:
 - Discrete optimization
- Attributed features:
 - Not too fast
 - Good heuristic for combinatorial problems
- Special features:
 - Traditionally emphasizes combining information from good parents (crossover)
 - Many variants, e.g., Reproduction models, operators

SIMPLE GENETIC ALGORITHM

produce an initial population of individuals

evaluate the fitness of all individuals

while termination condition not met **do**

 select fitter individuals for reproduction

 recombine between individuals

 mutate individuals

 evaluate the fitness of the modified individuals

 generate a new population

End while

1-POINT CROSSOVER

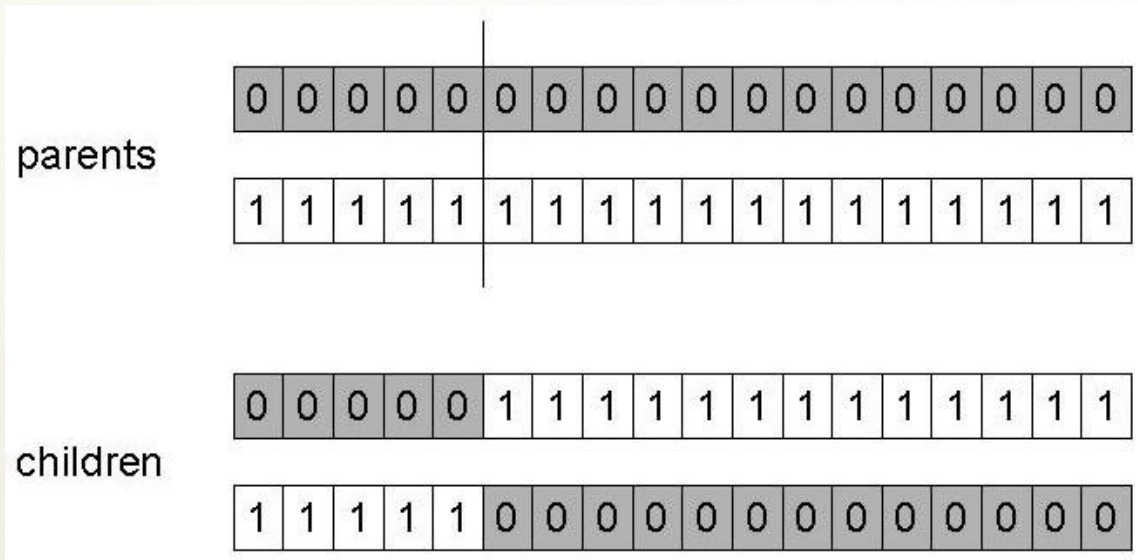

- Choose a random point on the two parents
- Split parents at this crossover point
- Create children by exchanging tails
- P_c typically in range (0.6, 0.9)

MUTATION

- Alter each gene independently with a probability p_m
- P_m is called the mutation rate
 - Typically between $1/\text{pop_size}$ and $1/\text{chromosome_length}$

parent

1	1	1	1	1	1	1	1	1	1	1	1	1	1	1	1	1	1
---	---	---	---	---	---	---	---	---	---	---	---	---	---	---	---	---	---

child

0	1	0	0	1	0	1	1	0	0	0	1	0	1	1	0	0	1
---	---	---	---	---	---	---	---	---	---	---	---	---	---	---	---	---	---

RESULTS

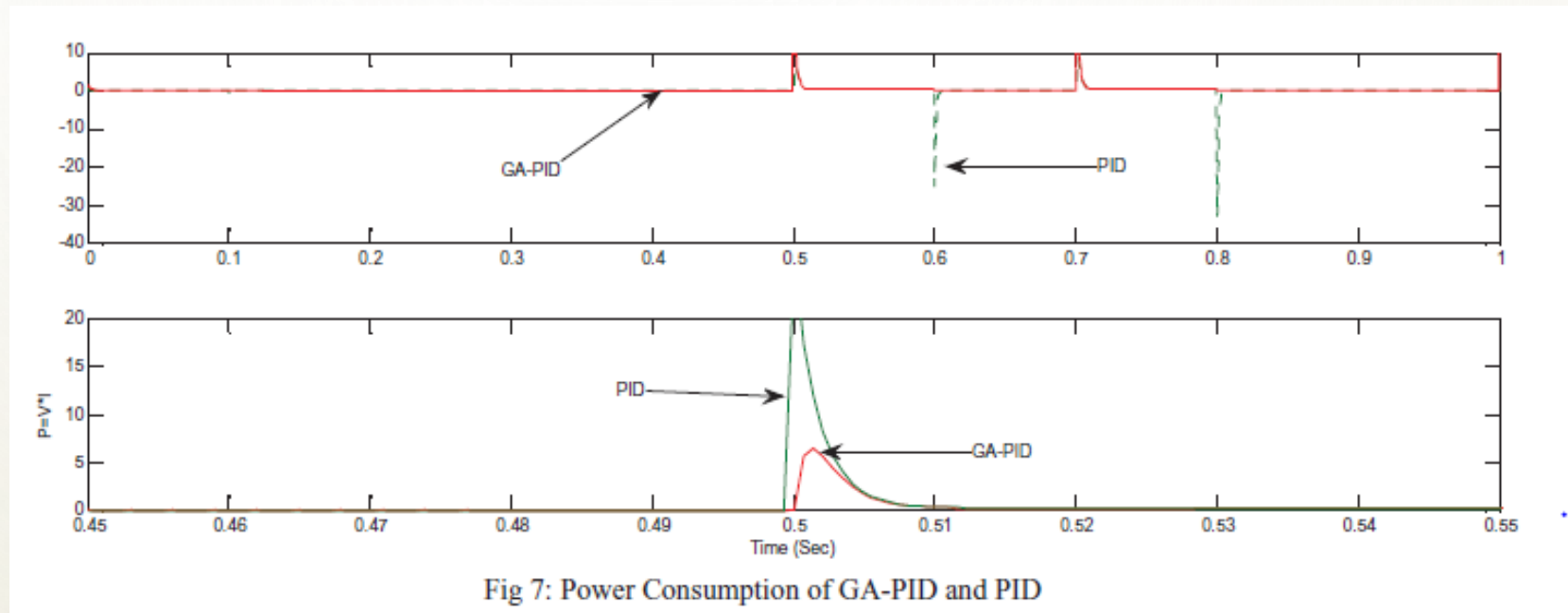

STABILITY ANALYSIS

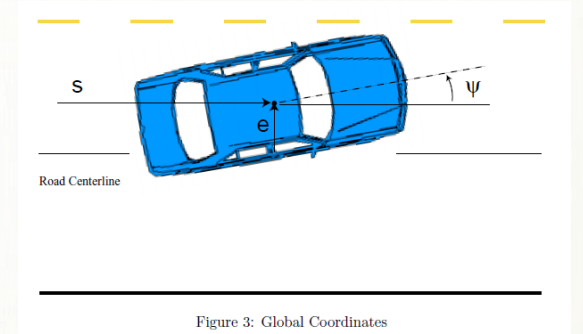

- The vehicle model used in the analysis is a simple three degree of freedom yaw plane representation with differential braking

$$m\dot{U}_x = F_{xr} + F_{xf}\cos\lambda - F_{yf}\sin\lambda + mrU_y$$

$$m\dot{U}_y = F_{yr} + F_{xf}\sin\lambda + F_{yf}\cos\lambda - mrU_x$$

$$I_z\dot{r} = aF_{xf}\sin\delta + aF_{yf}\cos\delta - bF_{yr} + \frac{d}{2}(\Delta F_{xr} + \Delta F_{xf}\cos\lambda)$$

VEHICLE MODEL

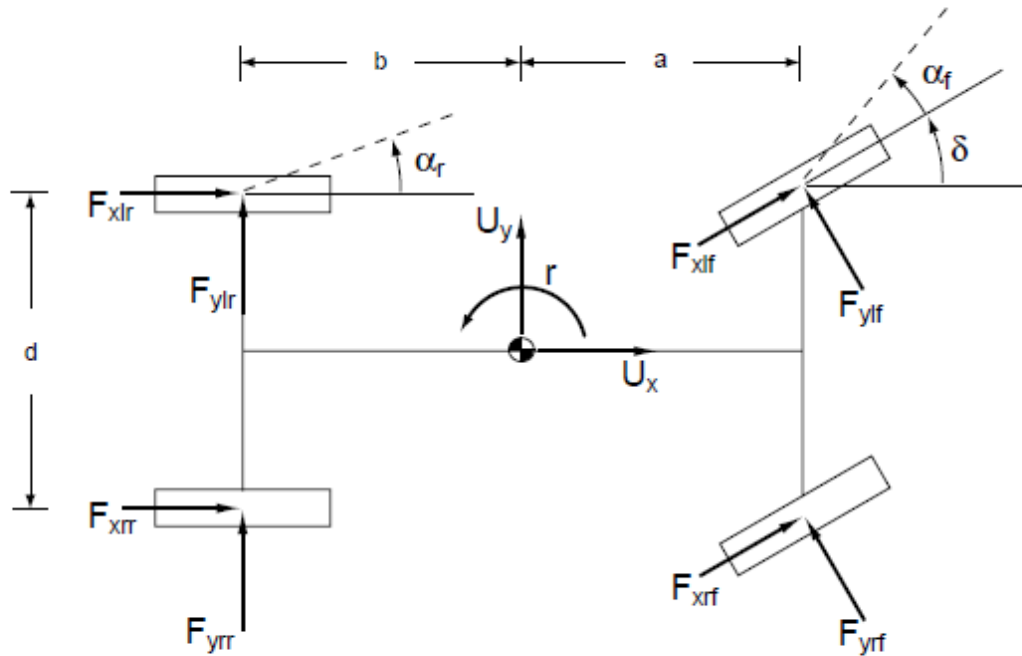

Figure 1: Vehicle Model

$$\begin{aligned} F_{xf} &= F_{xrf} + F_{xlf} \\ F_{xr} &= F_{xrr} + F_{xlr} \\ \Delta F_{xf} &= F_{xrf} - F_{xlf} \\ \Delta F_{xr} &= F_{xrr} - F_{xlr} \end{aligned}$$

EQUATIONS INVOLVED

- Assuming small angles and equal slip angles on the left and right wheels,

$$\alpha_{fr} = \frac{U_y + ra}{U_x} - \delta$$

$$\alpha_r = \frac{U_y - rb}{U_x}$$

- Using a linear tire model, the lateral forces are given as

$$F_{yf} = -C_f \alpha_f$$

$$F_{yr} = -C_r \alpha_r$$

EQUATIONS INVOLVED

- Where C_f and C_r are the front and rear cornering stiffness's, respectively. Substituting the expressions or the lateral forces into equations 1 through 3 and making small angle approximations yields,

- $$m\dot{U}_x = mrU_y + F_{xr} + F_{xf} + C_f \frac{(U_y+ra)}{U_x} \delta$$

- $$m\dot{U}_y = -C_r \frac{(U_y-rb)}{U_x} - C_f \frac{(U_y+ra)}{U_x} - mrU_x + C_f \delta + F_{xf} \delta$$

- $$I_z \dot{r} = aF_{xf} \delta - aC_f \frac{(U_y+ra)}{U_x} + bC_r \frac{(U_y-rb)}{U_x} + aC_f \delta + \frac{d}{2} (\Delta F_{xr} + \Delta F_{xf})$$

EQUATIONS INVOLVED

- The linearization of a vehicle about a constant longitudinal velocity gives,

$$\dot{\delta x} = A \delta x$$

where $\delta x = \begin{bmatrix} \delta e \\ \delta \dot{e} \\ \delta \psi \\ \delta \dot{\psi} \end{bmatrix}$

$$A = \begin{bmatrix} 0 & 1 & 0 & 0 \\ 0 & \frac{-(C_f + Cr)}{mS} & \frac{(C_f + Cr)}{m} & \frac{(-aC_f + bCr)}{mS} \\ 0 & 0 & 0 & 1 \\ 0 & \frac{(-aC_f + bCr)}{I_z S} & \frac{(aC_f - bCr)}{I_z} & \frac{-(a^2 C_f + b^2 Cr)}{I_z S} \end{bmatrix}$$

STABILITY ANALYSIS

- Taking the determinant of $(\lambda I - A)$ yields the characteristic equation of the system

$$\lambda^2(\lambda^2 + \lambda a_1 + a_2) = 0$$

$$a_1 = \frac{(C_f + Cr)I_z + (a^2 C_f + b^2 C_r)m}{I_z m S}$$

$$a_2 = \frac{C_f Cr(a+b)^2 + (bC_r - aC_f)mS^2}{I_z m S^2}$$

STABLE AND UNSTABLE REGIONS VARYING CORNERING STIFFNESS

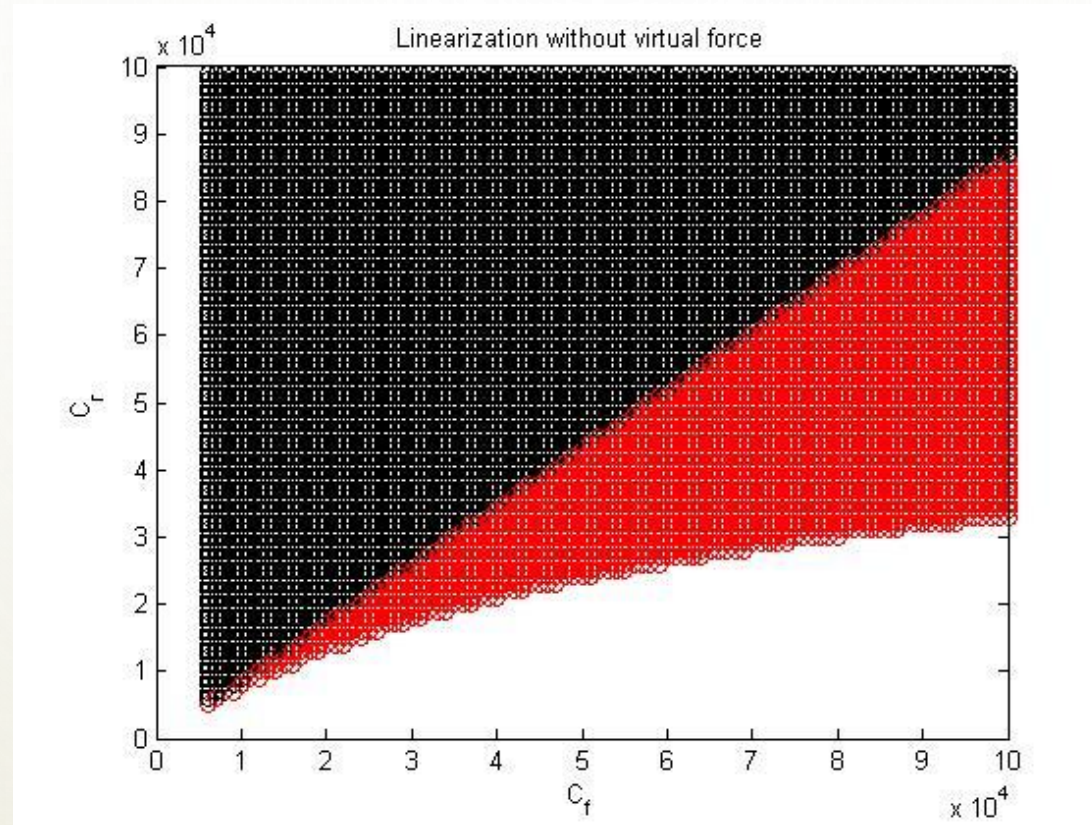

- Stable oversteer region
- Stable understeer region

LINEARIZATION WITHOUT VIRTUAL FORCE

- In an oversteering case ($aC_f > bC_r$), the coefficient α_2 will be negative when the speed

- The critical speed obtained
$$S > \sqrt{\frac{C_f C_r (a+b)^2}{(aC_f - bC_r)m}}$$

