

CHAPTER

16

VECTOR MECHANICS FOR ENGINEERS:
DYNAMICS

Ferdinand P. Beer
E. Russell Johnston, Jr.

Lecture Notes:
J. Walt Oler
Texas Tech University

Plane Motion of Rigid Bodies:
Forces and Accelerations

Vector Mechanics for Engineers: Dynamics

Contents

[Introduction](#)

[Equations of Motion of a Rigid Body](#)

[Angular Momentum of a Rigid Body in
Plane Motion](#)

[Plane Motion of a Rigid Body:
d'Alembert's Principle](#)

[Axioms of the Mechanics of Rigid
Bodies](#)

[Problems Involving the Motion of a
Rigid Body](#)

[Sample Problem 16.1](#)

[Sample Problem 16.2](#)

[Sample Problem 16.3](#)

[Sample Problem 16.4](#)

[Sample Problem 16.5](#)

[Constrained Plane Motion](#)

[Constrained Plane Motion:
Noncentroidal Rotation](#)

[Constrained Plane Motion:
Rolling Motion](#)

[Sample Problem 16.6](#)

[Sample Problem 16.8](#)

[Sample Problem 16.9](#)

[Sample Problem 16.10](#)

Introduction

- In this chapter and in Chapters 17 and 18, we will be concerned with the *kinetics* of rigid bodies, i.e., relations between the forces acting on a rigid body, the shape and mass of the body, and the motion produced.
- Results of this chapter will be restricted to:
 - plane motion of rigid bodies, and
 - rigid bodies consisting of plane slabs or bodies which are symmetrical with respect to the reference plane.

- Our approach will be to consider rigid bodies as made of large numbers of particles and to use the results of Chapter 14 for the motion of systems of particles. Specifically,

$$\sum \vec{F} = m\vec{a} \quad \text{and} \quad \sum \vec{M}_G = \dot{\vec{H}}_G$$

- D'Alembert's principle is applied to prove that the external forces acting on a rigid body are equivalent a vector $m\vec{a}$ attached to the mass center and a couple of moment $\bar{I}\alpha$.

Vector Mechanics for Engineers: Dynamics

Equations of Motion for a Rigid Body

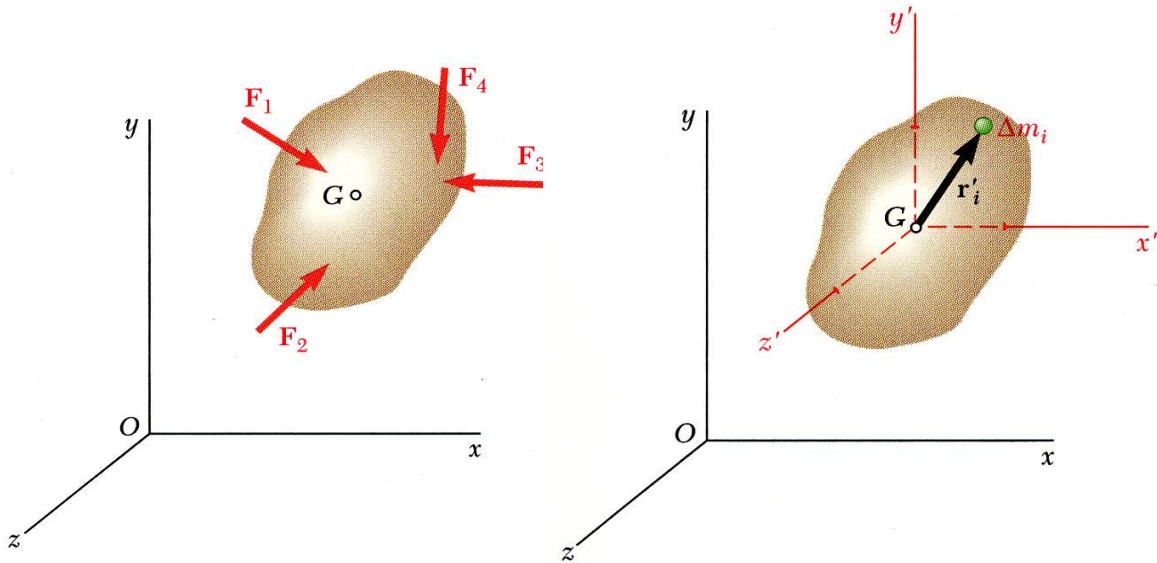

- Consider a rigid body acted upon by several external forces.
- Assume that the body is made of a large number of particles.
- For the motion of the mass center G of the body with respect to the Newtonian frame $Oxyz$,

$$\sum \vec{F} = m\vec{a}$$

- For the motion of the body with respect to the centroidal frame $Gx'y'z'$,

$$\sum \vec{M}_G = \dot{\vec{H}}_G$$

- System of external forces is equipollent to the system consisting of $m\vec{a}$ and $\dot{\vec{H}}_G$.

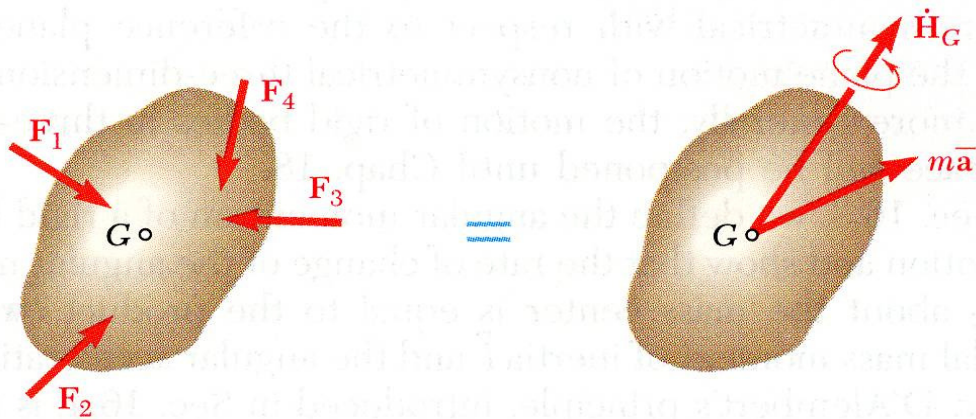

Vector Mechanics for Engineers: Dynamics

Angular Momentum of a Rigid Body in Plane Motion

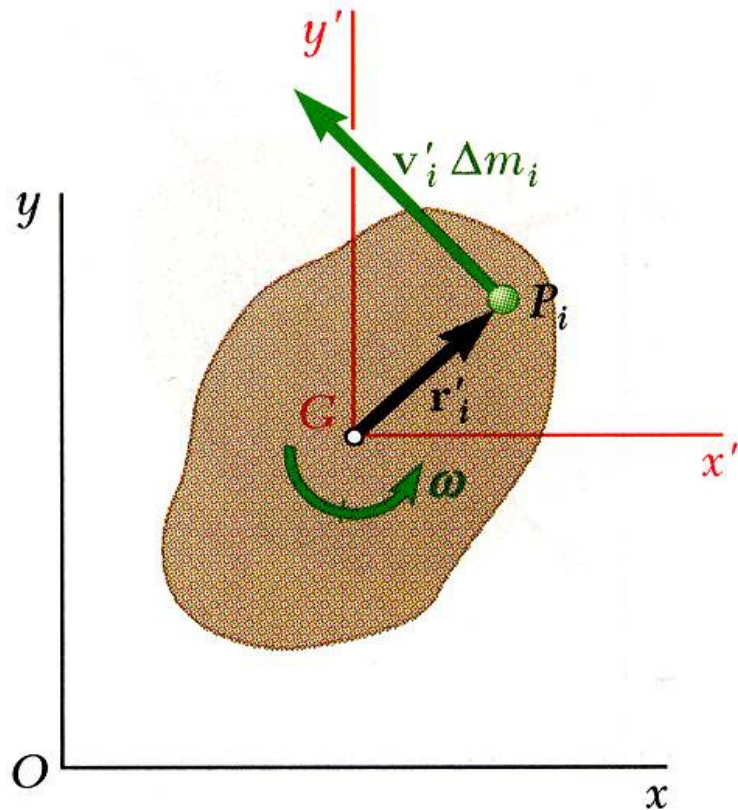

- Consider a rigid slab in plane motion.

- Angular momentum of the slab may be computed by

$$\begin{aligned}\vec{H}_G &= \sum_{i=1}^n (\vec{r}'_i \times \vec{v}'_i \Delta m_i) \\ &= \sum_{i=1}^n [\vec{r}'_i \times (\vec{\omega} \times \vec{r}'_i) \Delta m_i] \\ &= \vec{\omega} \sum (r_i'^2 \Delta m_i) \\ &= \bar{I} \vec{\omega}\end{aligned}$$

- After differentiation,

$$\dot{\vec{H}}_G = \bar{I} \dot{\vec{\omega}} = \bar{I} \vec{\alpha}$$

- Results are also valid for plane motion of bodies which are symmetrical with respect to the reference plane.
- Results are not valid for asymmetrical bodies or three-dimensional motion.

Vector Mechanics for Engineers: Dynamics

Plane Motion of a Rigid Body: D'Alembert's Principle

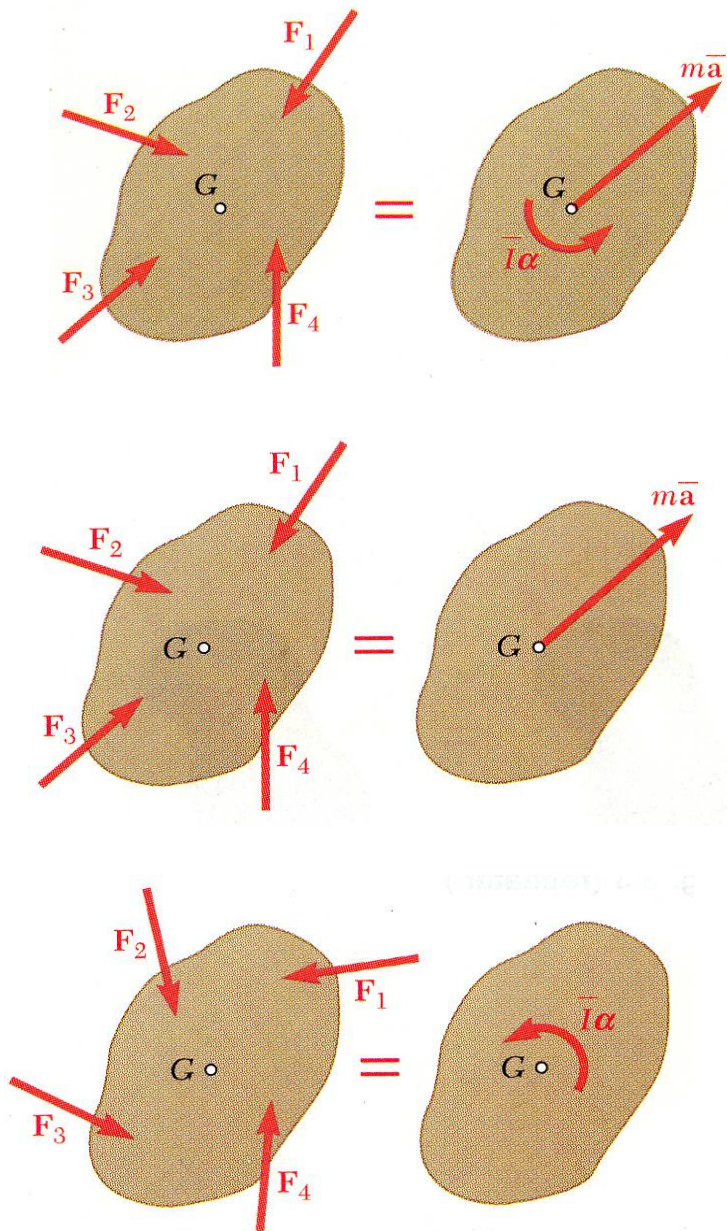

- Motion of a rigid body in plane motion is completely defined by the resultant and moment resultant about G of the external forces.

$$\sum F_x = m\bar{a}_x \quad \sum F_y = m\bar{a}_y \quad \sum M_G = I\bar{\alpha}$$

- The external forces and the collective effective forces of the slab particles are *equipollent* (reduce to the same resultant and moment resultant) and *equivalent* (have the same effect on the body).
- *d'Alembert's Principle*: The external forces acting on a rigid body are equivalent to the effective forces of the various particles forming the body.
- The most general motion of a rigid body that is symmetrical with respect to the reference plane can be replaced by the sum of a translation and a centroidal rotation.

Vector Mechanics for Engineers: Dynamics

Axioms of the Mechanics of Rigid Bodies

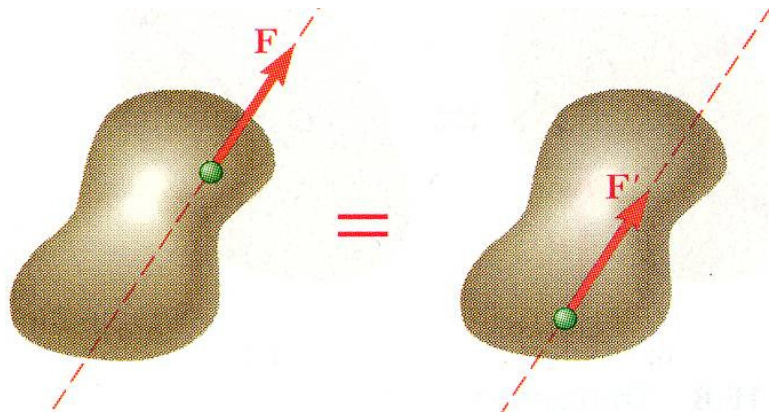

- The forces \vec{F} and \vec{F}' act at different points on a rigid body but but have the same magnitude, direction, and line of action.
- The forces produce the same moment about any point and are therefore, equipollent external forces.
- This proves the principle of transmissibility whereas it was previously stated as an axiom.



Vector Mechanics for Engineers: Dynamics

Problems Involving the Motion of a Rigid Body

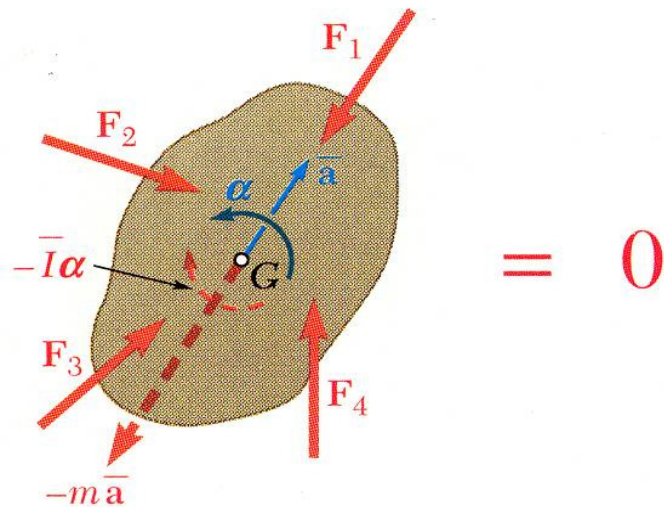
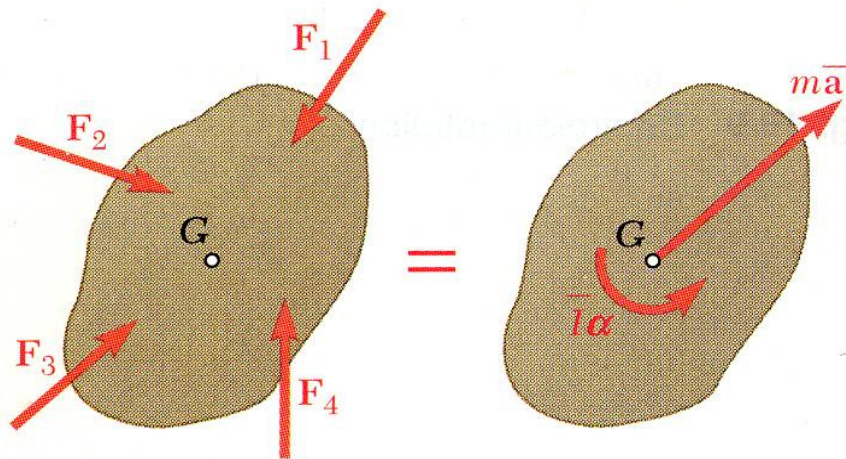

- The fundamental relation between the forces acting on a rigid body in plane motion and the acceleration of its mass center and the angular acceleration of the body is illustrated in a free-body-diagram equation.
- The techniques for solving problems of static equilibrium may be applied to solve problems of plane motion by utilizing
 - d'Alembert's principle, or
 - principle of dynamic equilibrium
- These techniques may also be applied to problems involving plane motion of connected rigid bodies by drawing a free-body-diagram equation for each body and solving the corresponding equations of motion simultaneously.

Vector Mechanics for Engineers: Dynamics

Sample Problem 16.1

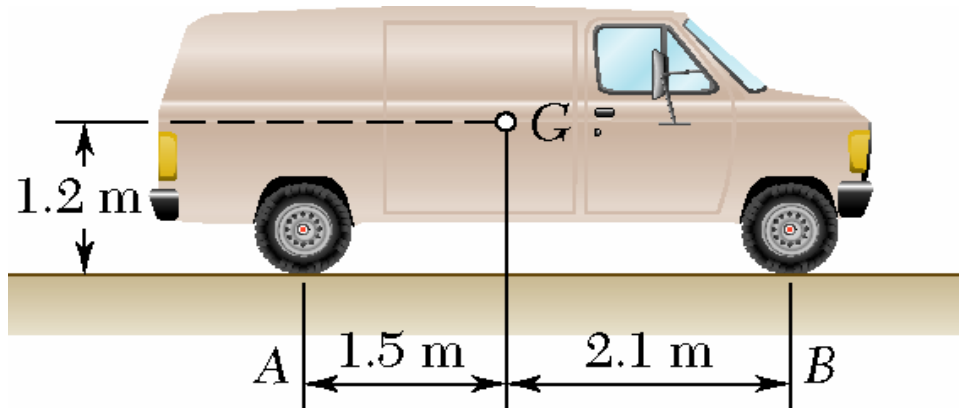

At a forward speed of 10 m/s, the truck brakes were applied, causing the wheels to stop rotating. It was observed that the truck skidded to a stop in 6 m.

Determine the magnitude of the normal reaction and the friction force at each wheel as the truck skidded to a stop.

SOLUTION:

- Calculate the acceleration during the skidding stop by assuming uniform acceleration.
- Draw the free-body-diagram equation expressing the equivalence of the external and effective forces.
- Apply the three corresponding scalar equations to solve for the unknown normal wheel forces at the front and rear and the coefficient of friction between the wheels and road surface.

Vector Mechanics for Engineers: Dynamics

Sample Problem 16.1

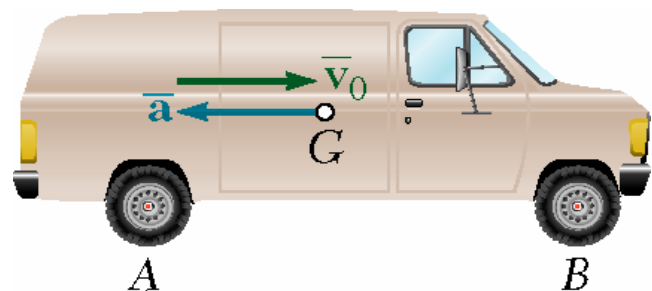

$$\bar{v}_0 = 10 \text{ m/s} \quad \bar{x} = 6 \text{ m}$$

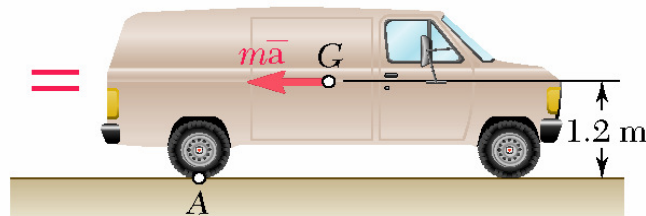
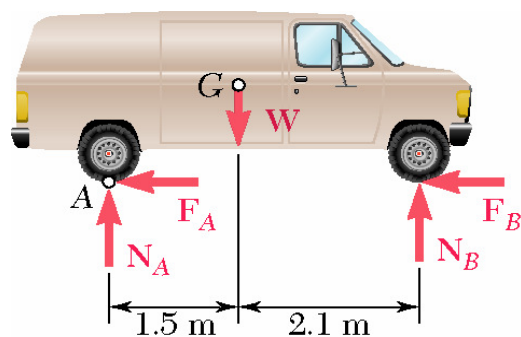

SOLUTION:

- Calculate the acceleration during the skidding stop by assuming uniform acceleration.

$$\bar{v}^2 = \bar{v}_0^2 + 2\bar{a}(\bar{x} - \bar{x}_0)$$

$$0 = (10 \text{ m/s})^2 + 2\bar{a}(6 \text{ m}) \quad \bar{a} = -8.33 \text{ m/s}^2$$

- Draw a free-body-diagram equation expressing the equivalence of the external and effective forces.
- Apply the corresponding scalar equations.

$$+\uparrow \sum F_y = \sum (F_y)_{eff} \quad N_A + N_B - W = 0$$

$$+\rightarrow \sum F_x = \sum (F_x)_{eff} \quad -F_A - F_B = -m\bar{a}$$

$$-\mu_k(N_A + N_B) =$$

$$-\mu_k W = -(W/g)\bar{a}$$

$$\mu_k = \frac{\bar{a}}{g} = \frac{8.33}{9.81} = 0.849$$

Vector Mechanics for Engineers: Dynamics

Sample Problem 16.1

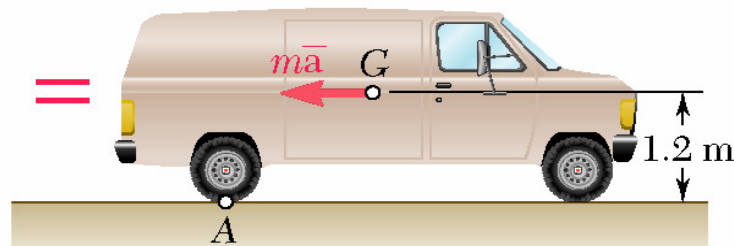
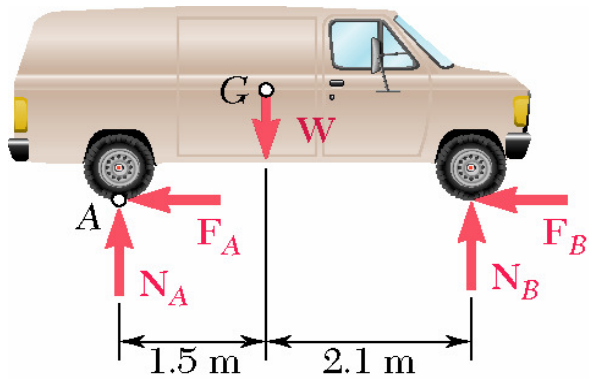

- Apply the corresponding scalar equations.

$$+\curvearrowright \sum M_A = \sum (M_A)_{eff}$$

$$-(1.5 \text{ m})W + (3.6 \text{ m})N_B = (1.2 \text{ m})m\bar{a}$$

$$N_B = \frac{1}{3.6} \left(5W + 1.2 \frac{W}{g} \bar{a} \right) = \frac{W}{3.6} \left(1.5 + 1.2 \frac{\bar{a}}{g} \right)$$

$$N_B = 17.16 \text{ kN}$$

$$N_A = W - N_B = 7.37 \text{ kN}$$

$$N_{rear} = \frac{1}{2} N_A = 3.69 \text{ kN}$$

$$N_{rear} = 3.69 \text{ kN}$$

$$F_{rear} = \mu_k N_{rear} = (0.849)(3.69 \text{ kN})$$

$$F_{rear} = 3.13 \text{ kN}$$

$$N_{front} = \frac{1}{2} N_V = \frac{1}{2} (17.16 \text{ kN})$$

$$N_{front} = 8.58 \text{ kN}$$

$$F_{front} = \mu_k N_{front} = (0.849)(8.58 \text{ kN})$$

$$F_{front} = 7.29 \text{ kN}$$

Vector Mechanics for Engineers: Dynamics

Sample Problem 16.2

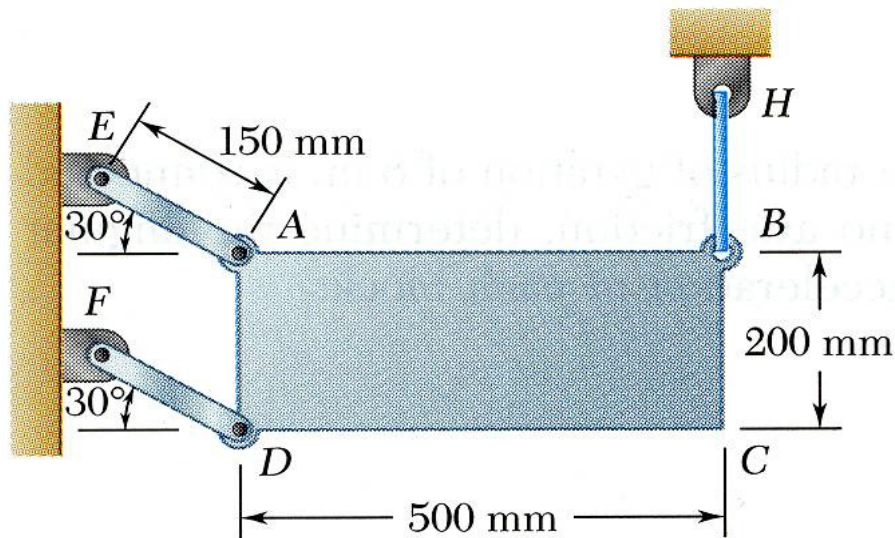

The thin plate of mass 8 kg is held in place as shown.

Neglecting the mass of the links, determine immediately after the wire has been cut (a) the acceleration of the plate, and (b) the force in each link.

SOLUTION:

- Note that after the wire is cut, all particles of the plate move along parallel circular paths of radius 150 mm. The plate is in curvilinear translation.
- Draw the free-body-diagram equation expressing the equivalence of the external and effective forces.
- Resolve into scalar component equations parallel and perpendicular to the path of the mass center.
- Solve the component equations and the moment equation for the unknown acceleration and link forces.

Vector Mechanics for Engineers: Dynamics

Sample Problem 16.2

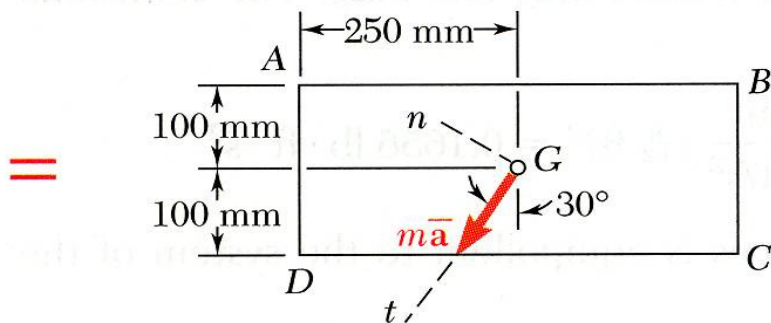
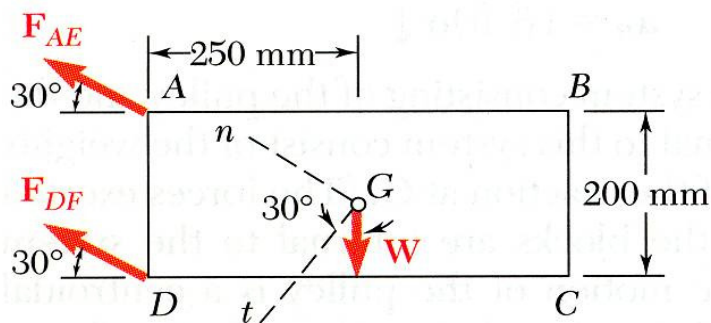
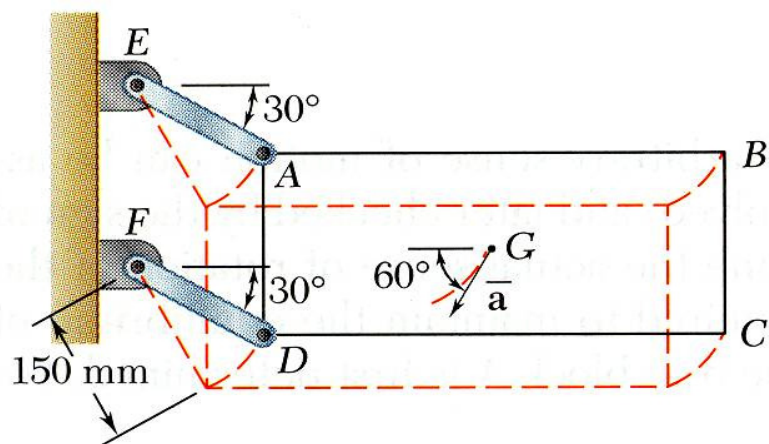

SOLUTION:

- Note that after the wire is cut, all particles of the plate move along parallel circular paths of radius 150 mm. The plate is in curvilinear translation.
- Draw the free-body-diagram equation expressing the equivalence of the external and effective forces.
- Resolve the diagram equation into components parallel and perpendicular to the path of the mass center.

$$+\swarrow \sum F_t = \sum (F_t)_{eff}$$

$$W \cos 30^\circ = m\bar{a}$$

$$mg \cos 30^\circ =$$

$$\bar{a} = (9.81 \text{ m/s}^2) \cos 30^\circ$$

$$\bar{a} = 8.50 \text{ m/s}^2 \swarrow 60^\circ$$

Vector Mechanics for Engineers: Dynamics

Sample Problem 16.2

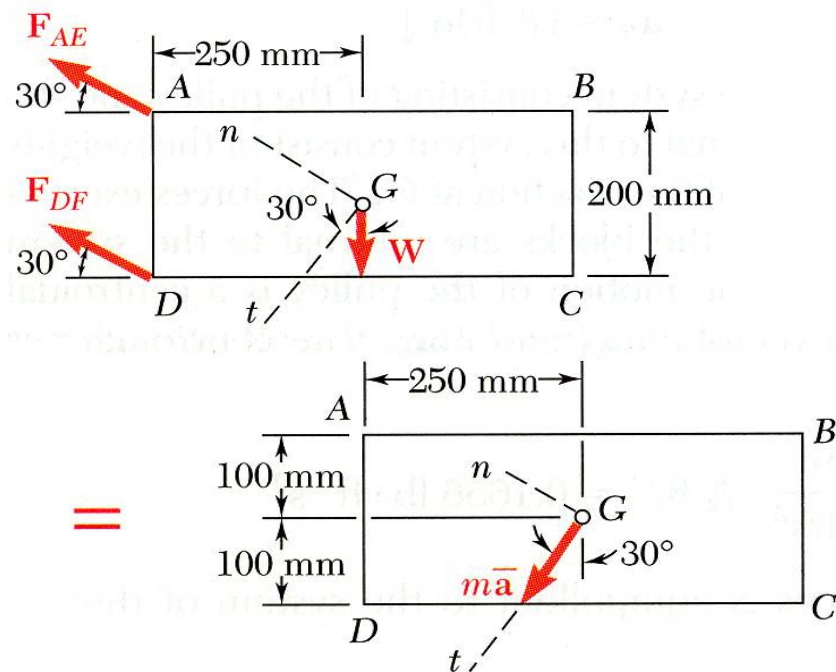

$$\bar{a} = 8.50 \text{ m/s}^2 \nearrow 60^\circ$$

- Solve the component equations and the moment equation for the unknown acceleration and link forces.

$$+\curvearrowright \sum M_G = (\sum M_G)_{eff}$$

$$(F_{AE} \sin 30^\circ)(250 \text{ mm}) - (F_{AE} \cos 30^\circ)(100 \text{ mm}) \\ (F_{DF} \sin 30^\circ)(250 \text{ mm}) + (F_{DF} \cos 30^\circ)(100 \text{ mm}) = 0$$

$$38.4 F_{AE} + 211.6 F_{DF} = 0$$

$$F_{DF} = -0.1815 F_{AE}$$

$$+\nearrow \sum F_n = \sum (F_n)_{eff}$$

$$F_{AE} + F_{DF} - W \sin 30^\circ = 0$$

$$F_{AE} - 0.1815 F_{AE} - W \sin 30^\circ = 0$$

$$F_{AE} = 0.619(8 \text{ kg})(9.81 \text{ m/s}^2)$$

$$F_{AE} = 47.9 \text{ N} \quad T$$

$$F_{DF} = -0.1815(47.9 \text{ N})$$

$$F_{DF} = 8.70 \text{ N} \quad C$$

Vector Mechanics for Engineers: Dynamics

Sample Problem 16.3

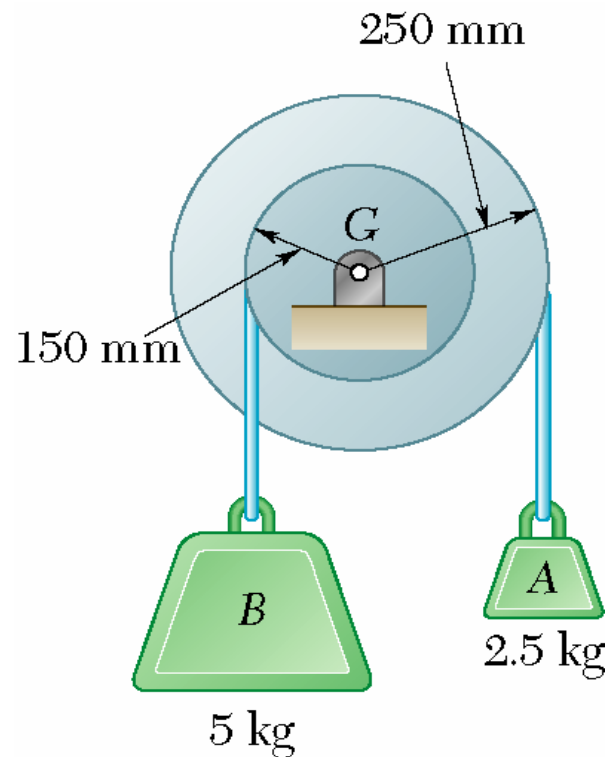

A pulley weighing 6 kg and having a radius of gyration of 200 mm is connected to two blocks as shown.

Assuming no axle friction, determine the angular acceleration of the pulley and the acceleration of each block.

SOLUTION:

- Determine the direction of rotation by evaluating the net moment on the pulley due to the two blocks.
- Relate the acceleration of the blocks to the angular acceleration of the pulley.
- Draw the free-body-diagram equation expressing the equivalence of the external and effective forces on the complete pulley plus blocks system.
- Solve the corresponding moment equation for the pulley angular acceleration.

Vector Mechanics for Engineers: Dynamics

Sample Problem 16.3

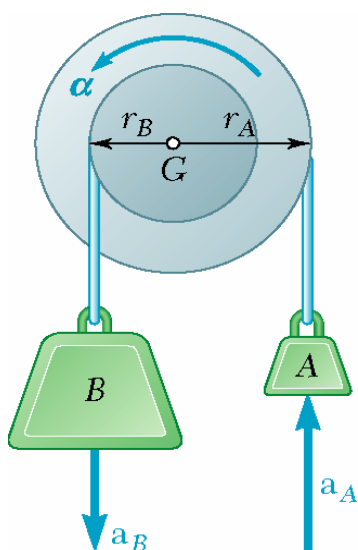
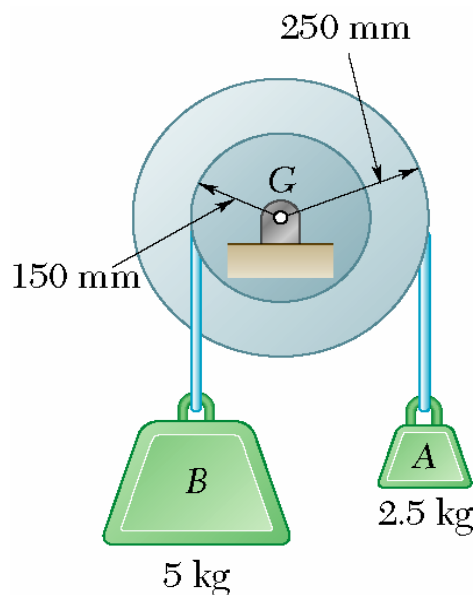

SOLUTION:

- Determine the direction of rotation by evaluating the net moment on the pulley due to the two blocks.

$$+\curvearrowright \sum M_G = (5 \text{ kg})(150 \text{ mm}) - (2.5 \text{ kg})(250 \text{ mm}) = 10 \text{ in} \cdot \text{lb}$$

rotation is counterclockwise.

note: $\bar{I} = m\bar{k}^2 = \frac{W}{g} \bar{k}^2$

$$= \frac{6 \text{ kg}}{32.2 \text{ ft/s}^2} \left(\frac{8}{12} \text{ ft} \right)^2$$

$$= 0.24 \text{ kg} \cdot \text{m}^2$$

- Relate the acceleration of the blocks to the angular acceleration of the pulley.

$$\begin{aligned} a_A &= r_A \alpha & a_B &= r_b \alpha \\ &= (0.25 \text{ m}) \alpha & &= (0.15 \text{ m}) \end{aligned}$$

Vector Mechanics for Engineers: Dynamics

Sample Problem 16.3

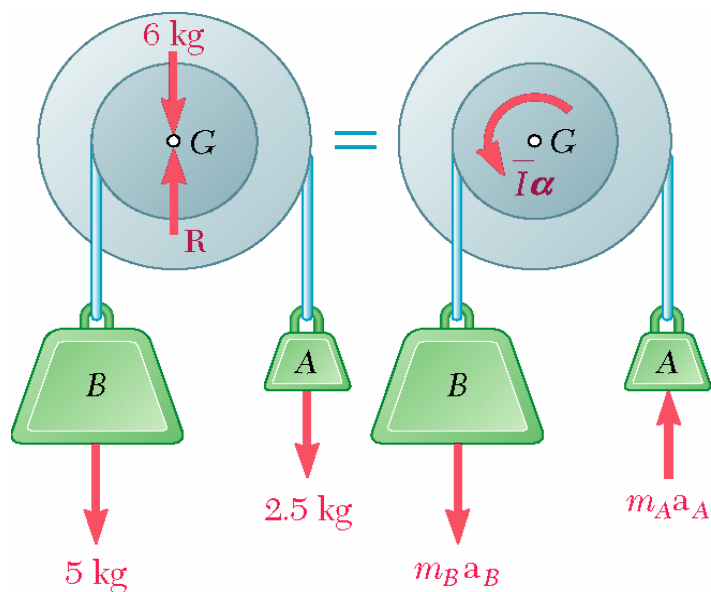

- Draw the free-body-diagram equation expressing the equivalence of the external and effective forces on the complete pulley and blocks system.
- Solve the corresponding moment equation for the pulley angular acceleration.

$$\begin{aligned}
 +\curvearrowright \sum M_G &= \sum (M_G)_{eff} \\
 &= (49.1 \text{ N})(0.15 \text{ m}) - (24.5 \text{ N})(0.25 \text{ m}) \\
 &= \bar{I}\alpha + m_B a_B (0.15 \text{ m}) - m_A a_A (0.25 \text{ m}) \\
 &= (49.1)(0.15) - (24.5)(0.25) \\
 &= (0.24)\alpha + (5)(0.15 \alpha)(0.15) - (2.5)(0.25)(0.25)
 \end{aligned}$$

$$\alpha = 2.374 \text{ rad/s}^2 \curvearrowright$$

$$\begin{aligned}
 \bar{I} &= 0.24 \text{ kg} \cdot \text{m}^2 \\
 a_A &= (0.25 \text{ m})\alpha \\
 a_B &= (0.15 \text{ m})\alpha
 \end{aligned}$$

Then,

$$\begin{aligned}
 a_A &= r_A \alpha \\
 &= (0.25 \text{ m})(2.374 \text{ rad/s}^2)
 \end{aligned}$$

$$a_A = 0.61 \text{ m/s}^2 \uparrow$$

$$\begin{aligned}
 a_B &= r_B \alpha \\
 &= (0.15 \text{ m})(2.374 \text{ rad/s}^2)
 \end{aligned}$$

$$a_B = 0.37 \text{ m/s}^2 \downarrow$$

Vector Mechanics for Engineers: Dynamics

Sample Problem 16.4

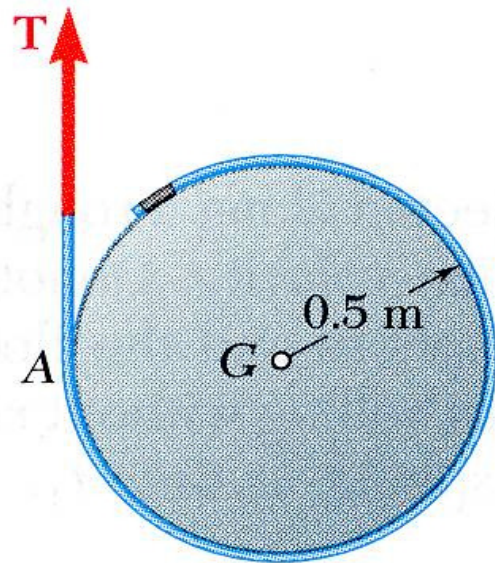

A cord is wrapped around a homogeneous disk of mass 15 kg. The cord is pulled upwards with a force $T = 180$ N.

Determine: (a) the acceleration of the center of the disk, (b) the angular acceleration of the disk, and (c) the acceleration of the cord.

SOLUTION:

- Draw the free-body-diagram equation expressing the equivalence of the external and effective forces on the disk.
- Solve the three corresponding scalar equilibrium equations for the horizontal, vertical, and angular accelerations of the disk.
- Determine the acceleration of the cord by evaluating the tangential acceleration of the point A on the disk.

Vector Mechanics for Engineers: Dynamics

Sample Problem 16.4

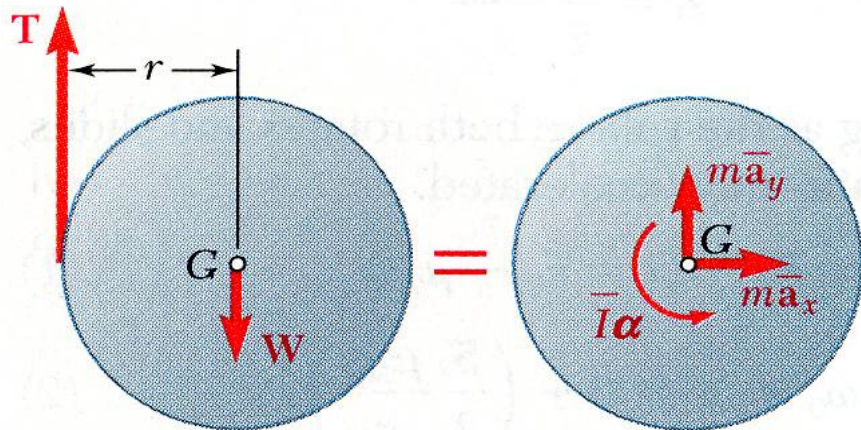

SOLUTION:

- Draw the free-body-diagram equation expressing the equivalence of the external and effective forces on the disk.
- Solve the three scalar equilibrium equations.

$$+\rightarrow \sum F_x = \sum (F_x)_{eff}$$

$$0 = m\bar{a}_x$$

$$\boxed{\bar{a}_x = 0}$$

$$+\uparrow \sum F_y = \sum (F_y)_{eff}$$

$$T - W = m\bar{a}_y$$

$$\bar{a}_y = \frac{T - W}{m} = \frac{180 \text{ N} - (15 \text{ kg})(9.81 \text{ m/s}^2)}{15 \text{ kg}}$$

$$\boxed{\bar{a}_y = 2.19 \text{ m/s}^2 \uparrow}$$

$$+\curvearrowright \sum M_G = \sum (M_G)_{eff}$$

$$-Tr = \bar{I}\alpha = \left(\frac{1}{2}mr^2\right)\alpha$$

$$\alpha = -\frac{2T}{mr} = -\frac{2(180 \text{ N})}{(15 \text{ kg})(0.5 \text{ m})}$$

$$\boxed{\alpha = 48.0 \text{ rad/s}^2 \curvearrowright}$$

Vector Mechanics for Engineers: Dynamics

Sample Problem 16.4

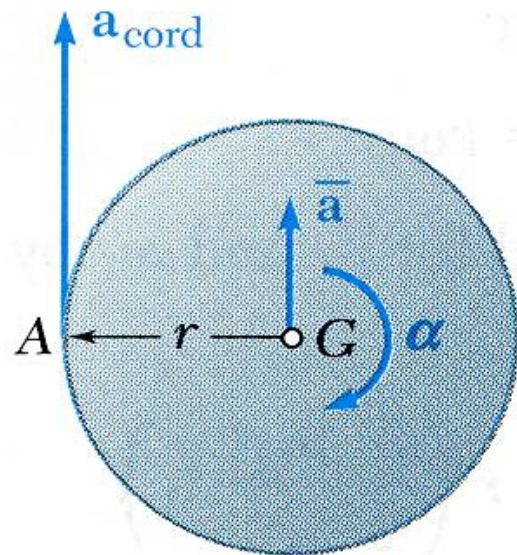

- Determine the acceleration of the cord by evaluating the tangential acceleration of the point A on the disk.

$$\begin{aligned}\vec{a}_{cord} &= (a_A)_t = \bar{a} + (a_{A/G})_t \\ &= 2.19 \text{ m/s}^2 + (0.5 \text{ m})(48 \text{ rad/s}^2)\end{aligned}$$

$$a_{cord} = 26.2 \text{ m/s}^2 \uparrow$$

$$\bar{a}_x = 0 \quad \bar{a}_y = 2.19 \text{ m/s}^2 \uparrow$$

$$\alpha = 48.0 \text{ rad/s}^2 \curvearrowright$$



Vector Mechanics for Engineers: Dynamics

Sample Problem 16.5

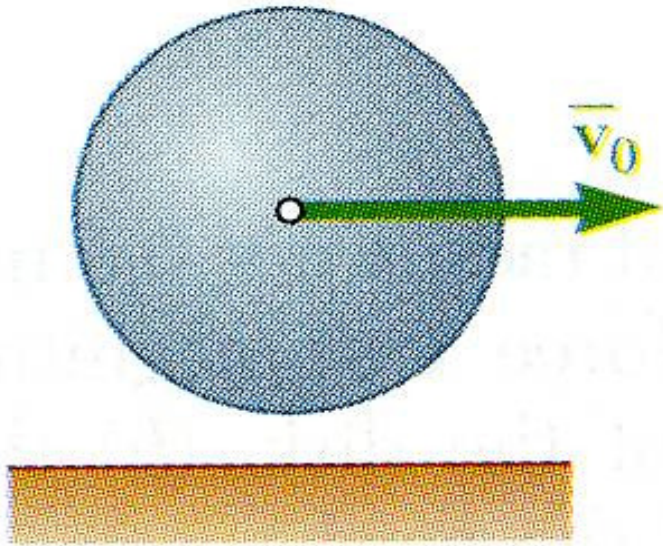

A uniform sphere of mass m and radius r is projected along a rough horizontal surface with a linear velocity v_0 . The coefficient of kinetic friction between the sphere and the surface is μ_k .

Determine: (a) the time t_1 at which the sphere will start rolling without sliding, and (b) the linear and angular velocities of the sphere at time t_1 .

SOLUTION:

- Draw the free-body-diagram equation expressing the equivalence of the external and effective forces on the sphere.
- Solve the three corresponding scalar equilibrium equations for the normal reaction from the surface and the linear and angular accelerations of the sphere.
- Apply the kinematic relations for uniformly accelerated motion to determine the time at which the tangential velocity of the sphere at the surface is zero, i.e., when the sphere stops sliding.

Vector Mechanics for Engineers: Dynamics

Sample Problem 16.5

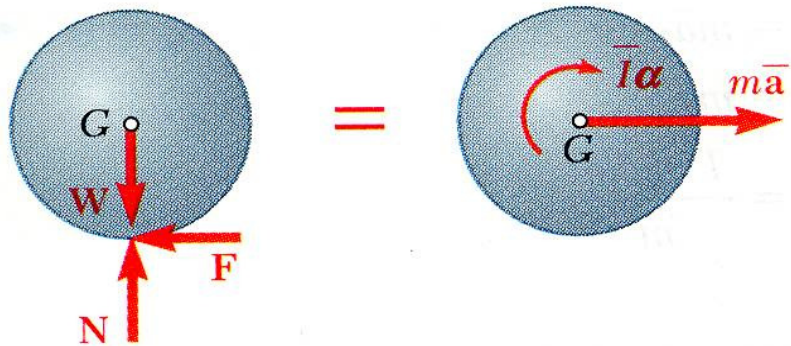

SOLUTION:

- Draw the free-body-diagram equation expressing the equivalence of external and effective forces on the sphere.
- Solve the three scalar equilibrium equations.

$$+\uparrow \sum F_y = \sum (F_y)_{eff}$$

$$N - W = 0$$

$$N = W = mg$$

$$+\rightarrow \sum F_x = \sum (F_x)_{eff}$$

$$-F = m\bar{a}$$

$$-\mu_k mg =$$

$$\bar{a} = -\mu_k g$$

$$+\curvearrowright \sum M_G = \sum (M_G)_{eff}$$

$$Fr = \bar{I}\alpha$$

$$(\mu_k mg)r = \left(\frac{2}{3}mr^2\right)\alpha$$

$$\alpha = \frac{5}{2} \frac{\mu_k g}{r}$$

NOTE: As long as the sphere both rotates and slides, its linear and angular motions are uniformly accelerated.

Vector Mechanics for Engineers: Dynamics

Sample Problem 16.5

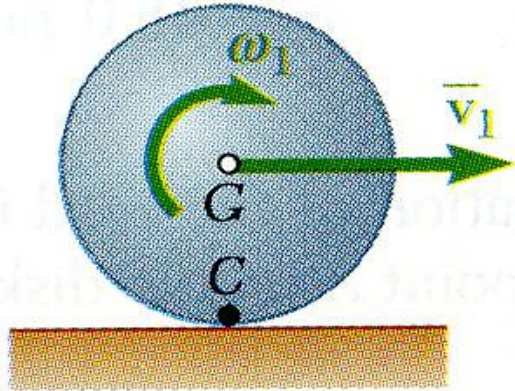

- Apply the kinematic relations for uniformly accelerated motion to determine the time at which the tangential velocity of the sphere at the surface is zero, i.e., when the sphere stops sliding.

$$\bar{v} = \bar{v}_0 + \bar{a}t = \bar{v}_0 + (-\mu_k g)t$$

$$\omega = \omega_0 + \alpha t = 0 + \left(\frac{5}{2} \frac{\mu_k g}{r}\right)t$$

At the instant t_1 when the sphere stops sliding,

$$\bar{a} = -\mu_k g$$

$$\alpha = \frac{5}{2} \frac{\mu_k g}{r}$$

$$\bar{v}_1 = r\omega_1$$

$$\bar{v}_0 - \mu_k g t_1 = r \left(\frac{5}{2} \frac{\mu_k g}{r}\right) t_1$$

$$t_1 = \frac{2}{7} \frac{\bar{v}_0}{\mu_k g}$$

$$\omega_1 = \left(\frac{5}{2} \frac{\mu_k g}{r}\right) t_1 = \left(\frac{5}{2} \frac{\mu_k g}{r}\right) \left(\frac{2}{7} \frac{\bar{v}_0}{\mu_k g}\right)$$

$$\omega_1 = \frac{5}{7} \frac{\bar{v}_0}{r}$$

$$\bar{v}_1 = r\omega_1 = r \left(\frac{5}{7} \frac{\bar{v}_0}{r}\right)$$

$$\bar{v}_1 = \frac{5}{7} \bar{v}_0$$

Vector Mechanics for Engineers: Dynamics

Constrained Plane Motion

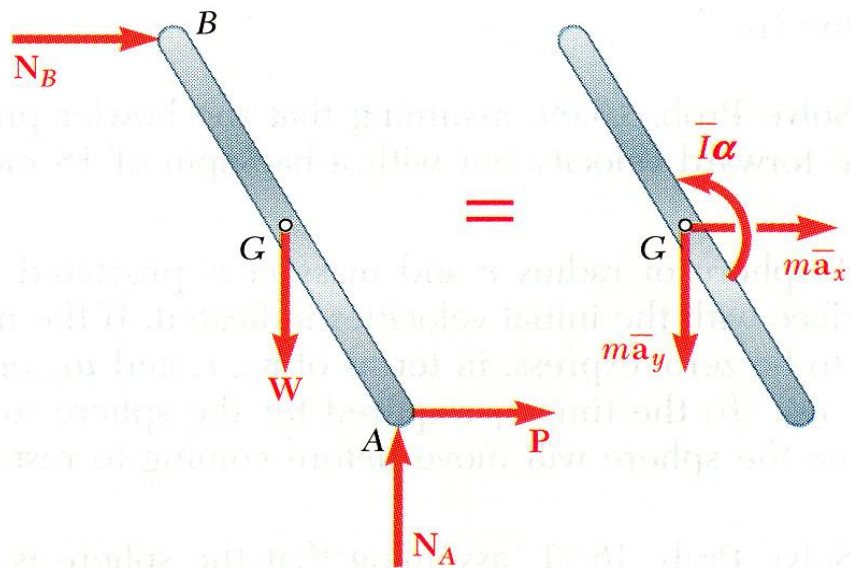
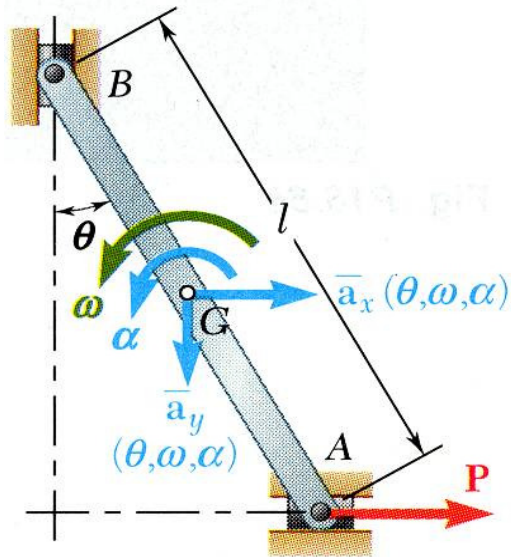

- Most engineering applications involve rigid bodies which are moving under given constraints, e.g., cranks, connecting rods, and non-slipping wheels.
- *Constrained plane motion*: motions with definite relations between the components of acceleration of the mass center and the angular acceleration of the body.
- Solution of a problem involving constrained plane motion begins with a kinematic analysis.
- e.g., given θ , ω , and α , find P , N_A , and N_B .
 - kinematic analysis yields \bar{a}_x and \bar{a}_y .
 - application of d'Alembert's principle yields P , N_A , and N_B .

Vector Mechanics for Engineers: Dynamics

Constrained Motion: Noncentroidal Rotation

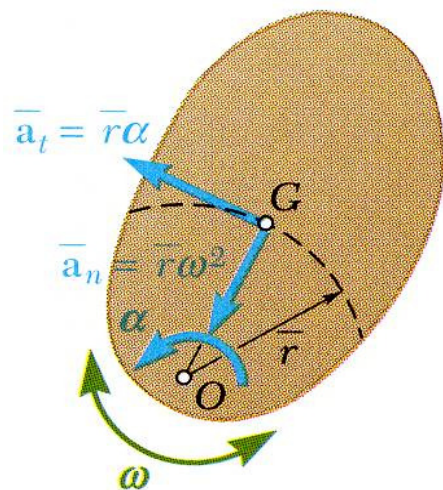

- *Noncentroidal rotation*: motion of a body is constrained to rotate about a fixed axis that does not pass through its mass center.
- Kinematic relation between the motion of the mass center G and the motion of the body about G ,

$$\bar{a}_t = r\alpha \quad \bar{a}_n = r\omega^2$$

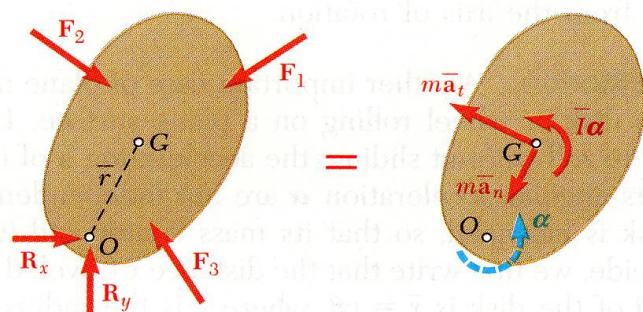

- The kinematic relations are used to eliminate \bar{a}_t and \bar{a}_n from equations derived from d'Alembert's principle or from the method of dynamic equilibrium.

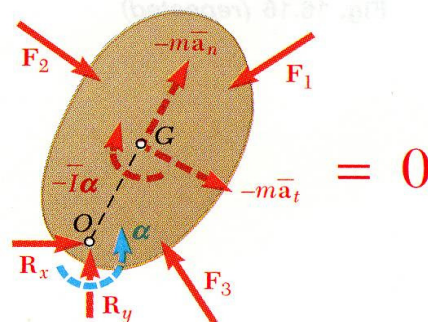

Vector Mechanics for Engineers: Dynamics

Constrained Plane Motion: Rolling Motion

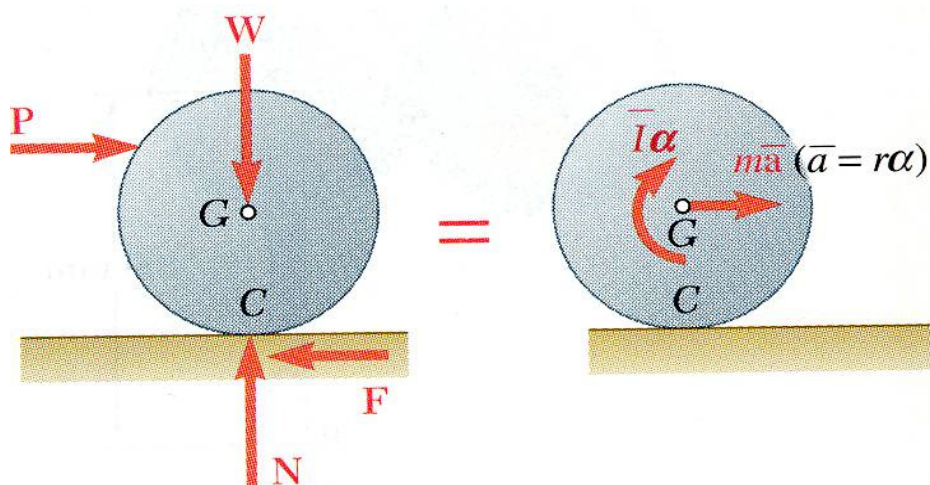

- For a balanced disk constrained to roll without sliding,

$$\bar{x} = r\theta \quad \rightarrow \quad \bar{a} = r\alpha$$

- Rolling, no sliding:

$$F \leq \mu_s N \quad \bar{a} = r\alpha$$

Rolling, sliding impending:

$$F = \mu_s N \quad \bar{a} = r\alpha$$

Rotating and sliding:

$$F = \mu_k N \quad \bar{a}, r\alpha \text{ independent}$$

- For the geometric center of an unbalanced disk,

$$a_O = r\alpha$$

The acceleration of the mass center,

$$\begin{aligned} \vec{a}_G &= \vec{a}_O + \vec{a}_{G/O} \\ &= \vec{a}_O + (\vec{a}_{G/O})_t + (\vec{a}_{G/O})_n \end{aligned}$$

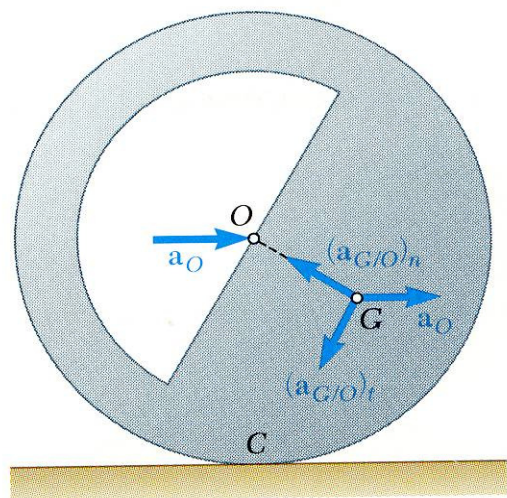

Vector Mechanics for Engineers: Dynamics

Sample Problem 16.6

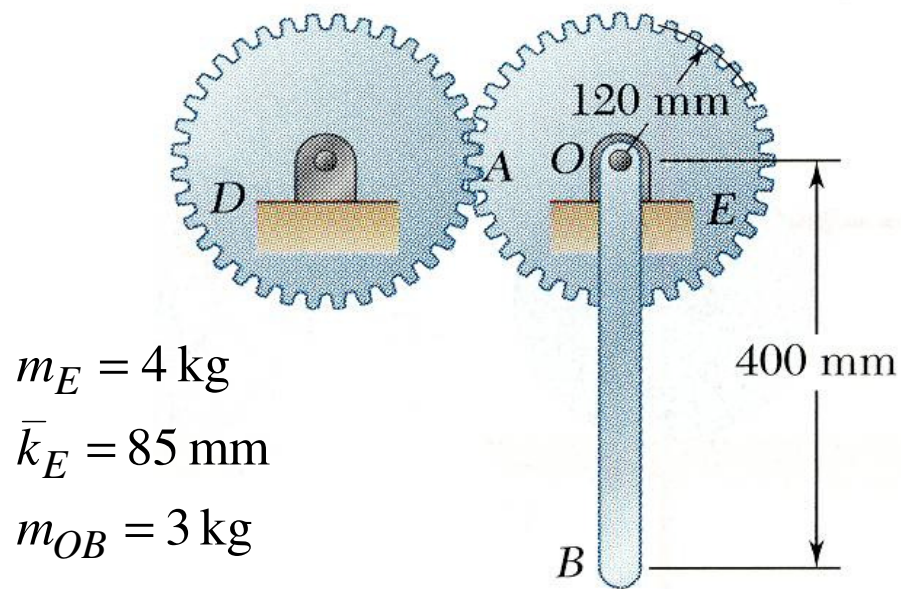

The portion AOB of the mechanism is actuated by gear D and at the instant shown has a clockwise angular velocity of 8 rad/s and a counterclockwise angular acceleration of 40 rad/s^2 .

Determine: a) tangential force exerted by gear D , and b) components of the reaction at shaft O .

SOLUTION:

- Draw the free-body-equation for AOB , expressing the equivalence of the external and effective forces.
- Evaluate the external forces due to the weights of gear E and arm OB and the effective forces associated with the angular velocity and acceleration.
- Solve the three scalar equations derived from the free-body-equation for the tangential force at A and the horizontal and vertical components of reaction at shaft O .

Vector Mechanics for Engineers: Dynamics

Sample Problem 16.6

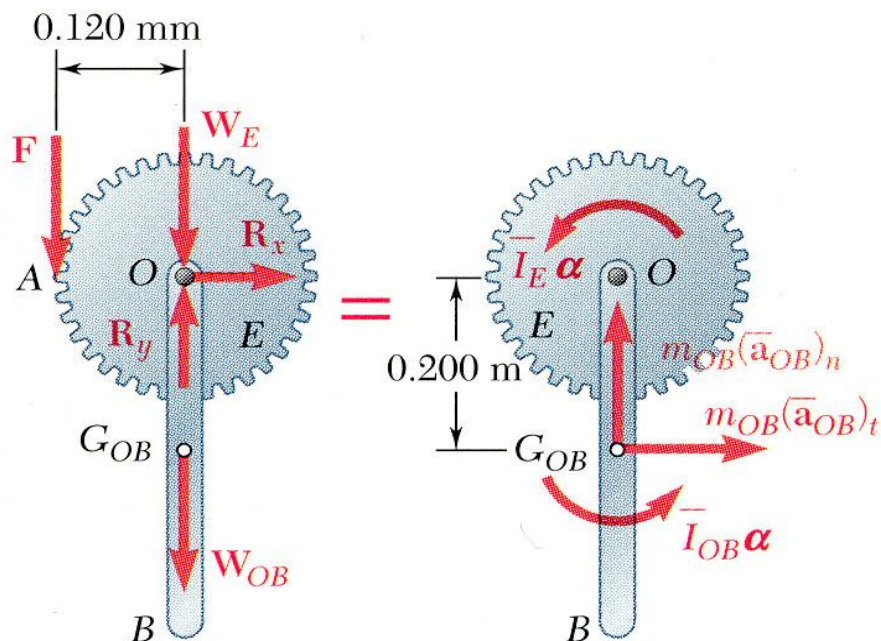

SOLUTION:

- Draw the free-body-equation for AOB .
- Evaluate the external forces due to the weights of gear E and arm OB and the effective forces.

$$W_E = (4 \text{ kg})(9.81 \text{ m/s}^2) = 39.2 \text{ N}$$

$$W_{OB} = (3 \text{ kg})(9.81 \text{ m/s}^2) = 29.4 \text{ N}$$

$$\begin{aligned} \bar{I}_E \alpha &= m_E \bar{k}_E^2 \alpha = (4 \text{ kg})(0.085 \text{ m})^2 (40 \text{ rad/s}^2) \\ &= 1.156 \text{ N} \cdot \text{m} \end{aligned}$$

$$\begin{aligned} m_{OB} (\bar{a}_{OB})_t &= m_{OB} (\bar{r} \alpha) = (3 \text{ kg})(0.200 \text{ m})(40 \text{ rad/s}^2) \\ &= 24.0 \text{ N} \end{aligned}$$

$$\begin{aligned} m_{OB} (\bar{a}_{OB})_n &= m_{OB} (\bar{r} \omega^2) = (3 \text{ kg})(0.200 \text{ m})(8 \text{ rad/s})^2 \\ &= 38.4 \text{ N} \end{aligned}$$

$$\begin{aligned} \bar{I}_{OB} \alpha &= \left(\frac{1}{12} m_{OB} L^2 \right) \alpha = \frac{1}{12} (3 \text{ kg})(0.400 \text{ m})^2 (40 \text{ rad/s}^2) \\ &= 1.600 \text{ N} \cdot \text{m} \end{aligned}$$

$$m_E = 4 \text{ kg} \quad \alpha = 40 \text{ rad/s}^2 \quad \curvearrowright$$

$$\bar{k}_E = 85 \text{ mm} \quad \omega = 8 \text{ rad/s} \quad \curvearrowright$$

$$m_{OB} = 3 \text{ kg}$$



Vector Mechanics for Engineers: Dynamics

Sample Problem 16.6

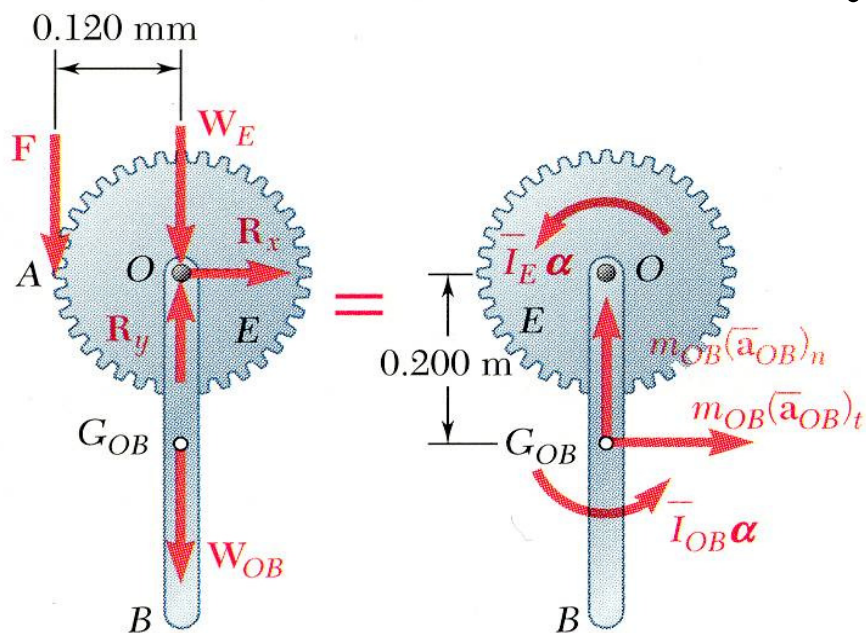

- Solve the three scalar equations derived from the free-body-equation for the tangential force at A and the horizontal and vertical components of reaction at O.

$$+\curvearrowright \sum M_O = (\sum M_O)_{eff}$$

$$F(0.120\text{ m}) = \bar{I}_E \alpha + m_{OB} (\bar{a}_{OB})_t (0.200\text{ m}) + \bar{I}_{OB} \alpha$$

$$= 1.156\text{ N} \cdot \text{m} + (24.0\text{ N})(0.200\text{ m}) + 1.600\text{ N} \cdot \text{m}$$

$$F = 63.0\text{ N} \downarrow$$

$$+\rightarrow \sum F_x = (\sum F_x)_{eff}$$

$$R_x = m_{OB} (a_{OB})_t = 24.0\text{ N}$$

$$R_x = 24.0\text{ N} \rightarrow$$

$$+\uparrow \sum F_y = (\sum F_y)_{eff}$$

$$R_y - F - W_E - W_{OB} = m_{OB} (\bar{a}_{OB})_n$$

$$R_y - 63.0\text{ N} - 39.2\text{ N} - 29.4\text{ N} = 38.4\text{ N}$$

$$R_y = 24.0\text{ N} \uparrow$$

$$W_E = 39.2\text{ N}$$

$$W_{OB} = 29.4\text{ N}$$

$$\bar{I}_E \alpha = 1.156\text{ N} \cdot \text{m}$$

$$m_{OB} (\bar{a}_{OB})_t = 24.0\text{ N}$$

$$m_{OB} (\bar{a}_{OB})_n = 38.4\text{ N}$$

$$\bar{I}_{OB} \alpha = 1.600\text{ N} \cdot \text{m}$$

Vector Mechanics for Engineers: Dynamics

Sample Problem 16.8

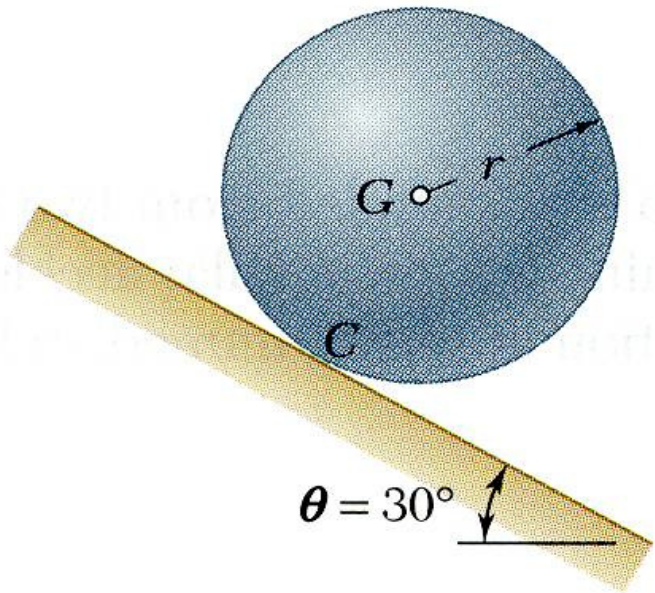

A sphere of weight W is released with no initial velocity and rolls without slipping on the incline.

Determine: *a*) the minimum value of the coefficient of friction, *b*) the velocity of G after the sphere has rolled 3 m and *c*) the velocity of G if the sphere were to move 3 m down a frictionless incline.

SOLUTION:

- Draw the free-body-equation for the sphere, expressing the equivalence of the external and effective forces.
- With the linear and angular accelerations related, solve the three scalar equations derived from the free-body-equation for the angular acceleration and the normal and tangential reactions at C .
- Calculate the friction coefficient required for the indicated tangential reaction at C .
- Calculate the velocity after 3 m of uniformly accelerated motion.
- Assuming no friction, calculate the linear acceleration down the incline and the corresponding velocity after 3 m.

Vector Mechanics for Engineers: Dynamics

Sample Problem 16.8

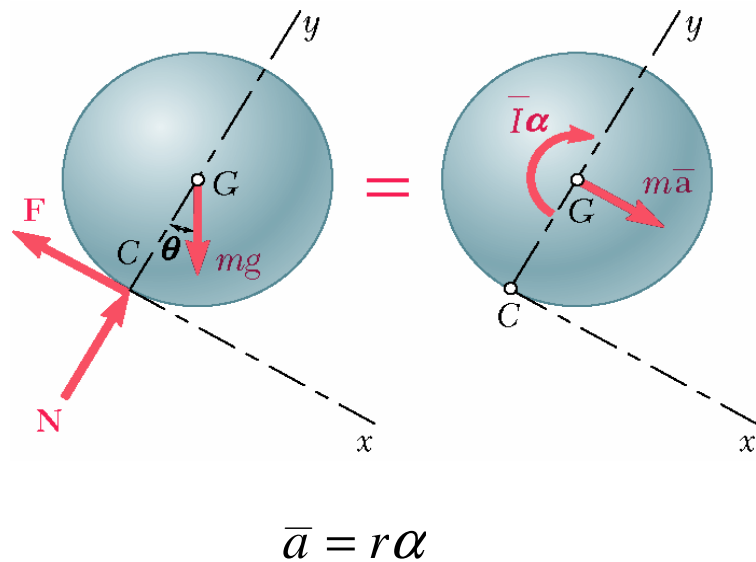

SOLUTION:

- Draw the free-body-equation for the sphere, expressing the equivalence of the external and effective forces.
- With the linear and angular accelerations related, solve the three scalar equations derived from the free-body-equation for the angular acceleration and the normal and tangential reactions at C.

$$\sum M_C = \sum (M_C)_{eff}$$

$$(W \sin \theta)r = (m\bar{a})r + \bar{I}\alpha$$

$$= (mr\alpha)r + \left(\frac{2}{5}mr^2\right)\alpha$$

$$= \left(\frac{W}{g}r\alpha\right)r + \left(\frac{2}{5}\frac{W}{g}r^2\right)\alpha \quad \alpha = \frac{5g \sin \theta}{7r}$$

$$\bar{a} = r\alpha = \frac{5g \sin 30^\circ}{7}$$

$$= \frac{5(9.81 \text{ m/s}^2)\sin 30^\circ}{7}$$

$$\bar{a} = 3.5 \text{ m/s}^2$$

Vector Mechanics for Engineers: Dynamics

Sample Problem 16.8

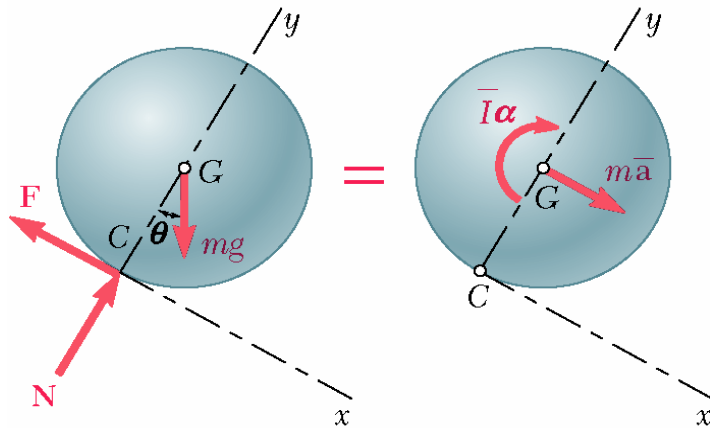

$$\alpha = \frac{5g \sin \theta}{7r}$$

$$\bar{a} = r\alpha = 3.5 \text{ m/s}^2$$

- Solve the three scalar equations derived from the free-body-equation for the angular acceleration and the normal and tangential reactions at C.

$$\begin{aligned} \sum F_x = \sum (F_x)_{eff} \quad mg \sin \theta - F &= m\bar{a} \\ &= \frac{mg}{g} \frac{5g \sin \theta}{7} \end{aligned}$$

$$F = \frac{2}{7} mg \sin 30^\circ = 0.143 mg$$

$$\sum F_y = \sum (F_y)_{eff} \quad N - mg \cos \theta = 0$$

$$N = mg \cos 30^\circ = 0.866 mg$$

- Calculate the friction coefficient required for the indicated tangential reaction at C.

$$F = \mu_s N$$

$$\mu_s = \frac{F}{N} = \frac{0.143 mg}{0.866 mg}$$

$$\mu_s = 0.165$$

Vector Mechanics for Engineers: Dynamics

Sample Problem 16.8

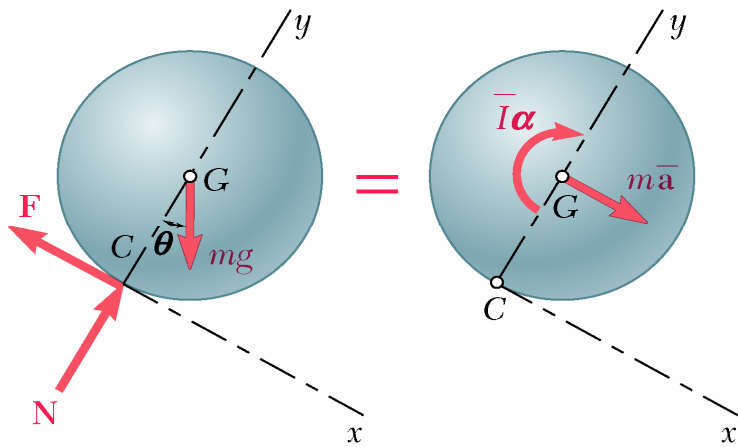

$$\alpha = \frac{5g \sin \theta}{7r}$$

$$\bar{a} = r\alpha = 3.5 \text{ m/s}^2$$

- Calculate the velocity after 3 m of uniformly accelerated motion.

$$\begin{aligned} \bar{v}^2 &= \bar{v}_0^2 + 2\bar{a}(\bar{x} - \bar{x}_0) \\ &= 0 + 2(3.5 \text{ m/s}^2)(3 \text{ m}) \end{aligned}$$

$$\bar{v} = 4.6 \text{ m/s}$$

- Assuming no friction, calculate the linear acceleration and the corresponding velocity after 3 m.

$$\sum M_G = \sum (M_G)_{\text{eff}} \quad 0 = I\alpha \quad \alpha = 0$$

$$\begin{aligned} \sum F_x &= \sum (F_x)_{\text{eff}} & mg \sin 30^\circ &= m\bar{a} \\ \bar{a} &= (9.81 \text{ m/s}^2) \sin 30^\circ = 4.91 \text{ m/s}^2 \end{aligned}$$

$$\begin{aligned} \bar{v}^2 &= \bar{v}_0^2 + 2\bar{a}(\bar{x} - \bar{x}_0) \\ &= 0 + 2(4.91 \text{ m/s}^2)(3 \text{ m}) \end{aligned}$$

$$\bar{v} = 5.43 \text{ m/s}$$

Vector Mechanics for Engineers: Dynamics

Sample Problem 16.9

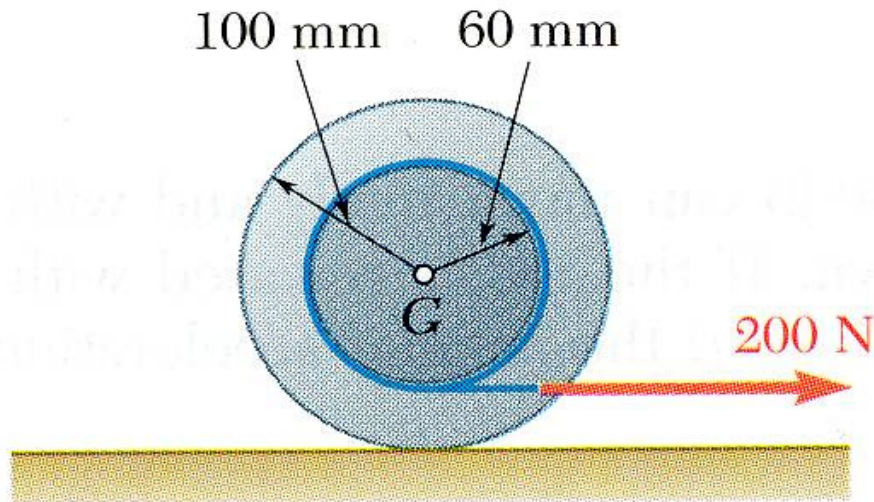

A cord is wrapped around the inner hub of a wheel and pulled horizontally with a force of 200 N. The wheel has a mass of 50 kg and a radius of gyration of 70 mm. Knowing $\mu_s = 0.20$ and $\mu_k = 0.15$, determine the acceleration of G and the angular acceleration of the wheel.

SOLUTION:

- Draw the free-body-equation for the wheel, expressing the equivalence of the external and effective forces.
- Assuming rolling without slipping and therefore, related linear and angular accelerations, solve the scalar equations for the acceleration and the normal and tangential reactions at the ground.
- Compare the required tangential reaction to the maximum possible friction force.
- If slipping occurs, calculate the kinetic friction force and then solve the scalar equations for the linear and angular accelerations.

Vector Mechanics for Engineers: Dynamics

Sample Problem 16.9

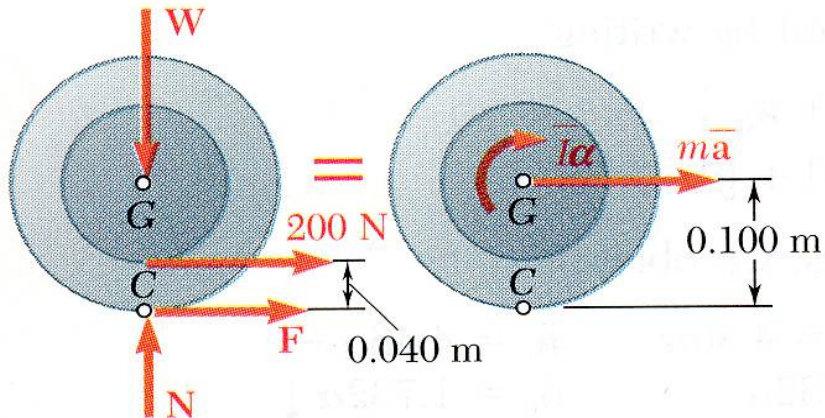

$$\begin{aligned}\bar{I} &= m\bar{k}^2 = (50\text{ kg})(0.70\text{ m})^2 \\ &= 0.245\text{ kg} \cdot \text{m}^2\end{aligned}$$

Assume rolling without slipping,

$$\begin{aligned}\bar{a} &= r\alpha \\ &= (0.100\text{ m})\alpha\end{aligned}$$

SOLUTION:

- Draw the free-body-equation for the wheel,
- Assuming rolling without slipping, solve the scalar equations for the acceleration and ground reactions.

$$\begin{aligned}+\curvearrowright \sum M_C &= \sum (M_C)_{eff} \\ (200\text{ N})(0.040\text{ m}) &= m\bar{a}(0.100\text{ m}) + \bar{I}\alpha \\ 8.0\text{ N} \cdot \text{m} &= (50\text{ kg})(0.100\text{ m})^2 \alpha + (0.245\text{ kg} \cdot \text{m}^2) \alpha \\ \alpha &= +10.74\text{ rad/s}^2 \quad \curvearrowright \\ \bar{a} &= (0.100\text{ m})(10.74\text{ rad/s}^2) = 1.074\text{ m/s}^2 \rightarrow\end{aligned}$$

$$\begin{aligned}+\rightarrow \sum F_x &= \sum (F_x)_{eff} \\ F + 200\text{ N} &= m\bar{a} = (50\text{ kg})(1.074\text{ m/s}^2) \\ F &= -146.3\text{ N} \quad \leftarrow\end{aligned}$$

$$\begin{aligned}+\rightarrow \sum F_x &= \sum (F_x)_{eff} \\ N - W &= 0 \\ N = mg &= (50\text{ kg})(1.074\text{ m/s}^2) = +490.5\text{ N} \uparrow\end{aligned}$$

Vector Mechanics for Engineers: Dynamics

Sample Problem 16.9

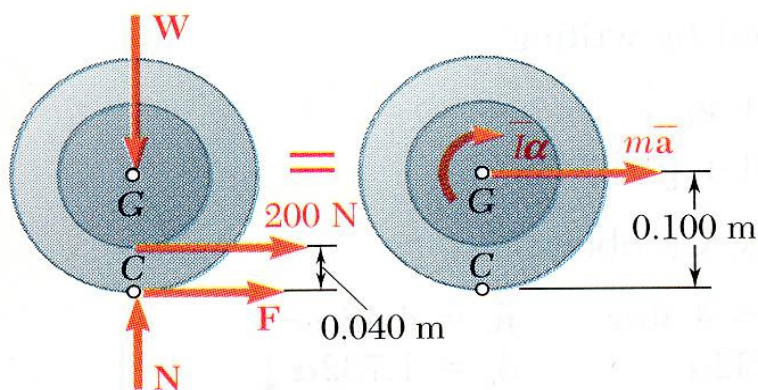

Without slipping,

$$F = -146.3 \text{ N} \quad N = 490.5 \text{ N}$$

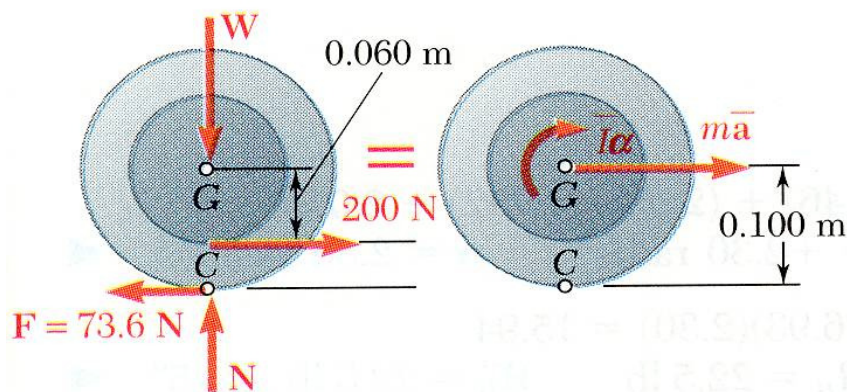

- Compare the required tangential reaction to the maximum possible friction force.

$$F_{\max} = \mu_s N = 0.20(490.5 \text{ N}) = 98.1 \text{ N}$$

$F > F_{\max}$, rolling without slipping is impossible.

- Calculate the friction force with slipping and solve the scalar equations for linear and angular accelerations.

$$F = F_k = \mu_k N = 0.15(490.5 \text{ N}) = 73.6 \text{ N}$$

$$\rightarrow \sum F_x = \sum (F_x)_{\text{eff}}$$

$$200 \text{ N} - 73.6 \text{ N} = (50 \text{ kg})\bar{a}$$

$$\bar{a} = 2.53 \text{ m/s}^2 \rightarrow$$

$$+\curvearrowright \sum M_G = \sum (M_G)_{\text{eff}}$$

$$(73.6 \text{ N})(0.100 \text{ m}) - (200 \text{ N})(0.060 \text{ m})$$

$$= (0.245 \text{ kg} \cdot \text{m}^2) \alpha$$

$$\alpha = -18.94 \text{ rad/s}^2$$

$$\alpha = 18.94 \text{ rad/s}^2 \curvearrowright$$

Vector Mechanics for Engineers: Dynamics

Sample Problem 16.10

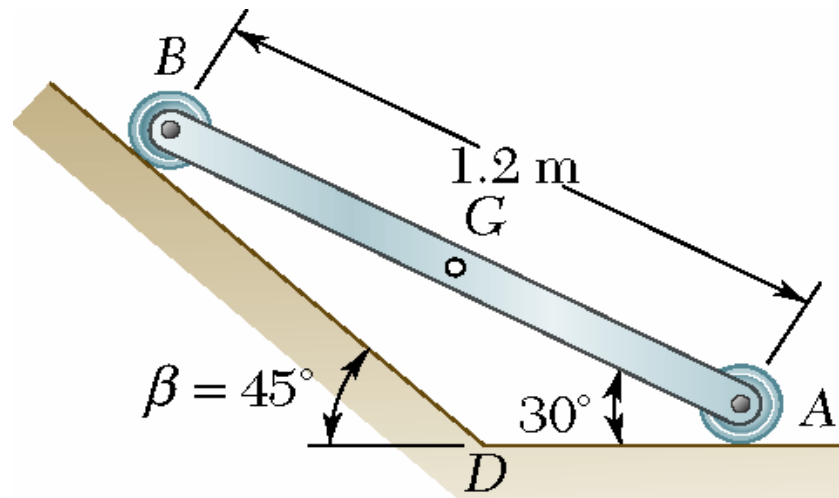

The extremities of a 1.2 m rod weighing 25 kg can move freely and with no friction along two straight tracks. The rod is released with no velocity from the position shown.

Determine: *a*) the angular acceleration of the rod, and *b*) the reactions at A and B.

SOLUTION:

- Based on the kinematics of the constrained motion, express the accelerations of A, B, and G in terms of the angular acceleration.
- Draw the free-body-equation for the rod, expressing the equivalence of the external and effective forces.
- Solve the three corresponding scalar equations for the angular acceleration and the reactions at A and B.

Vector Mechanics for Engineers: Dynamics

Sample Problem 16.10

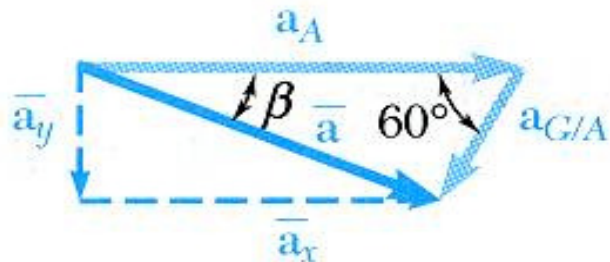
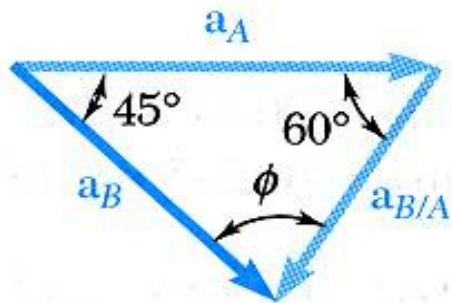
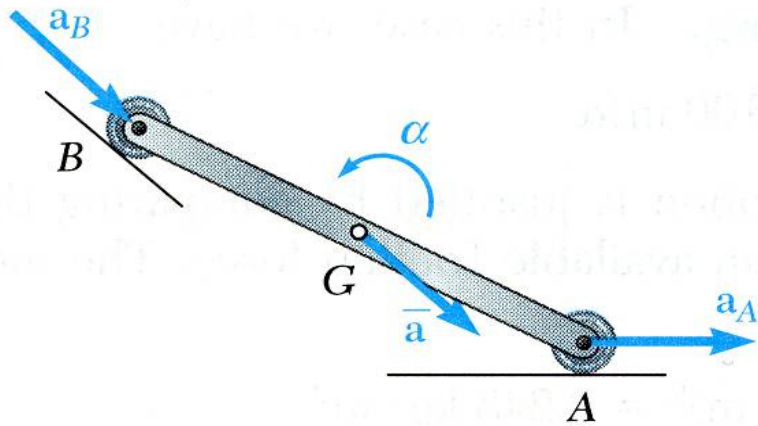

SOLUTION:

- Based on the kinematics of the constrained motion, express the accelerations of \$A\$, \$B\$, and \$G\$ in terms of the angular acceleration.

Express the acceleration of \$B\$ as

$$\vec{a}_B = \vec{a}_A + \vec{a}_{B/A}$$

With \$a_{B/A} = 4\alpha\$, the corresponding vector triangle and the law of signs yields

$$a_A = 5.46\alpha \quad a_B = 4.90\alpha$$

The acceleration of \$G\$ is now obtained from

$$\vec{a} = \vec{a}_G = \vec{a}_A + \vec{a}_{G/A} \quad \text{where } a_{G/A} = 2\alpha$$

Resolving into \$x\$ and \$y\$ components,

$$\bar{a}_x = 5.46\alpha - 2\alpha \cos 60^\circ = 4.46\alpha$$

$$\bar{a}_y = -2\alpha \sin 60^\circ = -1.732\alpha$$

Vector Mechanics for Engineers: Dynamics

Sample Problem 16.10

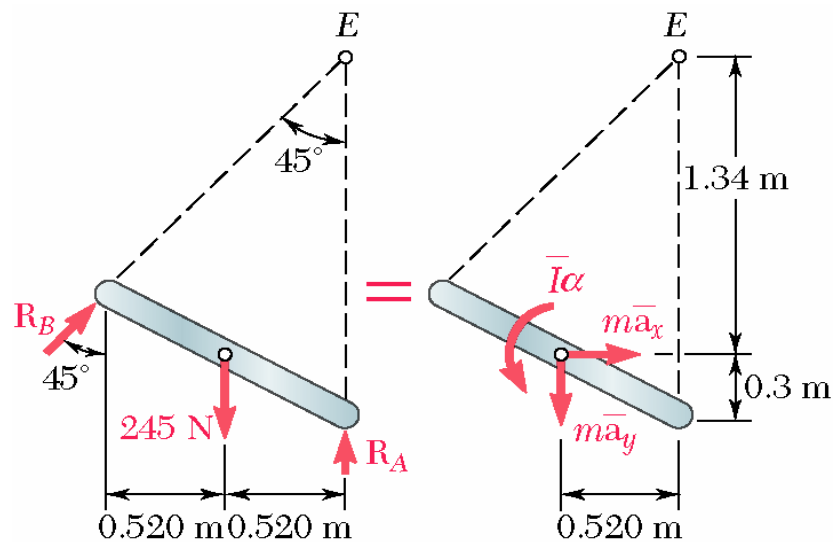

- Draw the free-body-equation for the rod, expressing the equivalence of the external and effective forces.
- Solve the three corresponding scalar equations for the angular acceleration and the reactions at A and B.

$$\begin{aligned}
 +\curvearrowright \sum M_E &= \sum (M_E)_{eff} \\
 (25)(0.520) &= (33.5\alpha)(1.34) + (13.0\alpha)(0.520) + 3\alpha \\
 \alpha &= +2.33 \text{ rad/s}^2
 \end{aligned}$$

$$\alpha = 2.33 \text{ rad/s}^2$$

$$\begin{aligned}
 \bar{I} &= \frac{1}{12} ml^2 = \frac{1}{12} \frac{25 \text{ kg}}{12} (1.2 \text{ m})^2 \\
 &= 3 \text{ kg}\cdot\text{m}^2
 \end{aligned}$$

$$\bar{I}\alpha = 3\alpha$$

$$m\bar{a}_x = \frac{25}{12} (1.34\alpha) = 33.5\alpha$$

$$m\bar{a}_y = -\frac{25}{12} (0.520\alpha) = -13.0\alpha$$

$$+\rightarrow \sum F_x = \sum (F_x)_{eff}$$

$$R_B \sin 45^\circ = (33.5)(2.33) = 78.1$$

$$R_B = 110 \text{ N}$$

$$\vec{R}_B = 110 \text{ N } \nearrow 45^\circ$$

$$+\uparrow \sum F_y = \sum (F_y)_{eff}$$

$$R_A + (110 \text{ N}) \cos 45^\circ - 245 = -(13.0)(2.33)$$

$$R_A = 137 \text{ N } \uparrow$$