

Guide to Sustainable Design

Using SolidWorks Sustainability

Contents

About the Contributors	3
Chapter 1: Introduction and Terminology	5
Why should you read this guide?	5
How should you use this guide?	6
Chapter 2: Sustainability and the Design Professional.....	8
Definitions of “sustainability”	8
Scope of sustainability.....	8
Sustainable company	10
The many faces of sustainable design	11
Your influence is critical	13
Chapter 3: Making Theory Matter – Initial Analysis Decisions	15
A sustainable design challenge	15
Environmental impact assessment tools & techniques.....	15
Choice 1: Environmental Indicators.....	19
Choice 2: Scope.....	23
Choice 3: Metrics.....	31
Chapter 4: Putting It All Together.....	38
Intuition	38
Product scorecards.....	39
Conceptual Life Cycle Thinking.....	41
Qualitative Matrix Life Cycle Assessment.....	42
Life Cycle-Based Design Assessment.....	44
Life Cycle Assessment.....	46
So what? (Using the results of your assessment tool)	51
Chapter 5: A Redesigned Cup – Priscilla’s Challenge	53
Chapter 6: A Reconsidered Toy – Tom’s Turn	68
Chapter 7: The Sustainable Design Strategies	78
Impact Level and Scope.....	78
Optimizing an Existing System.....	80

Altering an Existing System.....	81
Quantity and Quality	82
Chapter 8: Communicating the Results	84
To designers and engineers unfamiliar with sustainable design	84
To general management	84
To other parts of the supply chain.....	85
To sales & marketing.....	86
Chapter 9: Next Steps	88
Chapter 10: For More Information	90
Appendix A – Reference materials.....	90
Appendix B – A deeper look at the LCA process.....	91
Appendix C – LCA Tools and Methods.....	101

About the Contributors

[Alphabetical by Affiliation]

Rudy Ruggles

Collaborative Innovation Services, LLC



Rudy Ruggles is the President of Collaborative Innovation Services, LLC, a consultancy helping organizations use the tools and principles of sustainability to create innovative solutions to strategic and organizational challenges. His work combines his 20 years of professional experience working with clients in multiple industries to enhance their organizational learning, knowledge management, and innovation capabilities with his expertise in environmentally and social responsible business practices, particularly as they apply to product design and development.

Along with his client work in this area and an MBA from the Kellogg School at Northwestern University, he has earned a Certificate in Sustainable Design from the Minneapolis College of Art & Design.

Asheen Phansey

DS SolidWorks Corporation



Asheen Phansey joined SolidWorks in 2010 as product manager for SolidWorks Sustainability and all-around sustainability advocate for the company. His expertise in nature-inspired design, product lifecycle stewardship, closed-loop business models, and green marketing has been built through a career in technology, business and academia.

Asheen travels widely speaking on sustainable innovation around the world and teaches MBA courses in Sustainable Entrepreneurship and Green Marketing as an Adjunct Professor at Babson College. Prior to SolidWorks, Asheen founded the consultancy Quaking Aspen to help companies develop sustainable innovation toolkits, building on his years of innovation experience in the biotech, software, and aerospace industries.

Asheen holds a BS in Chemical Engineering from Cornell University and an MBA from Babson College, and has received a certificate in nature-inspired design from the Biomimicry Institute.

Benjamin Linder

Olin College of Engineering



Dr. Benjamin Linder is an Associate Professor of Design and Mechanical Engineering at Olin College of Engineering, where his teaching and research efforts are focused on sustainable design, international development, human centered design and creative design methods. These efforts are directed at developing techniques and approaches that further a more ecologically connected and socially informed design practice.

As an experienced teacher and practitioner of product design, Linder regularly advises and delivers workshops for practitioners, educators and the Public. He is a co-organizer of the International Development Design Summit that brings people together from over 20 countries to build local, creative design capacity.

Dr. Linder received a B.S.E. in Mechanical Engineering and a B.S.E. in Electrical Engineering from the University of Michigan where he studied engineering design with Professor Panos Papalambros. He received his M.S. and Ph.D. in Mechanical Engineering from the Massachusetts Institute of Technology where he studied product design and design education with Professor Woodie Flowers.

Chapter 1: Introduction and Terminology

The idea of “Sustainable Design” is cropping up more and more in today’s product design conversations. But what *is* sustainable design, and how do I do it? We hope to answer this question throughout this Guide.

Why should you read this guide?

There are probably as many reasons to read this guide as there are people reading it. That said, design engineers will want to incorporate sustainability principles into their work for at least one of four general reasons.

Personal interest

Many people are drawn to sustainable design because they want to use their talents and expertise to make the world a better place. As naïve as that sentiment might seem, it is a powerful driver behind a great deal of innovation and creative engineering. And, given the state of the world today, we could use all the help we can get.

Professional growth

Sustainable design is becoming a growth area, with many companies needing designers and engineers who have experience incorporating environmental impact considerations into product development. In fact, *Forbes* magazine included Industrial Designer in its list of ten “six-figure green jobs,” going on to say that “postings for environment-related jobs on TheLadders.com, a job search site for \$100,000-a-year and more jobs, have increased by 25% over the past year.”¹ Even if it’s not the central pillar of a designer’s job, it will increasingly become a standard component of the design process, so it’s best to get ahead of the curve.

Company intent

Many readers may be here not because of their own interest, but because sustainable design is part of a company initiative. Whether driven by stockholders, customers, or senior leadership, “sustainability” is increasingly on corporate agendas. While social and environmental responsibility is often at the root of such efforts, many companies are also finding that sustainable design is just “good business.” Through it, companies find new ways to decrease material and energy costs, and increase revenue through resulting new product innovations.

Industry regulations

In many markets, regulations restrict the use of certain materials in products manufactured and sold there. For instance, in the European Union the Restriction of Hazardous Substances (RoHS) directive places strict guidelines on the use of specific materials in the manufacture of various

¹ http://www.forbes.com/2008/10/16/sixfigure-green-jobs-lead-corporations08-cx_avb_1016jobs.html

electronics. Because this directive applies to products imported to, as well as made in, the EU, it impacts manufacturers worldwide. While adhering to sustainable design principles doesn't necessarily assure compliance with such directives, these practices do support increased attention to exactly the issues that such regulations are intended to address, such as the toxicity of certain substances.

Whether you are learning about sustainable design and engineering because you *want* to be, or because you *need* to be, this guide will help you develop a better understanding of the topic, along with the tools and techniques that will enable you to design more environmentally responsible products.²

How should you use this guide?

First, feel free to jump around. This guide was made to be consumed in parts, and in no particular order. We'll build some terminology early on, so if you find concepts that you're unfamiliar with, navigate to the appropriate section to learn more. Going through the entire Guide—and playing with some of the examples—should take about 5-7 hours, so it's a good idea to pace yourself (or skip to the good parts).

Second, we don't require that you have a copy of SolidWorks Sustainability, or even SolidWorks, handy—we've designed this Guide to be interesting and informative (we hope!) without having access to our design software. However, we've also included examples that you can download into your copy of SolidWorks to make the theory come alive. As you go through the Guide, you'll be alerted to such examples by one of the following two boxes:



This box indicates a model that you can download and open in SolidWorks, and play with using SustainabilityXpress, which is automatically included with each SolidWorks version starting with SolidWorks 2010. You can also download SustainabilityXpress from SolidWorks Labs into SolidWorks 2009, by clicking [this link](#). SustainabilityXpress can be used with SolidWorks parts.

The *SustainabilityXpress* icon means that anyone who has SolidWorks 2009 or higher can work this example.

² Throughout the guide, the term “product” is used to describe the object being designed, whether an actual consumer product, machined part, piece of equipment, or other component or assembly.



This box indicates a model that you can download and open in SolidWorks, and play with using the full Sustainability tool, if you have purchased this add-in. SolidWorks Sustainability can be used with SolidWorks parts and assemblies.

The *Sustainability* icon means that only those who have the full Sustainability product can work this example.

Chapter 2: Sustainability and the Design Professional

This section describes what is meant by “sustainability” and what you need to know about this concept. It starts out broadly, outlining why sustainability is important to the world, then what it means in the context of business, and finally why it is important in your role as a designer, engineer, product specialist, or other type of product design professional.

Definitions of “sustainability”

Sustainability can be quite a malleable term. While most people understand its intention intuitively, it’s difficult to actually pin down since it can cover so many domains. The World Commission on Environment and Development, known more popularly as the Brundtland Commission, created one of the best-known and often used definitions:

*Sustainable development is development that meets the needs of the present without compromising the ability of future generations to meet their own needs.*³

The Natural Step, in another widely-adopted framework, goes on to lay out four system conditions, derived from the laws of thermodynamics, through which such a state can be achieved:

In a sustainable society, nature is not subject to systematically increasing...

- 1. concentrations of substances extracted from the Earth’s crust,*
- 2. concentrations of substances produced by society,*
- 3. degradation by physical means*

and, in that society. . .

- 4. people are not subject to conditions that systemically undermine their capacity to meet their needs*⁴

Scope of sustainability

As can be seen in the definitions above, sustainability represents a balanced interaction between the human-built and natural worlds. This interaction is often expressed as having three components: environment, social equity, and economy. The relationship between each of these elements is often represented as either a Venn diagram, with sustainability at the intersection,

³ Our Common Future, Report of the World Commission on Environment and Development, World Commission on Environment and Development, 1987. Published as Annex to General Assembly document A/42/427, Development and International Co-operation: Environment August 2, 1987.

⁴ <http://www.naturalstep.org/the-system-conditions>

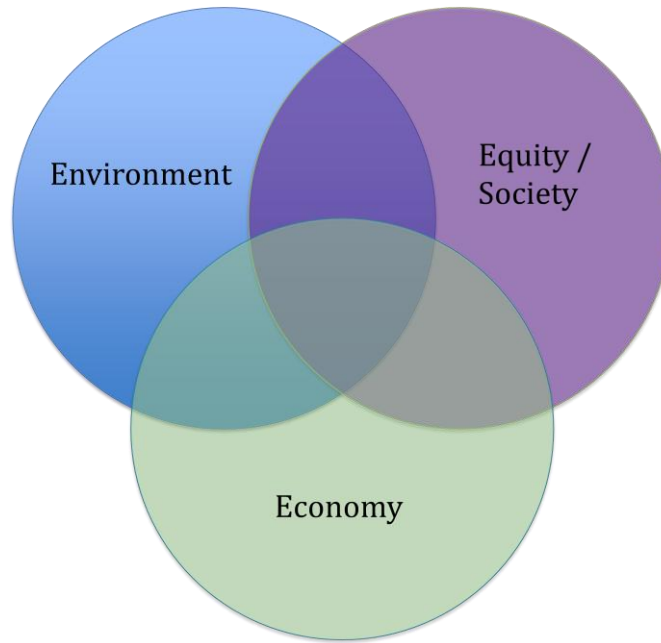

or as concentric circles, reflecting a layering of domains. This second case reflects the more realistic perspective that a healthy economy depends on a healthy society, both of which rely on a healthy environment. Sustainability occurs when all three are thriving.

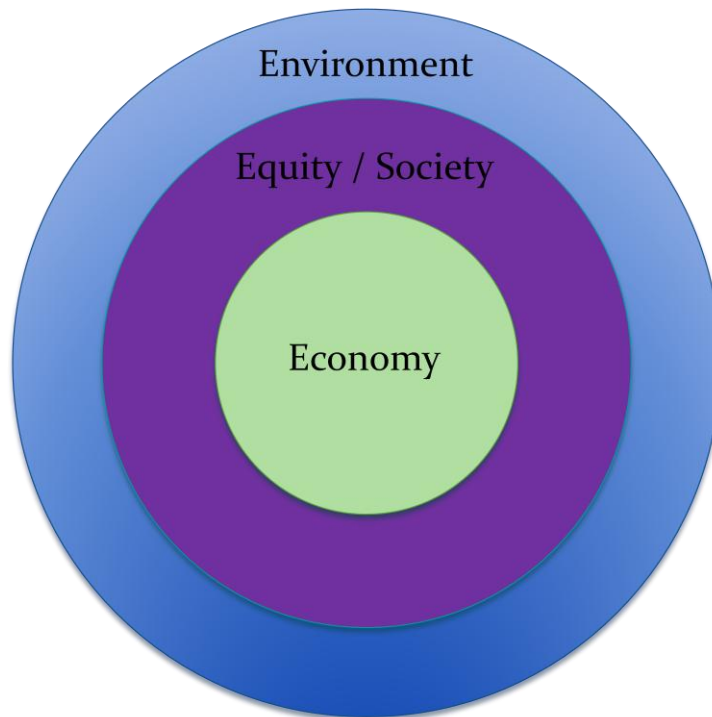

Sustainable company

Sustainable companies reflect the same balance of economic, social, and environmental responsibility. They exist as business entities, but are a part of a system that relies on a healthy dynamic of man-made and natural elements. At their most basic level, businesses take inputs, process them (adding value), and generate outputs. That gives us the ideal of a truly sustainable company to strive for:

A truly *sustainable* company is one that:

- Uses the waste of other processes as its input, and minimizes or eliminates the use of virgin materials extracted from the earth;
- Creates output that can be used by other processes or returned to a natural state, and eliminates waste that can't be used or returned to a natural state;
- Uses the least amount of energy to achieve the desired outcome, and uses energy ultimately derived from renewable sources.

The value companies generate has traditionally been measured in purely financial metrics. However, it is becoming more common to reflect the value generated as a “triple bottom line.” Whether represented formally as a Corporate Social Responsibility report or more informally, companies interested in being sustainable now focus on the triple bottom line of people, planet, *and* profit.

Sustainability manifests itself in companies at a variety of levels, including:

- **Strategy** – Some companies decide what to make or do based on sustainable business ideals. Stonyfield Farms has made social and environmental responsibility a key part of its business strategy since it began.
- **Supply chain & value webs** – Walmart requires its suppliers to evaluate and disclose the full environmental impact of their products. There continues to be increased attention to so-called industrial ecology, which analyzes the material and energy flows within whole industrial systems, often extending far beyond the domain of a single business.
- **Operations** – Decisions about how to make and move products increasingly reflect environmental impacts. In the case of the floor covering company Interface, what has become one of the real sustainable business success stories started with rethinking the social and environmental impacts of their operations.⁵ In many cases, companies have instituted Environmental Management Systems (EMS), which have operationalized the tracking, documentation, and reporting of environmental impacts by the business. There is even a specific ISO standard (ISO 14001:2004) governing EMS.
- **Product development & design** – Companies have incorporated sustainability into their new product development process in ways ranging from specifically creating “green” products (e.g., Brooks’ Green Silence shoe, with its BioMoGo biodegradable midsole) to the

⁵ For more on Interface, see <http://www.interfaceglobal.com/Sustainability.aspx>

reduction of the environmental impact of its “regular” products (e.g., Apple’s use of a recyclable aluminum enclosure for its Mac Pro computer).

The majority of this guide will focus on product-level sustainability considerations, but it’s helpful to keep in mind that sustainability isn’t the domain of just one part of the business. In fact, a truly sustainable product can only exist within the context of a much broader system that supports its positive impact on people, planet, and profit.

The many faces of sustainable design

Now that you have a bit of background on *sustainability*, let’s talk about *sustainable design*. Sustainable design is the term we’ve chosen to represent the intelligent application of the principles of sustainability to the realm of engineering and design. This guide focuses on products and similar manufactured components, but the same principles can also apply to architecture, civic planning, and other realms of the “built.”

Furthermore, “sustainable design” is just one term used to describe the use of sustainability principles in the design and development of commercial and industrial products. Other often-used terms include sustainable engineering, environmentally sustainable design, eco-design, and green design. All are essentially synonymous for most purposes.

There are however several terms related to this topic that have distinct meanings. Designers interested in sustainability-focused tools and techniques will find these concepts useful to at least know about, if not incorporate in their work.

Design for Disassembly

Sometimes shortened to DfD, this is a design approach that enables the easy recovery of parts, components, and materials from products at the end of their life. Recycling and reuse are noble intentions, but if a product cannot be disassembled cleanly and effectively they are impossible, or at least cost prohibitive to achieve.

If you’d like to learn more about DfD, there’s a really great set of [Design for Disassembly Guidelines](#) (PDF) produced by Active Disassembly Research Ltd., and a similar set of rules and case studies for building produced by the City of Seattle (WA, USA) and others called [Design for Disassembly in the Built Environment](#) (PDF).

Design for the Environment

The U.S. Environmental Protection Agency created the Design for the Environment (DfE) program in 1992 to decrease pollution and the human and environmental risks that it entails. It recognizes consumer and industrial & institutional products deemed to be safer for human health and the environment through an evaluation and product labeling program. Furthermore, the program defines best practices in a variety of industries, and identifies safer chemical alternatives.

You can learn more at EPA's DfE website, <http://www.epa.gov/dfe/>.

Product stewardship

Also known as extended product responsibility (EPR), this approach is based on the principle that all those involved in the lifecycle of a product should share responsibility for reducing its environmental impact. It often results in voluntary partnerships among manufacturers, retailers, government, and non-government organizations to set up effective waste-reduction systems and practices. For instance, the U.S. Environmental Protection Agency's Product Stewardship program "has primarily focused on end-of-life considerations as one means of encouraging more environmentally conscious design and greater resource conservation. However to address the full range of product lifecycle issues, the Product Stewardship program also works with other EPA programs, as well as various public- and private-sector stakeholders, to promote 'greener' design, greener product standards, and greener purchasing practices."⁶

Again, you can learn more about this concept at EPA's dedicated website, <http://www.epa.gov/epr/>.

Cradle to Cradle

William McDonough and Michael Braungart popularized the notion that product lifecycles should be considered not as cradle to grave, but as cradle to cradle. The key idea here is that there is no such thing as a "grave" at the end of use, since everything goes somewhere. As they say, there is no such thing as "away." Given that, in order to be sustainable all of the elements of a product that has reached the end of its useful life should be designed to go somewhere where it can serve as the input to another system, a concept often characterized as "waste = food." While product development processes may focus on cradle to gate, cradle to grave, or even gate to gate plans, effective lifecycle planning needs to find ways to close all possible loops.

Learn more about the concept from McDonough and Braungart's coauthored book *Cradle to Cradle: Remaking the Way We Make Things* ([amazon link](#)), and from the [dedicated C2C page](#) on their for-profit company's website.

Biomimicry

Nature has spent millions of years developing some very interesting and effective solutions to a wide range of design challenges. Biomimicry is "the practice of designing materials, processes, or products that are inspired by living organisms or by the relationships and systems formed by living organisms."⁷ Such inspiration comes in two forms, as either "challenge to biology" or "biology to challenge." In the first case, a design challenge exists and designers search nature for potential solutions. The second case entails starting with an interesting biological property that researchers or scientists attempt to apply more broadly or commercialize. Note that just because a

⁶ <http://www.epa.gov/osw/partnerships/stewardship/basic.htm>

⁷ Asheen Phansey, "Biomimicry," *Berkshire Encyclopedia of Sustainability: The Business of Sustainability* (New York: Berkshire Publishing Group, 2009), p. 37.

solution is based on nature doesn't mean that it's inherently healthy or sustainable. For instance, nature has created plenty of toxic substances that could be extremely harmful if misapplied.

Read more about this science, and the work of some “biomimics”, by picking up a copy of Janine Benyus' book *Biomimicry: Innovation Inspired by Nature* ([amazon link](#)) or by visiting the website of the not-for-profit [Biomimicry Institute](#).

Green chemistry

Green chemistry focuses on reducing the generation and use of hazardous chemicals, decreasing pollution at its source. Paul Anastas and John Warner published the 12 Principles of Green Chemistry in 1998 and set out the following design goal:⁸

Chemical products and processes should be designed to the highest level of this hierarchy and be cost-competitive in the market.

1. Source Reduction/Prevention of Chemical Hazards
2. Reuse or Recycle Chemicals
3. Treat Chemicals to Render Them Less Hazardous
4. Dispose of Chemicals Properly

Learn more about Green Chemistry by reading Anastas and Warner's coauthored book, *Green Chemistry: Theory and Practice* ([amazon link](#)), or by visiting the website of Dr. Warner's for-profit company, the [Warner Babcock Institute for Green Chemistry](#).

Green marketing

Many companies find that promoting the environmental responsibility, or even just the benefits, of their products can be a powerful marketing angle. Touting the “green” aspects of existing products, processes, or systems has become almost the standard in many industries. Some companies' messages actually outstrip their reality, leading to what is generally called “greenwashing.” As will be discussed later in the guide, there are now quite strict guidelines issued by the Federal Trade Commission about making “green” claims. When talking with sales and marketing people in their company, product designers will find it helpful to know what benefits of their sustainable design and engineering efforts can be claimed publicly.

Learn more about Green Marketing by viewing this [short video](#) on the topic produced for Sustainable Life Media's SustainableBrands Boot Camp, or view the FTC's Green Guides and related resources at <http://www.ftc.gov/opa/reporter/greengds.shtm>.

Your influence is critical

In the midst of the myriad sustainability tools, techniques, global and local activities, and corporate initiatives the product designer plays a key role. This person has an impact in the pivotal stage where decisions are made about what inputs are needed, how they must be

⁸ *Green Chemistry: Theory and Practice*, Oxford University Press (1998)

processed, what the product’s lifecycle looks like, and what its end of life looks like. Engineering for sustainability early in the design process creates a trajectory that can lock in the benefits from the beginning, whereas leaving environmental impact considerations for later stages creates costly clean-up and accommodation efforts. For instance, a product designed for easy disassembly requires much less effort to convert into recyclable and reusable components than one designed as a single module requiring energy-intensive end-of-life processing. The following graph reflects the advantages of making sustainability a priority as early in the design process as possible.⁹

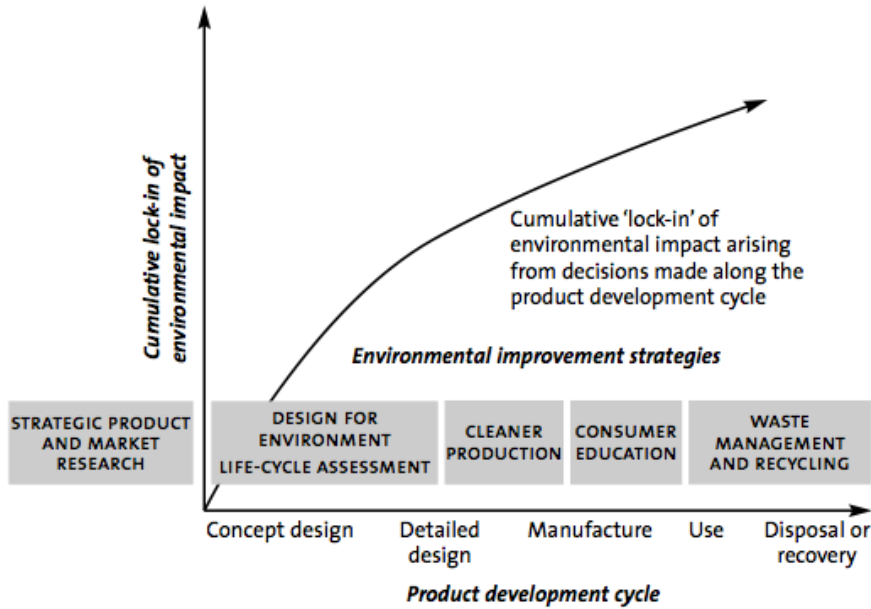

There are obviously many decisions affecting sustainability over which design engineers have little or no influence. For instance, it’s usually not solely up to the designer where a component is manufactured, what transportation modes will be used to deliver it to customers, what materials suppliers use, and so on. Even so, what engineers can do to influence a product’s environmental impact has far-reaching implications. In his book *The Total Beauty of Sustainable Products*, Edwin Datschefski writes, “Design is the key intervention point for making radical improvements in the environmental performance of products. A 1999 survey by Arthur D. Little revealed that 55 per cent of senior executives in industry singled out design as the most important mechanism for their companies to tackle sustainability.”¹⁰ Along with influencing the product development process, it is often the designer’s identification of a more responsible choice that can cause changes in other areas towards creating a more sustainable company overall.

⁹ *Design + Environment: A Global Guide to Designing Greener Goods*, Greenleaf Publications (2001), p. 14

¹⁰ *The Total Beauty of Sustainable Products* - Edwin Datschefski, RotoVison SA, Switzerland, 2001

Chapter 3: Making Theory Matter – Initial Analysis Decisions

A sustainable design challenge

Let's start off with an example—something you can look at from all angles, at least virtually. We'll also introduce a character to champion this example.

Our first protagonist is a producer of paper and plastic products for the public, whose name is Priscilla. Her story illustrates many of the concepts we'll be up against.

Priscilla was tasked with a seemingly straightforward question:

How can we make our disposable drinking cups greener?

Priscilla's first thought, especially given her background as a polymer engineer, was that this was going to be a game to find the least-impactful plastic polymer with the desired properties... but we're getting ahead of ourselves.

First, here's a picture of the cup in question that Priscilla was starting with:

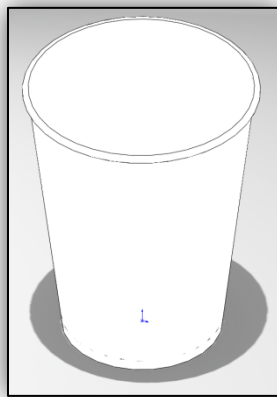

Now, let's get down into the details of what environmental impact assessment looks like. We'll see that examining the environmental impacts of this cup was anything but simple.

Environmental impact assessment tools & techniques

Sustainable design is relative

First, you'll notice we said we wanted a **greener** drinking cup. There is no such thing as a "sustainable" or "green" product, only a *more* sustainable or greener one. In fact, a green product is

one that's never made -- the most sustainable solution is to avoid making unnecessary items altogether.

When Priscilla learned the “Sustainable design is relative” concept, she stopped to think about her product. Were disposable drinking cups really necessary? Shouldn't Priscilla be encouraging her consumers to use reusable cups instead? That was fine in theory, but reusables were made in another division and in another country. So, thought Priscilla, let's try to make the best disposable drinking cup we can, and revisit the deeper product redesign later. After all, even if Priscilla succeeded in encouraging her customers to buy reusables, they weren't going to stop buying disposable cups overnight.

For those products that we've decided are necessary, everything has impacts of some sort. The basic purpose of sustainable design is to find ways to reduce those impacts, and by doing so find a *more* sustainable solution. This section describes ways to determine what “more sustainable” looked like for Priscilla.

What am I comparing?

Priscilla's next thought was: “more sustainable than *what?*”

Designers who want to decrease a product's environmental impact need to have some way of evaluating what difference their choices make. The only way to evaluate whether a design is *more* sustainable is to see how its impacts compare with other options, such as an alternative design, a previous version, a benchmark, or an impact goal.

Throughout this guide, the term *product* has been used to describe the object of the designer's work. When it comes to determining environmental impact, it's important to specify a unit of analysis. Relative comparisons only work if there is a common basis. In some cases this might be quite straightforward, such as when it's two generations of the same design or when faced with a simple material substitution. However, in most redesign opportunities, it's necessary to specify a common “product unit” for the analysis.

An often-used way of handling this is to identify a *functional unit*. Instead of looking at a product as an item, it can be seen as a way for a certain function to be performed. In order to compare two different product systems, it's necessary to choose a measure of the function of the systems that is consistent between the two. For instance, for a coffee maker it might be cups brewed, for laundry detergent it could be washing cycles, for paint it could be surface protection over time. This way, it's possible to assess the impact of various ways to perform a specific function, without being constrained by differences in the forms of the designs.

“Well, that’s easy,” thought Priscilla. “My cup’s purpose is to hold liquid.” But when she thought about all the products designed to hold liquid -- detergent bottles, soda cans, mop buckets -- Priscilla realized she had to narrow down this purpose to define the functional unit. She decided that her cup’s *functional unit* was sixteen ounces or about 500 mL of (cool) liquid that could be poured in or out—or even better, 1600 ounces, equaling the volume of a pack of 100 cups. Now she could compare her bag of cups with all the other products imaginable that could hold this amount of cool liquid (and pour it in and out) and find the most sustainable option.

What am I measuring? The Three Choices of Environmental Assessment

Product sustainability is not only relative, it’s multidimensional. There is no single, universal indicator of sustainability (no, not even carbon). The appropriate impact metrics and dimensions on which products are compared can differ significantly, depending on the purpose of the evaluation. Impact measurement creates the key dashboard for sustainable design, so it’s important to choose an assessment approach that will generate information consistent with its intended use.

The appropriate technique for evaluating the environmental impact of a design depends on the answers to the following three questions:

1. **What impacts do you care about?** Does toxicity matter? Water use? Only CO₂ equivalents?
2. **What is the scope of the assessment?** How far up and down the supply chain does it go? How much of the product’s lifecycle should it reflect? What is the unit of analysis for the assessment? Is it for a component, an assembly, a product, a system?
3. **What types of metrics are appropriate for your purposes?** What will the assessment information be used for, and by whom? Is rigorous detail necessary, or is a “rough idea” good enough?

The following figure lays out these choices graphically, using examples of some of the impacts, scope elements, and metrics that might be used. The sections that follow will explore each of these elements in more depth and give examples of the kinds of assessment techniques appropriate at each level.

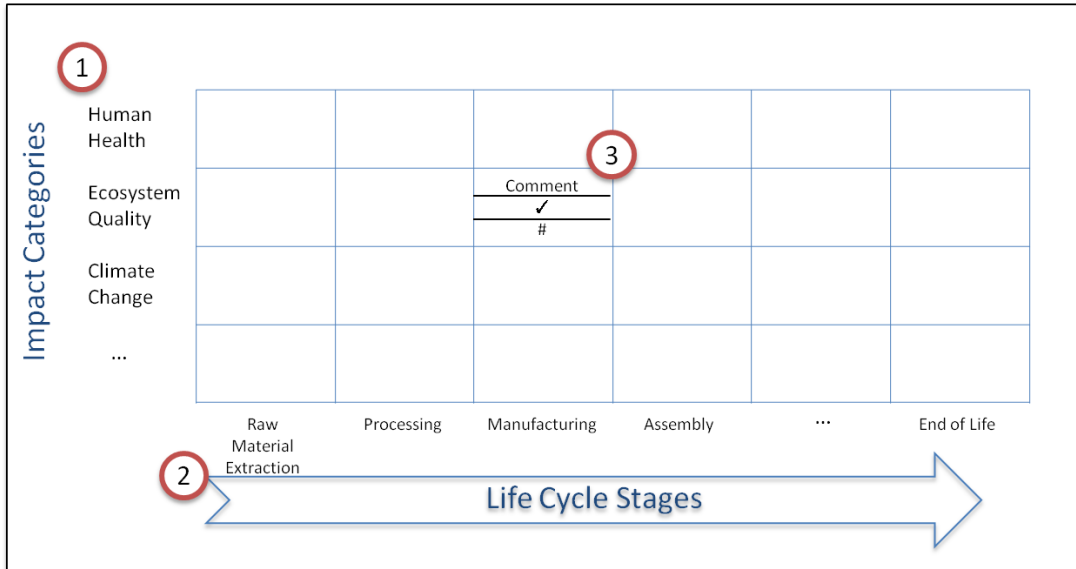

“This is pretty intense,” thought Priscilla. “I’m going to call up my friend Tom and talk to him about sustainable engineering and my little cup. Maybe Tom has been through this process before.”

As luck would have it, Tom was going through an identical exercise with a product of his own. Tom is a tinkerer of tiny toys for tots and toddlers, and now he was toying with the idea of making a greener holiday gift for his wee customers.

Here’s the toy that Tom showed Priscilla:

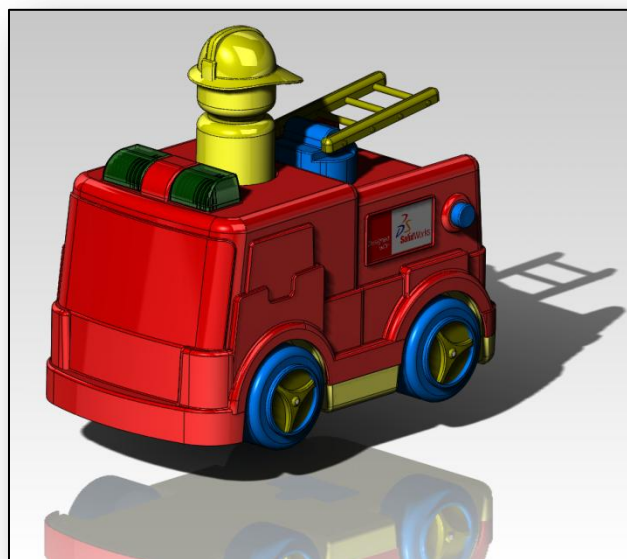

“It’s a pretty simple toy,” Tom told Priscilla. “The child pushes it around, and at the push of the button, the lights flash and the siren sounds. They can also pull the fireman out of the truck.”

“I had to think for a while about the functional unit that I was using for environmental comparisons,” continued Tom. “After all, this toy is clearly more impactful than other toys—say, some simple plastic blocks of similar size. After all, my toy uses a battery. But I’ve noticed that my own kids will play with a toy a lot longer if it *does* something—like having flashing lights. So I decided that my functional unit was a children’s toy with interactive components, which can be played with on the floor. So my question is:

“How can I make a greener children’s toy?”

“I’m at the stage now where I’m making my three measurement choices,” Tom finished. Perfect, thought Priscilla.

Choice 1: Environmental Indicators

There are a wide range of environmental impacts that can be assessed. However, it’s not always necessary to try to cover many, or even some, of these impacts if you’re mainly interested in one impact measure, or *environmental indicator*. For instance, there’s a lot of attention on greenhouse gas (GHG) emissions these days, due to their association with climate change. If the carbon footprint resulting from these emissions is the only impact your organization or your customers are focused on, it would be unnecessary to spend time assessing impacts on such things as air quality or human toxicity; measuring your product’s carbon footprint would suffice. So, step one is to determine which impacts should be measured based on the purpose of the assessment and how its data will be used.

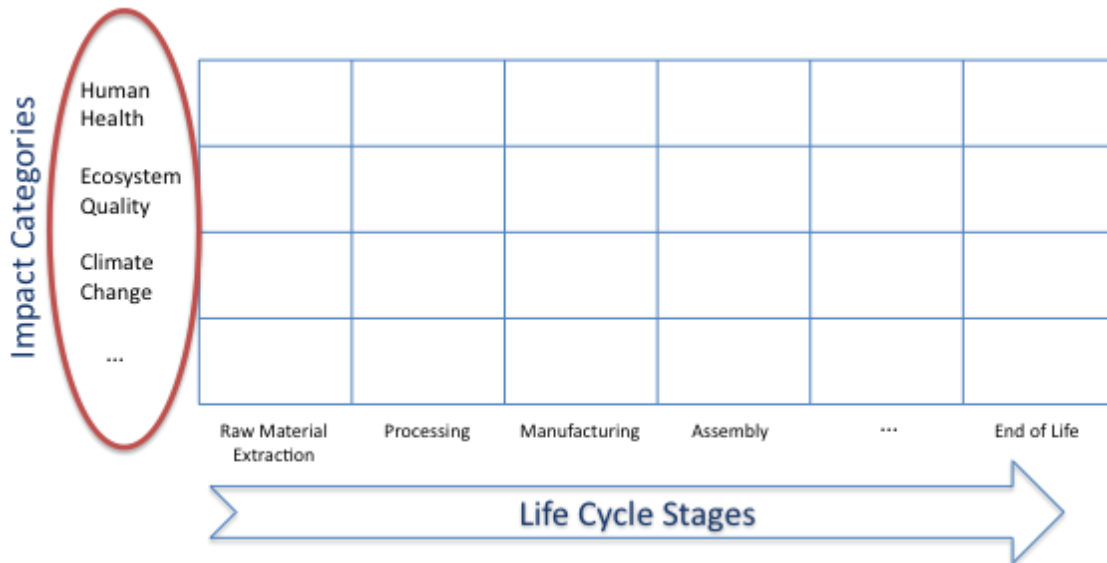

Five Categories of Impact

How to choose among the dozens of different types of environmental impacts? We'll start with grouping some commonly used environmental impact categories into five major domains:

1. natural resource depletion,
2. air impacts,
3. terrestrial & aquatic impacts,
4. climate effects, and
5. human health.^{11 12}

This section will describe these different environmental effects that Priscilla and Tom can choose to measure.

Natural Resource Depletion

This first domain reflects the many ways human activity uses up the Earth's natural resources. "Depletion" means that those resources are no longer available for further use in their highest-value forms.

Water Use

A water "footprint" primarily refers to the amount of fresh water being used or consumed which then must be processed back to its fresh state (water *quality* issues are covered by other impact categories). Water is the only resource that is both renewable and finite. All of the water that was ever on Earth is still on Earth, but the breakdown of its location, physical state (water, vapor or ice), and salinity can limit its usefulness as a resource. In fact, after oil, many people believe that water will become the resource with the most highly valued access rights, which has significant social and environmental-justice implications.

Mineral Extraction

Mineral deposits can't be renewed. Once a mineral deposit (like iron ore) is mined, it doesn't return to earth as ore, no matter how much it's reused or recycled. There's only a finite amount of each mineral, so any used now will not be available for future generations to mine.



the

Land Occupation/Use

Land can't be depleted, really (ground pollution is covered later), but since a given acre can only be used for a limited number of purposes, land scarcity can be a real issue. Land can also become unusable, or at least less valuable, due to physical changes such as erosion.

¹¹ Jolliet, O., Margni, M., Charles, R., Humbert, S., Payet, J., Rebitzer, G. and Rosenbaum, R., 2003. IMPACT 2002+: A New Life Cycle Impact Assessment Methodology. *Int J LCA* 8 (6), 324-330. [Article](#)

¹² Adapted from "Life Cycle Assessment: Principles and Practice," Scientific Applications International Corporation, EPA/600/R-06/060 (May 2006), pg. 49.

A decrease in available land can impact a wide variety of systems, including agriculture, civilization, and biodiversity – the amount and variety of life that the land can support.

Non-Renewable Energy

While there are a variety of non-renewable natural resources used for energy, the ones that usually get the most attention are oil, coal, and natural gas. This non-renewable energy impact includes the energy (electricity or fuels) used during the product's manufacture and use, and can even go one step further to include the upstream energy required to obtain and process the energy consumed in the product's lifecycle. Efficiencies in energy conversion (e.g. power, heat, steam, etc.) can also be factored in. The non-renewable energy demand can also include a measure of the embodied energy of the materials—that is, the energy that would be released if the product were burned.

Air Impacts

The Earth is wrapped in a layer of gases mixed in proportions necessary to sustain life on the planet. There are several ways humans affect those proportions, with far-reaching results. (Effects to the climate are included in a separate domain.)

Air Acidification

Burning fuels creates sulfur dioxide, nitrous oxides, hydrofluoric acid, ammonia, and other acidic air emissions. This causes an increase in the acidity of rainwater, which in turn acidifies lakes and soil. These acids can make the land and water toxic for plants and aquatic life, and can leach life-sustaining minerals from the soil. Acid rain can also slowly dissolve manmade building materials, such as concrete—or these statues seen here.



Photochemical Oxidation

Most people are very familiar with this impact--especially when it's called by its common name of "smog." Caused by the emission of air pollutants such as non-methane hydrocarbons, this effect results in decreased visibility, eye irritation, respiratory tract and lung irritation, and vegetation damage.

Ozone Layer Depletion

Not long ago, the holes growing in the ozone layer were the top environmental concern. While quick action has slowed, and in some cases reversed, the damage, ozone layer depletion is still a concern. Caused primarily by the emission of chlorofluorocarbons (CFCs), hydrochlorofluorocarbons (HCFCs), halons, and methyl bromide (CH_3Br), the thinning of the atmosphere's ozone layer allows increased ultraviolet radiation to reach the earth. This radiation can cause cancer in animals and decreased plant and algae viability.

Terrestrial & Aquatic Impacts

Several types of impacts directly affect land and water quality.

Water Eutrophication

Eutrophication occurs when an overabundance of plant nutrients are added to a water ecosystem. Nitrogen and phosphorous from wastewater and agricultural fertilizers causes an algal bloom (explosive growth of algae), which then depletes the water of dissolved oxygen—a situation known as hypoxia--resulting in the suffocation of aquatic life.

Aquatic Ecotoxicity

While eutrophication occurs due to an excess of nutrients, ecotoxicity results from the presence of poisons in the water. This is generally caused by chemicals being dumped or seeping into lakes and rivers. It results in decreased aquatic plant and insect production and biodiversity, as well as impacting water drinkability.

Terrestrial Ecotoxicity

Toxins present in soil cause decreases in wildlife and plant production and biodiversity. While some of these toxins may be introduced from airborne or aquatic sources, many are the result of direct human application or through leaching from industrial processes or waste accumulations.

Climate Effects

The global climate is the result of myriad interacting systems. In many ways all of the other impacts have some influence over the climate. However, one climate effect in particular has been identified as a key factor in shaping the future of life on Earth. Climate change, sometimes called global warming, is one of the most commonly identified impacts of interest.

Climate Change/Global Warming

Carbon dioxide (CO₂), methane (CH₄), and other so-called greenhouse gases resulting from burning fossil fuels accumulate in the atmosphere, trapping solar heat which in turn increases the earth's average temperature. A product's climate change impact is often referred to as its "carbon footprint" because global warming potential is usually measured in units of carbon dioxide equivalent (CO₂e). It is widely understood that global warming is the cause of such problems as loss of glaciers, extinction of species, soil moisture loss, changes in wind and ocean patterns, and more extreme weather, among others.

Human Health

While the other impact domains affect humans in many ways, they focus on the Earth's biosphere as a whole. This group of impact categories is human-centric.

Human Toxicity

Toxic chemicals released to the air, water, and soil enter the human body through breathing, ingestion, and through the skin. Whether cancer-causing agents (carcinogens), substances that can

cause birth defects (teratogens), or other pathogens, the net result is an increased likelihood of human sickness and other negative health effects.

Respiratory Inorganics

Many organic causes of respiratory problems are covered by some of the general environmental impacts already covered (e.g., photochemical oxidation). Respiratory inorganics are particulate matter, often resulting from the burning of fossil fuels emitting sulphate and nitrate aerosols. This particulate matter causes breathing difficulties.

Ionizing Radiation

Ionizing radiation is what most people are thinking of when they talk about radiation exposure. It is radiation that has enough energy to ionize atoms or molecules. Exposure can damage living tissue, resulting in cancer, radiation sickness, mutation, and even death.

The impact categories described above represent most of the major ones that you are likely to come across, although occasionally with different names or classifications. While all may seem important, each one requires data collection and reporting, which may or may not be feasible given the time and intention of the sustainability assessment. There are trade-offs in the value of including a broad range versus just focusing on one or two, a difference that multiplies depending on how many phases of the lifecycle fall within the assessment's scope.

Priscilla looked up from her scanning down the list of impact categories. “Well, they all seem pretty critical,” she said. “I think I’ll choose one indicator from each of the five domains: energy to capture resource use; acidification for the air; eutrophication for the water; carbon to measure climate change; and maybe human toxicity.”

“Not me,” said Tom. “I just read about the new [product carbon standard](#), and I’m betting that toys will start having carbon labels in the future. I want to get a sense of the carbon footprint of my toy, and figure out how to reduce it before we have to start reporting it to consumers. So that’s the indicator I’m interested in measuring and optimizing—just the carbon footprint of my fire engine.”

“Alright, what’s next, Priscilla?”

Choice 2: Scope

The second major consideration in assessing the sustainability of a product is the scope of analysis. For products, the scope is usually described by how much of its lifecycle is included in its impact assessment.

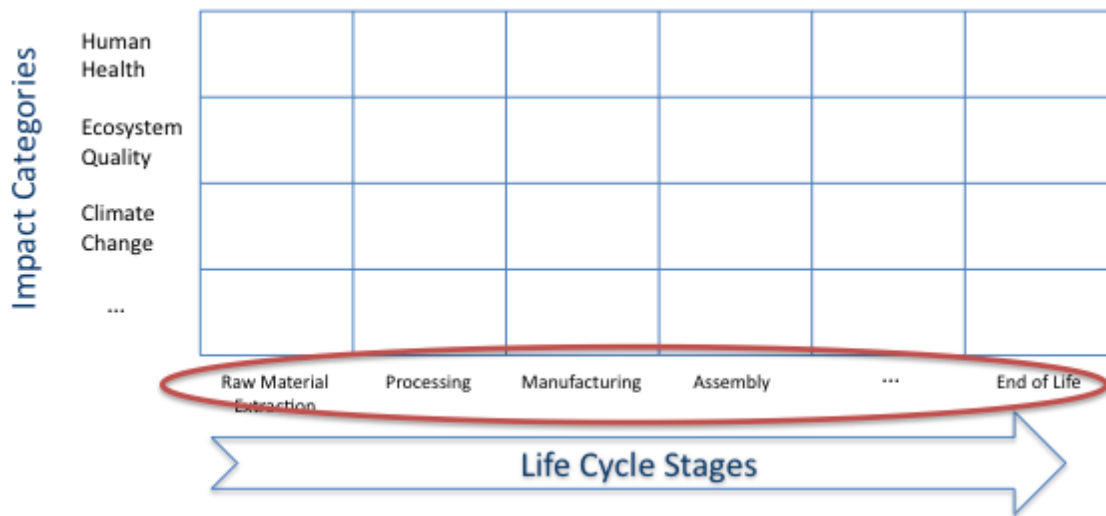

Lifecycle Phases

As with impact categories, there is not a single standard set of lifecycle phases, although there are certainly some that are most commonly used. In general, the full lifecycle of a product can be measured in five to seven phases:

Raw Material Extraction

This includes the energy and other resources used to acquire the basic materials used in the product, whether through mining ore, harvesting timber, extracting oil, etc. This phase can include harvesting materials from recycled sources if they are in the form of raw materials.

“My cup is plastic, so it starts with oil extraction,” said Priscilla.

“A lot of my toy does, too,” replied Tom. “But it also has some metal components, so that would include mining the ore.”

Material Processing

Raw materials are converted into forms used for manufacturing during this phase. It covers the processes required to make steel, copper, plastic feedstock, paper, gasoline, and the like.

“OK, so the oil for our plastics is then refined into the various hydrocarbon fractions to make the different plastic resins,” said Priscilla, idly sketching a distillation column.

“And the ores are refined into metals by melting or burning off impurities,” added Tom, wondering why Priscilla was sketching a missile silo.

Part Manufacturing

This phase covers single, or at least simple, part manufacturing. Common processes include injection molding, metal stamping and machining, weaving, and milling.

“My cup is made from PET plastic—polyethylene terephthalate. This is where the PET is injection-molded into a cup shape.”

“The plastic that makes up most of my toy is molded, too, but from ABS plastic. The siren sound comes from a little speaker component that I purchase; I’m not sure what’s in it, but I’m sure there’s a lot of copper, so I’ll just model it as a copper part. The spring is made of a steel alloy—probably regular carbon steel.”

Assembly

In many cases, products need to be assembled using processes that go beyond the creation of individual components. Because this is usually the first phase that brings together a disparate assortment of materials (e.g., a plastic handle and a metal container), environmental impact assessments significantly increase in complexity.

“I don’t really have any assembly steps,” said Priscilla, “since my cup is molded in a single pass from a single material.”

“I do have some assembly steps, but most of the parts just snap together. And of course, the battery is wired up to the siren and the lights.”

Product Use

Any energy used, emissions generated, other resources affected directly by the product during its actual use are counted during this phase. This includes waste that occurs in the context of a product’s use, such as discarded packaging.

“My product is powered by a person picking it up and drinking from it!” laughed Priscilla. “No product impacts there.”

“Mine isn’t,” Tom sighed. “I guess I’ll take a hit for it using energy from the battery. But aren’t most interactive toys like this one battery-powered?”

End of Life

Once a product is no longer used, it has reached its end of life. This usually means that the product is no longer usable, although there are many examples of end of life coming before end of usability (e.g., paper cups). This phase is usually broken down into three resulting streams: the fraction of a product being sent to landfill, to incineration, and to reuse or recycling.

Priscilla knew that recycling was a big issue for her PET plastic cup. “I guess the recycling rate depends on where the product’s being used,” she said. “I’ll bet it’s higher in Europe than in the US.”

“I’m not so sure about that,” Tom said. “We recycle a lot of our steels and aluminums in the US, if not as much of our plastics. We also landfill more of the rest of the materials, rather than incinerate them, which they favor a bit more in Europe.”

Transportation

Transportation is not typically given as a lifecycle phase, since transportation legs actually occur between each of the lifecycle phases, but it’s an important consideration to account for in the product’s lifecycle impacts. Transportation can be included among the phases according to where it takes place (e.g., the shipping of raw materials to processing centers could be considered a piece of the processing phase). In some cases, transportation may appear as a separate lifecycle component, especially between Assembly and Product Use for consumer products, since there are typically several stops along the way (e.g., wholesaler, retailer, delivery). No matter how it’s handled, it is important to make sure that transportation doesn’t fall through the cracks.

“Most of my components are made in Asia,” Tom jumped in, “but a couple of them aren’t. The speaker comes from Japan, and the acrylic light fixtures come from a little shop in Europe. After the product is assembled in Asia, it’s sent by ship to my main market in the US.”

“Simple for me,” said Priscilla. “The cups are packaged and sent from our factory in Asia and are also sent to the US. I wish we could make them locally,” she added, “I’m sure that would be better for the environment.”

System Boundary

Doing environmental assessments can sometimes be like chasing fractals. Product lifecycles intersect a great many processes, some more directly linked to the product than others. Since an assessment can’t always cover everything, system boundaries clarify what it will include. It’s often helpful to draw a process diagram, and then trace a boundary around what will be measured.

For example, the following figure shows a possible system boundary chart for an assessment of a polystyrene cup, with a functional unit of one cup.

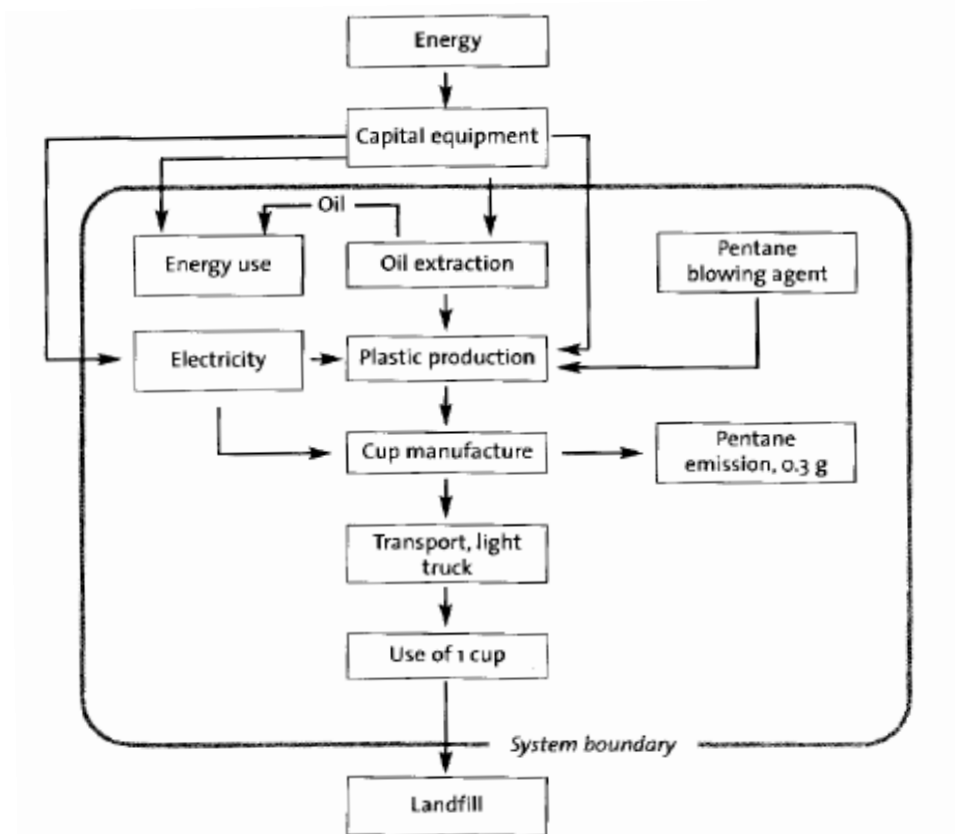

Source: *Design + Environment*, Lewis & Gertsakis, p. 44

Some of the standard product lifecycle system boundary scopes include:

- “Cradle to grave” – Usually denotes all phases from raw materials through disposal.
- “Cradle to cradle” – Like cradle to grave except that it tracks where the product’s elements go after end of use, with special attention to recycling and reuse.
- “Cradle to gate” – Includes part of the product lifecycle, typically either:
 - all upstream phases, not including the assessing company’s own processes; this is used to assess the “environmental burden” of raw materials coming through the door; or
 - all phases through the assessing company’s manufacturing and assembly (the factory gate), bound for the customer, since this is the end of most manufacturer’s ability to directly influence impact.
- “Gate to gate” – A narrowly-scoped lifecycle assessment, focused on only one particular phase or set of phases of the product lifecycle.

Priscilla grabbed a dry-erase marker and sketched out her cup's process diagram:

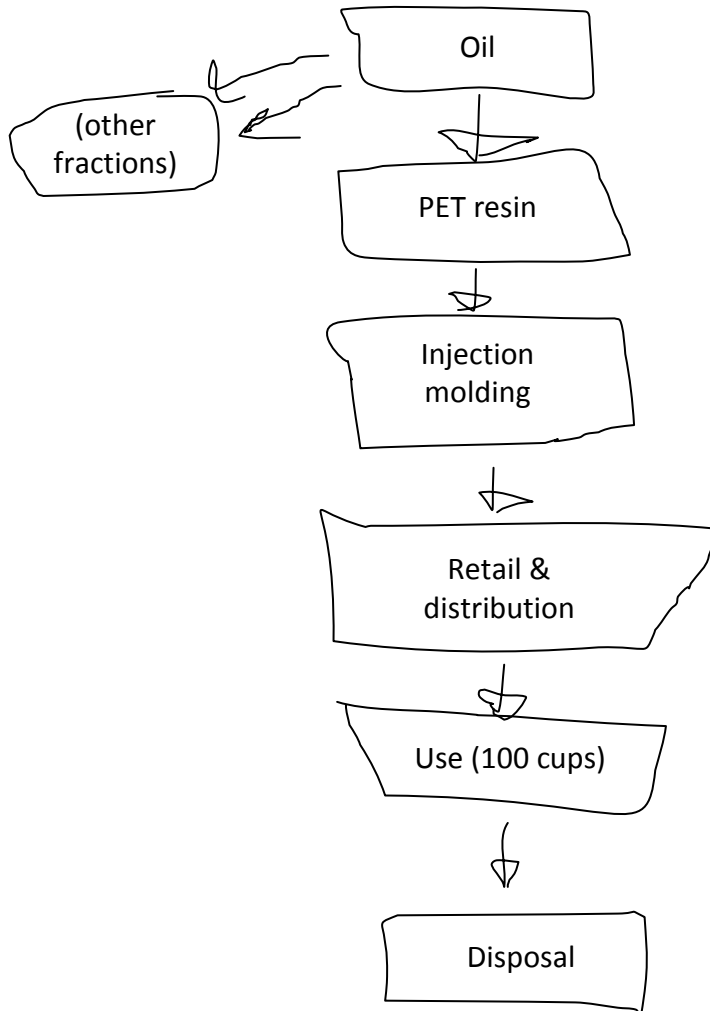

“What about packaging?” asked Tom. “You mentioned that the cups are packed into bags of 100 cups, your functional unit.”

“Oh yeah,” said Priscilla. She added the packaging step to the diagram. “I think the bag is pretty minimal compared to the cups, though,” she said. “So until I get a chance to talk to our packaging group about materials and sizes of the packing materials, I’ll exclude that from my system boundary.” Finally, she grabbed a thick orange marker and drew a box for her system boundary.

Her final sketch was as follows:

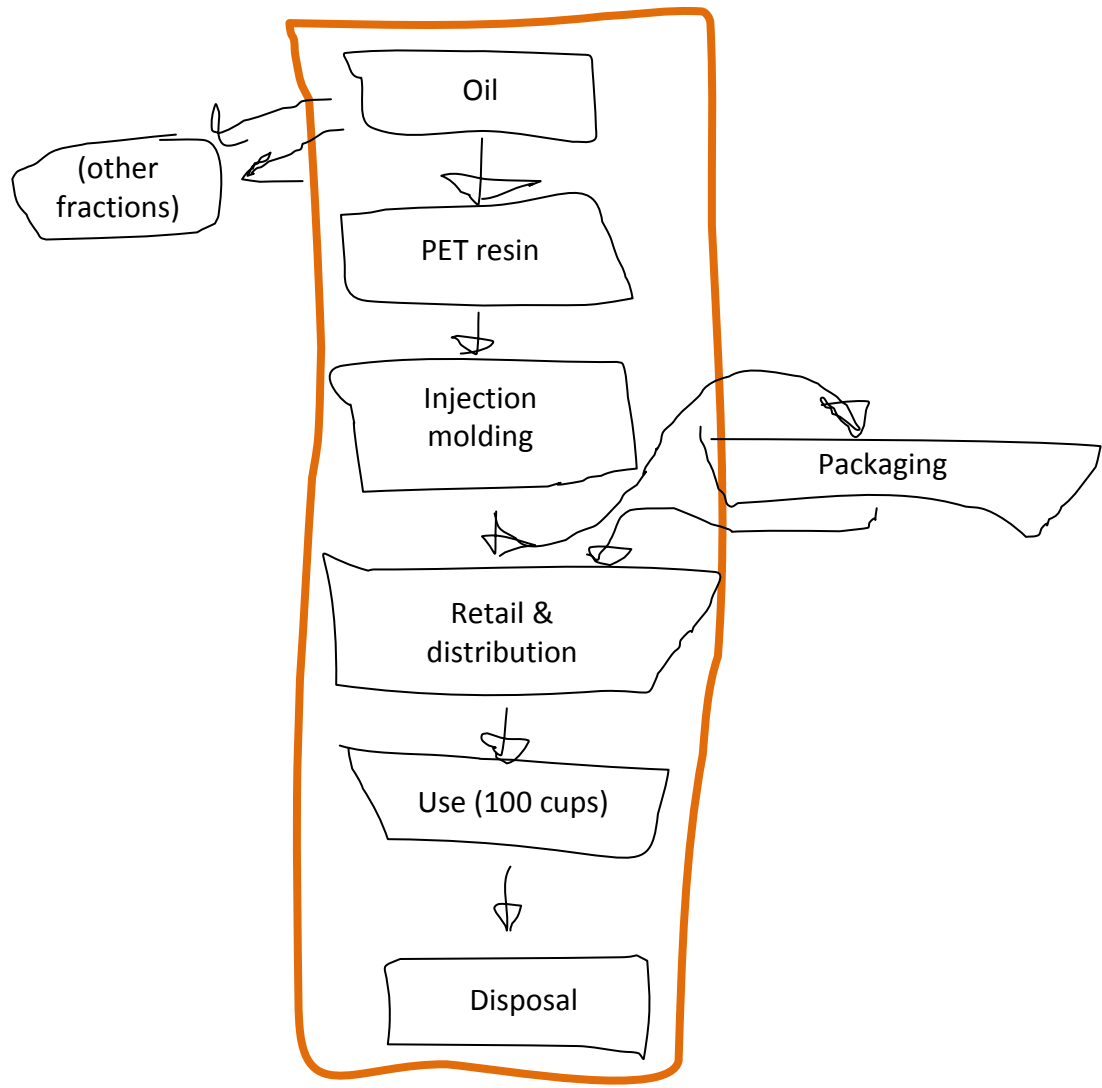

“Mine’s more complex,” said Tom. He stepped to the whiteboard and began to fill his own process steps into Priscilla’s boxes, and add a few of his own:

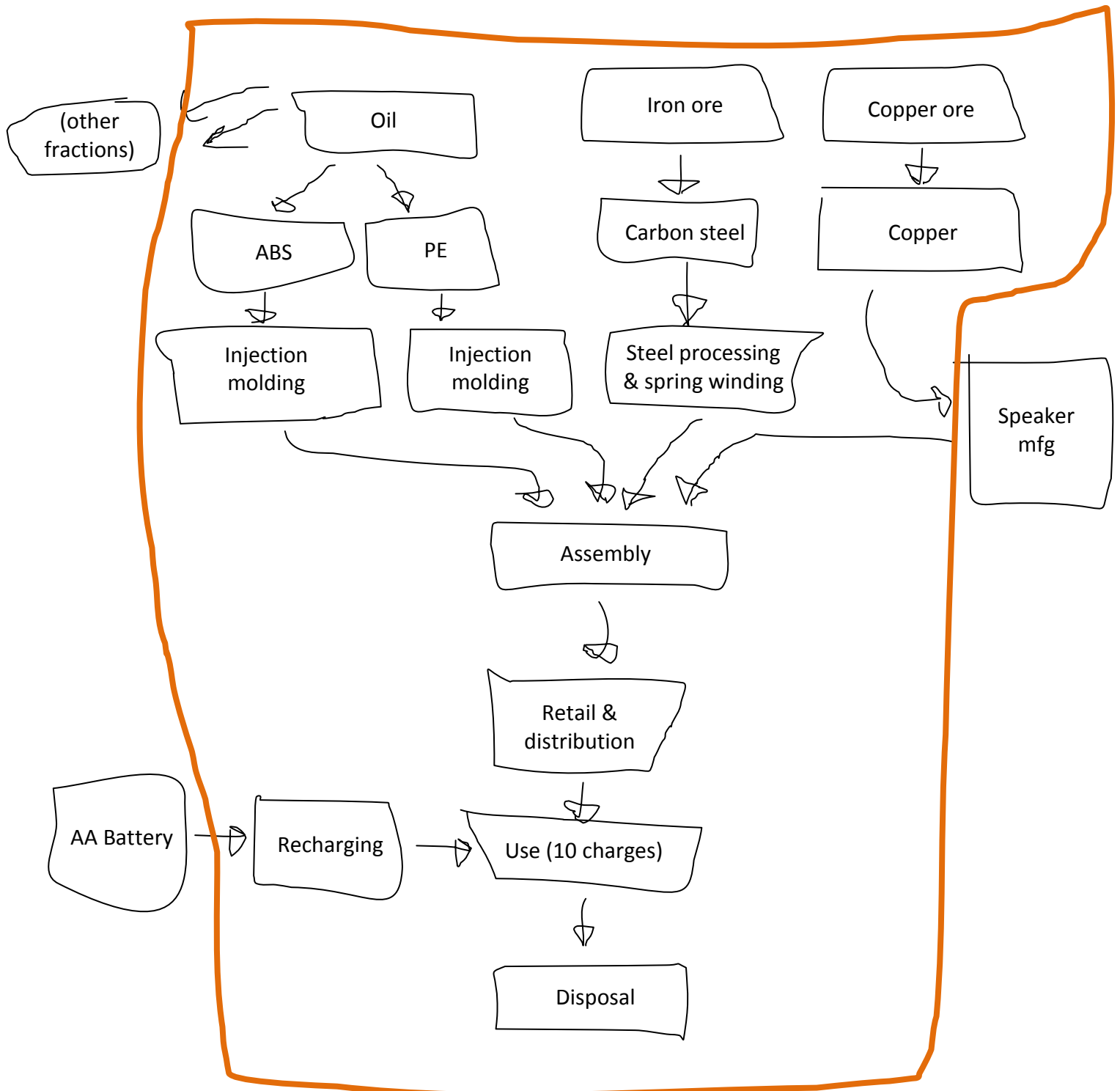

“I’ll have to make some more assumptions,” Tom said, stepping back from the diagram. “I include a rechargeable battery with my toy, and I’ll assume the parent recharges the battery ten times before the kid gets bored with the toy, or outgrows it. But since I want to compare this toy to other interactive ones, I’m going to assume the comparisons are also powered by batteries, so I won’t include that in my system boundary.”

With their lifecycle scopes determined—both were versions of a cradle-to-grave assessment, they realized—and their boundaries drawn, Tom and Priscilla were ready to move to the third and final choice.

Choice 3: Metrics

Once you’ve determined what impacts you want to focus on and how far up and down the product’s lifecycle you want to assess, the final decision is how accurately you need to measure your selected impacts across your chosen lifecycle phases. Once you’ve determined your choice of metrics, you’ll be able to identify the types of impact assessment tools and techniques that will be most useful.

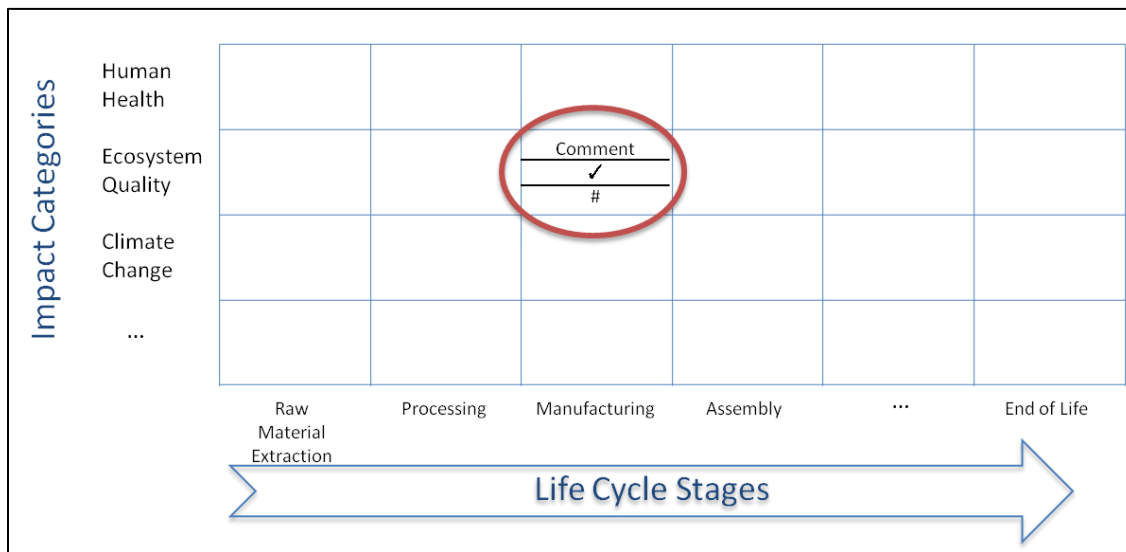

Most metrics fall into one of four categories:

- Comments
- Checkmarks
- Scores
- Measurements

Comments

The most qualitative, and usually most subjective, way impacts are expressed is through text alone. People can generally describe what they believe an impact will look like, its severity, and so forth at a high level based on their understanding of the product. Comparisons read more like product reviews than detailed technical analyses. This form might be appropriate for a first-pass assessment or as a basis for narrowing down alternatives to be compared. It is not a useful format if continuity and standardization is important because it's so subjective.

Checkmarks

In some cases, evaluations are based on checklists. The assessment will have certain criteria for each of the categories, which are either met, or not. Is mercury present? Is it certified organic? Is it FSC (Forestry Stewardship Council) certified? Does at least 25% of the energy used come from renewable resources? Checklists like this have the advantage of resulting in evaluations that are easy to compare across a wide range of products. They can be used relatively (i.e., seeing which of the products has more checkmarks) or absolutely (i.e., all of the parts we use must meet a certain threshold). While the checkmarks don't reflect many details or degrees of difference (i.e., the product that uses 100% renewable energy gets the same checkmark as the one that uses 25% if that's the threshold), they may provide enough information to support relevant decisions.

Scores

Whether in the form of grades, number scales, smiley face icons, or stars, scoring systems have the advantage of the at-a-glance nature of checklists, while also reflecting a more nuanced evaluation of a product's impact. One of the challenges that comes with nuance however is that someone needs to decide whether something gets an A or a B, 3 stars or 4. In many cases, scoring systems lay out guidelines for what qualifies as an A versus a B so that there is some consistency across evaluators and products. Even so, scores can be subjective and, in some cases, political. Still, a balanced and transparent evaluation process can produce a helpful assessment of the scale of a product's environmental impacts. Such scoring systems are especially useful when a quick assessment is needed to initiate the first discussion across a multistakeholder group.

"These are probably beneficial for initial assessment," said Tim, "but that's not what I'm after. I need to get a sense of my actual carbon footprint."

"I agree," said Priscilla. "I've actually used a couple scorecards, where I learned about issues like manufacturing and eventually recycling PET. Now I'd like to put some numbers to this process... you know, some real measurements."

Measurements

The most precise and objective metrics come in the form of specific numbers representing impact levels. These usually take two forms, one impact-specific and the other a standardized conversion into a single proxy number.

Impact-Specific

The impact-specific metric is usually expressed in equivalencies of a certain key component of that impact, such as kilograms of CO₂ for global warming. In this case, no matter what the source of the impact on global warming, it would be converted into the equivalent kilograms of CO₂ (often written as “kg CO₂e,” “kgeq CO₂,” “kg-eq CO₂,” etc.) using standardized equations.¹³

Other common equivalency units for several environmental indicators are listed in the table below.¹⁴

Impact Category	Reference Substance
Human toxicity (carcinogens + non-carcinogens)	kg-eq chloroethylene into air
Respiratory (inorganics)	kg-eq PM _{2.5} (particulate matter < 2.5µm) into air
Ionizing radiations	Bq-eq carbon-14 into air
Ozone layer depletion	kg-eq CFC-11 into air
Photochemical oxidation [= Respiratory (organics) for human health]	kg-eq ethylene into air
Aquatic ecotoxicity	kg-eq triethylene glycol into water
Terrestrial ecotoxicity	kg-eq triethylene glycol into water
Terrestrial acidification/nitrification	kg-eq SO ₂ into air
Aquatic acidification	kg-eq SO ₂ into air
Aquatic eutrophication	kg-eq PO ₄ ³⁻ into water
Land occupation	m ² -eq organic arable land·year
Global warming	kg-eq CO ₂ into air
Non-renewable energy	MJ Total primary non-renewable or kg-eq crude oil (860 kg/m ³)
Mineral extraction	MJ additional energy or kg-eq iron (in ore)

The next challenge is to determine the impact profiles of substances. For instance, what impact does silver have on ozone layer depletion, eutrophication, etc.? There are actually well over a dozen methods for classifying substances.¹⁵ Each maps materials to impacts based on scientific research, with many materials having impacts in multiple categories. The assessment is usually facilitated by software that can take component inputs and calculate allocated impacts based on either actual

¹³ The EPA's Greenhouse Gas Equivalencies Calculator is available online at <http://www.epa.gov/cleanenergy/energy-resources/calculator.html>

¹⁴ Adapted from “IMPACT 2002+” LCIA methodology / Dr. Olivia Jolliet, Univ. of Michigan <http://www.sph.umich.edu/riskcenter/jolliet/impact2002+.htm>

¹⁵ For a good overview of many of the major methods, see Appendix B: LCA and LCI Software Tools in “Life Cycle Assessment: Principles and Practice,” Scientific Applications International Corporation, EPA/600/R-06/060 (May 2006), pp. 74-77.

data gathered or standardized data tables. While there are pros and cons to each assessment tool, some have been adopted more broadly than others. A 2006 survey of 65 lifecycle assessment (LCA) practitioners¹⁶ reported that:

58%* used GaBi (PE International)

31%* used SimaPro (PRé Consultants)

11%* used TEAM (Ecobilan)

Other tools cited:

- BEES (NIST)
- Umberto (ifu Hamburg)
- ECO-IT (PRé Consultants)
- Excel-based spreadsheets
- Math package (e.g. MATLAB, Mathematica)

**percentages include overlap due to usage of multiple tools*

Single Proxy

Because it is difficult to compare the impact of 1 kg-eq CO₂ and 1 kg-eq chloroethylene, for instance, it can be useful to convert all impacts into a single proxy metric. All of the impact-specific equivalencies can be translated into a universal impact factor, often expressed in terms of “millipoints,” sometimes after being normalized based on a national or global reference model. Such single-number impact factors are therefore a weighted measurement showing relative impacts across multiple categories. While there are some standard sets of factors, each represents a specific perspective on what to use as a reference model and how to calculate the conversions. Several of the most widely-used data sets are Eco-Indicator 99 (EI99), EcoInvent, U.S. Life-Cycle Inventory, and CML.

¹⁶ Cooper, J.S.; Fava, J. (2006), "Life Cycle Assessment Practitioner Survey: Summary of Results", *Journal of Industrial Ecology*

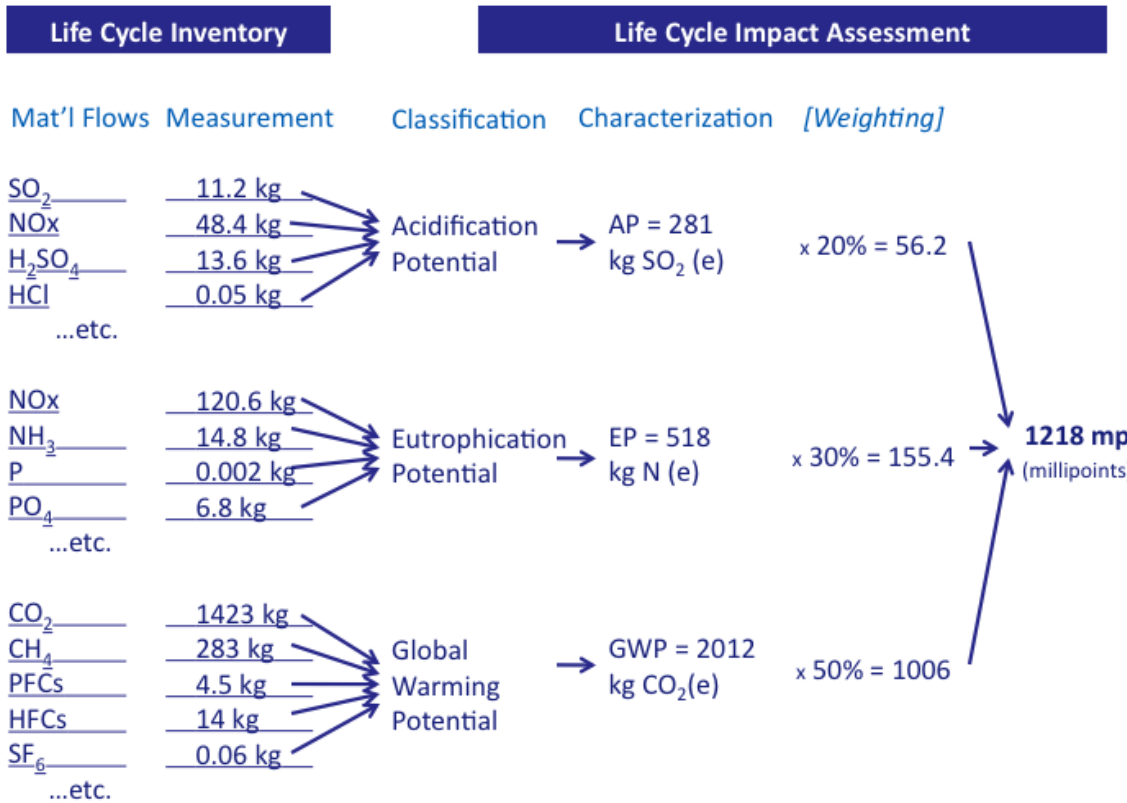

Weighting

Whenever multiple factors are combined and represented by a single number, some sort of weighting takes place. Sometimes all of the inputs are considered of equal value, but in many cases some inputs are given more influence over the final result than others, reflecting a certain prioritization of the importance of each type of impact. Weighting is more of a political (social, cultural) than a scientific process -- giving, say, more weight to the global warming indicator than to acidification is a values-based decision. Stakeholders may differ significantly on their views about the importance of impacts, as shown in the chart below.¹⁷

¹⁷ T.G. Gloria, B.C. Lippiatt, and J. Cooper, "Life Cycle Impact Assessment Weights to Support Environmentally Preferable Purchasing in the United States," *Environmental Science and Technology*, November/December 2007.

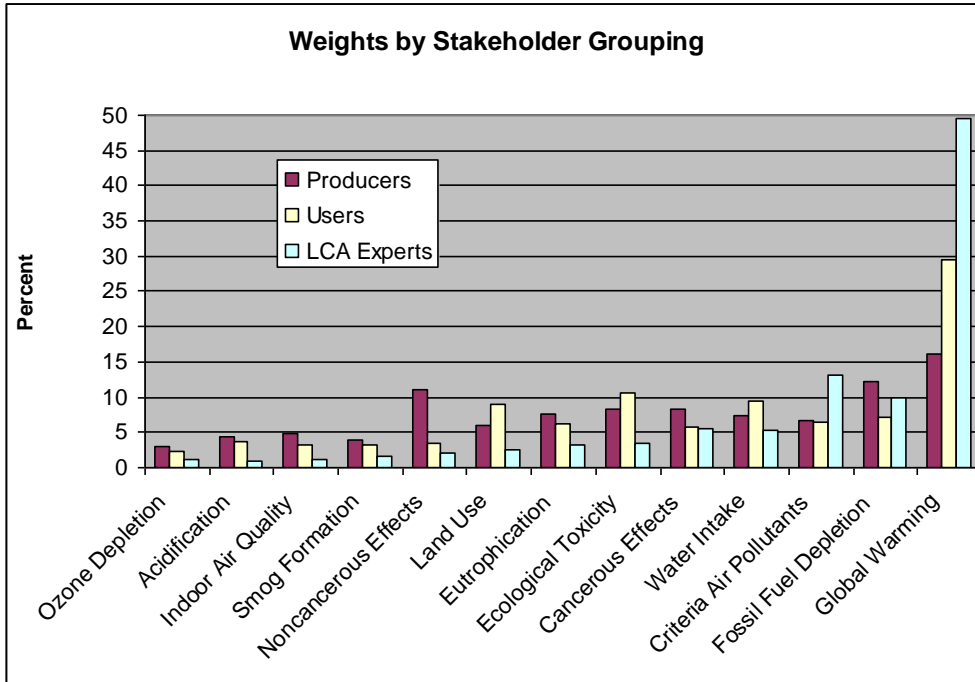

Many practitioners choose to leave the impact scores broken out into categories, with no weighting at all. Although this approach creates a more complicated report, it enables impact comparisons between products on a more granular level.

Weighted “single score” assessments have the advantage of generating one, easy-to-communicate impact number. However, even within the community that supports this approach there are two schools of thought. Some believe that there should be a standard weighting, while others feel that companies should be free to weight impacts as they see fit. One of the advantages of a standard weighting, as is used in the Okala approach among others, is that products can be compared to each other more easily since the single impact scores are only meaningful if compared among products with the same weighting. A second benefit is that companies can’t “game” the assessment to make their products look better than they are by emphasizing the areas in which the product does well and decreasing the effect of categories in which the product has problems.

The advantage of variable weighting approaches is that they can be customized to fit an organizations goals and values. For instance, if an organization is making global warming a priority, it may want to weight that category much more heavily as it’s assessing the impacts of its products. As long as the weighting remains constant within its own assessments, the disproportionate weight it gives to this category is fine. In some cases, there may be external reasons for giving some impacts priority. For instance, there are some sustainability accounting and reporting standards that focus almost exclusively on greenhouse gas emissions, making it useful for organizations using them to put most, if not all, of the weight on that subset of impact factors.¹⁸

¹⁸ Carbon footprint standards such as PAS 2050 and the GHG Protocol fit this description.

“Well, I’ve chosen five indicators, one from each of the domains of impact. I don’t think I want to weight these results together, because I want to choose which ones I’m optimizing for in each design,” said Priscilla.

“And I’m just measuring a single indicator, carbon, so I won’t use any weighted single-proxy results either.

“So now that we know our three choices, what tools can we use?”

Chapter 4: Putting It All Together

While each of the three environmental assessment choices can be made independently to generate an impact assessment, there are several commonly used approaches. These techniques range from relatively quick, cheap, and low accuracy to much more expensive and time-consuming, but with more rigorous and robust results.

Most sustainability assessments, until relatively recently, were qualitative. Data-driven environmental impact measurements have traditionally been too slow or expensive to acquire. Even today, many organizations find that qualitative assessments are good enough for their purposes. Methods vary from “back of the envelope” to more rigorous, as represented by the following techniques.

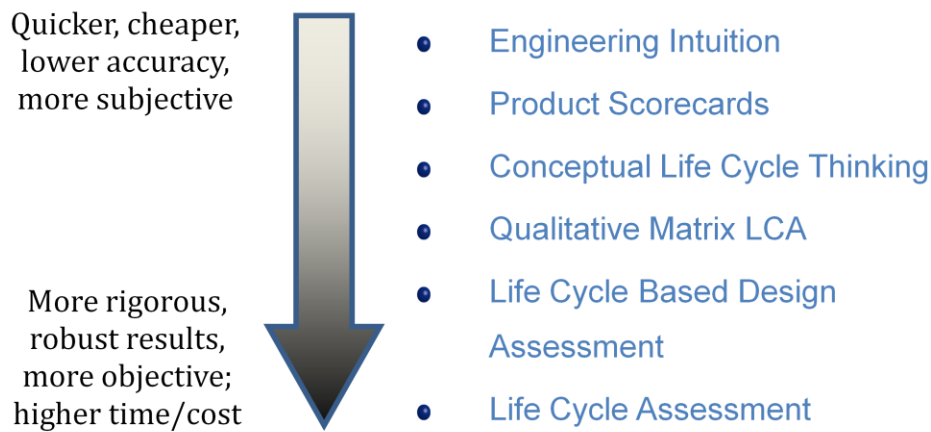

Intuition

Most people have a broad-brush sense for the relative impacts of major design choices. For instance, intuition alone will tell you that a lighter version of a product would save on transportation costs or that a more energy-efficient product would have less of an environmental impact. Unfortunately, there are plenty of counter-intuitive trade-offs and costs unknown to the average designer.

Besides often being uninformed, many people are actually misinformed about the impacts of certain materials. Sometimes materials are attacked in the press and public opinion, painted as evil, toxic stuff. PVC has a terrible reputation, even though analysis will show that in certain applications it is the more environmentally responsible choice. In some cases, it is just because they are the most visible that certain components get the brunt of the negative attention. Transportation and packaging fall into this category, even when they might be far from the biggest problem in a given product’s lifecycle.

On the flip side, there are some very significant marketing dollars at work convincing people how “green” some materials are. The cotton industry touts their product as a natural material, “The fabric of our lives.” While it is true that cotton is a product of nature, its environmental impact is pretty substantial, thanks to the amount of water and insecticides used in conventional cotton farming. In fact, cotton uses approximately 25% of the world's insecticides and more than 10% of the pesticides (including herbicides, insecticides, and defoliants.). Plus, there is the ongoing issue of the increased use of genetically modified cotton. Cotton’s environmental footprint has gotten much better over the years, but the “natural” option might not turn out to be the best sustainable option, despite the hype.

Intuition is fine if that’s all you’ve got, but there are plenty of ways to do better. For example, we’ll test a few of Tom and Priscilla’s intuited assumptions along the way—like her assumption that manufacturing her cups locally would be better.

Mapping **Intuition** to the Three Choices

1. Impacts – Any
2. Scope – System boundary is created by areas engineer is directly familiar with; Any life cycle stages, although usually focused on the most visible ones, such as Use
3. Metrics – Usually in the form of comments, although could be checkmarks, or scores

Product scorecards

Some companies have created scorecards to enable them to evaluate a variety of products with at least some internal consistency. Scorecards of this type are not particularly life cycle-based, but instead focus on the attributes of a product. For example, Norm Thompson Outfitters, with the help of Michael S. Brown & Associates, created a set of 12 scorecards as part of its Sustainability Toolkit, which it uses internally and gives to its suppliers and merchants. The scoring system is a simple 3 (most environmentally responsible) to -3 (least environmentally responsible), with each product element getting a single rating. Each score has examples and criteria listed to help people with their evaluation. For example, in the food category, a 3 indicates a sustainably harvested, organic product, free of toxics in raw material processing. A food is given a score of 0 if it’s on the seafood “watch” list for instance, resulting in moderate ecosystem impacts. Foods scoring -3 would have significant negative ecosystem and human impacts. Fish on the “avoid” list would qualify, for instance. For metal products, recycled gold, silver, and copper would earn a 3, while nickel, lead, and mercury would get a -3. These scores are primarily used to guide sourcing and purchasing decisions.

In another example, the design firm Ximedica (formerly Item Group) created what they call their GreenCard, for internal use. While not a rigorous, in-depth analysis, it is a valuable tool for designers to use in considering product sustainability as they do their work. As its co-founder and Chief Innovation Officer Aidan Petrie put it:

“An awful lot of people are passing very bold statements about the greening of industry, and many of these ideas are big, long-term, transformational, expensive, and complicated. We live in a world of here and now. We have to launch a product next week. We can't wait for plastics that are made out of cornhusks. We have to make plastic parts next year. We have an obligation to that.

“So our GreenCard is a tool that we've developed and refined here that informs and influences the design of that plastic product in the very earliest stages. We go through this checklist... You're making choices all along the way and at the end, you will have a greener product. It may not be that iconic green product, but it would be better than it would have otherwise been, because it had been informed by the GreenCard. ”¹⁹

GreenCard™
Item Group Social and Environmental Scorecard

www.itemmpd.com

Comparison Notes and Recommendations
Refer to Evaluation Guide on following page

Project: _____
Project Manager: _____ Date: _____
Product Description: _____ Revision: _____

CRITERIA **EVALUATIONS**

Instructions: Find a benchmark product, and using 0 as the starting point, score each concept with one or more plus (+) or minus (-) symbols to rate the alternative solution.

	Baseline	Concept#1	Concept#2	Concept#3
Product Composition				
Material Processing	0			
Materials	0			
Recyclable/Biodegradable	0			
Engineering/Specifications				
Assembly	0			
Disassembly	0			
Parts quantity/size	0			
Materials quantity	0			
Product Use				
Life cycle	0			
Energy consumption	0			
Energy source	0			
Packaging				
Materials used	0			
Type	0			
Disassembly	0			
Transportation				
Distance	0			
Pack out	0			
Manufacturing/Regulatory				
SA 8000	0			
ISO 14000	0			
Lean (Six Sigma)	0			
RoHS	0			
Restriction of use of Hazardous Substances	0			
WEEE	0			
Waste Electrical and Electronic Equipment	0			
GMP	0			

Score (+) for Yes and (-) for No

¹⁹ <http://www.providenceri.com/CityNews/newsletter2.php?id=191#feature>

Mapping **Product Scorecards** to the Three Choices

1. Impacts – Any
2. Scope – Focuses system boundary on product itself; usually includes life cycle stages between Part Manufacturing and Product Use, although can include others
3. Metrics – Generally checkmarks or scores

Conceptual Life Cycle Thinking

These approaches consider the life cycle of a product, but tend to have quite qualitative impact evaluations. One of the most popular tools of this type is the Lifecycle Design Strategies (or LiDS) Wheel, also known as the Ecodesign Strategies wheel. It was developed as a part of the United Nations Environment Programme by Hans Brezet and Carolien van Hemel Brezet as a way to evaluate how well a product design reflects the application of eight ecodesign strategies, especially relative to alternative designs. These strategies are usually represented as an eight-axis radar chart, with each design option plotted as overlays, as in the figure below.²⁰

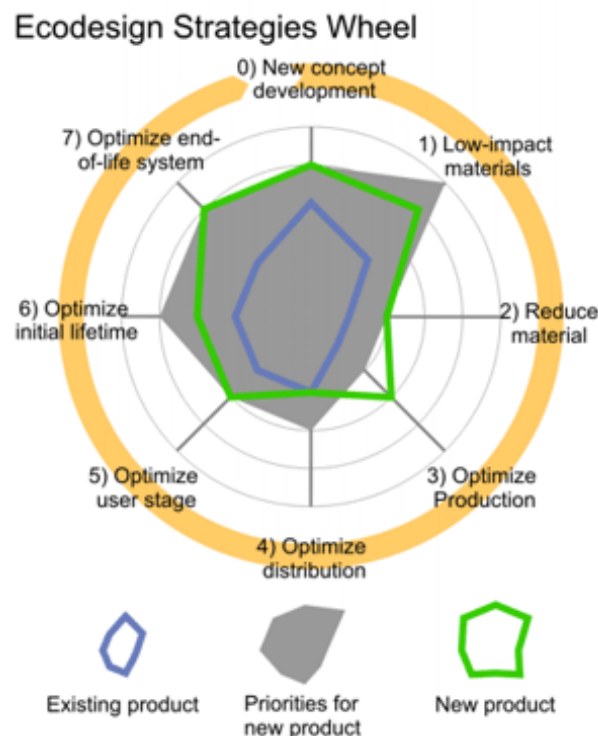

Note that there are no scales defined, plus this reflects the use of strategies, which does not necessarily translate into specific environmental impacts. As stated in the University of Michigan's EcoDesign and Manufacturing materials, "Because the LiDS Wheel Analyses are inherently qualitative, and based on an arbitrarily defined system of evaluation, it is not a method that can be

²⁰ <http://www.matbase.com/guidelines.html>

used to determine the actual environmental impact of a product. It is, however, an excellent method for evaluating environmental tradeoffs between two similar or evolutionary designs.”²¹

Mapping Conceptual Life Cycle Thinking to the Three Choices

1. Impacts – Any, although not always broken out into specifics
2. Scope – All lifecycle stages (or the ones we’ve chosen to focus on)
3. Metrics – Generally scores

Qualitative Matrix Life Cycle Assessment

Life Cycle Assessment (LCA) describes the process of evaluating the environmental impacts of a product at each stage of its life and overall. While full LCAs can be intensively data-driven, as will be described in the following sections, sometimes a qualitative assessment is all that is required. Such evaluations can be used as stand-alone decision tools, but often they serve to identify the design options worth more detailed analysis. Evaluations can be text-based or scored, but there are no standard axes or rating systems so organizations can adopt whatever metrics work for their purposes. This figure shows an example of one such matrix used by 3M.²²

STAGES IMPACTS	← Before Customer					Customer →	
	Material Aquisition	R&D Operations	Manufacturing Operations		Wrhs, Distrib, Transport	Product Use, Reuse, Maintenance	Recycle, Final Disposal
	A	B	C	D	E	F	G
ENVIRONMENT							
Air	1						
Water	2						
Solid Waste	3						
ENERGY							
RESOURCE USE	4						
5							
HEALTH							
Chemical	6						
Physical	7						
Biological	8						
SAFETY							
Chemical	9						
Electrical	10						
Mechanical	11						
<p>Please enter the following marks as appropriate:</p> <p>√ - Impacts understood and Risks adequately addressed ? - Impacts/Risks not completely understood</p> <p>* - Impacts understood but Risks require further attention + - EHS Advantage</p>							

²¹ <http://www.engin.umich.edu/labs/EAST/me589/ecodatabasefinal/design/lids/concepts.html>

²² Edmund E. Price, Donald R. Coy, "Life cycle management at 3M: A practical approach", *Environmental Management and Health*, Vol. 12 Iss: 3 (2001), pp. 254 – 259.



Evaluation approaches become even more effective when adopted by more than one company, or even by a whole industry. One example of this is the apparel industry’s Eco Index, created through the collaborative efforts of over 100 producers and retailers and coordinated by the Outdoor Industry Association.²³ The resulting software application guides its users through a set of questions for each of six life cycle phases, focused on seven key areas of impact.²⁴

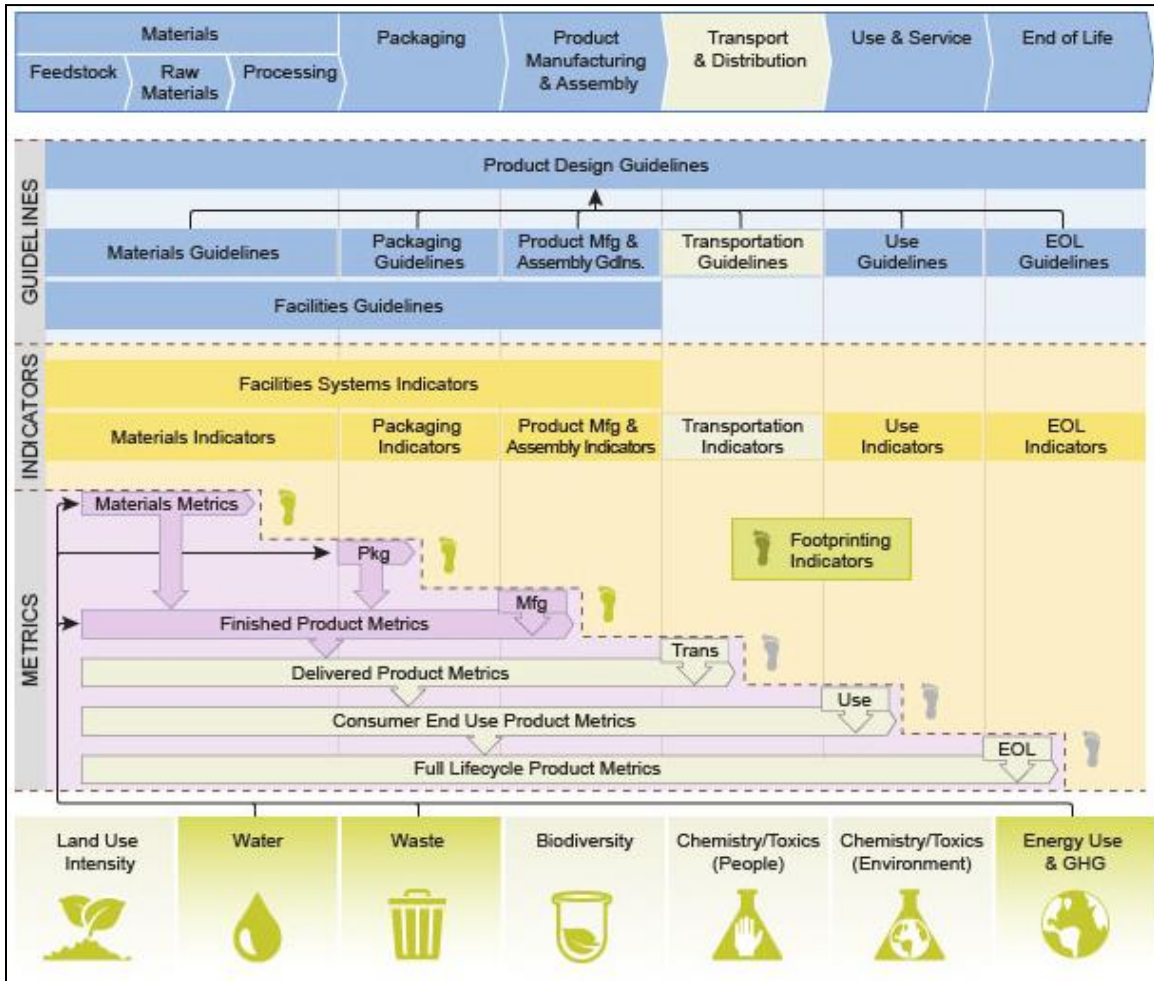

The scoring system is based on points awarded based on meeting various criteria. For example, in the Packaging area, Post Consumer Recycled (PCR) Content scores range from 0 for “unknown or 0-29% post consumer recycled content” to a maximum of 8 for 100% PCR content. Such scoring systems try to reflect the scale of impact somewhat quantitatively, although the direct impact of changes is hard to see. The scorecard’s guidelines state that use of PCR leads to resource conservation such as less energy used, less waste produced, and less virgin raw material extracted, but does not say how much. Therefore, it is not easy to tell whether it makes a big or small difference changing from, say, 29% PCR to 30% PCR to get an extra point on the scorecard, something product designers may want to know. Plus, a one point change due to PCR use may

²³ Eco Index website: <http://www.ecoindexbeta.org/>

²⁴ Image from: <http://www.ecoindexbeta.org/content/index-tools>

have very different environmental impacts than a one point change in raw material input use efficiency. Results are in the form of points, not impacts.

Qualitative impact assessments tend to be quicker, less expensive, and easier for non-specialists to participate in and understand than quantitative ones. Their lack of precision can be acceptable for many high-level decisions, or for indicating when it is worth investing the time and effort required to generate a more detailed understanding of the environmental impacts that many quantitative methods can provide.

Mapping Qualitative Matrix LCA to the Three Choices

1. Impacts – Any
2. Scope – All lifecycle stages (or the ones we've chosen to focus on)
3. Metrics – Generally scores

Life Cycle-Based Design Assessment

There is an impact evaluation approach that reflects life cycle thinking and is more quantitatively rigorous than the techniques described above, but is still useful for design-stage evaluation. Life cycle-based design assessments reflect many of the attributes of full life cycle assessments, but are based on product models and not on full studies of a product's actual environmental impacts. Because they usually draw upon one or more existing impact data sets, they have the advantage of being useful in making data-driven design decisions while still at the drawing board. Most are software applications, allowing fast data search and impact calculations.

Industry-specific

Some approaches of this type are focused on particular industries or applications. The Comparative Packaging Assessment (COMPASS)²⁵ is an online tool developed by the Sustainable Packaging Coalition (SPC), a project of the nonprofit institute GreenBlue. Drawing upon life cycle impact data from the U.S. Life-Cycle Inventory (LCI) Database and Ecoinvent (a Swiss LCI database), it allows engineers and packaging designers to model the impacts of their choices while still in the design phase. It calculates profiles of product life cycle impacts in three main categories.

Consumption Metrics

- Fossil Fuel
- Water
- Biotic Resource
- Mineral

Emission Metrics

- Greenhouse Gas
- Clean Production: Human Impacts

²⁵ See <https://www.design-compass.org/>

- Clean Production: Aquatic Toxicity
- Eutrophication

Packaging Attributes

- Content (Recycled or Virgin)
- Sourcing
- Solid Waste
- Material Health

Industry-agnostic

Other tools, such as SolidWorks Sustainability, don't focus on one particular design domain, but allow modeling of a wide range of products. SolidWorks has chosen its approach specifically to meet the needs of designers and engineers who want to incorporate pre-production modeling of environmental impacts into their product development process.

Like other tools of this type, SolidWorks Sustainability uses secondary LCA data to develop a quick, robust assessment, which could be called a "screening LCA" or an LCA-based design assessment. But because it doesn't use the company's own primary data, SolidWorks Sustainability shouldn't replace comprehensive LCA software, such as PE International's [GaBi software](#).

SolidWorks Sustainability should be used as an environmental impact dashboard, giving immediate feedback on the impact of design decisions. Although it may be considered LCA "light," it is powered by PE International's LCA database (confusingly also called GaBi), and uses a general process model made using the GaBi LCA software. This powerful engine provides designers with the tools appropriate for creating comparative models and making educated trade-off decisions. Its integration with SolidWorks' 3D modeling suite enables real-time impact analysis during the design process.

In SolidWorks Sustainability, impacts are represented in several categories. It assumes that designers benefit from more granularity than a single number score can give, but that environmental impacts can easily be understood and estimated by using a small set of key environmental indicators. It currently shows four types of environmental impacts:

- Natural resource depletion: ***Non-Renewable Lifecycle Energy Demand***
- Impact to the air: ***Air Acidification***
- Impact to water/earth: ***Water Eutrophication***
- Impact to the climate: ***Carbon Footprint***

SolidWorks Sustainability has been developed to enable sustainable design in the context of product design, helping developers make informed choices about environmental impacts early enough in their life cycles to lock in benefits from the start. With tools of this type, environmental impact becomes a design decision and not a post mortem examination.

Mapping Life Cycle-Based Design Assessment to the Three Choices

1. Impacts – Any
2. Scope – All lifecycle stages (or the ones we've chosen to focus on)
3. Metrics – Measurements based on data tables

Life Cycle Assessment

Several of the other methods described so far have addressed each of the components of a product's life cycle. There is however a specific process called Life Cycle Assessment (LCA) with a standardized set of steps and output in the form of environmental impact measures. In fact, life cycle assessment is part of the ISO 14000 (environmental management) standards, and is specifically addressed by ISO 14040:2006 and 14044:2006.

LCA is defined as “an objective process to evaluate the environmental burdens associated with a product, process, or activity by identifying energy and materials used and wastes released to the environment, and to evaluate and implement opportunities to affect environmental improvements.”²⁶ Performing a full LCA requires significant expertise and effort. There are many resources available that go into much more detail about the process than this guide covers.²⁷ However, it is useful to at least be familiar with the four major steps of the standardized LCA process:

1. Goal and Scope Definition – *What are we trying to learn?*
2. Life Cycle Inventory (LCI) – *What's embedded in the product?*
3. Life Cycle Impact Assessment (LCIA) – *What effects does it have?*
4. Data Interpretation – *What does it all mean?*

²⁶ Society of Environmental Toxicology and Chemistry (SETAC), 1990

²⁷ See for instance “Life Cycle Assessment: Principles and Practice,” Scientific Applications International Corporation, EPA/600/R-06/060 (May 2006)

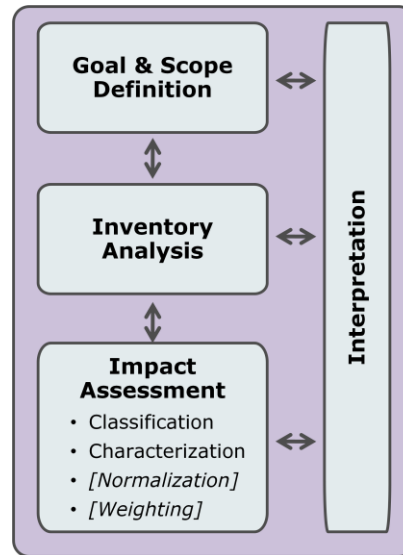

Goal & Scope Definition

As with other assessments, the first step involves clarifying the purpose and extent of the LCA. This entails formally determining the functional unit, impacts of interest, and system boundary—elements from our “First Choice”.

While LCA “light” approaches have been described above, a “full” LCA includes actual primary environmental impact data gathered once the product’s full lifecycle has been determined. Such detailed LCAs take, on average, three months²⁸ and cost \$10,000-\$60,000²⁹, and are only possible to complete once the product is in use and has gone through all phases of its life cycle. This increased accuracy is worth it for benchmarking or external reporting (such as green marketing) purposes.

Inventory Analysis

The next phase entails creating a list of all of the components of the products life cycle that fall within the defined system boundary. It has three major steps:

1. Construct a process flowchart that shows the following:
 - Raw materials
 - Mfg processes
 - Transports

²⁸ “A full (internal) LCA study takes 8-16 weeks to complete.” <http://www.industrial-ecology.com/services/lifecycleassessment.html>

²⁹ B Resource Guide: Conducting a Life Cycle Assessment (LCA), Feb. 2008, p. 6. [http://www.bcorporation.net/resources/bcorp/documents/B%20Resources%20-%20Conducting%20a%20Life%20Cycle%20Assessment%20\(LCA\).pdf](http://www.bcorporation.net/resources/bcorp/documents/B%20Resources%20-%20Conducting%20a%20Life%20Cycle%20Assessment%20(LCA).pdf)

- Uses
 - Waste management
2. Collect data for:
 - Material inputs
 - Products and byproducts
 - Solid waste, air and water emissions
 3. Calculate the amounts of each in relation to the functional unit

Essentially, this is the process flow diagram—with detailed mass and energy values attached—that Tom and Priscilla sketched out. The resulting Life Cycle Inventory (LCI) provides a breakdown of all of the energy and materials involved in a product's system at a level of detail that provides a basis for evaluation.

Impact Assessment

Once a detailed LCI is created, environmental impacts can be ascribed to its parts, and if desired to the whole system. There are four steps to the Life Cycle Impact Assessment (LCIA) process, the first two of which are considered mandatory, while the last two are optional.³⁰

1. Classification

Classification involves assigning specific environmental impacts to each component of the LCI. It is here where decisions made during the scope and goal phase about what environmental impact categories are of interest come into play.

2. Characterization

Once the impact categories have been identified, conversion factors – generally known as characterization or equivalency factors – use formulas to convert the LCI results into directly comparable impact indicators as described in the Measurements section above.

3. *Normalization (optional)*

Some practitioners choose to normalize the impact assessment by scaling the data by a reference factor, such as the region's per capita environmental burden. This helps to clarify the relative impact of a substance in a given context. For instance, if global warming contributions are already high in the context in which the product is being assessed, a reference factor would normalize whatever the product's global warming contributions are in order to clarify its relative impacts.

4. *Weighting (optional)*

The pros and cons of weighting were described in the Measurements section above.

Interpretation

Although listed fourth, life cycle interpretation actually occurs throughout the whole LCA. It involves the ongoing process of clarifying, quantifying, checking, and evaluating the information

³⁰ As dictated by the ISO 14044 standard

used by, and resulting from, the life cycle inventory (LCI) and impact assessment (LCIA) phases. The standard that covers the LCA process, ISO 14044, gives two main objectives:

1. Analyze results, reach conclusions, explain limitations, and provide recommendations based on the findings of the preceding phases of the LCA, and to report the results of the life cycle interpretation in a transparent manner.
2. Provide a readily understandable, complete, and consistent presentation of the results of an LCA study, in accordance with the goal and scope of the study.

To achieve these objectives, the ISO standard states that interpretation should cover at least three major elements.

1. Identification of the significant issues based on the LCI and LCIA. Which life cycle phases or components stand out as major contributors to overall impact? What are the anomalies?
2. Evaluation which considers completeness, sensitivity, and consistency checks. Is all the information needed for interpretation present in the LCI and LCIA? How reliable is the information related to any identified significant issues? How much do changes in such factors influence the overall results? Are all of the assumptions, data, characterization factors, etc. that were used in the assessment consistent internally and with the overall goal and scope of the LCA?
3. Conclusions, recommendations, and reporting. As discussed in later sections of this guide, a great deal of an LCA's value depends on how its results are communicated to people involved in making relevant decisions, whether other designers, engineers, management, marketers, or other parts of the supply chain.

Although LCA is the most comprehensive impact assessment, even full, ISO 14044-compliant LCAs are never the definitive answer. They require interpretation, which in turn requires transparency and judgment. The data sources, assumptions, and all other relevant information must be transparent to decision makers so that they can understand the full context of the results of the life cycle inventory assessment. Deciding among design options is not as easy as just comparing LCIA numbers, whether single- or multi-factor, weighted or not. LCIA results can be a source of insights, but do not stand alone in guiding product development choices. Engineers will need to take them in the context of the other attributes they are trying to optimize, including cost, manufacturability, performance, and so on. In addition, there are myriad other factors guiding product development decisions not covered by LCAs, including social impacts and acceptance, pricing, political agendas, and regulations.

Mapping Life Cycle Assessment to the Three Choices

1. Impacts – Any
2. Scope – All lifecycle stages (or the ones we've chosen to focus on)
3. Metrics – Measurements from actual product life cycle, supported by data tables

“Whew, I never knew environmental assessment was such a complex world!” breathed Tom.

“Well, we’ve already decided that we wanted to use measurements for our Third Choice, the one on metrics. If only there were a handy table to show us what Tools were available to us now, given our three choices.”

A Handy Table of Tools for the Three Choices

	Choice 1: Impacts	Choice 2: Scope	Choice 3: Metrics
Intuition	Any	Visible phases	Comments, checkmarks, scores
Product Scorecards	Any	Set boundary, usually product mfg and assembly	Checkmarks, scores
Conceptual Life Cycle Thinking	Any (but usually not specific)	All (or selected) lifecycle phases	Scores
Qualitative Matrix LCA	Any	All (or selected) lifecycle phases	Scores
Life Cycle-Based Design Assessment	Any	All (or selected) lifecycle phases	Measurements (secondary data)
Life Cycle Assessment (LCA)	Any	All (or selected) lifecycle phases	Measurements (primary data)

“It looks like what I need is a Life Cycle-Based Design Assessment,” said Priscilla. “Since I already have my model in SolidWorks, it makes sense for me to use Sustainability.”

“I do too,” said Tom. “So I’ll start out in SolidWorks Sustainability too. But if I want to use my results in marketing, I’ll eventually need to do an LCA to verify the results.”

So what? (Using the results of your assessment tool)

The previous sections have laid out the context of sustainability and described how to know it when you see it. However, all of that information is irrelevant if it doesn't enable action—the point of assessing and reporting environmental impacts is to give you information on how design choices affect the relative sustainability of one product compared with other options. This section and the ones that follow show how to put all of that information into action.

The first step is to determine what the results of the environmental impact assessments mean. No matter which tools or techniques you used, you should have some impact information about your product. As was noted earlier, sustainable design is a relative concept, so you should also have impact information against which to compare it. Common comparisons include:

- **Standards:** These may be certain thresholds or impact profiles that have been accepted as industry, or maybe even just company, standards.
- **Previous Designs:** The goal may be to make each generation of a product more sustainable than the previous one.
- **Competitive Products:** Whether for market positioning or internal purposes, it is sometimes helpful to compare to other companies' solutions.
- **Alternative Designs:** One of the most common is to compare variations on a given design to each other to narrow down development to the best, most sustainable design options.

The comparison set should have been identified early in the process so that relevant impact information about the alternative designs could be gathered as a part of the overall process.

As you conduct the comparisons, it's important to know what differences are meaningful. The significance of any differences identified will depend on the products and the measurement approach used. For even the more data-driven techniques used, not all incremental improvements are worth investigating. As a simple rule of thumb:

- A +/- 10% difference on one or several environmental indicators gives an indication that the changes between the options can be considered “directionally” correct. Chances are, you're moving on the right path.
- For a relatively simple product—like Priscilla's cup—a difference of +/- 30% on the indicator(s) is generally a meaningfully *greener* product.
- For a more complex product, the decrease in impact that you should look to see to identify a greener product are higher, perhaps +/- 40-50%, because the chances of overlooking process steps or incorrectly modeling some assumptions increase with the complexity of the product.

These may seem like large percentages, but they can serve as a helpful reminder not to get caught up in trying to tweak less relevant aspects of a product and instead to focus on the major contributors to its impacts. This is particularly true given the need for the designer to simultaneously balance the environmental impacts of a product with its cost, durability, and other design criteria, along with how it fits in with the overall product strategy.

“Wow, that’s not as accurate as I thought given all of the calculations behind our LCA data,” said Tom reflectively.

“Actually, I think it’s pretty accurate,” responded Priscilla. “Keep in mind that measuring a single product’s impact on a global environmental metric like climate change is like trying to predict the weather in Boston a thousand years from today.”

Once you have a sense for which impact areas are worth looking at, whether because of the significance of their differences from alternatives or other reasons (e.g., a corporate focus on carbon footprint), it is time to look for ways to reduce those impacts as effectively as possible. In many cases, there are certain elements of the design or product life cycle that generate most of the impact. It’s often a classic example of the 80/20 rule, with 20% of the design contributing 80% of the impact. For instance, in decreasing the impact of an electric coffeemaker the temptation might be to remold the plastic housing, since plastic is generally considered a less-than-sustainable material. However, simply shortening the electric cord decreases its overall impact many times what is saved by replacing the handle; and decreasing its energy usage may even dwarf that impact.

“Alright, enough preparation, Tom! I think we know enough now to responsibly dig into our products. Can I go first?”

Chapter 5: A Redesigned Cup – Priscilla’s Challenge

“Let’s start by opening up SustainabilityXpress in the part model,” said Priscilla. “I don’t have full Sustainability, but I should be able to do what I need to do for my part.” Tom looked over Priscilla’s shoulder as she fired up SustainabilityXpress.



Download the models from Chapter 5 (Guide_cup_files.zip) at <http://www.solidworks.com/sustainability/training/learning-resources.htm> and open the model `Guide_cup_original.sldprt` to play along with this example.

“Alright, I see a list of drop-down options to input some basic design parameters so that it can calculate my impacts. First, I’ll make sure the materials are set correctly.”

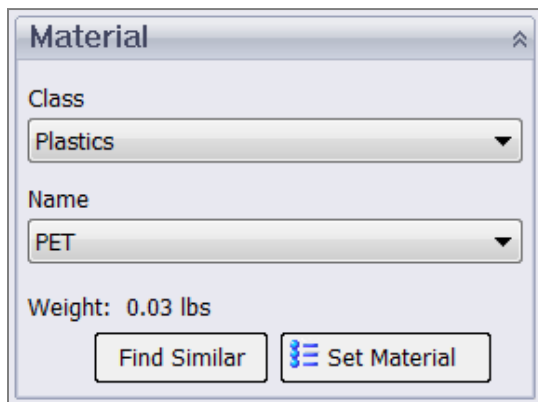

“Yep, there’s the PET. Looks like it’s a pretty light part. And there’s the ‘Find Similar’ tool, I definitely want to check that one out.

“Next it’s asking me about the manufacturing process for the part. Let’s see,” said Priscilla as she glanced at her process flow diagram sketch, “it’s Injection Molded in Asia, and let’s look at the scenario of using it in the North American markets.”

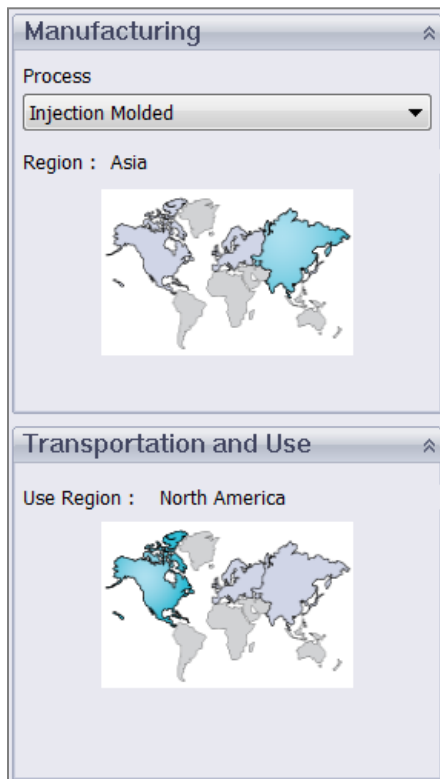

“How does it get from Asia to North America?” asked Tom.

“Well, it goes by boat, but it looks like there’s no option to set the transport mode in my version... but I think there’s some defaults posted on what it uses.” Priscilla checked out the [SustainabilityXpress Default Distances](http://www.solidworks.com/sustainability/training/learning-resources.htm) at <http://www.solidworks.com/sustainability/training/learning-resources.htm> and confirmed that it assumes her stacks of cups are shipped from ports in Asia to North America.

“And wow, that’s all I need. SustainabilityXpress is now giving me some estimates of the environmental impact.

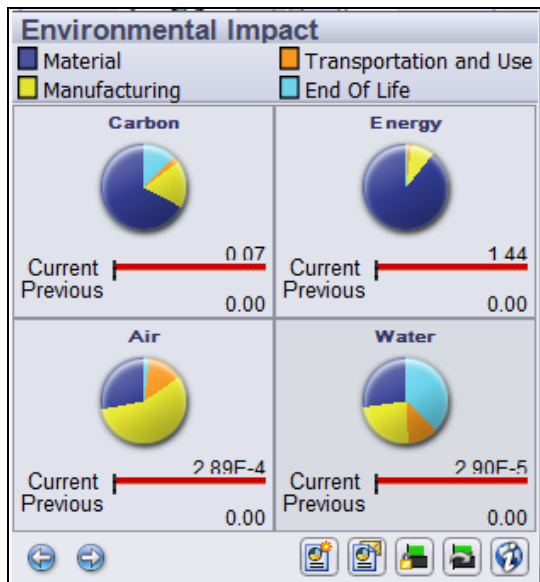

“See, it has four of the five domains that I wanted to measure. It estimates that a single cup is responsible for:

- 0.07 kg-eq CO₂, or 70 grams of carbon-equivalent greenhouse gases;
- 1.44 MJ of non-renewable energy consumed throughout the lifecycle (wow, that’s a lot for a little cup!);
- 2.89×10^{-4} kg-eq SO₂ of Air Acidification; and
- 2.90×10^{-5} kg-eq PO₄ of Water Eutrophication.

“Well, about the only measurement that I have a feel for in the absolute sense is the energy demand. I guess I’ll set this as the baseline so I can play with some different designs and see how they compare.”

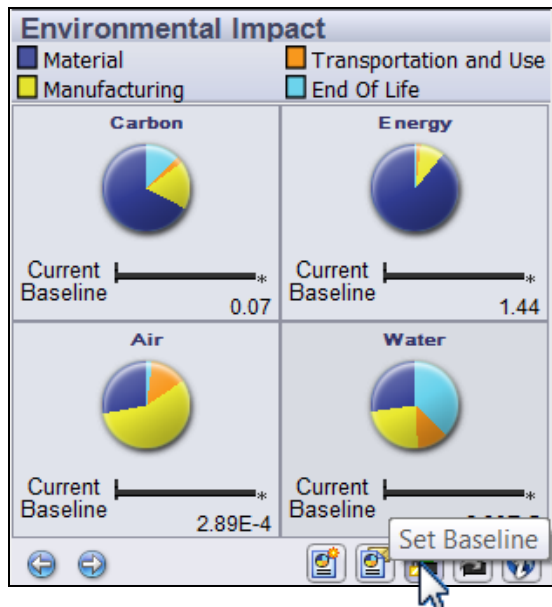

After setting the baseline, Priscilla saved the model and then did a Save As to play with some new redesign parameters in a clean file. (Her saved file with the Sustainability options set is saved as `Guide_cup_baseline.sldprt` in the collection of Chapter 5 files [Guide_cup_files.zip] at <http://www.solidworks.com/sustainability/training/learning-resources.htm>).

“Now for the redesign. I want to start by doing the obvious thing and seeing the effects of manufacturing this locally, in North America where it’s being used.” Priscilla changed the manufacturing location from Asia to North America, and her eyes opened wide at the result:



“What?! It’s actually not clearly better to manufacture locally! It appears to be better for air and water impacts, but since I’m trying to optimize on all four impacts, I have to reconsider since it’s worse on carbon and energy demand. I guess that’s because trucking my cups around within North America has greater impacts per mile than shipping all the way from Asia.”

“Yeah, transported miles aren’t all equal when it comes to environmental impact. How about trying to change the material you’re using instead?” offered Tom. Priscilla nodded and changed the options back to manufacturing in Asia. She then clicked the “Find Similar” tool, and was presented by the following dialog box.

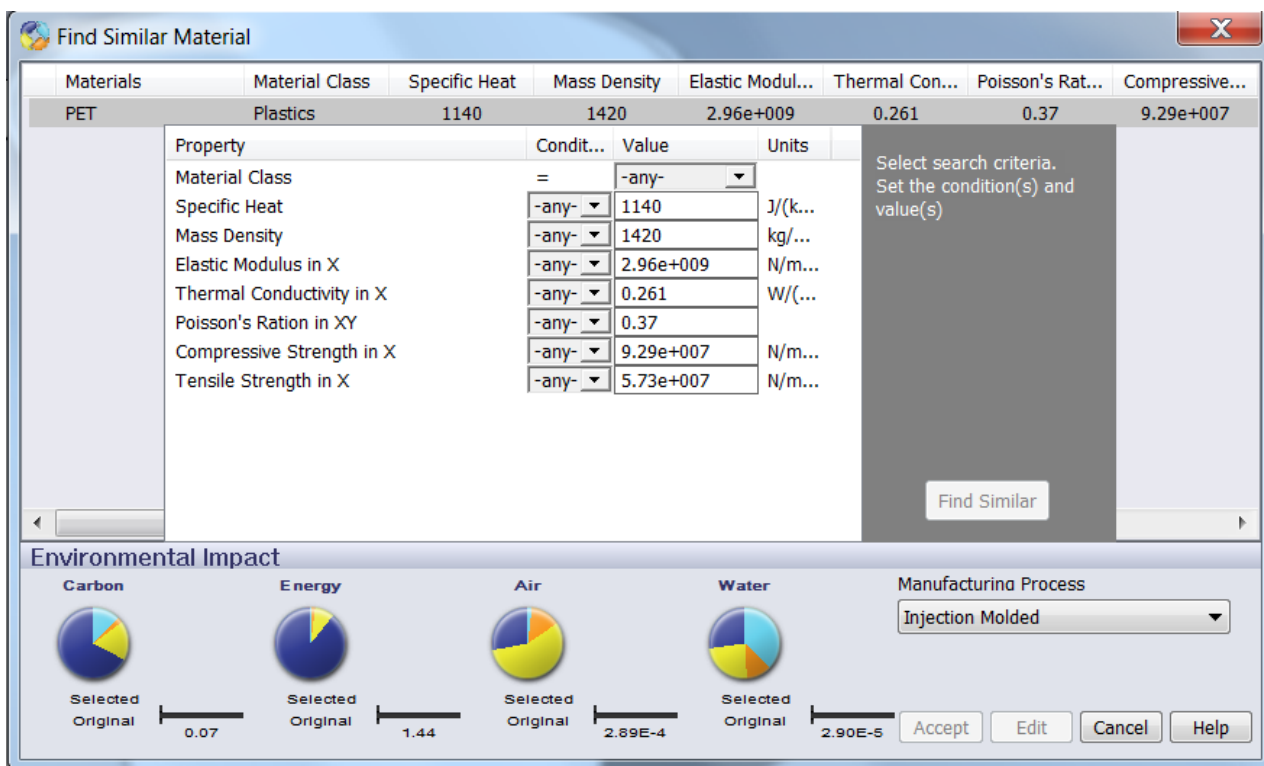

“OK, these are the engineering properties of my PET material, and I can see the baseline impacts of my part down below. It’s asking me to narrow down my engineering requirements so that it can suggest alternate materials.

Let’s see. I don’t want to leave the class of plastics, because that’s what I’m comfortable working with. I want to try a polymer that’s lighter than PET so that I can reduce the weight for transport, but I need a certain minimal strength so that it doesn’t break in packing and shipping.” Priscilla narrowed the options to reflect these requirements:

Materials	Material Class	Specific Heat	Mass Density	Elastic Modul...	Thermal Con...	Poisson's Rat...	Compressive...	Tensile Stren...
PET	Plastics	1140	1420	2.96e+009	0.261	0.37	9.29e+007	5.73e+007

Property	Condit...	Value	Units
Material Class	=	Plastics	
Specific Heat	-any-	1140	J/(k...
Mass Density	<	1420	kg/...
Elastic Modulus in X	-any-	2.96e+009	N/m...
Thermal Conductivity in X	-any-	0.261	W/(...
Poisson's Ration in XY	-any-	0.37	
Compressive Strength in X	-any-	9.29e+007	N/m...
Tensile Strength in X	>	2e+007	N/m...

Select search criteria. Set the condition(s) and value(s)

Find Similar

Environmental Impact

Carbon: Selected Original 0.07

Energy: Selected Original 1.44

Air: Selected Original 2.89E-4

Water: Selected Original 2.90E-5

Manufacturing Process: Injection Molded

Accept Edit Cancel Help

“And now let’s click ‘Find Similar’ and see what it suggests!”

Find Similar Material
X

Materials	Material Class	Specific Heat	Mass Density	Elastic Modul...	Thermal Con...	Poisson's Rat...	Compressive...	Tensile Stren...
<input type="checkbox"/> PET	Plastics	1140	1420	2.96e+009	0.261	0.37	9.29e+007	5.73e+007
<input type="checkbox"/> ABS	Plastics	1386	1020	2e+009	0.2256	0.394		3e+007
<input type="checkbox"/> ABS PC	Plastics	1900	1070	2.41e+009	0.2618	0.3897		4e+007
<input type="checkbox"/> Acrylic (Medium-high impa...	Plastics	1500	1200	3e+009	0.21	0.35		7.3e+007
<input type="checkbox"/> CA	Plastics	1900	1310	2.41e+009	0.2618	0.3897		4e+007
<input type="checkbox"/> Delrin 2700 NC010, Low Vi...	Plastics		1410	2.9e+009		0.3		4.07e+007
<input type="checkbox"/> Epoxy, Unfilled	Plastics		1100	2.415e+009	0.188	0.35	1.04e+008	2.8e+007
<input type="checkbox"/> EPDM	Plastics		900					2.4e+007
<input type="checkbox"/> Nylon 101	Plastics	1500	1150	1e+009	0.53	0.3		7.928971e+0...
<input type="checkbox"/> Nylon 6/10	Plastics	1500	1400	8.3e+009	0.53	0.28		1.42559e+008
<input type="checkbox"/> PA Type 6	Plastics	1601	1120	2.62e+009	0.233	0.34		9e+007
<input type="checkbox"/> PBT General Purpose	Plastics	1421	1300	1.93e+009	0.2741	0.3902		5.65e+007
<input type="checkbox"/> PC High Viscosity	Plastics	1535	1190	2.32e+009	0.189	0.3912		6.27e+007
<input type="checkbox"/> PE High Density	Plastics	1796	952	1.07e+009	0.461	0.4101		2.21e+007
<input type="checkbox"/> Perspex (TM) GS Acrylic C...	Plastics		1190					7.5e+007
<input type="checkbox"/> PF	Plastics	1900	1400	2.41e+009	0.2618	0.3897		4e+007
<input type="checkbox"/> Polybutadiene (PB)	Plastics		970	2.07e+009	0.217		7.4e+007	2.7e+007
<input type="checkbox"/> PBTP	Plastics		1310	2.38e+009	0.188		7.4e+007	5.34e+007
<input type="checkbox"/> PEI	Plastics	2000	1270	3.1e+009	0.22	0.44	1.4e+008	8.5e+007
<input type="checkbox"/> Polyester Resin	Plastics		1160	1.9e+010	0.17		2.3e+008	1.9e+008
<input type="checkbox"/> Polyetheretherketone (PEEK)	Plastics	1850	1310	3.9e+009	0.24	0.4	1.25e+008	9.5e+007
<input type="checkbox"/> PE High Density Film	Plastics		950	1.86e+009	0.48			3.1e+007
<input type="checkbox"/> PMMA	Plastics	1250	1190	2.77e+009	0.21		1.05e+008	6.1e+007
<input type="checkbox"/> POM Acetal Copolymer	Plastics	1378	1390	2.6e+009	0.221	0.3859		7.15e+007
<input type="checkbox"/> PP Copolymer	Plastics	1881	890	8.96e+008	0.147	0.4103		2.76e+007
<input type="checkbox"/> PPE	Plastics		1060	2.3e+009	0.22			5e+008
<input type="checkbox"/> PP Homopolymer	Plastics		933	1.79e+009	0.117		3.93e+007	3.3e+007
<input type="checkbox"/> PP Film	Plastics		908	1.53e+009				3.4e+007
<input type="checkbox"/> PS Medium/High Flow	Plastics	1691	1040	2.28e+009	0.121	0.387		3.59e+007
<input type="checkbox"/> PS HI	Plastics		1080	2.1e+009	0.251			2.4e+007
<input type="checkbox"/> PUR	Plastics	1900	1260	2.41e+009	0.2618	0.3897		4e+007
<input type="checkbox"/> PVC Rigid	Plastics	1355	1300	2.41e+009	0.147	0.3825		4.07e+007
<input type="checkbox"/> Sheet Moulding Compound	Plastics		1400	1.38e+009	0.071			1.38e+008
<input type="checkbox"/> SMA	Plastics		1070					3.54e+007
<input type="checkbox"/> Very Low Density PE (SS)	Plastics	1842	905	1.723689e+0...	0.322	0.3		3.4e+007

Environmental Impact

Carbon



Selected: 0.07
Original: 1

Energy



Selected: 1.44
Original: 1

Air



Selected: 2.89E-4
Original: 1

Water



Selected: 2.90E-5
Original: 1

Manufacturing Process: Injection Molded

Accept Edit Cancel Help

“Oh my gosh, that’s quite a list. I can toss a few of these because they’re too expensive, some because I just have no experience working with them, and some because they’re just plain silly for a cup.” Priscilla clicked the checkboxes to the left of the materials she wanted to keep, and then clicked the little Harry Potter-like glasses to the left of the “Materials” heading to sort the list.

Materials	Material Class	Specific Heat	Mass Density	Elastic Modul...	Thermal Con...	Poisson's Rat...	Compressive...
PET	Plastics	1140	1420	2.96e+009	0.261	0.37	9.29e+007
<input checked="" type="checkbox"/> ABS		1386	1020	2e+009	0.2256	0.394	
<input checked="" type="checkbox"/> ABS PC		1900	1070	2.41e+009	0.2618	0.3897	
<input checked="" type="checkbox"/> Acrylic (Medium-hi...		1500	1200	3e+009	0.21	0.35	
<input checked="" type="checkbox"/> PC High Viscosity		1535	1190	2.32e+009	0.189	0.3912	
<input checked="" type="checkbox"/> PE High Density		1796	952	1.07e+009	0.461	0.4101	
<input checked="" type="checkbox"/> PP Copolymer		1881	890	8.96e+008	0.147	0.4103	
<input checked="" type="checkbox"/> PP Homopolymer			933	1.79e+009	0.117		3.93e+007
<input checked="" type="checkbox"/> PS HI			1080	2.1e+009	0.251		

Environmental Impact

Carbon: Selected 0.07, Original 0.07

Energy: Selected 1.44, Original 1.44

Air: Selected 2.89E-4, Original 2.89E-4

Water: Selected 2.90E-5, Original 2.90E-5

Manufacturing Process: Injection Molded

Buttons: Accept, Edit, Cancel, Help

She then clicked on the first material to see its comparative impact. “Oh boy, ABS is a lot worse than the PET on all four indicators.”

Materials	Material Class	Specific Heat	Mass Density	Elastic Modul...	Thermal Con...	Poisson's Rat...	Compressive...
PET	Plastics	1140	1420	2.96e+009	0.261	0.37	9.29e+007
<input checked="" type="checkbox"/> ABS		1386	1020	2e+009	0.2256	0.394	
<input checked="" type="checkbox"/> ABS PC		1900	1070	2.41e+009	0.2618	0.3897	
<input checked="" type="checkbox"/> Acrylic (Medium-hi...		1500	1200	3e+009	0.21	0.35	
<input checked="" type="checkbox"/> PC High Viscosity		1535	1190	2.32e+009	0.189	0.3912	
<input checked="" type="checkbox"/> PE High Density		1796	952	1.07e+009	0.461	0.4101	
<input checked="" type="checkbox"/> PP Copolymer		1881	890	8.96e+008	0.147	0.4103	
<input checked="" type="checkbox"/> PP Homopolymer			933	1.79e+009	0.117		3.93e+007
<input checked="" type="checkbox"/> PS HI			1080	2.1e+009	0.251		

Environmental Impact

Carbon: Selected 0.21, Original 0.07

Energy: Selected 2.87, Original 1.44

Air: Selected 2.05E-3, Original 2.89E-4

Water: Selected 1.11E-4, Original 2.90E-5

Manufacturing Process: Injection Molded

Buttons: Accept, Edit, Cancel, Help

Priscilla continued down the materials, and began to worry that she wouldn't find a more sustainable material. She got down to polypropylene homopolymer, and rejoiced upon seeing green bars on all four indicators:

Materials	Material Class	Specific Heat	Mass Density	Elastic Modul...	Thermal Conducti...	Poisson's Rat...	Compressiv
PET	Plastics	1140	1420	2.96e+009	0.261	0.37	9.29e+00
<input checked="" type="checkbox"/> ABS		1386	1020	2e+009	0.2256	0.394	
<input checked="" type="checkbox"/> ABS PC		1900	1070	2.41e+009	0.2618	0.3897	
<input checked="" type="checkbox"/> Acrylic (Medium-hi...		1500	1200	3e+009	0.21	0.35	
<input checked="" type="checkbox"/> PC High Viscosity		1535	1190	2.32e+009	0.189	0.3912	
<input checked="" type="checkbox"/> PE High Density		1796	952	1.07e+009	0.461	0.4101	
<input checked="" type="checkbox"/> PP Copolymer		1881	890	8.96e+008	0.147	0.4103	
<input checked="" type="checkbox"/> PP Homopolymer			933	1.79e+009	0.117		3.93e+00
<input checked="" type="checkbox"/> PS HI			1080	2.1e+009	0.251		

Environmental Impact

Carbon: Selected 0.04, Original 0.07

Energy: Selected 0.99, Original 1.44

Air: Selected 1.91E-4, Original 2.89E-4

Water: Selected 1.90E-5, Original 2.90E-5

Manufacturing Process: Injection Molded

Buttons: Accept, Edit, Cancel, Help

"That's great!" she said, but then she thought about the other engineering properties. "Darn, I'd really like to use something that has similar insulating properties as PET, and the conductivity of PP is pretty different," she said to Tom. "But the last remaining choice is High-Impact Polystyrene, and everyone knows how bad that is. Polystyrene is what they make Styrofoam from, after all."

"Try it anyway?" said Tom. "It has a similar conductivity to your PET."

Without expecting much, Priscilla clicked on the "PS HI" material and was surprised to find:

Materials	Material Class	Specific Heat	Mass Density	Elastic Modul...	Thermal Conducti...	Poisson's Rat...	Compressiv
PET	Plastics	1140	1420	2.96e+009	0.261	0.37	9.29e+00
<input checked="" type="checkbox"/> ABS		1386	1020	2e+009	0.2256	0.394	
<input checked="" type="checkbox"/> ABS PC		1900	1070	2.41e+009	0.2618	0.3897	
<input checked="" type="checkbox"/> Acrylic (Medium-hi...		1500	1200	3e+009	0.21	0.35	
<input checked="" type="checkbox"/> PC High Viscosity		1535	1190	2.32e+009	0.189	0.3912	
<input checked="" type="checkbox"/> PE High Density		1796	952	1.07e+009	0.461	0.4101	
<input checked="" type="checkbox"/> PP Copolymer		1881	890	8.96e+008	0.147	0.4103	
<input checked="" type="checkbox"/> PP Homopolymer			933	1.79e+009	0.117		3.93e+00
<input checked="" type="checkbox"/> PS HI			1080	2.1e+009	0.251		

Environmental Impact

Carbon: Selected 0.05, Original 0.07

Energy: Selected 1.03, Original 1.44

Air: Selected 2.22E-4, Original 2.89E-4

Water: Selected 2.34E-5, Original 2.90E-5

Manufacturing Process: Injection Molded

Buttons: Accept, Edit, Cancel, Help

“Holy green bars!!” Priscilla proclaimed. “HIPS is a greener material on all four indicators, compared to PET. Who would have thought it!”

“Careful,” said Tom, “you know there’s no such thing as a miracle material. Still, in this application, it looks like HIPS is the best material you can use.”

Priscilla clicked Accept, and then clicked the Set Material button in the Sustainability pane to set her part to High-Impact Polystyrene.

Material

Class: Plastics

Name: PS HI

Weight: 0.03 lbs

Buttons: Find Similar, Set Material

“Sustainability isn’t just about the material choice,” said Tom. “Is there something you can do to redesign the geometry of the cup to use less material?”

Priscilla thought about that. “Hmm, let’s see. I could make the cup really tall and skinny, or wide and squat; I wonder what that does to the environmental impact?” She reset the Baseline by clicking once to release it, and again to set it to the new material.

Priscilla, being a relative SolidWorks novice, figured that the easiest way for her to model the volume was in a separate part. She opened a new SolidWorks document, made a quick sketch with the rough shape and dimensions of the cup, and revolved it as a solid. A quick check of the Mass Properties told her the volume of the cup, and she could play with the dimensions of the solid through trial and error to match the volume of her cup.

“Let me try making the cup extremely tall and skinny, or really wide and short.” She figured out the dimensions to match the volume, and then edited the sketch in her Cup model to have a bottom radius of 0.50, a top radius of 0.75, and a height of 30 inches. After they both laughed, Priscilla excited the sketch and checked the Sustainability dashboard—all the gains from changing material would be lost, as she was actually above the original PET baseline, now at 0.08 kg-eq CO₂ and 1.91 MJ energy, with similar increases in air and water effects.

Next, Priscilla tried the opposite—she changed the dimensions to a bottom radius of 2.90, a top radius of 3.50, and a height of 1.15. After another giggle, Priscilla saw that this was also worse than the baseline at 0.07 kg-eq CO₂ and 1.50 MJ of energy.

“Hmm, it seems that short and wide or tall and narrow are both worse. Perhaps the closer my cup gets to the ideal lowest surface-area-to-volume ratio—a globe—the less material it’ll use, and the lower impact it’ll be.” She tried a few new geometries, and found that using a bottom radius of 1.45, top radius of 2.50, and height of 3.00 inches would hold the same volume, AND yielded green bars all around: 0.04 kg-eq CO₂, 0.99 MJ energy, 2.12e-4 kg-SO₂ air impact, and 2.24e-5 kg-eq PO₄ water impact. The new cup design looked like this:

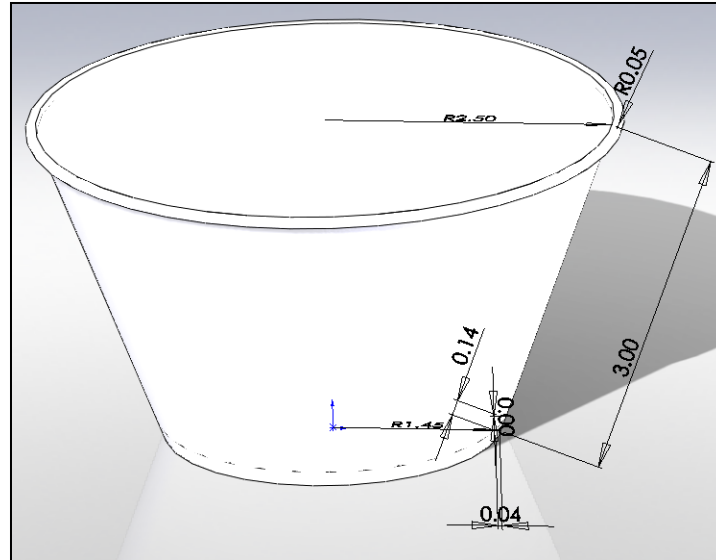

“It’s just a bit less impactful on all four indicators, but that will add up. I wonder how I did against the original model, with both the material and the geometry changes?” Priscilla clicked the “Import Baseline” button to the right of the “Set Baseline” button, and selected her original saved part file in which she had first set the Sustainability parameters using the old geometry and the PET material. The Sustainability dashboard now showed the cumulative effects of her model:

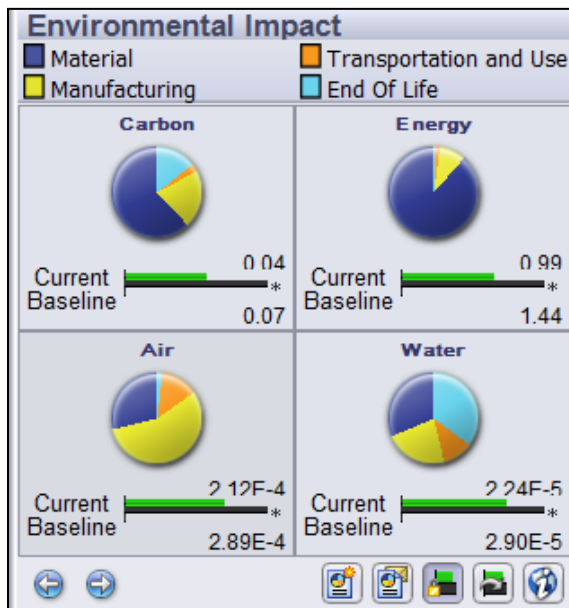

Priscilla's finished model is saved as `Guide_cup_finished.sldprt` in the collection of Chapter 5 files (`Guide_cup_files.zip`) at <http://www.solidworks.com/sustainability/training/learning-resources.htm>.

"Nice work. Let's see how you did comparing your functional unit," said Tom. Priscilla clicked the next button in the sequence, marked "Online Info". This launched the Sustainability Calculator, where Priscilla could type in her actual quantities to compare against several different metrics. She typed in 100 in each quantity box:

Carbon Footprint: Miles driving a Hybrid (based on Toyota Prius) Learn More

Design Type	Name	Value	Quantity	Impact
CURRENT DESIGN	Guide_cup_in_process.	0.044 kg CO ₂	100	Negligible
BASELINE DESIGN	Guide_cup_original_bas	0.070 kg CO ₂	100	Negligible

NEED TO UPDATE CALCULATION

CALCULATE = 0.05 Miles driving a Hybrid

Data Capture: 2 Dec 2010

Metric	European car	US car	Hybrid
Energy Consumption	Miles driving an average European car	Miles driving an average US car	Miles driving a Hybrid
Carbon Footprint			
Air Acidification			
Water Eutrophication			

She hit the "Calculate" button and explored the different ways that Sustainability could show the difference.

"This is fantastic!" she said. "I see a 31% reduction in Energy, a 38% reduction in Carbon, a 25% reduction in Water impacts, and my Air impacts become negligible. According to the guidelines for simple products, I can be pretty sure that mine is significantly more sustainable.

"So that's four of my five key indicators. I did want to measure the fifth impact domain of human toxicity, though. SolidWorks Sustainability doesn't seem to have any toxicity indicators... what's up with that?"

Why There Aren't Any Toxicity Indicators in SolidWorks Sustainability

The toxicity of a chemical—and its harmfulness to humans—is particularly dependent on the degree of exposure of the chemical, which is hard to track using LCA databases, as they track more global effects. After getting together to debate this very issue, group of the world's leading scientists and LCA practitioners—sponsored by the UN—decided that toxicity models so poorly predicted the real impacts that they shouldn't be used to guide business decisions until the models improved. They produced a document to this effect, called this the Declaration of Apeldoorn after the location of the meeting.

“Well I guess that makes sense,” said Priscilla. “I'm sure when the toxicity models become useful, they'll add them into SolidWorks Sustainability.”

Chapter 6: A Reconsidered Toy – Tom’s Turn

“Now let’s see what I can do for this more complex product! I actually have full Sustainability on my machine,” said Tom, “so let me fire it up in assembly mode with my toy model.”



Sustainability



Download the models from Chapter 6 (Guide_fire_engine.zip) at <http://www.solidworks.com/sustainability/training/learning-resources.htm> and open the model `Guide_fire_engine.sldasm` to play along with this example.

First, Tom went through each of his parts and made sure that each of the parameters—materials and locations—were set for each part. Then, Tom viewed Sustainability at the assembly level, and Priscilla saw a couple new options available:





Manufacturing ^

Region : Asia



Transportation and Use ^

Primary Mode of

Use Region : North America



Product Lifetime Energy
Type of energy:

None ▼

“The Manufacturing region is now specifying where the product is *assembled*, which adds a second transportation leg to each of the individual part manufacturing regions,” Tom explained. “And here, I can specify the primary mode of transportation of this second leg. As with your cup, my toy is assembled in Asia—though not all of the parts are manufactured there, as we discussed earlier—and used in North America, and sent across by ship.”

“And what’s that energy box?” Priscilla asked.

“That’s where I can specify how much energy is used by my product. It’s given in terms of the energy type consumed over the lifetime of the product—gasoline, diesel, electricity, etc. In my case, I assumed that my toy’s AA battery would be recharged from the grid ten times.”

Tom pulled up some figures for AA batteries. “Let’s see,” he said. “An AA battery has a capacity of 2500 milliamp-hours (mAh) at just over a volt, so that’s about 3 watt-hours (Wh) per battery. Ten battery recharges would draw 30 Wh, or 0.03 kWh over the lifetime of the toy.” He entered this value into the Product Lifetime Energy input parameter:

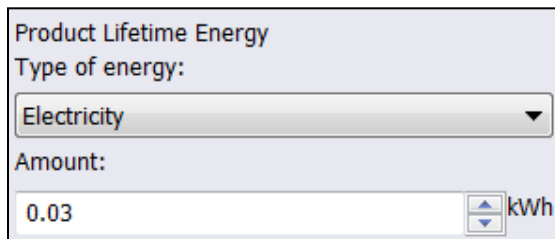

The image shows a software dialog box titled "Product Lifetime Energy". It contains a "Type of energy:" label followed by a dropdown menu with "Electricity" selected. Below this is an "Amount:" label followed by a text input field containing "0.03" and a unit selector dropdown set to "kWh".

Finally, Tom baselined these parameters and looked at the results:

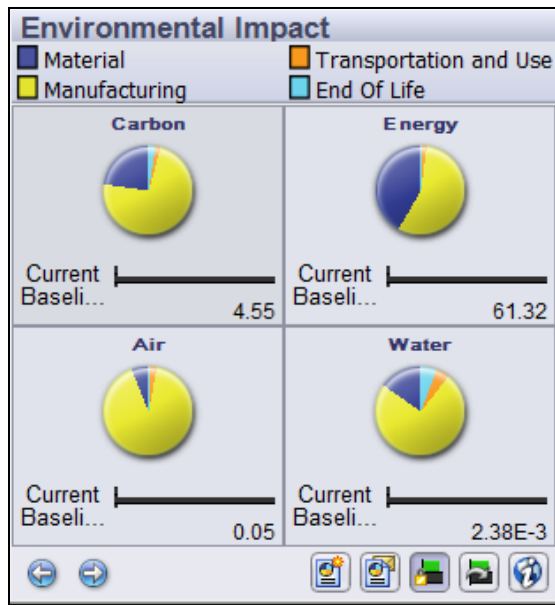

“You know, I’m surprised at what the charts are showing me,” he said to Priscilla. “I expected the power draw to significantly impact the Transportation and Use phase, but as you can see it’s really pretty negligible. I guess it isn’t hypocritical to be trying to make a lower-carbon battery-powered toy. That’s encouraging!”

“What I *am* seeing,” he continued, “is that the materials, and the manufacturing process associated with these materials, constitute the bulk of the impacts.”

“Which ones, though?” asked Priscilla. “This toy has a lot of different parts of different materials.”

“I know, and I don’t want to open each one to look at its individual Sustainability results. Let’s look at this through the Assembly Visualization tool.”

Tom opened Assembly Visualization, which Priscilla had seen used before for viewing components by, say, total weight. Tom showed her how he could add a custom column for any of the Sustainability metrics:

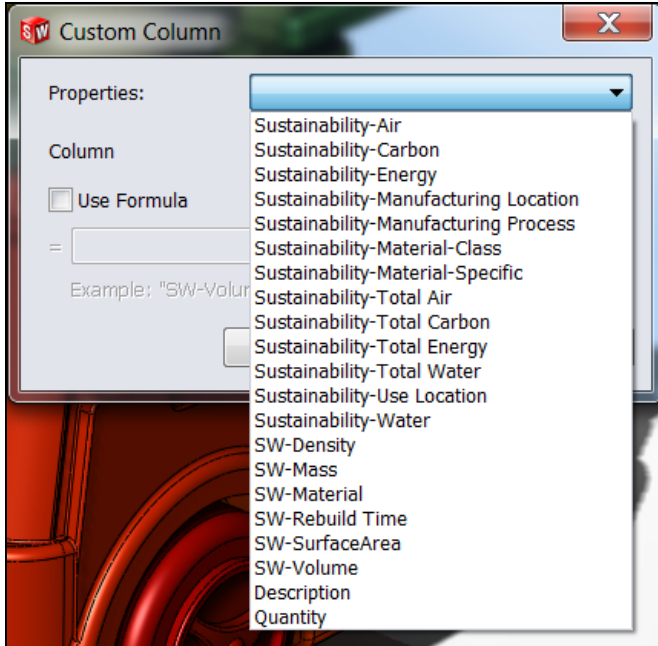

Since Tom wanted to get an estimate of his carbon footprint, he wanted to use one of the carbon properties. He chose “Total Carbon”, which groups together multiple instances of parts, to view for instance the effect of all four wheels together. He added this column and clicked on it to sort the parts by this indicator. Finally, Tom set the visualizing spectrum to meaningful colors and moved the slider to an appropriate cutoff:

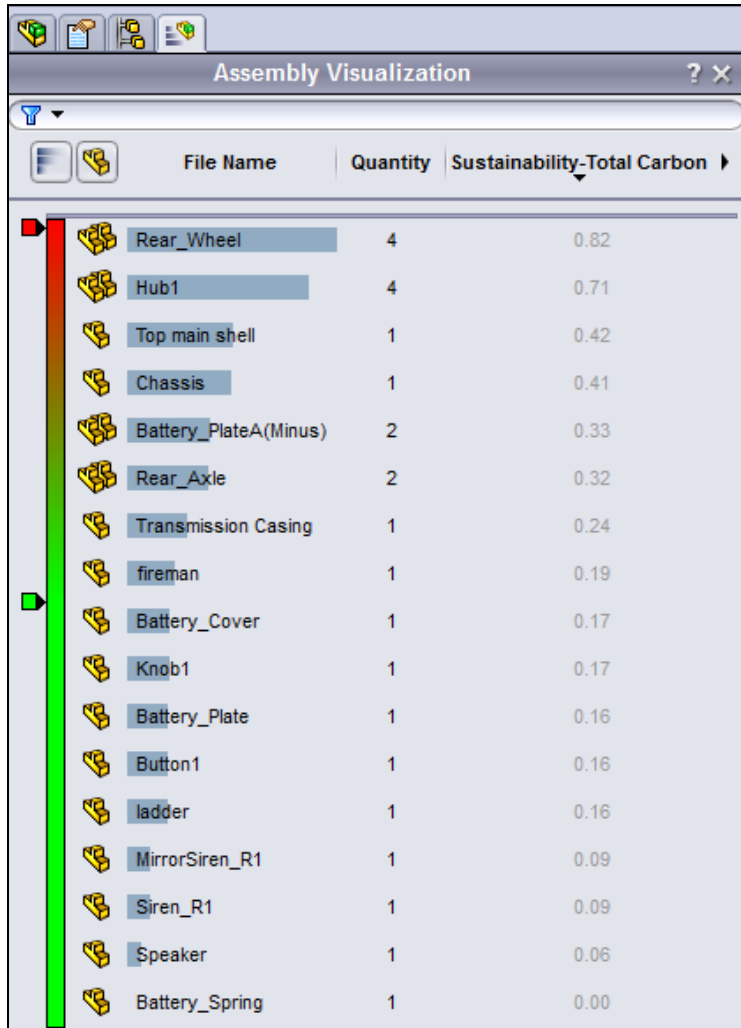

File Name	Quantity	Sustainability-Total Carbon
Rear_Wheel	4	0.82
Hub1	4	0.71
Top main shell	1	0.42
Chassis	1	0.41
Battery_PlateA(Minus)	2	0.33
Rear_Axle	2	0.32
Transmission Casing	1	0.24
fireman	1	0.19
Battery_Cover	1	0.17
Knob1	1	0.17
Battery_Plate	1	0.16
Button1	1	0.16
ladder	1	0.16
MirrorSiren_R1	1	0.09
Siren_R1	1	0.09
Speaker	1	0.06
Battery_Spring	1	0.00

“There,” said Tom. “Now I can see pretty clearly what the most impactful parts are in my model.” He showed Priscilla the resulting color-coded assembly:



“From the sorting and the model, I can clearly see that the wheels and the wheel hubs are the main parts that I should focus on when I redesign my toy. In fact, I know that there are a lot of materials that are less impactful than ABS, so I can lower the footprint substantially; and it’s great to know that working with my suppliers to see what different materials are available to me within the target cost-of-goods range will really make a difference, rather than looking at the transportation or the power use.

To make sure that Tom wasn’t missing any internal components that had significant impacts, Tom cross-sectioned the view to look inside:

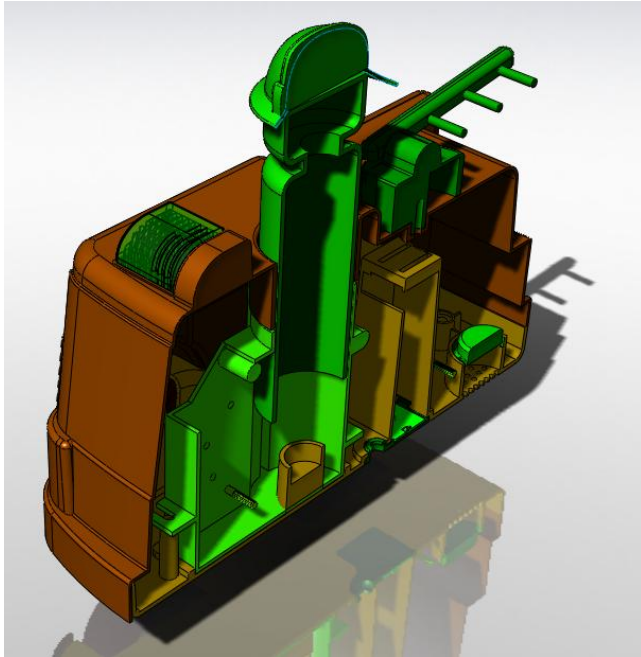

“Looks mostly green inside, so I know what I should focus on, and I have a quick sense of my carbon footprint. Now let me generate a report that I can take to the rest of my team to show them what I’ve found.”

Tom clicked the “Generate Report” button on the bottom of the Sustainability task pane.

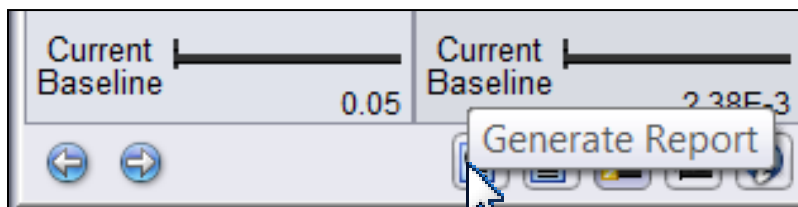

Tom then checked out a couple critical items in the report, such as a snapshot of the impact dashboard...

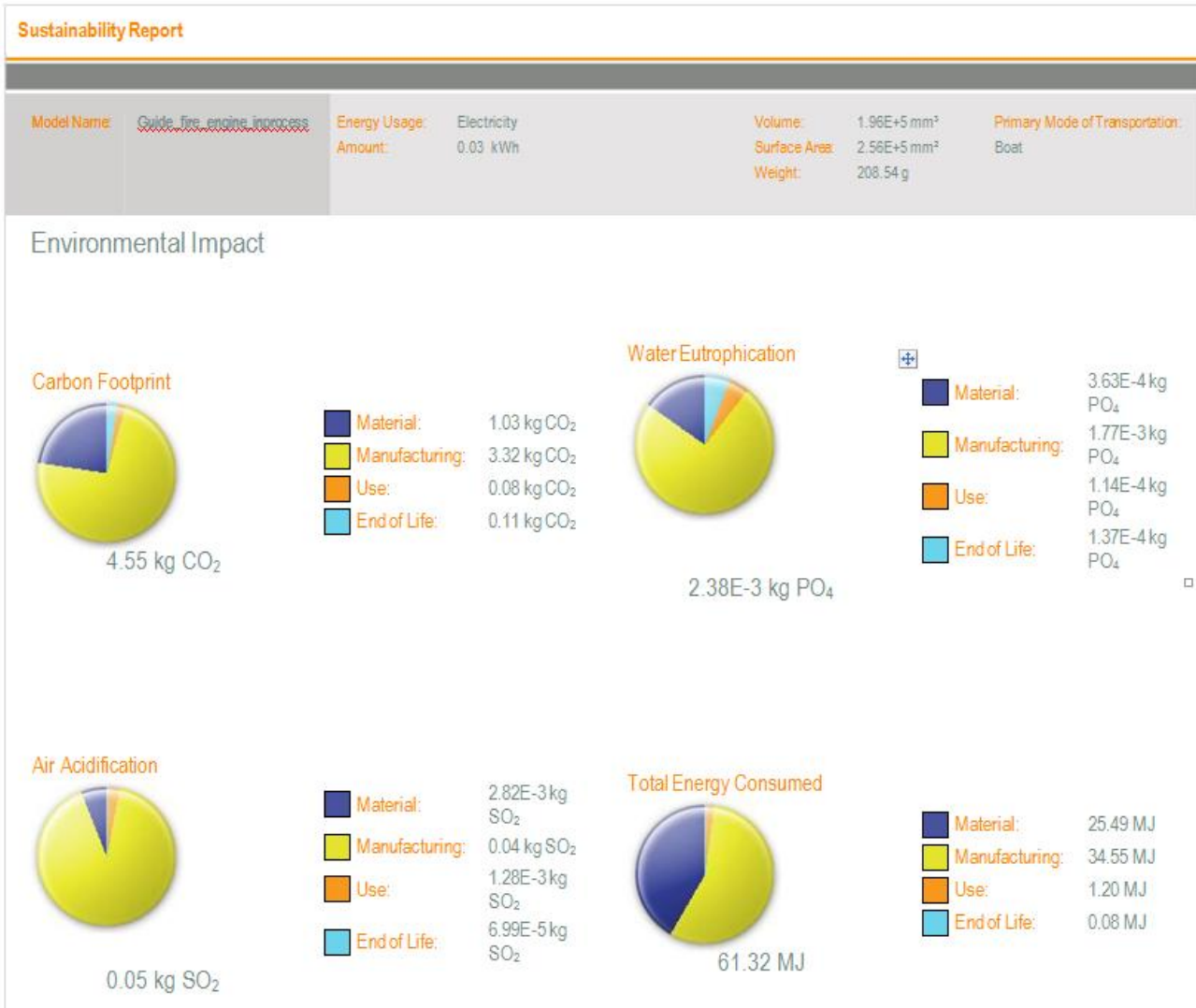

...And a look at the top three most impactful components:

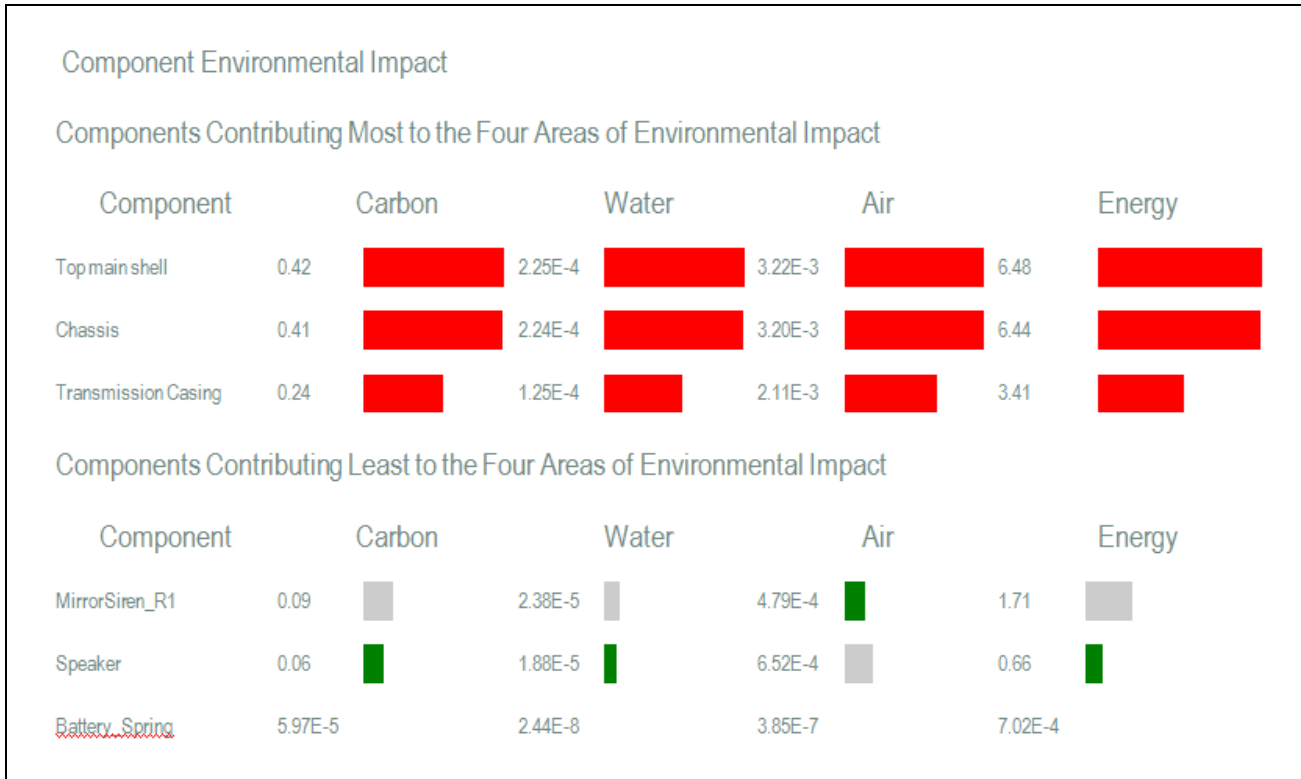

You can download Tom’s full sustainability report , titled **Sustainability Report - Fire_Engine_SLDASM(Default).doc**, from the SolidWorks Sustainability website at:
<http://www.solidworks.com/sustainability/training/learning-resources.htm>.

Tom explained, “This information gives me a screening-level look at the starting point for redesigning my toy, as well as ballpark figures of what I’ll eventually be able to use in my marketing, once I perform a full Life Cycle Assessment on the redesigned product.”

And with that, Tom and Priscilla started redesigning the toy fire engine. Can you come up with a lower carbon number than the final design they were able to produce?

Chapter 7: The Sustainable Design Strategies

Looking at impacts in the context of lifecycle phases is a good way to measure them, but not as helpful when actually designing or redesigning; after all, sustainable design strategies often affect more than one lifecycle phase.

Impact Level and Scope

When we talk about sustainable design strategies, we often talk about three levels of potential impact of a product redesign: *optimizing* an existing product system, *altering* the existing system, and designing a *completely new* system. These levels aren't clearly distinct (they overlap at the edges), and several design strategies can be used on multiple levels, but they're still useful to roughly categorize the level of impact we're discussing.

The first level, optimizing an existing system, is all about modifying the product's physical attributes—dimensions, geometries, locations, etc. Since CAD software is so good at such parametric optimization—provided there's a tool to measure the environmental impacts—we've had Tom and Priscilla focus on many of these aspects throughout this initial Guide. As an analogy we can use to compare the three levels, think of *optimizing an existing system* for an automobile: this might involve improving aerodynamic structure and reducing component weights to improve the fuel economy.

The second level is referred to as altering an existing system. Here, we're beginning here to think "outside the box" of the current system, but not scrapping it altogether. Continuing our automobile analogy, a hybrid-electric vehicle, such as a Toyota Prius, Honda Insight, or Ford Escape Hybrid, is a good example of a design change at this level. We are fundamentally altering the product itself, but still working within the overall auto infrastructure. Our redesign may alter people's driving behaviors—in fact, we hope it does!—but it doesn't rely on a fundamental, long-term shift in people's behaviors for its adoption.

Redesign at the third level, designing a completely new system, does rely on more long-term decisions and effects. In this case, a fully-electric vehicle, such as the new Nissan Leaf, is one such example; others include fuel cell cars or personal rapid transport (PRT). (The Chevy Volt is a plug-in hybrid electric vehicle, so it effectively spans levels two and three.)

How do we determine what level of redesign we should aim for? It's best to start with a target level of impact and the product system scope available for change. A redesign project may have a narrow scope, only allowing for, say, changes in material type. Conversely, a new product development effort may have a clean slate where the whole product-system is up for grabs. In current sustainable design practice, the level of impact is typically stated as a reduction from a reference, such as an existing design, e.g. the new design must have a 50% lower carbon footprint than the current one (a "factor 2" reduction is the terminology in the sustainable design field). However, as design practice improves, the target level should be stated in absolute, and not

relative, environmental measures. These product innovation curves show the relationship between the levels of redesign and the factor reductions³¹:

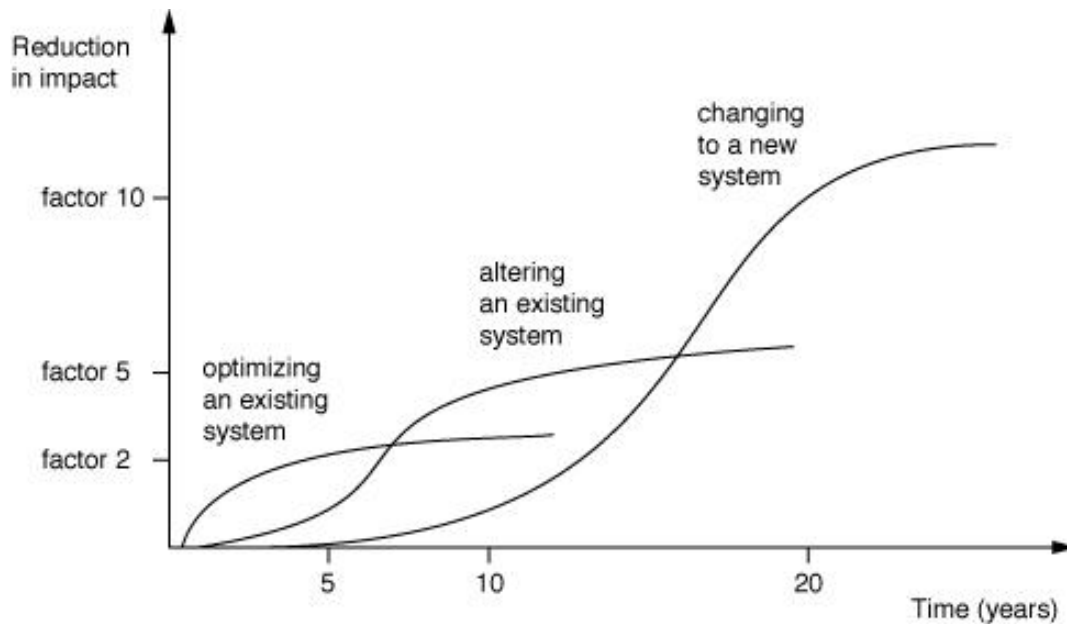

The level of impact reduction potential over the current performance and the scope of a design effort are interrelated, with the least reduction possible for the most narrowly scoped project, and the greatest reduction possible with the most broadly scoped. Innovating a new product concept provides much more opportunity than optimizing or even redesigning an existing product. *Backcasting* is a technique that involves creating a transition plan by working from a desired future outcome back to a present situation, and is a useful tool for guiding the innovation of new product-systems that achieve a high level of impact reduction over an extended period of time³².

Priscilla's and Tom's scope for change allows for the consideration of innovations at the first two levels, system optimization and alteration. That means that Priscilla and Tom have the potential to see factor 2 to factor 5 improvements (impact reductions) when they can fully explore all of the reduction strategies that are within their scope of change. We've focused in these initial examples on system optimization, that is, taking specific steps to incrementally reduce material and energy impacts. This often results in quick, low-hanging-fruit reductions in the overall product impact. Recall that Priscilla saw impact reductions from 25% to 38%, well on the way to reductions in the factor 2 ballpark with just the few strategies she initially tried.

Let's look at a few of the strategies that Priscilla and Tom explored from the first two levels, *optimizing* and *altering* their respective product systems.

³¹ Adapted from RAND Europe, Technologieradar, The Hague, The Netherlands: RAND Europe for the Dutch Ministry of Economic Affairs, 1997; and Weterings R, editor, 81 Mogelijkheden voor duurzame ontwikkeling [81 Options for sustainable development], The Hague, The Netherlands: Ministry of the Environment, 1997.

³² Dreborg, K. H., 1996. Essence of Backcasting, Futures, 28, 813-828.

Optimizing an Existing System

Sourcing Locally

Priscilla's first attempt was to *source locally* by moving the manufacturing operation closer to the region of use. As she found out, this is often highly dependent on the modes of transportation being compared, not just the distances involved. Generally speaking, the modes of transportation listed in decreasing order of environmental impact are:

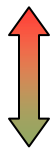
- 
1. Air transport
 2. Truck transport
 3. Rail transport
 4. Ship transport

Besides distance and mode, another transportation factor is the quality of the fuel used, which is also regionally dependent. Fuel sourced in Asia often has higher sulfur content, for example, raising the acidification potential of the transport leg. SolidWorks Sustainability assumes that the fuel is sourced in the region of origin for each transportation leg.

The transportation impacts of changing the manufacturing region may be outweighed by the regional differences in manufacturing, however. Manufacturing energy—in the form of thermal energy (natural gas, steam generation, etc.) and electrical energy—vary in amounts, efficiencies and sources in different regions. The grid mix in the region of manufacture has an impact on the energy and other indicators in the Manufacturing phase.

Lower-Impact Materials

Priscilla's second tactic was to make *a lower-impact material selection* for her cup. Materials that designers and engineers select should satisfy four criteria:

- The material must *function* as intended;
- The material must provide the right aesthetic, ergonomic, and other *form* considerations;
- The material's *cost* must be in the range of the product's cost of goods; and
- The material's *environmental impacts* should be minimized.

Too often, we optimize for the first three criteria and ignore the fourth. Priscilla worked through the “Find Similar” material selection tool to find a material that satisfied all four criteria.

Priscilla was quite surprised to find that High-Impact Polystyrene (HIPS) satisfied the criteria, including lower environmental impacts, than her original PET. Sometimes our assumptions about materials—like polystyrene, PVC, or various metals—are based more on negative press than on scientific data. By working with data-driven tools like SolidWorks Sustainability, we can sharpen our intuitions about material impacts.

Lightweighting

Finally, Priscilla re-examined the geometry of the cup to see if she could use less material to hold the same volume of liquid. *Lightweighting* is one of the most common ways to optimize for greener designs, especially since it often reduces material costs as well. This is a good example of a strategy that affects multiple phases. When less material is required at this product manufacturing phase, that means less material needs to be extracted, processed, and shipped prior to this phase;

these lightweighting effects multiply at each upstream phase. To look at a simplified example of this effect, if we assume a 5% scrap/waste rate at each phase, then each kilogram of material eliminated at the fourth phase means 1.2 kg reduced at the first phase—it's like compounding interest for the environment.

One critical consideration for load-bearing materials that are being lightweighted is to ensure that the product still has enough strength to perform as intended, within an appropriate factor of safety. SolidWorks has powerful Simulation tools that can be used in concert with Sustainability to optimize strength and reduced impact, and we'll explore this kind of optimization in future examples.

One final note on these strategies: it's important to realize that the strategies outlined here don't necessarily "belong" to the "Optimizing an Existing System" level. Priscilla chose these strategies because they were within the scope of the design changes she could make, given the scale of her project. Many strategies can be used at multiple levels of redesign.

Altering an Existing System

Tom and Priscilla realize intuitively that there is more to designing for sustainability than just optimizing an existing system.

Tom struggled with this level of redesign in the discussions of his functional unit and system boundary. He wanted an "interactive toy", but is a battery-operated speaker and lights the only way to achieve interactivity? What happens to the environmental impact if the parent replaces the ten uses of the rechargeable battery with ten disposable batteries—would drawing electrochemical juice from the batteries be "dirtier" than drawing electrical power from the grid? And what of the batteries' comparative impacts at end-of-life? Tom is realizing that people are an important part of all product systems, and that their behaviors determine the ultimate resulting impacts, making them an important consideration in sustainable design.

Tom realized that he could alter his product so that it isn't battery-operated, but still interactive. The only way to know if he should focus his efforts on the battery would be to include it in the environmental impact calculations.

In any case, Tom is on to a particularly good way of reduce the amount of materials and energy a product system uses: by checking to see how well it *fits the needs* of its users. Any mismatch here often results in systemwide over-use, resulting in an overdesigned product. He needs to find out if a toy that isn't battery-operated can still meet a child's interactivity needs. He could investigate altering the design to include a pull chord, or additional moving parts so that one or two children could play with it, meeting the needs of multiple children without the use of multiple toys.

Tom can also employ the lightweighting strategy here at this design level, by answering the question, "What's the smallest toy that still delivers the interactivity?"

We'll talk about ways to model these decisions when we revisit Tom's fire engine.

Priscilla thought early in the process about the system in which she was producing her cup. She felt that a plastic cup wasn't strictly necessary in all situations, and that perhaps altering her system to involve a reusable metal cup would mean a lower overall impact if more people were to adopt the practice of carrying or offering these. We'll take a look at this system redesign to *extend the life* of her product in the future, and consider how to compare these two models and their associated behaviors.

Quantity and Quality

Let's make some generalizations about Tom's and Priscilla's strategies. Typically, most eco-design strategies involve reducing the quantity or increasing the quality of material and energy use—or, ideally, both.

In fact, Priscilla could achieve both quantity- and quality-improvement outcomes by *specifying recycled materials*. This choice is actually two strategies in one: recycling involves closing the material loop and eliminating the material and energy spent during extraction (quantity), as well as using an alternate, lower-impact material (quality).

The quantity reduction that results from recycling can easily be seen in a type of *Sankey diagram* that shows the effect of closed-loop material cycling. Generically, this effect looks like this, with small material flows into and out of the system, and a large amount of material continuously cycling throughout the system:

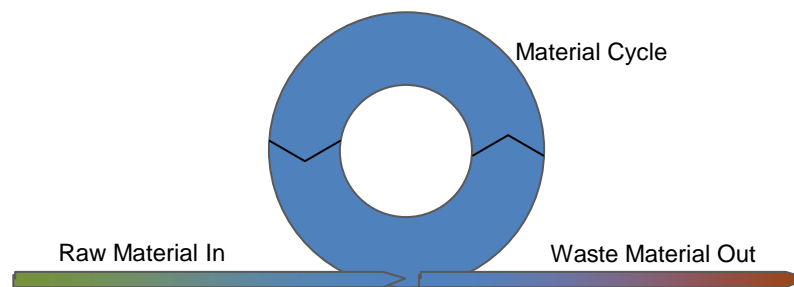

Here's a specific case of this kind of Sankey diagram that shows quantified material flows to demonstrate the presence and value of recycling³³:

³³ *PET beverage bottle recycling – an integrated MFA and LCA*; Kuczenski & Geyer (Donald Bren School of Environmental Science and Management at UCSB); Presented at First Symposium on Industrial Ecology for Young Professionals (SIEYP), Tempe, AZ on May 17, 2009.

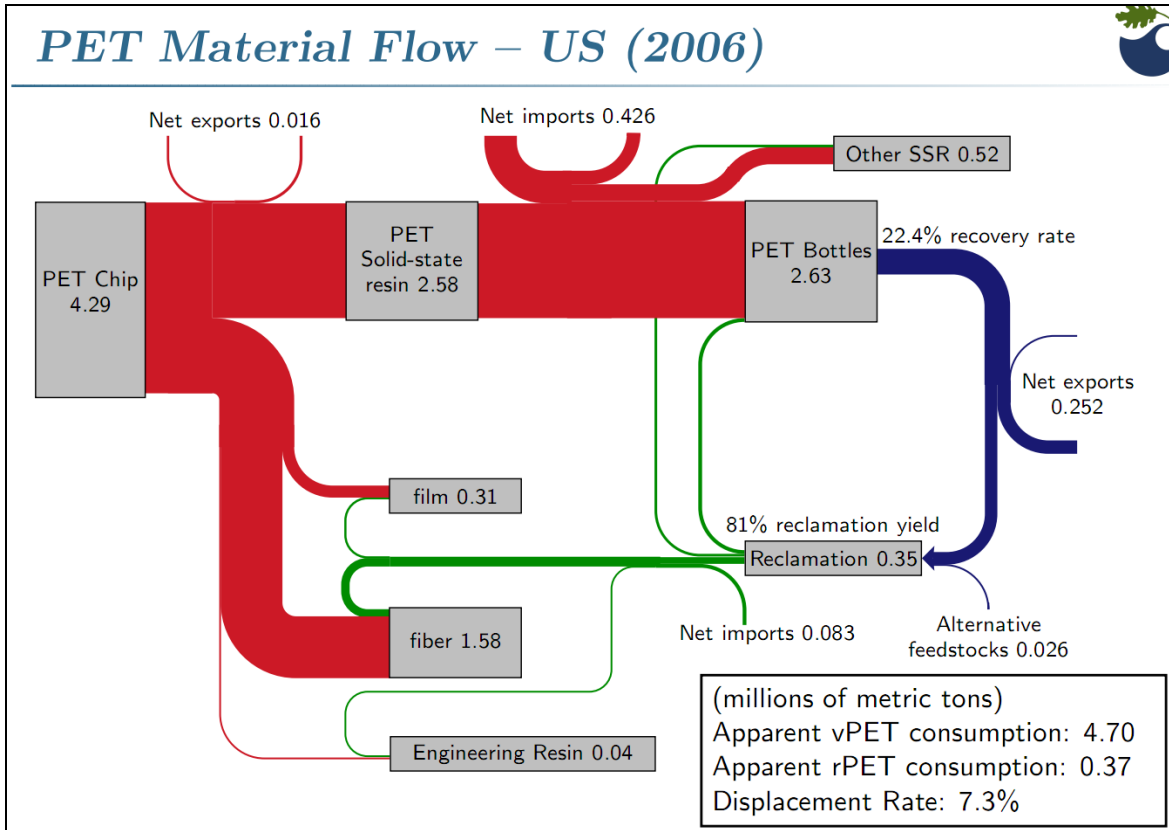

Recycled materials typically (but not always) involve fewer emissions than their virgin counterparts, and their use reduces the amounts that must be extracted from and deposited back into the environment. To take full advantage of this closed-loop effect, she should also alter her system to include recycling at the end of its lifecycle. Priscilla can't directly manipulate these closed-loop strategies in SolidWorks Sustainability, but we'll look at ways to model these effects in the future.

It's easy to get caught up with strategies that reduce quantity and forget about improving quality. As mentioned in the discussion of Environmental Indicators, Water is a good example of an indicator that requires strategies for both quantity and quality improvement. Water should be treated as a resource (quantity) that can be discreetly depleted, but it should also be treated as an overall source of "natural capital" that can be fouled by pollution (quality). Toxicity is another environmental metric that has both quantity and quality implications: the *quantity* of a toxic release is a good thing to track, but the *quality* of the release—in this case, different routes of exposure—can seriously vary the severity of the release. For example, releasing toxic compounds into a sensitive ecosystem is far worse than properly handling and treating toxics completely within an industrial "ecosystem".

Here's another example. In addition to reducing the amount of electricity his product uses, Tom could improve the quality by *using renewables* instead of fossil fuels. If he cannot control the electricity choice in the use phase, he can still consider the electricity required in all of the upstream phases that are more likely under his control.

Chapter 8: Communicating the Results

Product development is a process that touches many parts of an organization and its various partners and customers. Sustainable design can generate innovative and attractive solutions, but they may never see the light of day unless the features and benefits can be communicated effectively.

This section outlines some ways to communicate the value of sustainable solutions to several of the major stakeholders involved with most products.

To designers and engineers unfamiliar with sustainable design

As was discussed in the opening section of this guide, sustainability can mean many things to people. For perhaps the majority of designers it doesn't actually mean anything in particular. Then there are the engineers who have the impression that it is "touchy-feely," totally optional, not their problem, and/or too expensive.

Instead of trying to go through all of the aspects of sustainable design, describing functional units, midpoint categories, and so on, it is best to focus on common values. For instance, it may make more sense to talk about sustainable design as a set of tools designed to identify and decrease waste. This waste can come in the form of excess energy, pollutants, material ending up in landfills, and other non-valuable by-products generated over the life cycle of an item. Most environmental impact metrics actually represent explicit or inherent waste in the system, so comparing product designs can usually lead to the identification of lower waste options.

It may also help to use the environmental indicators tracked by a tool like SolidWorks Sustainability as a common language and set of metrics. Rather than calling one design "greener" than another, engineers may respond better if we refer to the design as having a 50% lower carbon footprint in kg of CO₂-equivalents, or having a 40% lower embodied lifecycle energy in MJ.

In certain sectors, sustainable design represents a way to incorporate regulatory considerations in the design process. When certain chemicals or materials can not be used, such as in the case of the EU's Restriction of Hazardous Substances Directive (RoHS), LCA tools can help identify useful alternatives that do not have the same hazardous impacts.

To general management

In a company with stated sustainability goals and policies

In an organization striving to be a sustainable company (see Chapter 2), sustainable design needs little explaining. In fact, in some cases there may be such lofty ambitions for sustainable design that the trade-offs identified by impact assessments need to be used to ground the conversation.

In companies where sustainability has become a focus, engineers have an excellent opportunity to engage with management around the goals and priorities that decisions about the products should

reflect. Some tools and approaches may fit better than others, depending on expected outcomes. For instance, an industry-wide scorecard will be more useful than an in-depth LCA if the purpose is to benchmark and communicate with other companies. Furthermore, there needs to be discussion about how to handle trade-offs between environmental impacts and other considerations, such as cost. These are business decisions, which are exactly what engineering and management need to navigate together.

In a company that has yet to ‘get religion’

Sometimes product developers will need to discuss sustainability with business people in the organization who either don’t understand it or who don’t think it is a priority. As with engineers, the key is to translate environmental impact considerations into terms that these people do care about. In the case of management, two great examples are profitability and risk management.

Sustainable design increases profit

Profit is the result of revenue minus cost. Therefore, anything that can be presented as either an increase in revenue or a decrease in cost will get people’s attention. Because most environmental impact studies do not show financial considerations, it may be necessary to extrapolate how more environmentally responsible products can increase revenue, perhaps through premium pricing or better competitive positioning. Cost reduction is an easier case to make since, as described above, excess environmental impacts are an expression of waste.

Sustainable design decreases risk

Environmental impacts also translate well into risks. The more that a company can do to decrease the negative impacts its products have on human health and the environment, the less likely to be unwanted repercussions for which the company could be held accountable. Of course, sustainable design doesn’t guarantee product safety—it is certainly possible to create environmentally-responsible but socially-*ir*responsible products (e.g., eco-designed baby toys can still be a choking hazard)—so design intelligence is still required. But linking impact decisions to risk management can help clarify the importance of sustainable design.

You can spend a lot of time optimizing a design for sustainability, but with an appropriately-scoped tool, the first-pass assessment shouldn’t take very long. Try handing in an “Environmental Impact Assessment” with your next product specs or models and see if it sparks an interesting conversation. Many times, curious managers will start asking questions about what the assessment measures, what parts of the life cycle it covers, and how to start reducing that impact—questions that you should now be equipped to start answering!

To other parts of the supply chain

In order to do a useful assessment, it is often necessary to get information from suppliers about the contents, processing techniques, manufacturing locations and so on for the components they provide. Sharing impact results with suppliers can help them adjust their own processes, or at least explain why the company is making certain sourcing and materials choices.

In some cases, organizations have the ability to demand that their suppliers abide by certain criteria. This can range from simply reporting their product's composition to full environmental impact assessments. For example, Walmart requires its suppliers to fill out a "Packaging Scorecard" as part of its efforts to reduce packaging throughout its supply chain, and they have recently developed a more comprehensive "Product Scorecard" as well. Although there aren't (yet) specific thresholds that their suppliers are required to meet, Walmart says that it will take the results into account in making sourcing decisions. Other well-known companies that require environmental scorecards from their suppliers include Procter & Gamble, McDonald's, and IBM.

Of course this works in reverse if the company doing the sustainable design is itself a supplier. By generating parts that take into account environmental impact, they are influencing the sustainability of downstream products. Sustainable design also makes it easier to comply with any impact requirements or guidelines the customer may have. For example, the sustainability initiatives of suppliers to retailers such as Timberland and Patagonia allow these companies to tell a more complete story of the improved environmental impact of their final products.

A common way to communicate impact data is through Environmental Product Declarations, or EPDs. EPDs are a standardized (ISO 14025/TR) representation of LCA results for a product. They require a full ISO-compliant LCA and build on the resulting quantified impact data certified by an independent third-party. EPDs are an internationally recognized format for presenting product LCA data, and not an evaluation or rating system. Generating EPDs is beyond the scope of tools like SolidWorks Sustainability, but is something that LCA experts like PE International have extensive experience with (*disclaimer: SolidWorks co-develops SolidWorks Sustainability in partnership with PE International*).

To sales & marketing

There are many times when information about the environmental impact of a product never reaches the customer. If it is not relevant to the product's purchase or use, the information can just stay "behind the scenes." However, there are two main reasons why impact information is shared with customers: to promote its sustainability as a specific product benefit, and to show that the product meets certain standards. In both cases, it is very important that sales and marketing people understand the regulations that apply to making environmental impact claims.

In the first case, it is often tempting to promote a product's sustainability using environmentally based marketing claims. So-called **green marketing** is on the rise, and many customers are starting to pay attention to environmental and social impacts in making buying decisions. Unfortunately, some organizations have gotten a little overzealous in their claims, often leading to accusations of *greenwashing*, or the use over-stated or unsubstantiated environmental marketing claims. As a result, the Federal Trade Commission has issued a set of Guides for the Use of Environmental Marketing Claims, known more commonly as the Green Guides. These guides lay out principles and guidelines to help marketers avoid making claims about environmental benefits that are considered unfair or deceptive, as defined by Section 5 of the FTC Act, and are currently being revamped to keep pace with this growing field of marketing.³⁴

³⁴ More information can be found at <http://www.ftc.gov/opa/reporter/greengds.shtml>

In brief, environmental claims have to be thoroughly vetted before being released to the public as marketing claims. In nearly all cases, this requires a *third-party verified LCA*. The “screening” tools discussed in Chapter 4—including SolidWorks Sustainability—aren’t strong enough to support public environmental claims. However, these tools can give you an idea of the story you’ll be able to tell, which can be verified to specific quantities by an LCA.

The second way in which environmental impact information is represented to customers is through criteria-based labeling programs. First, it is important to note that there are ISO standards in the 14000 family that apply to environmental labeling and life cycle assessment. These specify how LCA results can be used and what labeling can claim. In addition, there are many criteria-based certification programs for which products can qualify. Well-known examples include the US government’s [EnergyStar](#) program, the independent [FSC](#) label for lumber and paper products maintained by the Forest Stewardship Council, and [EPEAT](#) (Electronic Product Environmental Assessment Tool), a label for greener electronics.

Another important consideration in promoting the sustainability of a product is whether it is visibly “green” or whether its “greenness” is less apparent. A product that has an outer shell of bamboo, instead of plastic for instance, is in many ways its own advertisement. Hitachi SimpleTech’s “[re]drive” external USB hard drive has some good energy-saving capabilities designed into it, but the fact that its case is largely bamboo helps customers identify it as a “green” option right away. Meanwhile, in many situations, the best ways to reduce a product’s impacts are invisible to the user and need much more explicit advertising. For instance, the EnergyStar label can help identify products that use less power than their nearly identical-looking peers.

Chapter 9: Next Steps

Now what? Given all of the information in this guide, it might be hard to figure out exactly what to do, or do differently, on the proverbial Monday morning. Developing your skill in sustainable design will take some time, but there are plenty of ways to put these tools and techniques into practice immediately.

If your company or industry has any sort of sustainability scorecard, use it to assess your current design or an existing company product or component. If there isn't a specific scorecard that applies to your context, one like the 3M example given earlier or the LiDS Wheel can work. More important than getting it "right" at this point is determining what is difficult to score and what is more straightforward. Did you have enough information? If so, where did it come from and is it reliable? If not, how would you find it? Once you have done this for one product, do it for another one or for a design idea to get comfortable using these methods to compare options. If you are at a loss for examples use some general ones, such as glass bottles versus plastic ones, or paper bags versus plastic ones. A little research should turn up enough information about those products to get you started.

An easy place to start with data-based life cycle analysis is with the downloadable SolidWorks models, if you're a SolidWorks customer and user. If you have SolidWorks, you can use SustainabilityXpress for SolidWorks parts, since it's a standard component of the software.³⁵ There's value in learning to use the software, but more importantly, you can start to see the impacts that your various design decisions have on the environment. This is a good way to test your intuition as well. Are there environmental impacts from some materials that surprised you? Is there a greater or smaller difference between options than you would have thought? Most sustainable design entails narrowing down options and making trade-offs, so the more you have a basic feel for some of the impacts the easier it will be to find those changes that are meaningful and significant.

Once you have developed some familiarity with the concepts, frameworks, and design and decision support tools, it is important to incorporate them as often as possible, even when others aren't. There is nothing wrong with having greater insight into your products than is expected. Hopefully, however, you will be able to discuss the impacts and implications with your fellow designers as well as others in your organization and its partners.

For those who want to be acknowledged as proficient with SolidWorks Sustainability, there is a two-level certification program under development. You may be familiar with the traditional Certified SolidWorks Associate (CSWA) and Professional (CSWP) certifications; SolidWorks is developing analogous certifications for sustainable design, the Certified Sustainable Design Associate (CSDA) and Certified Sustainable Design Professional (CSDP). Stay tuned for more information—and if you've managed to read through to this section, rejoice in the fact that you're armed with enough knowledge to pass the CSDA!

³⁵ SustainabilityXpress is included starting in SolidWorks 2010. Users of SolidWorks 2009 can download it through the [SolidWorks Labs website](#).

If you are interested in becoming an LCA expert, there are numerous guides and courses that can develop the in-depth knowledge of the LCA process. Once you have gained hands-on experience, there is an exam-based qualification program developed by The American Center for Life Cycle Assessment for those interested in being designated as an LCA Certified Professional (LCACP). Note that the focus of this sort of LCA expertise is on assessment, and not on product design and development processes.

Lastly, try to connect with other developers, designers, and engineers working to incorporate sustainability principles into their work. There is a great deal of research about sustainable design available and underway, with plenty of academics interested in exploring the topic. There are professional networks and organizations around the world. There is a partial list at the end of this guide to get you started, but more are arising all the time. Whether you have come to this guide because you wanted to or because you had to, you will find that there are plenty of people who can guide you and resources that can help you succeed at sustainable design.

Chapter 10: For More Information

Appendix A – Reference materials

Sustainability & Sustainable Business

Berkshire Encyclopedia of Sustainability, Vol. 1-10, Berkshire Publishing Group (2009-2011)

www.EnvironmentalLeader.com

www.GreenBiz.com

www.SustainableLifeMedia.com

Sustainable Living

www.TreeHugger.com

www.inhabitat.com

www.grist.com

The Hannover Principles

Sections of this guide detail specific environmentally responsible design strategies. The “Hannover Principles” are a good place to start.³⁶ They are, in summary:

1. Insist on rights of humanity and nature to co-exist.
2. Recognize interdependence between the elements of human design and the natural world.
3. Respect relationships between the human values and matter.
4. Accept responsibility for the consequences of design decisions.
5. Create safe objects of long-term value.
6. Eliminate the concept of waste.
7. Rely on natural energy flows.
8. Understand the limitations of design.
9. Seek constant improvement by the sharing of knowledge.

For more information, see <http://www.mcdonough.com/principles.pdf>.

³⁶ Developed in 1992 by William McDonough and Michael Braungart for the Expo 2000 World’s Fair, Hannover, Germany.

Appendix B – A deeper look at the LCA process

The specific process of Life Cycle Assessment (LCA) has a standardized set of steps and outputs in the form of environmental impact measures.³⁷ It is defined as “an objective process to evaluate the environmental burdens associated with a product, process, or activity by identifying energy and materials used and wastes released to the environment, and to evaluate and implement opportunities to affect environmental improvements.”³⁸

The standardized LCA process has four major steps:

5. Goal and Scope Definition – *What are we trying to learn?*
6. Life Cycle Inventory (LCI) – *What’s embedded in the product?*
7. Life Cycle Impact Assessment (LCIA) – *What effects does it have?*
8. Data Interpretation – *What does it all mean?*

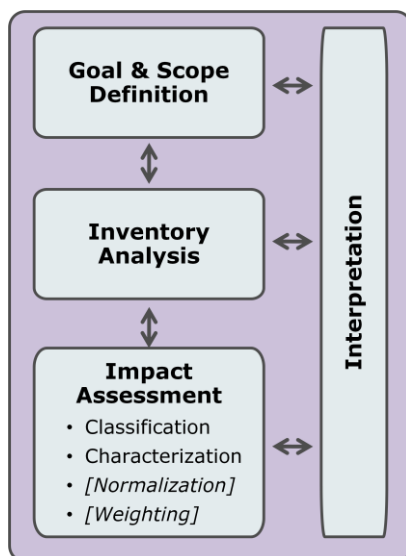

Goal & Scope Definition

As with other assessments, it is important to clarify the purpose and extent of the LCA. A Goal & Scope document will consider to the following questions.

1. What are we trying to understand?

LCAs are designed to address such questions as:

³⁷ LCAs are part of the ISO 14000 (environmental management) standards, and are specifically addressed by ISO 14040:2006 and 14044:2006.

³⁸ Society of Environmental Toxicology and Chemistry (SETAC), 1990

- What activities in the product's lifecycle contribute most to its overall environmental impact?
- What are the environmental consequences of changing a step in its production?
- What are the environmental consequences of changing the materials in the product?
- What are the environmental consequences of using recycled rather than virgin material for the product?
- What is the environmentally-preferable choice among products A, B or C?
- How does this product compare to its previous version?

LCAs usually do not address such things as social impacts or financial considerations so must be used in conjunction with other decision support tools.

2. What is the ***functional unit***?

In order to compare two product systems, it is necessary to choose a measure of the function of the systems that is consistent between the two. For instance, for a coffee maker it might be cups brewed, for laundry detergent it could be washing cycles, for paint it could be surface protection over time.

3. What ***environmental impacts*** should we consider?

A great deal of attention has been given to greenhouse gas emissions, with some organizations focusing mainly on their resulting carbon footprint, although this is just a subset of all of the possible environmental impacts that can be assessed. It is up to the organization to decide what factors are important to them.

4. What are we comparing?

LCAs are only useful when used to compare options. A given product can be compared to previous versions, competitive offers, alternative design options, industry benchmarks, target impact levels, etc.

5. What is our ***system boundary***?

Product life cycles intersect a great many processes, some more directly linked to the product itself than others. An assessment cannot cover everything so system boundaries clarify what it will include. The following figure shows a possible system boundary chart for a styrofoam cup.

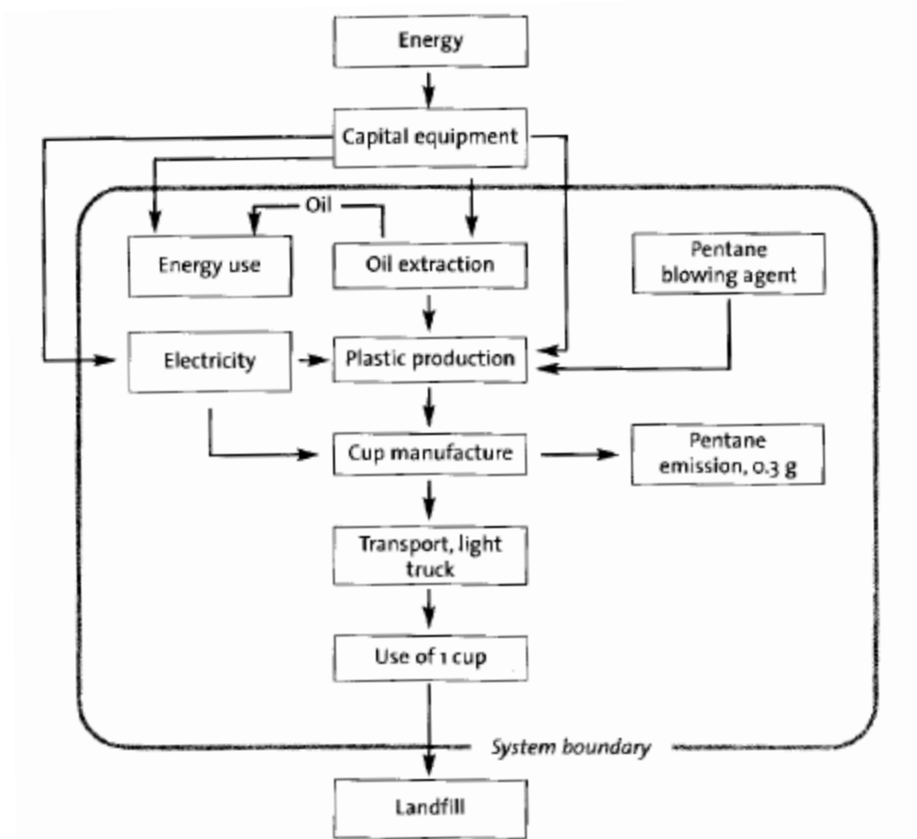

Source: *Design + Environment*, Lewis & Gertsakis

Some of the standard product life cycle scopes include:

- Cradle to grave – Usually denotes all phases from raw materials through disposal
- Cradle to cradle – Like cradle to grave except that it tracks where the product's elements go after end of use, with special attention to recycling and reuse
- Cradle to gate – Includes all phases up until it leaves production (the factory gate), bound for the customer, since this is the end of most manufacturer's ability to directly influence impact
- Gate to gate – A very narrow LCA, just focused on only one particular phase of the production process

6. What assumptions should we make?

Whether it's product usage behavior, availability of raw materials, manufacturing capacity, or any number of variables affecting a product's actual life cycle, LCAs require assumptions. They are unavoidable so the key is to identify and document them.

7. What are the data requirements and level of detail?

Data on actual product life cycles is more accurate, but much more expensive, labor intensive, and time consuming to collect than data from tables based on generalized information. The right balance depends on how the results will be used, as well as on data source access.

8. How do we allocate the burden of byproducts and other process complexities?

In many production processes, coupled or by-products occur, raising the question: To which product should these impacts be allocated? Assigning all the impacts to one product leads to “falsely benign” by-products. Methods for distributing multi-product impacts include allocating them by mass, energy value, market value, exergy, or substance content.

The depth and intensity of the LCA can be decided based on the answers to these questions. A “full” LCA would include actual environmental impact data gathered once the product has actually gone through its entire life cycle. Such detailed LCAs can take months and thousands of dollars to do and are, by definition, only possible to complete once the product is in use and has gone through all phases of its life cycle. This increased accuracy may be worth it for benchmarking or reporting purposes.

It is also possible to do an “LCA light,” using generalized data tables and educated assumptions about an item’s production and use. While not as accurate as LCAs reflecting actual impacts, they can be done relatively quickly and with a high degree of confidence in the results with the data sets and software tools available, even by people without in-depth LCA training. Perhaps most importantly, they can be done during product development and planning stages, allowing environmental impact considerations to play a part in design decisions.

Inventory Analysis

The next phase entails creating a list of all of the components of the products life cycle that fall within the defined system boundary. It has three major steps:

- Construct a process flowchart that shows the following:
 - Raw materials
 - Mfg processes
 - Transports
 - Uses
 - Waste management
- Collect data for:
 - Material inputs
 - Products and byproducts
 - Solid waste, air and water emissions
- Calculate the amounts of each in relation to the functional unit

The resulting Life Cycle Inventory (LCI) provides a breakdown of all of the energy and materials involved in a product’s system at a level of detail that provides a basis for evaluation.

Impact Assessment

Once a detailed LCI is created, environmental impacts can be ascribed to its parts, and if desired to the whole system. There are four steps to the Life Cycle Impact Assessment (LCIA) process, the first two of which are considered mandatory, while the last two are optional.³⁹

1. Classification

Classification involves assigning specific environmental impacts to each component of the LCI. It is here where decisions made during the scope and goal phase about what environmental impact categories are of interest come into play. The figure below shows one well-known set of classifications, called midpoint categories, and how they map to domains of damage they cause.⁴⁰

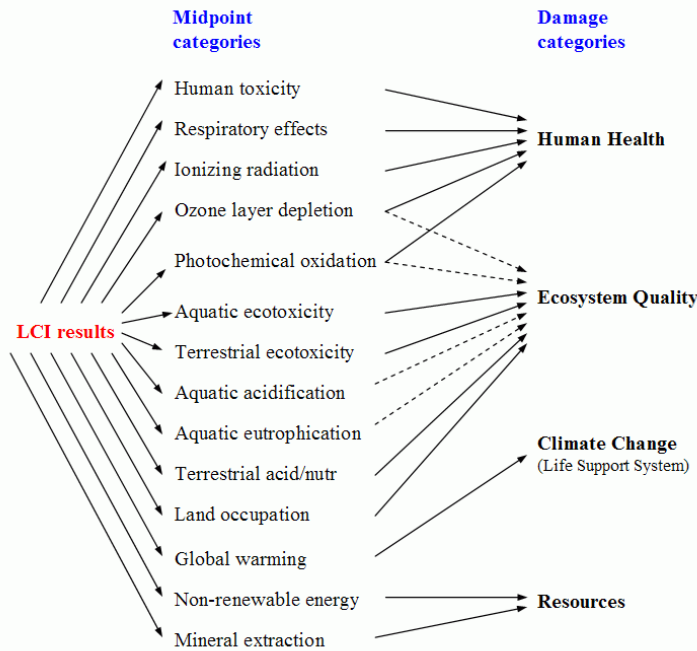

Commonly Used Life Cycle Impact Categories⁴¹

Impact Category	Scale	Examples of LCI Data (i.e. classification)	Common Possible Characterization Factor	Description of Characterization Factor
Global Warming	Global	Carbon Dioxide (CO2) Nitrogen Dioxide (NO2) Methane (CH4) Chlorofluorocarbons (CFCs) Hydrochlorofluorocarbons	Global Warming Potential	Converts LCI data to carbon dioxide (CO2) equivalents Note: global warming potentials can be 50, 100, or 500 year

³⁹ As dictated by the ISO 14044 standard

⁴⁰ "IMPACT 2002+" LCIA methodology / Dr. Olivia Jolliet, Univ. of Michigan
<http://www.sph.umich.edu/riskcenter/jolliet/impact2002+.htm>

⁴¹ "Life Cycle Assessment: Principles and Practice," Scientific Applications International Corporation, EPA/600/R-06/060 (May 2006), pg. 49.

		(HCFCs) Methyl Bromide (CH ₃ Br)		potentials.
Stratospheric Ozone Depletion	Global	Chlorofluorocarbons (CFCs) Hydrochlorofluorocarbons (HCFCs) Halons Methyl Bromide (CH ₃ Br)	Ozone Depleting Potential	Converts LCI data to trichlorofluoromethane (CFC-11) equivalents.
Acidification	Regional Local	Sulfur Oxides (SO _x) Nitrogen Oxides (NO _x) Hydrochloric Acid (HCL) Hydrofluoric Acid (HF) Ammonia (NH ₄)	Acidification Potential	Converts LCI data to hydrogen (H ⁺) ion equivalents.
Eutrophication	Local	Phosphate (PO ₄) Nitrogen Oxide (NO) Nitrogen Dioxide (NO ₂) Nitrates Ammonia (NH ₄)	Eutrophication Potential	Converts LCI data to phosphate (PO ₄) equivalents.
Photochemical Smog	Local	Non-methane hydrocarbon (NMHC)	Photochemical Oxidant Creation Potential	Converts LCI data to ethane (C ₂ H ₆) equivalents.
Terrestrial Toxicity	Local	Toxic chemicals with a reported lethal concentration to rodents	LC50	Converts LC50 data to equivalents; uses multi- media modeling, exposure pathways.
Aquatic Toxicity	Local	Toxic chemicals with a reported lethal concentration to fish	LC50	Converts LC50 data to equivalents; uses multi- media modeling, exposure pathways.
Human Health	Global Regional Local	Total releases to air, water, and soil.	LC50	Converts LC50 data to equivalents; uses multi- media modeling, exposure pathways.
Resource Depletion	Global Regional Local	Quantity of minerals used Quantity of fossil fuels used	Resource Depletion Potential	Converts LCI data to a ratio of quantity of resource used versus quantity of resource left in reserve.
Land Use	Global Regional Local	Quantity disposed of in a landfill or other land modifications	Land Availability	Converts mass of solid waste into volume using an estimated density.
Water Use	Regional Local	Water used or consumed	Water Shortage Potential	Converts LCI data to a ratio of quantity of water used versus quantity of resource left in reserve.

2. Characterization

Once the impact categories have been identified, conversion factors – generally known as characterization or equivalency factors – use formulas to convert the LCI results into directly comparable impact indicators. This allows different types of plastics and metals to be compared as to their impacts on Global Warming, for instance. The table above gives some commonly used characterization factors for each impact category.

There are well over a dozen categorization and characterization methods.⁴² Each maps materials to impacts based on scientific research, with many materials having impacts in multiple categories. Classification is usually facilitated by software that can take the component inputs and calculate allocated impacts based on either actual data gathered or standardized data tables. While there are pros and cons to each classification tool, some have been adopted more broadly than others.

3. Normalization (optional)

Some practitioners choose to normalize the impact assessment by scaling the data by a reference factor, such as the region’s per capita environmental burden. This helps to clarify the relative impact of a substance in a given context. For instance, if global warming contributions are already high in the context in which the product is being assessed, a reference factor would normalize whatever the product’s global warming contributions are in order to clarify its relative impacts.

4. Weighting (optional)

This process entails combining all of the indicators together, each with its own weighting, to create a single “score” that reflects a certain prioritization of the importance of each type of impact. Weighting is more of a political than scientific process since giving, say, global warming’s score more weight than acidification’s is a values-based decision. Stakeholders may differ significantly on their views about the importance of impacts, as shown in the chart below.⁴³

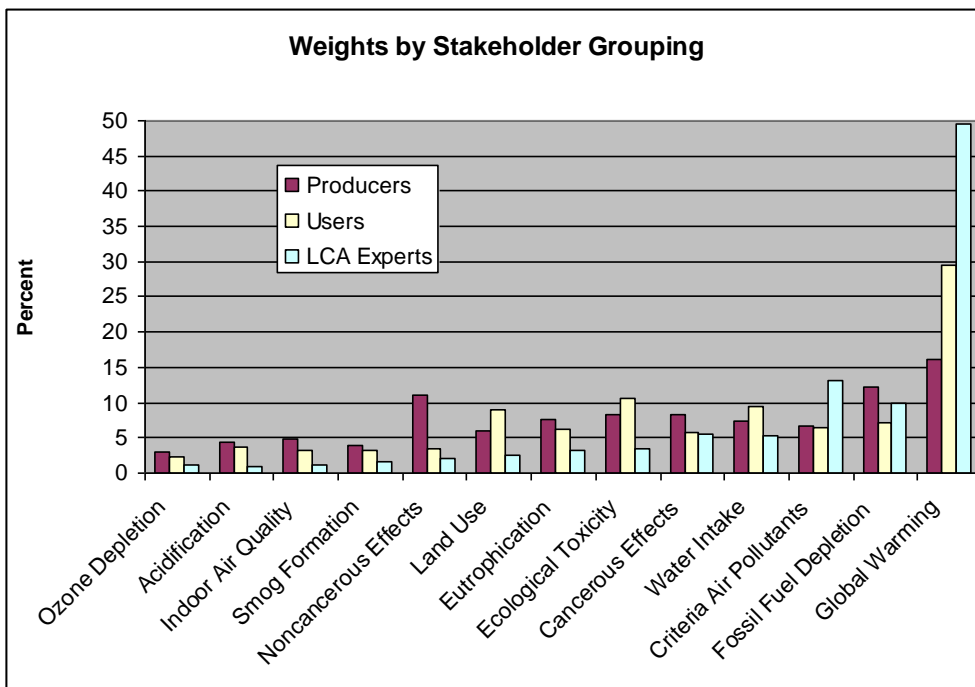

⁴² For a good overview of many of the major methods, see Appendix B: LCA and LCI Software Tools in “Life Cycle Assessment: Principles and Practice,” Scientific Applications International Corporation, EPA/600/R-06/060 (May 2006), pp. 74-77.

⁴³ Source: NIST, Tom Gioria?

Many practitioners choose to leave the impact scores broken out into categories, with no weighting at all. Although this approach creates a more complicated report, it enables impact comparisons between products on a more granular level.

Weighted “single score” LCAs have the advantage of generating one, easy-to-communicate impact number, often expressed as “millipoints.” However, even within the community that supports this approach there are two schools of thought. Some believe that there should be a standard weighting, while others feel that companies should be free to weight impacts as they see fit. One of the advantages of a standard weighting, as is used in the Okala approach among others, is that products can be compared to each other more easily since the single impact scores are only meaningful if compared among products with the same weighting. A second benefit is that companies can’t “game” the assessment to make their products look better than they are by emphasizing the areas in which the product does well and decreasing the effect of categories in which the product has problems.

The advantage of variable weighting approaches is that they can be customized to fit an organizations goals and values. For instance, if an organization is making global warming a priority, it may want to weight that category much more heavily as it is assessing the impacts of its products. As long as the weighting remains constant within its own LCAs, the disproportionate weight it gives to this category is fine. There are some sustainability accounting and reporting standards that focus almost exclusively on greenhouse gas emissions, making it useful for organizations using them to put almost all of the weight on that subset of impact factors.⁴⁴

⁴⁴ Carbon footprint standards such as PAS 2050 and the GHG Protocol fit this description.

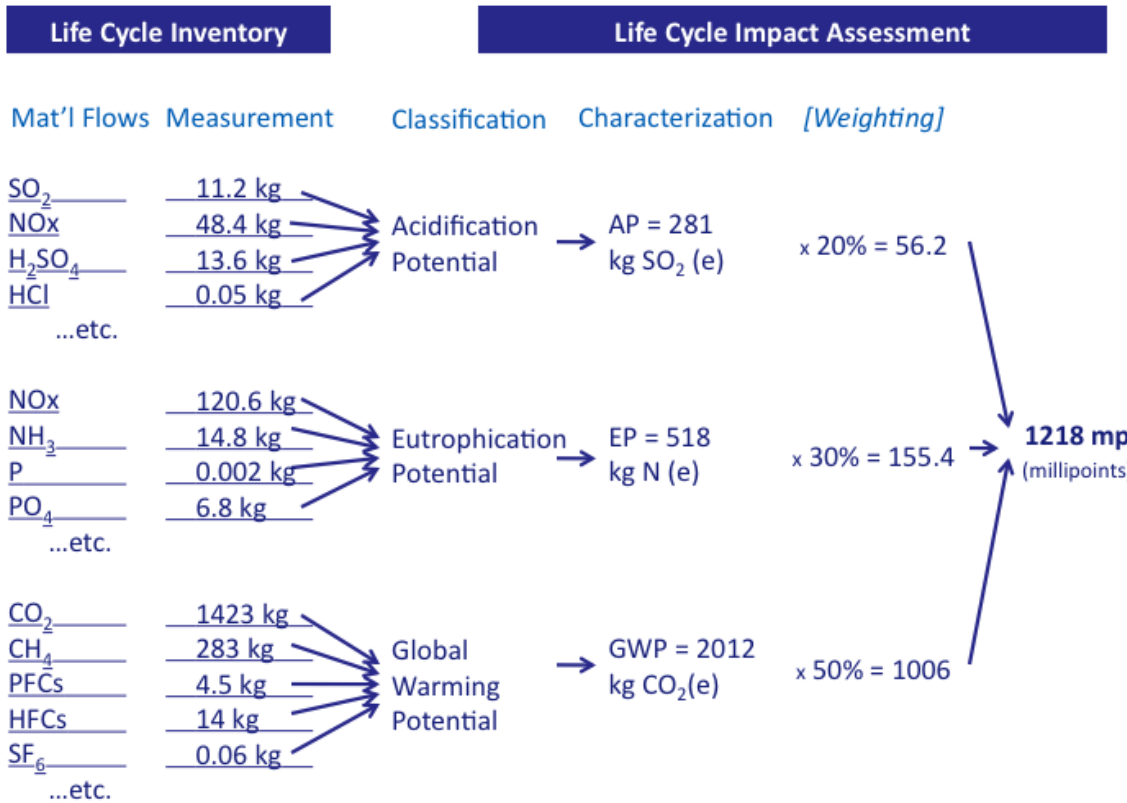

Interpretation

Although listed fourth, life cycle interpretation actually occurs throughout the whole LCA. It involves the ongoing process of clarifying, quantifying, checking, and evaluating the information used by, and resulting from, the life cycle inventory (LCI) and impact assessment (LCIA) phases. The standard covering LCAs, ISO 14044, gives two main objectives:

- Analyze results, reach conclusions, explain limitations, and provide recommendations based on the findings of the preceding phases of the LCA, and to report the results of the life cycle interpretation in a transparent manner.
- Provide a readily understandable, complete, and consistent presentation of the results of an LCA study, in accordance with the goal and scope of the study.

To achieve these objectives, the ISO standard states that interpretation should cover at least three major elements.

- Identification of the significant issues based on the LCI and LCIA. Which life cycle phases or components stand out as major contributors to overall impact? What are the anomalies?
- Evaluation which considers completeness, sensitivity, and consistency checks. Is all the information needed for interpretation present in the LCI and LCIA? How reliable is the information related to any identified significant issues? How much do changes in such factors influence the overall results? Are all of the assumptions, data, characterization

- factors, etc. that were used in the assessment consistent internally and with the overall goal and scope of the LCA?
- Conclusions, recommendations, and reporting. As discussed in later sections of this guide, a great deal of an LCA's value depends on how its results are communicated to people involved in making relevant decisions, whether other designers, engineers, management, marketers, or other parts of the supply chain.

It is very important to note that no matter how carefully assembled, analyzed, assessed, and measured, LCAs are never the “real” answer. They require interpretation, which in turn requires transparency and judgment. The data sources, assumptions, and all other relevant information needs to be transparent to decision makers so that they can understand the full context of the results of the life cycle inventory assessment. Deciding among design options is not as easy as just comparing LCIA numbers, whether single- or multi-factor, weighted or not. LCIA results can be a source of insights, but do not stand alone in guiding product development choices. Engineers will need to take them in the context of the other attributes they are trying to optimize, including cost, manufacturability, performance, and so on. In addition, there are myriad other factors guiding product development decisions not covered by LCAs, including social impacts and acceptance, pricing, political agendas, and regulations.

Appendix C – LCA Tools and Methods

Commonly used LCA Tools

A 2006 survey of 65 LCA practitioners⁴⁵ reported that:

58%* used GaBi (PE International)

31%* used SimaPro (PRé Consultants)

11%* used TEAM (Ecobilan)

Other tools cited:

- BEES (NIST)
- Umberto (ifu Hamburg)
- ECO-IT (PRé Consultants)
- Excel-based spreadsheets
- Math package (e.g. MATLAB, Mathematica)

Impact Assessment Methodologies

Impact assessment methodologies are the systematic calculations that are used to get from an LCI (life cycle inventory) flow, such as carbon dioxide or sulfur dioxide, to the environmental impact that it causes. The results of these calculations typically measure either *midpoint* or *endpoint* effects (endpoint effects are sometimes called *damage effects*). For example, the following chart shows how some midpoint effects map to their respective endpoint effects⁴⁶:

⁴⁵ Cooper, J.S.; Fava, J. (2006), "Life Cycle Assessment Practitioner Survey: Summary of Results", *Journal of Industrial Ecology*

* percentages include overlap due to usage of multiple tools

⁴⁶ "IMPACT 2002+" LCIA methodology / Dr. Olivia Jolliet, Univ. of Michigan:

<http://www.sph.umich.edu/riskcenter/jolliet/impact2002+.htm>

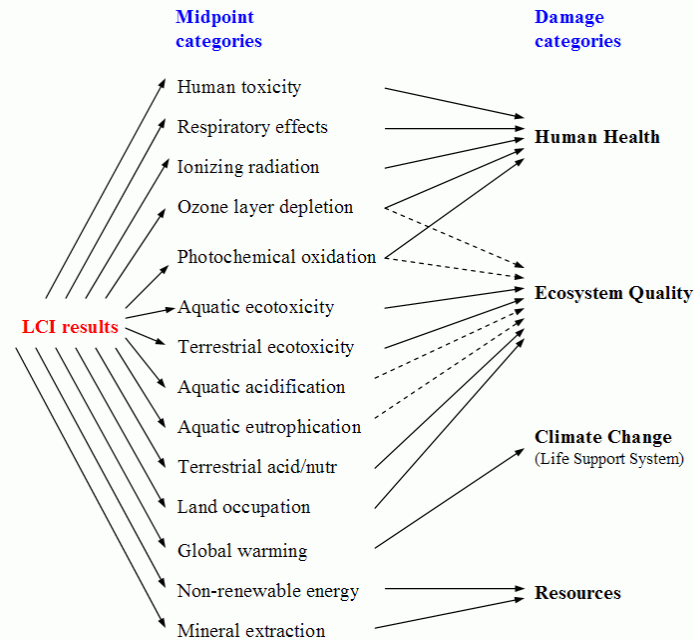

While the endpoint or damage effects are the ones we really care about, these can be difficult to measure directly. For example, how many degrees of global average temperature increase are caused by one firm's activities? It's very hard to measure such a fractional effect, so we tend to measure the *midpoint* effect of greenhouse gas emissions, which lead to global average temperature increases. Most impact assessment methodologies use midpoint measurements.

There are several impact assessment methodologies that are commonly used in the LCIA steps of an LCA, which include classification and characterization, and optionally normalization and/or weighting. Some of these impact assessment methodologies are described below.⁴⁷

CML ("CML 1996", "CML 2001")

The CML methodology, developed by the Institute of Environmental Sciences at the University of Leiden in the Netherlands, is the most widely-used and often considered the most complete methodology. It uses primarily European data to derive its impact factors. It groups the LCI results into midpoint categories, according to themes; these themes are common mechanisms (e.g. climate change) or groupings (e.g. ecotoxicity). There is a "CML 1996" and a "CML 2001" method. Its results can be viewed as a spreadsheet that presents characterization factors for more than 1700 flows (2001).

The CML impact assessment methodology is the one we have chosen to calculate the results for SolidWorks Sustainability.

For more information, see:

⁴⁷ Information for this section was taken from "Life Cycle Impact Assessment (LCIA) Methods" from the GaBi LCIA documentation, which can be found at http://documentation.gabi-software.com/1_LCIA.html.

- Institute of Environmental Sciences, Leiden University, The Netherlands: Handbook on impact categories "CML 1996",
<http://www.leidenuniv.nl/cml/ssp/projects/lca2/index.html>
- Institute of Environmental Sciences, Leiden University, The Netherlands: Handbook on impact categories "CML 2001",
<http://www.leidenuniv.nl/cml/ssp/projects/lca2/index.html>
- Institute of Environmental Sciences, Leiden University, The Netherlands: "Life Cycle Assessment, An operational guide to the ISO standards, Volume 1, 2 and 3",
<http://www.leidenuniv.nl/interfac/cml/ssp/projects/lca2/lca2>

Eco-Indicator (“95”, “99”)

Like the CML methodology, the Eco-Indicator method includes classification (“categories of effect”) and characterization steps, grouping the LCI results into midpoint categories.

These impact data are then weighted according to a social evaluation process. For example, the Eco-Indicator 95 method specifies that 1 death per 1,000,000 inhabitants is equal to 5% surface loss of an intact ecosystem. This weighting is performed in order to compare different types of environmental effects directly together; the results can then be presented as a single score, the so-called Eco-Indicator score.

Impact factors for Eco-Indicator 99 are collected and published in a spreadsheet by the Institute of Environmental Sciences, Leiden University, The Netherlands, and are furnished by PRé Consultants, makers of the Sima Pro LCA software package.

The data are then *normalized*, or divided by a common reference value, to facilitate communication. In the case of Eco-Indicator 95, the data are normalized after classification using the annual European contributions per inhabitant for the impact category. In Eco-Indicator 99, the data are normalized based on published information furnished by PRé Consultants⁴⁸.

Because Eco-Indicator is a single-score LCA methodology, we do not include it as an option in SolidWorks Sustainability.

TRACI

The “Tool for the Reduction and Assessment of Chemical and Other Environmental Impacts”, or TRACI, is an impact assessment methodology developed by the US Environmental Protection Agency. As with the other impact assessment methodologies, TRACI is primarily a midpoint approach. It differs from the CML methodology in that the data comes primarily from North American sources. However, the TRACI methodology is not as comprehensive or complete as the CML method. For this reason, we have programmed SolidWorks Sustainability to perform the calculations using TRACI as well as CML, but haven’t enabled the TRACI results as an option.

The following is a handy chart that demonstrates the difference between single-score and multiple-indicator impact assessment methodologies.

⁴⁸ More information can be found at <http://www.pre.nl/eco-indicator99/>.

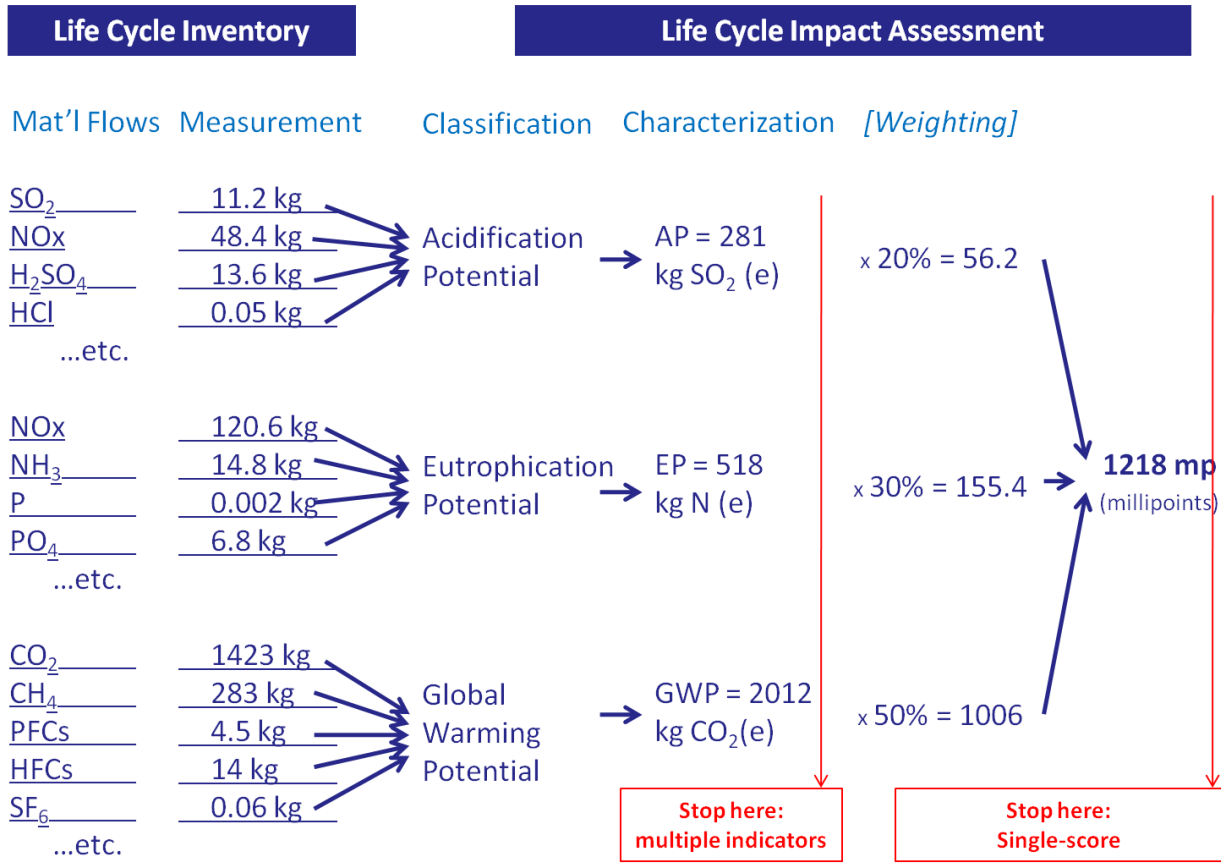

For example, Eco-Indicator 95 looks like this:

