

# HP DeskJet 840C Series (USB) Printer User's Guide for Macintosh

## English



Expanding Possibilities



## HP Customer Care

Thank you for buying an HP DeskJet printer. Because HP wants owning your printer to be a trouble-free experience, we back your purchase with **HP Customer Care**—award-winning service and support that includes:



### HP Customer Care Online

Click your way to a quick solution! **HP Customer Care Online** is a great place to start for answers to questions about your HP DeskJet printer — 24 hours a day, seven days a week.

If you have a modem connected to your computer and subscribe to an online service, or have direct access to the Internet, you can obtain a wide variety of information about your printer at the following web sites:

English:	<a href="http://www.hp.com/support/home_products">http://www.hp.com/support/home_products</a>
French:	<a href="http://www.hp.com/cposupport/fr/">http://www.hp.com/cposupport/fr/</a>
German:	<a href="http://www.hp.com/cposupport/de">http://www.hp.com/cposupport/de</a>
Japanese:	<a href="http://www.jpn.hp.com/CPO_TC/eschome.htm">http://www.jpn.hp.com/CPO_TC/eschome.htm</a>
Portuguese:	<a href="http://www.hp.com/cposupport/pt">http://www.hp.com/cposupport/pt</a>
Spanish:	<a href="http://www.hp.com/cposupport/es/">http://www.hp.com/cposupport/es/</a>

From **HP Customer Care Online** you can link to **HP Customer Care User Forums** and **HP Customer Care Email**.



### HP Customer Care User Forums

Go online, anytime, and you will also find helpful user forums—a great source of ideas and suggestions for using your HP DeskJet printer. You can access the user forums directly from [http://www.hp.com/support/home\\_products](http://www.hp.com/support/home_products).



### HP Customer Care by Phone

Call us direct and connect with a service technician who specializes in your product and who can typically answer your questions in one phone call. See page 43 in this *User's Guide* for phone numbers.

## Acknowledgments

Apple, the Apple logo, AppleTalk, ColorSync, the ColorSync logo, Finder, Mac, Macintosh, MacOS, PowerBook, Power Macintosh, and QuickDraw are trademarks of Apple Computer, Inc., registered in the U.S. and other countries.

## Notice

The information contained in this document is subject to change without notice.

Hewlett-Packard Company makes no warranty of any kind with regard to this material, including, but not limited to, the implied warranties of merchantability and fitness for a particular purpose.

Hewlett-Packard shall not be liable for any errors or for incidental or consequential damages in connection with the furnishing, performance, or use of this material.

All rights reserved. Reproduction, adaptation, or translation of this manual is prohibited without prior written permission of Hewlett-Packard Company, except as allowed under the copyright laws.

No part of this document may be photocopied, reproduced, or translated to another language without the prior written consent of Hewlett-Packard Company.

Edition 1, September 1999

© Copyright Hewlett-Packard Company and Apple Computer, Inc. 1999

Portions © Copyright 1989-1999 Palomar Software, Inc. HP DeskJet 800C Series Printers includes printer driver technology licensed from Palomar Software, Inc., [www.palomar.com](http://www.palomar.com).



# Table of Contents

Chapter 1	Using Your Printer	
	Buttons and Lights .....	1
	Paper Trays .....	2
	Basic Printer Maintenance .....	3
Chapter 2	Using Your Printer Software	
	Choosing Your Printer .....	4
	Other Ways to Select a Default Printer .....	4
	Desktop Printing .....	5
	Checking Printer Status .....	5
	Page Setup - Controlling Page Layout .....	6
	Print Dialog Box .....	7
	Printing on Different Types of Paper and Media .....	13
	HP DeskJet Utility Window .....	24
Chapter 3	Using and Caring for Your Print Cartridges	
	Print Cartridge Status .....	26
	Replacing Print Cartridges .....	26
	Storing Print Cartridges .....	28
	Cleaning Print Cartridges .....	29
	Damage Resulting from Refilling the Print Cartridges .....	32
Chapter 4	Getting Help When Things Go Wrong	
	Troubleshooting Tips .....	33
	HP Customer Care .....	42
Chapter 5	Supplies and Accessories	
	Printer Supplies .....	45
	Printer Quick Start Posters and User's Guide for Macintosh .....	45
	Paper and Other Media .....	46
	Ordering Information .....	47
Appendix A	Setup Instructions .....	49
Appendix B	Specifications .....	52
Appendix C	Legal Information .....	55



## Table of Contents

Regulatory Notices .....	55
Limited Warranty Statement .....	56
HP Year 2000 Warranty .....	56
Index .....	57



# Introduction

## Thank You For Buying an HP DeskJet Printer!

Here's what comes in the box. If something is missing, talk to your HP dealer or call HP Customer Care. (See "HP Customer Care by Phone" on page 43 for the appropriate telephone number.)

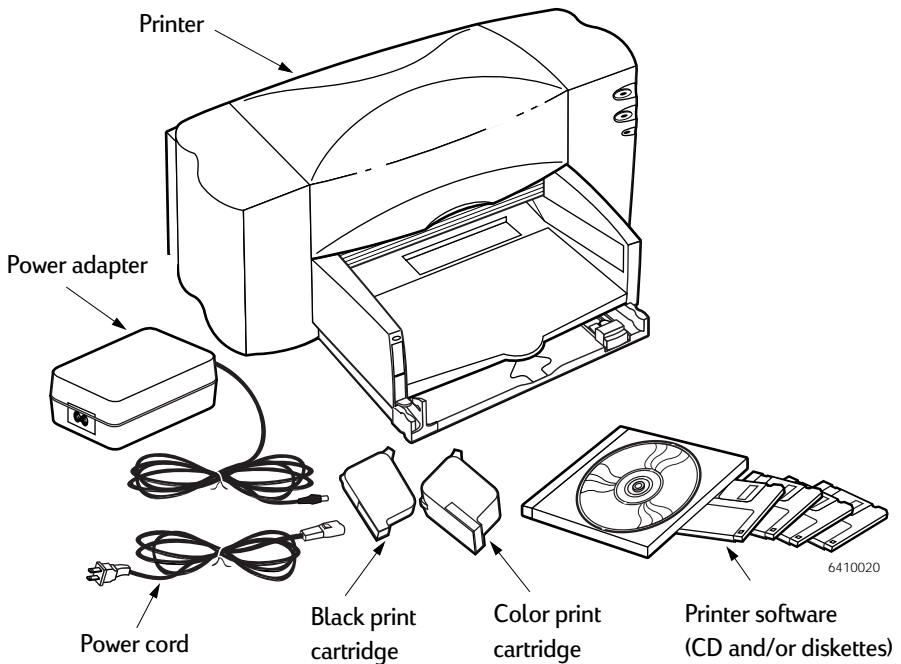

**Note:** You will need to buy a USB-to-USB printer cable to connect your HP DeskJet printer to your computer. See page 45 for ordering information.



## Introduction

### Special Features of Your HP DeskJet Printer

Your new HP DeskJet printer is equipped with special features:

- Stunning photo quality through HP's Color Layering Technology
- Laser-quality black text
- Excellent print quality on plain paper
- Uncompromising performance with print speeds of up to 8 pages per minute for black text and 5 pages per minute for text with color graphics with the HP DeskJet 840C Series printers
- Efficient, fast photo image printing
- Large capacity paper tray that holds up to 100 sheets

### Finding More Information

This *User's Guide* shows you how to operate your printer. For more information:

- Use the *Quick Start Poster* for installation.
- Turn on balloon help in the **Help** menu. Move your cursor over any print setting to view an explanation.
- Visit the HP web site at [http://www.hp.com/support/home\\_products](http://www.hp.com/support/home_products) for the latest product information, troubleshooting, and printer software updates.

# 1 Using Your Printer

## Buttons and Lights

The buttons on the front of your HP DeskJet printer let you turn the printer on and off, or to resume printing. The lights give you visual cues about the state of your printer. The buttons and lights from top to bottom are:

 **Power Button and Light** – Use the Power Button to turn the printer on and off. The green light on the Power Button flashes when printing is in progress.

 **Resume Button and Light** – Whenever the light on the Resume Button flashes, press the Resume Button to continue printing.

 **Print Cartridge Status Light** – When lit, this light indicates that you need to check the status of your print cartridges. “Print Cartridge Status” on page 26 for more information.

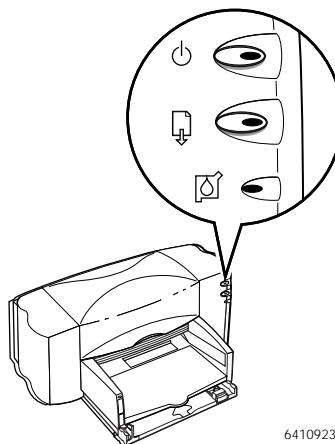

6410923

### Warning

Only use the Power Button on the front of the printer to turn the printer on and off. Using a power strip, surge protector, or a wall-mounted switch to turn the printer on and off may cause premature printer failure.



## Paper Trays

### IN Tray

You place paper and other media types for printing in the IN tray. Pull out this tray for easy loading. Once you insert the media you want to use, slide the paper guides so they rest snugly against the media. Be sure to slide all media as far as it will go into the IN tray.

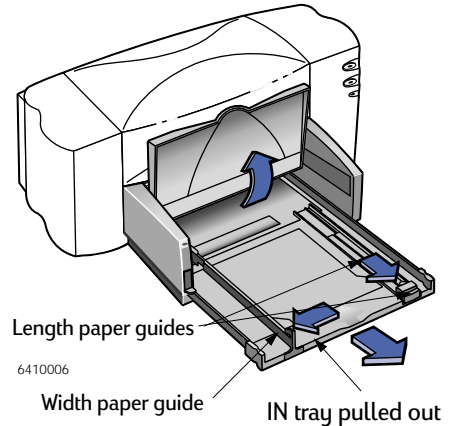

### OUT Tray

The printer sends its completed pages to the OUT tray. The OUT tray has two different positions.

Up – For ease of loading media in the IN tray.

Down – For printing, flip the OUT tray down. Be sure to slide both paper adjusters to fit snugly against the paper's edges. Make sure the paper lies flat in the tray and that the paper fits under the tab of the length paper guide.

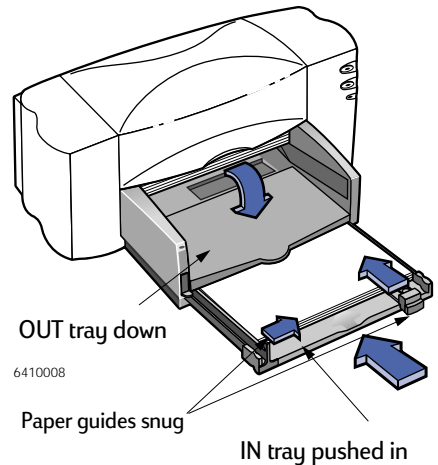

## Basic Printer Maintenance

Because the printer ejects ink onto the paper in a fine mist, ink smudges will eventually appear on the printer case. To remove smudges, stains, and/or dried ink from the exterior of the printer, use a soft cloth moistened with water.

When cleaning your printer, keep these tips in mind:

- **Do not** clean the interior of the printer. Keep all fluids away from the interior.
- **Do not** use household cleaners or detergent. In the event that a household cleaner or detergent is used on the printer, wipe the printer's exterior surfaces with a soft cloth moistened with water.
- **Do not** lubricate the rod on which the print cartridge cradle moves. Noise is normal when the cradles move back and forth.

For information on cleaning print cartridges and the print cartridge cradle, see "Cleaning Print Cartridges" on page 29.

# 2 Using Your Printer Software

**Note:** Before you can use your printer, you must have installed the printer and printer software as described on the *Quick Start Poster*.

## Choosing Your Printer

If you haven't already selected your **HP DeskJet** as the default printer in the **Chooser**, you should do so now. To select your printer using a USB connection:

- 1 Make sure the computer and printer are turned on, and your printer is connected to your computer with a USB cable.
- 2 From the **Apple** menu, select **Chooser**.
- 3 In the left side of the Chooser window, click the **DeskJet 800 Series (USB)** icon.
- 4 In the right side of the Chooser window, click **DeskJet 840C**.
- 5 Close the **Chooser**.

## Other Ways to Select a Default Printer

Besides using the Chooser, you can also select a default printer in the following ways:

- Select the desired printer by clicking on the menu bar **printer icon** at the top of the screen, and choosing **DeskJet 840C**.
- If your control strip is on, then select the desired printer by clicking the **printer icon** in the control strip, and choosing **DeskJet 840C**.
- Drag the document you want to print to the desktop icon of the printer you want to use.
- Click the icon of the **HP DeskJet printer** you want to use, and choose **Set Default Printer** from the **Printing** menu.

The Print command will send your documents to this printer until you select a new default printer. If you switch printers, check your document before you print it to see whether the formatting or pagination changed.

## Desktop Printing

Desktop printing is useful when you have a number of documents to print at once, or when you have a document that is already formatted for printing on a particular printer. There are two methods to print documents from the desktop. To perform desktop printing, either:







- Drag the icons of the documents you want to print to the desktop icon of the printer you want to use.

*OR*

- Select the icons of the documents you want to print, then choose **Print** from the **File** menu. When the **Print** dialog box appears, select your print options, then click the **Print** button.

## Checking Printer Status

You can tell the status of a printer by looking at its desktop icon:

Icon	Description	Icon	Description
 DESKJET 840C	Idle printer (default)	 DESKJET 840C	Printing stopped on default printer
 DESKJET 840C	Idle printer (not default)	 DESKJET 840C	Error on default printer
 DESKJET 840C	Printing on default printer	 DESKJET 840C	Printer not available or connected

## Page Setup - Controlling Page Layout

You control settings such as paper size, scaling, page orientation, and watermarks from the **HP DeskJet 800 Series Page Setup** dialog box. To get to this dialog box:

- 1 Open the software program used to create your document.
- 2 From the **File** menu, select **Page Setup**.

### Paper Size, Scaling, and Page Orientation

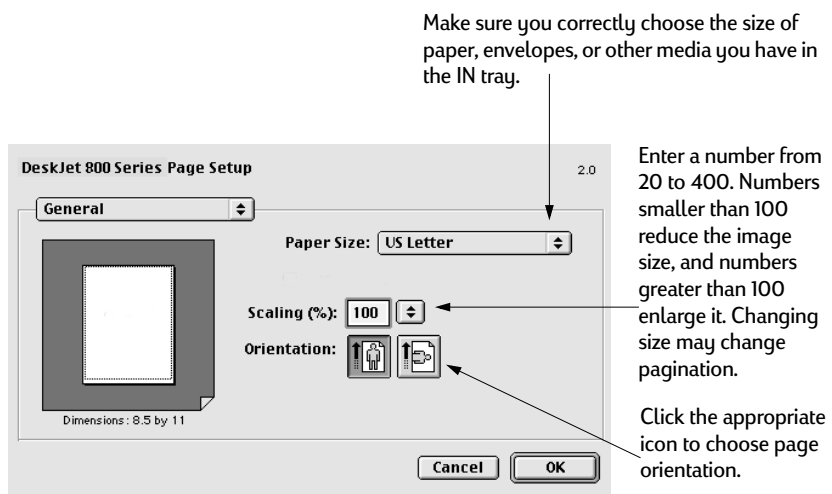

## Print Dialog Box

You control settings such as number of copies, all or specific pages to print, paper type, print quality, page layout, color, and background printing from the **HP DeskJet 800 Series Print** dialog box. To get to this dialog box, select **Print** from your software program's **File** menu.

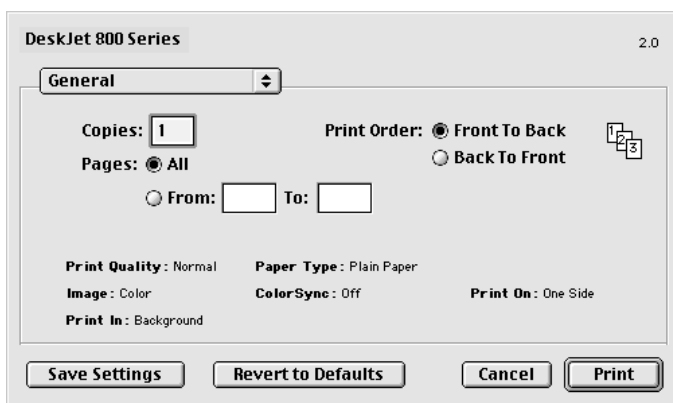

### Buttons

There are four buttons at the bottom of every Print dialog box:

- **Save Settings** saves any print settings you select for this and future documents
- **Revert to Defaults** returns your print settings to the original HP-defined settings
- **Cancel** cancels settings you have entered and closes the Print dialog box
- **Print** starts printing

## General

**General** is the default panel selected in the Print dialog box menu. This panel lets you select the number of copies you want to print, whether you want to print the entire document or select pages, and whether you want to print from the front of your document or begin printing from the end forward.

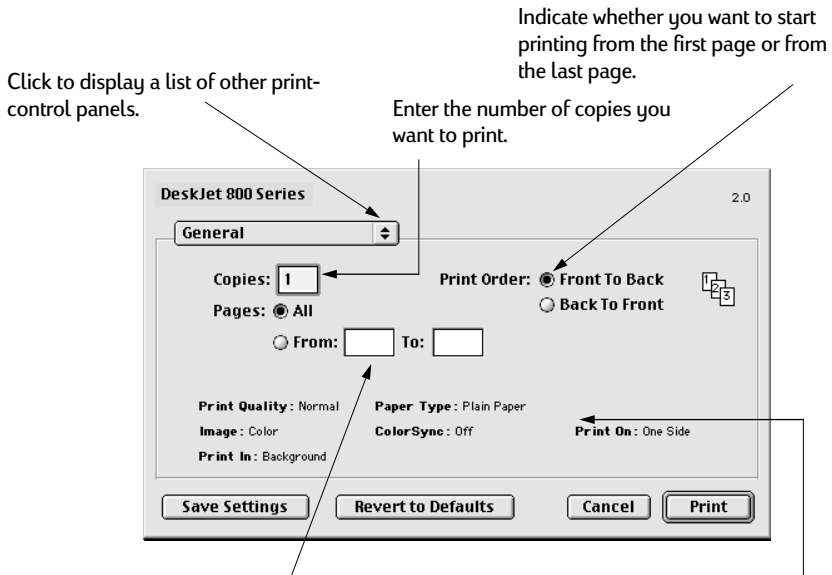

If you don't want to print the entire document, enter the beginning and ending page numbers you want to print.

This area displays options set in other Print panels.

You may also choose the following options from the **General** menu:

- **Paper Type/Quality** (see “Paper Type/Quality” on page 9)
- **Layout** (see “Layout” on page 9)
- **Color** (see “Color” on page 10)
- **Background Printing** (see “Background Printing” on page 11)
- **Ink Controls** allows you to adjust the ink volume and dry time

## Paper Type/Quality

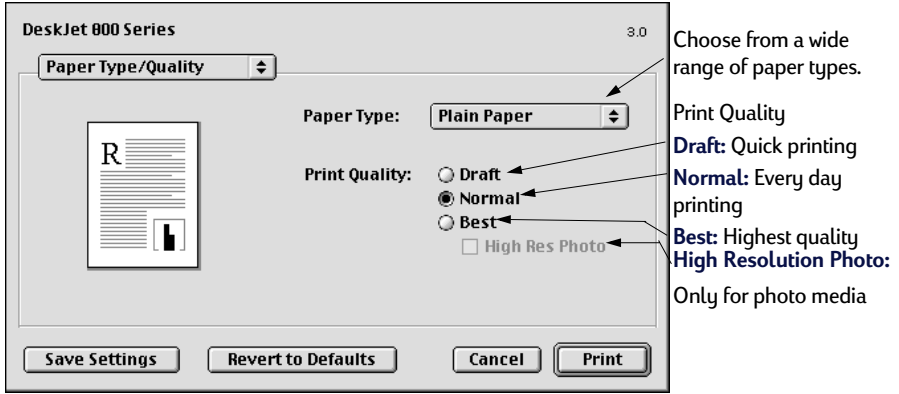

## Layout

This dialog box allows you to specify the number of pages printed on each sheet of paper, or to print a poster by specifying the number of pages printed across and down. You also set **Two-Sided Printing** options from this dialog box.

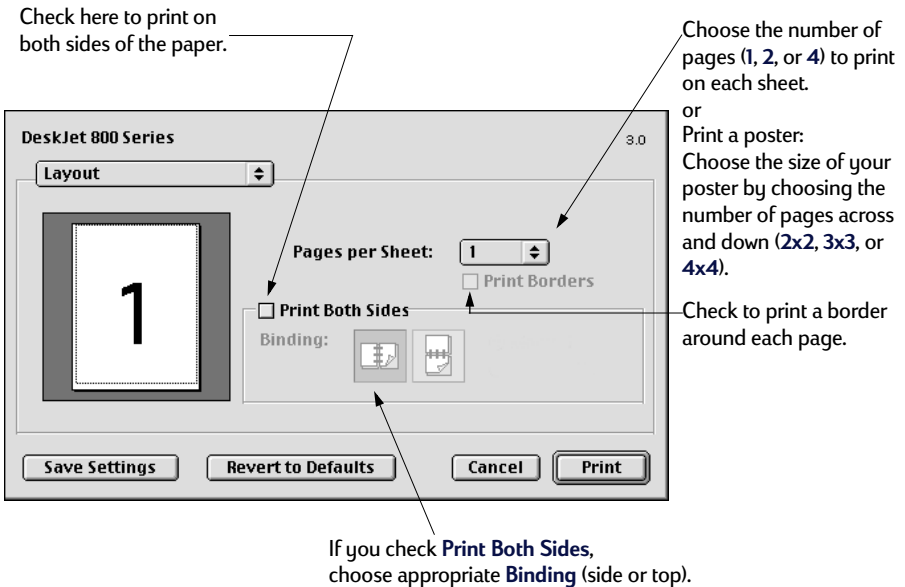



## Color

Your HP DeskJet 800C Series Printer uses HP's Color Matching technology to intelligently analyze each element on a page—text, graphics, and photographs—and provide the best color output.

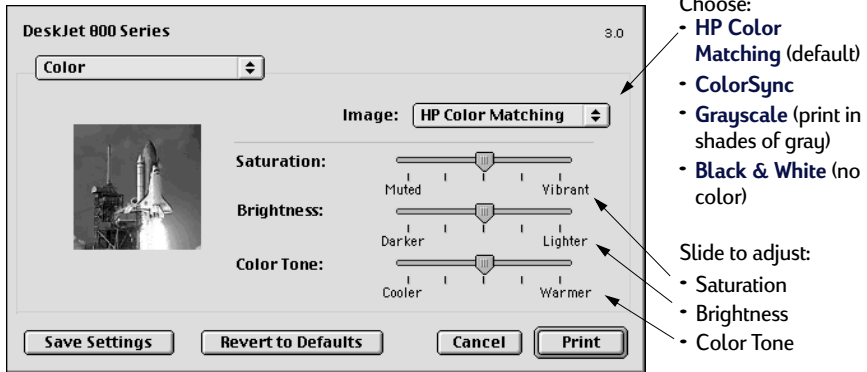

**HP Color Matching** is the default **Image** setting on the Color panel. While you can adjust saturation, brightness, and color tone with the sliders that appear when you choose this option, the center position of the sliders is optimized for most printing uses and types of media.

The **ColorSync** setting can be used for color matching with other components using the ColorSync matching system.

**Grayscale** prints in shades of gray. With this setting, you also have the option to optimize printing for fax and photocopy.

**Black & White** prints only in black and white (no color, no gray).

## Background Printing

Choose **Background** if you want to continue working while printing takes place. If you choose **Foreground** printing, printing will be faster, but you won't be able to work on other tasks until the printing is complete.

Choose:

- **Background** to continue working while printing
- **Foreground** for faster printing

Click the button that matches the desired timing for your print job

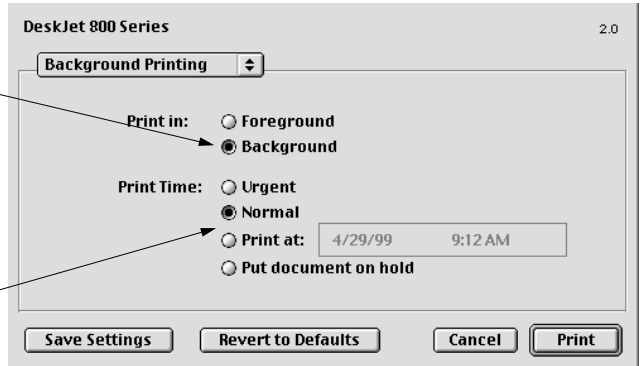

## Using Your Printer Software

The following table describes additional features available when using background printing. To access these features from the desktop, double-click the **HP DeskJet 840C Series** printer icon.

Background Printing Options	Instructions
Delete a print job	<ul style="list-style-type: none"> <li>• Select the <b>job title</b> or icon, then click the <b>Trash</b> icon.</li> <li>or</li> <li>• Drag the document's icon to the Trash on your desktop.</li> </ul> <p>These methods delete only the print job, not the document itself.</p>
Hold/pause a print job	<ul style="list-style-type: none"> <li>• Select the <b>job title</b> or icon, then click the <b>Pause</b> button. The print request will pause until you select its title again and click the <b>Resume</b> Button.</li> <li>or</li> <li>• Drag the document icon to the <b>Waiting to Print</b> list of documents.</li> </ul>
Mark a print request "Urgent"	<ul style="list-style-type: none"> <li>• Select the <b>job title</b> or icon, then click the <b>small clock</b>.</li> <li>• In the dialog box that appears, click <b>Urgent</b>. This moves the print request to the top of your print list.</li> </ul>
Print at a specific time	<ul style="list-style-type: none"> <li>• Select the <b>job title</b> or icon, then click the <b>small clock</b>.</li> <li>• In the dialog box that appears, click <b>At Time</b>, then set the <b>time</b> and <b>date</b> to print.</li> </ul>
Sort/change the order of print jobs	<ul style="list-style-type: none"> <li>• From the <b>View</b> menu, choose the <b>title of the column</b> by which you want to sort or choose.</li> <li>• To see and change the print order, sort by <b>Print Time</b>.</li> <li>• Drag and drop the print job <b>title</b> to the desired place in the list.</li> </ul>
Stop and restart printing	<ul style="list-style-type: none"> <li>• Choose <b>Stop Print Queue</b> from the <b>Printing</b> menu.</li> <li>• To resume printing, choose <b>Start Print Queue</b>.</li> </ul> <p>This is a good way to save print requests when using a portable computer while away from your printer.</p>
Change printers	<p>To move a print job from one printer to another printer of the same type:</p> <ul style="list-style-type: none"> <li>• Drag the <b>icon</b> for the print request to the icon of the <b>desired printer</b>.</li> </ul> <p>If you're not sure whether the two printers are of the same type, try moving the print request anyway; the printer software won't let you move a print request to an incompatible printer.</p>

## Printing on Different Types of Paper and Media

The HP DeskJet 800C Series printer is designed to encompass so many different types of print media that you're practically set up as a small print shop. This chapter explains how to use the different printing materials available to you.

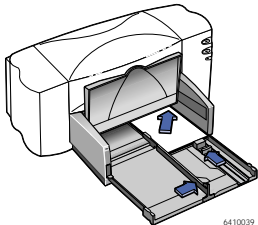

### Printing Photographs

I want to print...	I should...
<p><b>Photo Paper</b></p> 	<ol style="list-style-type: none"> <li>1 Remove all paper from the IN tray.</li> <li>2 Raise the OUT tray to the up position.</li> <li>3 Insert the photo paper into the IN Tray, glossy side down.</li> <li>4 Lower the OUT tray.</li> <li>5 Slide the paper guides snugly against the sheets.</li> <li>6 Push in the IN tray.</li> <li>7 Choose the print settings that match the type and size of the photo paper.</li> <li>8 Print the photos.</li> </ol>
HP print settings to choose	Guidelines to remember
<p><b>Page Setup</b></p> <ul style="list-style-type: none"> <li>- <i>Paper Size</i>: Choose appropriate paper size</li> <li>- <i>Orientation</i>: Choose appropriate orientation</li> </ul> <p><b>Paper Type/Quality</b></p> <ul style="list-style-type: none"> <li>- <i>Paper Type</i>: Choose photo paper type</li> <li>- <i>Print Quality</i>: Choose <b>Best</b></li> </ul> <p><b>Layout</b></p> <ul style="list-style-type: none"> <li>- <i>Pages per Sheet</i>: 1</li> <li>- <i>Print Both Sides</i>: Unchecked</li> </ul>	<ul style="list-style-type: none"> <li>• For best results, use HP Premium Photo Paper, Glossy, or HP Premium Photo Paper, Matte or Glossy.</li> <li>• The photo needs to be in electronic (digital) form, before you can print it. Take a digital picture, scan a photo, or have your local camera shop provide an electronic file of your photo.</li> <li>• Remember to lower the OUT tray once the photo paper is loaded.</li> <li>• After selecting your paper type, choose the appropriate paper size from the pull-down menu.</li> </ul>

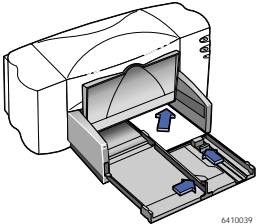

## Printing Greeting Cards and Hagaki

I want to print...	I should...
	<ol style="list-style-type: none"> <li>1 Slide out both of the paper guides, remove all paper from the IN tray, slide out the IN tray, and flip up the OUT tray.</li> <li>2 Insert up to 30 cards into the IN tray as far as they will go.</li> <li>3 Slide the paper guides snugly against the edges of the cards.</li> <li>4 Make sure the IN tray is pushed in and flip down the OUT tray.</li> <li>5 Choose the print settings that match the type and size of the cards.</li> <li>6 Print the cards.</li> </ol>
HP print settings to choose	Guidelines to remember
<p><b>Page Setup</b></p> <ul style="list-style-type: none"> <li>- <i>Paper Size</i>: Choose appropriate card size</li> <li>- <i>Orientation</i>: Choose <b>Portrait</b> icon</li> </ul> <p><b>Paper Type/Quality</b></p> <ul style="list-style-type: none"> <li>- <i>Paper Type</i>: Choose greeting card type or <b>Plain Paper</b> or <b>Inkjet Paper</b> for Hagaki</li> <li>- <i>Print Quality</i>: Choose <b>Normal</b></li> </ul> <p><b>Layout</b></p> <ul style="list-style-type: none"> <li>- <i>Pages per Sheet</i>: 1</li> <li>- <i>Print Both Sides</i>: Unchecked</li> </ul>	<ul style="list-style-type: none"> <li>• For best results use HP Greeting Card Paper.</li> <li>• For Hagaki, use Plain Paper or Inkjet Paper.</li> <li>• Use <b>Plain Paper</b> setting to print Hagaki's address side.</li> <li>• If you have pre-folded greeting cards, unfold the cards, then load the cards into the IN tray.</li> <li>• Align the card edges before inserting the cards.</li> <li>• For ease of loading small cards, pull out the IN tray and raise the OUT tray. After you have inserted the cards, push the IN tray in and lower the OUT tray.</li> </ul>

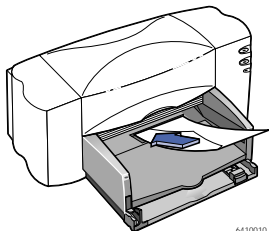

## Printing Envelopes

I want to print...	I should...
<p><b>Single envelope</b></p>  <p style="text-align: right; font-size: small;">6410010</p>	<ol style="list-style-type: none"> <li>1 Slide the envelope, with its flap side on the left and flap facing up, into the OUT tray's single envelope slot. Push the envelope in until it stops.</li> <li>2 Choose the print settings that match the type and size of the envelope.</li> <li>3 Print the envelope.</li> </ol>
HP print settings to choose	Guidelines to remember
<p><b>Page Setup</b></p> <ul style="list-style-type: none"> <li>- <i>Paper Size</i>: Choose appropriate envelope size</li> <li>- <i>Orientation</i>: Choose <b>Portrait</b> icon</li> </ul> <p><b>Paper Type/Quality</b></p> <ul style="list-style-type: none"> <li>- <i>Paper Type</i>: Choose <b>Plain Paper</b></li> <li>- <i>Print Quality</i>: Choose <b>Normal</b></li> </ul> <p><b>Layout</b></p> <ul style="list-style-type: none"> <li>- <i>Pages per Sheet</i>: 1</li> <li>- <i>Print Both Sides</i>: Unchecked</li> </ul>	<ul style="list-style-type: none"> <li>• Make sure paper is loaded in the IN tray.</li> <li>• Make sure the OUT tray is in the down position.</li> <li>• Avoid envelopes that have clasps or windows.</li> <li>• Avoid envelopes that are shiny or embossed, envelopes with thick, irregular, or curled edges, or envelopes that are wrinkled, torn, or otherwise damaged.</li> <li>• If your software program includes an envelope-printing feature, follow those instructions instead of the procedure here.</li> </ul>

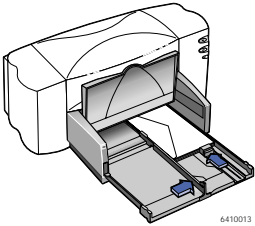
I want to print...	I should...
<p><b>Stack of envelopes</b></p> 	<ol style="list-style-type: none"> <li>1 Slide out both of the paper guides, and remove all paper from the IN tray.</li> <li>2 Slide up to 15 envelopes, with their flap side on the left and flap facing up, into the IN tray as far as they will go.</li> <li>3 Slide the paper guides snugly against the edges of the envelopes.</li> <li>4 Make sure the IN tray is pushed in.</li> <li>5 Choose the print settings that match the type and size of the envelopes.</li> <li>6 Print the envelopes.</li> </ol>
HP print settings to choose	Guidelines to remember
<p><b>Page Setup</b></p> <ul style="list-style-type: none"> <li>- <i>Paper Size</i>: Choose appropriate envelope size</li> <li>- <i>Orientation</i>: Choose <b>Portrait</b> icon</li> </ul> <p><b>Paper Type/Quality</b></p> <ul style="list-style-type: none"> <li>- <i>Paper Type</i>: Choose <b>Plain Paper</b></li> <li>- <i>Print Quality</i>: Choose <b>Normal</b></li> </ul> <p><b>Layout</b></p> <ul style="list-style-type: none"> <li>- <i>Pages per Sheet</i>: 1</li> <li>- <i>Print Both Sides</i>: Unchecked</li> </ul>	<ul style="list-style-type: none"> <li>• Never load more than 15 envelopes at one time.</li> <li>• Align the envelope edges before inserting them.</li> <li>• Avoid envelopes that have clasps or windows.</li> <li>• Avoid envelopes that are shiny or embossed, envelopes with thick, irregular, or curled edges, or envelopes that are wrinkled, torn, or otherwise damaged.</li> <li>• If your software program includes an envelope-printing feature, follow those instructions instead of the procedure here.</li> </ul>

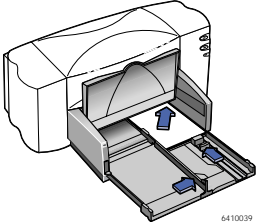

## Printing Cards

I want to print...	I should...
<p><b>Cards (index, business, and other small media)</b></p>  <p style="text-align: right; font-size: small;">6410039</p>	<ol style="list-style-type: none"> <li>1 Pull out the IN tray.</li> <li>2 Slide out both of the paper guides, and remove all paper from the IN tray.</li> <li>3 Insert up to 30 cards into the IN tray as far as they will go.</li> <li>4 Slide the paper guides snugly against the edges of the cards.</li> <li>5 Make sure the IN tray is pushed in.</li> <li>6 Choose the print settings that match the type and size of the cards.</li> <li>7 Print the cards.</li> </ol>
HP print settings to choose	Guidelines to remember
<p><b>Page Setup</b></p> <ul style="list-style-type: none"> <li>- <i>Paper Size</i>: Choose appropriate card size</li> <li>- <i>Orientation</i>: Choose <b>Portrait</b> icon</li> </ul> <p><b>Paper Type/Quality</b></p> <ul style="list-style-type: none"> <li>- <i>Paper Type</i>: Choose <b>Plain Paper</b></li> <li>- <i>Print Quality</i>: Choose <b>Normal</b></li> </ul> <p><b>Layout</b></p> <ul style="list-style-type: none"> <li>- <i>Pages per Sheet</i>: 1</li> <li>- <i>Print Both Sides</i>: Unchecked</li> </ul>	<ul style="list-style-type: none"> <li>• Align the edges of the media before inserting.</li> <li>• For ease of loading small cards, pull out the IN tray and raise the OUT tray. After you have inserted the cards, lower the OUT tray.</li> </ul>



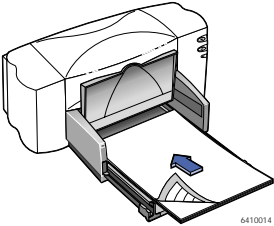

## Printing Labels

I want to print...	I should...
	<ol style="list-style-type: none"> <li>1 Slide out both of the paper guides, and remove all paper from the IN tray.</li> <li>2 Fan the edges of the label sheets to separate them, then align the label edges. Insert up to 20 label sheets (label side down).</li> <li>3 Slide the paper guides snugly against the sheets.</li> <li>4 Make sure the IN tray is pushed in.</li> <li>5 Choose the print settings that match the type and size of labels.</li> <li>6 Print the labels.</li> </ol>
HP print settings to choose	Guidelines to remember
<p><b>Page Setup</b></p> <ul style="list-style-type: none"> <li>- <i>Paper Size:</i> Choose <b>A4</b> or <b>Letter (8.5x11 in.)</b></li> <li>- <i>Orientation:</i> Choose appropriate orientation</li> </ul> <p><b>Paper Type/Quality</b></p> <ul style="list-style-type: none"> <li>- <i>Paper Type:</i> Choose <b>Plain Paper</b></li> <li>- <i>Print Quality:</i> Choose <b>Normal</b></li> </ul> <p><b>Layout</b></p> <ul style="list-style-type: none"> <li>- <i>Pages per Sheet:</i> 1</li> <li>- <i>Print Both Sides:</i> Unchecked</li> </ul>	<ul style="list-style-type: none"> <li>• Use only paper labels that are designed specifically for use with inkjet printers.</li> <li>• Never load more than 20 sheets at one time.</li> <li>• Use only full sheets of labels.</li> <li>• Make sure the sheets are not sticky, wrinkled, or pulling away from their protective backing.</li> <li>• <b>Do not</b> use plastic or clear labels. The ink will not dry when used with plastic or clear labels.</li> </ul>

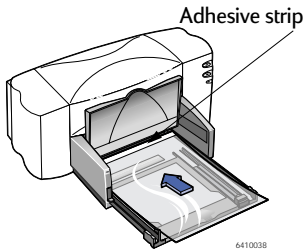

## Printing Transparencies

I want to print...	I should...
	<ol style="list-style-type: none"> <li>1 Slide out both of the paper guides, and remove all paper from the IN tray.</li> <li>2 Fan the edges of the transparency sheets to separate them, then align the edges.</li> <li>3 Insert a stack of up to 25 transparency sheets, rough side down and the adhesive strip toward the printer.</li> <li>4 Slide the paper guides snugly against the transparencies.</li> <li>5 Make sure the IN tray is pushed in.</li> <li>6 Choose the print settings that match the type and size of the transparencies.</li> <li>7 Print the transparencies.</li> <li>8 The printer waits for transparencies to dry before releasing them automatically. Press the <b>Resume Button</b> to continue printing.</li> </ol>
HP print settings to choose	Guidelines to remember
<p><b>Page Setup</b></p> <ul style="list-style-type: none"> <li>- <i>Paper Size</i>: Choose appropriate size</li> <li>- <i>Orientation</i>: Choose appropriate orientation</li> </ul> <p><b>Paper Type/Quality</b></p> <ul style="list-style-type: none"> <li>- <i>Paper Type</i>: Choose transparency type</li> <li>- <i>Print Quality</i>: Choose <b>Normal</b> or <b>Best</b></li> </ul> <p><b>Layout</b></p> <ul style="list-style-type: none"> <li>- <i>Pages per Sheet</i>: 1</li> <li>- <i>Print Both Sides</i>: Unchecked</li> </ul>	<ul style="list-style-type: none"> <li>• For best results, use HP Premium Inkjet Transparency Film or HP Premium Inkjet Rapid-dry Transparencies. The film coating on HP Premium Inkjet Rapid-dry Transparencies is especially developed to work with HP inks, giving you crisp images and text and the fastest drying times. In addition, they won't jam your printer.</li> </ul>

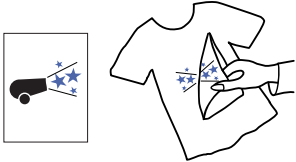

## Printing Iron-on Transfers

I want to print...	I should...
	<ol style="list-style-type: none"> <li>1 Slide out both of the paper guides, and remove all paper from the IN tray.</li> <li>2 Load the transfer paper transparent (or glossy) side down.</li> <li>3 Slide the paper guides snugly against the sheets.</li> <li>4 Make sure the IN tray is pushed in.</li> <li>5 Choose the print settings that match the type and size of your iron-on transfers.</li> <li>6 Print your transfers.</li> </ol>
HP print settings to choose	Guidelines to remember
<p><b>Page Setup</b></p> <ul style="list-style-type: none"> <li>- <i>Paper Size</i>: Choose appropriate size</li> <li>- <i>Orientation</i>: Choose appropriate orientation</li> <li>- <i>Flip Horizontal</i></li> </ul> <p><b>Paper Type/Quality</b></p> <ul style="list-style-type: none"> <li>- <i>Paper Type</i>: Choose <b>HP Premium Inkjet Paper</b></li> <li>- <i>Print Quality</i>: Choose <b>Best</b></li> </ul> <p><b>Layout</b></p> <ul style="list-style-type: none"> <li>- <i>Pages per Sheet</i>: 1</li> <li>- <i>Print Both Sides</i>: Unchecked</li> </ul>	<ul style="list-style-type: none"> <li>• If you want the text or picture on your t-shirt as you see it on the screen, flip the document by clicking <b>Flip Horizontal</b>.</li> <li>• For best results, use <b>HP Iron-On T-Shirt Transfers</b>.</li> </ul>

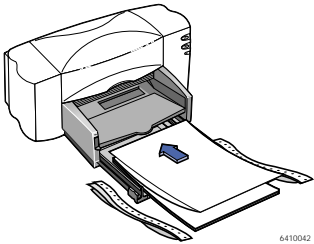

## Printing Banners

I want to print...	I should...
 <p>6410042</p>	<ol style="list-style-type: none"> <li>1 Tear off the number of sheets you need (up to 20).</li> <li>2 Tear off and discard the perforated strips, if any.</li> <li>3 Slide out the paper guides, and remove all paper from the IN tray.</li> <li>4 Raise the OUT tray and leave it in the up position to print your banners.</li> <li>5 Put the banner paper in the IN tray so that the unattached edge is at the top of the stack. Insert the first edge into the IN tray until it stops.</li> <li>6 Slide the paper guides snugly against the sheets.</li> <li>7 Make sure the IN tray is pushed in.</li> <li>8 Choose the appropriate paper type, size, and orientation from the <b>Page Setup</b> and <b>Print</b> dialog screens.</li> <li>9 Print the banner.</li> </ol>
HP print settings to choose	Guidelines to remember
<p><b>Page Setup</b></p> <ul style="list-style-type: none"> <li>- <i>Paper Size:</i> Choose <b>U.S. Letter Banner</b> or <b>A4 Banner</b></li> <li>- <i>Orientation:</i> Choose appropriate orientation</li> </ul> <p><b>Paper Type/Quality</b></p> <ul style="list-style-type: none"> <li>- <i>Paper Type:</i> Choose <b>Plain Paper</b> or <b>HP Banner Paper</b></li> <li>- <i>Print Quality:</i> Choose <b>Normal</b></li> </ul> <p><b>Layout</b></p> <ul style="list-style-type: none"> <li>- <i>Pages per Sheet:</i> 1</li> <li>- <i>Print Both Sides:</i> Unchecked</li> </ul>	<ul style="list-style-type: none"> <li>• When printing banners, be sure that the OUT tray is placed in the up position and the IN tray is pushed in.</li> <li>• For best results, use HP Banner Paper.</li> </ul>

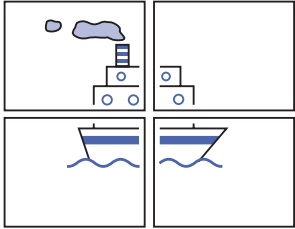

## Printing Posters

I want to print...	I should...
	<ol style="list-style-type: none"> <li>1 Load paper in the IN tray.</li> <li>2 Slide the paper guides snugly against the sheets.</li> <li>3 Make sure the IN tray is pushed in.</li> <li>4 Choose the print settings that match the type and size of your poster.</li> <li>5 Print your poster.</li> </ol>
HP print settings to choose	Guidelines to remember
<p><b>Page Setup</b></p> <ul style="list-style-type: none"> <li>- <i>Paper Size</i>: Choose appropriate size</li> <li>- <i>Orientation</i>: Choose appropriate orientation</li> </ul> <p><b>Paper Type/Quality</b></p> <ul style="list-style-type: none"> <li>- <i>Paper Type</i>: Choose <b>Plain Paper</b></li> <li>- <i>Print Quality</i>: Choose <b>Normal</b></li> </ul> <p><b>Layout</b></p> <ul style="list-style-type: none"> <li>- <i>Pages per Sheet</i>: <b>2x2 Poster</b>, <b>3x3 Poster</b>, or <b>4x4 Poster</b></li> <li>- <i>Print Both Sides</i>: Unchecked</li> </ul>	<ul style="list-style-type: none"> <li>• After printing, trim the edges on each sheet and tape the sheets together.</li> </ul>

## Two-Sided Printing

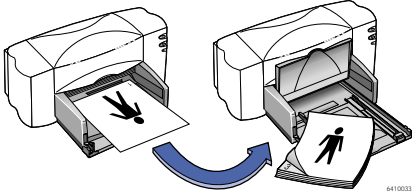
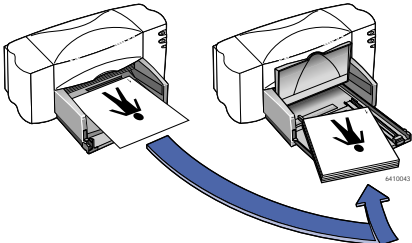
I want to print...	I should...
<p><b>Manual Two-Sided Printing</b> <b>Book Binding</b></p>  <p><b>Tablet Binding</b></p> 	<ol style="list-style-type: none"> <li>1 Remove all paper from the OUT tray.</li> <li>2 Load paper into the IN tray.</li> <li>3 Slide the paper guides snugly against the sheets.</li> <li>4 Make sure the IN tray is pushed in.</li> <li>5 In the <b>Layout</b> dialog box, click <b>Print Both Sides</b>, then select either the <b>Book</b> or <b>Tablet</b> icon, and uncheck <b>Automatic</b>.</li> <li>6 Choose the print settings that match the type and size of your paper.</li> <li>7 Begin printing.</li> <li>8 Carefully follow the reloading instructions displayed on your computer screen.</li> <li>9 When the paper is properly reloaded, click <b>Continue</b> in the message box on your computer screen.</li> </ol>
HP print settings to choose	Guidelines to remember
<p><b>Page Setup</b></p> <ul style="list-style-type: none"> <li>- <i>Paper Size</i>: Choose appropriate size</li> <li>- <i>Orientation</i>: Choose appropriate orientation</li> </ul> <p><b>Paper Type/Quality</b></p> <ul style="list-style-type: none"> <li>- <i>Paper Type</i>: Choose appropriate type</li> <li>- <i>Print Quality</i>: Choose <b>Normal</b></li> </ul> <p><b>Layout</b></p> <ul style="list-style-type: none"> <li>- <i>Pages per Sheet</i>: 1</li> <li>- <i>Print Both Sides</i>: Check this box, then choose the <b>Book</b> icon (for binding on the side) or <b>Tablet</b> icon (for binding at the top). Uncheck <b>Automatic</b>.</li> </ul>	<ul style="list-style-type: none"> <li>• The printer prints one side of the paper first. Then, a message on your computer screen tells you how to reload the paper and resume printing. The reverse side of the paper is then printed.</li> </ul>

## HP DeskJet Utility Window

The HP DeskJet Utility is located in the Utilities folder on your hard drive's main directory. The HP DeskJet Utility window has six panels, as shown below:

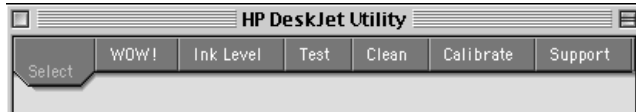

- **Select** allows you to select the **HP DeskJet 840C** from the list of printers connected to your computer (see “Select Panel” on page 25)
- **WOW!** demonstrates the HP DeskJet’s print quality
- **Test** allows you to print a test document
- **Clean** allows you to automatically clean your print cartridges
- **Calibrate** allows you to automatically align the Color and Black print cartridges
- **Support** allows you easy access to links to **HP Customer Care Online**

Simply click a panel, then choose your option(s).

**Note:** The Ink Level tab in the HP DeskJet Utility is not available with all models of HP DeskJet 840C Series printers and configurations.

### Select Panel

Use this panel when any of the functions on the Utility window prompt you to select a printer. For example, if you want to calibrate your printer by choosing the **Calibrate** panel, you will be prompted to first select your printer if it is not already selected.

To select your printer from within the **HP DeskJet 800 Series Utility** window:

- 1 Click the **Select** panel on the **Utility** window.
- 2 Select **USB**.
- 3 In the **Connect To:** list, choose the desired HP DeskJet printer.

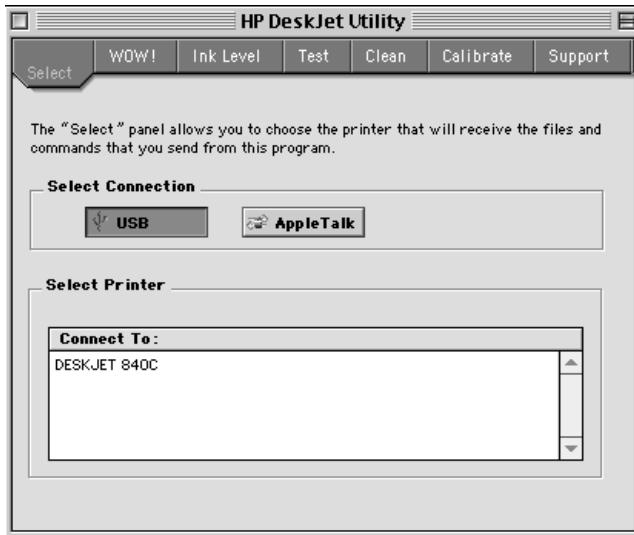



# 3 Using and Caring for Your Print Cartridges

## Print Cartridge Status

The Print Cartridge Status Light flashes when one or both of your print cartridges are low on ink, improperly installed, or malfunctioning. It will also flash if you are trying to use the wrong print cartridge type.

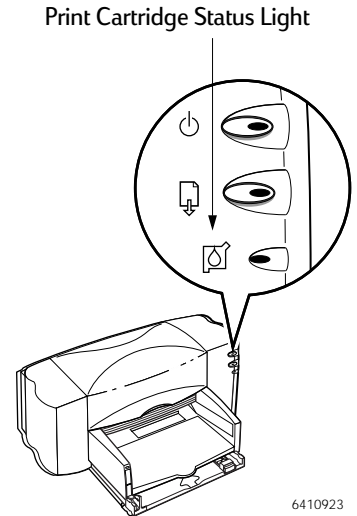

## Replacing Print Cartridges

**Note:** When buying replacement print cartridges, check the part numbers carefully. The print cartridge numbers for the 840C, 842C, and 843C printers are:

- Black HP No. [15] (equivalent to C6615 Series)
- Tri-Color HP No. [17] (equivalent to C6625 Series)

**Note:** When a print cartridge runs out of ink, leave the empty cartridge in the cradle until you can replace it. The printer does not print with only one print cartridge in the cradle.

## Using and Caring for Your Print Cartridges

### To replace a print cartridge:

- 1 Press the Power Button to turn on the printer. The print cartridges move.
- 2 Unplug the power cord from the back of the printer.
- 3 Open the top cover and raise the cradle latch.
- 4 Lift the print cartridge out of the cradle and discard it.

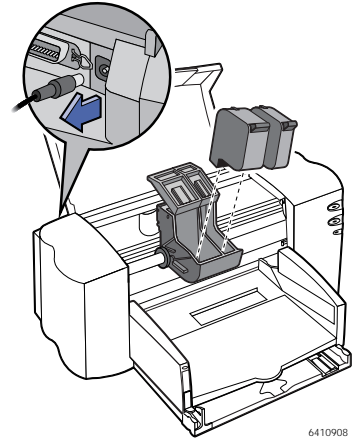

6410908

### Warning

Keep print cartridges out of the reach of children.

- 5 Remove the replacement print cartridge from its packaging and carefully remove the protective vinyl tape.

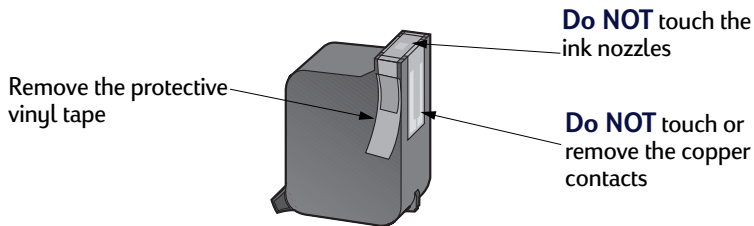

### Warning

**Do NOT** touch the print cartridge ink nozzles or copper contacts. Touching these parts will result in clogs, ink failure, and bad electrical connection. Also, **do NOT** remove the copper strips; these are required electrical contacts.

- 6 Push the print cartridge firmly, straight down into the print cartridge cradle.
- 7 Close the cradle latch. When the latch is fully closed, you will hear a click.
- 8 Load plain white paper in the IN tray.
- 9 Plug in the power cord in the back of the printer.
- 10 Close the top cover.
- 11 If the Print Cartridge Status  Light continues to blink after you install the new print cartridge, check the part number on the print cartridge to ensure you installed the correct one.

## Storing Print Cartridges

To maintain excellent print quality from your print cartridges:

- Keep all print cartridges in their sealed packages, at room temperature (60-78° F or 15.6-26.6° C), until you are ready to use them.
- Once installed, leave the print cartridges in their cradle at all times to keep them from drying out or becoming clogged.
- If you store an unsealed print cartridge, do so in an airtight plastic container.
- **Do NOT** unplug the printer until printing is complete and the print cartridge cradles have returned to their home position on the right side of the printer. The print cartridges will dry out if not stored in their home position.

### Warning

Only use the Power Button on the front of the printer to turn the printer on and off. Using a power strip, surge protector, or a wall-mounted outlet switch to turn the printer on and off may cause premature failure.

## Cleaning Print Cartridges

### When Do You Need to Clean?

Clean the print cartridges if your printed page is missing lines or dots, or if it contains ink streaks.



### If You See Missing Lines or Dots...

Clean the print cartridges from the **HP DeskJet 800 Series Utility** window by doing the following:

- 1 Double-click the **HP DeskJet 800 Series Utility** icon in the Utilities folder on your hard drive's main directory.
- 2 Click the **Clean** panel, then click the **Clean** button and follow the instructions displayed on your screen.

**Note:** Unnecessary cleaning wastes ink and shortens the life of the print cartridge.

### If You See Ink Streaks...

Clean the print cartridges and the print cartridge cradle by following the instructions below.

- 1 Double-click the **HP DeskJet 800 Series Utility** icon in the Utilities folder on your hard drive's main directory.
- 2 Click the **Clean** panel, then click the **Clean** button. If this does not prevent streaks, follow the instructions for "Manually Cleaning the Print Cartridges" below.

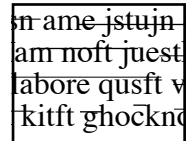

#### Caution

Be careful not to get ink on your hands or clothing.

### Manually Cleaning the Print Cartridges and Print Cartridge Cradle

In order to properly clean the print cartridges and cradle, you will need distilled or bottled water and cotton swabs or a similar lint-free absorbent material that will not stick to the cartridges.

### Manually Cleaning the Print Cartridges

- 1 Press the Power Button to turn the printer on, then lift the top cover.
- 2 After the print cartridges move to the center and stop, unplug the power cord from the back of the printer.

#### Warning

Keep new and used print cartridges out of the reach of children.

- 3 Remove the print cartridges and place them wide side down on a piece of paper.

#### Caution

**Do NOT** touch the print cartridge ink nozzles or copper contacts. Touching these parts will result in clogs, ink failure, and bad electrical connection.

Also, **do NOT** remove the copper strips; these are required electrical contacts.

- 4 Dip a clean cotton swab into distilled water and squeeze any excess water from the swab.
- 5 Clean the **face** and **edges** of the print cartridge as shown. **DO NOT** wipe the nozzle plate.
- 6 Inspect the cartridge for fibers on the face and edges. If fibers are still present, repeat the cleaning process.
- 7 Repeat the cleaning process for the other print cartridge.

**Do NOT** clean  
nozzle plate

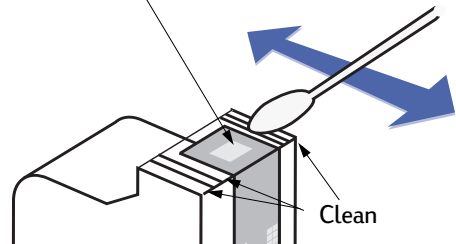

#### Caution

Once you've removed the print cartridges, make sure that they are not outside of the print cartridge cradle longer than 30 minutes.

### Manually Cleaning the Print Cartridge Cradle

- 1 Using clean, moistened swabs, wipe the underside of each wall of the cradle.
- 2 Repeat until no ink residue is seen on a clean swab.
- 3 Reinsert the print cartridges, then close the printer's top cover.
- 4 Make sure white paper is loaded into the IN tray.
- 5 Reinsert the electrical power cord into the back of the printer.
- 6 Print a test page. Double-click the **HP DeskJet 800 Series Utility** icon in the Utilities folder on your hard drive's main directory, click the **Test** panel, then click the **Test** button.

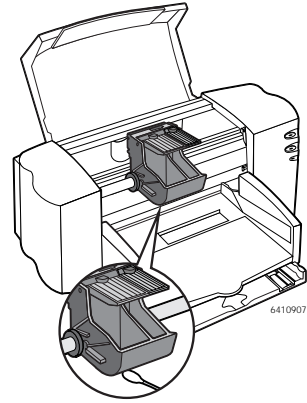

**Note:** If streaking still appears, repeat the procedure until the test printout is clean. You will find additional maintenance tips at [http://www.hp.com/support/home\\_products](http://www.hp.com/support/home_products).

### Damage Resulting from Refilling the Print Cartridges

To get the best performance from your printer, Hewlett-Packard recommends using only genuine HP supplies for HP DeskJet printers, including genuine factory-filled HP print cartridges.

Damage resulting from the modification or refilling of HP print cartridges is specifically excluded from the coverage of HP printer warranties.

**Note:** When buying replacement print cartridges, check the part numbers carefully. The print cartridge numbers for the 840C, 842C, and 843C printers are:

- Black HP No. [15] (equivalent to C6615 Series)
- Tri-Color HP No. [17] (equivalent to C6625 Series)

# 4 Getting Help When Things Go Wrong

## Troubleshooting Tips

It's frustrating when things go wrong, but the following pages contain tips that can help you determine what the problem is and how to fix it.

Be sure cable connections are secure. Check if your question is similar to those listed below and then follow the instructions found in that section:



The printer software won't install, what's wrong? See pages 33–34.



Why won't it print? See pages 35–37.



What do the flashing lights mean? See page 38.



Is there a problem with your printout? See page 39.



### The printer software won't install, what's wrong?

What is the problem?	Possible cause	To solve the problem...
I inserted a CD, but the computer couldn't read it.	<ul style="list-style-type: none"><li>The CD wasn't properly inserted.</li></ul> <i>OR</i> <ul style="list-style-type: none"><li>The CD player may be damaged.</li></ul> <i>OR</i> <ul style="list-style-type: none"><li>The CD may be damaged.</li></ul> <i>OR</i> <ul style="list-style-type: none"><li>The CD-ROM extensions may be turned off.</li></ul>	<ol style="list-style-type: none"><li>Reinsert the CD and try again. If this doesn't solve your problem...</li><li>Try inserting a CD that you know works. If that CD doesn't work, you may need to replace your CD player.</li><li>If other CD's work but the printer software CD doesn't, you may have a damaged CD. You can download the printer software from the HP Customer Care web site: <a href="http://www.hp.com/support/home_products">www.hp.com/support/home_products</a></li><li>If you don't have Web access, contact HP Customer Care. See page 43, to locate the phone number nearest you.</li><li>Go to your Extensions Manager to ensure the Apple CD extension is turned on.</li></ol>











### The printer software won't install, what's wrong? *continued*

What is the problem?	Possible cause	To solve the problem...
<p>The software did not install correctly.</p>	<ul style="list-style-type: none"> <li>• There may be a conflict with your virus protection program.</li> <li><i>OR</i></li> <li>• There may be a conflict with another software program.</li> <li><i>OR</i></li> <li>• Your printer software didn't install properly.</li> </ul>	<ol style="list-style-type: none"> <li><b>1</b> Uninstall your printer software. Insert the printer software CD into your computer, select <b>Uninstall</b> from the Installer, then repeat the installation procedure.</li> <li><b>2</b> Close any virus protection programs that are active.</li> <li><b>3</b> If you have been using Apple's QuickDraw GX software, turn it off. Your HP DeskJet printer is not compatible with QuickDraw GX.</li> <li><b>4</b> Exit all of your software programs.</li> <li><b>5</b> Reinstall the printer software. See the "Install Printer Software" step on the <i>Quick Start Poster</i> or see page 51 in this <i>User's Guide</i>.</li> </ol> <p>If you are still having problems with the software installation, call an HP authorized dealer or HP Customer Care. For the phone number of the HP Customer Care Center nearest you, see page 43.</p>

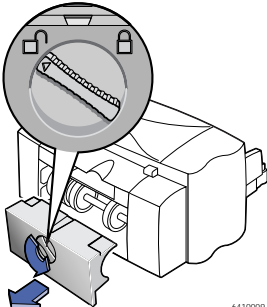

## Why won't it print?

What is the problem?	Possible cause	To solve the problem...
 <p>No page came out of the printer.</p>	<p>Power may be off or there may be a loose connection.</p>	<ol style="list-style-type: none"> <li>1 Make sure the power is on.</li> <li>2 Make sure that all cable connections are secure.</li> </ol>
	<p>You may not have any paper in the IN tray.</p>	<p>Double-check that the media is placed in the IN tray correctly.</p>
	<p>The printer's top cover may be open.</p>	<p>Close the printer's top cover.</p>
	<p>A problem may exist with one of the print cartridges.</p>	<p>If the Print Cartridge Status Light  is blinking, lift the printer's cover, check the Print Cartridge Status. Verify that the print cartridges are installed properly. See page 1.</p>
	<p>The printer may be slow.</p>	<p>If the Power Light  is blinking, the printer is in the process of printing. Be patient.</p>
	<p>The printer is waiting for you to press the Resume Button .</p>	<p>If the Resume Light is flashing, press the Resume Button .</p>
	<p>There may be a paper jam.</p>  <p style="text-align: right; font-size: small;">6410009</p>	<ol style="list-style-type: none"> <li>1 Pull the paper out of either the IN tray or the OUT tray.</li> <li>2 Press the Resume Button  on the front of the printer.</li> <li>3 If you were printing labels, make sure a label did not become unglued from the label sheet while going through the printer.</li> <li>4 If the paper jam has cleared, print your document again.</li> <li>5 If the paper jam hasn't cleared, open the Rear Access Door by turning the knob (counter-clockwise) and removing the door.</li> <li>6 Pull the jammed paper out of the printer, then replace the Rear Access Door.</li> </ol>
	<p>The Rear Access Door may be disengaged.</p>	<ol style="list-style-type: none"> <li>1 Insert the Rear Access Door and engage lock.</li> <li>2 Print your document again.</li> </ol>



### Why won't it print? *continued*

What is the problem?	Possible cause	To solve the problem...
 A blank page came out of the printer.	You may be out of ink.	<ol style="list-style-type: none"> <li>1 Lift the printer cover and check the Print Cartridge status icons to make sure you are not out of ink. See “Checking Printer Status” on page 5.</li> <li>2 If you are out of ink, replace the print cartridge. See “Replacing Print Cartridges” on page 26.</li> <li>3 Print your document again.</li> </ol>
	You may have forgotten to remove the vinyl tape from the print cartridge.	Make sure you have removed the protective piece of vinyl tape on each of the print cartridges. See “Replacing Print Cartridges” on page 26.
	You may be trying to print a fax.	<ol style="list-style-type: none"> <li>1 Save the fax in a graphic format, such as TIFF.</li> <li>2 Place it in a word processing document and print it from there.</li> </ol>











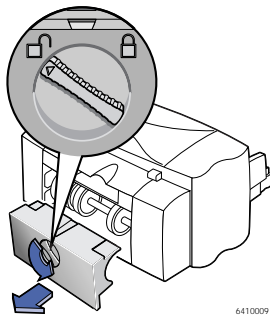

### Why won't it print? *continued*

What is the problem?	Possible cause	To solve the problem...
The printer is really slow.	Your computer may have less than the minimum system requirements.	<ol style="list-style-type: none"> <li>1 Check the amount of RAM and processor speed in your computer. See “System Requirements” on page 52.</li> <li>2 Free up some space on your hard drive. Having less than 100MB of free space on your computer’s hard drive can mean longer processing times.</li> </ol>
	Too many software programs may be running at the same time.	Close all unnecessary software programs.
	You may be using outdated printer software.	Check the printer driver you are using. Be sure to check the HP web site at <a href="http://www.hp.com/support/home_products">http://www.hp.com/support/home_products</a> for the most recent software updates.
	You may be printing a complex document containing graphics or photographs.	Be patient. Large, complex documents containing graphics or photographs print slower than text-only documents.



## What do the flashing lights mean?

What is the problem?	Possible cause	To solve the problem...
The Power Light  is flashing.	Your printer may be receiving data.	Be patient, your computer is processing the print job.
The Resume Light  is flashing.	You may be out of paper.	<ol style="list-style-type: none"> <li>1 Insert paper.</li> <li>2 Press the Resume Button .</li> </ol>
	You may have a paper jam. 	<ol style="list-style-type: none"> <li>1 Pull the paper out of either the IN tray or the OUT tray.</li> <li>2 Press the Resume Button  on the front of the printer.</li> <li>3 If you were printing labels, make sure a label did not become unglued from the label sheet while going through the printer.</li> <li>4 If the paper jam has cleared, print your document again.</li> <li>5 If the paper jam hasn't cleared, open the Rear Access Door by turning the knob (counter clockwise) and removing the door.</li> <li>6 Pull the jammed paper out of the printer, then replace the Rear Access Door.</li> </ol>
	You may be printing a two-sided document by hand and the first side has finished printing.	<ol style="list-style-type: none"> <li>1 Follow the on-screen directions for how to insert the paper.</li> <li>2 Press the Resume Button .</li> </ol>
The Print Cartridge Status Light  is flashing.	The top cover may be open.	Close the top cover.
	There may be a problem with one of the print cartridges.	See "Print Cartridge Status" on page 26.
All of the lights are flashing.	The printer may need to be reset.	<ol style="list-style-type: none"> <li>1 Press the Power Button  to turn the printer off. Then press the Power Button  again to turn the printer back on.</li> <li>2 If that doesn't solve the problem, press the Power Button  to turn the printer off.</li> <li>3 Unplug the printer.</li> <li>4 Plug the printer back in.</li> <li>5 Press the Power Button  to turn the printer on.</li> </ol>



## Is there a problem with your printout?

What is the problem?	Possible cause	To solve the problem...
 Parts of the document are missing or are in the wrong place.	Paper may not be loaded correctly.	<ol style="list-style-type: none"> <li>1 Make sure the media is correctly oriented in the IN tray.</li> <li>2 Make sure the paper guides fit snugly against the media.</li> </ol>
	You may have selected the wrong paper orientation.	Make sure you have selected the correct orientation (portrait or landscape) on the <b>Page Setup</b> dialog box. See “Page Setup - Controlling Page Layout” on page 6.
	You may have selected the wrong paper size.	Make sure you have selected the correct paper size in the <b>Page Setup</b> dialog box. See “Page Setup - Controlling Page Layout” on page 6.
	You may be trying to print text or graphics that are larger than your paper size.	Make sure text and graphics are scaled correctly in your document. See “Paper Size, Scaling, and Page Orientation” on page 6.
	You may have selected the wrong margins.	Make sure the margins are within the printable area. See “Minimum Printing Margins” on page 54.
	You may have accidentally left <b>Poster Printing</b> selected.	Uncheck <b>Poster Printing</b> in the <b>Layout</b> panel. See “Layout” on page 9.





## Is there a problem with your printout? *continued*

What is the problem?	Possible cause	To solve the problem...
 <p>Print quality is poor.</p>	<p>You may not be using the most appropriate media for the desired output.</p>	<ul style="list-style-type: none"> <li>- Make sure that you are using media intended for HP DeskJet printers.</li> <li>- Print quality is dramatically improved if you print on paper specifically designed for a certain output (photographs, for example), rather than using plain paper.</li> </ul>
	<p>You may be printing on the wrong side of the media.</p>	<p>Make sure that the media is loaded print side down.</p>
	<p>You may not have selected the correct paper type in the printer software.</p>	<p>Make sure that you have selected the correct paper type on the <b>Paper Type/Quality</b> dialog box. See “Paper Type/Quality” on page 9.</p>
	<p>You may be printing in Draft mode.</p>	<p>If printing appears faded or dull, click <b>Normal</b> or <b>Best</b> instead of Draft on the <b>Paper Type/Quality</b> dialog box. See “Paper Type/Quality” on page 9.</p>
	<p>If you have smearing, you may be using too much ink.</p>	<ol style="list-style-type: none"> <li>1 Click <b>Normal</b> or <b>Draft</b> instead of Best on the <b>Paper Type/Quality</b> dialog box. See “Paper Type/Quality” on page 9.</li> <li>2 Reduce the amount of ink. From the <b>HP DeskJet 800 Series Print</b> dialog box, select the <b>Ink Controls</b> panel. Use the sliders to adjust ink volume.</li> <li>3 Increase the dry time. From the <b>HP DeskJet 800 Series Print</b> dialog box, select the <b>Ink Controls</b> panel. Use the sliders to adjust dry time.</li> </ol>
	<p>You may be running out of ink.</p>	<ol style="list-style-type: none"> <li>1 Check the print cartridges status. See “Print Cartridge Status” on page 26.</li> <li>2 If you are running out of ink, replace the print cartridge. See “Replacing Print Cartridges” on page 26.</li> </ol>
	<p>You may need to clean the print cartridges.</p>	<p>See “Cleaning Print Cartridges” on page 29.</p>



## Is there a problem with your printout? *continued*

What is the problem?	Possible cause	To solve the problem...
 Print quality is poor. (continued)	You may have forgotten to remove the vinyl tape from the print cartridge.	Make sure that you have removed the protective piece of vinyl tape on each of the print cartridges. See “Replacing Print Cartridges” on page 26.
	You may have the incorrect “Image” setting in the <b>Color</b> panel of the <b>Print</b> dialog box.	Click the <b>Revert to Defaults</b> button in the <b>Color</b> panel of the <b>Print</b> dialog box. See “Color” on page 10.
	Your print cartridges may be out of alignment.	If the color and black ink aren’t lining up on the printed page, go to the <b>HP DeskJet 800 Series Utility</b> located in the Utilities folder in your hard drive’s main directory. Click the <b>Calibrate</b> panel, then click the <b>Align</b> button. See “HP DeskJet Utility Window” on page 24.
 Banners aren’t printing correctly.	You may have forgotten to raise the OUT tray.	Make sure that the OUT tray is up.
	You may have problems with the paper.	<ul style="list-style-type: none"> <li>- If several sheets feed into the printer together, unfold and refold the paper.</li> <li>- If the paper creases going through the printer, the paper might be unsuitable for banner printing.</li> </ul>
	You may have problems with your banner software.	Make sure you selected the paper size U.S. Letter Banner or A4 Banner on the Page Setup dialog box. See “Page Setup - Controlling Page Layout” on page 6.
Binding margin appears in the wrong place when trying to do Two-Sided Printing.	You may have selected the wrong paper orientation.	<ul style="list-style-type: none"> <li>- Make sure you have selected the correct <b>Binding</b> option in the <b>Layout</b> panel of the <b>Print</b> dialog box. See “Layout” on page 9.</li> </ul>



## HP Customer Care



HP DeskJet printers set the standard for quality and reliability, so you have made an excellent choice. Should you

need help, however, HP Customer Care's award-winning service and support is nearby to provide expert advice on using your HP printer or to answer specific questions about a problem you are having. Whether online or by phone, you'll find the support you need—and you'll find it fast.

### HP Customer Care Online

Click your way to a quick solution! **HP Customer Care Online** is a great place to go for answers to questions about your HP products. You'll get instant access to everything from helpful printing tips to the latest product and software updates—24 hours a day, seven days a week, all at no charge to you.

If you have a modem connected to your computer and subscribe to an online service or have direct access to the Internet, you can obtain a wide variety of information about your printer at the following web sites:

**English:**

[http://www.hp.com/support/home\\_products](http://www.hp.com/support/home_products)

**French:**

<http://www.hp.com/cposupport/fr/>

**German:**

<http://www.hp.com/cposupport/de>

**Japanese:**

[http://www.jpn.hp.com./CPO\\_TC/eschome.htm](http://www.jpn.hp.com./CPO_TC/eschome.htm)

**Portuguese:**

<http://www.hp.com/cposupport/pt>

**Spanish:**

<http://www.hp.com/cposupport/es/>

From HP Customer Care Online you can link to **HP Customer Care User Forums** and **HP Customer Care Email**.

### HP Customer Care User Forums

They're friendly. They're informative. Check out our online user forums. Simply review existing messages left by other HP users to find the answers you're looking for. You can also post your questions, then check back later for ideas and suggestions from knowledgeable users and system operators.

### HP Customer Care by Email

Connect with HP via email and receive a personal reply from an HP Customer Care service technician. Responses are normally provided within 24 hours of receipt (excluding holidays). A great option for those non-urgent questions.

### Printer Software

Printer software (also referred to as a printer driver) allows your printer to talk with your computer. HP provides several options for getting printer software and software updates:

- Download the printer software by accessing the **HP Customer Care Online** web site. See "HP Customer Care Online" on page 42 for the addresses of the HP web sites.
- If you are in the U. S. and need a software update, you can download the printer software from: [http://www.hp.com/support/home\\_products](http://www.hp.com/support/home_products). If you do not have access to the web site, call (661) 257-5565. Software updates are available for the cost of the CDs plus shipping.
- If you are outside the U.S. and cannot download the driver from **HP Customer Care Online** (see page 42), call the **HP Customer Care Center** (page 43) nearest you.



### HP Customer Care Repair

If your HP printer is ever in need of repair, simply call the **HP Customer Care Center**. A trained service technician will diagnose the problem and coordinate the repair process for you. This service is free during your printer's standard warranty. Beyond the warranty period, repairs are charged on a time and materials basis.



### HP Customer Care by Phone

Within the period specified below from the time of your purchase, telephone support is provided to you free of charge. However, if you are calling long distance, long-distance charges may apply.

#### Free Phone Support Period

In This Region:	Your Free Phone Support Period is:
North America & Canada	None, fee based
Asia Pacific	90 days
Europe	6 months
Latin America	6 months

Before placing a call for help, please make sure that:

- 1 You have checked your *Quick Start Poster* and this *User's Guide* for installation and troubleshooting tips.
- 2 You have checked **HP Customer Care Online** (see page 42) for product help.
- 3 If you cannot solve your problem using the above, then call HP Customer Care while you're in front of your computer and printer. Before you call, be sure you have the following information:

- Your printer's serial number (the label is on the printer's bottom).

\_\_\_\_\_

- Your printer's model number (the label is on the front of the printer).

\_\_\_\_\_

- The model of the computer.

\_\_\_\_\_

- The version of the printer and software program (if applicable).

\_\_\_\_\_

Then we can help you with your questions immediately!

See the list below for your country's **HP Customer Care Center** phone number:

Africa/Middle East	41 22/780 41 11
Argentina	(541) 778-8380
Australia	+61 3 8877 8000
Austria	43 (0) 660 6386
Belgium (Dutch)	32 (0)2 62688 06
Belgium (French)	32 (0)2 62688 07
Brazil	011 829-6612
Canada	(905) 206-4663
Chile	800 36 0999
China	8610-65645959
Czech Republic	42 (2) 471 7321
Denmark	45 (0) 39 294099
Finland	358 (9) 2034 7288
France	33 (0) 143623434
Germany	49 (0) 180 532 6222
Greece	30 1 689 64 11
Hong Kong	(800) 96 7729
Hungary	36 (1) 252 4505
India	91 11 682 60 35
Indonesia	6221 350 3408
Ireland	353 (0) 1662 5525
Israel	972-9-9524848
Italy	39 (0) 2 264 10350
Japan, Tokyo	81 3 3335-8333
Japan, Osaka	81 6 6838 1155
Korea	02 3270 0700
Malaysia	03 2952566
Mexico D.F.	258 9922
Mexico, Guadalajara	01 800 472 6684
Middle East/Africa	41 22/780 41 11
Netherlands	31 (0) 20 606 8751
New Zealand	(09) 356-6640
Norway	47 (0) 22 116299
Philippines	65 272 5300
Poland	(+48) 22 519 06 00
Portugal	351 (0) 1 318 00 65
Russia	7095 923 50 01
Singapore	65 272 5300
Spain	34 (9) 02321 123
Sweden	46 (0) 8 6192170
Switzerland	41 (0) 84 8801111
Taiwan	886 2-2717-0055
Thailand	(66-2) 661 4011
Turkey	90 1 224 59 25
United Kingdom	44 (0) 171 512 5202
U.S.	(208) 344-4131
Venezuela	800 47 888
Venezuela, Caracas	207 8488

## After the Free Phone Support Period

You can still get help from HP for a fee. Prices are subject to change without notice. (**HP Customer Care Online** help (see page 42) on the internet is still available for free!)

- For quick questions in the United States only, call (900) 555-1500. The charges are \$2.50 per minute and begin when you connect with a support technician.
- For calls from Canada, or for calls in the U.S. that you anticipate might be longer than ten minutes in length, call (800) 999-1148. The fee is US \$25 per call, charged to your Visa or MasterCard.
- If, during your phone call, it is determined that your printer requires repair and you are within your printer's Limited Warranty period (see page 56, Printer), you will not be charged for the phone support service. However, for countries where the above toll-free phone numbers are not available, the regular long-distance charges may apply.

## Extended Warranty Options

If you would like to extend your printer coverage beyond the one year factory warranty, you have the following options:

- Consult your reseller to get extended coverage.
- If your reseller does not offer service contracts, please call HP directly and ask about our HP Service Agreements. In the U.S., call (800) 446-0522; in Canada, call (800) 268-1221. For HP Service Agreements outside the U.S. and Canada, contact your local HP Sales Office.

# 5

## Supplies and Accessories

### Printer Supplies

For ordering information see page 47.

Part Name	Part Number
<b>Interface Cables</b>	
HP USB-Compliant Interface Cable	C6518A
<b>Print Cartridges</b>	
● Black	HP No. [I5] or C6615 Series
● Tri-color	HP No. [I7] or C6625 Series
<b>Power Adapter (worldwide)</b>	C6409-60014
<b>Power Cords</b>	
U.S., Canada, Brazil, Latin America, Saudi Arabia	8120-8330
Japan	8120-8336
Singapore, Malaysia, Hong Kong	8120-8719
South Africa	8120-8347
India	8120-8345
Argentina	8120-8434
Australia	8120-8337
China, Taiwan, Philippines	8120-8346
Korea	8120-8339
Europe, Jordan, Lebanon, North Africa, Israel, Russia, Baltic countries, Thailand, Indonesia, Caribbean, Latin America	8120-8340
U.K., Middle East	8120-8341
<b>Other Replaceable Parts</b>	
DJ840C Series Printer Cleanout Access Door Assembly	C6413-60001

### Printer Quick Start Posters and User's Guide for Macintosh

Most HP printer documentation is available for viewing and printing at [http://www.hp.com/support/home\\_products](http://www.hp.com/support/home_products).

Language	Part Number	
	Quick Start Poster	User's Guide
Dutch	C6419-90010	C6419-90002
English	C6419-90009	C6419-90001
French	C6419-90009	C6419-90003
German	C6419-90010	C6419-90004
Italian	C6419-90010	C6419-90005
Portuguese	C6419-90009	C6419-90006
Spanish	C6419-90009	C6419-90007
Swedish	C6419-90010	C6419-90008

## Paper and Other Media

Availability of special media varies by country.

Paper Type/Description	Part Number	Paper Type/Description	Part Number
<b>HP Bright White InkJet Paper</b>		<b>HP Matte Greeting Cards, White/Quarter-fold</b>	
A4 (210 x 297 mm), 200 sheets	C5977A	A4 (210 x 297 mm), 20 sheets, 20 envelopes	C6042A
A4 (210 x 297 mm), 500 sheets	C1825A	U.S. letter, 20 sheets, 20 envelopes	C1812A
U.S. letter, 200 sheets	C5976A		
U.S. letter, 500 sheets	C1824A		
<b>HP Premium InkJet Paper</b>		<b>HP Glossy Greeting Cards, White/Half-fold</b>	
A4 (210 x 297 mm), 200 sheets	C51634Z	A4 (210 x 297 mm)	C6045A
U.S. letter, 200 sheets	C51634Y	10 sheets, 10 envelopes	
		U.S. letter, 20 sheets, 20 envelopes	C6044A
<b>HP Professional Brochure &amp; Flyer Paper, Matte</b>		<b>HP Iron-on T-Shirt Transfers</b>	
U.S. letter, 50 sheets	C6955A	European A4 (210 x 297 mm), 10 sheets	C6050A
		Asian A4, (210 x 297 mm), 10 sheets	C6065A
		U.S. letter, 10 sheets	C6049A
<b>HP Photo Paper, Two-Sided, Satin/Glossy</b>		<b>HP Restickables, Large Round InkJet Stickers</b>	
Asian A4 (210 x 297 mm), 20 sheets	C6765A	U.S. letter, 10 sheets (90 stickers)	C6822A
European A4 (210 x 297 mm), 20 sheets	C1847A		
U.S. letter, 20 sheets	C1846A	<b>HP Restickables, Large Square InkJet Stickers</b>	
		U.S. letter, 10 sheets (90 stickers)	C6823A
<b>HP Premium Inkjet Transparency Film</b>			
A4 (210 x 297 mm), 20 sheets	C3832A		
A4 (210 x 297 mm), 50 sheets	C3835A		
U.S. letter, 20 sheets	C3828A		
U.S. letter, 50 sheets	C3834A		
<b>HP Premium InkJet Rapid-dry Transparencies</b>			
A4 (210 x 297 mm), 50 sheets	C6053A		
U.S. letter, 50 sheets	C6051A		
<b>HP Banner Paper</b>			
A4 (210 x 297 mm), 100 sheets	C1821A		
U.S. letter, 100 sheets	C1820A		

**Note:** To find out which recycled papers are recommended for your printer, contact your local HP Sales Office and ask for the HP InkJet Printer Family Paper Specifications Guide, HP part number 5961-0920.

## Ordering Information

To order printer supplies or accessories, call your nearest HP dealer or call HP DIRECT at the following numbers for fast shipping service.

In the U.S., you can buy supplies and accessories directly from HP at [www.hpshopping.com](http://www.hpshopping.com), or call the HP Shopping Village at 1-888-999-4747.

- **Argentina:** (54 1) 787-7100  
Fax: (54 1) 787-7213  
Hewlett-Packard Argentina,  
Montañeses 2150 1428  
Buenos Aires, Argentina
- **Australia/New Zealand:** (03) 895-2895  
China Resources Bldg.  
26 Harbour Road  
Wanchai, Hong Kong
- **Austria-South-East Area:** (43-0222) 25 000, ext. 755  
Fax: (43-0222) 25 000, ext. 610  
Hewlett-Packard Ges.m.b.H.  
Ersatzteilverkauf Liebg. 1  
A-1222 Wien
- **Belgium:** 02/778 3092 (or 3090, 3091)  
Fax: 02/778 3076  
Hewlett-Packard Belgium SA/NV  
100 bd. de la Woluwe/Woluwedal  
1200 BRUXELLES
- **Brazil:** Centro de Informacoes HP  
Grande São Paulo: 822-5565  
Demais Localidades: 0800-157751  
Fax: (011) 829-7116  
Centro de Informacoes HP  
Hewlett Packard Brasil S.A.  
Caixa Postal 134, Rua Clodomiro Amazonas, 258  
CEP 04534-011, São Paulo - SP
- **Canada:** (800) 387-3154, (905) 206-4725  
Fax: (905) 206-3485/-3739  
Hewlett-Packard (Canada) Ltd.  
5150 Spectrum Way  
Mississauga, Ontario L4W 5G1  
Toronto: (416) 671-8383
- **Chile:** (56 2) 203-3233  
Fax: (56 2) 203-3234  
Hewlett-Packard de Chile SA  
Av. Andres Bello 2777, Oficina 1302  
Los Condes, Santiago, Chile
- **Denmark:** 45 99 14 29  
Fax: 42 81 58 10  
Hewlett-Packard A/S  
Kongevejen 25, 3460 BIRKEROD
- **Finland:** (90) 8872 2397  
Fax: (90) 8872 2620  
Hewlett-Packard Oy  
Varaosamynti, Piispankalliontie 17  
02200 ESPOO
- **France:** (1) 40 85 71 12  
Fax: (1) 47 98 26 08  
EuroParts  
77 101 avenue du Vieux Chemin de Saint-Denis  
92625 GENNEVILLIERS
- **Germany:** 07031-145444  
Fax: 07031-141395  
Hewlett-Packard GmbH, HP Express Support  
Ersatzteil-Verkauf, Herrenberger Str. 130  
71034 BÖBLINGEN
- **International Sales Branch:** (41) 22 780 4111  
Fax: (41) 22 780-4770  
Hewlett-Packard S. A., ISB  
39, rue de Veyrot 1217 MEYRIN 1  
GENEVE - SUISSE
- **Italy:** 02/9212.2336/2475  
Fax: 02/92101757  
Hewlett-Packard Italiana S. P. A.  
Ufficio Parti di ricambio  
Via G. Di Vittorio, 9  
20063 Cernusco s/N (MI)
- **Japan:** (03) 3335-8333  
Hewlett-Packard Japan Ltd.  
29-21 Takaido-Higashi 3-chone, sugninami-ku  
Tokyo 168-8585
- **Latin America Headquarters:** (305) 267-4220  
Fax: (305) 267-4247  
5200 Blue Lagoon Drive, Suite 950  
Miami, FL 33126
- **Mexico:** (52 5) 258-4600  
Fax: (54 1) 258-4362  
Hewlett-Packard de México, S.A. de C.V.  
Prolongación Reforma #470  
Colonia Lomas de Santa Fe, C.P. 01210 México, D.F.

- **Netherlands:** 0 33 450 1808  
Fax: 0 33 456 0891  
Hewlett-Packard Nederland B. V.  
Parts Direct Service  
Basicweg 10  
3821 BR AMERSFOORT
- **Norway:** 22735926  
Fax: 22735611  
Hewlett-Packard Norge A/S, Express Support  
Drammensveien 169-171  
0212 Oslo
- **Spain:** 1 6 31 14 81  
Fax: 1 6 31 12 74  
Hewlett-Packard Española S.A.  
Departamento de Venta de Piezas  
Ctra N-VI, Km. 16,500  
28230 LAS ROZAS, Madrid
- **Sweden:** 8-4442239  
Fax: 8-4442116  
Hewlett-Packard Sverige AB  
Skalholtsgatan 9, Box 19  
164 93 KISTA
- **Switzerland:** 056/279 286  
Fax: 056/279 280  
Elbatex Datentechnik AG  
Schwimmbadstrasse 45, 5430 WETTINGEN
- **United Kingdom:**  
+44 1765 690061  
Fax: +44 1765 690731  
Express Terminals, 47 Allhallowgate  
Ripon, North Yorkshire
- +44 181 568 7100  
Fax: +44 181 568 7044  
Parts First, Riverside Works  
Isleworth, Middlesex, TW7 7BY
- +44 1734 521587  
Fax: +44 1734 521712  
Westcoast, 28-30 Richfield Avenue  
Reading, Berkshire, RG1 8BJ
- **United States:** (800) 227-8164
- **Venezuela:** (58 2) 239-4244/4133  
Fax: (58 2) 207-8014  
Hewlett-Packard de Venezuela C.A.  
Tercera Transversal de Los Ruices Norte  
Edificio Segre, Caracas 1071, Venezuela  
Apartado Postal 50933, Caracas 1050

#### Elsewhere in the world

- **Hewlett-Packard Company**  
Intercontinental Headquarters,  
3495 Deer Creek Road,  
Palo Alto, CA 94304, U.S.A.

# A Setup Instructions

## Using a USB Connection

You can connect your HP DeskJet 800 Series directly to your computer using a USB cable if your computer supports USB (Universal Serial Bus). Before you connect your printer to your computer, make sure your configuration meets these requirements:

- Your computer must support USB
- You will need a USB-compliant interface cable, such as HP Part Number C6518A
- Your computer must be turned on and running MacOS 8.1 or higher

### 1 Plug in Electrical Power Cord

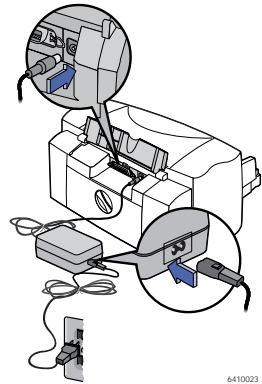

6410023

### 2 Load White Paper

- a** Pull out the IN tray and slide the paper guides out as far as possible to make room for the paper. If desired, flip up the OUT tray for a better view of the IN tray.
- b** Put a stack of paper into the IN tray, print side down. You can insert up to 10 mm (3/8 inch) at a time.
- c** Push the paper toward the back of the paper tray until it stops.
- d** Slide both paper guides to fit snug against the paper's edges.
- e** Slide the IN tray all the way back in. If it is up, flip down the OUT tray.

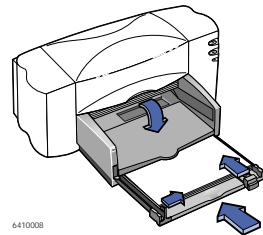

6410008



### 3 Insert Print Cartridge

- a Press Power Button  to turn on printer.
- b Remove vinyl tape from print cartridges. **Do NOT** touch or remove copper strip on print cartridges.

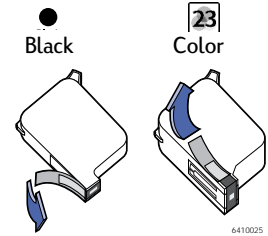

- c Open top cover.

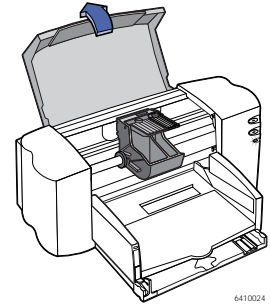

- d For each print cartridge, lift the cradle latch inside the printer. With the copper electrical contacts toward the rear of the printer and the print cartridge held vertically, push the print cartridge firmly down into the cradle. Insert the black print cartridge in the right cradle and insert the tri-color print cartridge in the left cradle. You must insert both print cartridges for the printer to operate. Close the latches. You will hear a click and feel resistance when the cradle is pushed down.

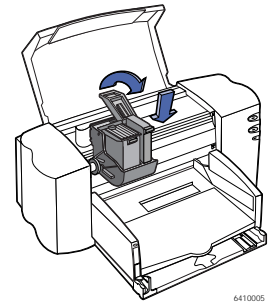

- e Close top cover.

#### 4 Connect USB Cable

- You can connect to any USB port.
- A USB cable, such as an HP USB-Compliant Interface Cable (part number C6518A), should be purchased separately.
  - a Lift open the cable access door on the back of the printer.
  - b Plug one end of the USB cable into the USB port on the printer.
  - c Plug the other end of the USB cable into the USB port on the computer.

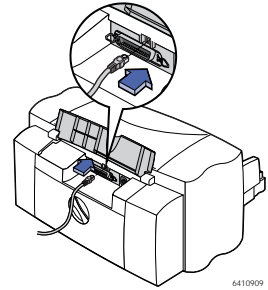

#### 5 Install Printer Software

- a Insert the HP Printer Software CD into your CD-ROM drive.
- b Double-click the HP DeskJet Mac Installer icon.



HP DeskJet Mac Installer
- c Follow the on-screen instructions to complete the installation. Your computer will restart when the installation is complete.
- d After your computer restarts, the HP DeskJet Utility (Select Printer) dialog box opens. Follow the instructions in this dialog box to select the HP DeskJet 800 Series printer.

# B Specifications

## DeskJet 843C model no. C6414C

### Black Text Print Speed\*

Draft: 9 pages per min.

### Mixed Text with Color Graphics Print Speed\*

Draft: 6.5 pages per min.

### Duty Cycle

1,000 pages per month

## DeskJet 840C model no. C6414A DeskJet 842C model no. C6414B

### Black Text Print Speed\*

Draft: 8 pages per min.

### Mixed Text with Color Graphics Print Speed\*

Draft: 5 pages per min.

### Duty Cycle

1,000 pages per month

## The following apply to the HP DeskJet 840C, 842C, and 843C Series printers.

### Black TrueType™ Text Resolution (depends on paper type)

Draft: 300 x 600 dpi

Normal: 600 x 600 dpi

Best: 600 x 600 dpi

### Color Resolution (depends on paper type)

Draft: 300 x 600 dpi

Normal: Color Layering

Best: Color Layering

### Print Technology

Drop-on-demand thermal inkjet printing

### Software Compatibility

USB Connection: MacOS version 8.1 or later

### System Requirements

USB Connection:

PowerPC MacOS computer with a USB port  
MacOS version 8.1 or later

32 MB RAM

8 MB (minimum) available hard-disk space

### Buttons/Lights

Print Cartridge Status Light

Resume Button and Light

Power Button and Light

### I/O Interface

Universal Serial Bus

### Dimensions

446 mm wide x 185 mm high x 335 mm deep

17.56 in wide x 7.2 in high x 13.8 in deep

### Weight

5.5 kg (12 lb) without power supply and  
print cartridges

### Operating Environment

Maximum operating temperature:

41 to 104 °F, 5 to 40 °C

Humidity: 15 to 80% RH noncondensing

Recommended operating conditions for best print  
quality:

59 to 95 °F or 15 to 35 °C

20 to 80% RH noncondensing

Storage temperature: -40 to 140 °F, -40 to 60 °C

### Power Consumption

5 watts average maximum when off

5 watts average maximum non-printing

25 watts average maximum when printing

### Power Requirements

Input Voltage: 100 to 240 VAC (±10%)

Input Frequency: 50/60 Hz (±3 Hz)

Automatically accommodates the world-wide range  
of AC line voltages and frequencies. There is no on/  
off switch on the power adapter.

\* Approximate figures. Exact speed will vary depending on the system configuration, software program, and document complexity.

## Specifications

### Declared noise emissions in accordance with ISO 9296:

Sound power level, LWAd (1B=10dB): 5.5 B in Normal mode.

Sound pressure level, LpAm (bystander positions): 42 dB in Normal mode.

### Media Weight

Paper:	60 to 200 gsm (16 to 110 lb index)
Envelopes:	75 to 90 gsm (20 to 24 lb)
Cards:	110 to 200 gsm; 0.3 mm max thickness (110 lb index max; 0.012 inch max thickness)
Banner Paper:	75 gsm (20 lb)

### Media Handling

Sheets:	up to 100 sheets
Banners:	up to 20 sheets
Envelopes:	up to 15 envelopes
Cards:	up to 30 cards
Transparencies:	up to 25 sheets
Labels:	up to 20 sheets of paper labels Use only U.S. letter-sized or A4-sized sheets. Use only paper labels specifically designed for use with HP inkjet printers.
OUT tray capacity:	up to 50 sheets

### Media Size

Custom size:	
Width:	77 to 216 mm (3.0 to 8.5 in)
Length:	77 to 356 mm (3 to 14 in)
U.S. Letter:	216 x 279 mm (8.5 x 11 in)
Banner U.S. Letter:	216 x 279 mm (8.5 x 11 in)
U.S. Legal:	216 x 356 mm (8.5 x 14 in)
Executive:	184 x 267 mm (7.25 x 10.5 in)
U.S. No. 10 envelope:	105 x 241 mm (4.13 x 9.5 in)
Invitation A2 envelope:	4.37 x 5.75 in
Index card:	76 x 127 mm (3 x 5 in)
Index card:	102 x 152 mm (4 x 6 in)
Index card:	127 x 203 mm (5 x 8 in)
European A4:	210 x 297 mm
European A5:	148 x 210 mm
Banner European A4:	210 x 297 mm
B5-JIS:	182 x 257 mm
European DL envelope:	220 x 110 mm
European C6 envelope:	114 x 162 mm
European A6 card:	105 x 148 mm
Japanese Hagaki postcard:	100 x 148 mm

## Minimum Printing Margins

The printer cannot print outside a certain area of the page, so you must make sure the contents of your document fall within the printable area—that is, within the top, bottom, left, and right margins available for the specific size of paper on which you are printing.

When you use nonstandard paper sizes and select the **Custom Paper Size** setting in the HP print settings box, the paper width must be between 77 and 215 mm (3 and 8.5 inches) and the paper length must be between 77 and 356 mm (3 and 14 inches).

### A4-Sized Paper

Left:	3.2 mm (0.125 in.)
Right:	3.2 mm (0.125 in.)
Top:	1.0 mm (0.04 in.)
Bottom:	11.7 mm (0.46 in.)

### Margins for Letter-, Legal-, and Executive-Sized Paper

Left:	6.4 mm (0.25 in.)
Right:	6.4 mm (0.25 in.)
Top:	1.0 mm (0.04 in.)
Bottom:	11.7 mm (0.46 in.)

### A5-Sized Paper

Left:	3.2 mm (0.125 in.)
Right:	3.2 mm (0.125 in.)
Top:	1.0 mm (0.04 in.)
Bottom:	11.7 mm (0.46 in.)

### B5-Sized Paper

Left:	3.2 mm (0.125 in.)
Right:	3.2 mm (0.125 in.)
Top:	1.0 mm (0.04 in.)
Bottom:	11.7 mm (0.46 in.)

### Cards (3x5, 4x6, 5x8, and A6)

Left:	3.2 mm (0.125 in.)
Right:	3.2 mm (0.125 in.)
Top:	1.0 mm (0.04 in.)
Bottom:	11.7 mm (0.46 in.)

### Hagaki Postcards

Left:	3.2 mm (0.125 in.)
Right:	3.2 mm (0.125 in.)
Top:	1.0 mm (0.04 in.)
Bottom:	11.7 mm (0.46 in.)

### Envelopes

Left:	1.0 mm (0.04 in.)
Right:	11.7 mm (0.46 in.)
Top:	3.2 mm (0.125 in.)
Bottom:	3.2 mm (0.125 in.)

### Banners - A4 Sized (8.27 x 11.7 in.)

Left:	3.2 mm (0.125 in.)
Right:	3.2 mm (0.125 in.)
Top:	0.00 mm (0.0 in.)
Bottom:	0.00 mm (0.0 in.)

### Banners - Letter Sized (8.5 x 11 in.)

Left:	3.2 mm (0.125 in.)
Right:	3.2 mm (0.125 in.)
Top:	0.00 mm (0.0 in.)
Bottom:	0.00 mm (0.0 in.)

# C Legal Information

## Regulatory Notices

Hewlett-Packard Company

This device complies with part 15 of the FCC Rules. Operation is subject to the following two conditions: (1) This device may not cause harmful interference, and (2) this device must accept any interference received, including interference that may cause undesired operation.

Pursuant to Part 15.21 of the FCC Rules, any changes or modifications to this equipment not expressly approved by Hewlett-Packard Company may cause harmful interference, and void your authority to operate this equipment. Use of a shielded data cable is required to comply with the Class B limits of Part 15 of the FCC Rules.

For further information, contact:

Hewlett-Packard Company  
Manager of Corporate Product Regulations  
3000 Hanover Street  
Palo Alto, Ca 94304  
(415) 857-1501

NOTE: This equipment has been tested and found to comply with the limits for a Class B digital device, pursuant to part 15 of the FCC rules. These limits are designed to provide reasonable protection against harmful interference in a residential installation.

This equipment generates, uses, and can radiate radio frequency energy and, if not installed and used in accordance with the instructions, can cause harmful interference to radio communications.

However, there is no guarantee that interference will not occur in a particular installation. If this equipment does cause harmful interference to radio or television reception, which can be determined by turning the equipment off and on, the user is encouraged to try to correct the interference by one or more of the following measures:

- Reorient or relocate the receiving antenna.
- Increase the separation between the equipment and the receiver.
- Connect the equipment into an outlet on a circuit different from that to which the receiver is connected.
- Consult the dealer or an experienced radio/TV technician for help.

### LED Indicator Statement

The display LEDs meet the requirements of EN 60825-1.

この装置は、情報処理装置等電波障害自主規制協議会（VCCI）の基準に基づくクラスB情報技術装置です。この装置は、家庭環境で使用することを目的としていますが、この装置がラジオやテレビジョン受信機に近接して使用されると受信障害を引き起こすことがあります。  
取り扱い説明書に従って正しい取り扱いをして下さい。

#### 사용시 안내문 (A급 기기)

이 기기는 업무용으로 전자파장애검정을 받은 기기이오니, 만약 잘못 구입하셨을 때에는 구입한 곳에서 비업무용으로 교환하시기 바랍니다.

#### 사용자 안내문 (B급 기기)

이 기기는 비업무용으로 전자파장애검정을 받은 기기로서, 주거지역에서는 물론 모든 지역에서 사용할 수 있습니다.

## Limited Warranty Statement

HP Product	Duration of Limited Warranty
Ink cartridges	90 Days
Software in North America/Canada	90 Days
Software in Asia Pacific, Europe	1 Year
Software in Latin America	1 Year
Printer in North America/Canada	90 Days
Printer in Asia Pacific, Europe	1 Year
Printer in Latin America	1 Year

### A. Extent of Limited Warranty

- Hewlett-Packard (HP) warrants to the end-user customer that the HP products specified above will be free from defects in materials and workmanship for the duration specified above, which duration begins on the date of purchase by the customer. Customer is responsible for maintaining proof of date of purchase.
- For software products, HP's limited warranty applies only to a failure to execute programming instructions. HP does not warrant that the operation of any product will be uninterrupted or error free.
- HP's limited warranty covers only those defects which arise as a result of normal use of the product, and do not apply to any:
  - Improper or inadequate maintenance or modification;
  - Software, interfacing, media, parts, or supplies not provided or supported by HP; or
  - Operation outside the product's specifications.
- For HP printer products, the use of a non-HP ink cartridge or a refilled ink cartridge does not affect either the warranty to the customer or any HP support contract with the customer. However, if printer failure or damage is attributable to the use of a non-HP or refilled ink cartridge, HP will charge its standard time and materials charges to service the printer for the particular failure or damage.
- If HP receives, during the applicable warranty period, notice of a defect in any software, media, or ink cartridge product which is covered by HP's warranty, HP shall replace the defective product. If HP receives, during the applicable warranty period, notice of a defect in any hardware product which is covered by HP's warranty, HP shall either repair or replace the defective product, at HP's option.
- If HP is unable to repair or replace, as applicable, a defective product which is covered by HP's warranty, HP shall, within a reasonable time after being notified of the defect, refund the purchase price for the product.
- HP shall have no obligation to repair, replace, or refund until the customer returns the defective product to HP.
- Any replacement product may be either new or like-new, provided that it has functionality at least equal to that of the product being replaced.
- HP's limited warranty is valid in any country where the covered HP product is distributed by HP except for the Middle-East, Africa, Argentina, Brazil, Mexico, Venezuela, and France's "Departements D'Outre-Mer"; for those excepted areas, the warranty is valid only in the country of purchase. Contracts for additional warranty services, such as on-site service, may be available from any authorized HP service facility where the product is distributed by HP or by an authorized importer.

### B. Limitations of Warranty

- TO THE EXTENT ALLOWED BY LOCAL LAW, NEITHER HP NOR ITS THIRD PARTY SUPPLIERS MAKE ANY OTHER WARRANTY OR CONDITION OF ANY KIND, WHETHER EXPRESS OR IMPLIED, WITH RESPECT TO THE HP PRODUCTS, AND SPECIFICALLY DISCLAIM THE IMPLIED WARRANTIES OR CONDITIONS OF MERCHANTABILITY, SATISFACTORY QUALITY, AND FITNESS FOR A PARTICULAR PURPOSE.

### C. Limitations of Liability

- To the extent allowed by local law, the remedies provided in this Warranty Statement are the customer's sole and exclusive remedies.
- TO THE EXTENT ALLOWED BY LOCAL LAW, EXCEPT FOR THE OBLIGATIONS SPECIFICALLY SET FORTH IN THIS WARRANTY STATEMENT, IN NO EVENT SHALL HP OR ITS THIRD PARTY SUPPLIERS BE LIABLE FOR DIRECT, INDIRECT, SPECIAL, INCIDENTAL, OR CONSEQUENTIAL DAMAGES, WHETHER BASED ON CONTRACT, TORT, OR ANY OTHER LEGAL THEORY AND WHETHER ADVISED OF THE POSSIBILITY OF SUCH DAMAGES.

### D. Local Law

- This Warranty Statement gives the customer specific legal rights. The customer may also have other rights which vary from state to state in the United States, from province to province in Canada, and from country to country elsewhere in the world.
- To the extent that this Warranty Statement is inconsistent with local law, this Warranty Statement shall be deemed modified to be consistent with such local law. Under such local law, certain disclaimers and limitations of this Warranty Statement may not apply to the customer. For example, some states in the United States, as well as some governments outside the United States (including provinces in Canada), may:
  - Preclude the disclaimers and limitations in this Warranty Statement from limiting the statutory rights of a consumer (e.g., the United Kingdom);
  - Otherwise restrict the ability of a manufacturer to enforce such disclaimers or limitations; or
  - Grant the customer additional warranty rights, specify the duration of implied warranties which the manufacturer cannot disclaim, or not allow limitations on the duration of implied warranties.
- FOR CONSUMER TRANSACTIONS IN AUSTRALIA AND NEW ZEALAND, THE TERMS IN THIS WARRANTY STATEMENT, EXCEPT TO THE EXTENT LAWFULLY PERMITTED, DO NOT EXCLUDE, RESTRICT, OR MODIFY, AND ARE IN ADDITION TO, THE MANDATORY STATUTORY RIGHTS APPLICABLE TO THE SALE OF HP PRODUCTS TO SUCH CUSTOMERS.

## HP Year 2000 Warranty

Subject to all of the terms and limitations of the HP Limited Warranty Statement stated above, HP warrants that this HP Product will be able to accurately process date data (including, but not limited to, calculating, comparing, and sequencing) from, into, and between the twentieth and twenty-first centuries, and the years 1999 and 2000, including leap year calculations, when used in accordance with the Product documentation provided by HP (including any instructions for installing patches or upgrades), provided that all other products (e.g. hardware, software, firmware) used in combination with such HP Product(s) properly exchange date data with it. The duration of the Year 2000 warranty extends through January 31, 2001.



# Index

- A**
  - accessories **vi**, **45**
  - automatic two-sided printing
    - layout panel **9**
- B**
  - background printing **11**, **12**
  - banners
    - choosing paper for **21**, **53**
    - metric sizes **53**
    - minimum margins **54**
    - ordering **46**
    - printing **21**
    - problems **41**
  - best mode **9**, **52**
    - print speed **52**
  - bi-directional cable **vi**
  - black and white printing **10**
  - book binding **23**
  - brightness **10**
  - buttons
    - cancel **7**
    - power **1**, **28**, **38**
    - print **7**
    - resume **1**, **19**, **35**, **38**
    - revert to default **7**
    - save settings **7**
- C**
  - cables
    - ordering **45**
    - parallel **vi**
    - recommended **vi**
    - USB **vi**
  - cancel button **7**
  - capacity, paper tray **vii**
  - cards
    - choosing paper for **53**
    - metric sizes **53**
    - minimum margins **54**
    - printing **14–17**
    - specifications **46**
  - change printers **12**
  - change the order of print jobs **12**
  - cleaning
    - print cartridges **29**
    - printer **3**
    - color panel **10**
    - color resolution **52**
    - color tone **10**
    - colorSync **10**
    - computer, controlling from **1**, **4**
    - connections
      - USB **4**
    - customer support **42**
  - D**
    - default printer **4**
    - delete a print job **12**
    - desktop printing **5**
    - dimensions **52**
    - door, rear access **35**, **38**
    - draft mode **9**, **52**
      - print speed **52**
    - drivers, *see printer software*
    - duty cycle **52**
  - E**
    - energy usage **52**
    - envelopes
      - choosing **53**
      - metric sizes **53**
      - minimum margins **54**
      - printing single **15**
      - printing stack **16**
    - environment, operating **52**
  - F**
    - fax printing, problems **36**
    - FCC statement **55**
    - features **vii**
    - foreground printing **11**
  - G**
    - general panel **8**
    - getting help, *See help*
    - grayscale **10**
    - greeting cards
      - printing **14–17**
  - H**
    - help
      - electronic **vii**
      - HP customer care **43**
      - information sources **vii**
      - on the printer **vii**
      - technical support **42**
      - web sites and user forums **vii**
    - high res photo mode **9**
    - HP color matching **10**
    - HP customer care **43**
  - I**
    - I/O interface **52**
    - icons
      - printer status **5**
    - IN tray **2**
      - capacity of **53**
    - index cards
      - printing **17**
    - ink
      - density **40**
      - ordering **45**
      - streaking **29**
    - ink cartridges
      - cleaning **30**
      - ordering **45**
    - installing
      - printer software **33**, **34**
      - problems **33**, **34**
      - software **33**
    - iron-on transfers
      - ordering **46**
      - printing **20**
  - J**
    - jams, *see paper jams*
  - L**
    - labels
      - choosing types to use **53**
      - paper jams with **35**
      - printing **18**
    - Layout panel **9**
    - LED indicator statement **55**
    - lights
      - online **1**
      - print cartridge status **1**, **26**, **27**
      - resume **1**





## Index

### M

- maintenance
  - print cartridges 26
  - printer 3
- manual two-sided printing 23
- margins
  - banners 54
  - minimums, by paper type 54
- media size 53
- media weight, recommended 53
- media, *see paper*
- metric paper sizes 53
- modes
  - best 9, 52
  - draft 9, 52
  - high res photo 9
  - normal 9, 52
  - printing speeds 52

### N

- noise
  - printer 3
- noise emissions 53
- normal mode 9, 52
- print speed 52

### O

- online support, web site vii
- operating environment 52
- ordering
  - parts and accessories 47
  - supplies 45
- OUT tray 2, 53

### P

- page orientation 6
- page setup dialog box 6
- paper
  - metric sizes 53
  - minimum margins, by type 54
  - specifications 53
  - supplies 46
  - weight of 53
- paper guides 2
- paper jams, clearing 35, 38
- paper size 6
- paper sizes
  - and minimum margins 54
  - by paper type 53

- paper tray
  - capacity 53
- paper trays
  - capacity vii
  - IN tray 2
  - OUT tray 2
  - positions 2
- paper type/quality panel 9
- parts
  - numbers 45
  - ordering 45
  - supplies 45
- pausing/holding a print job 12
- posters
  - printing 9
- posters, printing 22
- power
  - adapter vi
  - button 52
  - consumption 52
  - cord vi
  - cord, ordering 45
  - light 52
- print
  - at a specific time 12
- print button 7
- print cartridge status 26
- print cartridge status light 52
- print cartridges
  - cleaning 28, 29, 30
  - damage from refilling 32
  - light 27
  - ordering 45
  - part numbers 45
  - problems 27, 28
  - recommended temperatures 28
  - replacement 27
  - status 26
  - status light 1
  - storing 28
  - using 28
- print dialog box 7
- print margins 54
- print modes
  - best 9, 52
  - draft 9, 52
  - high res photo 9
  - normal 9, 52
- print problems 29
- print problems, *see problems*
- print quality vii
  - cleaning print cartridges 29
  - improving 40
  - problems 40
  - using refilled print cartridges 32
- print quality problems 29
- print speed vii
  - best mode 52
  - draft mode 52
  - normal mode 52
  - specifications 52
- print technology 52
- printer
  - accessories vi, 45
  - cable
    - parallel 45
    - USB 45
  - cleaning 3
  - components vi
  - connections 35
  - controlling 1, 4
  - dimensions 52
  - driver updates, *see software updates*
  - drivers, *see printer software*
  - list of parts vi
  - maintenance 3
  - noise 3
  - online help vii
  - package contents vi
  - paper trays 53
  - parts 45
  - recommended cables vi
  - selecting default 4
  - setting up vi
  - software 42
  - software updates 42
  - specifications 52
  - status 5
  - weight 52
- printer software
  - downloading 42
  - problems installing 33



## Index

- updates
- printing
  - banners 21
  - book 23
  - business cards 17
  - cards 14–17
  - envelopes, single 15
  - envelopes, stack 16
  - faxes 36
  - from the desktop 5
  - greeting cards 14–17
  - index cards 17
  - iron-on transfers 20
  - labels 18
  - over a network vi
  - posters 9, 22
  - quality 29, 40
  - stop/restart 12
  - tablet 23
  - transparencies 19
  - two-sided, book 23
  - two-sided, tablet 23
- printing problems 28
- printing problems, *see problems*
- problems
  - banner printing 41
  - blank page came out of printer 36
  - CD, not reading 33
  - fax 36
  - flashing lights 38
  - help 33
  - ink streaks 29
  - installing printer software 34
  - jam 35
  - lights flashing 38
  - no page not came out 35
  - output 39, 40
  - page did not print 35
  - paper jam 35
  - parts of output in wrong place 39
  - parts of output missing 39
  - power light flashing 38
  - print cartridge status light flashing 38
  - print cartridges 28
  - print quality 40
  - printing 35–37
  - resume light flashing 38
  - slow printer 37
  - software installation 34
  - software, not reading 33
  - too much ink 40
  - using refilled print cartridges 32
- Q**
  - quality vii
  - printing 29
  - quick start poster ordering 45
- R**
  - rear access door
    - removing 35, 38
    - replacment parts 45
  - recycle 60
  - regulatory notices 55
  - resolution
    - black 52
    - color 52
    - true type text 52
  - restart printing 12
  - resume button 52
  - resume light 52
  - revert to default button 7
- S**
  - saturation 10
  - save settings button 7
  - scaling 6
  - select panel 25
  - selecting a default printer 4
  - setting up printer vi
  - setup
    - problems 33–34
  - size
    - media 53
    - specifications 53
  - software compatibility 52
  - software, *see printer software*
  - sort the order of print jobs 12
  - specifications 52
  - speed, printing 52
  - status
    - print cartridge status light 1
    - stop printing 12
    - stuck paper, *see paper jams*
    - supplies 45
      - ordering 45
      - paper and other media 46
      - part names and numbers 45
- T**
  - tablet binding 23
  - technical support 42
  - transfers, printing 20
  - transparencies
    - ordering 46
    - printing 19
  - trays
    - envelope slot 15
    - IN 53
    - IN tray 2
    - OUT 53
    - OUT tray 2
  - troubleshooting, *see problems*
  - true type text resolution 52
  - two-sided printing 23
- U**
  - updates for software 42
  - urgent print requests 12
  - USB connection 4
  - user's guide, ordering 45
  - Utility window 29
  - utility window 24, 25, 29, 31
- W**
  - warranty
    - extensions 44
    - statement 56
  - web site vii
  - web sites 33, 37, 45, 47
  - weight
    - paper 53
    - printer 52
    - recommended media 53

# Environmental Statement

Hewlett-Packard continuously improves the design processes of HP DeskJet printers to minimize the negative impact on the office environment and on the communities where printers are manufactured, shipped, and used. Hewlett-Packard has also developed processes to minimize the negative impact of the disposal of the printer at the end of printing life.

## Reduction and Elimination

**Paper Use:** The printer's automatic/manual two-sided printing capability reduces paper usage and the resulting demands on natural resources. This printer is suited for the use of recycled papers according to DIN 19 309.

**Ozone:** Ozone-depleting chemicals such as CFCs have been eliminated from Hewlett-Packard manufacturing processes.

## Recycling

Design for recycling has been incorporated into this printer. The number of materials has been kept to a minimum while ensuring proper functionality and reliability. Dissimilar materials have been designed to separate easily. Fasteners and other connections are easy to locate, access, and remove using common tools. High priority parts have been designed to access quickly for efficient disassembly and repair. Plastic parts have been primarily designed in no more than two colors to enhance recycling options. A few small parts are colored specifically to highlight customer access points.

**Printer Packaging:** The packaging materials for this printer have been selected to provide maximum protection for the least cost possible, while attempting to minimize environmental impact and facilitate recycling. The rugged design of the HP DeskJet printer assists in minimizing both packaging materials and damage rates.

**Plastic parts:** All major plastics and plastic parts are marked according to international standards. All plastic parts used in the printer housing and chassis are technically recyclable and all use a single polymer.

**Product Longevity:** To ensure the longevity of your DeskJet Printer, HP provides the following:

- Extended Warranty - HP SupportPack provides coverage for the HP hardware and product and all HP supplied internal components. HP SupportPack must be purchased by the customer within 30 days of purchase. Contact the nearest HP dealer about this service.
- Spare Parts and Consumables are available for five years after production has stopped.
- Product Take-back - To return this product and ink cartridges to HP at the end of its useful life, call your local HP Sales or Service Office for instructions.

## Energy Consumption

This printer was designed with energy conservation in mind. This printer averages 4 watts in stand-by mode. Not only does this save natural resources, but it also saves money without affecting the high performance of this printer. This product qualifies for the ENERGY STAR Program (U.S. and Japan). ENERGY STAR is a voluntary program established to encourage the development of energy-efficient office products. ENERGY STAR is a US registered service mark of the US EPA. As an ENERGY STAR partner, Hewlett-Packard Company has determined that this product meets ENERGY STAR Guidelines for energy efficiency.



**Energy consumption in off-mode:** When the printer is off, a minimal amount of energy is still being consumed. Energy consumption can be prevented by turning the printer power off, then disconnecting the end of the printer power cord from the electrical source.