

# ADJUSTABLE SPEED DRIVES APPLIED TO LARGE AC INDUCTION MOTOR AND PUMP SYSTEMS

by

**Timothy J. Cookson**

Consultant

E. I. du Pont de Nemours and Company, Inc.

Moncks Corner, South Carolina

**Nicholas G. Lang**

Electrical Engineer

Siemens Energy and Automation

Norwood, Ohio

and

**Edward J. Thornton**

Senior Consultant

E. I. du Pont de Nemours and Company, Inc.

Houston, Texas

---

*Timothy J. (Tim) Cookson is a Consultant in the Electrical Technology Consulting Group of DuPont's Engineering Department, in Moncks Corner, South Carolina. He joined DuPont in 1969 as an Electrical Design Engineer at the Kinston, North Carolina, Textile Fibers Plant. Mr. Cookson has held numerous technical and leadership roles in DuPont throughout his 38 year career. He is currently DuPont's technology leader for motor and drive applications.*

*Mr. Cookson received a B.S. degree (Electrical Engineering, 1969) from Grove City College.*

---

*Nicholas G. (Nick) Lang is an Electrical Engineer with Siemens Energy and Automation, in Norwood, Ohio. He is assigned to the large AC motor factory. Mr. Lang's specialty is induction motor design and troubleshooting. He is currently researching insulation systems in the SE&A Norwood Development Engineering Department.*

*Mr. Lang received his B.S. degree (Electrical Engineering) from the University of Cincinnati.*

---

*Edward J. (Ed) Thornton is a Senior Consultant in the Electrical Technology Consulting Group of DuPont's Engineering Department, in Houston, Texas. His specialty is the design, operation, and maintenance of electric power distribution systems and large motor installations. He has 20 years of consulting experience with DuPont.*

*Mr. Thornton received his B.S. degree (Electrical Engineering, 1978) from Virginia Polytechnic Institute and State University. He is a registered Professional Engineer in the State of Texas.*

---

## ABSTRACT

Adjustable speed drives (ASDs) are commonly used today in conjunction with large alternating current (AC) induction motors to drive pumps. The ASD application can provide many operational

and energy conservation advantages. However, the ASD and motor must be designed as a system to realize the benefits and to avoid the potential pitfalls. This paper will review key motor design considerations and highlight some typical pump applications where ASDs can be employed.

## INTRODUCTION

In today's industrial and commercial world, adjustable speed drives (ASDs), which include alternating current (AC) variable frequency drives (VFDs), have become the accepted method of speed control for pump and other motor driven applications. Most ASD systems consist of three basic components:

1. A rectifier that converts the fixed AC input voltage to direct current (DC) voltage;
2. An inverter that switches the DC voltage to an adjustable frequency AC output voltage; and
3. A controller that directs the rectifier and inverter to produce the desired AC frequency and voltage to meet the needs of the ASD system.

Figure 1 shows a block representation of a typical motor and ASD system.

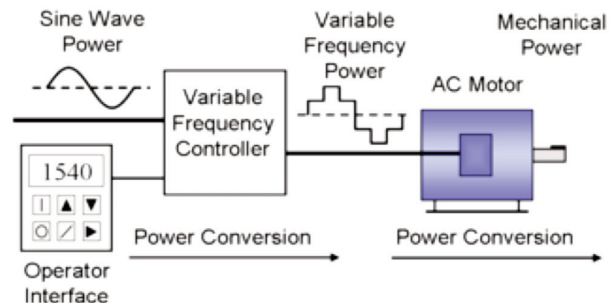

Figure 1. Typical Motor and ASD System.

AC adjustable speed drives operate under the principle that the speed of an AC motor is determined by the frequency of the AC supply and the number of poles in the stator winding in accordance with Equation (1).

$$RPM = \frac{120 \times f}{p} - Slip \quad (1)$$

where:

- RPM = Revolutions per minute  
 f = AC power frequency (Hertz) applied to the motor  
 p = Number of motor poles (an even number)  
 Slip = The difference between rotor speed and the rotating magnetic field in the stator

Synchronous motors have zero slip and therefore operate at synchronous speed. AC induction motors typically have a slip in the range of 1 to 1.5 percent of synchronous speed. Proper application of the ASD requires a properly engineered motor to maximize the versatility and benefits of the adjustable speed capability.

#### Basic Adjustable Speed Drive Types

Adjustable speed drives are differentiated and characterized by their inverters, and can use either current regulating or voltage regulating techniques to switch DC power to AC power. The most prevalent ASDs are classified as:

- Current source inverters and
- Voltage source inverters, principally six-step inverters and pulse width modulated (PWM) inverters.

##### Current Source Inverters

Current source inverters control the amount of current delivered to the motor in addition to controlling voltage and frequency. The unit is a current regulator that can limit the current with a short circuit across its output. These units are often used in single large horsepower motor applications. Their design provides inherent regenerative capabilities. For high inertia application, this drive feeds power back into the AC power system to provide an effective means of decreasing the speed of the connected load.

##### Voltage Source Inverters

The six-step voltage source inverters control only voltage and frequency and operate independently of the motor impedance. They can be used to distribute the drive output to many motors simultaneously. The variable voltage inverter circuit can be designed with current limiting protection on the output and are often known as a “six-step drive.” These drives, prevalent in the early years of ASD application, have been displaced in industry by the PWM drive.

##### Pulse Width Modulated Inverters

PWM drives are the industry drive option of choice. They are available in sizes up to several thousand horsepower and can be paralleled to deliver in excess of 20,000 horsepower. Manufacturers provide these drives in air-cooled or water-cooled packages. These drives will control speed, torque, direction, starting, and stopping of standard asynchronous or synchronous AC motors. Generally, they are available with the world’s most common supply voltages up through the “medium voltage” range of from 2400 to 6600 V. Since the PWM inverter is so commonly applied, it will be the focus drive for this paper. The PWM design differs from the current source and variable voltage types by the use of a diode bridge in the rectifier that provides a constant voltage DC bus. The inverter section uses a pulse width modulated algorithm to produce a near sine wave output current to the motor. Early PWM units were designed with a carrier switching frequency in the 2 kHz range, which sometimes created annoying audible

sounds. The more recent designs can now offer carrier frequencies in the 15 kHz to 20 kHz range by using insulated gate bipolar transistors (IGBTs) in the output circuit. Figure 2 shows the basic components of a PWM adjustable speed drive.

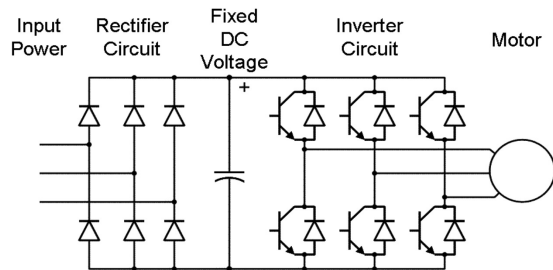

Figure 2. Pulse Width Modulated ASD Components.

The ASD design creates some challenges on the motor side such as harmonics and increased stress on the motor insulation and bearings. These issues must be appropriately addressed in the large AC induction motor design discussions.

#### MOTOR DESIGN CONSIDERATIONS

The process of determining the proper motor design begins with an accurate assessment of the application including specifics such as the load torque requirements, the starting method to be employed, and the environment. Thermal impact on the stator and bearing design due to reduced operating speed and drive harmonics must also be addressed.

##### Load Speed/Torque Requirements

The fundamental task of selecting a motor for a variable speed application is to match the speed-torque capability of the motor to the speed-torque requirement of the load. The continuous torque capability curve of the motor must be above the speed-torque demand curve of the driven equipment throughout the operating range. Also, the intermittent torque capability of the motor must be sufficient to start and accelerate the driven equipment, including driving the load during momentary overload conditions. The best method to assure a successful application is to secure a speed-torque curve from the driven equipment manufacturer. In variable torque applications such as pumps, the load torque varies exponentially by the speed allowing for motor operation near breakdown (peak) torque without thermal concerns. The ability to accelerate the load easily still hinges on the load characteristics and starting method of choice.

##### Starting Methods

From an idle condition, ASD systems have several methods by which they may accelerate the load to full speed. Where possible, utilizing the ASD during starting will reduce the peak power consumption of the motor by as much 80 percent (thus reducing utility cost significantly). Some applications also require the capability to be started “across the line,” thus bypassing the drive. However, it should be taken into consideration that designing a system to be started exclusively through the drive may offer higher overall efficiency as well. Drive starting allows an induction motor to start with much less effort, where torque throughout acceleration would be approximately equivalent to breakdown torque and would provide greatly reduced rotor bar and stator currents. This reduction, in and of itself, provides extended rotor and stator life as seen by the number of starts, and may extend safe locked rotor time. In this sense, starting with an ASD is “preferred.”

To provide a point of reference, alternative methods, including solid-state soft starters, autotransformer starting, and other forms of reduced voltage starting, lower motor output torque and extend acceleration time. This would, in many applications, shorten rotor and

stator life due to thermal and mechanical stress. When defining system parameters, one must account for the maximum expected torque and current demands to properly size the motor and drive. An overload condition considered in the late design stages may have dramatic effects on system cost (i.e., larger/more robust motor/drive).

#### *Service Duty and Environment Concerns*

Knowledge of the system duty cycle is required in order to determine the possible thermal derating for the motor design. In addition, the environment where the motor is to be installed must be understood. If the ambient temperature surrounding the motor exceeds 104°F (40°C), motor derating may be required. Also, any applications requiring hazardous location certification would have to be considered up front to ensure the system is free or arcing/sparking components and that all surface temperatures remain below the ignition temperature of the hazard in question.

#### *Stator Winding—Effects of the Drive on the Motor*

Noise sent through the motor's feeder conductors by an unfiltered drive can shorten motor life and reduce overall system efficiency. It is best to determine specifically which type of drive will be used before proceeding to design the rest of the system. The many differences, including different carrier frequencies and amplitude of maximum voltage peaks, can impact the design of the motor. The spikes seen at the motor terminals can cause as much as an additional 10 percent heating (somewhat due to  $I^2R$ , increased iron losses at higher frequencies, and somewhat due to the loading effect from negative phase sequence currents). Key indices of stator life include thermal endurance, voltage endurance, and long-term surge withstand. While a 10 percent increase in temperature can seem negligible on Class B temperature rise systems designed with Class F temperature insulation, the effect of high-amplitude, high-frequency harmonics is not insignificant. The damage that continually occurs and compounds can be monitored with online partial discharge equipment. The expected lifetime for a stator winding can be expressed by the number of pulses seen from a power system including switchgear or noisy drives. This includes noise transmitted through a facility's power lines from operating noisy drives and components in other applications nearby.

#### *Shaft Design and Bearing Impact*

Another adverse effect of an unfiltered drive is motor shaft currents. In this case the distorted magnetic field induces current in the rotor shaft, which would travel through the bearing if the shaft is not properly grounded. When this is the case, a grounding brush is required to safely dissipate the energy from the shaft without risking damage to the bearings or bearing journals. Left unmitigated this phenomenon can severely pit bearings to the point that fluting, excessive noise, and eventual failure occur. Insulating the motor bearings is a solution that tends to shift the problem elsewhere as the shaft current looks for another path to ground. If an attached piece of equipment, such as a pump, provides this path, it often experiences a bearing failure of its own. Figure 3 shows bearing damage as a result of induced motor shaft currents.



Figure 3. Damaged Bearing from ASD Induced Shaft Currents.

This same level of electrical noise will also be evident in vibration levels (some of which would be torsional vibration, not detectable by conventional means) and audible noise levels. Depending on the motor design, the effect of this type of electrically induced vibration may be severe. It has been known to be capable of causing the shaft to shear and causing other mechanical catastrophic failures. Standards organizations such as the International Electrotechnical Commission (IEC) often apply generic levels for vibration and noise limits. Standards from the US market including the National Electrical Manufacturers Association (NEMA) and various Institute of Electrical and Electronic Engineers (IEEE) specifications typically omit this information as it becomes too specific for the particular system for which the motor and drive are being designed.

#### *Thermal Capacity Concerns*

Cooling is a significant design concern when motors are used in applications requiring wide speed control ranges. In applications requiring constant torque over a speed range of no more than four to one, most motor manufacturers design a motor with sufficient thermal capacity to dissipate the heat generated by the motor current. For wider speed turndown ratios, additional ventilation may be required to satisfy the motor's cooling requirements. In addition, the harmonic components of the voltage supplied by the ASD cause additional heating both in the stator iron by inducing eddy currents and in the windings by causing harmonic currents to flow together with the fundamental current. The effect of this additional heating due to harmonics could consume the motor's thermal capacity margin to handle overload situations.

### MOTOR PERFORMANCE CHARACTERISTICS

Motor performance is typically expressed in terms of torque versus speed, current versus speed, efficiency, and power factor. Acceleration time is computed directly from accelerating torque (motor torque minus load torque) and total inertia (this is the rotational inertia of the motor's rotor as well as the rotational inertia of the load). When starting via the ASD, the motor torque output may remain near the breakdown level, thus providing very short acceleration times for the motor.

As can be seen from Figure 4 and Figure 5, applying oversized or overrated motors to lower load conditions can result in higher operating costs than would otherwise be incurred. In that case the benefits of an oversized motor would not be realized. Arbitrarily sizing for twice the rated load for example, may increase the full load amps nearly 5 percent. A normal method to increase motor torque throughout the speed range would be to strengthen the stator winding (typically increasing starting current) or by changing the resistivity (as in fabricated squirrel cages) or geometry of the rotor bars (as in diecast squirrel cages). Typically a change to the rotor will result in lower starting current with higher torque, but one sacrifices efficiency (due to increased rotor  $I^2R$  losses). This may and in many cases does force a design selection of a larger motor or forces the use of additional active material (electrical steel and copper). This adverse thermal effect of increased rotor resistance can be avoided by the use of variable rotor resistance (as found in wound rotor/slip-ring induction motors). The rotor circuit would be connected in series with a rheostat. However this has its own drawbacks in terms of mean time between failures, as the rotor winding, slip-ring arrangement, and rheostat are all more prone to failure independently than a standard squirrel cage motor design. For machinery requiring frequent starting and stopping, as in typical turbopump applications, starting a squirrel cage induction motor exclusively by means of ASD drastically reduces demands on the motor. However one must take care to ensure that the torsional vibrations caused by unfiltered drives discussed earlier are avoided.

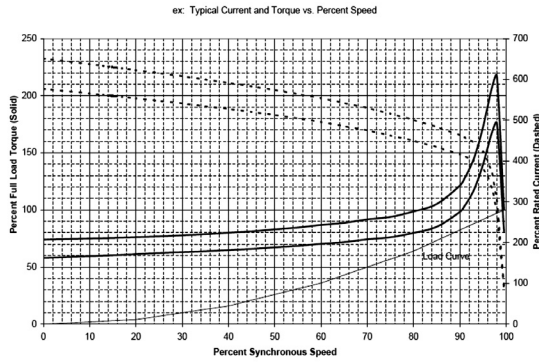

Figure 4. Induction Motor Speed/Torque with Typical Pump Load Curve Torque.

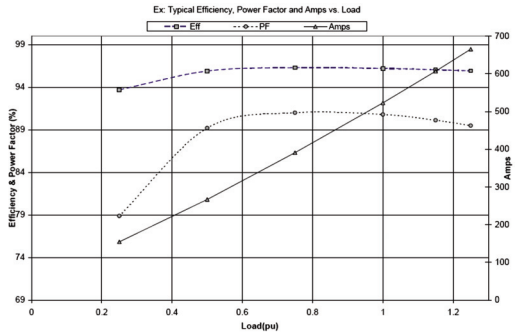

Figure 5. Typical Induction Motor Efficiency, Power Factor and Current Versus Load.

## LARGE ASDs—LOW VOLTAGE VERSUS MEDIUM VOLTAGE COST ISSUES

Historically, the task for low voltage (LV) ASD (up to 690 V AC) users has been relatively straightforward; choose one supplier from many in the market based on a number of criteria including price, reliability, functionality, and communications. However, for a drive control solution for larger industrial loads, the situation is not so clear-cut. Until quite recently, most engineers faced with a high-power application would choose a LV drive system working at very high levels of current.

The alternative of a medium voltage (MV) ASD (2300, 4160, or 6600 V AC) was not very attractive due to high purchase cost, physical size, requirement for custom engineering and high installation costs. Recently the MV drive has shed some of this image and offers a viable alternative to LV drives in the higher power sector, especially where installations are evaluated across their life cycle, rather than based principally on the initial drive cost.

There are a number of reasons for heightened levels of interest in MV drives:

- **Increased selection**—Most major manufacturers now have an MV product;
- **Advances in power semiconductor switches**—New devices offer improved packaging, increased reliability, and reduced overall drive cost; and
- **Standardization**—In the past most MV drives were highly engineered products with lead times of six months or more. Today, greater levels of standardization are substantially reducing delivery times for most standard MV drives.

The emergence of MV drives and their greater acceptance, generally, should not imply that the solution to every high-power application is an MV drive. No two applications are the same. In applications where there is more than one possible solution (LV versus MV), the most cost-effective strategy is to conduct an analysis of the benefits of each system.

In many cases comparisons are unnecessary since the LV versus MV decision simply is a question of the amount of power available in the distribution network at each voltage. In applications where adequate power is assured at more than voltage rating, the choice of drive generally comes down to life-cycle cost and user acceptance.

MV ASDs are not inexpensive. Typically, the cost of a LV ASD is 50 to 75 percent of the initial cost of a MV ASD. However, initial ASD price is only part of the total solution. Cable cost can be a considerable “hidden project cost” and must be considered as part of the LV versus MV ASD evaluation. Cable size and cost vary with the level of current they conduct. The higher the current, the larger the cable, the greater its cost. For LV drives at high power applications, cable and installation costs will be high. Moreover, with LV systems, a transformer is always required. The wiring between the transformer and drive increases the overall cost of wiring. In addition, LV installations require expensive shielded electromagnetic compatibility (EMC) cable. The contrasting expense for MV systems is much less, due largely to the lower current their cables carry, and the fact that they do not need to employ EMC shielded cables.

The example below demonstrates that the cable cost difference between the 480 V and the 4160 V ASD solutions grow significantly as motor current increases. Moreover, the distance between the source, the ASD and the motor greatly impacts cable cost, especially at high power applications. The cost differences can be considerable. Refer to Table 1 for examples of typical wiring costs.

Table 1. Typical Wiring Costs (Cable Tray and Installation Costs Not Included).

	450 HP		1000 HP	
	480 Volts	4160 Volts	480 Volts	4160 Volts
<b>Voltage</b>	480 Volts	4160 Volts	480 Volts	4160 Volts
<b>Load Current</b>	500 Amps	61 Amps	1200 Amps	140 Amps
<b>Cable Size</b>	750 MCM	#6	4 x 1000MCM	#1
<b>Diameter</b>	3.5"	1.17"	4 x 3.5"	1.53"
<b>\$/100 feet</b>	\$3,000	\$400	\$12,000	\$700

Overall efficiencies of either the LV or MV system (transformer through the motor) are comparable and approximately 91 percent. Should drive or motor filtering be required or nonpremium efficient motors be used, then this value will be lower.

In many instances the issue of operational acceptance of a MV ASD installation must be addressed. Many plant maintenance engineers and mechanics are comfortable with LV ASD applications. Concerns exist regarding newer medium voltage applications, which they may see as very complex solutions running at uncomfortable voltage levels that are almost always installed, commissioned, and maintained by the drive supplier.

Certainly, custom engineered MV ASD products of the past were unwieldy and required highly specialized attention, which was usually above and beyond that available from internal plant personnel. The move to more modular MV ASD systems should make their acceptance more widespread and their application better understood in the same way as LV ASD systems.

## ASD RELIABILITY CONSIDERATIONS

The addition of ASDs into industry processes in the early years of ASD technology (early 1970s) caused well-founded concern in manufacturing sector leadership. The improved capability and flexibility that the ASD brought to their processes had to be weighed against the likely downside of reliability compromises. Drives designed prior to the commercialization of the integrated circuit had extremely high component counts. The resultant reliability issues caused by the high number of solid-state devices along with associated issues of component attachment to circuit boards were compounded by a technology still in its infancy. In

addition, many manufacturers released their fledgling drive products to the marketplace with later “field modifications”—an accepted practice much the same as software manufacturers do today with version updates. For process industries where equipment could not be idled, this practice provided many challenges.

In comparison, today’s ASDs are robust and reliable. Component count is extremely low due to the mushrooming development of microprocessors. New designs of power semiconductors are introduced yearly. These new power semiconductors handle power levels in packages that would have been considered impossible 10 years ago. Consequently, the physical size of ASDs has continued to shrink even as power ratings have increased. ASDs continue to be developed that are increasingly intelligent. ASDs monitor their own health as well as the health of the system into which they are integrated. In many cases, the ASDs will mitigate problems before any resultant issues are introduced into the process they are driving. Diagnostic capability of the drives also has grown steadily. ASD troubleshooting is now a process of interrogating the diagnostics and module change out. As ASD technology has evolved, maintenance is performed increasingly at lower skill levels.

Many manufacturers audit the reliability of their equipment and respond to weaknesses in design either in upgrades to existing designs (albeit at a much reduced activity level from the broad “field modification” approach) or in later releases of new equipment versions. Mean time between failure (MTBF) is a much discussed metric in the drive industry. Evaluation of this metric by the ASD manufacturers, however, is dependent upon the collection of customer performance data. One would have to believe that this information is not always communicated to the manufacturer perfectly or in some cases at all. It is reasonable to conclude that the failure data the manufacturers have collected and evaluated leads to a metric that lies somewhere between MTBF and mean time between repair (MTBR).

Depending upon which of the leading ASD manufacturers are polled, MTBF data for their equipment is presented as overall performance of the ASD proper or MTBF of modules within the ASD. Certainly, if the interaction of the modules within an ASD is ignored as a potential reliability contributor, MTBF should be determined by the individual module with the lowest MTBF. Typical MTBF numbers made available from leading manufacturers for their state-of-the-art releases generally indicate that their ASDs have an MTBF of 200,000 hours or approximately 23 years. Whenever MTBF is evaluated, it is always instructive to understand exactly what should be inferred from the number. Consider the reliability function (R) illustrated in Equation (2):

$$R = e^{-t/l} \quad (2)$$

where:

- R = Reliability function or percent probability the ASD will run for t
- t = Run time
- l = Failure rate or 1/MTBF

From the MTBF data currently available from ASD manufacturers, the following reliability function can be plotted as shown in Figure 6.

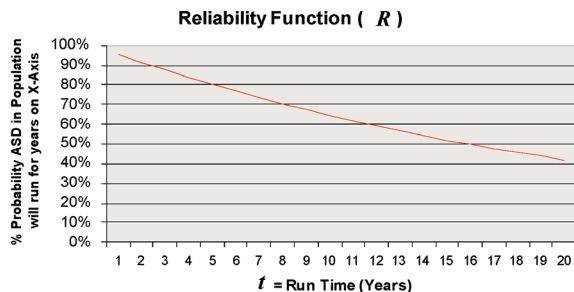

Figure 6. ASD Reliability Function Plot.

The plot therefore shows that with a 23 year MTBF evaluation of the ASD by the manufacturer, the user should expect a probability of run time as indicated on the y-axis. For example, the ASD would have approximately 40 percent probability of survival through its twentieth year.

Also to be considered are the “interactions” that take place between the ASD and its environment or the system into which it is integrated. These factors will impact the overall reliability of the ASD installation. These characteristics are not all inclusive but they are universal. For the purposes here, processes that are continuous or ones that have no production lag storage are assumed, as opposed to batch type manufacturing processes. It is assumed, also, that there is a high degree of instrumentation and interlocking. The impact of a process disruption (reliability incident) could have serious safety implications including run away reactions and environmental releases. Downtime for any production unit could result in costly equipment repairs and extensive restart requirements. Equipment damage may result from overheating, interference interlock failures, insulation breakdown, and other system interactions. Figure 7 illustrates how an ASD interacts with its environment.

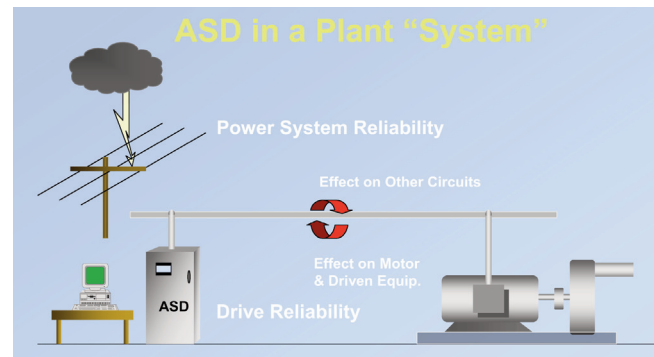

Figure 7. Interaction of ASD System with Surrounding Environment.

The ASD is at the mercy of the power distribution system quality and, in turn, can impact the power distribution through harmonics insertion or notching. The output of the drive can impact the motor with harmonics, voltage traveling waves, or misoperation. The output of the ASD can also couple into other cables or into the grounding system and disrupt operation of other devices particularly low level communication and interlocking signals.

System reliability issues can be mitigated by a number of methods. In depth discussion of these is beyond the scope of this paper, however, these methods include:

- Parallel AC power line supply
- Input power ride through (electronic, capacitor bank, battery bank, flywheel, etc.)
- Hot standby ASD installation
- Master-slave ASD installation
- Parallel pumping arrangement
- Harmonic filtering

## PUMP APPLICATIONS AND OPPORTUNITIES

Pumping systems account for nearly 20 percent of the world’s energy used by electric motors and 25 percent to 50 percent of the total electrical energy usage in many industrial facilities. Significant opportunities exist to reduce pumping system energy consumption through smart design, retrofitting (approximately 20 times more pumps in service than are supplied new every year), and operating practices. In particular, the many pumping applications with variable-duty requirements offer great potential for savings. The savings often go well beyond energy, and may include improved performance, improved reliability, and reduced life-cycle costs.

In a recent evaluation of nearly 1700 pumps at 20 process plants, a large chemical company discovered that:

- Average pumping efficiency was below 40 percent
- 10 percent of pumps were running below 10 percent efficiency
- The major factors affecting the efficiency of these pumping systems were:
  - Throttled valves
  - Oversized pumps
- Seal leakage caused highest downtime and cost

This illustrates the all too common state of current industrial pumping systems in which flow control that uses either:

- Bypass lines,
- Throttling valves, or
- Pump speed adjustments,

frequently is required for the system to meet actual process requirements. Of these three methods, pump speed control is the most efficient. When a pump's speed is reduced, less energy is imparted to the fluid and less energy needs to be throttled or bypassed.

Pump speed can be controlled by a number of means. Currently the most popular speed control method is the ASD, with pulse-width modulated voltage-source drives being the most broadly utilized. In fact, the PWM drives that produce variable-frequency variable-voltage waveforms to control motor speed and torque have practically replaced other technological solutions such as mechanical and hydraulic drives, as well as direct-current (DC) motors and drives.

Additionally, the adjustment of the pump motor speed can lead to better process control, less wear in the mechanical equipment, less acoustical noise, and significant energy savings.

#### Single Pump Application

Centrifugal pumps obey the pump affinity law:

$$BHP_2 = BHP_1 \cdot \left( \frac{N_2}{N_1} \right)^3 \quad (3)$$

where:

BHP = Horsepower  
N = Pump impeller speed

Simply stated, input power required by a centrifugal pump is proportional to its impeller speed cubed.

While a valve can be used to control process flow, adjustment of impeller speed can also be used. Although both techniques meet the desired objective of required flow, the consumed energy is significantly higher when valve throttle control is used. If there is a system head associated with providing a lift to the fluid in the pumping system, the pumps must overcome the corresponding static pressure. In these pumping systems the mechanical energy is used to overcome the friction in the pipes, plus the mechanical work associated with lifting the fluid against the gravity. If the percentage of the power associated with overcoming the pipe friction is relevant, energy savings can still be achieved although typically less than in systems without static pressure head (closed circulation systems).

The overall efficiency of the pumping system depends on the efficiency of the different components of the system. For the same output flow, an inefficient system can absorb significantly more power than that absorbed by the optimized system, thus the importance of an integrated motor system design is essential.

#### Staged Pumping Applications

In many pumping applications several pumps are used in parallel to produce the required flow. By operating all pumps at reduced speed rather than cycling the pumps on/off according to the demand, significant energy savings can be reached. For example, in a low static head two-pump system, with independent piping circuits, operating both pumps at 50 percent of the rated flow requires approximately 25 percent of the power required for a single pump operating at 100 percent. Other advantages are that pumps stay warm (no condensation in the windings), and seals stay wet and alive. This operating strategy also reduces high-shock starts on the system. Also, it is possible to control the "water-hammer" effect, which degrades the pipes, by controlled acceleration/deceleration using ASDs. In a sense, operating shifts can be considered as "batches." If production only occurs on two out of three shifts (or only on weekdays), but pumps run constantly, there is a case for potential savings.

#### ASD TECHNOLOGY DIRECTION

Most advances in ASDs since their inception in the late 1950s can be attributed to advances in power electronics. In particular, the switching device, its switching algorithms, and circuit power switching topologies have drastically changed and for the most part improved over the past 60 years. A 1000 hp drive that consumed 250 ft<sup>3</sup> 10 years ago now consumes less than a third of that volume.

The switches that control the flow of power in an ASD have migrated from the silicon controlled rectifier (SCR) to the transistor and now the IGBT. As each new device has been implemented, it has had the ability to support higher voltages, currents, and therefore power while getting smaller in size. This size decrease is directly related to the materials that make up the switch. New materials such as diamonds are being evaluated to produce the next ASD switch.

New switching algorithms are constantly being developed that allow for reduced losses in the switch and therefore a more efficient drive. One example that is getting increased attention is "pulse smoothing" or "rounding," which prevents turn-on overshoots. Preventing these overshoots mitigates switch losses each time the switch is turned on, which is often greater than 1000 times per second.

Switching topologies continue to be developed though recent developments have been slow in implementation. The main reason for hesitant acceptance is the unique and often complex application of a given topology. An example is the resonant switch inverter that requires special tuning of the drive for different length motor cables.

ASD technology direction will continue to be driven by new switching devices, new switching algorithms, and new circuit power switching topologies. Advancements in each are to minimize losses within the ASD and reduce its physical footprint at the same time. As the last 10 years have seen a 1000 hp ASD shrink by two-thirds, the next 10 years will probably yield the same.

#### CONCLUSION

System design of an effective ASD/motor/pump installation should include an analysis of each component's characteristics to realize the benefits of speed control and energy savings. The motor's insulation and cooling system design must accommodate the unique features offered by ASD technology. Pumping applications with variable duty offer a potential for energy savings, improved performance, and reduced life-cycle costs.