

Sheet-Metal Design Using SolidWorks

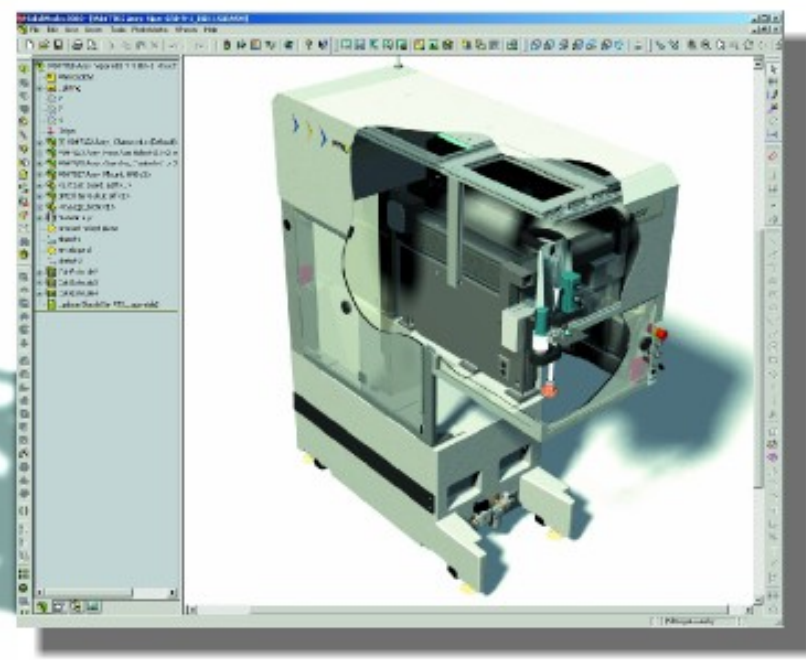

By
EGS India

Sheet Metal Capability

- Sheet Metal – Flexible Working Environment
- Blank Development
- Controlling Parameters
- Forming Tool
- Sheet Metal Design Tools
- Sheet Metal Assembly
- Drawing Creation

- Sheet metal models can be designed in following methods:
 - Design sheet metal from flatten state
 - Design sheet metal from solid
 - Design sheet metal from surface
- Copy and Paste feature between multiple documents
- Drag and Drop facility
- Snap to place, smart mate technology
- Integration with standard Microsoft software's like MS-word, MS-Excel, Visual Basic,etc

Blank Development

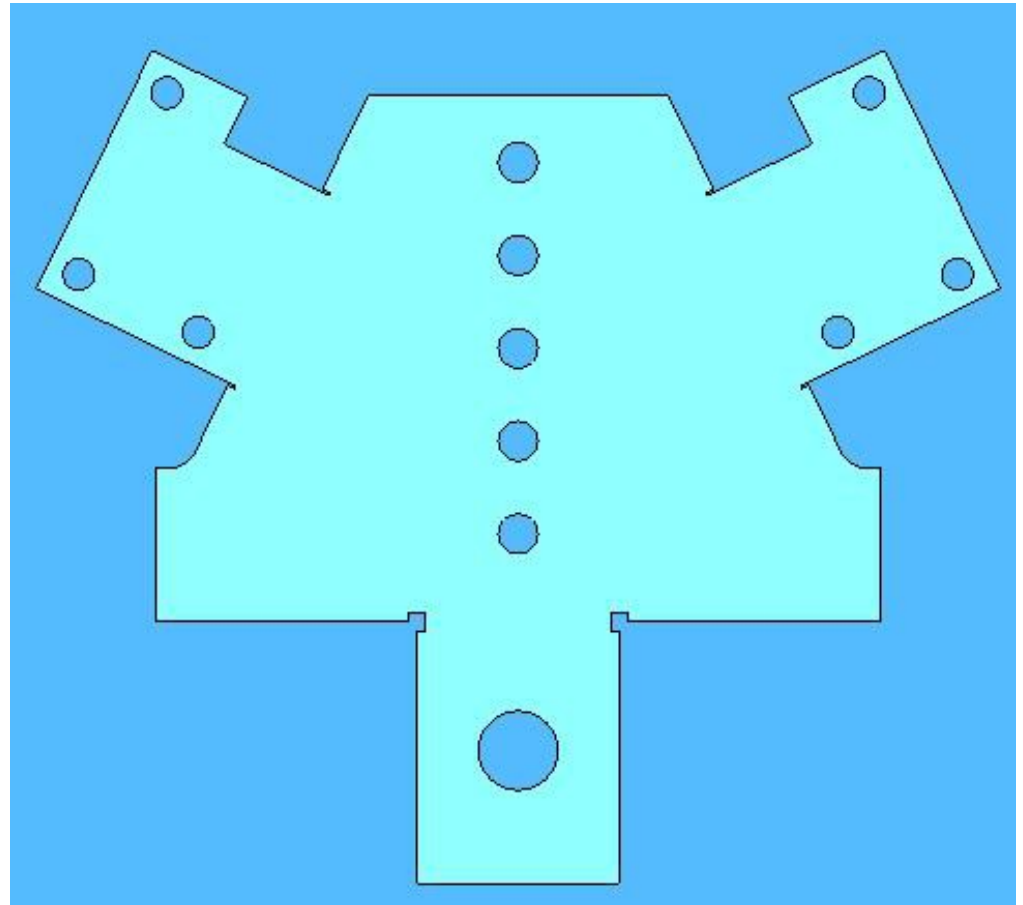
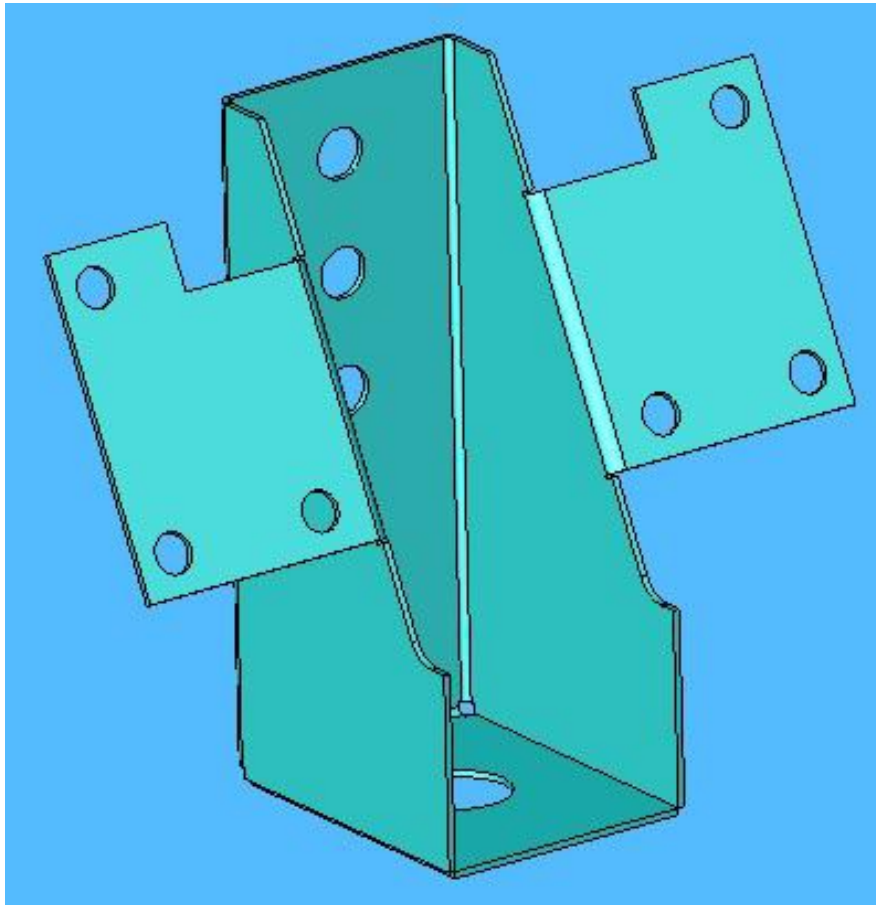

Controlling Parameters

- Sheet metal Bend parameters can be controlled using following options:
 - Bend Table
 - Bend Allowance
 - Bend Deduction
 - K - factor

Bend allowance with a K-Factor is calculated as follows:

$$BA = \pi(R + KT) A / 180$$

where:

BA = bend allowance

R = inside bend radius

K = K-Factor, which is t / T

T = material thickness

t = distance from inside face to neutral sheet

A = bend angle in degrees (the angle through which the material is bent)

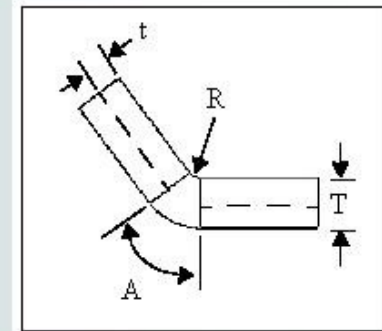

	A	B	C	D	E	F	G	H	I
1	Unit:	Inches							
2	Type:	Bend Allowance							
3	Material:	Soft Copper and Soft Brass							
4	Comment:	Values specified are for 90-degree bends							
5	Radius	Thickness							
6		1/64	1/32	3/64	1/16	5/64	3/32	1/8	5/32
7	1/32	0.058	0.066	0.075	0.083	0.092	0.101	0.118	0.135
8	3/64	0.083	0.091	0.1	0.108	0.117	0.126	0.143	0.16
9	1/16	0.107	0.115	0.124	0.132	0.141	0.15	0.167	0.184
10	3/32	0.156	0.164	0.173	0.181	0.19	0.199	0.216	0.233
11	1/8	0.205	0.213	0.222	0.23	0.239	0.248	0.265	0.282
12	5/32	0.254	0.262	0.271	0.279	0.288	0.297	0.314	0.331
13	3/16	0.303	0.311	0.32	0.328	0.337	0.346	0.363	0.38
14	7/32	0.353	0.361	0.37	0.378	0.387	0.396	0.413	0.43
15	1/4	0.401	0.409	0.418	0.426	0.435	0.444	0.461	0.478
16	9/32	0.45	0.458	0.467	0.475	0.484	0.493	0.51	0.527
17	5/16	0.499	0.507	0.516	0.524	0.533	0.542	0.559	0.576
18	Comment:	Extracted from Machinery Handbook - 26th Edition with permission							
19	Comment:								

Gauge No.	Gauge(Thickness)	Available Bend Radius
3 Gauge	0.2391	.25; .50; .75
4 Gauge	0.2242	.25; .50; .75
5 Gauge	0.2092	.25; .50; .75
6 Gauge	0.1943	.20; .25; .50; .75
7 Gauge	0.1793	.20; .25; .50; .75
8 Gauge	0.1644	.20; .25; .50; .75
9 Gauge	0.1495	.15; .20; .25; .50
10 Gauge	0.1345	.15; .20; .25; .50

Forming Tools

- Forming tools can be created using regular Solid modeling and it can be saved in library. Whenever it needs, just drag and drop from library.

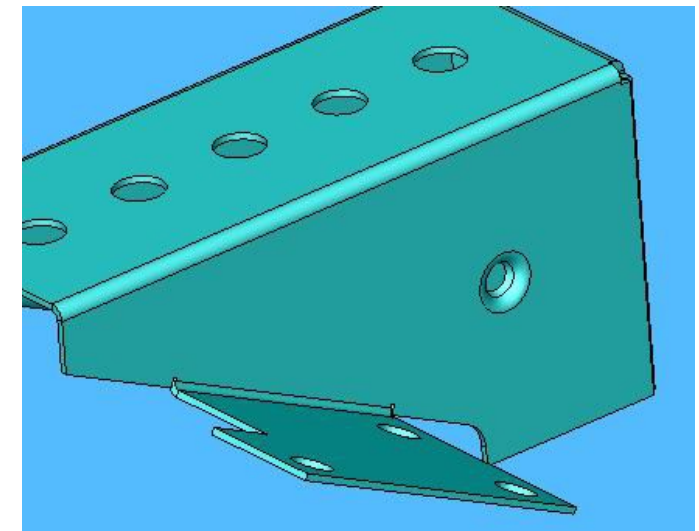
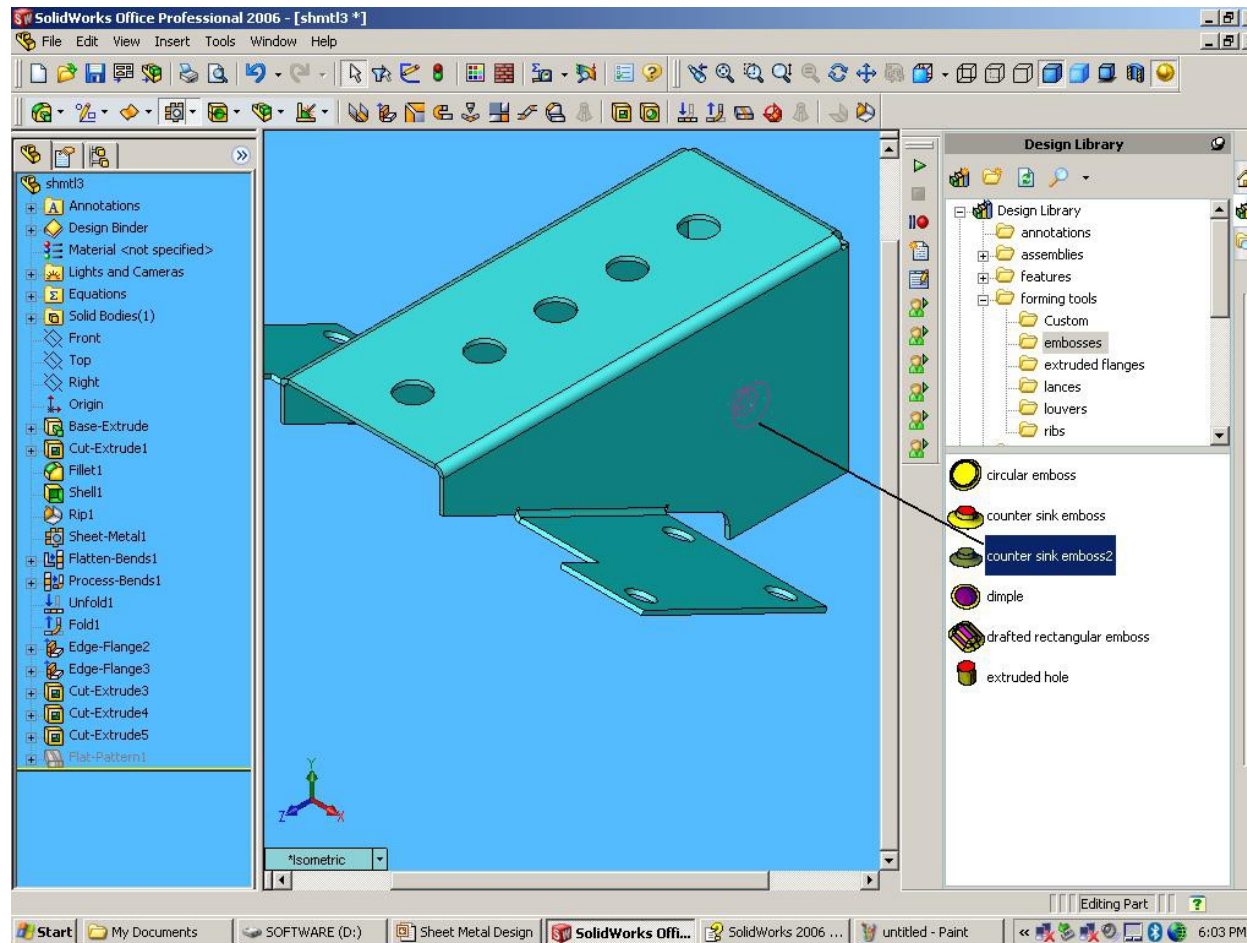

Sheet metal Design Tools

- Base Flange
- Tab
- Edge Flange
- Miter Flange
- Hem
- Sketched Bend
- Closed Corner
- Flatten
- Jog
- Break Corner / Corner Trim
- Lofted Bends
- Fold / Unfold
- Rip
- Insert Bends
- Vent
- Fill Pattern
- Feature Library

Sheet Metal Flange Design – Wide variety of Options

Base Flange Options

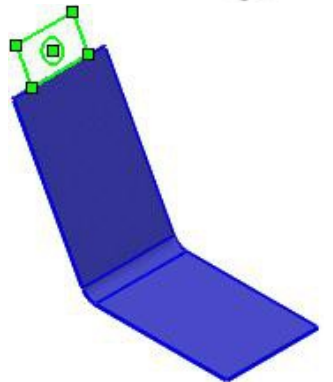
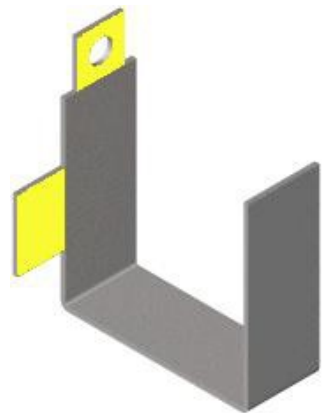

Tab Options

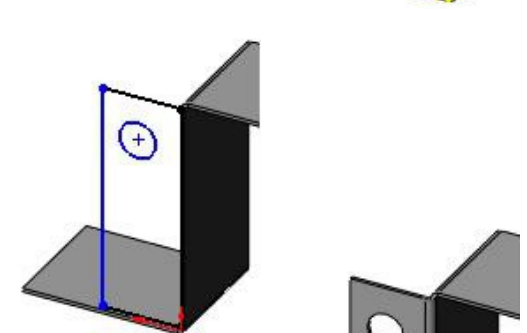
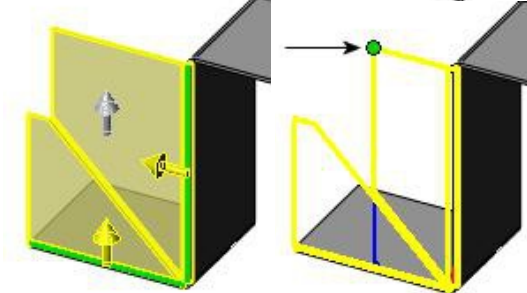
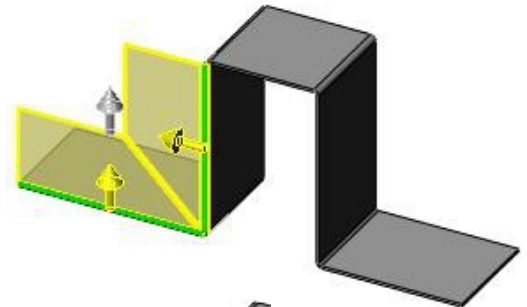

Edge Flange Options

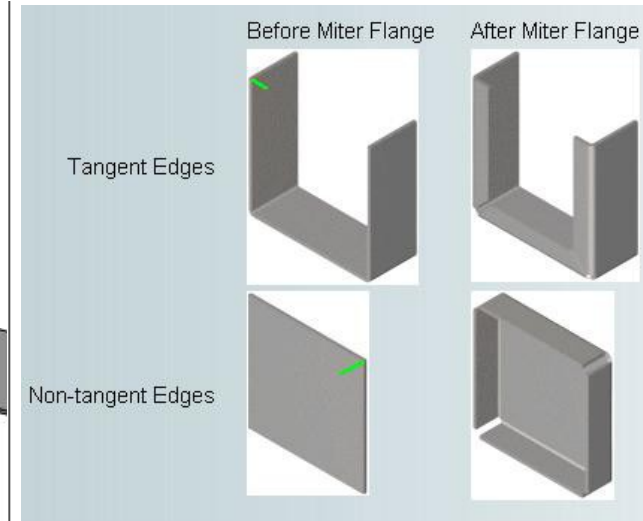

Mitre Flange Edge Options

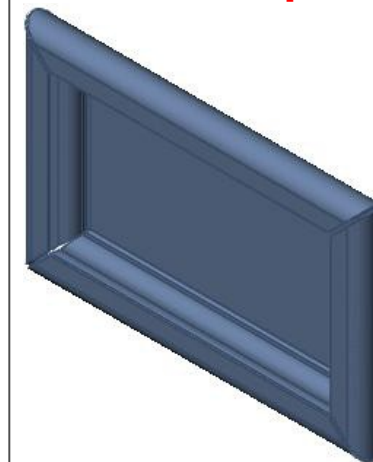

Sheet Metal Flange Design – Bend Options

Mitre Flange

Miter Parameters

Edge <1>

Use default radius

0.7366mm

Flange position:

Trim side bends

Gap distance:

0.25mm

Start/End Offset

d1 0.00mm

d2 0.00mm

Custom Bend Allowance

K-Factor

K 0.5

Mitre Flange Options

This is the preview of an Edge Flange feature. Notice the bend region of the blue preview touches the bend of the L-shaped base flange.

This is the end result without the **Trim side bends** check box.

This is the end result with the **Trim side bends** check box.

Trim side Bend Options

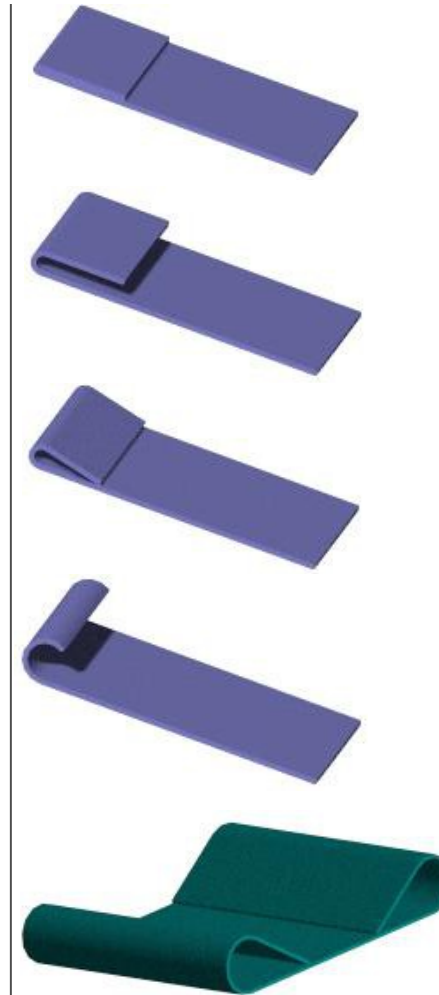

Hem Options



Sketched Bend Options

Sheet Metal Flange Design – Corner Treatment

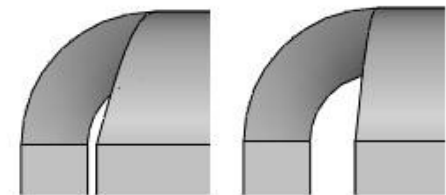
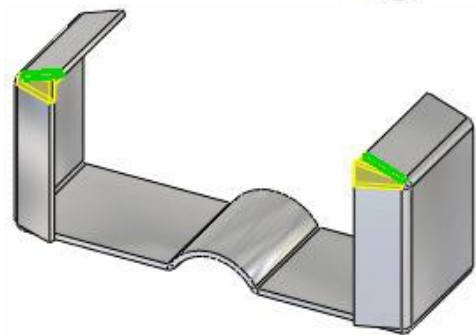
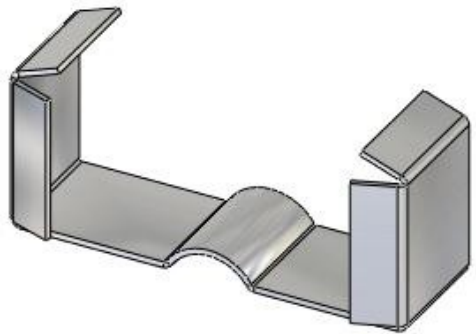

Gap Distance 0.1 Gap Distance 0.05

Closed Corner Options

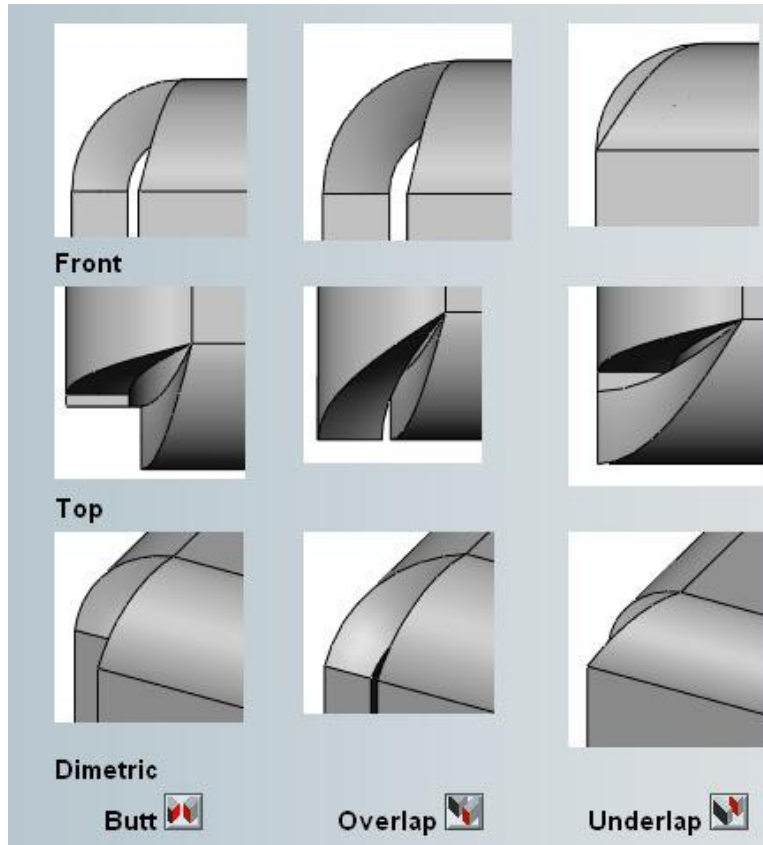

Examples of corner types

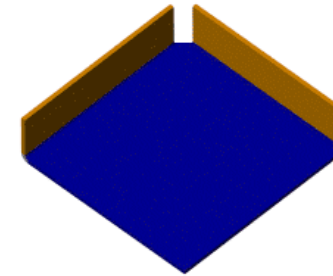

Flattened Model without Corner treatment



Flattened Model with Corner treatment

Corner Treatment

www.egsindia.com

Sheet Metal Flange Design – Trim & Jog Options

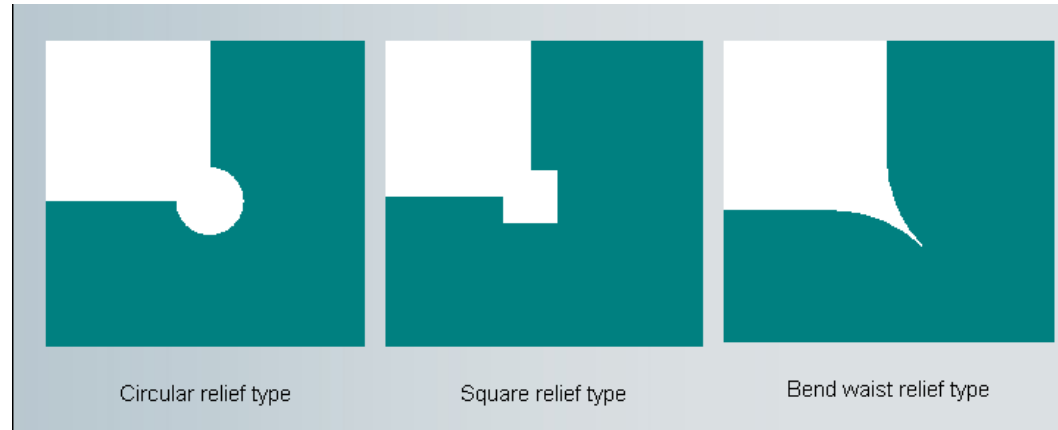

Closed Trim Options

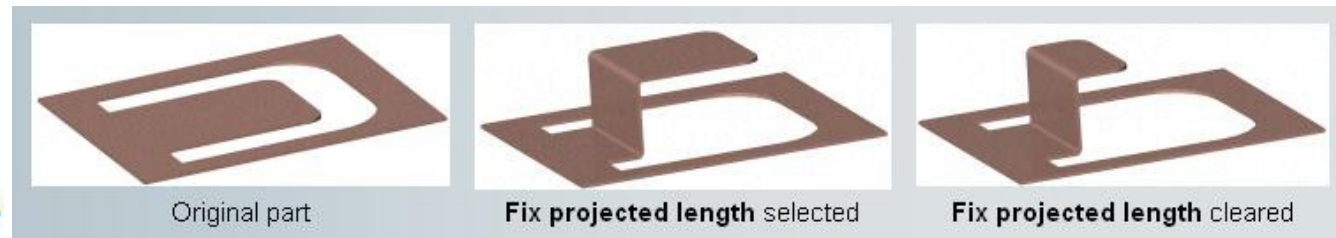
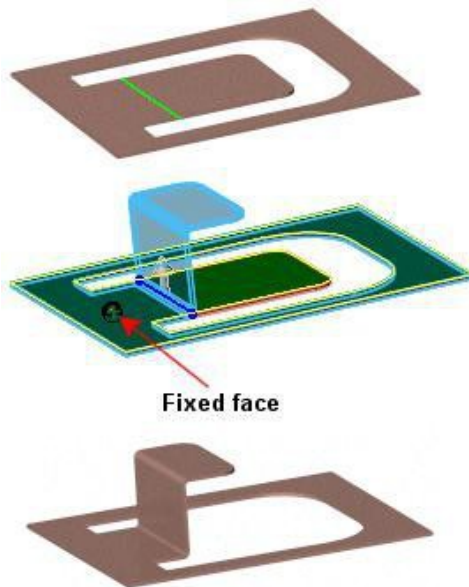

Jog Offset Options

Jog Options

Sheet Metal Flange Design – Corner, Rip and Lofted Bends

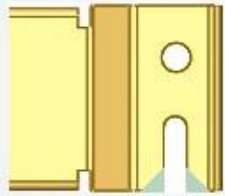

Preview of Break Corner/Corner-Trim

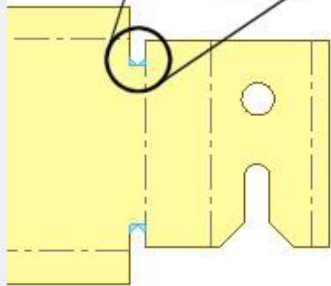
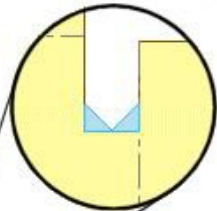

Preview of internal corners



Chamfered Filleted

**Break Corner /
Corner-Trim Options**

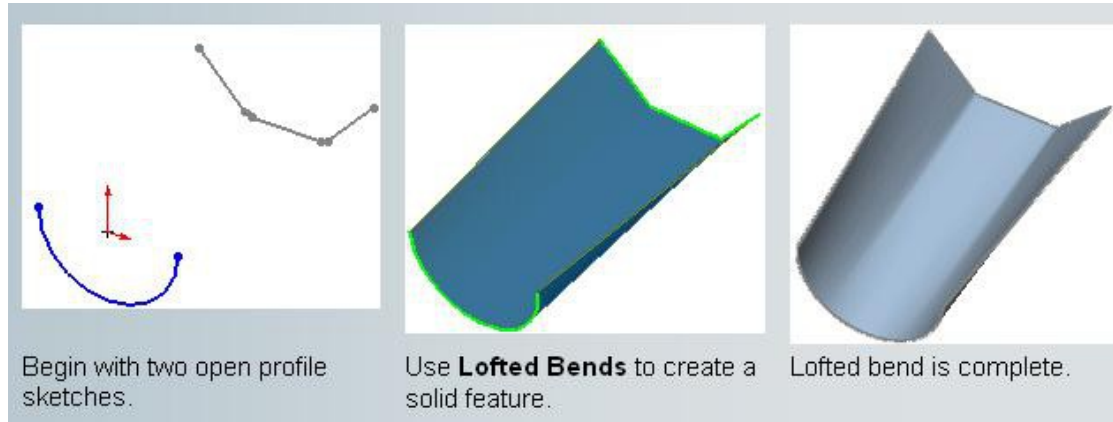

Begin with two open profile sketches.

Use **Lofted Bends** to create a solid feature.

Lofted bend is complete.

Lofted Bend

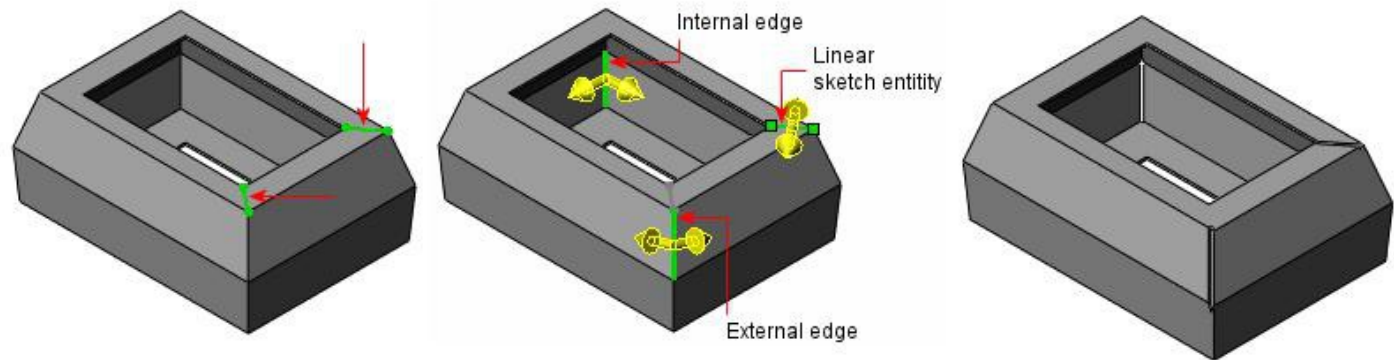

Rip Feature

Sheet Metal Flange Design – Forming Tools & Incorporating Library Features

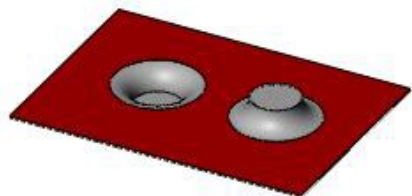

Forming from Design Library

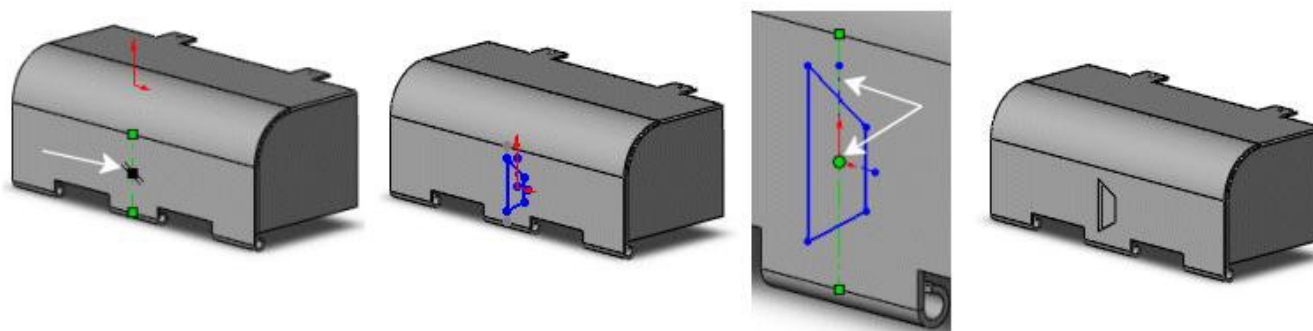

Positioning Forming Tools

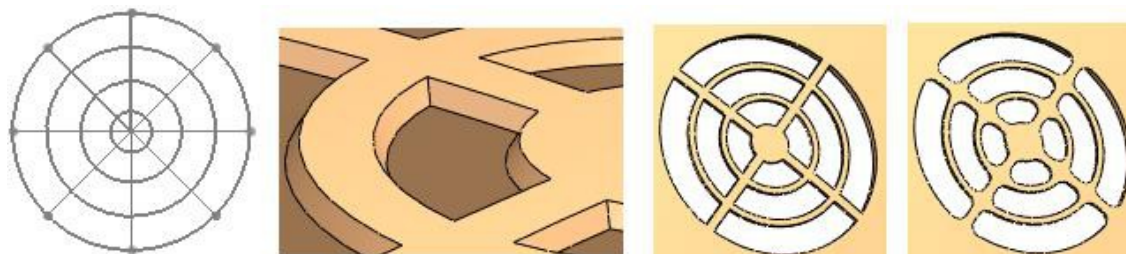

Vent Formation

Sheet Metal Flange Design – Patterning & Surfacing

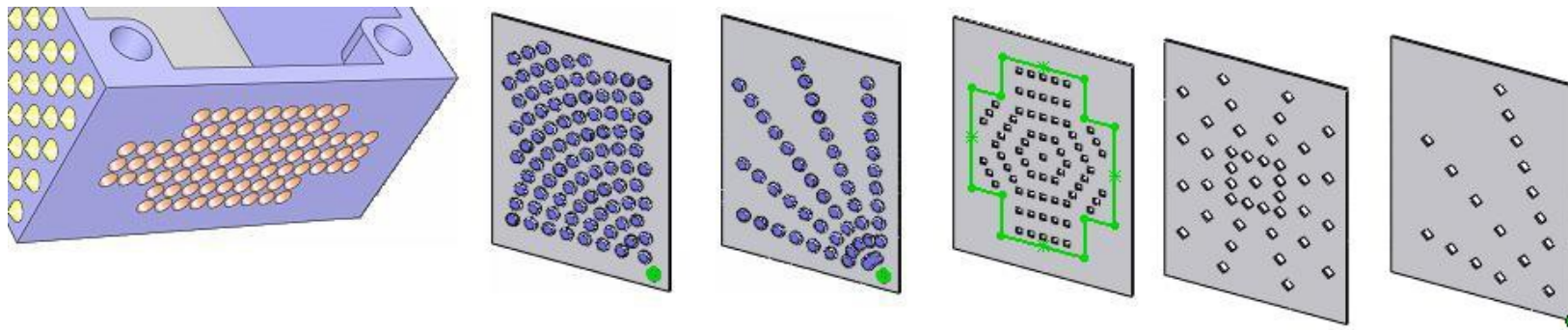

Fill Pattern Options
(Size, Shape of hole and distribution)



Sheet Metal examples with Surfaces

Sheet Metal Examples

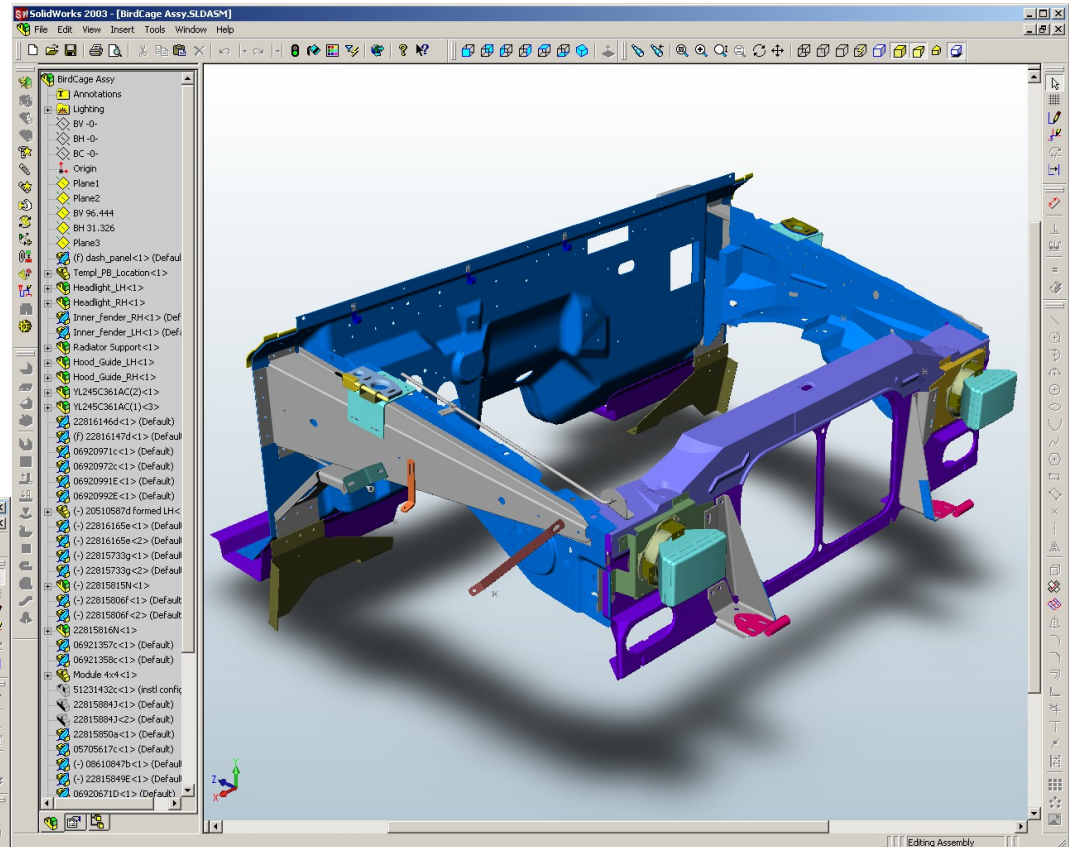
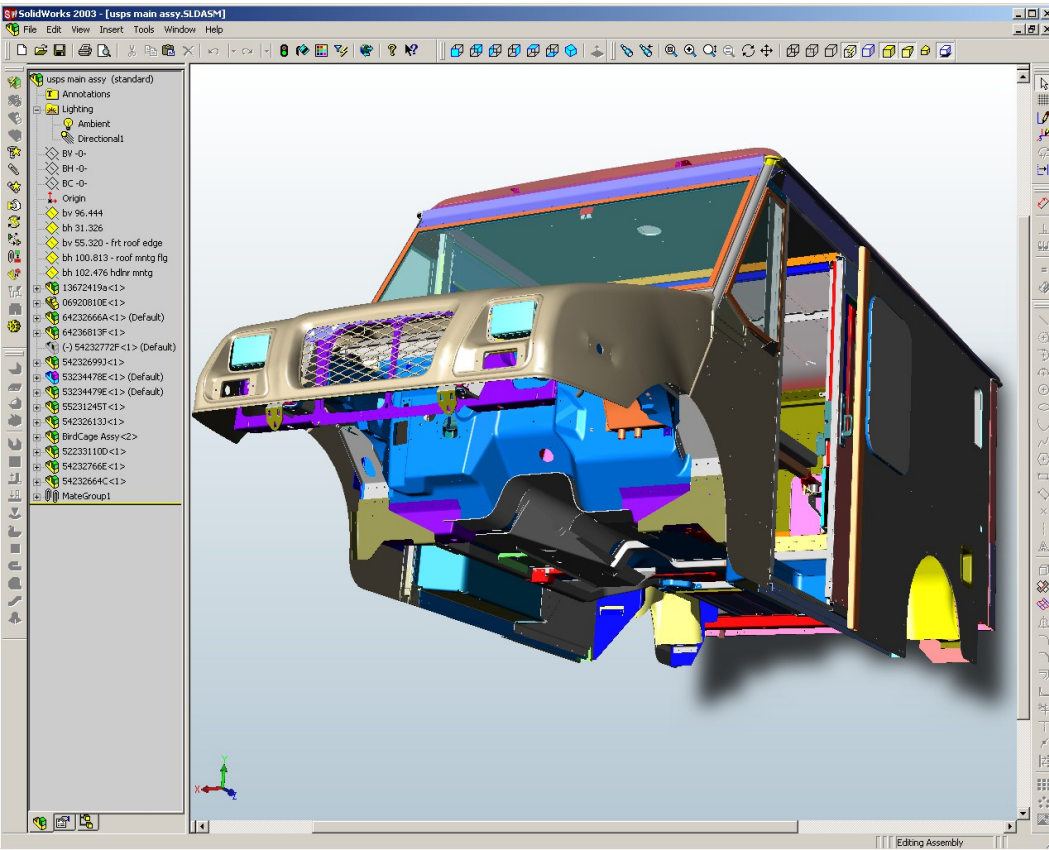

Sample Components

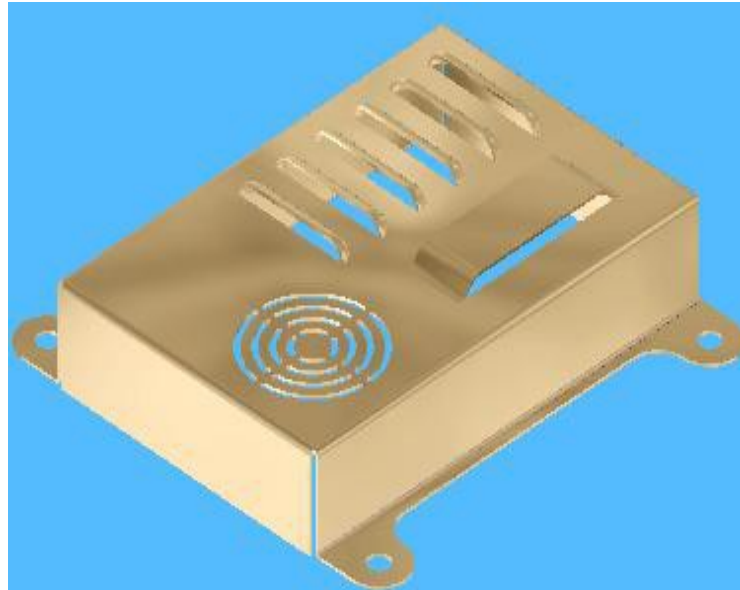
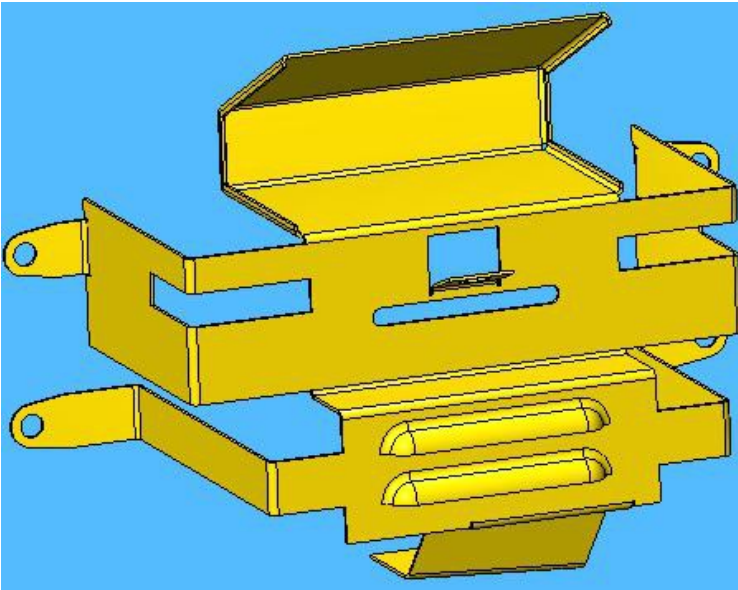
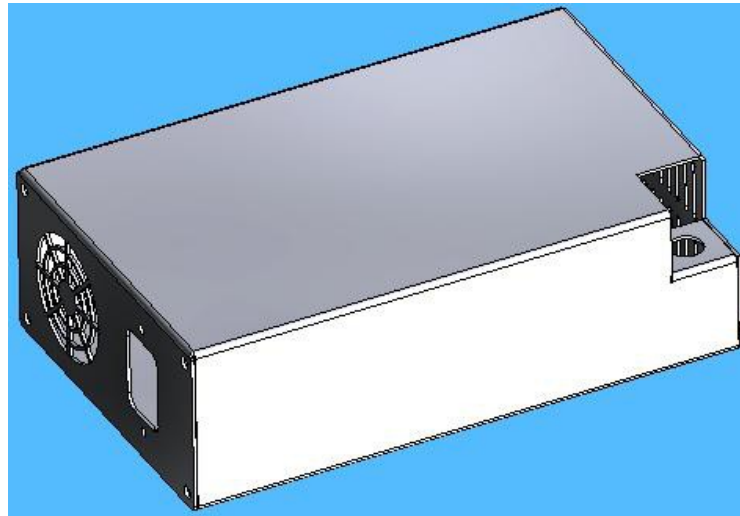
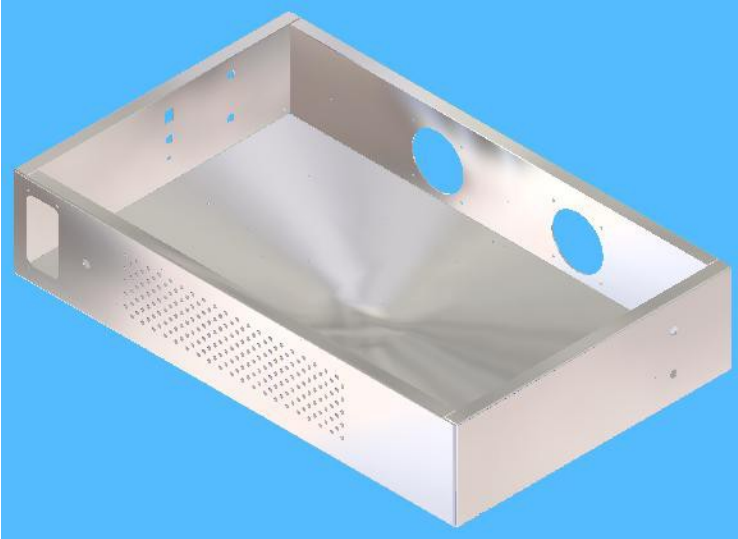

Sheet metal Assembly

- Bottom up approach
- Top Down approach
- Smart mate technique
- Smart fasteners
- Smart Component
- Physical Simulation
- Interference Detection
- Part / Assembly Library
- Exploded View
- Mass and CG Calculations

Sample Assembly

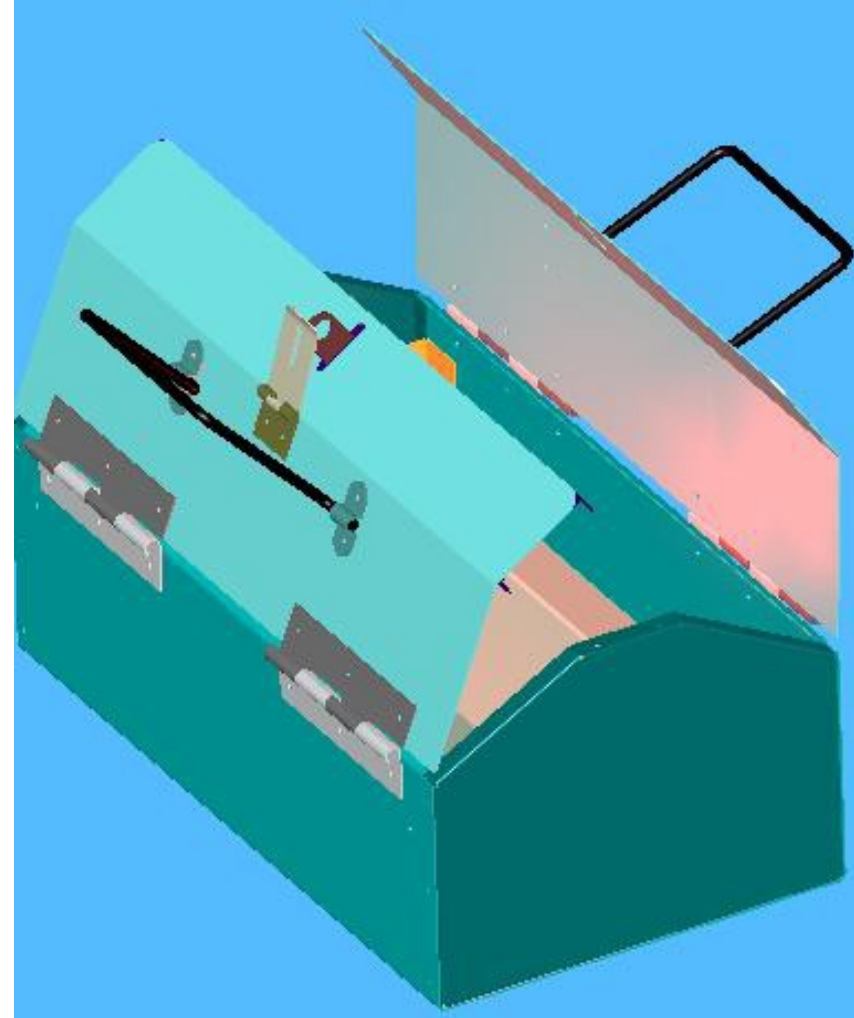
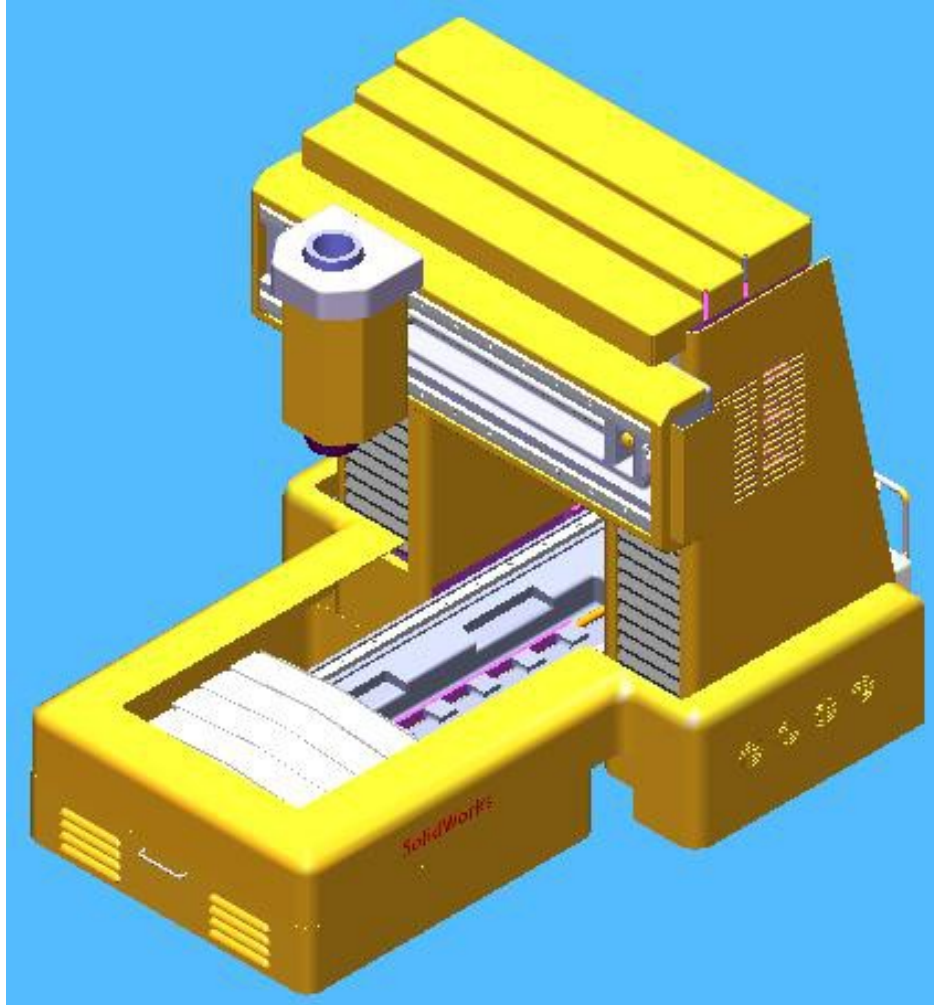

Sample Assembly

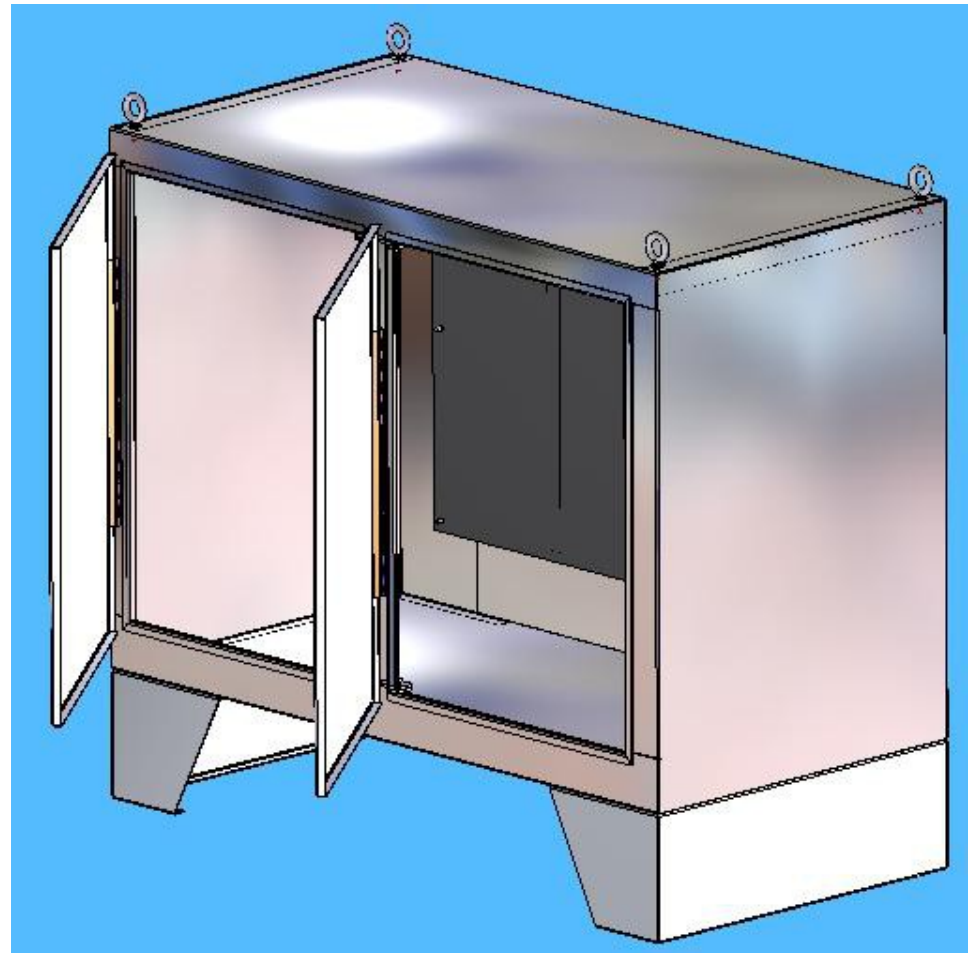
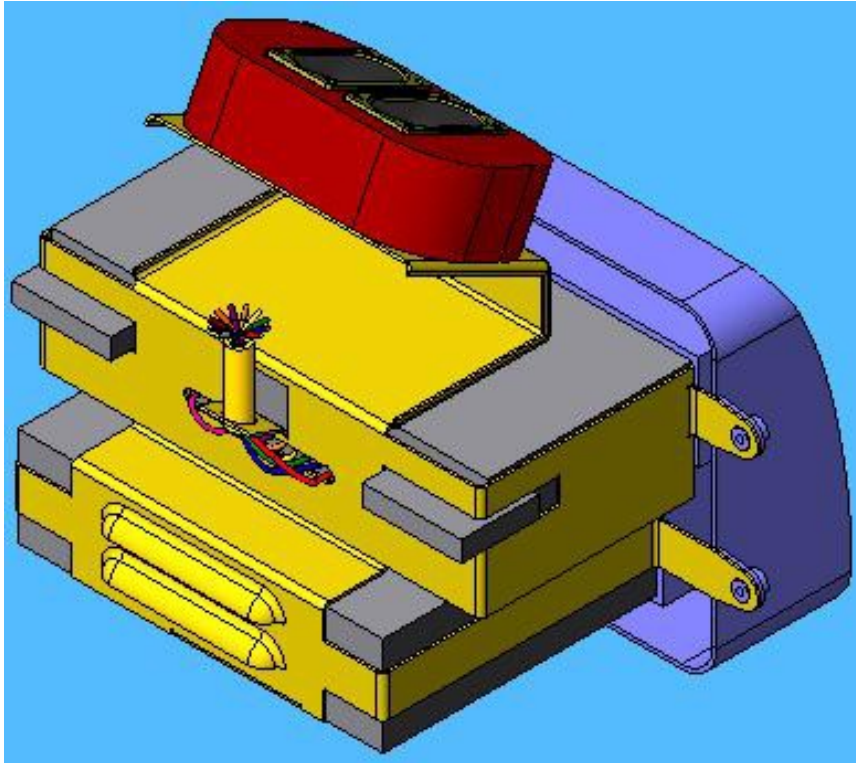

Drawing Creation

- Bi-Directional Associativity
- Flatten view with bend lines and bend notes
- Automated BOM Generation, export it as text and excel formats
- Automated Ballooning
- Exploded View
- Alternate Position view
- Automated Drawing Templates
- Save as pdf, dwg, dxf, tiff, jpeg and
- Draw Compare
- Design Checker
- Annotation Library

Sample Drawing

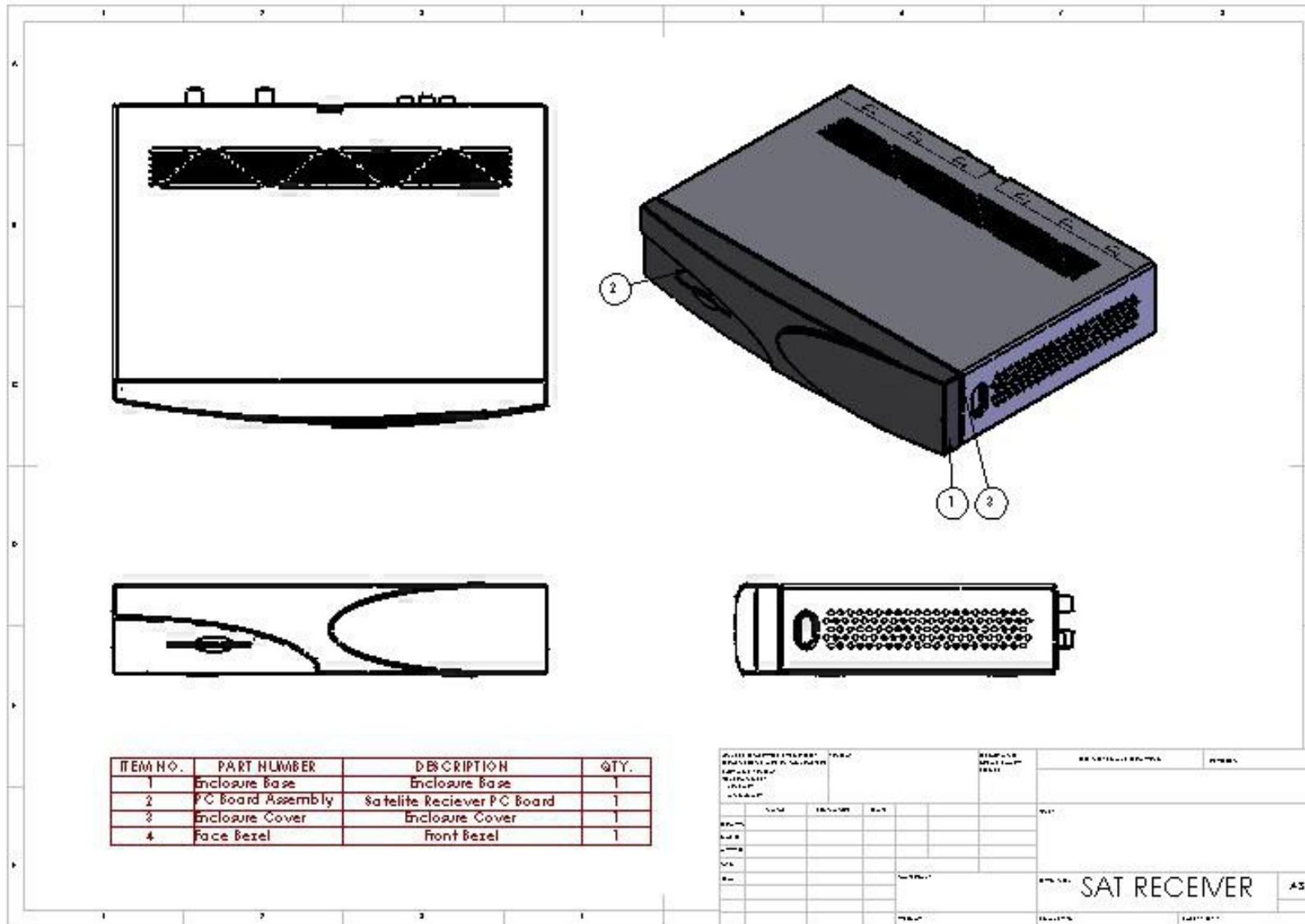

Sheet Metal Customer References

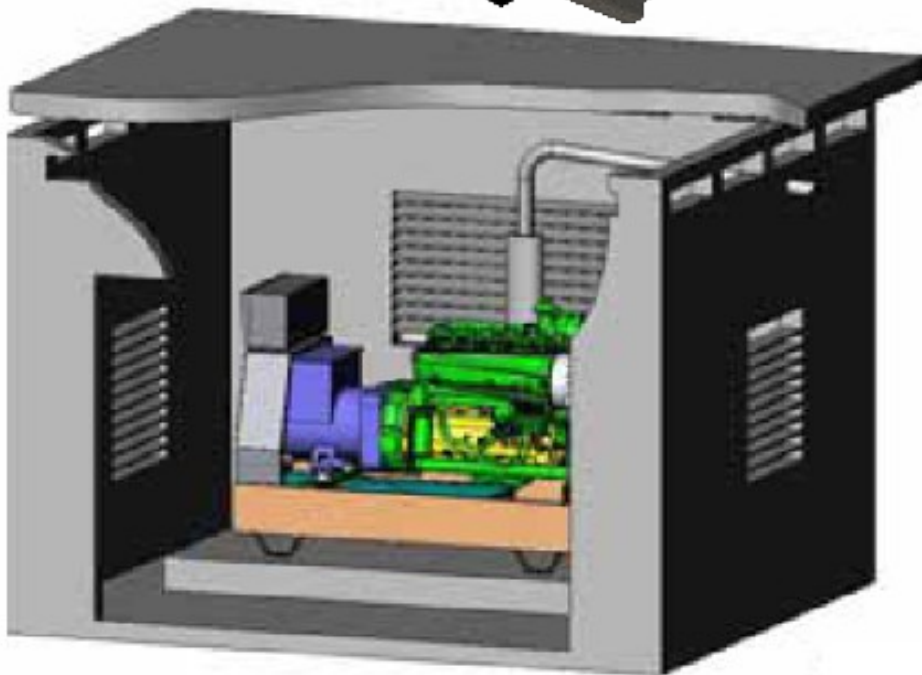
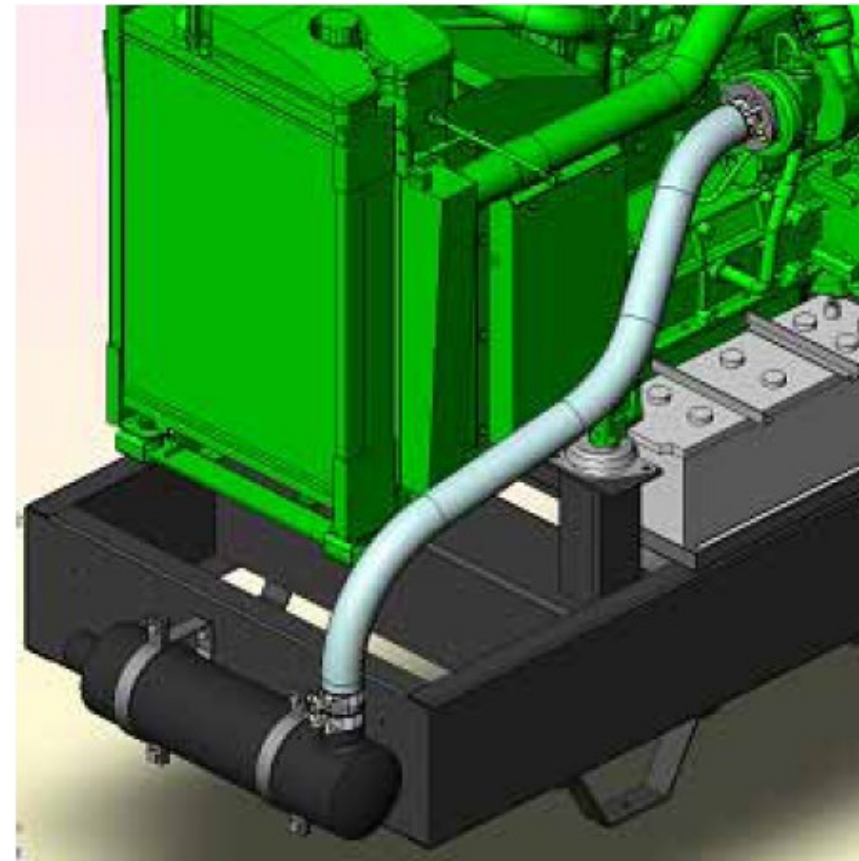

ABAMOTOR
ENERGIA

SolidWorks used in Designing Sheet-metal Enclosures

www.egsindia.com

Sheet Metal Customer References

2. GENERATING SET MAINTENANCE

Generating set description.(Fig 01)

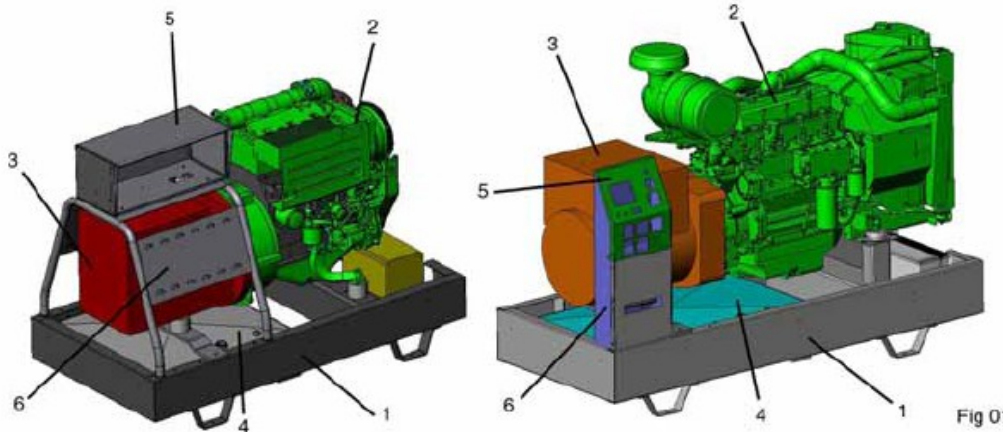

- 1. Frame
- 2. Engine
- 3. Alternator
- 4. Fuel tank
- 5. Control board
- 6. Control board support



English

Installation manuals are developed using SolidWorks

Mains points for maintenance of frame and associate components (Fig 02)

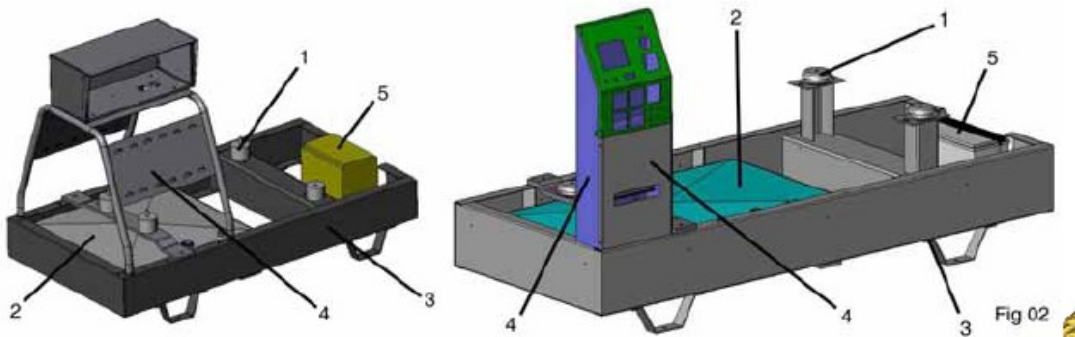

- 1. Anti-vibration mountings (AVM's)
- 2. Fuel tank
- 3. Check screw works and welds
- 4. General condition of the control board support
- 5. Battery



Sheet Metal Customer References



MODEL #	MPSG10		MPSG12		MPSD12	MPSD17	MPSD21
	PROPANE VAPOR	NATURAL GAS	PROPANE VAPOR	NATURAL GAS	NO. 2 DIESEL	NO. 2 DIESEL	NO. 2 DIESEL
FUEL TYPE							
ELECTRICAL STANDBY SURGE OUTPUT RATING	9.6 KW	8.6 KW	12 KW	10.8 KW	12 KW		
CONTINUOUS STANDBY ELECTRICAL OUTPUT	8.2 KW	7.4 KW	10.8 KW	9.7 KW	10.4 KW	17 KW	21KW
VOLTAGE	120/240	120/240	120/240	120/240	120/240	120/240	120/240
AMPERAGE	60/40	70/35	100/50	90/45	100/50	141/71	175/88
ENGINE MFG.	KOHLER-18	KOHLER-18	KOHLER-25	KOHLER-25	LOMBARDINI	LOMBARDINI	LOMBARDINI
ENGINE HP @ RATED R.P.M.	17HP @ (3600)	14HP @ (3600)	23HP @ (3600)	18HP @ (3600)	17.7 HP @ (3600)	28.50HP @ (1800)	36.72 HP @ (1800)
ENGINE DISPLACEMENT	624 CC	624 CC	725CC	725CC	871CC	2068 CC	2068 CC / TURBO
CYLINDERS	2	2	2	2	2	4	4
COOLING SYSTEM	AIR	AIR	AIR	AIR	AIR	WATER	WATER
FUEL CONSUMPTION AT FULL LOAD	10 (4.5) lbs./hr (kg./hr.)	155 (4.4) CFH(cum.ft/hr.)	12.5 (5.6) lbs./hr (kg./hr.)	194 (5.5) CFH(cum.ft/hr.)	1.1 (4.2) US gal/hr (Litres/hr)	1.90 (7.2) US gal/hr (Litres/hr)	2.24 (8.5) US gal/hr (Litres/hr)
SOUND LEVEL @ 23 FT, 7 M, NO LOAD	63 dBA	63 dBA	63 dBA	63 dBA	66.7 dBA	68.5dBA	68.5 dBA
DRY WEIGHT lbs. (kg.)	551 (250)		557 (253)		683 (310)	1322 (600)	1322 (600)
DIESEL TANK CAPACITY US gal (litre)					7.1 (27)	24 (92)	24 (92)
BASIC FOOT PRINT L x W x H	43.5 x 21.25 x 36.5		43.5 x 21.25 x 36.5		43.5 x 21.25 x 36.5	70.25 x 27 x 37.5	70.25 x 27 x 37.5
STANDARD FEATURES INCLUDE:							
SOUND ATTENUATED WEATHERPROTECTIVE ENCLOSURE							
BATTERY CHARGER							
MAIN LINE CIRCUIT BREAKER							
EXHAUST MOUNTED SPARK ARRESTING SCREEN							
STANDARD COLOR # HAL T038 LIGHT TURBO GRAY							
MPSD17 & MPSD21 HAVE GLOW PLUGS AND A BLOCK HEATER FACTORY INSTALLED							

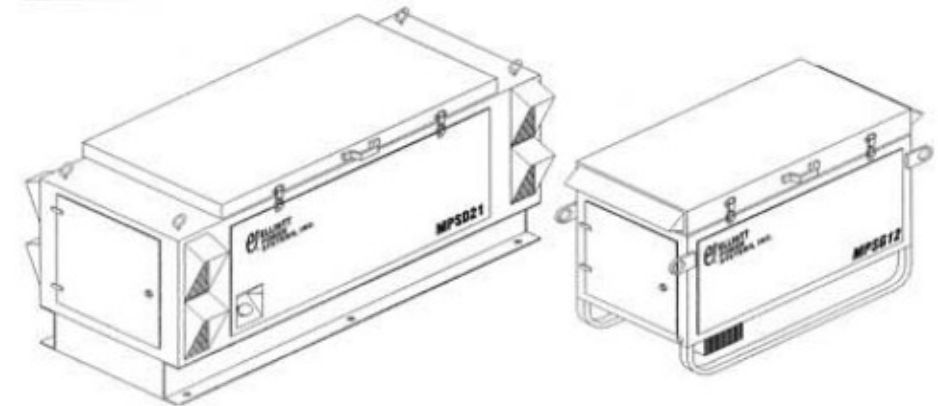

SolidWorks is used for Sheet Metal Design

Configurations used for flexible design

Reference in Power Generator Equipment

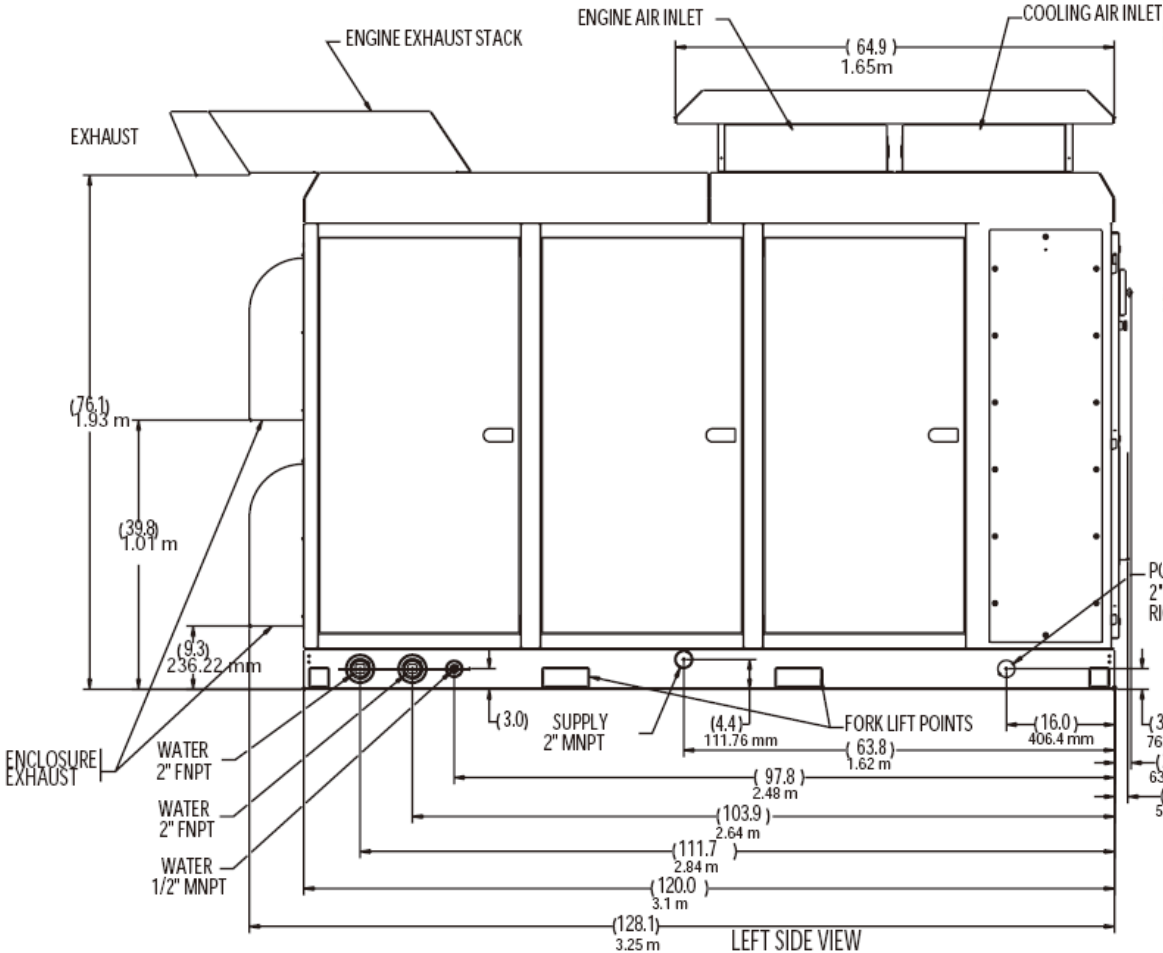

SolidWorks is used for Generator Set design at Elliott

Generation of Layout drawings in SolidWorks

SolidWorks Customer References

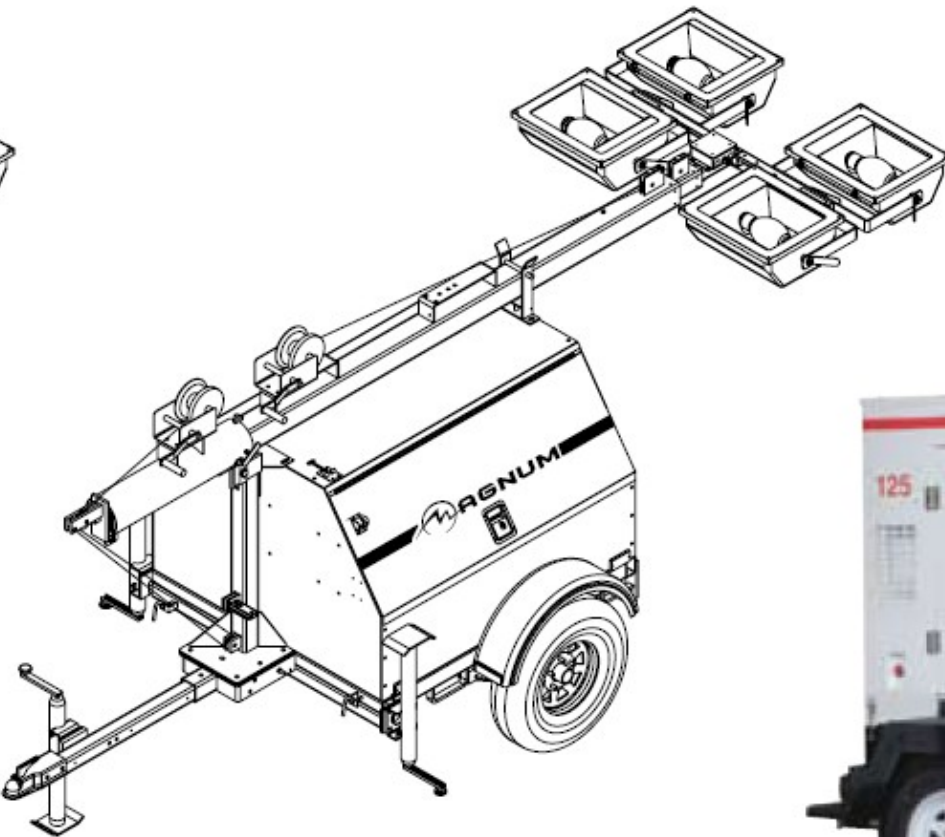

4000 Series



MODEL MMG 125

Leverages on SolidWorks 3D for Design and Downstream requirements

References in Power Generator Equipment



SolidWorks Customers

SolidWorks Sheet Metal Design References



Advanced Diesel Engineering uses SolidWorks to design canopies as shown

SolidWorks in Use



SolidWorks Sheet Metal Design
in Real-World Applications

Reference in Power Generator Equipment



Users of SolidWorks for Enclosure and Control Panel designs

Reference in Power Generator Equipment

Power-Plus DCGS3040

**30 kW, Tactical Quiet Generator Set
400 Hz, Diesel Engine Driven, Skid Mounted**

The Power Plus DCGS3040 Digital Controlled Generator is a portable, skid-mounted, self-contained unit ruggedly constructed with a proven reputation for long, trouble-free operation. The diesel engine is fully compliant with EPA emissions limits. All units are provided with digital controls, instruments and accessories necessary for operation as a single unit or in parallel with other units of the same type and rating. All components including the generator and controls have been engineered for minimum maintenance. The unit is skid-mounted and fully enclosed with an integral fuel tank and auxiliary fuel input hose and valve. This unit is the commercial equivalent of the DOD Model MEP-815B.

Standard Features

- Rugged Construction
- Digital Instrumentation
- Fully Instrumented
- Military Standard Design
- Digital Controls
- Fully Protected Circuitry
- High Reliability

SPECIFICATIONS

MODEL TYPE: Power Plus DCGS3040 Skid-Mounted, Self-Contained, Militarized, Portable, Brushless, Diesel Engine Driven Generator Set with Integral Digital Controls and 8-hr. Onboard Fuel Capacity



communications

Westwood
MC II Electric

A SolidWorks customer in
Generator Set application

www.egsindia.com

Reference in Power Generator Equipment

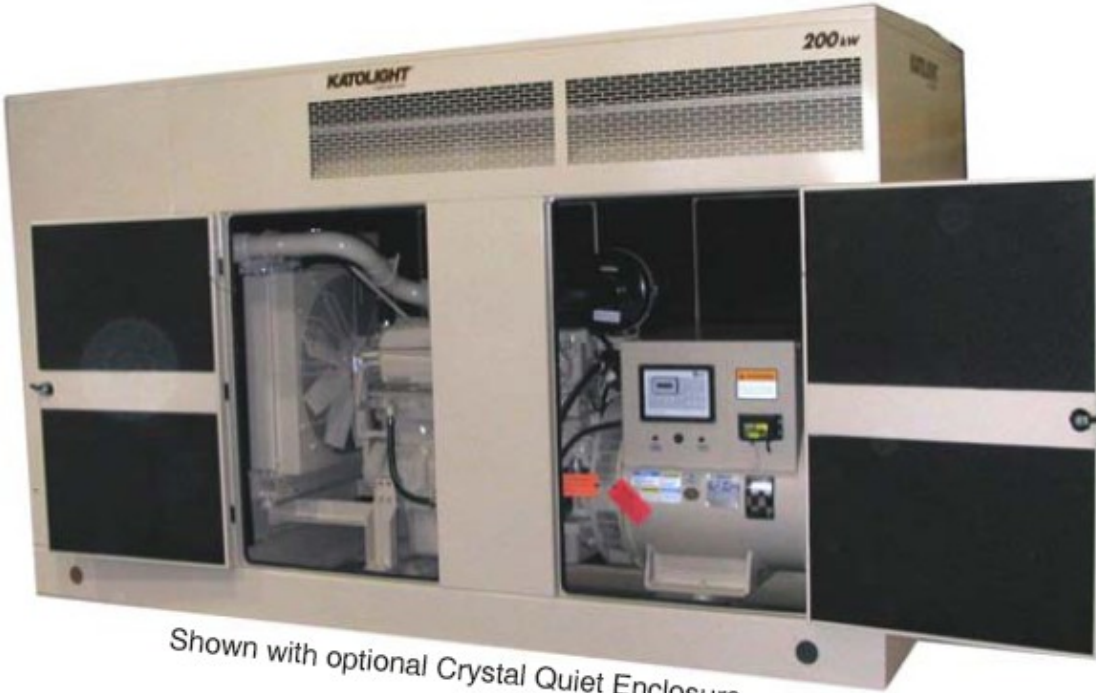

Shown with optional Crystal Quiet Enclosure



SolidWorks Customers

SolidWorks is # 1 in Production

Sheet-Metal Customer Reference

- Zero Zone, Inc. is a leading manufacturer of display coolers, freezers, and refrigerated merchandizing cases. For years, company engineers used AutoCAD® to design its products. In 1997, according to project engineer Owen Warr, Zero Zone hired an engineer intern who had experience using the SolidWorks® 3D mechanical design system.
- "The intern asked to use SolidWorks on the project he was assigned," Warr recalls. "Within months, the amount and quality of his work was a real eye-opener. In one week, he was able to design a complete product with four different-sized variations. We were impressed with the intern's effort and realized that 3D modeling could provide significant advantages over 2D."
- "SolidWorks provides the sheet metal functionality we need," says Mr. Owen Warr. "We make extensive use of this functionality in combination with configurations. SolidWorks has been very responsive in adding new features. We believe SolidWorks is one of the best design packages out there for handling sheet metal."



Results using SolidWorks:

Shortened design cycle by 66 percent
Increased sales by 335 percent
Reduced ECO process by 85 percent
Cut number of prototypes by 78 percent



Sheet-Metal Customer Reference

Creative designs Chiller Cabinet for Syspal Ltd.

Creative Design's work for Syspal Ltd. is a great example of how using SolidWorks native data to communicate saved time and money. Syspal, the UK 's number one supplier and manufacturer of stainless steel and aluminium products, won the contract to supply Chiller Cabinets to the company Bombardier for the refurbishment of the GNER Mark IV railcar rolling stock. Bombardier Transportation is the global leader in the rail equipment, manufacturing and servicing industry.

Lead times were very tight so Syspal commissioned Creative Design, an award winning product design consultancy, to design the new cabinet. Creative was commissioned in large part because they were experienced SolidWorks users, therefore able to provide files that would be native to Syspal's in-house SolidWorks system. This would make it much easier to meet the tight delivery time. **Creative's use of SolidWorks reduced time to market by at least 20 percent.**

The assembly was based around stainless steel and aluminum fabrication and the development program **exploited the sheet metal functions of SolidWorks to the full.** Having agreed upon details such as bend allowances and notching parameters to suit Syspal's manufacturing equipment, the sheet metal parts were laser profiled directly from the flat patterns generated in SolidWorks.

Creative, enabled by SolidWorks, was able to complete Syspal's commission with great success. The design program was completed in 4 weeks from being briefed and included the creation of 81 unique parts, 17 sub-assemblies and 65 associated production drawings.



Customer Story of Migrating from Autodesk Inventor



Mann + Hummel Hydromation is the leading producer of automated coolant filtration and swarf (metal chips) handling systems for use with industrial processes involving high-speed metal cutting. The company designs, constructs, and installs its systems in large manufacturing plants for a range of customers, including major automobile manufacturers. Mann + Hummel Hydromation used Autodesk Inventor® 3D design software to develop its systems until 2003.

While attending a trade show, company representatives saw a quick demonstration of the SolidWorks® 3D mechanical design system in 2003 and began evaluating the software for implementation, according to Dirk Novak, CAD coordinator. “We were particularly interested in how SolidWorks handled large assemblies, which are used heavily in the

development of our coolant filtration and swarf handling systems,” he says.

Novak asked his local SolidWorks reseller, Cadmes Belgium, for a complete

demonstration. **“When I saw SolidWorks configuration capabilities, I was impressed by the power and flexibility of the software, and realized we needed those capabilities to energize our product development effort,”** notes Novak.

“We also saw the potential for using SolidWorks sheet-metal capabilities and the SolidWorks Routing package for further automating systems development.”

“After we saw the capabilities of SolidWorks software, we believed we could realize a range of productivity improvements by implementing SolidWorks across the board for all new product development,” Novak adds.

Mann + Hummel Hydromation chose to migrate to SolidWorks software, installing 15 seats, because of its large assembly, configuration, and sheet-metal design capabilities.

The company wanted to tap the software’s performance power, robust application program interface (API), and versatility. The company also uses SolidWorks Routing software for routing cables, wiring, and piping throughout its custom-designed cooling and filtration systems.

Results using SolidWorks:

- Reduced design cycles by more than 30 percent
- Shortened time required to make design changes by 90 percent
- Improved quality and minimized design errors
- Enhanced design communications with existing & prospective customers

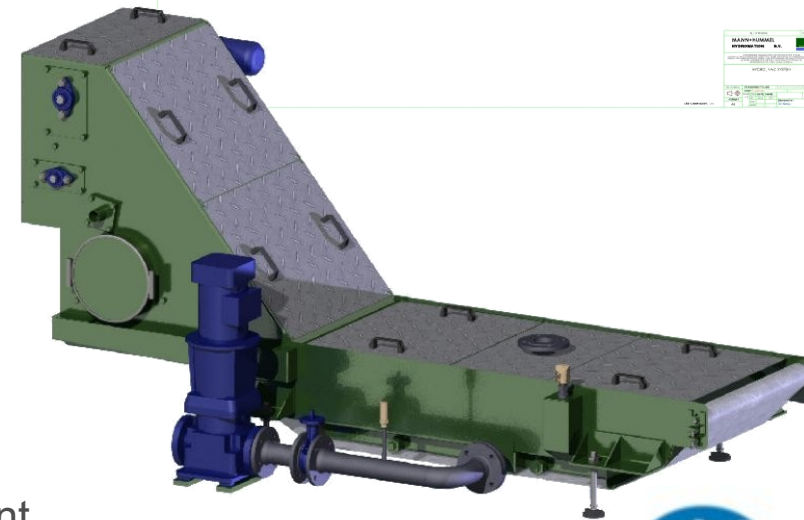
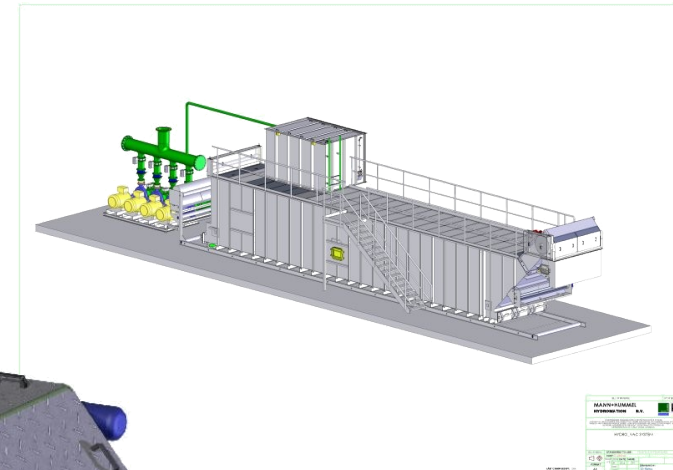

Sheet Metal Examples

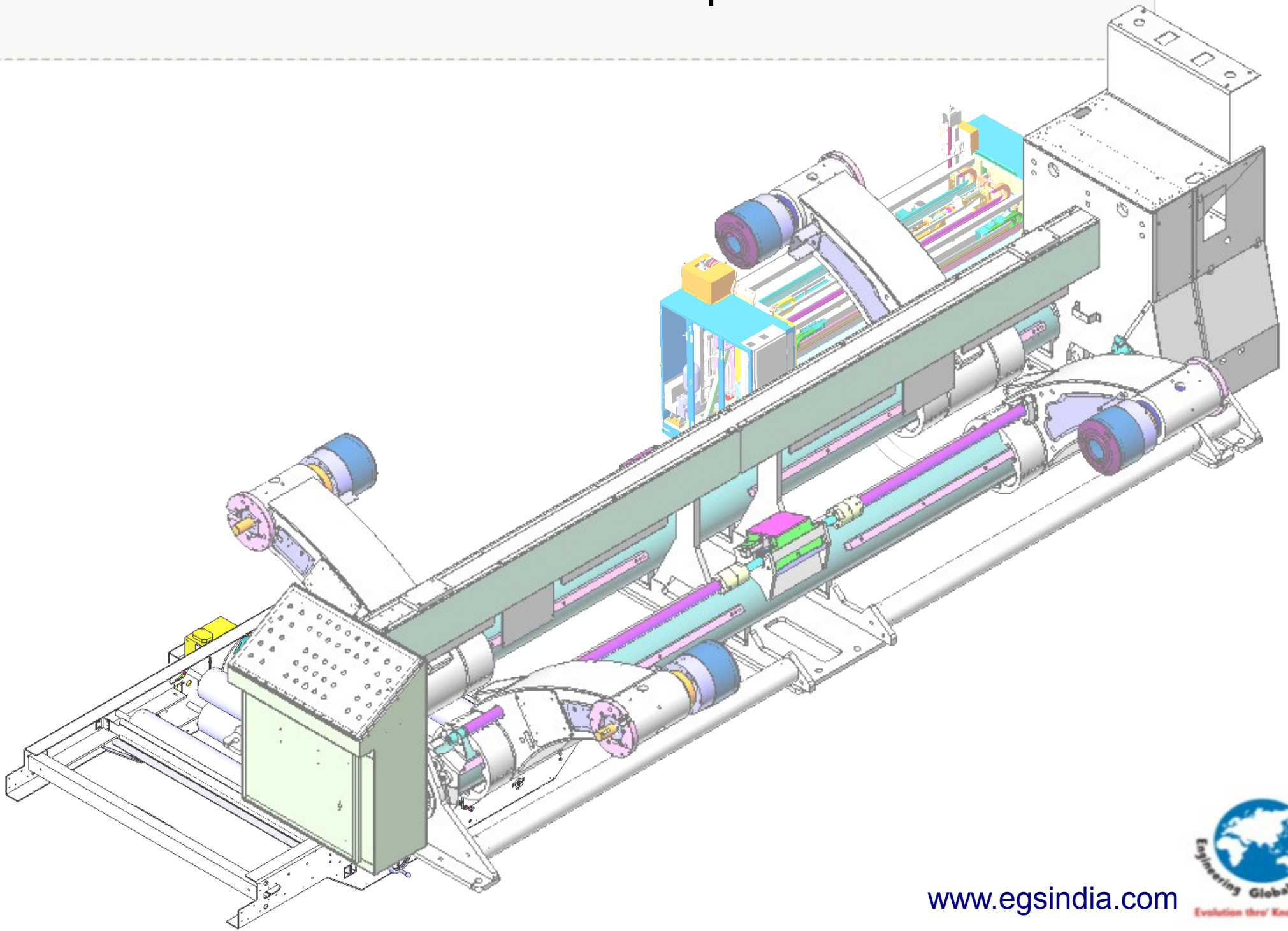

Sheet Metal Examples

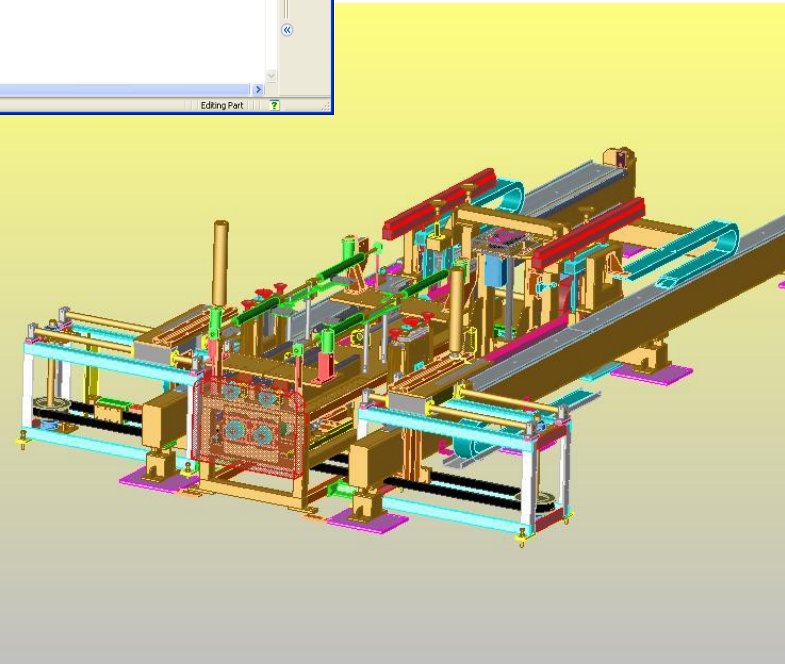
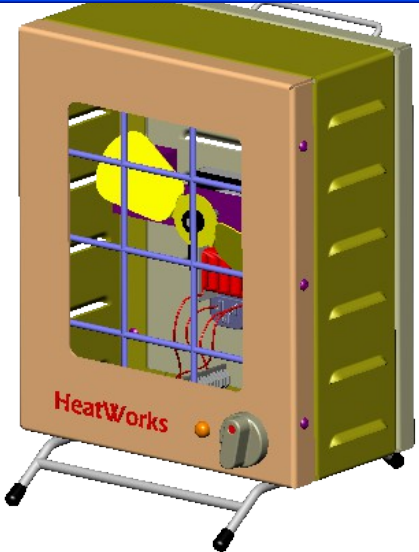
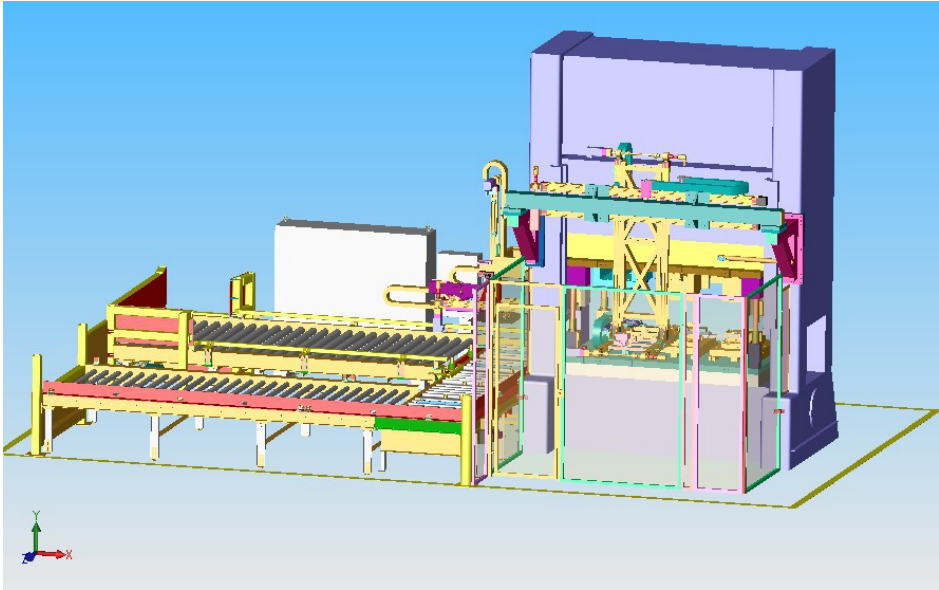
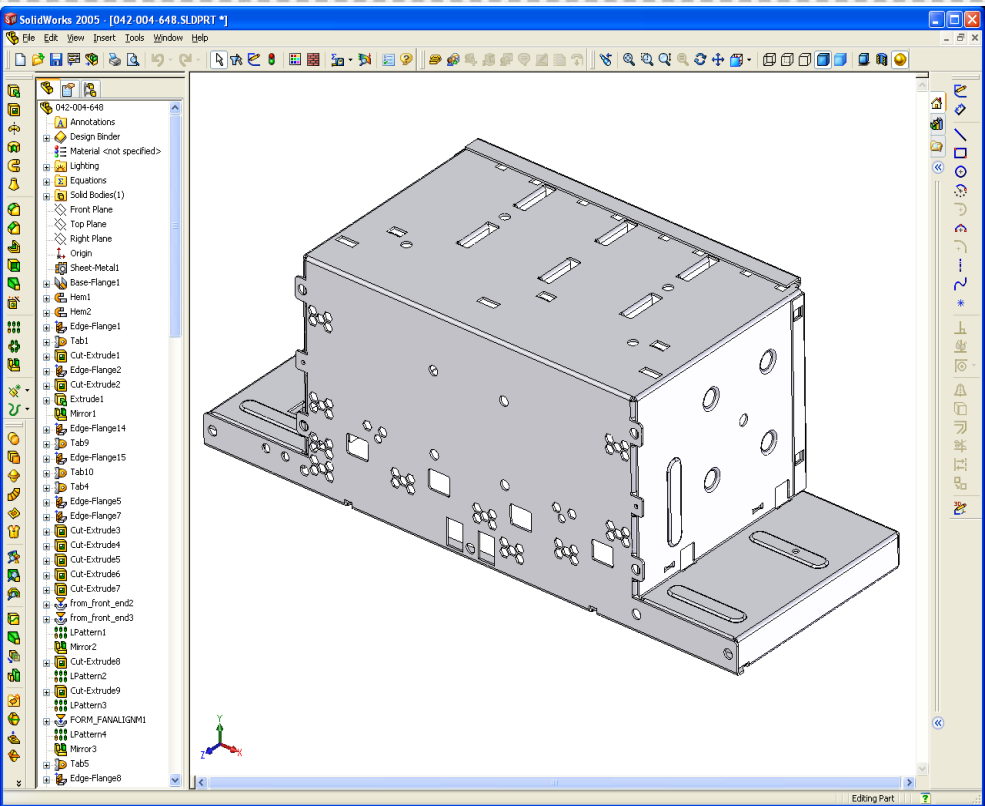

Sheet Metal in action

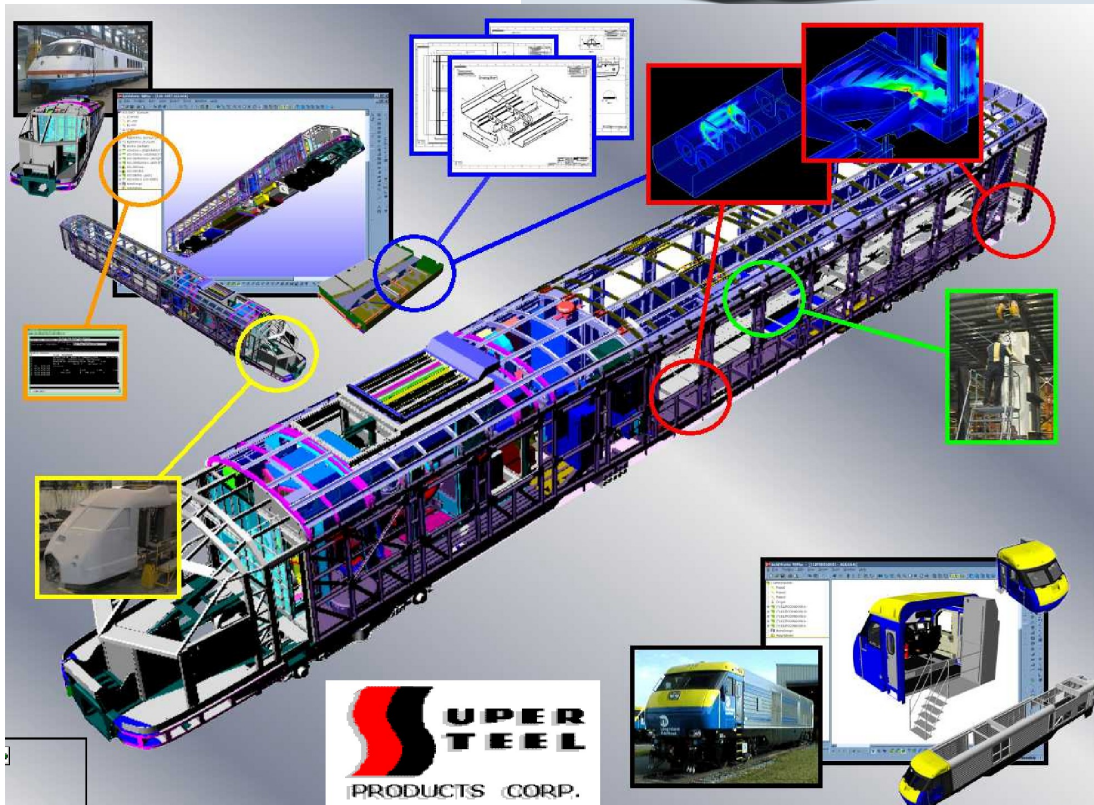

Sheet Metal assemblies in complex shapes

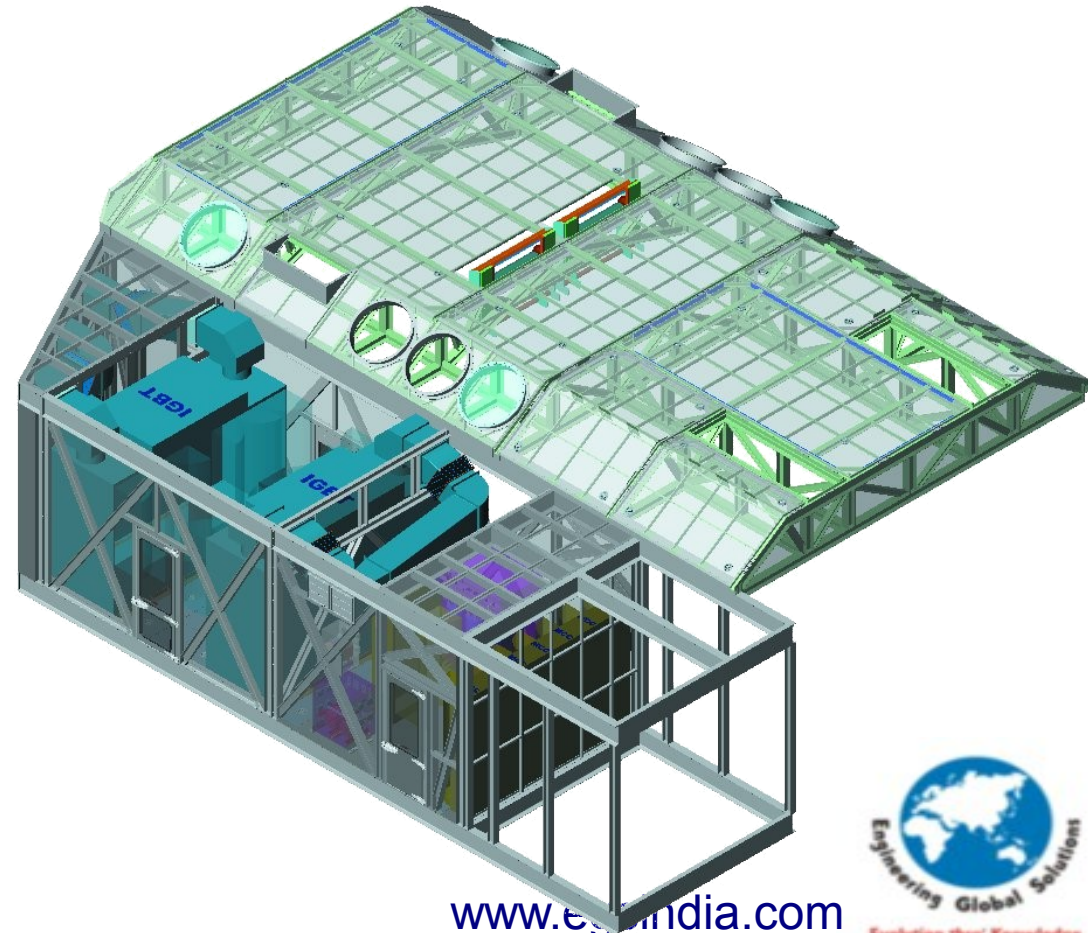
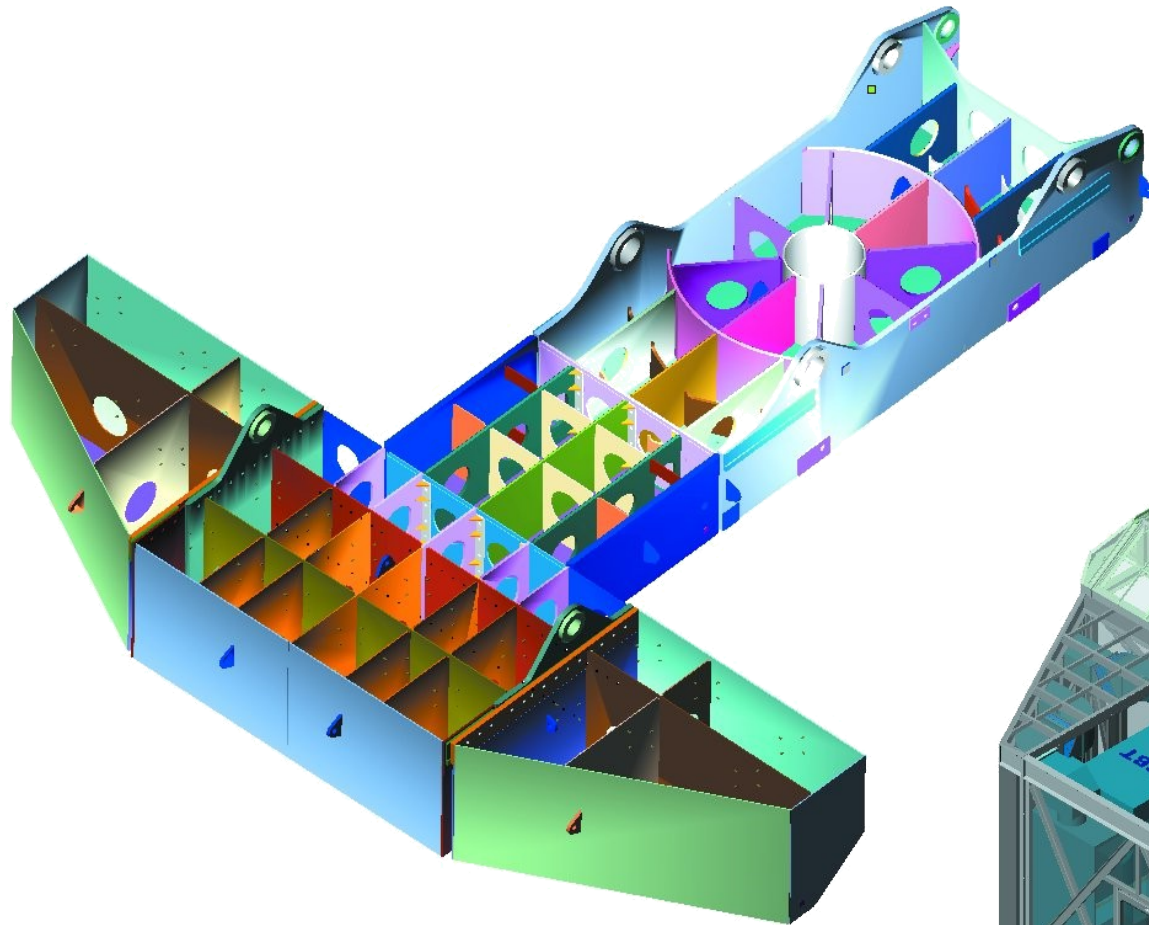

Fabricated Sheet metal design

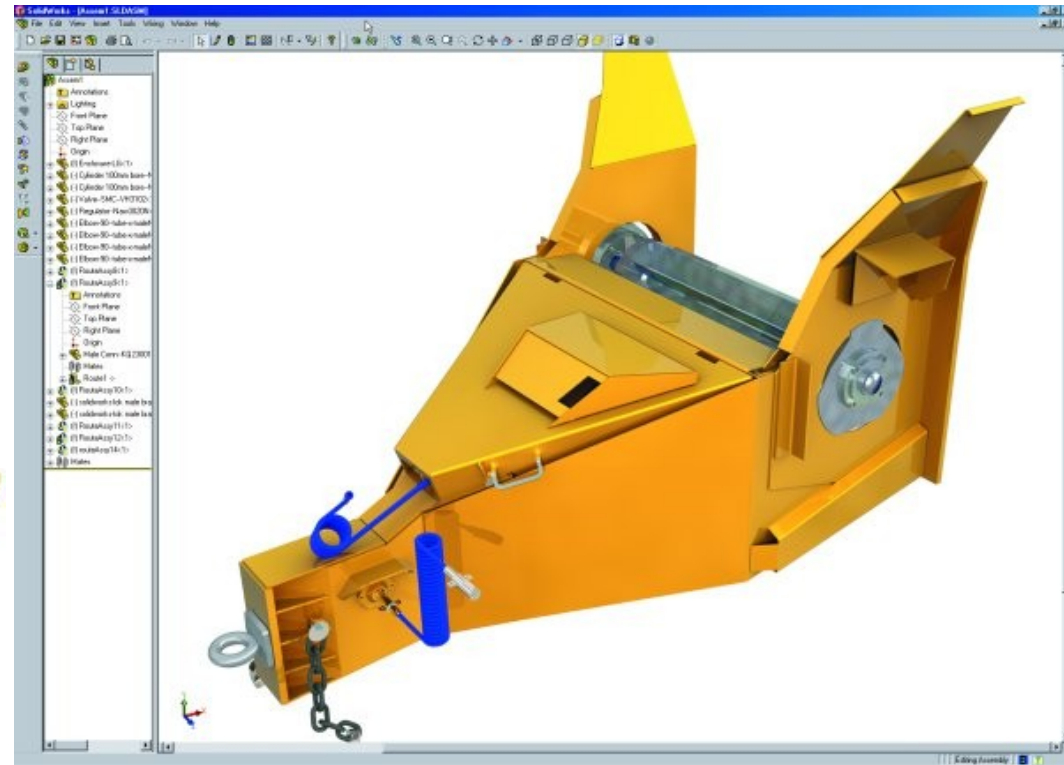
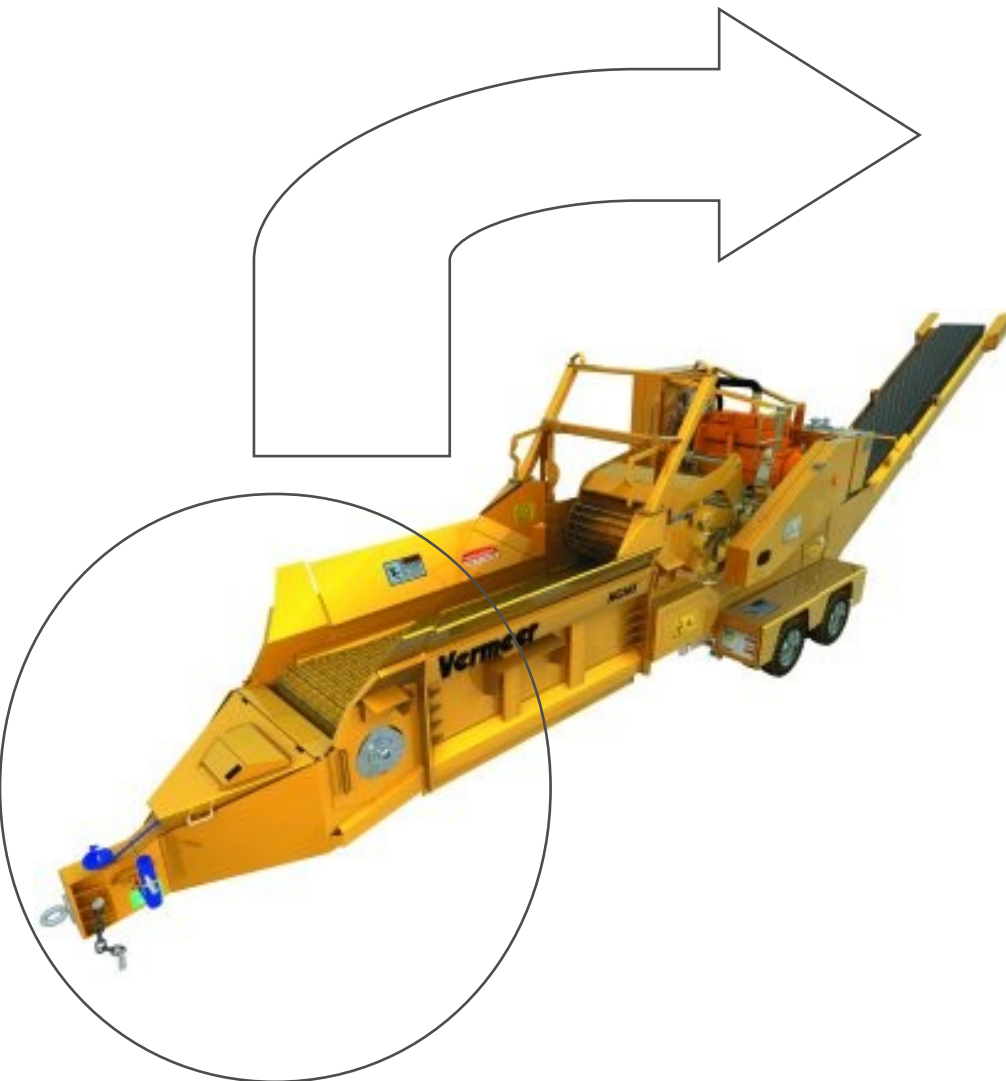

SolidWorks Design in production



Sheet Metal Design Alternates in SolidWorks

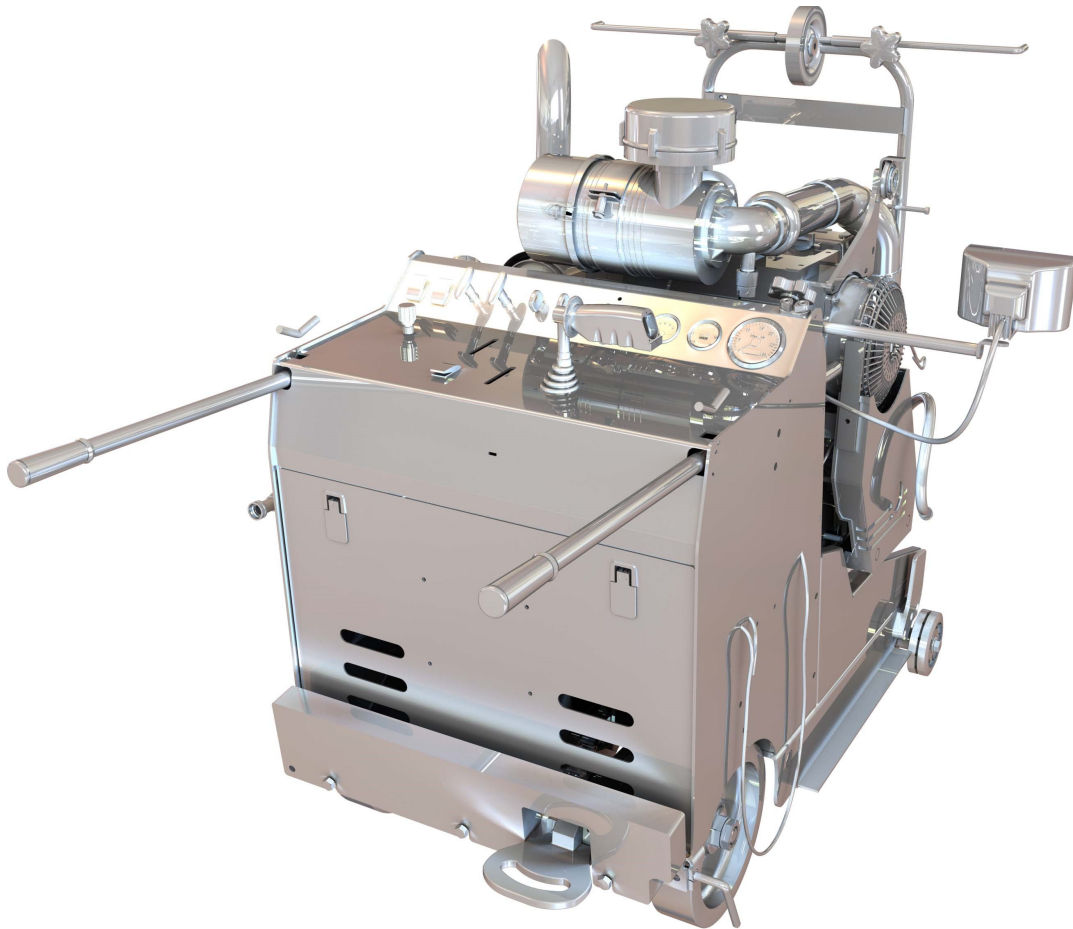

Rendered in SolidWorks

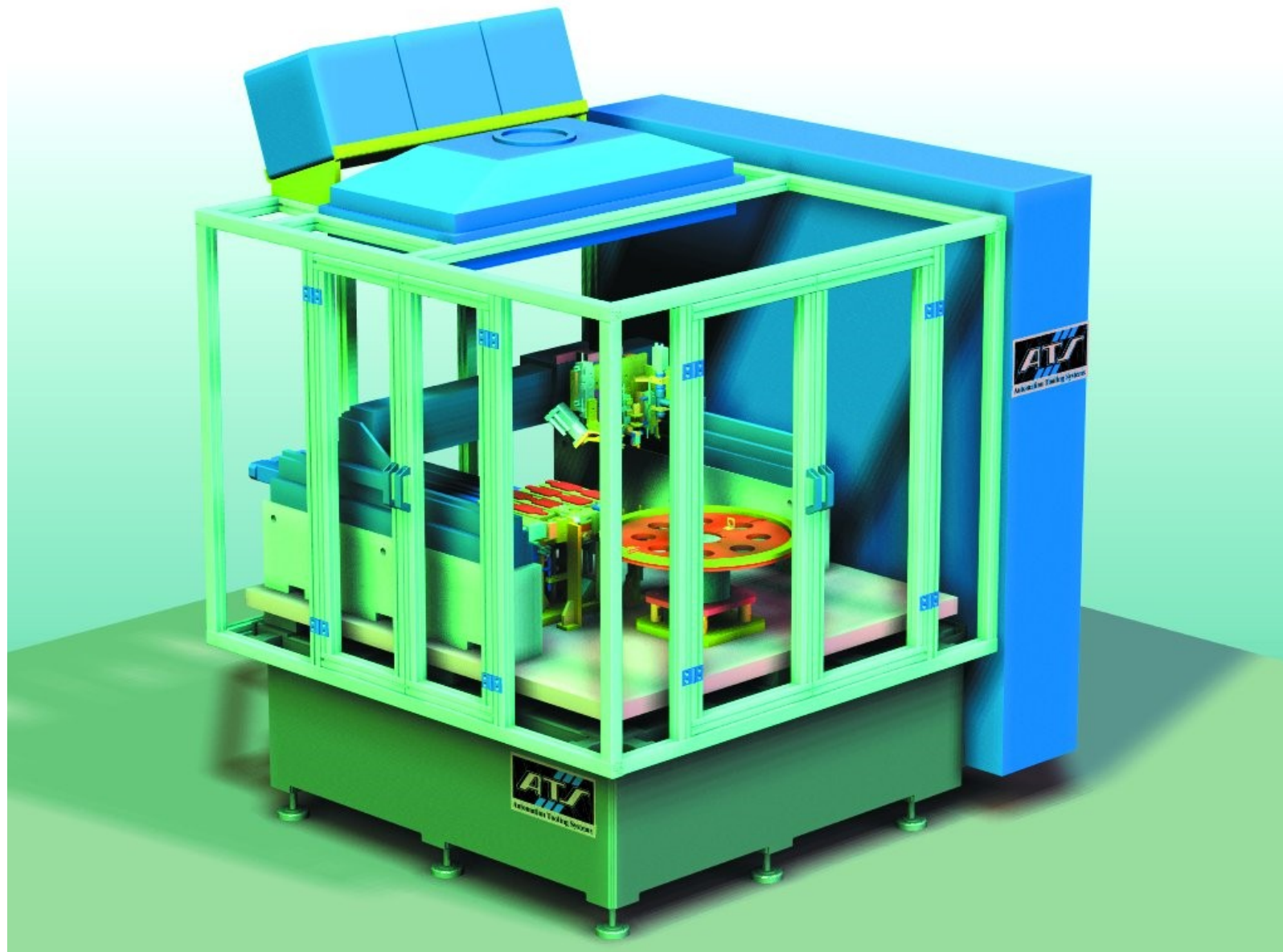

Very Large Sheet Metal assembly in SolidWorks

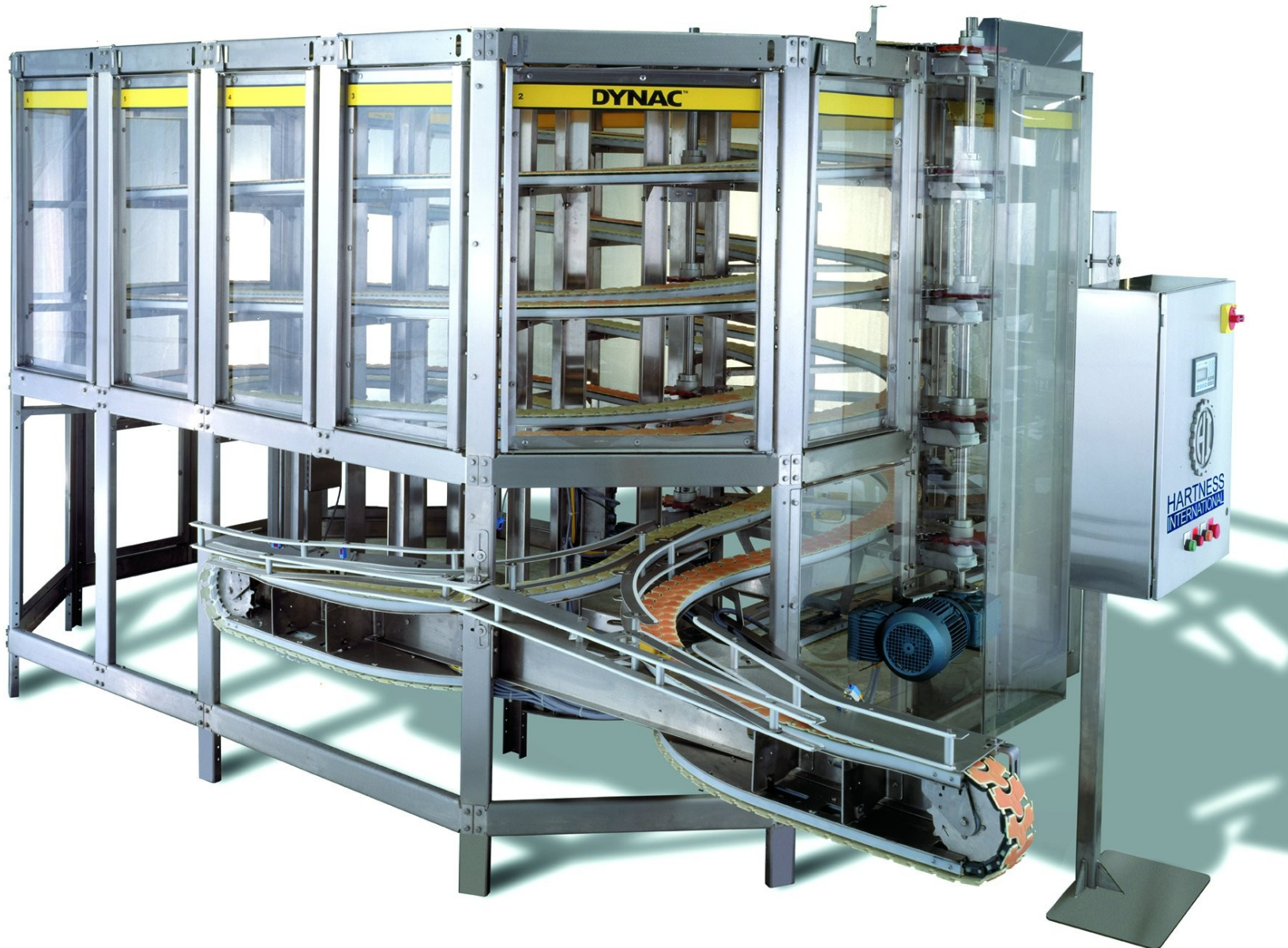

Machine made of Sheet metal components

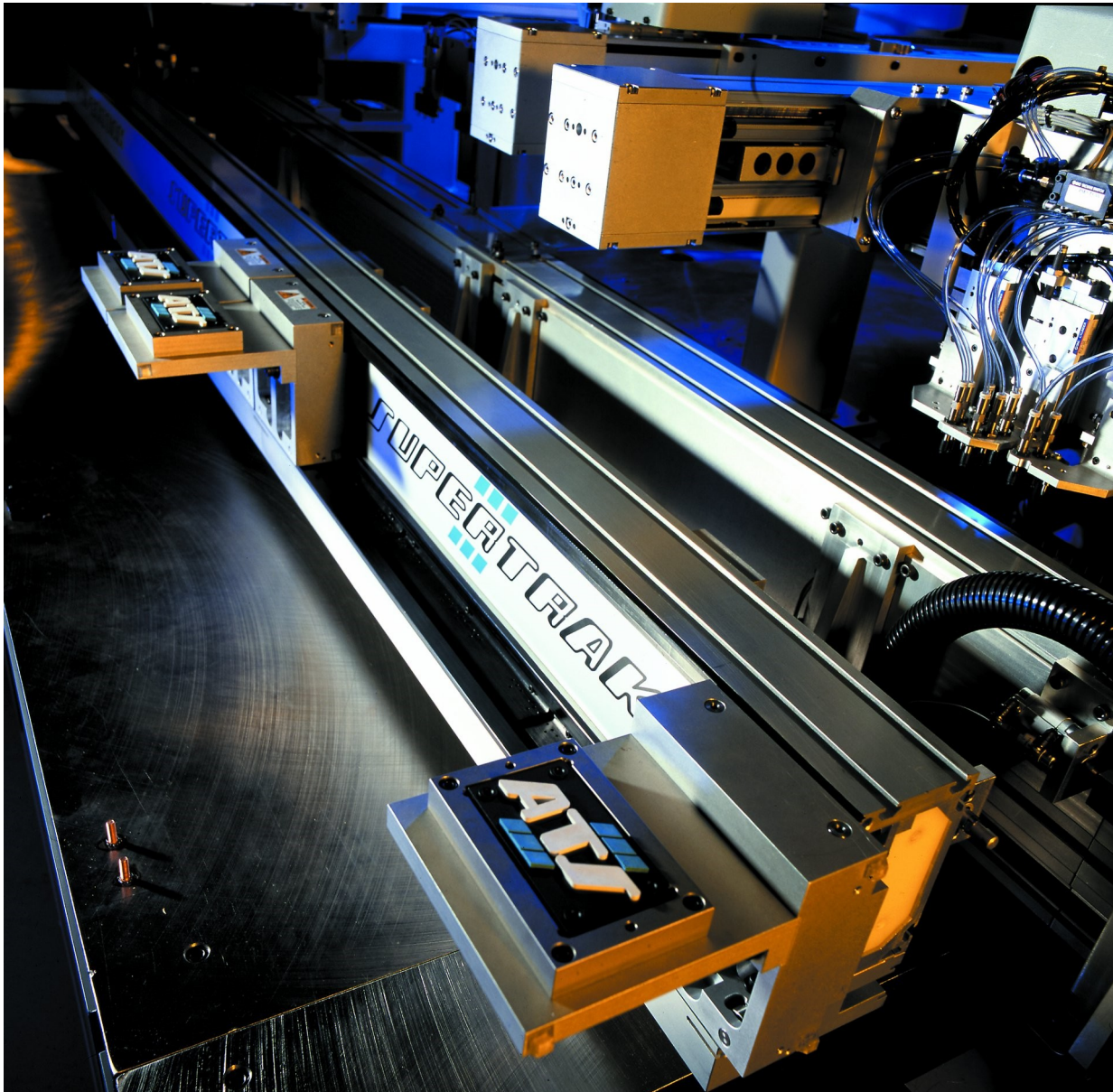

Designed and Developed using SolidWorks

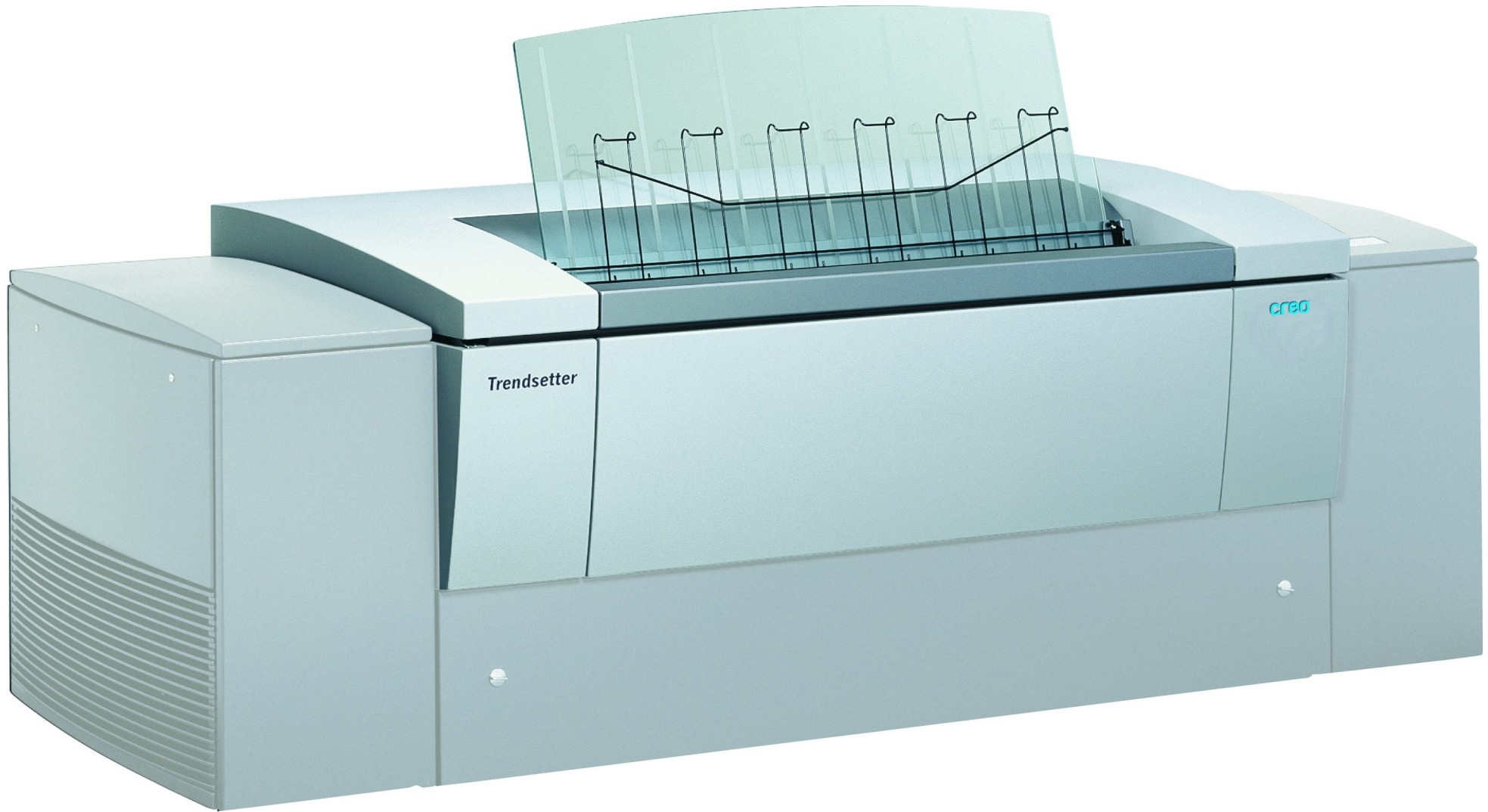

Ergonomic sheet metal design in SolidWorks

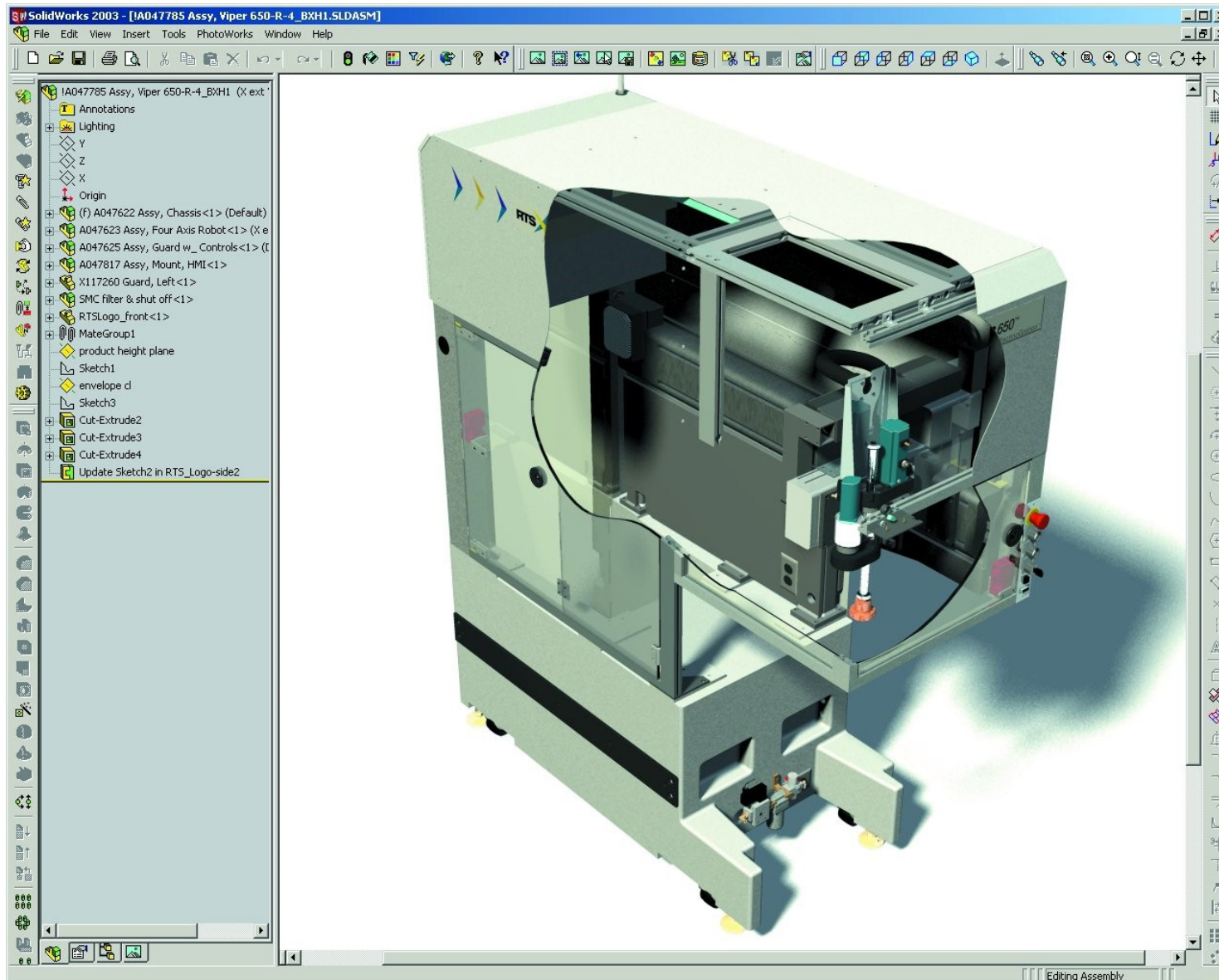

Sheet metal design in progress

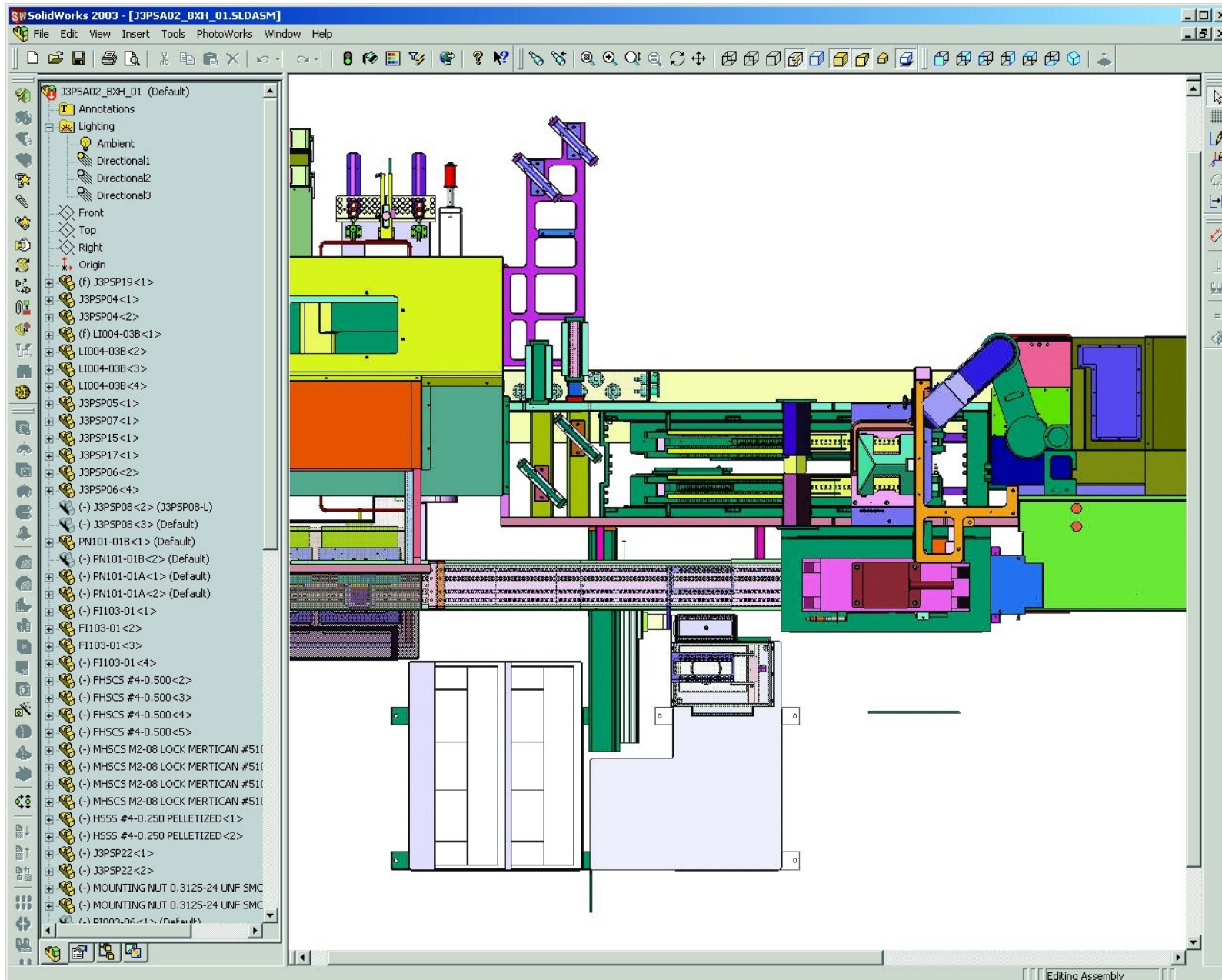

New Product developing using SolidWorks Sheet Metal



Sheet metal in Cooler Display



Sheet metal in Machine Tool Application



Sheet metal in batch processing

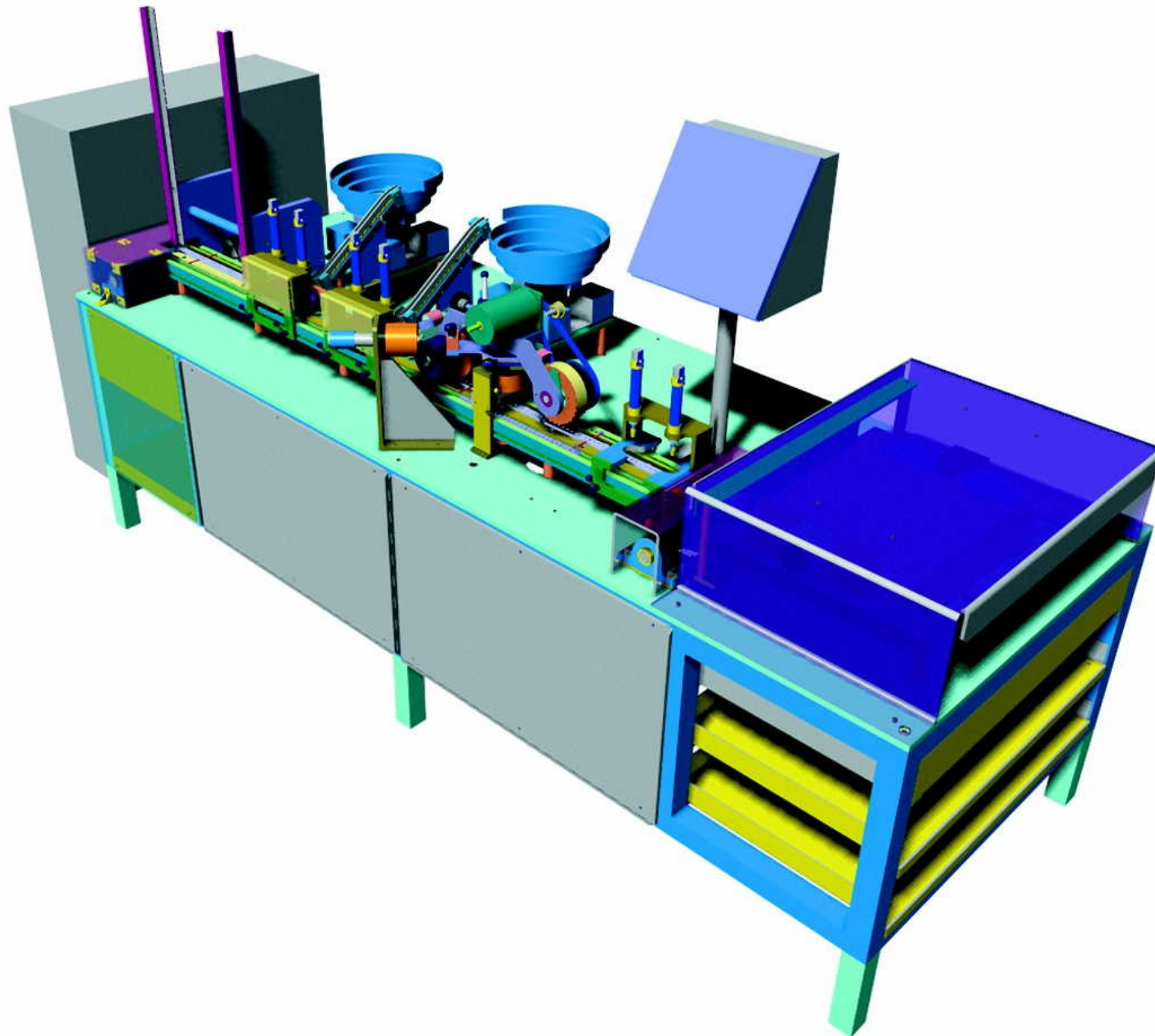

Sheet metal internal in medical application

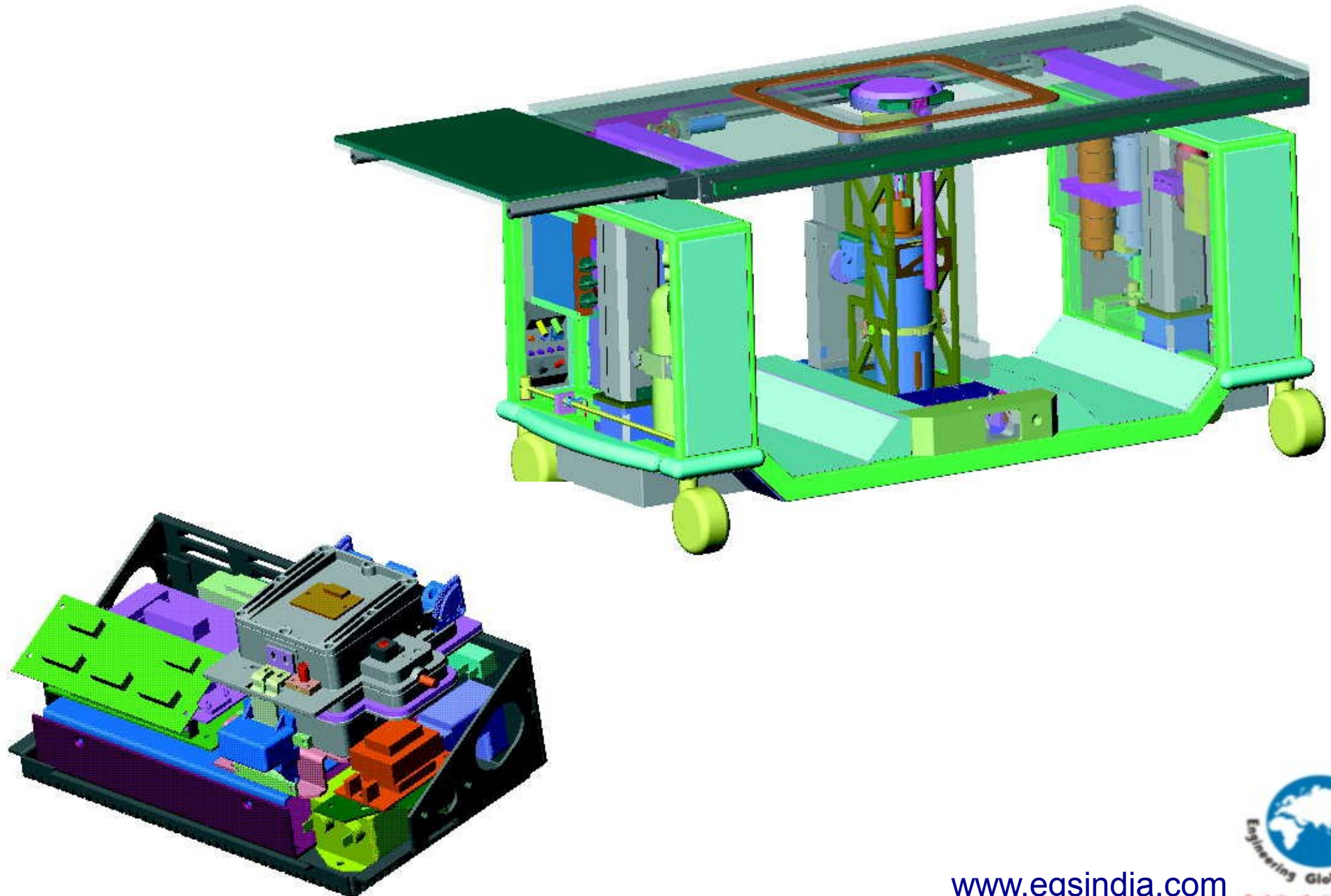

Sheet metal in Switch gear application

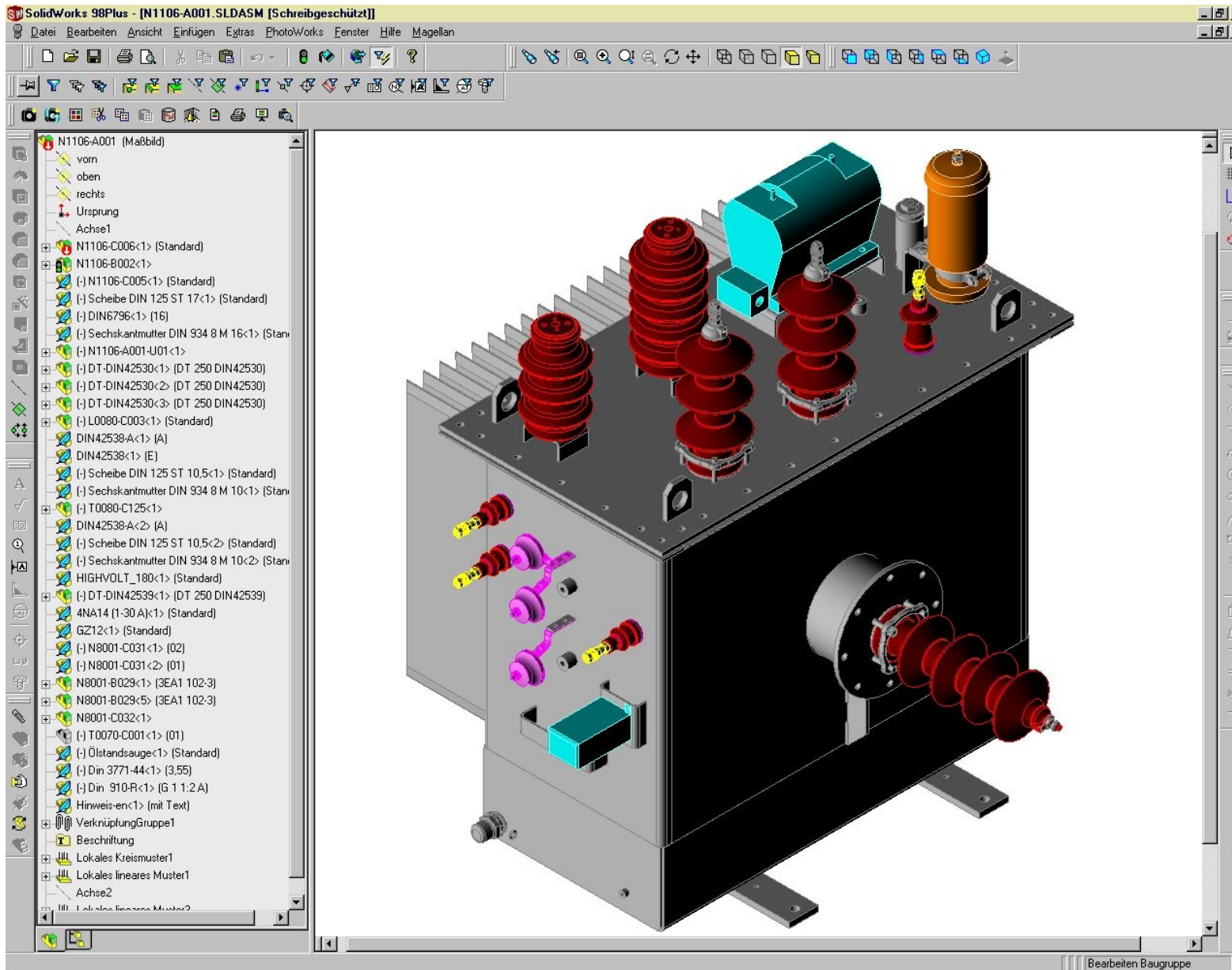

SolidWorks Everywhere in Sheet Metal

PANS AND SINKS
JK Mold design
USA



STOVE
Comet Kato
Japan



VENTILATION
Advance Metal Products
Australia



FURNITURE
Teknion Furniture Systems
Canada



PLATE DISPENSER
Tom Stoddart
Australia



COUNTERS
Abk Innovent
Netherlands



RANGES
Foster SPA
Italy



COOKING EQUIPMENT
Werner & Pfleiderer
Germany



SCULLERY
Elkay Manufacturing Co.
USA



STOVE
Aliberinox
Spain



PIPES
Dinex
Latvia



COUNTERS
Arecov
Mexico



CABINETS
Distform
Spain



COOKING DRUMS
Tecnozim
Portugal



PULL DOWN SHELF
Knappe & Vogt
USA

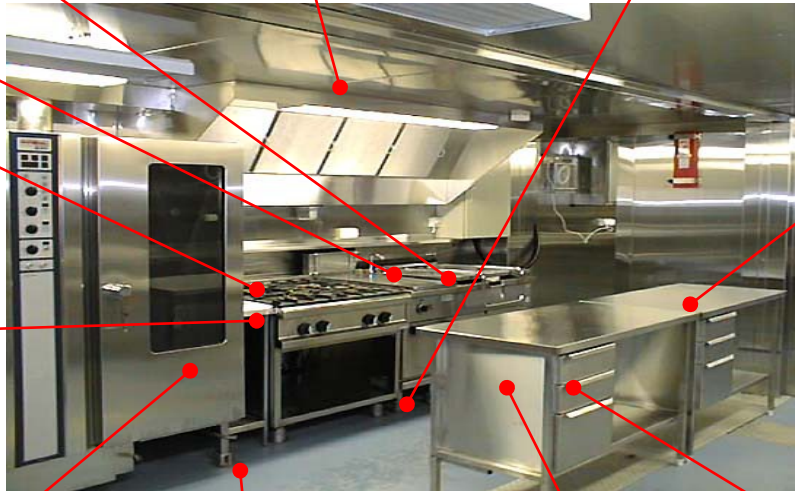

SolidWorks Customers Worldwide

Honeywell

ALSTOM

BAKER HUGHES



RAFAEL
ARMAMENT DEVELOPMENT AUTHORITY

ABB



Polaroid

INVACARE

DataCard

The Babcock & Wilcox Company
world leader in power generation
equipment design, supply and service

APPLIED MATERIALS*

BOSCH



electrogilas

PAPER CONVERTING
MACHINE COMPANY

SUNRISE
MEDICAL



Sandia
National
Laboratories

Mazak

HITACHI

TERADYNE

LifeFitness

Swagelok

barmag

Sumitomo Heavy Industries, Ltd.

EACON

DOVER CORPORATION

MADA

OMRON



ROMI

GUIDANT

Kimberly-Clark

BORG WARNER

CORNING

Panasonic

MAKINO



Halliburton Company

www.egsindia.com



Key Customer References in Japan



Why Invest in SolidWorks?

- **Proven Technology preferred by over 2 Million Users world-wide**
- **Protection and re-use of existing 2D CAD data**
- **Benefit by becoming a member of 3D Content Central and display your products for higher visibility in the world market**
- **Trusted technical support from EGS India, since 1993**
- **One-stop solution for changing needs**
- **Scope for new product development**
- **Communicate in 3D with Customers and Suppliers**
- **Standard 3D CAD Software used by manufacturing companies world-wide**
- **Safe investment with a Global Company with Extensive Presence in India**

Get Started Today



Authorized Reseller for SolidWorks since 1999

EGS Computers India Private Limited

'Design Towers' 16/32 Fifth St., Dr. Subbarayan Nagar, Kodambakkam

Chennai 600024 INDIA

Tel: 044-2480 3370 * 044-2472 1212

Fax: 044-24844227

E-mail: info@egs.co.in

Web: www.egsindia.com

Request
a
Quote

SolidWorks Certified Support Centre

www.egsindia.com

