

Pressure Regulators K Series



- Pressure-reducing models
- Back-pressure models
- Gas cylinder changeover model
- Vaporizing models

Contents

Features, 2

Operation, 3

Selection, 3

Testing, 4

Cleaning and Packaging, 4

Pressure-Reducing



**General-Purpose
(KPR Series), 6**



**Two-Stage
(KCY Series), 8**



**High-Sensitivity
(KLF Series), 10**



**High-Flow,
High-Sensitivity
(KHF Series), 12**



**Compact
(KCP Series), 14**



**Medium- to
High-Pressure
(KPP Series), 16**



**High-Flow
(KPF Series), 18**



**High-Pressure
(KHP Series), 20**



**High-Pressure
Hydraulic
(KHR Series), 22**

Back-Pressure



**General-Purpose
(KBP Series), 24**



**High-Flow,
High-Sensitivity
(KFB Series), 26**



**Compact
(KCB Series), 28**



**Medium- to
High-Pressure
(KPB Series), 30**



**High-Pressure
(KHB Series), 32**

Specialty Pressure-Reducing



**Gas Cylinder
Changeover
(KCM Series), 34**



**Steam-Heated
Vaporizing
(KSV Series), 36**



**Electrically Heated
Vaporizing
(KEV Series), 38**

Flow Data

Pressure-Reducing Regulators, 41

Back-Pressure Regulators, 49

Port Configurations, 52

Options and Accessories, 53

Maintenance Kits, 56

General-Purpose Diaphragm-Sensing Back-Pressure Regulators (KBP Series)

The KBP series is a high-sensitivity, general-purpose regulator designed to control back-pressure levels in analytical or process systems upstream of the regulator. The convoluted diaphragm provides excellent sensitivity and set-point repeatability. The metal-to-metal diaphragm seal minimizes the potential for leakage.

Features

- Convoluted, nonperforated diaphragm
- Metal-to-metal diaphragm seal
- Low internal volume
- Two-piece cap design provides linear load on the seal

Technical Data

Maximum Inlet Pressure

- Equal to pressure control range

Pressure Control Ranges

- 0 to 10 psig (0.68 bar) through 0 to 500 psig (34.4 bar)

Flow Coefficient (C_v)

- 0.20
- See page 49 for flow graphs.*

Maximum Operating Temperature

- 176°F (80°C) with PCTFE retainer seal
- 392°F (200°C) with PEEK retainer seal

Weight

- 2.4 lb (1.1 kg)

Ports

- 1/4 in. female NPT inlet, outlet, and gauge ports (all body materials)
- 1/4 in. tube butt weld inlet, outlet, and gauge ports (316 SS body material only)
- 1/4 in. VCR inlet, outlet, and gauge ports (316 SS body material only)



Materials of Construction

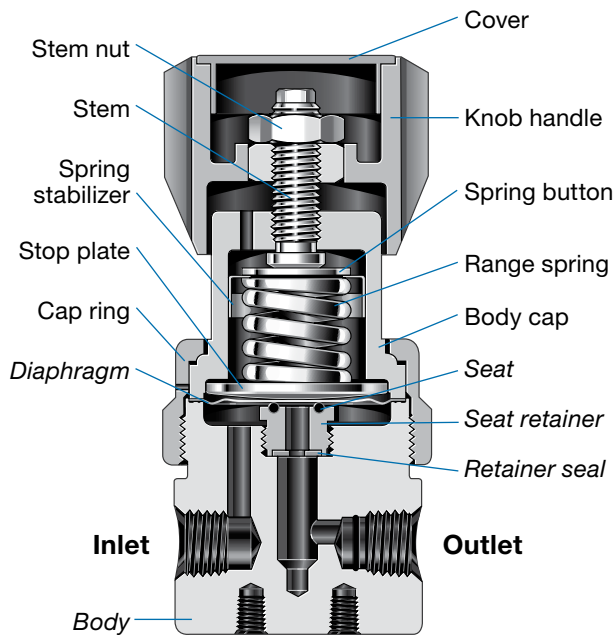

Component	316 SS	Brass CW721R
	Material	
Knob handle, cover	Nylon with 316 SS insert	
Spring button	316 SS (0 to 500 psig range) Zinc-plated steel (all other ranges)	
Spring stabilizer ^①	301 SS	
Range spring	316 SS (0 to 10 through 0 to 50 psig control ranges) Zinc-plated steel (0 to 100 through 0 to 500 psig control ranges)	
Stem, stem nut, cap ring, stop plate, body cap, panel nuts ^②	316 SS	
VCR nuts ^②	316 SS	—
Nonwetted lubricant	Hydrocarbon-based	
Seat retainer	316 SS	
Retainer seal	PCTFE or PEEK	
Seat	Fluorocarbon FKM or Kalrez	
Diaphragm ^③	Alloy X-750	
Body	316 SS	Brass CW721R
Tube butt weld ports, ^② VCR gland ports ^②	316L SS	—
Wetted lubricant	PTFE-based	

Wetted components listed in *italics*.

① Not included in regulators with 0 to 500 psig (0 to 34.4 bar) control range.

② Not shown.

③ Regulators with control ranges higher than 0 to 100 psig (0 to 6.8 bar) are assembled with two diaphragms.

Dimensions

Dimensions, in inches (millimeters), are for reference only and are subject to change.

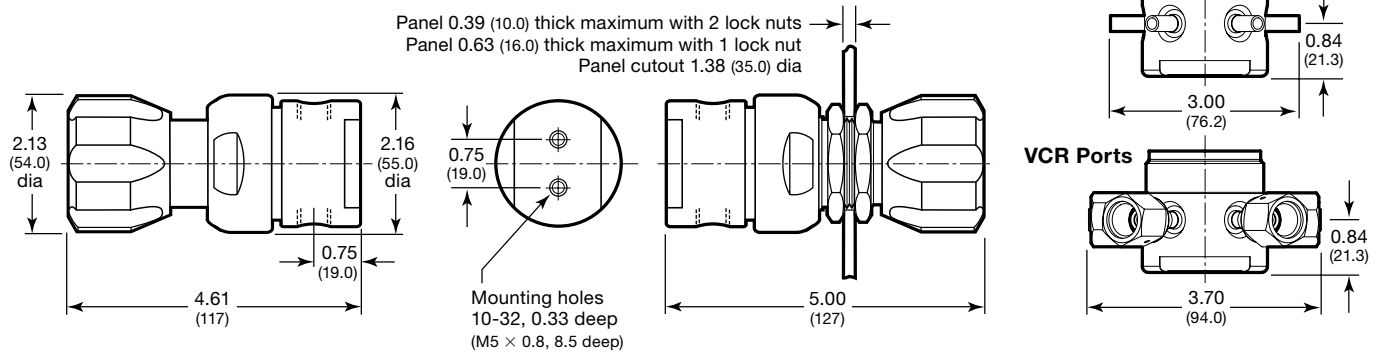

Ordering Information

Build a KBP series regulator ordering number by combining the designators in the sequence shown below.

4 **5** **6** **7** **8** **9** **10** **11** **12** **13** **14** **15** **16**
 KBP 1 F 0 D 4 A 5 A 2 0 0 0 0

4 Body Material

- 1 = 316 SS
- 2 = Brass CW721R
- A = 316 SS, ASTM G93 Level E-cleaned
- B = Brass, ASTM G93 Level E-cleaned
- C = 316 SS, SC-11-cleaned
- D = Brass, SC-11-cleaned

5 Pressure Control Range

- C = 0 to 10 psig (0 to 0.68 bar)
- D = 0 to 25 psig (0 to 1.7 bar)
- E = 0 to 50 psig (0 to 3.4 bar)
- F = 0 to 100 psig (0 to 6.8 bar)
- G = 0 to 250 psig (0 to 17.2 bar)
- J = 0 to 500 psig (0 to 34.4 bar)

6 Maximum Inlet Pressure

- 0 = Not applicable (equal to pressure control range)

7 Port Configuration

- A, D, G, V
- See *Port Configurations*, page 52.

8 Ports

- 4 = 1/4 in. female NPT
- T = 1/4 in. × 0.035 in. tube butt weld^①
- V = 1/4 in. VCR gland, no nuts^{①②}
- X = 1/4 in. rotatable female VCR fitting^①
- Y = 1/4 in. rotatable male VCR fitting^①

^① Available only with 316 SS body material in A port configuration. Not available ASTM G93 Level E-cleaned.

^② For use with VCR split-nuts, which can be ordered separately. See the Swagelok *VCR Metal Gasket Face Seal Fittings* catalog, MS-01-24.

9 Seat, Seal Material

- A = Fluorocarbon FKM, PCTFE
- B = Kalrez, PCTFE
- C = Fluorocarbon FKM, PEEK
- D = Kalrez, PEEK

10 Flow Coefficient (C_v)

- 5 = 0.20

11 Sensing Mechanism, Vent

- A = Alloy X-750 diaphragm, no vent
- E = Alloy X-750 diaphragm, captured vent, no self vent

12 Handle, Mounting

- 2 = Knob
- 3 = 316 SS antitamper nut
- 6 = Knob, panel mount
- 7 = 316 SS antitamper nut, panel mount

For knob handle color options, see page 56.

13 Valves

- 0 = No valves

14 Cylinder Connections

- 0 = No connections

15 Gauges

- 0 = No gauges
- For inlet gauge options, see page 54.

16 Options

- 0 = No options