

Pressure Regulators K Series



- Pressure-reducing models
- Back-pressure models
- Gas cylinder changeover model
- Vaporizing models

Contents

- Features, 2
- Operation, 3
- Selection, 3
- Testing, 4
- Cleaning and Packaging, 4

Pressure-Reducing



**General-Purpose
(KPR Series), 6**



**Two-Stage
(KCY Series), 8**



**High-Sensitivity
(KLF Series), 10**



**High-Flow,
High-Sensitivity
(KHF Series), 12**



**Compact
(KCP Series), 14**



**Medium- to
High-Pressure
(KPP Series), 16**



**High-Flow
(KPF Series), 18**



**High-Pressure
(KHP Series), 20**



**High-Pressure
Hydraulic
(KHR Series), 22**

Back-Pressure



**General-Purpose
(KBP Series), 24**



**High-Flow,
High-Sensitivity
(KFB Series), 26**



**Compact
(KCB Series), 28**



**Medium- to
High-Pressure
(KPB Series), 30**



**High-Pressure
(KHB Series), 32**

Specialty Pressure-Reducing



**Gas Cylinder
Changeover
(KCM Series), 34**



**Steam-Heated
Vaporizing
(KSV Series), 36**



**Electrically Heated
Vaporizing
(KEV Series), 38**

Flow Data

- Pressure-Reducing Regulators, 41
- Back-Pressure Regulators, 49

Port Configurations, 52

Options and Accessories, 53

Maintenance Kits, 56

General-Purpose Diaphragm-Sensing, Pressure-Reducing Regulators (KPR Series)

The KPR series is a compact regulator with excellent accuracy, sensitivity, and set-point pressure stability.

Features

- Convoluted, nonperforated diaphragm
- Metal-to-metal diaphragm seal
- Low internal volume
- Two-piece cap design provides linear load on the diaphragm seal
- High-flow, dual-gauze type filter positively retained in inlet port

Technical Data

Maximum Inlet Pressure

- 3600 psig (248 bar)
- 6000 psig (413 bar) with PEEK seat

Pressure Control Ranges

- 0 to 10 psig (0.68 bar) through 0 to 500 psig (34.4 bar)

Flow Coefficient (C_v)

- 0.06 and 0.20
See page 41 for flow graphs.
- 0.02 and 0.50 also available

Supply-Pressure Effect

| Flow Coefficient (C _v) | Pressure Control Range | |
|------------------------------------|---------------------------|--------------------------------|
| | Up to 100 psig (6.8 bar) | 250 psig (17.2 bar) and Higher |
| | Supply Pressure Effect, % | |
| 0.02 | 0.3 | 0.5 |
| 0.06 | 1.0 | 1.5 |
| 0.20 | 1.7 | 2.5 |
| 0.50 | 2.3 | 3.3 |

Maximum Operating Temperature

- 176°F (80°C) with PCTFE seat
- 392°F (200°C) with PEEK seat
- 212°F (100°C) with PEEK seat and maximum inlet pressure greater than 3600 psig (248 bar)

Weight

- 2.4 lb (1.1 kg)



Ports

- 1/4 in. female NPT inlet, outlet, and gauge ports (all body materials)
- 1/4 in. tube butt weld inlet, outlet, and gauge ports (316 SS body material only)
- 1/4 in. VCR® inlet, outlet, and gauge ports (316 SS body material only)

Materials of Construction

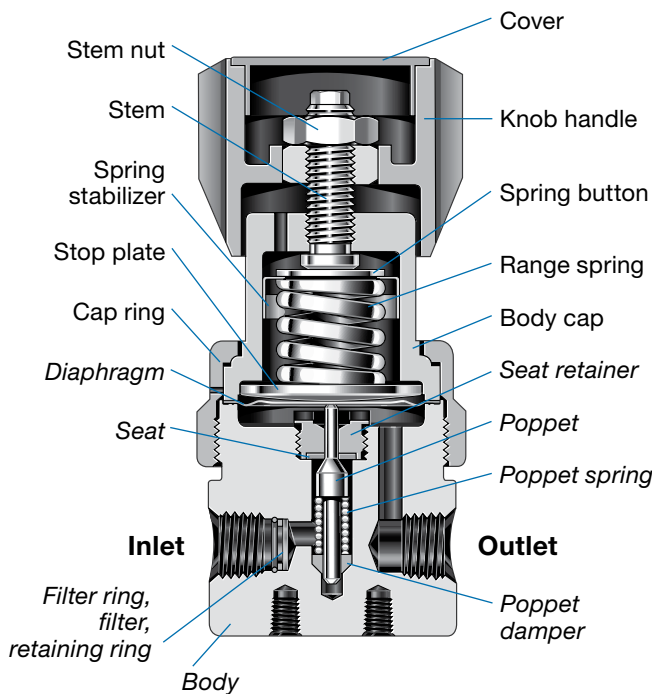

| Component | 316 SS | Brass CW721R | Alloy 400 | Alloy C-276 |
|---|---|--------------|-----------|-------------|
| | Material | | | |
| Knob handle, cover | Nylon with 316 SS insert | | | |
| Spring button | Zinc-plated steel | | | |
| Spring stabilizer ^① | 301 SS | | | |
| Range spring | 316 SS or zinc-plated steel, depending on configuration | | | |
| Stem, stem nut, cap ring, stop plate, body cap, panel nuts ^② | 316 SS | | | |
| VCR nuts ^② | 316 SS | — | | |
| Nonwetted lubricant | Hydrocarbon-based | | | |
| Seat retainer | 316 SS | Alloy 400 | | Alloy C-276 |
| Seat | PCTFE or PEEK | | | |
| Filter, retaining ring | 316 SS | Alloy C-22 | | |
| Diaphragm ^③ | Alloy X-750 or alloy C-276 | | | |
| Poppet | S17400 SS | Alloy 400 | | Alloy C-276 |
| Poppet spring | Alloy X-750 | | | Alloy C-276 |
| Poppet damper, filter ring | PTFE | | | |
| Self-vent seal ^② | Fluorocarbon FKM | | — | |
| Body | 316 SS | Brass CW721R | Alloy 400 | Alloy C-276 |
| Tube butt weld ports, ^② VCR gland ports ^② | 316L SS | — | | |
| Wetted lubricant | PTFE-based | | | |

Wetted components listed in *italics*.

① Not required in all configurations.

② Not shown.

③ Regulators with control ranges higher than 0 to 100 psig (0 to 6.8 bar) are assembled with two diaphragms.

Dimensions

Dimensions, in inches (millimeters), are for reference only and are subject to change.

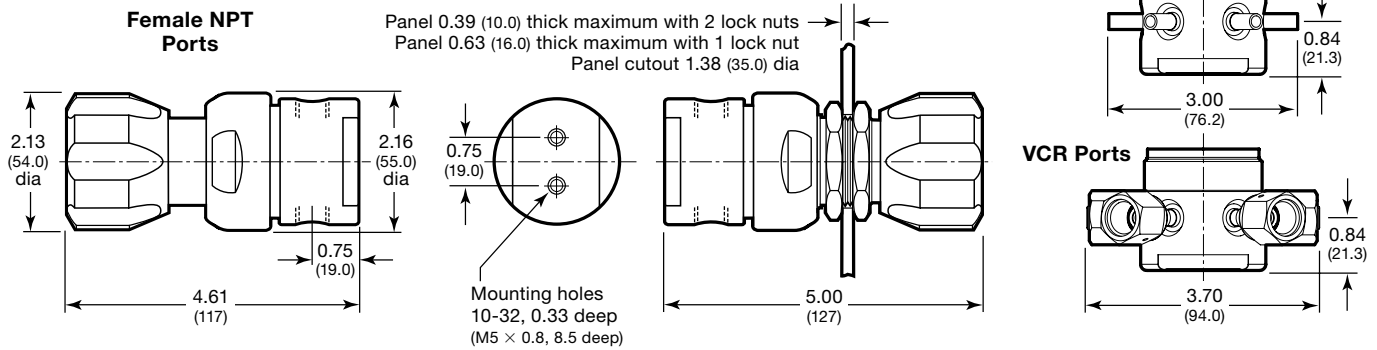

Ordering Information

Build a KPR series regulator ordering number by combining the designators in the sequence shown below.

4 5 6 7 8 9 10 11 12 13 14 15 16
KPR 1 F R F 4 1 2 A 2 0 0 0 0

4 Body Material

- 1 = 316 SS
- 2 = Brass CW721R
- 4 = Alloy 400
- 5 = Alloy C-276
- A = 316 SS, ASTM G93 Level E-cleaned
- B = Brass, ASTM G93 Level E-cleaned
- C = 316 SS, SC-11-cleaned
- D = Brass, SC-11-cleaned

5 Pressure Control Range

- C = 0 to 10 psig (0 to 0.68 bar)^①
- D = 0 to 25 psig (0 to 1.7 bar)^①
- E = 0 to 50 psig (0 to 3.4 bar)
- F = 0 to 100 psig (0 to 6.8 bar)
- G = 0 to 250 psig (0 to 17.2 bar)
- J = 0 to 500 psig (0 to 34.4 bar)

① Select 0.02 or 0.06 flow coefficient if maximum inlet pressure is 4351 psig (300 bar) or 6000 psig (413 bar).

6 Maximum Inlet Pressure^①

- F = 100 psig (6.8 bar)
- J = 500 psig (34.4 bar)
- L = 1000 psig (68.9 bar)
- P = 3000 psig (206 bar)^②
- R = 3600 psig (248 bar)^③
- T = 4351 psig (300 bar)^{③④}
- W = 6000 psig (413 bar)^{③④⑤}

- ① For better resolution and control, select a pressure that closely matches system pressure.
- ② Available for regulators assembled with CGA cylinder connection or inlet hose only.
- ③ Not available for regulators assembled with CGA cylinder connection or inlet hose.
- ④ Available only with 316 SS body material and PEEK seat material. Not available with SC-11 cleaning.
- ⑤ Not available for regulators assembled with isolation valves.

7 Port Configuration

A, B, C, E, F, H, K, L, M, N

See **Port Configurations**, page 52.

8 Ports

- 4 = 1/4 in. female NPT
- T = 1/4 in. × 0.035 in. tube butt weld^①
- V = 1/4 in. VCR gland, no nuts^{①②}
- X = 1/4 in. rotatable female VCR fitting^①
- Y = 1/4 in. rotatable male VCR fitting^①

① Available only with 316 SS body material in A and F port configurations; does not contain a filter. Not available with maximum inlet pressure greater than 3600 psig (248 bar). Not available ASTM G93 Level E-cleaned.

② For use with VCR split-nuts, which can be ordered separately. See the Swagelok *VCR Metal Gasket Face Seal Fittings* catalog, MS-01-24.

9 Seat Material

- 1 = PCTFE
- 2 = PEEK

10 Flow Coefficient (C_v)

- 1 = 0.02 5 = 0.20
- 2 = 0.06 7 = 0.50

11 Sensing Mechanism, Vent

- A = Alloy X-750 diaphragm, no vent
- C = Alloy X-750 diaphragm, self vent^①
- E = Alloy X-750 diaphragm, captured vent, no self vent
- F = Alloy X-750 diaphragm, self and captured vent^①
- H = Alloy C-276 diaphragm, no vent

① Available only with 316 SS and brass body materials and 0.06 and 0.20 C_v.

12 Handle, Mounting

- 2 = Knob
- 3 = 316 SS antitamper nut
- 6 = Knob, panel mount
- 7 = 316 SS antitamper nut, panel mount

For knob handle color options, see page 56.

13 Isolation and Relief Valves

- 0 = No valves

For isolation and relief valve options, see page 54.

14 Cylinder Connections

- 0 = No connections

For CGA cylinder connection options, see page 53.

15 Gauges

- 0 = No gauges

For inlet and outlet gauge options, see page 54.

16 Options

- 0 = No options
- H = Inboard helium leak test to a maximum leak rate of 1×10^{-5} std cm³/s^①
- 3 = 3 ft, 1/4 in. FM series metal flexible hose, 1/4 in. female NPT inlet^②
- 4 = 3 ft, 1/4 in. TH series PTFE-lined, stainless steel braided hose, 1/4 in. female NPT inlet^②

For more information about hoses, see page 56.

① Not available with self vent.

② Not available for ASTM G93 Level E-cleaned and SC-11 cleaned regulators.

Select KPR series regulators are available that meet the testing requirements of ASTM G175, "Standard Test Method for Evaluating the Ignition Sensitivity and Fault Tolerance of Oxygen Regulators Used for Medical and Emergency Applications." Contact your authorized Swagelok sales and service representative.