

BASIC WIRING

[CLICK ON DESIRED PAGE](#)

Electrical Circuits	2
Types of Electrical Switches	3
Switch Operation	4
LWCO and Feeder Wiring	
<i>Standard Combinations</i>	6
LWCO Wiring	
<i>RB-24</i>	11
<i>RB-122</i>	12
High Water Alarm (using Series 750 controls)	13
Level Control	14

Electrical Circuits

Many McDonnell & Miller products are used to switch electrical circuits, in response to physical parameters such as level and flow. Understanding electrical wiring is necessary to ensure proper installation and operation.

Therefore, we are providing you with this Basic Wiring section as primary information on electric circuits and switches, and how to wire popular McDonnell & Miller products.

WARNING	
	To prevent an electrical fire, equipment damage, or electrocution, follow electrical wiring instructions, codes and ordinances.
	Failure to follow this warning could cause property damage, personal injury or death.

Series

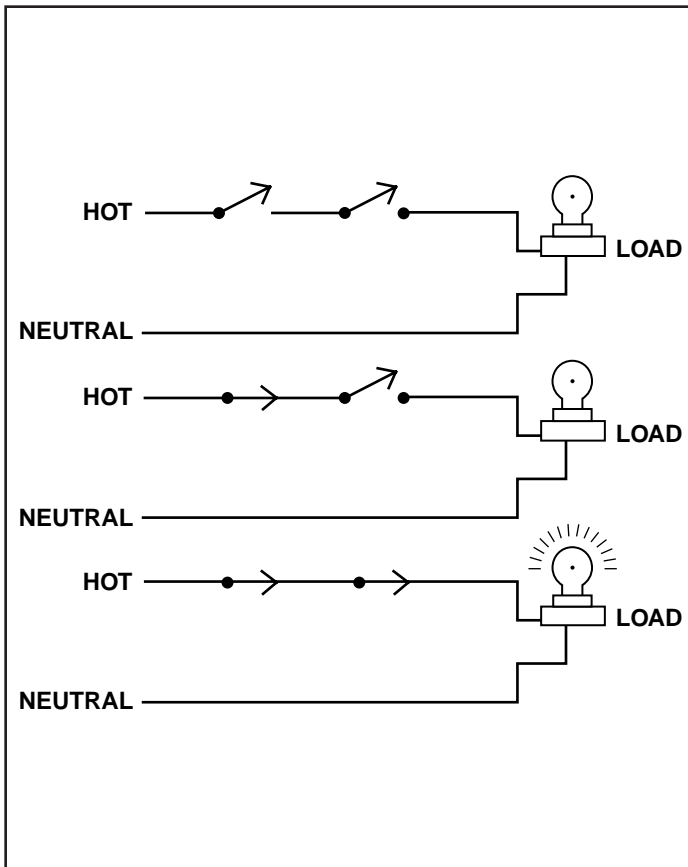

**Both closed, circuit closed.
One open, circuit open.**

Parallel

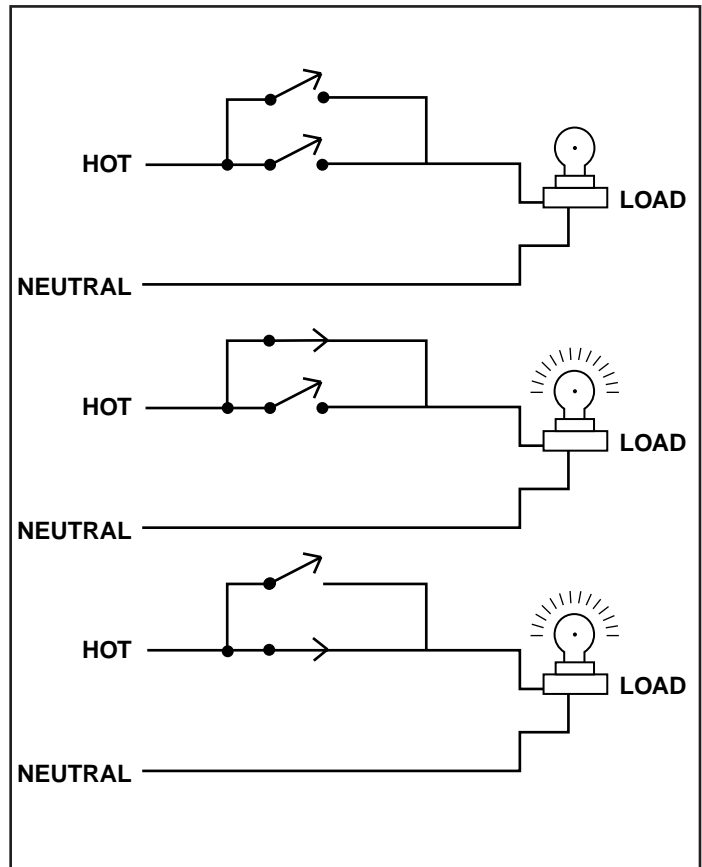

**One closed, circuit closed.
Both open, circuit open.**

Types of Electrical Switches

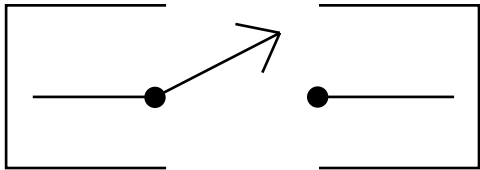
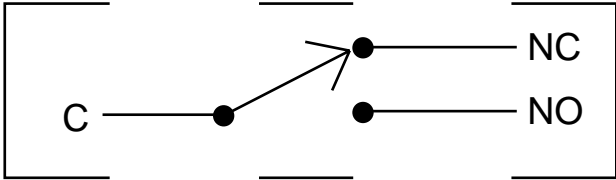
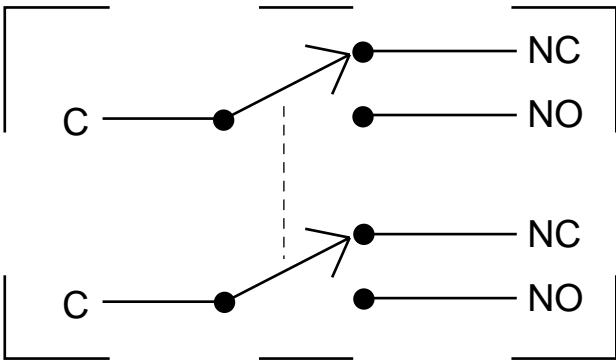
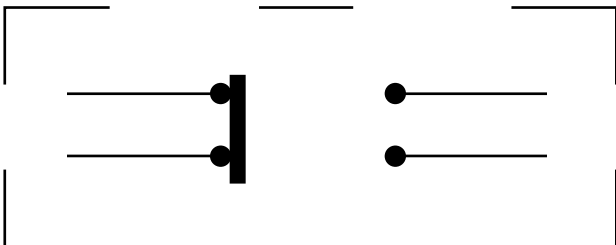
Type	Description	Where Used
 <p data-bbox="261 569 613 625">SPST (Single Pole, Single Throw)</p>	<p>Make or break one circuit.</p>	<p>Series 65, 150, 150S & 165 boiler control pump switch Series 11 switch</p>
 <p data-bbox="256 957 618 1014">SPDT (Single Pole, Double Throw)</p>	<p>Make one circuit and break one circuit with common terminal.</p>	<p>Series 2 switch Series 150 boiler control burner switch & alarm All flow switches</p>
 <p data-bbox="256 1503 618 1560">DPDT (Double Pole, Double Throw)</p>	<p>Make two circuits and break two circuits with two common terminals.</p>	<p>Series FS7-4D flow switch Series FS4-3D flow switch Series AF3-D flow switch Series FS5-D flow switch</p>
 <p data-bbox="261 1934 613 1990">SPDB (Single Pole, Double Break)</p>	<p>Make one circuit and break one circuit with no common terminals.</p>	<p>Series 5 & 6 switches E-28 Level Control E-27 Switch</p>

Switch Operation

No. 2 Switch
 Used on McDonnell No. 47-2, No. 247-2, No. 51-2, No. 51-S-2, No. 53-2 and No. 63

Water level normal. Burner on—alarm off.

Low water level. Burner off—alarm on.

No. 11 Switch
 Used on McDonnell No. 64, No. 67, No. 61 and all "Built-in" type Low Water Cut-offs.

Water level normal. Burner on—electric feed valve or alarm off.

Water level dropped to electric feed valve or alarm operating level. Burner on.

Low water level. Burner off—electric feed valve or alarm on.

Series 150 & 150S Switch
 Used on No. 150 and 157 Series.

At Normal Operating Level Boiler feed pump off—burner on—alarm off.

As Water Level Drops Boiler feed pump on—burner on—alarm off.

At Low Water Cut-Off Level Boiler feed pump on—burner off—alarm on.

No. 5 Switch
 Used on 93, 193, 94 and 194 Series.

At Normal Operating Level Boiler feed pump off—burner on—alarm off.

Boiler feed pump on—burner on—alarm off.

At Low Water Cut-Off Level Boiler feed pump on—burner off—alarm on.

LWCO & Water Feeder Wiring

STANDARD COMBINATIONS

These are suggested wiring diagrams but not the only solution to a particular installation. They cover different combinations of controls including different control voltages. Boiler manufacturers' wiring diagrams should be followed whenever possible.

Always follow local codes whenever selecting and installing a LWCO.

Note:

- The voltage of the feeder should be the same as the LWCO whenever possible
- An electric water feeder should never be connected to a manual reset LWCO
- The LWCO should always be wired first-in-line before any other operating or limit controls
- On PS units terminal "W" or "4" may also be used as a low water alarm connection instead of a feeder connection
- To avoid damage to a system with a Model 101A-24V feeder, transformer 101-24V-48, supplied with the unit, must be used
- The field jumper used for Series 67 units and older PS units with terminals 1 to 5 is not supplied by McDonnell & Miller

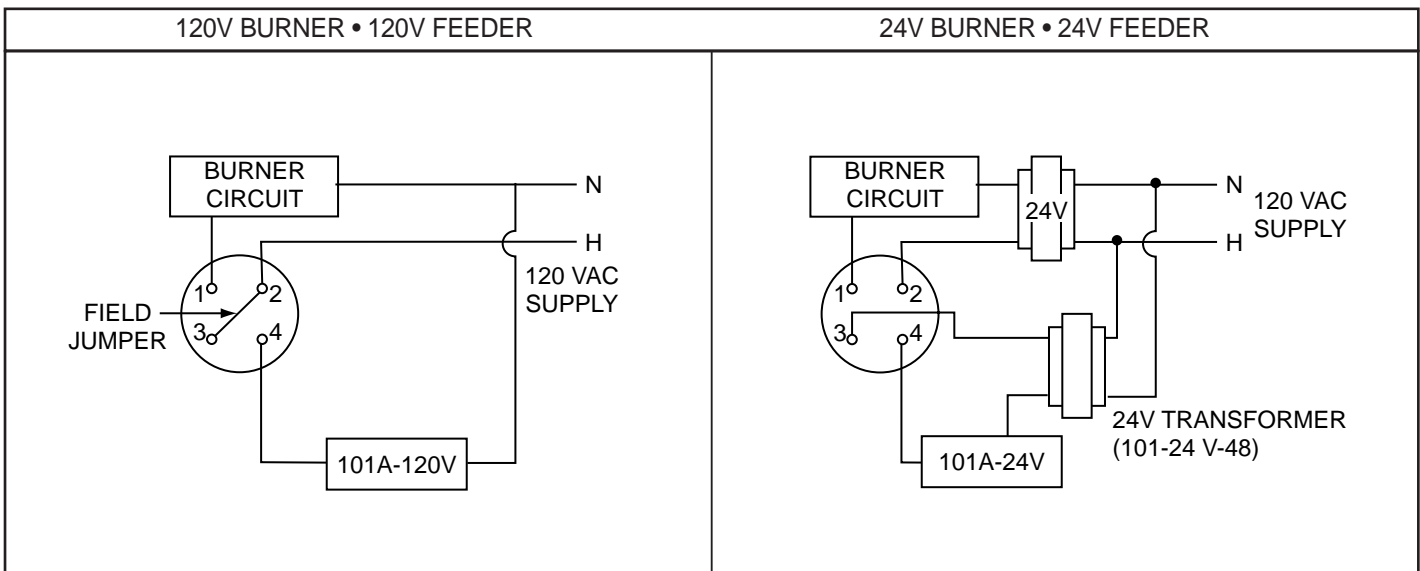
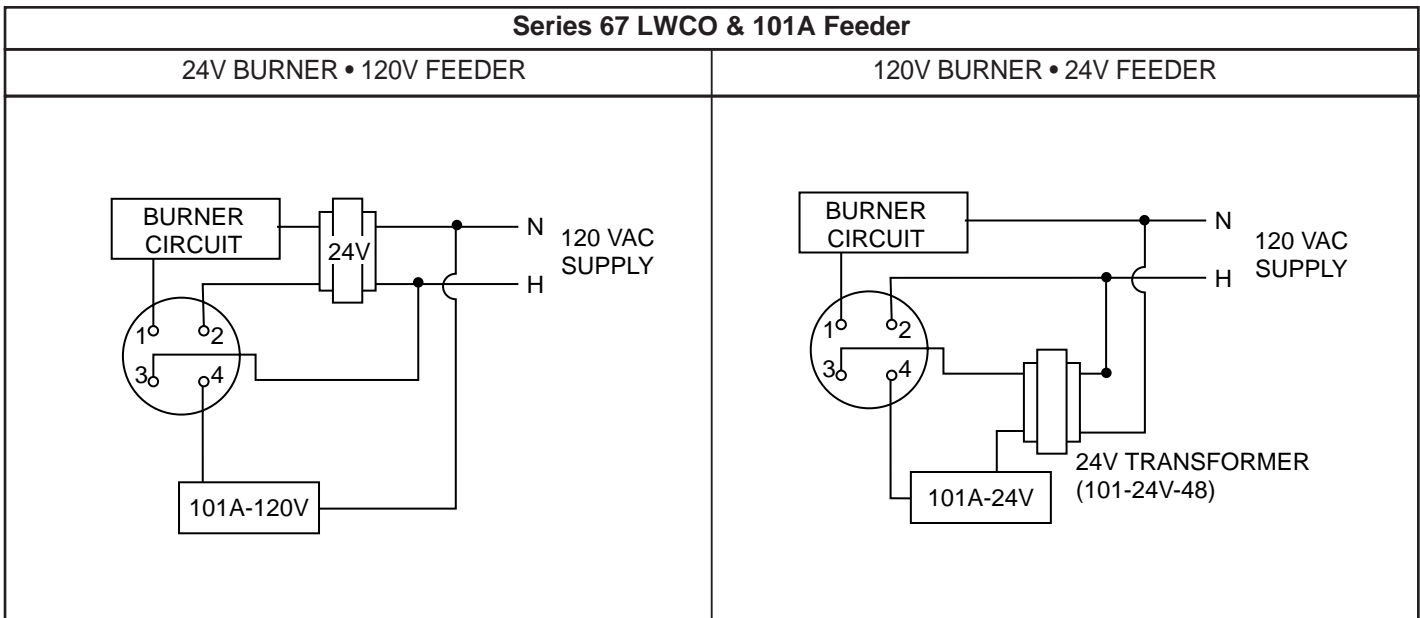

LWCO & Water Feeder Wiring

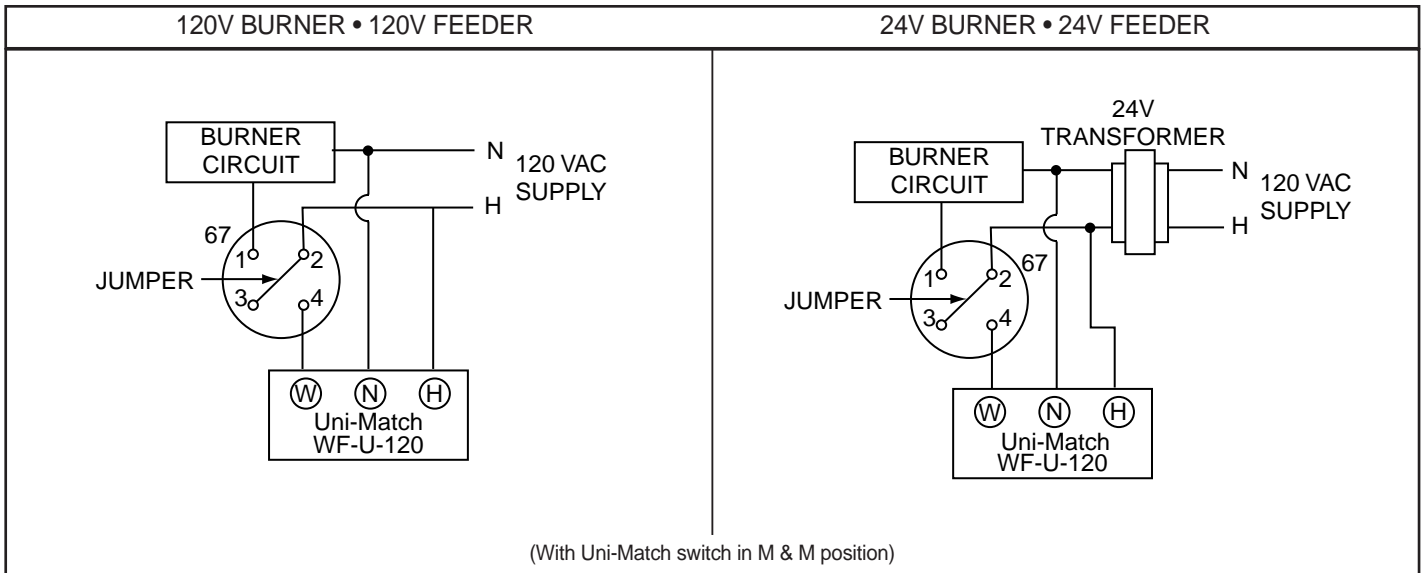
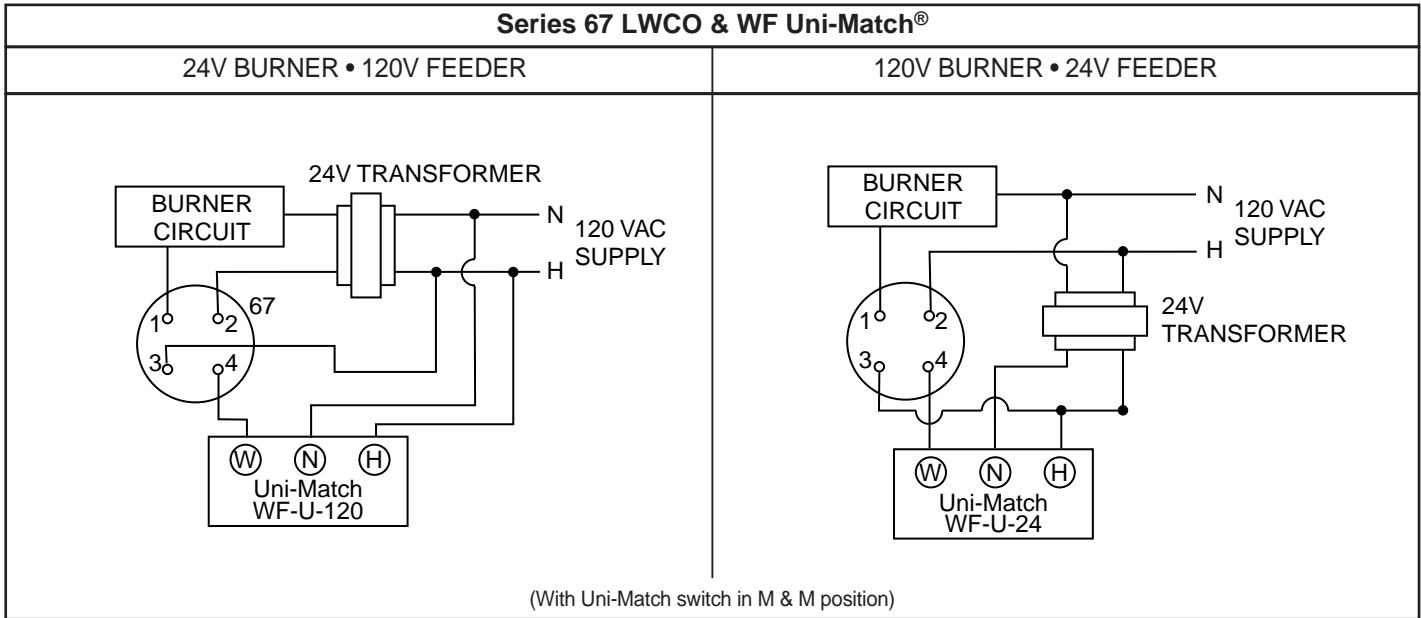

LWCO & Water Feeder Wiring

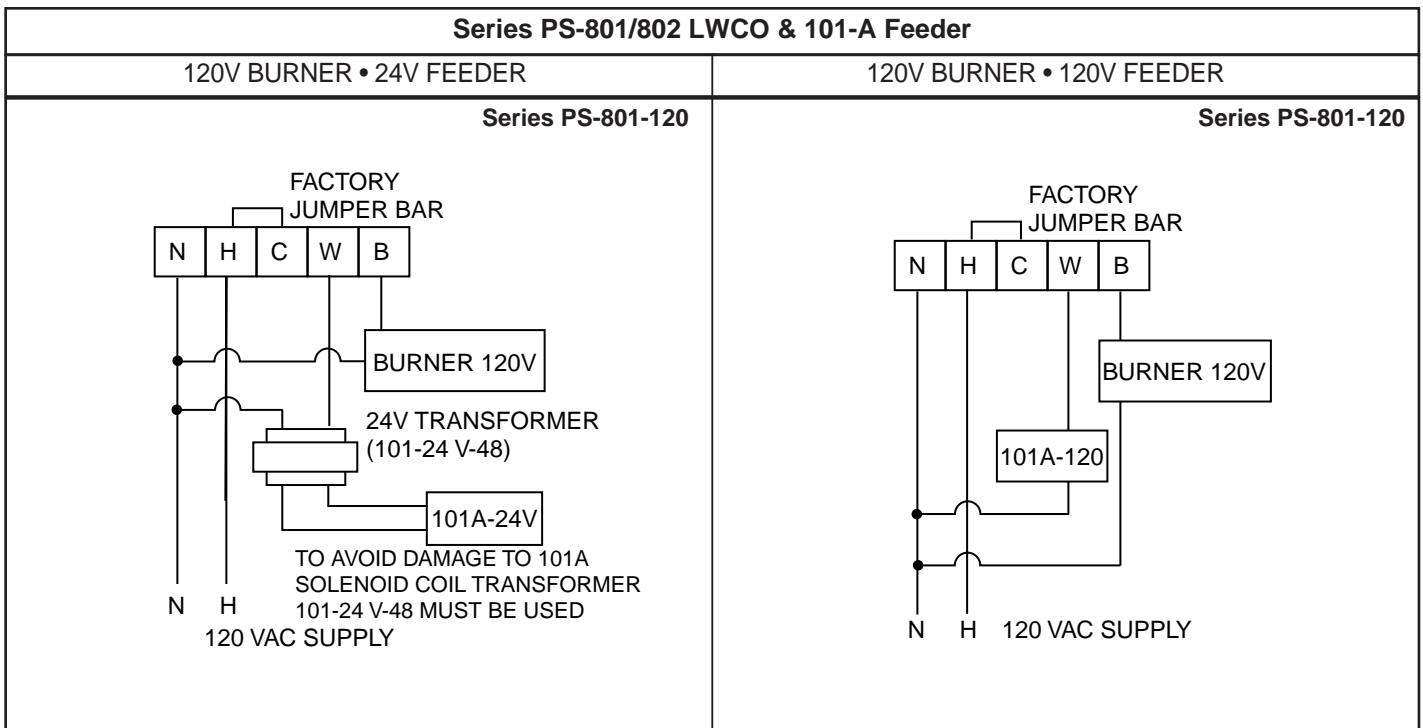
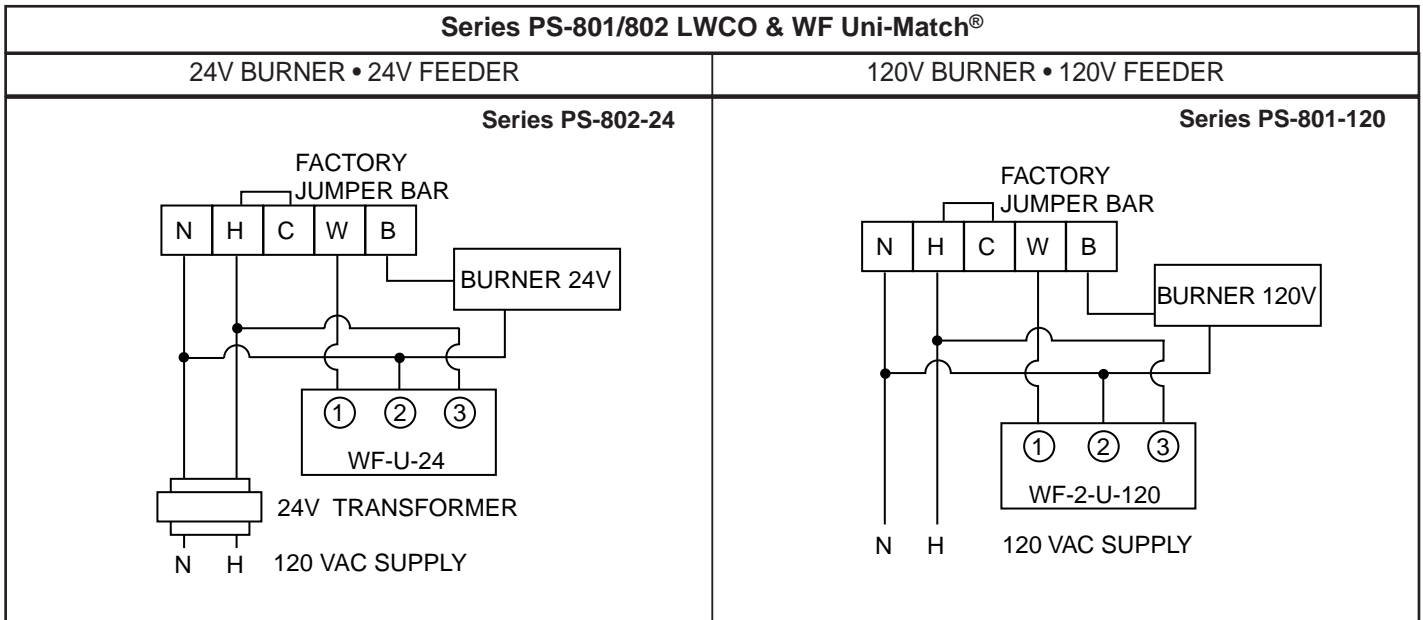

LWCO & Water Feeder Wiring

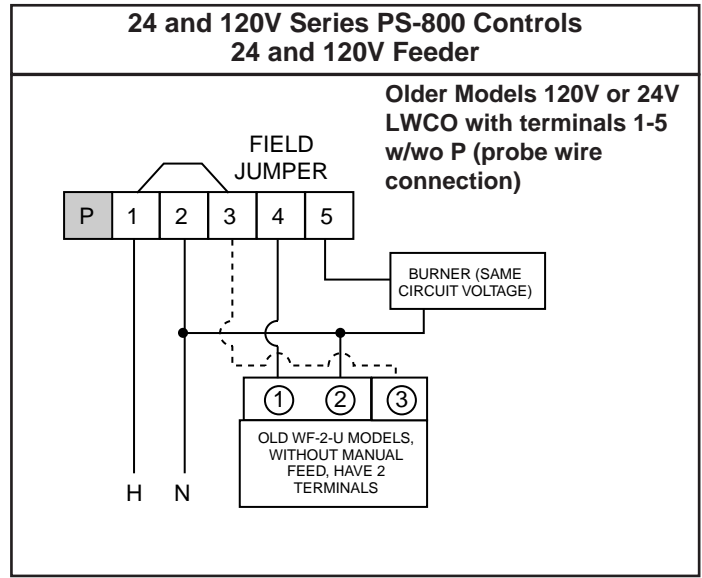
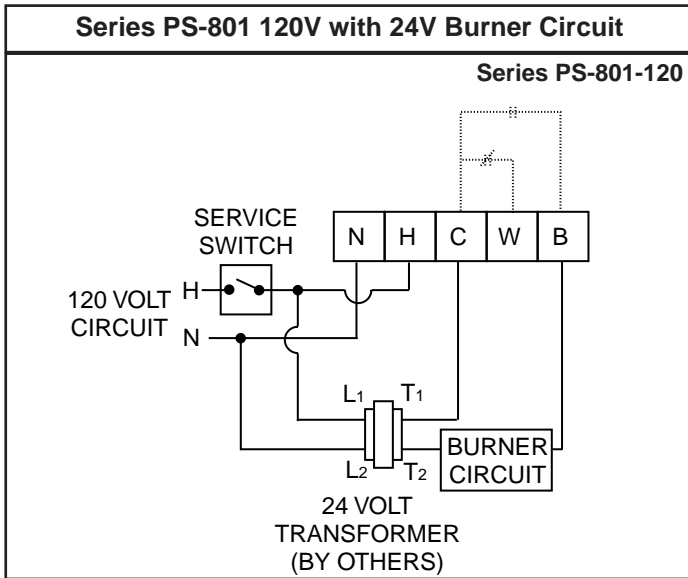
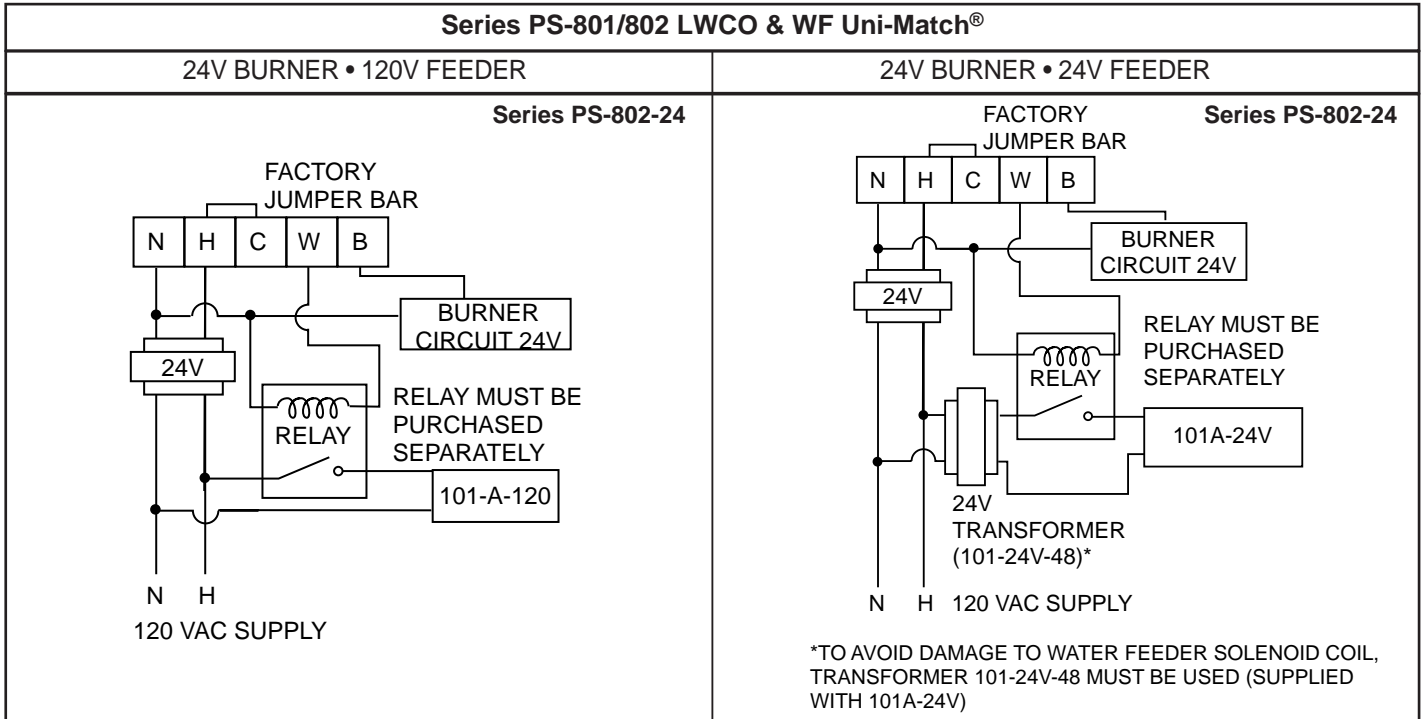

LWCO Wiring

RB-24

The RB-24 can be used on gas and oil fired boilers with 24 volt control circuit including boilers with spark ignition. The wiring diagrams show connecting the RB-24 on typical burner circuits. Note that the control requires a constant source of power with the red (hot) and white (neutral) wires connected directly to the transformer.

The yellow wires can be connected at the beginning of the burner circuit (Fig. 1) or in series (Fig. 2). In burner circuits utilizing relays, it is recommended to connect the RB-24 wires as shown in Fig. 3. This ensures there is enough current draw to hold in the triac circuit.

It is important to determine if the secondary side of the transformer is grounded. The instructions included with the control have a procedure to determine if the circuit is grounded. This is important because the RB-24 may not work if there is no ground on the secondary side of the transformer. If the secondary side of the transformer is already grounded and the ground wire on the RB-24 is grounded, a short across the transformer could occur.

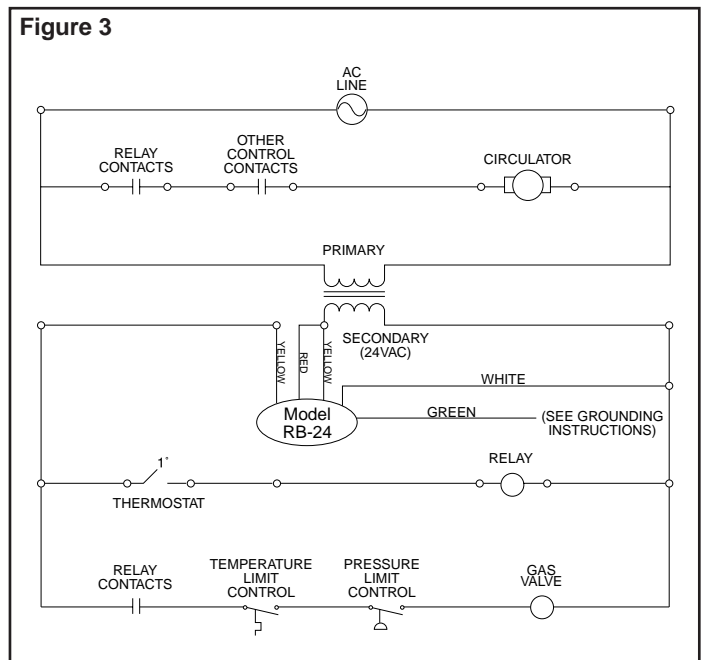
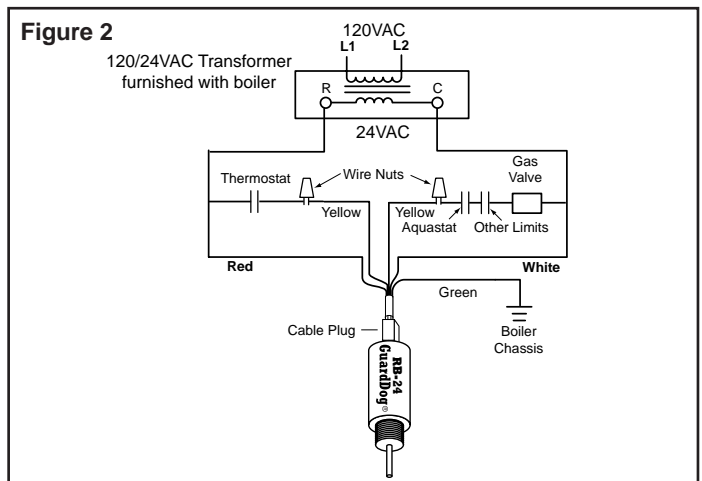
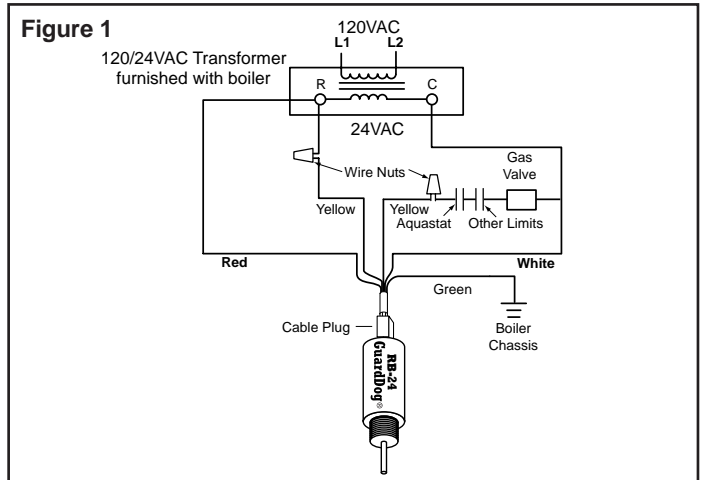

LWCO Wiring

RB-122

The RB-122 should be wired first-in-line when the control is installed on a new boiler. The control will require a constant source of 120 volt power which should be from the same circuit as the existing boilers' power source which is typically the service switch.

The following diagrams show how to wire a RB-122 for 120 volt and 24 volt burner circuits.

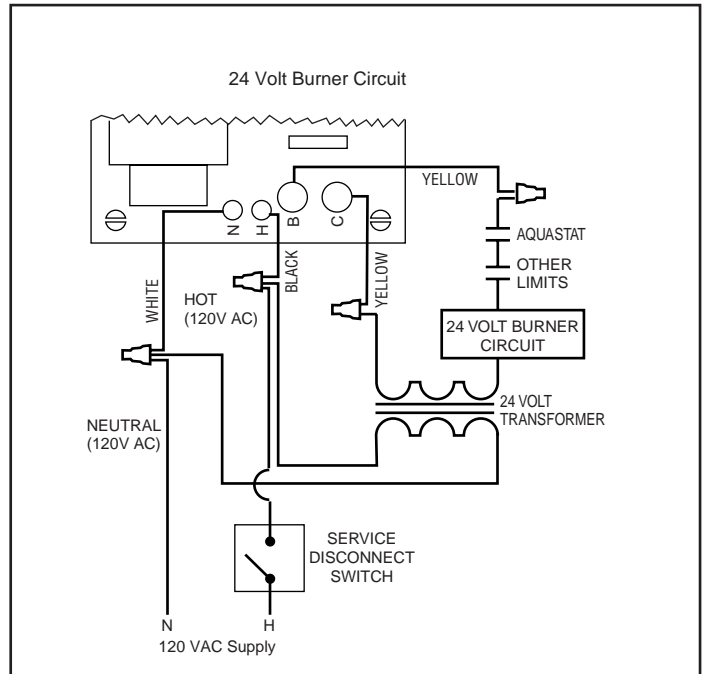
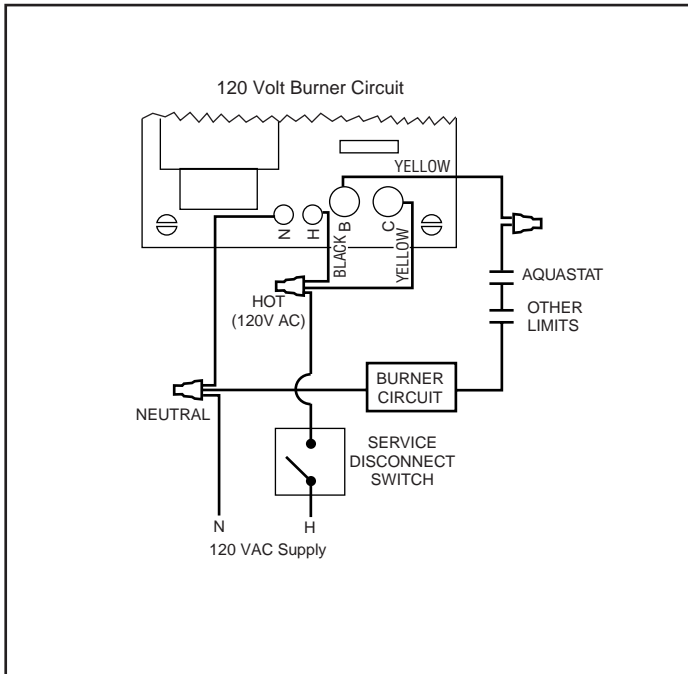

High Water Alarm using Series 750 Controls

A level control can be used to provide high water alarm, burner cut-off or pump cut-off on a boiler. Which control to select is dependent upon the existing boiler piping. The use of a Series 750 with a remote sensor can be added without additional piping or disturbing existing controls.

The 750 control box can be located near existing boiler wiring and the remote sensor located in an opening in the top of the boiler with probe cut to length. The control can be wired to do burner cut-off or alarm indication.

Items to remember when installing a 750 control for high water indication:

- Use a 750 T 120 (176206) for high alarm/cut-off applications.
- If used as a high water burner cut-off, the wiring must be in series with all other safety controls.
- The power for the control must be uninterrupted.
- The water level in the boiler should be visible in the sight glass at cut-off.
- Always follow boiler manufacturers' recommendations and local codes when installing a safety or level control.

Typical Installation

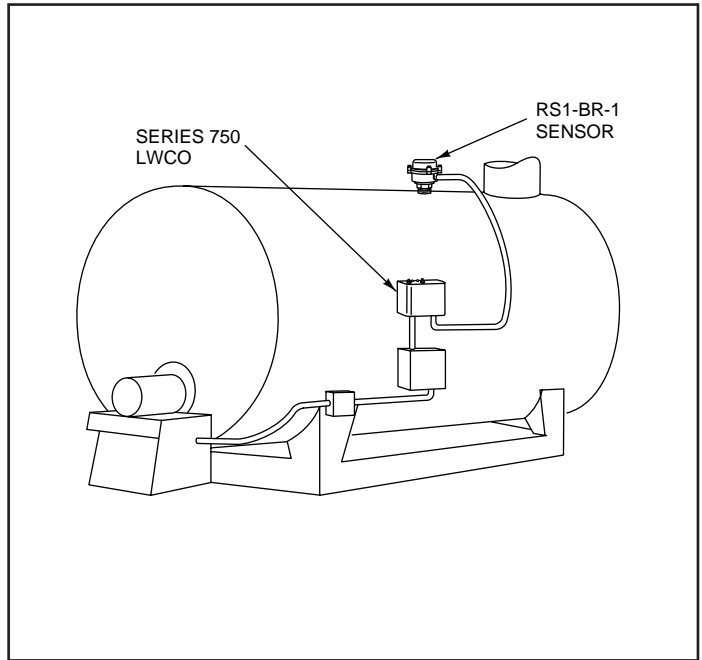

Typical Burner Cut-off Wiring

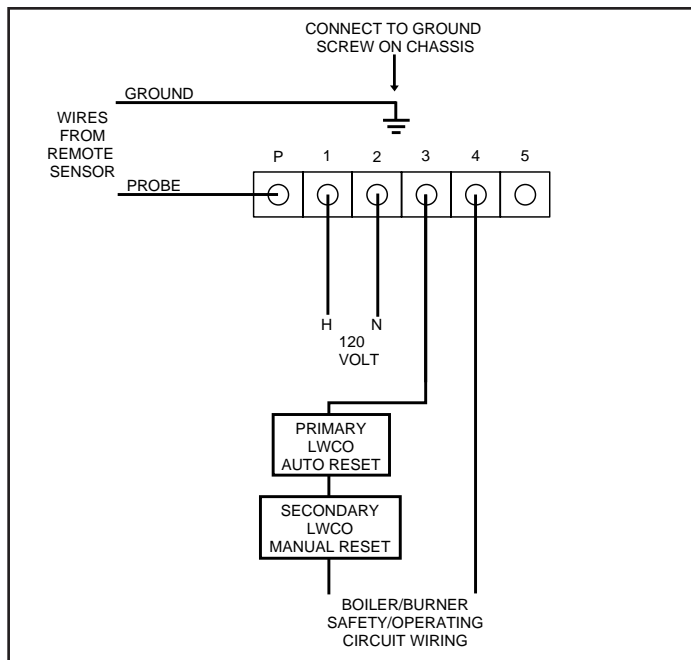

Typical Alarm Indication w/Holding Circuit

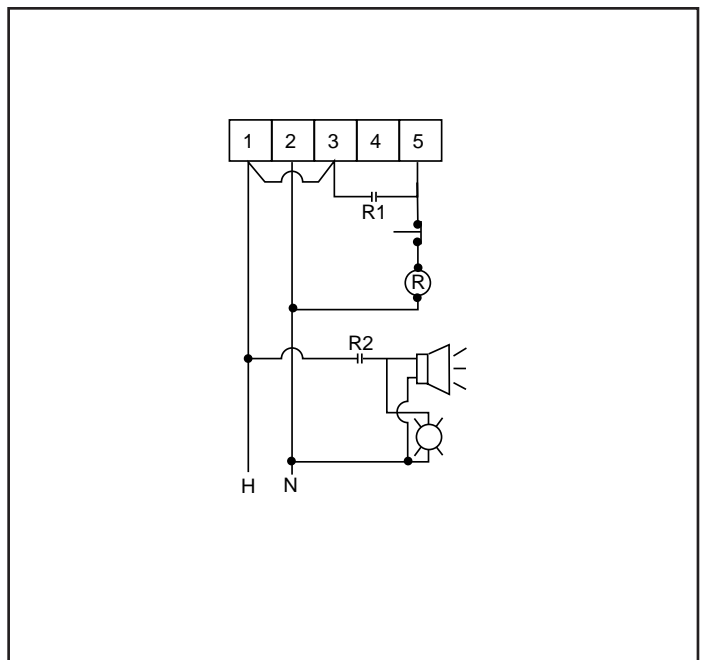

Level Control

While most controls are designed and marketed for use on boilers, they can be used in other applications. Any control, or pair of controls, can be used as a high alarm, low alarm or to maintain a level in a tank. Float controls, such as the 150, 61, 63 or 64, can be mounted on an equalizing pipe. Electronic controls, such as the PS-850, 750 or RB-120, can be mounted directly on the tank or vessel. Typical applications would be deaerators (high or low alarm only), condensate receivers or any other type of water storage tank.

Items to consider when selecting a control for this type of application:

- Use the alarm contacts when wiring the control to interrupt a circuit for high level cut-off.
- Use the burner contacts when wiring the control for high level alarm.

Maintaining Tank Level Utilizing Two Series 63 Controls

Typical Piping

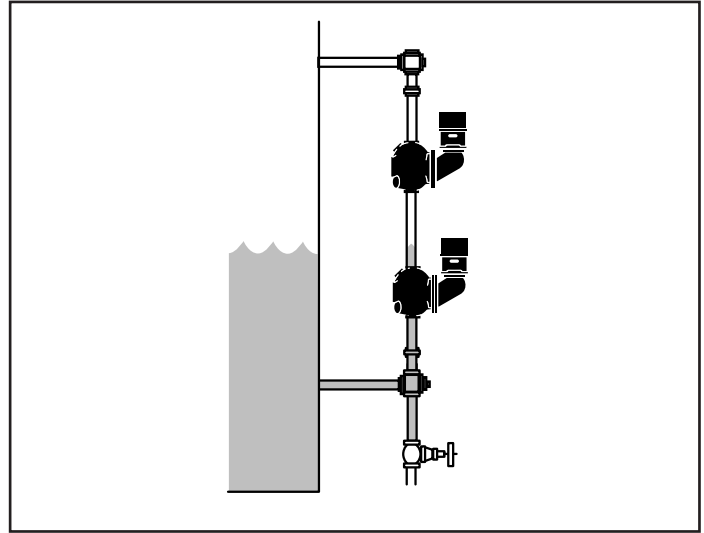

Typical Wiring for Tank Fill with a Pump

