

Lecture U Week 2: Linearization and Block Diagrams

Lecturer: Peyman Gohari

2.1 Linearization of nonlinear systems

Consider a nonlinear equation in two variables x and y :

$$f(x, y) = 0 \quad (2.1)$$

Let (x_0, y_0) be a pair of real numbers. Then $f(x, y)$ can be expanded into a Taylor series around (x_0, y_0) according to:

$$f(x, y) = f(x_0, y_0) + \frac{\partial f}{\partial x}\bigg|_{(x_0, y_0)}(x - x_0) + \frac{\partial f}{\partial y}\bigg|_{(x_0, y_0)}(y - y_0) + \frac{1}{2!} \frac{\partial^2 f}{\partial x^2}\bigg|_{(x_0, y_0)}(x - x_0)^2 + \frac{1}{2!} \frac{\partial^2 f}{\partial y^2}\bigg|_{(x_0, y_0)}(y - y_0)^2 + \dots$$

If (x_0, y_0) is a solution of (2.1), i.e. $f(x_0, y_0) = 0$, and assuming that variables x and y take values within a small neighborhood of x_0 and y_0 , respectively, then (2.1) can be simplified to the following linear approximation:

$$\frac{\partial f}{\partial x}\bigg|_{(x_0, y_0)}(x - x_0) + \frac{\partial f}{\partial y}\bigg|_{(x_0, y_0)}(y - y_0) \approx 0 \quad (2.2)$$

In future examples we use \approx and $=$ interchangeably.

Example 1 Consider the equation

$$y - x^2 = 0 \quad (2.3)$$

Note that $(x_0, y_0) = (1, 1)$ is a solution to (2.3). The linear approximation will be:

$$\begin{aligned} & \frac{\partial(y - x^2)}{\partial x}\bigg|_{(1,1)}(x - 1) + \frac{\partial(y - x^2)}{\partial y}\bigg|_{(1,1)}(y - 1) \approx 0 \\ \Leftrightarrow & (-2x)\big|_{(1,1)}(x - 1) + 1\big|_{(1,1)}(y - 1) \approx 0 \\ \Leftrightarrow & -2(x - 1) + (y - 1) \approx 0 \\ \Leftrightarrow & y \approx 2x - 1 \end{aligned}$$

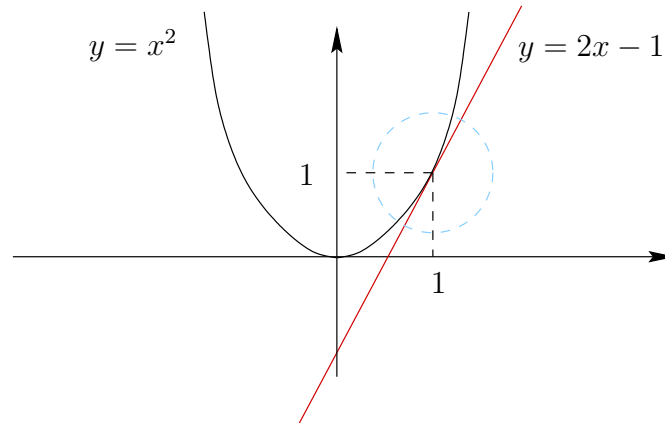

Figure 2.1: In the small neighborhood demarcated by the dashed-circle, $y = x^2$ behaves like $y \approx 2x - 1$.

The meaning of all this is that as shown in Figure 2.1, the *curve* $y = x^2$ can be approximated by the *straight line* $y \approx 2x - 1$ in a small neighborhood around $(1, 1)$.

□

To emphasize the fact that x and y take values in a small neighborhood around x_0 and y_0 , we write:

$$x =: x_0 + \delta x \quad \text{and} \quad y =: y_0 + \delta y.$$

Then (2.2) becomes

$$\frac{\partial f}{\partial x}|_{(x_0, y_0)} \delta x + \frac{\partial f}{\partial y}|_{(x_0, y_0)} \delta y \approx 0$$

Example 2 Back to Example 1, the linear approximation of $y = x^2$ around $(1, 1)$ is $\delta y = 2\delta x$. This is the same straight line (i.e. $y = 2x - 1$) rewritten around a new coordinate with origin located at $(1, 1)$. See Figure 2.2. □

We generalize the above result in three different directions.

1. The result is equally valid for nonlinear functions of more than two variables. For example, let $f(x, y, z) = 0$ be a nonlinear equation with a given solution (x_0, y_0, z_0) . Then in a small neighborhood around (x_0, y_0, z_0) the nonlinear equation can be approximated by

$$\frac{\partial f}{\partial x}|_{(x_0, y_0, z_0)} \delta x + \frac{\partial f}{\partial y}|_{(x_0, y_0, z_0)} \delta y + \frac{\partial f}{\partial z}|_{(x_0, y_0, z_0)} \delta z \approx 0$$

where $\delta x := x - x_0$, $\delta y := y - y_0$, and $\delta z := z - z_0$. In case of three variables, one linearizes a 3-dimensional surface with a plane.

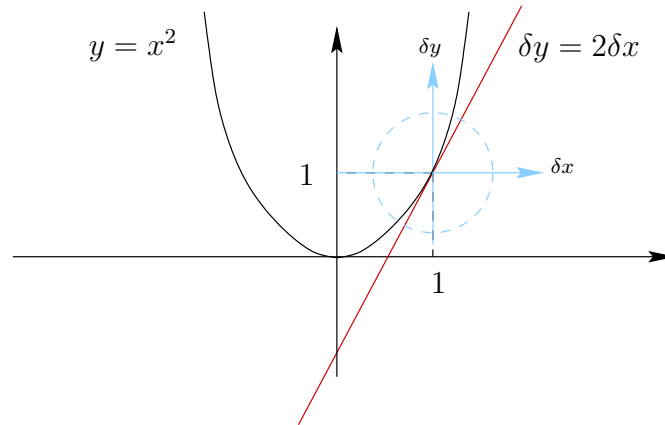

Figure 2.2: The straight line $\delta y = 2\delta x$ is the linear approximation of $y = x^2$.

- The variables x, y, z, \dots can be functions of time, or *signals*. Likewise, the solution of the equation x_0, y_0, z_0, \dots can be signals as well. They together are called the *operating point* of the system.

Example 3 Linearize the nonlinear equation

$$(t+1)y(t) - tx^2(t) = 0$$

around the operating point $x_0(t) = t+1$ and $y_0(t) = t(t+1)$.

Solution. We have:

$$\begin{aligned} & \frac{\partial f}{\partial x} \Big|_{(x=x_0, y=y_0)}(x - x_0) + \frac{\partial f}{\partial y} \Big|_{(x=x_0, y=y_0)}(y - y_0) \approx 0 \\ \Leftrightarrow & (-2tx) \Big|_{(x=t+1, y=t(t+1))}(x - x_0) + (t+1) \Big|_{(x=t+1, y=t(t+1))}(y - y_0) \approx 0 \\ \Leftrightarrow & -2t(t+1)\delta x(t) + (t+1)\delta y(t) \approx 0 \\ \Leftrightarrow & -2t\delta x(t) + \delta y(t) \approx 0 \end{aligned}$$

Note that the last equation is linear, but time-variant. □

- The approach can be applied to linearize nonlinear differential equations as well. For example, let

$$f(x, \dot{x}, y, \dot{y}, \ddot{y}) = 0 \tag{2.4}$$

be a second-order nonlinear differential equation. If $op = (x_0(t), \dot{x}_0(t), y_0(t), \dot{y}_0(t), \ddot{y}_0(t))$ is a solution of (2.4) (in other words, op is an operating point), then one can linearize

the equation by expanding f around the operating point into a Taylor series as a function of variables $x, \dot{x}, y, \dot{y}, \ddot{y}$:

$$\frac{\partial f}{\partial x}|_{op}\delta x + \frac{\partial f}{\partial \dot{x}}|_{op}\delta \dot{x} + \frac{\partial f}{\partial y}|_{op}\delta y + \frac{\partial f}{\partial \dot{y}}|_{op}\delta \dot{y} + \frac{\partial f}{\partial \ddot{y}}|_{op}\delta \ddot{y} \approx 0$$

Example 4 Linearize the nonlinear differential equation

$$2tx(t) - \dot{x}(t)y^2(t) + x(t)\dot{y}^3(t) = t(t + 1)$$

around the operating point $x_0(t) = y_0(t) = t$.

Solution. First note that $(x_0(t), \dot{x}_0(t), y_0(t), \dot{y}_0(t)) = (t, 1, t, 1)$ is a solution of the above equation. Let

$$f(x, \dot{x}, y, \dot{y}) = 2tx - \dot{x}y^2 + x\dot{y}^3 - t(t + 1)$$

The linear approximation of $f(x, \dot{x}, y, \dot{y}) = 0$ around the operating point will be

$$\begin{aligned} & \frac{\partial f}{\partial x}|_{(x_0, \dot{x}_0, y_0, \dot{y}_0)=(t, 1, t, 1)}\delta x + \frac{\partial f}{\partial \dot{x}}|_{(t, 1, t, 1)}\delta \dot{x} + \frac{\partial f}{\partial y}|_{(t, 1, t, 1)}\delta y + \frac{\partial f}{\partial \dot{y}}|_{(t, 1, t, 1)}\delta \dot{y} \approx 0 \\ \Leftrightarrow & (2t + \dot{y}^3)|_{(x_0, \dot{x}_0, y_0, \dot{y}_0)=(t, 1, t, 1)}\delta x - y^2|_{(t, 1, t, 1)}\delta \dot{x} - 2\dot{x}y|_{(t, 1, t, 1)}\delta y + 3x\dot{y}^2|_{(t, 1, t, 1)}\delta \dot{y} \approx 0 \\ \Leftrightarrow & -2t\delta y + 3t\delta \dot{y} \approx -(2t + 1)\delta x + t^2\delta \dot{x} \end{aligned}$$

□

An operating point is called an *equilibrium point* if the derivatives of all system variables are equal to zero. Informally speaking, at equilibrium all system variables have reached constant values.

Example 5 Find an equilibrium point for the system described by the nonlinear differential equation

$$\ddot{\theta} + \dot{\theta} + \cos \theta = \frac{\sqrt{2}}{2} \tag{2.5}$$

and linearize the system around it.

Solution. At equilibrium we must have $\ddot{\theta}_0 = \dot{\theta}_0 = 0$, implying that $\cos \theta_0 = \frac{\sqrt{2}}{2}$. So for instance $\theta_0 = \frac{\pi}{4}$ is an equilibrium point and a solution of (2.5). Denote $eq := (\theta_0, \dot{\theta}_0, \ddot{\theta}_0) = (\frac{\pi}{4}, 0, 0)$ and let

$$f(\ddot{\theta}, \dot{\theta}, \theta) = \ddot{\theta} + \dot{\theta} + \cos \theta - \frac{\sqrt{2}}{2}$$

The linear approximation of $f(\ddot{\theta}, \dot{\theta}, \theta) = 0$ around the equilibrium point will be

$$1|_{eq}\delta\ddot{\theta} + 1|_{eq}\delta\dot{\theta} - \sin\theta|_{eq}\delta\theta = 0$$

After substituting for θ , $\dot{\theta}$, and $\ddot{\theta}$ at equilibrium, we obtain:

$$\delta\ddot{\theta} + \delta\dot{\theta} - \frac{\sqrt{2}}{2}\delta\theta = 0$$

□

Example 6 Consider a system described by the nonlinear differential equation

$$y\ddot{y} + x^2\dot{y} + \sqrt{y} = x \quad (2.6)$$

Assume that input is constant $x := x_0$. Find an equilibrium point and linearize the system around it.

Solution. Since at equilibrium point (x_0, y_0) all derivatives are zero we must have $\sqrt{y_0} = x_0$, implying that $y_0 = x_0^2$. Let:

$$f(\ddot{y}, \dot{y}, y, x) = y\ddot{y} + x^2\dot{y} + \sqrt{y} - x$$

The linear approximation of $f(\ddot{y}, \dot{y}, y, x) = 0$ around the equilibrium point will be

$$\begin{aligned} & \frac{\partial f}{\partial \ddot{y}}|_{(x_0, x_0^2)}\delta\ddot{y} + \frac{\partial f}{\partial \dot{y}}|_{(x_0, x_0^2)}\delta\dot{y} + \frac{\partial f}{\partial y}|_{(x_0, x_0^2)}\delta y + \frac{\partial f}{\partial x}|_{(x_0, x_0^2)}\delta x \approx 0 \\ \Leftrightarrow & (y)|_{(x_0, x_0^2)}\delta\ddot{y} + (x^2)|_{(x_0, x_0^2)}\delta\dot{y} + (\dot{y} + \frac{1}{2\sqrt{y}})|_{(x_0, x_0^2)}\delta y + (2x\dot{y} - 1)|_{(x_0, x_0^2)}\delta x \approx 0 \\ \Leftrightarrow & x_0^2\delta\ddot{y} + x_0^2\delta\dot{y} + \frac{1}{2x_0}\delta y - \delta x \approx 0 \end{aligned}$$

□

2.2 Block diagrams

We use block diagrams to model systems and to describe how their different subsystems are interconnected. A signal traverses a block diagram in the direction of *arrows*. Each *block* represents a subsystem. When a subsystem is LTI, its representing block is labelled by the transfer function from input to output. Finally, a *sensing device*, represented by a circle, performs mathematical operations such as addition, subtraction, and multiplication on the incoming signals.

To obtain the transfer function of the entire system from input $U(s)$ to output $Y(s)$, we introduce auxiliary variables as necessary and write down linear algebraic equations at the output of blocks and sensing devices. Then we proceed by eliminating auxiliary variables to obtain an expression relating $Y(s)$ to $U(s)$, which can be rewritten to obtain the system transfer function.

Example 7 The block diagram of an LTI system is shown in Figure 2.3.

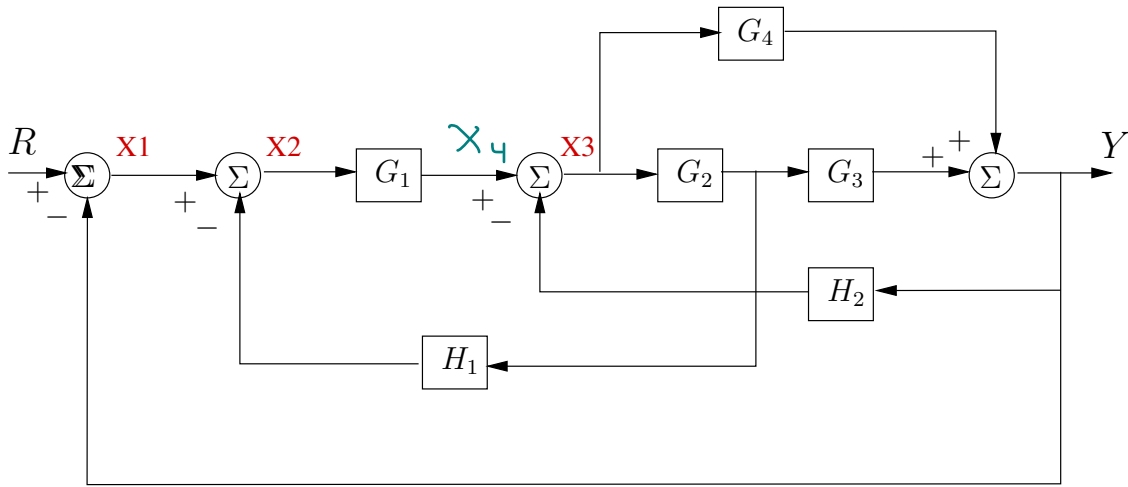

Figure 2.3: Block diagram of Example 7.

Find the transfer function $\frac{Y(s)}{R(s)}$.

Solution. We start by introducing 3 auxiliary variables X_1 , X_2 and X_3 . Therefore, we need to write 4 equations to fully describe the system.

$$X_1 = R - Y \tag{2.7}$$

$$X_2 = X_1 - G_2 H_1 X_3 \tag{2.8}$$

$$X_3 = G_1 X_2 - H_2 Y \tag{2.9}$$

$$Y = G_4 X_3 + G_2 G_3 X_3 \tag{2.10}$$

To eliminate the auxiliary variables, first solve (2.10) for X_3 to obtain

$$X_3 = \frac{Y}{G_2 G_3 + G_4} \tag{2.11}$$

Substitute X_3 from (2.11) into (2.9) to obtain

$$\begin{aligned} \frac{Y}{G_2 G_3 + G_4} &= G_1 X_2 - H_2 Y \\ \Leftrightarrow Y \left(\frac{1}{G_2 G_3 + G_4} + H_2 \right) &= G_1 X_2 \\ \Leftrightarrow Y \frac{G_2 G_3 H_2 + G_4 H_2 + 1}{G_2 G_3 + G_4} &= G_1 X_2 \end{aligned}$$

Therefore

$$X_2 = Y \frac{G_2 G_3 H_2 + G_4 H_2 + 1}{G_1 G_2 G_3 + G_1 G_4} \quad (2.12)$$

Finally, substitute X_1 from (2.7), X_2 from (2.12) and X_3 from (2.11) into (2.8) to obtain a relationship between R and Y :

$$\begin{aligned} Y \frac{G_2 G_3 H_2 + G_4 H_2 + 1}{G_1 G_2 G_3 + G_1 G_4} &= R - Y - G_2 H_1 \frac{Y}{G_2 G_3 + G_4} \\ \Leftrightarrow Y \left(\frac{G_2 G_3 H_2 + G_4 H_2 + 1}{G_1 G_2 G_3 + G_1 G_4} + \frac{G_2 H_1}{G_2 G_3 + G_4} + 1 \right) &= R \\ \Leftrightarrow Y \left(\frac{G_2 G_3 H_2 + G_4 H_2 + 1 + G_1 G_2 H_1 + G_1 G_2 G_3 + G_1 G_4}{G_1 G_2 G_3 + G_1 G_4} \right) &= R \end{aligned}$$

It follows that

$$\frac{Y}{R} = \frac{G_1 G_2 G_3 + G_1 G_4}{1 + G_1 G_2 G_3 + G_1 G_2 H_1 + G_1 G_4 + G_2 G_3 H_2 + G_4 H_2}.$$

□

Important remark. The problem of finding the transfer function of a block diagram boils down to solving a set of linear algebraic equations. In the above example, there are 4 equations (2.7), (2.8), (2.9) and (2.10) in 4 unknowns X_1 , X_2 , X_3 and Y . The system transfer function is obtained upon solving the set of equations for Y . **You can use the method of your choice to solve the set of equations.** □

2.2.1 Block diagram reduction

A block diagram can be reduced in several ways to a simpler block diagram with fewer blocks than the original, yet the same transfer function from input to output. Table BT 2.6 shows a few simple tricks for simplifying block diagrams. They all can be derived by simple manipulation of equations representing blocks.

Example 8 The block diagram of BF 2.26 is repeated in Figure 2.4.

The block diagram reduction method presented in the textbook relies on elimination of the system's 3 feedback loops. That is, it applies the 6th reduction rule of table BT 2.6 to eliminate all feedback loops. To make the block diagram ready for the first application of rule # 6, rule # 4 is applied to move the pickoff point labelled by (*) in Figure 2.4 ahead of the block with transfer function G_4 . As a result of this move, gain of the corresponding branch is divided by G_4 . The procedure is illustrated in BF 2.27.

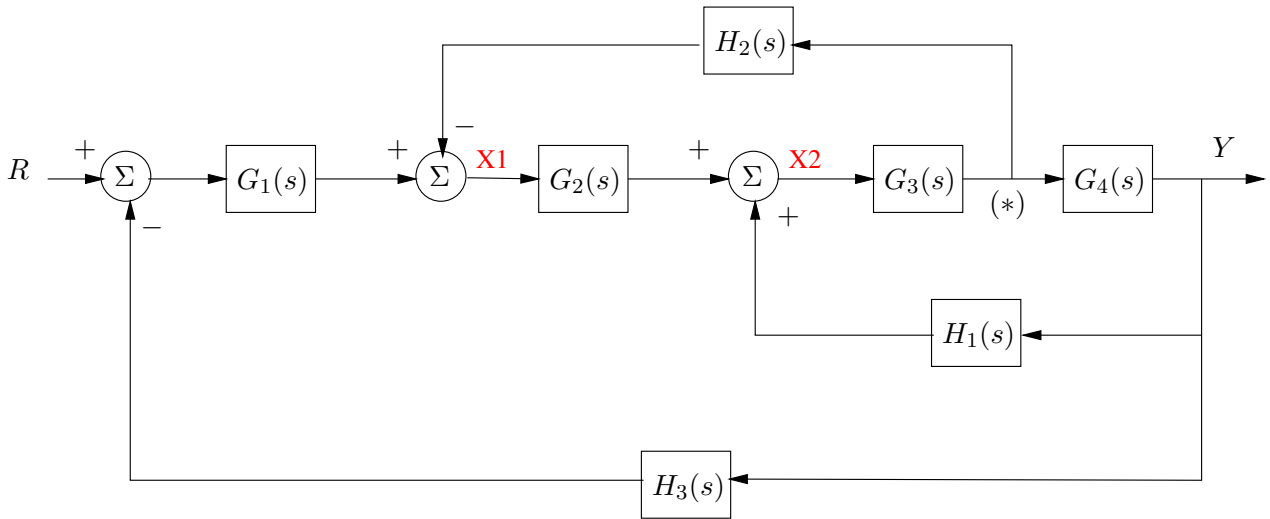

Figure 2.4: A multiple-loop feedback control system.

Alternative approach. We write all the block diagram equations from scratch. Referring to Figure 2.4, after defining 2 auxiliary variables, we must write down 3 equations.

$$X_1 = G_1(R - H_3Y) - G_3H_2X_2 \quad (2.13)$$

$$X_2 = G_2X_1 + H_1Y \quad (2.14)$$

$$Y = G_3G_4X_2 \quad (2.15)$$

From (2.15) we obtain

$$X_2 = \frac{Y}{G_3G_4} \quad (2.16)$$

Next, substitute the above value for X_2 in (2.14) to obtain X_1 in terms of Y :

$$\begin{aligned} \frac{Y}{G_3G_4} &= G_2X_1 + H_1Y \\ \Leftrightarrow \frac{Y}{G_3G_4} - H_1Y &= G_2X_1 \end{aligned}$$

It follows that

$$X_1 = Y \frac{1 - G_3G_4H_1}{G_2G_3G_4} \quad (2.17)$$

Finally substitute X_1 from (2.17) and X_2 from (2.16) into (2.13) to obtain:

$$\begin{aligned} Y \frac{1 - G_3 G_4 H_1}{G_2 G_3 G_4} &= G_1 (R - H_3 Y) - G_3 H_2 \frac{Y}{G_3 G_4} \\ \Leftrightarrow Y \left(\frac{1 - G_3 G_4 H_1}{G_2 G_3 G_4} + G_1 H_3 + \frac{G_3 H_2}{G_3 G_4} \right) &= G_1 R \\ \Leftrightarrow Y \left(\frac{1 - G_3 G_4 H_1 + G_1 G_2 G_3 G_4 H_3 + G_2 G_3 H_2}{G_2 G_3 G_4} \right) &= G_1 R \end{aligned}$$

It follows that

$$\frac{Y}{R} = \frac{G_1 G_2 G_3 G_4}{1 - G_3 G_4 H_1 + G_1 G_2 G_3 G_4 H_3 + G_2 G_3 H_2}$$

□

Which method is more effective? The choice is yours. Perhaps a combination of both techniques will result in the right answer in the shortest amount of time, i.e. apply a reduction rule wherever you see its immediate application. Then, solve the reduced diagram by writing its algebraic equations.