

THE AUSTRALIAN INSTITUTE OF  
REFRIGERATION, AIR CONDITIONING AND HEATING

**BEST  
PRACTICE**

**GUIDELINES**

# Water conservation in cooling towers



**BEST  
PRACTICE  
GUIDELINES**

# Water conservation in cooling towers

Editor: **V J Aherne** BSc(Hons)Eng, MEnvMgt, Dip BEng, Cert. Eng, M AIRAH

## Intent

This document has been prepared to assist the owners and operators of cooling towers and evaporative cooling systems in reducing the water consumption of cooling systems while retaining required performance. The intention is to identify the ways in which a cooling tower consumes water and outline a series of best practice recommendations to assist the tower operator or water treatment service provider in the reduction of overall tower water consumption.

## Acknowledgements

This guide was extensively reviewed by industry prior to publication. AIRAH wishes to acknowledge the many people who have contributed to the preparation of the document by way of review and comment including;

- **Simon Bradwell**, Ebm Papst
- **Clive Broadbent** L.AIRAH, Clive Broadbent and Associates
- **Sven Denton** M.AIRAH, AquaKlar
- **John Fletcher**, AECOM
- **Mike Hogan** M.AIRAH, Cooling Solutions

- **Nitin Joglekar** M.AIRAH, BECA
- **Bryon Price** M.AIRAH, A.G. Coombs Group
- **Stan Wesley** L.AIRAH
- **Phil Wilkinson**, AIRAH
- **Bernie Zwolack**, M.AIRAH, ECC
- **Michael Buhagiar** Affil.AIRAH, Water Control Services (Aust)
- **Greg Downing**, Hydrochem
- **Nick Duncan**, M.AIRAH, Hydrochem
- **Stephen Elsom**, Integra Water
- **Kevin Shaw**, NALCO
- **Gary Erickson**, Spirax Sarco
- **Clive Roscoe**, Ashland
- **David Buckley**, Tandex
- **Helen Millicer**, PACIA
- **John Fawcett**, City West Water
- **Rohan Barron**, City West Water

The assistance from these people is very much appreciated.

Proudly supported by:



## Disclaimer

The information or advice contained in this document is intended for use only by persons who have had adequate technical training in the field to which the guide relates. The document has been compiled as an aid only and the information or advice should be verified before it is put to use by any person. The user should also establish the applicability of the information or advice in relation to any specific circumstances. While the information or advice is believed to be correct the Australian Institute of Refrigeration Air Conditioning and Heating Inc., its officers, employees and agents, disclaim responsibility for any inaccuracies contained within the document including those due to any negligence in the preparation and publication of the said document.

© AIRAH 2009

ISBN 978-0-949436-47-4

**Design and layout:** Artifishal Studios 140 Johnston St, Fitzroy Victoria 3065 Tel: 03 9417 7420 | [www.artifishal.com.au](http://www.artifishal.com.au)

# Contents

1.1.	<b>Introduction</b>	<b>3</b>	1.5.	<b>Managing cooling tower operations</b>	<b>15</b>
1.2.	Water use and conservation	4	1.5.1.	Metering	15
1.3.	Addressing the tower water balance	5	1.5.2.	Monitoring	16
1.3.1.	Evaporation	5	1.5.3.	Optimise efficiency	16
1.3.2.	Bleed	5	1.5.4.	Maintenance	16
1.3.3.	Cycles of concentration	6	1.5.5.	Recommissioning and system tuning	16
1.3.4.	Drift	7	1.6.	<b>Optimising water management</b>	<b>17</b>
1.3.5.	Overflow	7	1.6.1.	Water treatment systems	17
1.3.6.	Pump gland leakage	8	1.6.2.	Water filters and strainers	17
1.3.7.	Splash out	8	1.6.3.	Make-up water filtration	18
1.3.8.	Windage	8	1.6.4.	Bleed water line filtration	18
1.3.9.	Leaks	8	1.7.	<b>Alternative water sources and uses</b>	<b>18</b>
1.3.10.	Other water losses	8	1.7.1.	Water sources	18
1.3.11.	Make-up water	8	1.7.2.	Water quality	19
1.3.12.	Setting the correct make-up level	9	1.7.3.	Onsite reuse of water	19
1.3.13.	Water pressure	9	1.8.	Refurbishments, upgrades and redesign	19
1.4.	<b>Auditing the cooling tower water use</b>	<b>9</b>	1.9.	<b>Further information</b>	<b>20</b>
1.4.1.	Water efficiency audits	9			
	<b>Cooling tower water Audit Checklist</b>	<b>10</b>			
1.4.2.	Water efficiency reporting	12			
	<b>Cooling tower water Audit Report</b>	<b>12</b>			
	<b>Audit Comments</b>	<b>14</b>			
1.4.3.	Calculating water efficiency	15			
1.4.4.	Water efficiency training	15			



## BEST PRACTICE GUIDELINES

# Water conservation in cooling towers

## 1.1. Introduction

An open circuit or evaporative cooling tower is a heat rejection device that rejects heat to the atmosphere by cooling a water stream to a lower temperature. The tower takes the heat from the water stream and rejects it to the air stream and cooling is partly achieved through the evaporation of a portion of the water. The transferred heat raises the air temperature and relative humidity and this air is discharged to atmosphere where it dissipates. The cooled water is collected and pumped back through the load/process to absorb more heat.

Cooling towers are effective heat rejection devices however they are responsible for the use of large volumes of, in most cases, potable water and can account for up to half of a buildings' or a site's total water usage. The cooling towers of large commercial buildings and complex industrial processes can consume huge volumes of potable water over time. With the increasing cost of water and increasing concern regarding its future scarcity, cooling tower water consumption must be well managed and reduced where possible.

The water efficiency principles contained within this Best Practice Guide apply to typical cooling towers and operators. The standardised steps will be particularly helpful to operators of HVAC&R and standalone systems; operators responsible for integrated and complex operating systems as part of a complex facility may need to include other factors, such as down stream use of bleed,

to achieve total site water efficiency and should consult their expert water treatment service provider.

### Operators should optimise cooling tower water consumption to:

- ▲ Conserve water resources, reduce waste, reduce costs and save money,
- ▲ Comply with any related law or regulation where stipulated,
- ▲ Be environmentally responsible,
- ▲ Assist with environmental ratings or green lease commitments,
- ▲ Help demonstrate corporate environmental credentials.

This document aims to identify the main ways in which a cooling tower consumes water and outlines a series of recommendations to assist the tower operator or water treatment service provider in the reduction of tower water consumption.

### Operators can reduce cooling tower water consumption by:

- Reducing the cooling load and improving tower/system control,
- Optimising the cycles of concentration and minimising bleed volume,
- Minimising drift,
- Preventing any overflows,

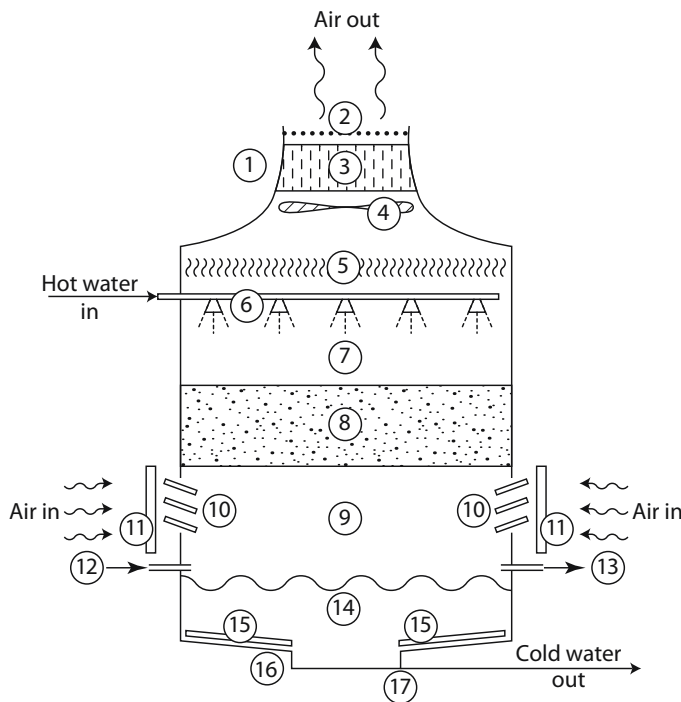

- 1: Fan stack
- 2: Discharge grille or screen
- 3: Sound attenuator
- 4: Fan
- 5: Drift eliminator
- 6: Water distribution system/nozzles
- 7: Plenum
- 8: Fill packing
- 9: Plenum
- 10: Air inlet louvres
- 11: Grilles, screens, filters
- 12: Make-up water inlet
- 13: Overflow
- 14: Cold water basin
- 15: Basin sweeper piping
- 16: Sump
- 17: Tower outlet with screen and strainer

Figure 1.1 Cooling tower components

- Preventing loss from any windage or splash out,
- Maintaining valves, sensors and all equipment to prevent leaks,
- Managing backwash and system cleaning water,
- Providing best practice management and water conservation training.

Cooling towers range in size and complexity. There are very many that are small in energy and water use (kW and kL per week) and a few that are very large in energy and water use and are generally unique (MW and ML per day). Very large towers are often managed by specialist service providers, experts in their field, who can competently apply innovative management strategies and techniques to tower water management as part of an integrated water management plan for a complex industrial plant. Additionally water consumption or water conservation may not be the focus or priority for towers associated with critical industrial processes. Alternative management strategies and audit methods, not consistent with the recommendations of this document or that are not mentioned in it but which can produce equivalent outcomes, are not necessarily prohibited.

## 1.2. Water use and conservation

Recommendations to reduce cooling tower water consumption can be listed or categorised under the following headings;

### Address tower water balance and consumption

— To optimise the water conservation of any cooling tower the entire water balance of the tower should be addressed. Water outflows (losses) include evaporation, bleed, overflows, drift, splash-out, windage and system leaks. Some water outflows are controlled (evaporation and bleed) and are essential to the correct operation of the tower and system. These controlled outflows need to be optimised. Some water outflows are uncontrolled (overflows, drift, splash out, windage, leaks and filter backwashing). Uncontrolled water outflows need to be minimised or removed. See 1.3.

**Audit the tower water balance** — The water efficiency of a system needs to be optimised and the first step is to conduct a system water audit. The key water parameters are measured, recorded and system KPIs calculated. The water efficiency is calculated in accordance with the AIRAH Cooling Tower Water Efficiency Calculator (<http://www.ctwec.com/>) and reported. See 1.4.

**Manage the tower operation** — Regular monitoring of a cooling towers' normal water usage pattern will identify any peaks or irregularities in water consumption. Water meters need to be placed on the make-up water line and, where practical and economically feasible, the bleed water line to effectively understand the tower water consumption pattern. Suitable meters such as electromagnetic flow meters, which will not block or foul from particulate matter, should be used on bleed lines. Towers need to be regularly audited and their performance and condition assessed. Cooling towers and associated systems require regular maintenance and need to be periodically fine tuned to ensure that they

continue to match operational loads and are providing optimal performance. Water and energy use should be continually reviewed to ensure that the benefits of any system improvements or refinements are achieved. A well managed system, whether it is in an industrial or HVAC&R application, will generally reject more heat, use less power, consume less water and produce less risk than a poorly managed system. See 1.5

**Optimise water management** — water treatment systems should be optimised and reviewed for their effectiveness and operation. Water filters need to be maintained and their application reviewed with respect to contaminant challenges. Filter backwash and cleaning/maintenance water needs to be quantified and managed and any makeup and bleed filtration optimised. See 1.6.

**Alternative water sources and uses** — Utilising alternative water sources can significantly reduce the potable water consumption of the tower. Bleed water and any water used for system cleaning and maintenance can be captured, reused and recycled to improve the overall water consumption of the facility. See 1.7.

**Refurbishment and upgrades** — Scheduled replacements and upgrades provide an opportunity to improve the performance and sustainability and reduce the water consumption of older cooling water systems. See 1.8.

Each of these areas and the associated water conservation opportunities is outlined and explained in greater detail in the following sections of this document.

## 1.3. Addressing the tower water balance

The water balance of a tower or cooling water system involves all of the water inputs and outputs associated with the operation of the system. Water outputs from a cooling tower include controlled losses such as evaporation, bleed, drift and pump gland leakage and uncontrolled losses including leaks, splash out, overflows and windage. All of these losses are replaced by makeup water from the system water supply.

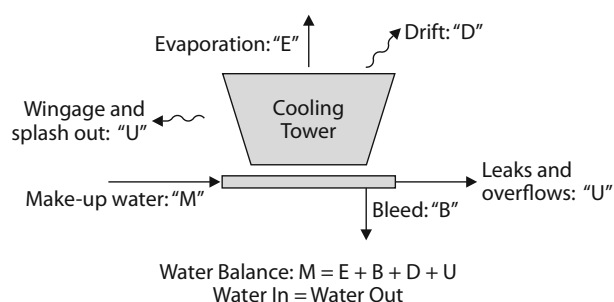

Figure 1.2 Cooling tower water balance

### 1.3.1. Evaporation

Evaporation is a necessary part of the system operation and can only be reduced by a reduction in the cooling load or by increasing the level of dry cooling being achieved by a hybrid tower. A simple assessment of the tower evaporation rate can be made by the WTSP.

Evaporation can be reduced by:

- Reducing the cooling load (refer to AIRAH DA19)
- Optimising the system operation (see 1.5.3)
- Upgrading or redesigning the system (see 1.8)

### 1.3.2. Bleed

By evaporating water a cooling tower concentrates both dissolved and undissolved (suspended) solids within the system circulating water. As water contaminants build up the concentration level of impurities or total dissolved solids (TDS) in the circulating water should be controlled by bleeding a portion of the circulating water from the system and replacing it with relatively clean make-up water. Without this control the TDS level in the circulating water will increase and if left unchecked it may lead to scaling and fouling of not only the cooling tower, but also the system heat exchangers.

Bleed water is taken from the system either continuously or intermittently. A bleed valve, automatically controlled by a conductivity sensor, is the preferred method of bleed control. Bleed volumes should be metered. Bleed control valves and bleed meters should be protected from the contaminants in the bleed water by strainers or filters. Bleed is automatically replaced by make-up water.

**Bleed volumes can be reduced by:**

- Optimising the cycles of concentration (see 1.3.3)
- Utilising appropriate water management strategies (see 1.6),
- Improving the control of the bleed system,
- Maintaining and protecting the bleed valve,
- Regularly maintaining and calibrating the conductivity sensor.

The bleed take-off point should be located on the high pressure side of the system after the heat exchanger as this water is the warmest and is the most depleted of any water treatment chemicals. Taking bleed from a low pressure area may cause practical difficulties with metering this water volume. Taking bleed from the tower cold water basin reduces system capacity as the bleed water would have already been cooled by the tower. It is more efficient to take bleed from before the tower inlet.

Bleed water tends to be the most contaminated water in the system and suspended solids within the water can block open the solenoid valve and cause significant uncontrolled water losses or prevent the solenoid valve

from opening preventing any bleed. It is good practice to protect the automatic bleed water valve with a strainer or filter installed upstream of the solenoid valve on the bleed line. A number of automated dosing and bleed packages have had the need for a solenoid protection strainer designed out of them; however the provision of a strainer is an inexpensive safeguard. If installed these protective elements also need to be inspected and maintained.

Some cooling tower bleed control systems are based on timers, water meters or are manually operated. These systems would benefit greatly from being upgraded to an automatic conductivity controlled bleed system to improve water quality control and reduce water consumption.

Regularly cleaning and calibrating the conductivity sensor will assist with accurate bleed control. Dirty sensors or sensors that are out of calibration may lead to faulty readings, excessive bleed and hence excessive water use.

Minimising bleed quantities and metering the actual bleed discharge may also assist in reducing sewerage or liquid waste disposal charges (where bleed is not reused on site).

### 1.3.3. Cycles of concentration

The term cycles of concentration (C) or concentration ratio refers to the ratio of impurities or the total dissolved solids (TDS) in the circulating water to the TDS in the make-up water.

$$C = \text{TDS circulating water} / \text{TDS make-up water}$$

It is difficult to measure TDS directly in a practical way however it is the dissolved solids in the water that make the water electrically conductive. Water with higher TDS levels is more conductive to electricity than water with lower TDS levels. Water conductivity is relatively easy to measure using current technology and this is generally the parameter used as an indicator for TDS and hence for C. Bleed volume is therefore controlled by the system conductivity sensor. Therefore C can be expressed as:

$$C = \frac{\text{conductivity of circulating water}}{\text{conductivity of make-up water}}$$

The treatment chemicals added to a system will increase the conductivity of the circulating water and this needs to be taken into consideration when controlling cycles via TDS or conductivity. The water treatment industry has traditionally utilised chlorides either as chloride ion (Cl<sup>-</sup>) or expressed as Calcium Carbonate (CaCO<sub>3</sub>). This has been conducted as a wet analysis to determine cycles of concentration to control bleed off. Some materials such as certain grades of stainless steel and protective coatings on cooling tower components may have chloride level limitations.

Cycles of concentration can have a direct effect on the corrosion/scaling potential of the circulating water and the selection of appropriate materials of construction for the cooling tower/water system combined with an

appropriate corrosion control program can allow the operator to run higher cycles of concentration than would otherwise be practicable.

The selection of an appropriate level of cycles of concentration is a complex process and operators and water treatment service providers need to adopt a holistic approach to these considerations. The upper limit to the number of cycles of concentration that can be achieved is primarily determined by the purity of the make-up water. By increasing the cycles, this reduces the bleed, thereby reducing the amount of make-up water required by the system.

However, apart from reducing the water consumption of a system by using higher cycles of concentration, there are other factors that limit the number of cycles that can be appropriately achieved as cycles of concentration can have a direct effect on:

- **Operating efficiency of the system** — Running cycles too high can increase scaling and fouling which will reduce the effectiveness and efficiency of the heat exchange process.
- **Corrosion potential of the system** — Increasing the cycles can alter the active corrosion mechanisms and reduce system component life.
- **Water treatment** — Increasing the cycles may increase the pH of the circulating water requiring additional or different water treatment controls.

Water treatment options can be used to assist in efforts to increase allowable cycles of concentration within the system. The make-up water can be pre-treated or filtered to improve its quality and hence allowing an increase in C, so reducing bleed.

Water savings achievable from the manipulation of the value of C are not endless. As can be seen from Figure 1.3 the magnitude of the water savings achievable diminishes with rising C values. Depending on the range applied (which affects evaporation rates) and generally assuming drift at 0.002% it can be seen that water savings are largest up to a C value of about 6 or 7 and water savings diminish dramatically after raising C above 10. The chemical water treatment supplier or the water treatment service provider should be consulted for the maximum allowable C value that can be achieved against the water supply quality.

The volume of water saved by increasing the cycles of concentration in a system can be estimated by the equation;

$$V = M \times ((C2 - C1) / (C1 \times (C2 - 1)))$$

Where

V = Volume of water saved

M = Initial make-up water volume

C1 = Initial Cycles of concentration number

C2 = Final cycles of concentration number

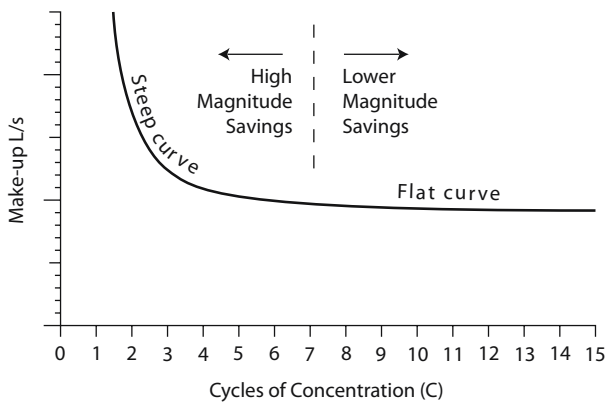

Figure 1.3 Typical relationship between water use and C in a cooling tower (5.5°C range)

Table 1.1 provides an estimate of the potential water savings that can be achieved by increasing the cycles of concentration number from C1 to C2.

### 1.3.4. Drift

Drift refers to small water droplets that leave the tower entrained in the tower discharge air. Drift is controlled largely by the towers’ design and operation and in particular by the drift eliminators design. When drift loss is expressed as a percentage, it refers to the % loss by drift in relation to the total volume of the recirculating cooling water in a system. Modern drift eliminators can achieve a drift loss of less than 0.002%. Drift is required to be below 0.002% by AS/NZS 3666.1 however controlling fan speeds and preventing ambient wind speeds from impacting the tower are ways of further reducing potential drift losses.

**Drift can be reduced by:**

- Checking that eliminators are of correct design, are installed correctly and are not damaged, fouled or blocked.

- Checking that the air flow rates are within acceptable manufacturer limits.
- Checking that the tower water pressure and flow rate is not too high.
- Providing fan speed control.
- Protecting the tower from excessive ambient winds.

Poorly modified towers, inaccurately sized towers and towers with ineffective eliminators can all result in excessive amounts of drift.

Where the actual air flow through the tower is higher than the rated air flow the volume of drift will increase and the performance of the drift eliminators will be reduced.

Check that prevailing winds and tower orientation cannot act to increase the drift characteristics of the tower. Any screening should not adversely affect the tower air intake or discharge airflows. Screens can be used to direct airflows to tower inlets.

### 1.3.5. Overflow

Overflow is an uncontrolled water loss caused by water flowing back into the cold water basin once the circulating pump has stopped. Where the volume of this water is greater than the capacity of the cold water basin the water will overflow. Overflow can be caused by poor pipework design and installation. This should be designed out of systems. Overflow can also be caused by an incorrectly set makeup level. When the operating water level is set too high in a forced draft counter flow cooling tower, overflow can result due to air pressure forcing water out of the overflow pipe. Loss can also result from a lack of protection of the overflow pipe inlet or from siphoning on system shutdown resulting from the overflow pipe being installed below the cold water basin level without an air break.

Percentage of make-up water saved												
Old cycles of concentration number C1	New cycles of concentration number C2											
		2.0	2.5	3.0	3.5	4.0	5.0	6.0	7.0	8.0	9.0	10
	1.5	33%	44%	50%	53%	56%	58%	60%	61%	62%	63%	64%
	2.0		17%	25%	30%	33%	38%	40%	42%	43%	44	45%
	2.5			10%	16%	20%	25%	28%	30%	31%	33%	34%
	3.0				7%	11%	17%	20%	22%	24%	25%	26%
	3.5					5%	11%	14%	17%	18%	20%	21%
	4.0						6%	10%	13%	14%	16%	17%
	5.0							4%	7%	9%	10%	11%
	6.0								3%	5%	6%	7%

Table 1.1 Potential water savings



**Overflow events need to be prevented and the following items should be checked:**

- Check that the ball/float valve on the make-up line can close preventing uncontrolled inflow.
- Check that the overflow pipe is not leaking.
- Check that the overflow pipe is installed at the correct level.
- Check that water is not being blown out of the overflow pipe during normal operation.
- Check that tower water distribution piping is not oversized or too long.
- Check that the operating water levels in multiple tower/cold water basins are equal.
- Check and adjust the make-up valve setting to ensure overflows do not occur on system shut down.
- Check that any makeup ball float valve is working correctly and not bouncing excessively.

### 1.3.6. Pump gland leakage

Pump gland leakage is a controlled leak designed to assist the pump glands maintain a pressure seal.

**Pump gland leakage can be reduced by:**

- Regular pump maintenance.
- Replacing glands with mechanical seals to eliminate this water loss.

### 1.3.7. Splash out

Splash out refers to water leaving the tower via the air intakes and other openings in the tower casing. It is more likely to occur when the fans have cycled off (or to a low speed) for control purposes.

**Splash out can be reduced by:**

- Installing anti splash louvres on the tower air intakes.
- Checking that anti splash louvres are installed correctly and are not damaged
- Installing a splash deck above the cold water basin.
- Ensuring the water supply pressure is not too high or outside of the manufacturers' limits.
- Ensuring that the fan speed and airflow rates are not too high or outside of the limits.

### 1.3.8. Windage

Windage refers to the effect of prevailing winds blowing water droplets out of a cooling tower, either through air inlets or outlets. Windage should not be confused with drift or splash out, both of which can occur without the presence of wind.

Windage can be reduced by protecting the tower from excessive ambient wind. Care should be taken that any

screening does not adversely affect the tower air intake or discharge airflows.

### 1.3.9. Leaks

Leaks result in water and chemical wastage and disturb the balance of water treatment systems by diluting the system with more make-up water than expected.

Leaks are minimised by periodically reviewing the cooling tower and associated system for leaks.

The best way to check for water leaks is a visual survey of the plant. Water leaks may be intermittent and physical evidence of previous leaks (stains etc.) should be investigated. Water meter and consumption levels should be checked regularly to detect changes in usage patterns. A sharp increase in water use could indicate a leak in the system. The use of water sub meters in this application is particularly useful. The presence of less obvious water leaks will be confirmed if the meter continues to tick over when all water using devices are turned off on a particular circuit.

### 1.3.10. Other water losses

Other system water losses include backwash for automatic filter cleaning and any water used for tower or component cleaning.

**Filter backwash water consumption can be reduced by:**

- Utilising compressed air for backwash/media regeneration.
- Using bleed or other recycled water for backwash purposes. Care is required to ensure that the bleed or recycled water stored for backwashing does not create microbiological contamination of the filter, media or the system.

**Cleaning water volumes can be reduced by:**

- Increasing the cleanability of the cooling tower (improve access/upgrade components).
- Using recycled or reused water for cleaning purposes.

Specific tower management activities that consume water such as cleaning protocols or periodic drain downs should be recorded and the consumption event noted. System operators need to be aware of how much water is being used by such practices. Cooling tower management and maintenance practices need to be constantly reviewed and improved to reduce this water consumption (without increasing public health, OH&S or Legionella risks).

### 1.3.11. Make-up water

To replace the water lost from or consumed by the cooling tower make-up water has to be added to the system. It is this water that is ultimately being reduced in any successful water conservation effort.

The quality of the make-up water being used in the cooling tower needs to be established. Where the quality of supplied make-up water varies over time (there are often seasonal variations) it may need to be monitored so that appropriate changes to the water treatment system and tower management can be applied. Where make-up water quality is known to be variable or subject to temporary spikes in contaminant levels alternative water sources and an automatic switch over to the alternative supply system could be considered.

Make-up water of poor or inadequate quality can be treated prior to being added to the cooling tower system. Pre-treatment can include filtration and water chemistry manipulation. Alternatively a portion of the make-up water can be pre-conditioned and then blended with the rest of the untreated make-up water prior to entering the cooling water system. Improving make-up water quality can assist in increasing the cycles of concentration number. This reduces bleed volumes which ultimately reduces the make-up water quantity required by the system.

### 1.3.12. Setting the correct make-up level

**To correctly set and commission a cooling tower make-up valve (commonly a ball/float valve) the following steps are required:**

1. Ensure that the maximum design water and air flows are being achieved by the tower.
2. Shut off the system.
3. Isolate the equaliser (balance) line for multiple towers.
4. Fill the cooling tower to 20mm below the overflow point then shut off the make-up water.
5. Turn the system back on to maximum design water and air flows and mark the drop in water level in the cold water basin.
6. Shut off the system.
7. Drain the cold water basin to the level marked.
8. Open the make-up line and adjust the make-up valve to make-up any drop in level from the marked level.
9. Fill the cooling tower to 20mm below the overflow point.
10. Open the equaliser line for multiple towers.

Use the same procedure for all towers in the system. Once set, operate all towers simultaneously and check for overflow. Stop the systems and check for overflow. If overflow continues to occur after the makeup level has been reset this indicates that there is a system design or installation problem that requires rectification.

### 1.3.13. Water pressure

Excessive pipe pressures can cause increased drift loss, incorrect operation of nozzles and possible overflowing of the hot water basin. Excessive flows reduce performance,

can damage components and are usually evidenced by excessive splash out.

Under pressure will also affect nozzle spray pattern and tower effectiveness. Air will naturally take the "dry" path (i.e. the path of least resistance) through the tower with poor water distribution further derating performance. Uniform air/water distribution over and through the fill is essential for correct tower performance.

Excessive pressure from a water supply system can be corrected by the application of pressure reducing devices at the tower inlet.

## 1.4. Auditing the cooling tower water use

The water efficiency of a system needs to be optimised and the first step is to conduct a system water audit. The audit helps to identify areas of water use and areas of potential water savings and formally identifies and reports the water efficiency of the cooling tower. The next step is to implement the changes identified and the final step is to audit the new system/operation.

### 1.4.1. Water efficiency audits

Water efficiency audits need to be carried out periodically to ensure that the system continues to perform at the required level.

**Prior to auditing a system for the first time the following assessment areas should be given particular attention:**

- The system used to control the cooling tower bleed.
- The system applied for capacity control of the cooling tower.
- The placement and operation of suitable water meters on the cooling tower makeup and bleed lines.
- The maximum cycles of concentration at which the system can operate efficiently.

The following checklist outlines the items that should be carried out in any water efficiency audit.

# COOLING TOWER WATER AUDIT CHECKLIST

NOTE: ALL AUDIT RESULTS AND COMMENTS TO BE RECORDED IN THE WATER AUDIT REPORT FORM

ITEM	Audit action	
<b>Cooling tower</b>	Check air Inlets clear of obstructions and contamination sources.	Any new plant/equipment? Any materials storage? Any building exhausts, flues etc?
	Check for airborne debris entering tower.	Any evidence leaves, litter, insects etc? Air inlet filters required?
	Check for strong wind exposure.	Screens required?
	Check drift eliminators.	Installed correctly? Clean and unobstructed?
	Check tower casing.	Free of corrosion, damage and leaks?
	Check for evidence of splash out.	Any staining on casing or support platform?
	Check for evidence of leaks.	Check tower connections and system pipework.
<b>Cooling tower components</b>	Check fill condition and installation.	Fill is clean and undamaged. No blockages. Fill is installed level?
	Check water distribution system.	Nozzles in place, undamaged, clear?
	Check water distribution pattern over fill with fan at full speed.	Water distributed evenly over fill? All sections of fill wetted?
	Check tower fan at full speed.	Record air quantity. Any unusual noise or vibration?
<b>Cooling water pump</b>	Check pump connections.	Check and adjust any packed gland seal. Replace any leaking mechanical gland seal.
<b>Cooling tower control</b>	Check control system operation.	Tower fans cycle appropriately? Variable speed drives operating?
	Check tower water and air flow rates.	Within manufacturer/design limits?
	Check variable speed drive operation.	Critical frequencies locked out?
<b>Cooling tower bleed</b>	Check make-up water meter.	Record make-up water meter reading.
	Check bleed meter.	Record bleed meter reading (if installed).
	Check bleed is automatic and conductivity controlled.	Record conductivity reading. Report if bleed control adequate.
	Check bleed solenoid valve and bleed filter.	Valve operates and closes. Clean strainer or filter.
	Check conductivity sensor.	Clean and calibrate.
	Check Cycles of Concentration number (C) for system.	Record conductivity of makeup (supply) and tower water and calculate C.

<b>Water overflow</b>	Check for any visual evidence of overflows	Record any evidence (staining etc).
	Stop pump and check for overflow.	Investigate if overflow occurs.
	Check make up valve setting.	If overflow occurred.
	Check system non return valve.	Operates correctly, not blocked.
	Check pipework design/volume.	If too large/high recommend redesign of pipework or installation of break tank.
	Check equaliser pipes and valves for multiple tower systems.	Not blocked, correct size? Basin heights equalised?
<b>Water management</b>	Check water quality parameters/KPIs.	Measure, calculate and record;
		Conductivity of tower water (uS or uohms/cm)
		Conductivity of makeup water (uS or uohms/cm)
		Leaving water temperature (°C)
		System Cycles of concentration.
		Chloride (as Cl – or as CaCO <sub>3</sub> ) (ppm)
		pH
		Total Hardness (ppm as Calcium Carbonate)
		Calcium hardness (ppm as Calcium Carbonate)
		Magnesium hardness ( ppm as Calcium Carbonate)
		P-Alkalinity
	M-Alkalinity	
	Any other specified system KPI.	
Check system filters	Clean, regenerate or replace as required.	
Check filter backwash.	Backwash meter installed? Record reading.	
Calculate tower water efficiency.	Calculate with AIRAH calculator <a href="http://www.ctwec.com/">http://www.ctwec.com/</a> or industrial water service contractor. Report result.	
<b>Cooling tower management</b>	Water conservation in water treatment and maintenance contracts?	Refer to contract.
	Regular maintenance in place?	AS/NZS 3666.2, AIRAH DA19, AS/NZS 3666.3
	Water audits carried out.	Record date of last.
	Energy audits carried out?	Record date of last.
	System optimised?	Is this system optimised? Record.
	Site log book maintained? Documentation adequate?	Record date of last entry. Operating and maintenance manuals? Licences?

### 1.4.2. Water efficiency reporting

The results of a water efficiency audit should be reported in the following standard format. For large and more complex industrial systems, other observations may be included.

## COOLING TOWER WATER AUDIT REPORT

Site details: \_\_\_\_\_

Cooling tower location and ID N°: \_\_\_\_\_

Audit date: \_\_\_\_\_

Audit completed by: \_\_\_\_\_

Report issued to: \_\_\_\_\_

Cooling tower/system details: \_\_\_\_\_

**Tower total water use —** Previous meter reading & date: \_\_\_\_\_

(Make-up water meter) Current meter reading: \_\_\_\_\_

Water used (kL): \_\_\_\_\_

Water used per day (kL/day): \_\_\_\_\_

**Tower bleed volume —** Previous meter reading & date: \_\_\_\_\_

(Bleed water meter if appl) Current meter reading: \_\_\_\_\_

Total bleed (kL): \_\_\_\_\_

Bleed per day (kL/day): \_\_\_\_\_

**Water quality parameters:**

Conductivity of tower water (uS or uohms/cm): \_\_\_\_\_

Conductivity of make-up water (uS or uohms/cm): \_\_\_\_\_

System Cycles of concentration (C): \_\_\_\_\_

Leaving water temperature (°C): \_\_\_\_\_

Chloride (as Cl – or as CaCO<sub>3</sub>) (ppm): \_\_\_\_\_

pH: \_\_\_\_\_

Total Hardness (ppm as Calcium Carbonate): \_\_\_\_\_

Calcium hardness (ppm as Calcium Carbonate): \_\_\_\_\_

Magnesium hardness (ppm as Calcium Carbonate): \_\_\_\_\_

M-Alkalinity: \_\_\_\_\_

Other specified system KPI: \_\_\_\_\_

Tower water efficiency rating: ( <http://www.ctwec.com/> ): \_\_\_\_\_Tower air quantity (m<sup>3</sup>/s): \_\_\_\_\_

Filter backwash meter reading: Previous: \_\_\_\_\_

Current: \_\_\_\_\_

Total (kL): \_\_\_\_\_

Date of previous water audit: \_\_\_\_\_

Is tower optimised (Y/N): \_\_\_\_\_

Record all comments from the water audit here;

## AUDIT COMMENTS

ITEM (Refer audit checklist)	COMMENT (Record all comments from the water audit)
Cooling tower	
Components	
Pump	
Controls	
Bleed	
overflow	
Water management	
Tower management	

Specific audit recommendations: \_\_\_\_\_

Any other comments: \_\_\_\_\_

### 1.4.3. Calculating water efficiency

Cooling tower water efficiency is calculated for any water audit. Calculations should be in accordance with the AIRAH online calculator Tool <http://www.ctwec.com/>, or in the case of large complex industrial systems this may be done via specialist provider computer software.

The AIRAH calculator is primarily based on TDS/ conductivities of recirculating cooling water and make-up water, in consideration of the set point selected for bleed. It therefore gives an overall water efficiency figure and is designed to be applied to well managed systems. The calculator does not provide for specific losses due to inefficient drift eliminators or fans. These losses are considered minor in relation to calculated overall water efficiency and are addressed in the cooling tower audit.

### 1.4.4. Water efficiency training

AIRAH is a nationally recognised registered training provider specialising in training for the HVAC&R industries. AIRAH provide nationally recognised distance education training courses on water conservation in cooling towers. AIRAH also provides one day face to face courses in water conservation and energy efficiency. The following AIRAH courses are available;

#### Distance education courses:

- Water conservation in cooling towers,
- Water treatment service providers – technician level
- Water treatment service providers – supervisor level

#### Face to face courses:

- Maintain your cool (cooling tower management)
- Carbon detectives (energy auditing and management)

AIRAH also maintains a register of accredited water treatment service providers who have been proven to meet all of the requirements of the Code of practice for water treatment service providers (Cooling Tower Systems) Victoria.

In the case of specialist water treatment service providers for large complex and unique industrial systems, they engage tertiary qualified experts and deliver in-house professional development training over years to their staff.

## 1.5. Managing cooling tower operations

### 1.5.1. Metering

In order to effectively monitor and manage the operation and performance of a cooling tower the inputs to the system and the outputs from the system need to be known and quantified. The best way to capture this information is by the installation of meters.

Owners and operators should ensure the provision of ample gauges, meters, and other instruments, of correct range and accuracy, to allow the proper testing and performance monitoring of all items of equipment in the cooling water system. Owners and operators should know how meters and data loggers can be used to monitor water consumption and operating performance.

Monitoring provides system performance data which can be compared against benchmark data. Monitoring on a more detailed level can provide valuable information on patterns of consumption and plant loading.

#### The following items should be measured and monitored for a cooling tower system:

- Make-up water flow rates and quantities.
- Bleed water flow rate and quantities.
- Fan power and energy consumption.
- Pump power and energy consumption.

#### Meters should be provided on the following cooling tower inputs:

- Fan power.
- Pump power.
- Make-up water.
- Entering water temperature (EWT).

#### Meters should also be provided on the following cooling tower outputs:

- Bleed water.
- Leaving water temperature (LWT).
- Tower water conductivity (indicates TDS).

A significant factor determining the water efficiency in a cooling water system is the cycles of concentration at which the system is operated. Raising cycles of concentration can significantly reduce bleed and hence water use. While cycles of concentration can be calculated (estimated) the direct reading of make-up and bleed water meters will provide a far more accurate assessment as it is not based on estimates (for drift, leaks, splash out, windage, overflows or leaks).

Bleed water tends to be the most contaminated water in the system and suspended solids within the water can cause operational difficulties for some meters. It is good practice to protect the meter with a strainer or filter installed upstream of the solenoid valve on the bleed line.

A conductivity meter or probe is used to control bleed in response to a predetermined setting. The setting of the conductivity meter will depend on the cycles of concentration being applied to the system.

The bleed take off point should be metered, if practical and economically feasible. Bleed off should be taken from the high pressure side of the system after the heat exchanger but before any chemical addition and before



entry to the cooling tower. Some systems take bleed from the low pressure side of the system and in this case metering is difficult. As measuring bleed is essential to water conservation and management efforts operators should consider relocating the bleed take off point to an appropriate pressure pipe or capturing and measuring the low pressure bleed in some other way. In addition backwash water and any system cleaning water should be metered or measured so that these water outputs can be quantified and managed.

### 1.5.2. Monitoring

In order for a meter to be useful in system management it should be monitored. The data should be logged at regular intervals and periodically assessed by a competent person. Operators and maintainers should be fully cognisant on how to use meters and monitors, log and record system data and assess the performance of the cooling tower system.

Conductivity and flow meters should be read regularly to quickly identify operational problems. A log of make-up, bleed, conductivity, energy consumption and the like should be maintained and trends monitored to identify deteriorations in performance.

Ideally meters, sensors and controls should interface with any Building Management System (where applicable) to facilitate continuous monitoring and control. Automatic data logging systems can be retrofitted to system meters and sensors to provide integration with the building BMS.

### 1.5.3. Optimise efficiency

Cooling water systems operation needs to be optimised. Improving system efficiency is equivalent to reducing water consumption. The cooling tower is a single component in a larger cooling water system which itself forms part of an air conditioning, refrigeration or process system. When considering operating efficiency, energy costs and water consumption operators need to assess the whole system and not simply the cooling tower. The cooling tower design condition is generally specified for the highest (or near highest) outdoor air wet bulb temperature of the year. The rest of the time the tower has the potential to either produce cooler water or to be controlled to minimise water and energy use.

Due to process or operating considerations cooling towers are often controlled on the basis of the tower leaving water temperature. Systems can be controlled to maintain the coldest possible leaving water temperature, a particular leaving water temperature or the highest allowable leaving water temperature. There are also several options as to how the temperature can be controlled including airflow control, water flow control, a combination of the two or by the use of modular components or multiple towers. Once the optimum cold water temperature is established for the cooling water system further system manipulation should

be delayed until that optimum cold water temperature is achieved.

The major energy users in a mechanical draft cooling tower are the fans and the pumps. Varying the airflow through the tower using variable speed fans offers the best method for system capacity control. Varying fan speed can significantly reduce tower energy consumption. Utilising variable speed drives on cooling tower fans offers additional operational benefits including noise reduction, less maintenance, reduced drift loss, smoother system operation and an extended service life. Variable speed drives can also be applied to pumps.

It should be remembered that each cooling tower arrangement and design will have an optimum water/air ratio. Varying air or water flow through the tower will result in variations in the water/air ratio which may change the towers' heat transfer characteristic. Operators should ensure that system control strategies do not affect the tower water/air ratio to such an extent that an overall loss of efficiency results. Comprehensive information on system optimisation is provided in AIRAH application manual DA17 Cooling Towers.

### 1.5.4. Maintenance

Routine or scheduled maintenance minimises operational risks and provides assurance that system performance is optimised. Well maintained optimised systems use less water and energy and provide better control. Maintenance of systems, particularly HVAC&R systems, should be in accordance with the recommendations of AIRAH application manual DA19 HVAC&R maintenance.

### 1.5.5. Recommissioning and system tuning

Cooling water systems should be periodically recommissioned to provide assurance that they are operating as intended. In particular system set points and control settings may need to be reset following any unauthorised changes. Depending on the precise requirements of the building operators or process the initial commissioning and system settings may need to be readdressed if the final operational requirements differ significantly from the designed requirements.

Systems that are characterised by poor performance should be totally recommissioned. Plant sizes should be checked and plant performance should be tested. System control protocols and control equipment deserve particular attention.

Even systems that are performing well should be periodically tuned including a review of system loads and control settings. Audits of cooling tower and cooling water system operation are a useful management tool and may be mandatory under state legislation in some jurisdictions.

## 1.6. Optimising water management

### 1.6.1. Water treatment systems

Assessment of the water treatment system is generally achieved by collecting samples of the system water for analysis and by the use of a corrosion monitoring and control program.

Water treatment, filtration systems, and any treatment of make-up water should all be optimised to improve system performance. The following points should be considered when attempting to optimise water treatment systems:

- Ensure that the water treatment service provider complies with this code of practice or conducts an assessment of cooling tower water use, taking account of any unique operating parameters of the system, or as part of a total facility water efficiency plan.
- Ensure that the water treatment service provider is accredited or has comprehensive training and ongoing competency testing for its field staff.
- Ensure that the water treatment service provider is licensed where applicable.
- Ensure that the water treatment provider is aware that system water efficiency is a priority.
- Reward water conservation initiatives.
- Target parameters or KPIs should be established and maintained that will control fouling, scale, corrosion and microbial populations to acceptable levels.
- Ensure that water treatment providers can model the optimum cycles of concentration.
- Cycles of concentration should be controlled through bleed off via automated conductivity (TDS) control.
- Bleed control should incorporate a lock out capability to prevent bleed during and following biocide addition.
- Monitor discharge water quality as a check step.
- Ensure that all wetted sections of the system receive regular exposure at least daily to treatment chemicals through automated control and programming.
- Regular microbiological sampling, analysis and reporting.
- Performance parameters for the water treatment provider should be set, e.g. system water use, chemical use, water quality test results.
- Ensure that a fault reporting/rectification protocol is established.

Water treatment effectiveness with respect to corrosion control can be monitored by the use of corrosion coupons or Linear Polarisation (LPR) probes.

Water treatment effectiveness with respect to mineral deposition control can be monitored by the use of make-

up and cooling water chemical analysis to perform and determine mass transport through cooling systems. Heat exchange performance monitoring and specialised on-line heat transfer modelling can also be undertaken where appropriate. Water treatment providers can advise how this is performed.

The installation of controls or system programming should be considered to periodically cycle cooling towers and cooling water system components to ensure that all sections of the system are regularly exposed to water treatment.

### 1.6.2. Water filters and strainers

Keeping the cooling water clean can help maintain good heat transfer efficiency, reduce water consumption, reduce maintenance and enhance the effectiveness of the water treatment program. Systems are prone to fouling from airborne or water borne contaminants or from contaminants associated with a process. Air contains dust, dirt, organic matter, insects, microbiological organisms and gasses. Make-up water can contain a variety of dissolved salts, suspended solids and microbiological organisms. Systems can also produce suspended solids from within due to corrosion, scale and microbiological growths.

Filtration may be employed to remove undissolved contaminant build-up from the water and improve the circulating water quality. Filters, strainers and separators all offer an effective way of removing material from the water stream. Filtration and other water cleaning systems can be either in line or side stream and basin cleaning systems can also be applied.

**The decision to use filters and the selection of the type and configuration of the filtration system will depend on:**

- The quality of make-up water being added to the system.
- The type of contaminants getting into the system.
- The type of contaminants being generated within the system.
- Contaminants already in the system.
- The operational duty of the system.
- The type of water treatment being applied.
- The cycles of concentration at which the system is being operated.

Selection of appropriate filtration systems should be made in conjunction with a specialist supplier or manufacturer and should be done in consultation with the water treatment service provider. Common systems include full stream, side stream and basin cleaning configurations utilising separators, strainers, and sand or cartridge filter systems.

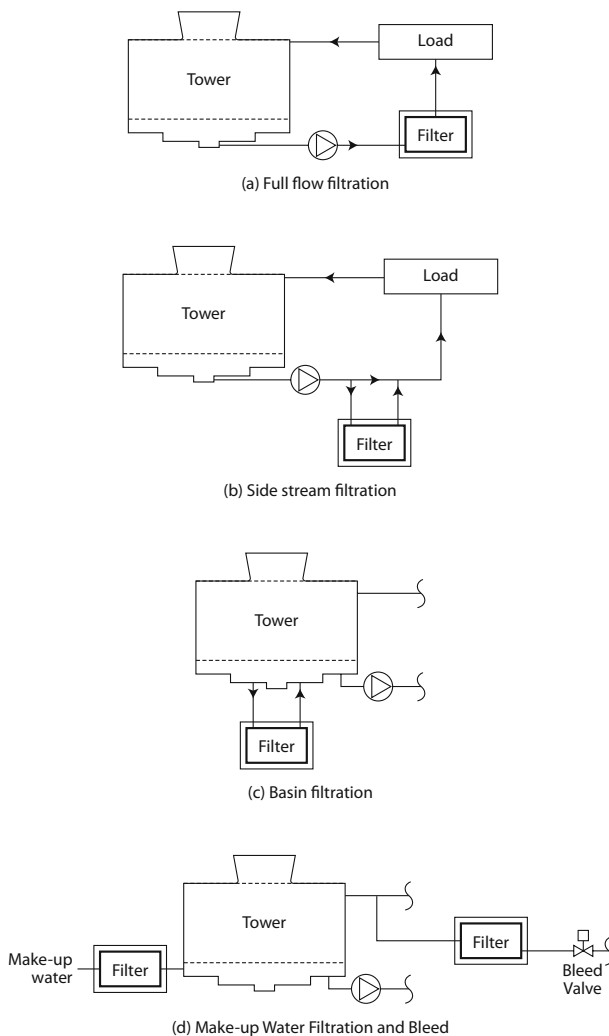

Figure 1.4 System filter location options

Some filtration systems require frequent backwashing and designers should consider options for both the reuse of this backwash water and the use of alternative (to potable) water for the purposes of backwashing. Cooling system water should only be used for backwash if the backwash quantity is less than (and integrated with) the system bleed. If the volume of backwash is too high in proportion to the bleed it represents a significant waste of water treatment chemicals and an unnecessary disturbance to system water chemistry control. Bleed water can be captured, treated and stored for use as filter backwash water. The volumes of water used by some backwashing systems can be high. Current generation high efficiency automatic self cleaning filters use considerably less water for backwash than conventional media filters. Some systems use compressed air to backwash or regenerate the filter media.

Systems that do not require backwash, including bag or cartridge filter systems generally impose a higher resistance on the pumping system as the filter removes more contamination from the water. These systems tend to have higher operating energy and consumables costs but reduced water consumption.

### 1.6.3. Make-up water filtration

Where make-up water is found to have high suspended solids content this water can be filtered prior to its introduction to the cooling water system. This can improve tower water quality by removing suspended solids so that there are less foulants reaching heat exchangers and fewer nutrients available for microorganisms. Improving make-up water quality can assist in increasing the cycles of concentration number, ultimately reducing the water consumption of the system.

### 1.6.4. Bleed water line filtration

It is good design practice to protect the automatic bleed water valve with a strainer or filter installed upstream of the solenoid valve on the bleed line. Bleed water tends to be the most contaminated water in the system and suspended solids within the water can block open the bleed valve causing significant uncontrolled water losses or prevent the solenoid valve from opening preventing any bleed. A number of automated dosing and bleed packages have had the need for a solenoid protection strainer designed out of them, however the provision of a strainer is an inexpensive safeguard. Any strainer will also protect the bleed meter.

## 1.7. Alternative water sources and uses

### 1.7.1. Water sources

Potable water has traditionally been the most common water source used in cooling water systems. Water is supplied to the site from the local water authority reticulation system and is used directly in the system. This water is fit to drink and water quality is generally high and causes few operational problems. However water usage rates for cooling towers can be high and water authorities are now encouraging system owners, designers and operators to investigate alternative sources for cooling system water. There is a growing number of industrial complexes across Australia, that use large volumes of water, now treating and reusing water in cooling towers and manufacturing processes.

**There are several options available to the operator depending on the application and location of the system. Alternative water sources for cooling towers include:**

- Rainwater and stormwater,
- Condensate from air conditioning or refrigeration systems,
- River, lake or seawater,
- Bore water or groundwater,
- Recycled or reused water.

The essential aspects of any water source selected are the water quality, the availability and its cost.

Any water reuse, rainwater, stormwater, surface water or bore water applications need to be discussed with the government authorities with jurisdiction (health, water and environmental) so that the appropriate licences and approvals are obtained to ensure that there are no public health, OH&S or environmental risks. Operators should ensure that the appropriate licences and the like have been obtained for their particular application and circumstances.

Computer software can be used to model the operational impact of using alternate water sources and mixtures as make-up water based on the chemical analysis of the proposed water sources. This process is valuable in determining the feasibility of alternative make-up water sources for the cooling tower system.

In many cases alternative water sources are backed up by traditional sources to provide for continuity of operation. Multiple sources provide some operational security and can improve system reliability and availability factors.

Pipes and tanks containing alternative non-potable water sources should be clearly labelled and identified to avoid potential cross connections with potable water or unintentional use as potable water. Back-flow prevention devices should also be fitted to prevent any contamination of potable water with non-potable water.

### 1.7.2. Water quality

An important aspect to consider when assessing the viability of alternative water sources for cooling water systems is the consistency of the water quality and the potential for variations or departures from the expected quality. The quality of the water available for use may have an impact on the cooling tower materials or operation. Cooling tower manufacturers will have a standard specification defining the water quality application limits for their equipment. This will depend on the tower materials and design and will vary between different manufacturers and tower types.

The quality of recycled or reclaimed water may vary depending on variations in the alternative water source. Cooling water systems are very susceptible to reductions in water quality or contamination and even a short-term reduction or variation can cause significant and on-going problems in the system. For example a short-term increase of oil or hydrocarbons in the make-up water may provide an ongoing supply of nutrients within the system. Some contaminants may be very difficult and expensive to remove from the pipework system.

Any alternative water source needs to be discussed with the water treatment service provider as different make-up water chemistries may have implications for the treatment program being utilised.

### 1.7.3. Onsite reuse of water

#### Reuse of bleed water

Even when cycles of concentrations have been maximised and bleed minimised the volumes of bleed water can be quite high and consideration should be given to the re-use of this water elsewhere. Bleed has been successfully used in toilet flushing, landscape irrigation, maintenance cleaning and filter backwashing applications. Bleed is stored and then reused when required. Bleed water may have high salt concentrations and may contain water treatment chemicals so care should be taken that any reuse application is suitable.

Tower bleed has been successfully used for filter backwash and in this instance a bleed holding tank is required to store water for backwashing purposes. Tower bleed water may need to be treated (filtered/disinfected) prior to use for backwashing to ensure contamination of the filter media does not occur.

#### Reuse of cleaning water

Consideration should be given to recycling and reusing the water used during tower and component cleaning procedures via a storage tank. Water captured following the cleaning of a cooling tower may contain high levels of dirt, nutrients and possibly microorganisms and may require some treatment prior to reuse.

## 1.8. Refurbishments, upgrades and redesign

Scheduled replacements and upgrades provide an opportunity to improve the performance and sustainability of older cooling water systems. Any improvement in operating performance will reduce system water consumption.

Existing systems and components may have been in place for some time and it may be possible to either upgrade tower performance with simple repairs and component upgrades or to replace the tower with the latest technology.

Continual research and development has led to improvements in corrosion resistance, component effectiveness and performance. Replacement can provide considerable benefits to the overall system. When replacing existing equipment or components, current and future requirements should be evaluated. Actual capacity requirements for plant can be measured rather than calculated providing good opportunities for right sizing of plant.

Energy efficient alternatives can be adopted and improved control or operating regimes applied. Similarly water efficient alternatives or design strategies can be adopted to improve overall system sustainability outcomes.

The cold water basin and the structural framework of the tower are generally very difficult to replace and the key to extending tower service life is maintaining the structure and basin in a useable condition. However most other tower components are often easily replaced or upgraded.

**Common upgrades include;**

- Access platforms – Added to facilitate maintenance and improve safety.
- Air intakes – Modern air intake louvres can exclude direct sunlight, reduce splash out and windage to zero while still showing less air resistance to the cooling tower fan.
- Air filters – Can be fitted onto or integrated with air intake louvres.
- Fill – New fill designs can promote better water coverage and air/water contact, fill designs and materials more suitable for contaminated water are also available.
- Drift eliminators – Modern cellular eliminators can significantly reduce drift rates and can operate at lower resistances than blade or waveform types.
- Low pressure nozzles – systems have been developed which reduce nozzle clogging characteristics.
- Fans – Modern fans operate more efficiently and are manufactured from more corrosion resistant materials.
- Fan blades – Replacement of cast metal fan blades with hollow fan blades can sometimes optimise aerodynamic blade profiles and significantly improve fan/tower performance.
- Fan controls – New control programs can be applied to optimise tower operation within the entire cooling system. These optimisation algorithms can be retrofitted onto existing systems including the fitting of required sensors.
- Fan and pump drives – Variable speed drives are now available in a wider range and at less cost than may have previously been the case.
- Fan stacks – Have benefited from new advances in design and materials.
- Water treatment – Systems can be automated and optimised.
- Water filters – Water filtration systems can be added or upgraded. Specific areas of the tower can be targeted with basin cleaning or side stream systems. Full flow filtration systems are more difficult to retrofit due to higher head requirements. Side stream systems often include their own pump which reduces this problem.
- Water distribution system – New spray nozzles can provide finer droplets at a wider coverage for less water resistance.
- Wind screens and baffles can be applied to minimise tower derating due to ambient wind effects and to minimise or reduce uncontrolled water losses due to windage.

Field applied polyurethane or other coating systems can often be applied to basins to extend their service life or improve their leak performance. Surface preparation and application techniques are critical to the success of these systems and manufacturers' recommendations should be followed.

Component upgrades should be carried out in accordance with the advice and recommendations of the original equipment manufacturer. Commissioning procedures should ensure that any new plant or operating protocols do not adversely affect the performance of existing systems. Recommissioning of existing systems may be required to ensure proper integration of the upgraded plant. It should be noted that cooling towers that undergo retrofit of components or upgrade for performance are required to fully comply with all of the requirements of AS/NZS 3666.1.

It should be remembered that cooling towers are systems within themselves. Any modification to air inlets, louvres, fill, water distribution, drift eliminators or stacks will change the internal pressure drop of the tower which will change the fan operating characteristic and the air flow. This will change the air/water interaction, tower effectiveness, tower performance and tower characteristics. All components within the tower are interlinked and operators, system maintainers and water treatment service providers should be fully cognisant of the total effect of any changes. Making changes without considering the total system consequences can lead to performance reductions (rather than improvements) or other undesirable outcomes.

Cooling water systems can be redesigned to use less water by the application of alternative design strategies such as utilising dry cooling towers, indirect cooling towers, hybrid cooling towers, evaporative condensers or the use of alternative cooling systems. While many of these systems can reduce water consumption there may be an energy penalty due to higher operating energy costs.

## 1.9. Further information

Further information on cooling towers and cooling water system design is provided in the following documents;

**AIRAH**

- DA 17 Cooling Towers
- DA 18 Water treatment
- DA 19 HVAC&R maintenance

**DHS (Victoria)**

Code of practice for water treatment service providers.

**Standard Australia**

- AS/NZS 3666 Air-handling and water systems of buildings (Parts 1, 2 & 3)
- SAA HB32 Control of microbial growth in air-handling and water systems of buildings.

