



نیمسال دوم تحصیلی ۱۳۹۳-۱۳۹۴

تکالیف مخصوص ایام نوروز	تدریس‌یار: سید حسین تکمیلی	نام استاد: دکتر محسن جنتی
تاریخ تحویل: ۱۳۹۴/۱/۲۳	نام درس: ماشین های الکتریکی ۱	رشته: مهندسی برق

- تحویل تکالیف به صورت انفرادی می‌باشد. چنانچه تحت هر شرایطی تکالیفی با هم مشابه باشند، نمره همه افراد مذکور صفر لحاظ خواهد شد.
- هیچ تکلیفی بعد از موعد اعلام گردیده، تحویل گرفته نخواهد شد.
- بارمبندی نمرات غیر قابل تغییر می‌باشد. بدیهی است در صورت عدم تحویل تکالیف، نمره مربوطه صفر منظور گردیده و به هیچ وجه قابل جبران نخواهد بود.

1- A ferromagnetic core is shown in Figure 1. The depth of the core is 5 cm. The other dimensions of the core are as shown in the figure. Find the value of the current that will produce a flux of 0.005 Wb. With this current, what is the flux density at the top of the core? What is the flux density at the right side of the core? Assume that the relative permeability of the core is 1000.

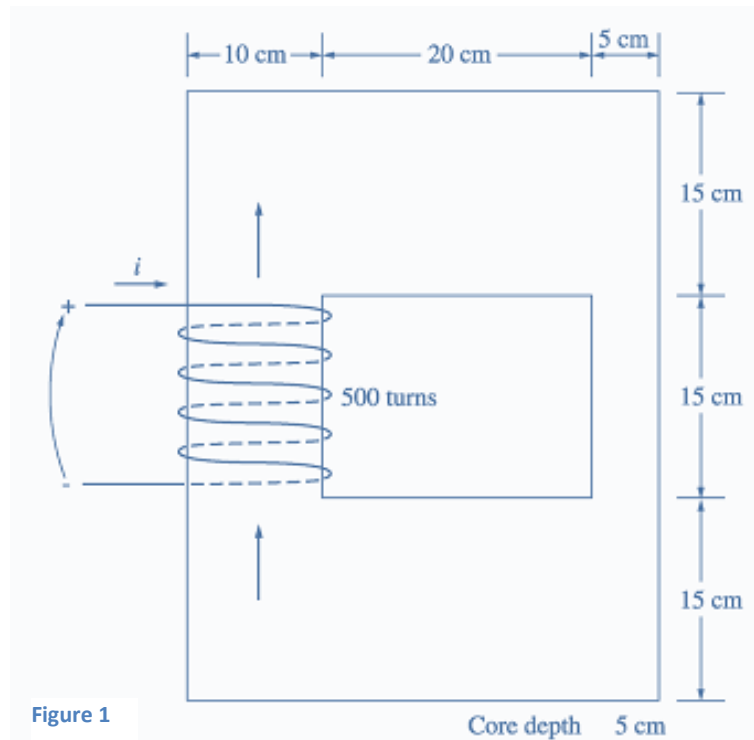

Figure 1

Core depth 5 cm

2-A ferromagnetic core with a relative permeability of 1500 is shown in Figure 2. The dimensions are as shown in the diagram, and the depth of the core is 7 cm. The air gaps on the left and right sides of the core are 0.070 and 0.020 cm, respectively. Because of fringing effects, the effective area of the air gaps is 5 percent larger than their physical size. If there are 400 turns

in the coil wrapped around the center leg of the core and if the current in the coil is 1.0 A, what is the flux in each of the left, center, and right legs of the core? What is the flux density in each air gap?

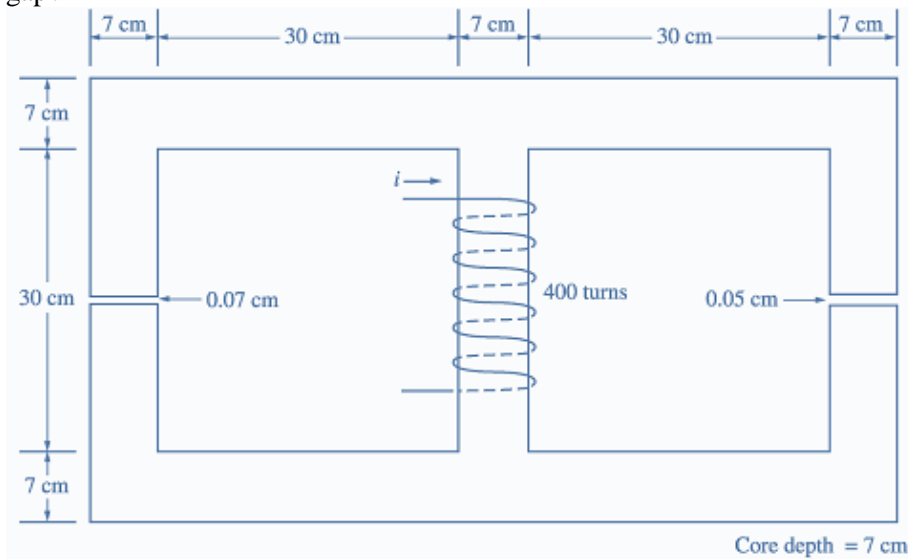

Figure 2

3-A core with three legs is shown in Figure 3. Its depth is 5 cm, and there are 200 turns on the leftmost leg. The relative permeability of the core can be assumed to be 1500 and constant. What flux exists in each of the three legs of the core? What is the flux density in each of the legs? Assume a 4% increase in the effective area of the air gap due to fringing effects.

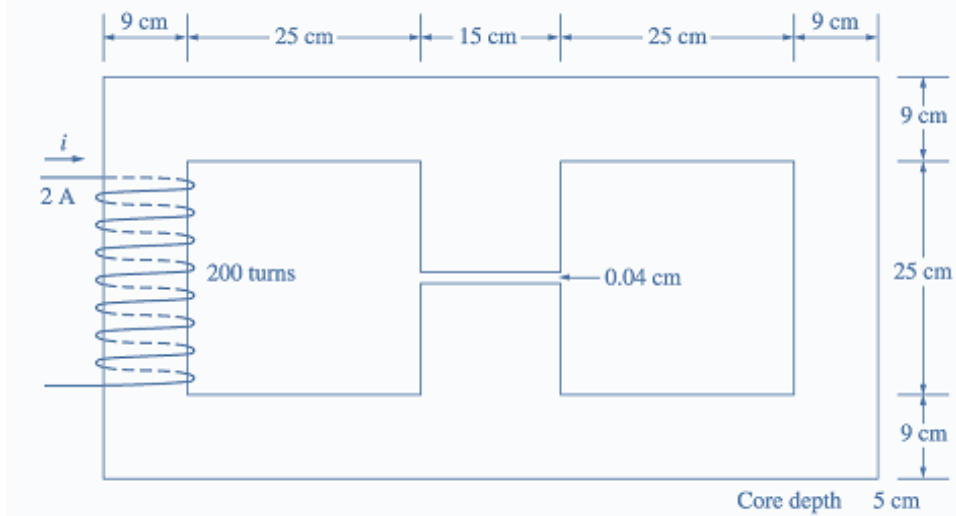

Figure 3

4-A core with three legs is shown in Figure 4. Its depth is 8 cm, and there are 400 turns on the center leg. The remaining dimensions are shown in the figure. The core is composed of a steel having the magnetization curve shown in Figure 5. Answer the following questions about this core:

- What current is required to produce a flux density of 0.5 T in the central leg of the core?
- What current is required to produce a flux density of 1.0 T in the central leg of the core? Is it twice the current in part (a)?
- What are the reluctances of the central and right legs of the core under the conditions in part(a)?
- What are the reluctances of the central and right legs of the core under the conditions in part(b)?
- What conclusion can you make about reluctances in real magnetic cores?

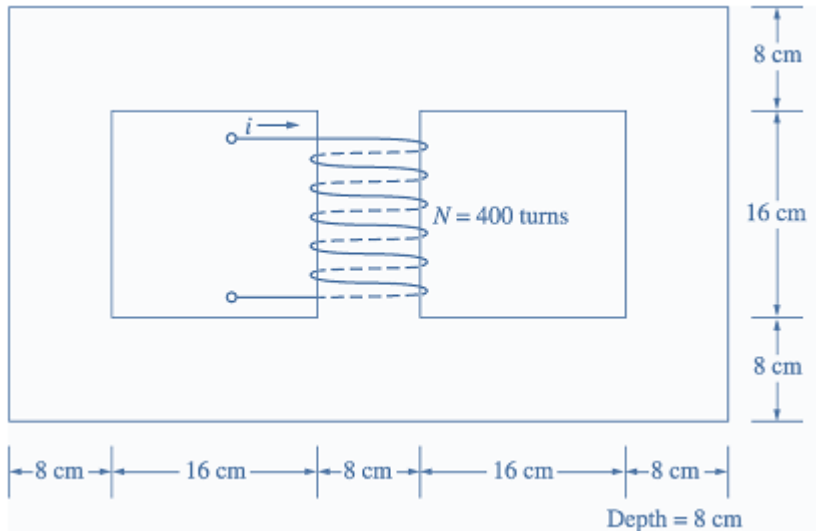

Figure 4

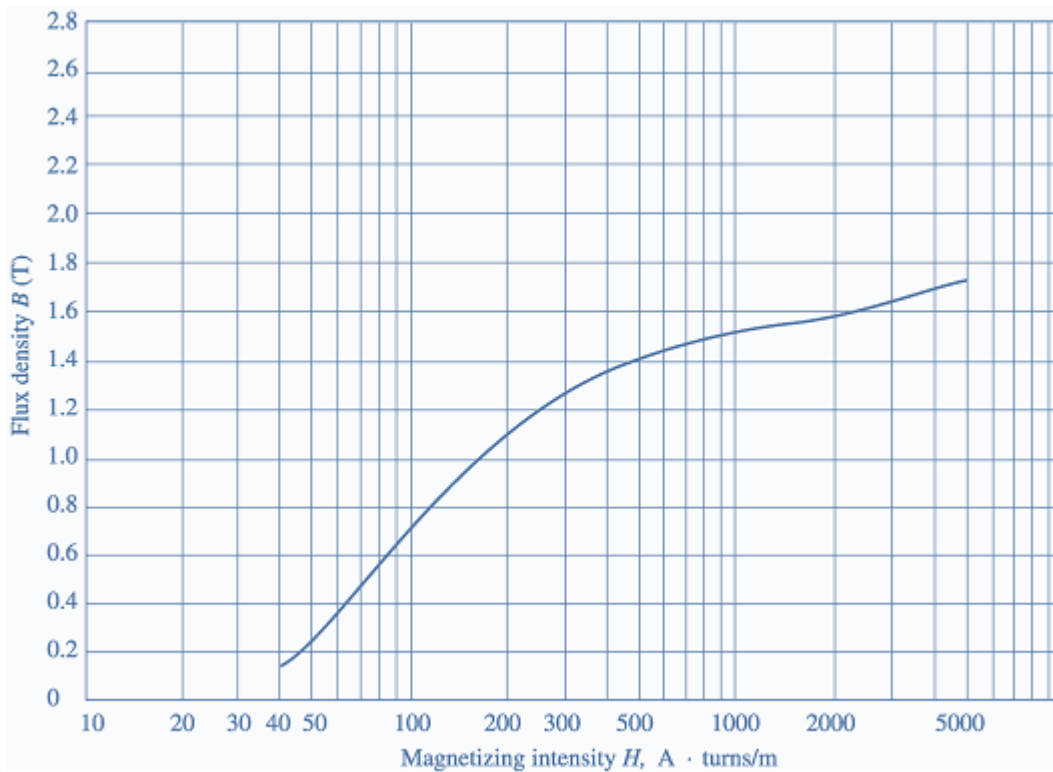

Figure 5

5-The core shown in Figure 6 has the flux  $\phi$  shown in Figure 7. Sketch the voltage present at the terminals of the coil.

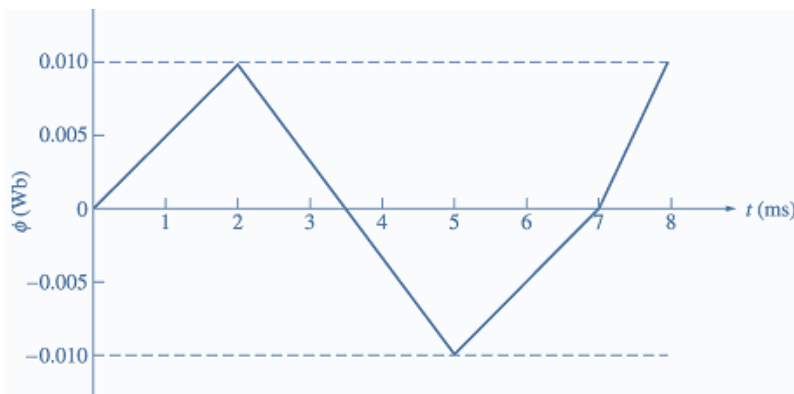

Figure 7

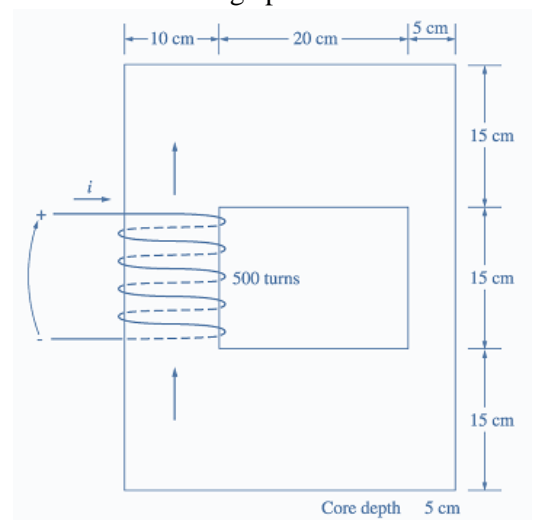

Figure 6

6-The magnetic circuit of Fig. 8 provides flux in the two air gaps. The coils ( $N_1 = 700$ ,  $N_2 = 200$ ) are connected in series and carry a current of 0.5 ampere. Neglect leakage flux, reluctance of the iron (i.e., infinite permeability), and fringing at the air gaps. Determine the flux and flux density in the air gaps.

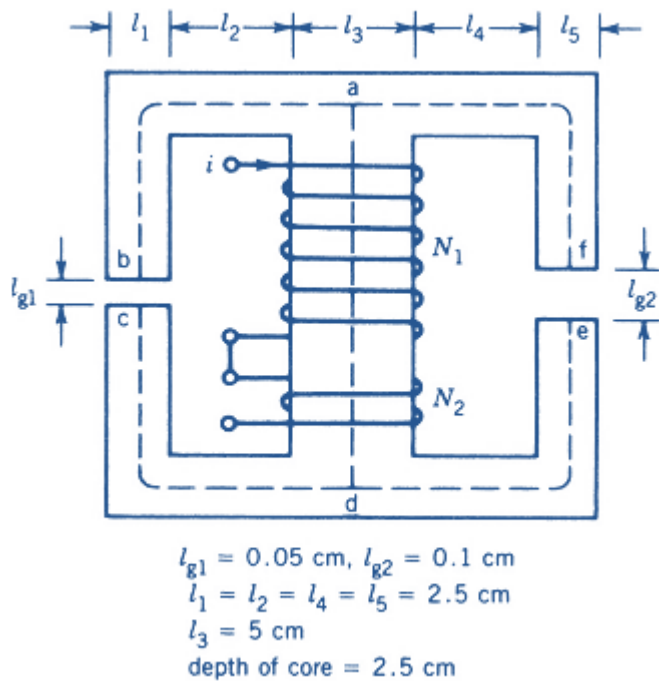

Figure 8

7-A coil wound on a magnetic core is excited by the following voltage sources.

(a) 100 V, 50 Hz.

(b) 110 V, 60 Hz.

Compare the hysteresis losses and eddy current losses with these two different sources. For hysteresis loss, consider  $n=2$ .

8-A toroidal core of mean length 15 cm and cross-sectional area  $10 \text{ cm}^2$  has a uniformly distributed winding of 300 turns. The B-H characteristic of the core can be assumed to be of rectangular form, as shown in Fig. 9. The coil is connected to a 100 V, 400 Hz supply. Determine the hysteresis loss in the core.

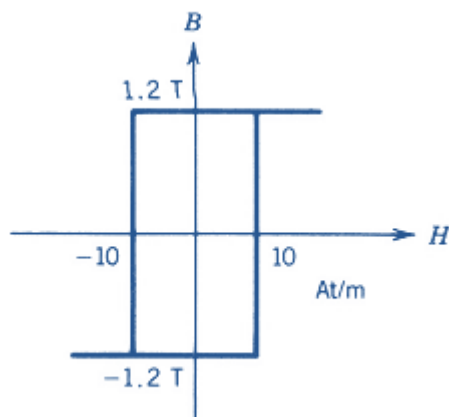

Figure 9