

CTI Journal

The Official Publication of the Cooling Technology Institute

Air Cooled Condensers

Cooling Towers

Fluid Coolers

Evaporative Condensers



Est. 1950

COOLING TECHNOLOGY
INSTITUTE

www.cti.org



Thermal Certification **Education** CTI Codes & Standards

Technical Information Exchange

Research Water Chemistry **Testing** Thermal Software

Webinars
Technical Conferences
Educational Issues
CTI Newsletter
CTI Awards
Cooling Tower Manual
CTI Technical Papers



www.cti.org

Winter 2016
Volume 37, No. 1

Are you
still doing
this...



And ending
up with
this?

Call on the Screening Experts

Replace your existing bar screens on line, without any basin modifications with our unique, continuous screening

**Vari-Flow SS Series
Traveling Sump Screen**



Traveling Sump Screen

The Vari-Flow SS Series Traveling Sump Screen is custom fabricated to easily replace stationary screens while your unit stays in full operation. The screens can be automated and are available in more than 20 different screen-mesh sizes. The Traveling Sump Screen is patented, manufactured and distributed by Industrial Cooling Tower Services. Let the experts handle your equipment screening needs with this easy-to-use, cost efficient solution.



Industrial Cooling Tower
SERVICES, INCORPORATED

(225) 387-5664 • www.ictsinc.com

MISSION STATEMENT

As a broad based industry association, our mission is to advocate and promote, for the benefit of the public, the use of all environmentally responsible, cooling technologies, such as wet cooling towers, air-cooled condensers, dry coolers, indirect cooling, and hybrid systems, by encouraging:

- Education on these technologies
- Development of codes, standards, and guidelines
- Development, use, and oversight of independent performance verification and certification programs
- Research to improve these technologies
- Advocacy and dialog on the benefits of cooling technologies with Government Agencies and other organizations with shared interests
- Technical information exchange

LETTERS/MANUSCRIPTS

Letters to the editor and manuscripts for publication should be sent to: The Cooling Technology Institute, PO Box # 681807 Houston, TX 77268.

SUBSCRIPTIONS

The CTI Journal is published in January and June. Complimentary subscriptions mailed to individuals in the USA. Library subscriptions \$45/yr. Subscriptions mailed to individuals outside the USA are \$45/yr.

CHANGE OF ADDRESS

Request must be received at subscription office eight weeks before effective date. Send both old and new addresses for the change. You may fax your change to 281.537.1721 or email: vmanser@cti.org.

PUBLICATION DISCLAIMER

CTI has compiled this publication with care, but CTI has not Investigated, and CTI expressly disclaims any duty to investigate, any product, service process, procedure, design, or the like that may be described herein. The appearance of any technical data, editorial material, or advertisement in this publication does not constitute endorsement, warranty, or guarantee by CTI of any product, service process, procedure, design, or the like. CTI does not warranty that the information in this publication is free of errors, and CTI does not necessarily agree with any statement or opinion in this publication. The entire risk of the use of any information in this publication is assumed by the user. Copyright 2016 by the CTI Journal. All rights reserved.

Contents



Feature Articles

- 8 **Outside/Inside Approach to Evaluating Concrete Elements in Natural & Mechanical Draft Cooling Towers**
Thomas Kline
- 14 **Managing Machinery Assets Using Predictive Maintenance A Manager's Overview**
David A. Corelli
- 30 **An Alternative Approach To Disinfection Using Chlorine Dioxide**
Ingmar Hermans and Vincent van Camp
- 42 **From Vision To Practical And Cost Effective Design**
Roy A. Holliday, Shereif Alsayed and Amr Eladawy
- 50 **Study on the Combustion of Polymers Within Cooling Towers**
Chris Bowman and Jia Shen
- 62 **Alternative to Bromine Improves Cooling Water Microbial Control and Overall Treatment**
Andrew Boal
- 70 **The Impact of Ionic Strength Upon Inhibitor Speciation and Efficacy**
Robert J Ferguson
- 78 **Improve System Performance and Reduce System Corrosivity Using a Novel Biocide for Cooling Towers**
Chris Baron and Stephanie Hammond

Special Sections

- 83 CTI Licensed Testing Agencies
- 84 CTI Certified Towers
- 90 CTI ToolKit



.....see page 8

Departments

- 2 Multi Agency Press Release
- 2 Meeting Calendar
- 4 View From the Tower
- 6 Editor's Corner
- 6 In Memorium



.....see page 66



.....see page 20

Journal Committee

Paul Lindahl, Editor-in-Chief
Art Brunn, Senior Editor
Virginia Manser, Managing Director/Advertising Manager
Donna Jones, Administrative Assistant
Andrew Manser, Administrative Assistant
Angie Montes, Administrative Assistant
Graphics by Sarita Graphics

Board of Directors

Bill Howard, President
Anthony DePalma, Vice President
Brandon Rees, Secretary
Steve Chaloupka, Treasurer
Billy Childers, Director
Jon Cohen, Director
Jim Cuchens, Director
Narendra Gosain, Director
Brian Hanel, Director Elect
Natasha Jones, Director
Jean-Pierre Libert, Director Elect
Frank Michell, Director Elect
Helene Troncin, Director

Address all communications to:
Virginia A. Manser, CTI Administrator
Cooling Technology Institute
PO Box #681807
Houston, Texas 77268
281.583.4087
281.537.1721 (Fax)

Internet Address:
<http://www.cti.org>

E-mail:
vmanser@cti.org

For Immediate Release

Contact: Chairman, CTI Multi-Agency Testing Committee

Houston, Texas, 3-May-2016

The Cooling Technology Institute announces its annual invitation for interested drift testing agencies to apply for potential Licensing as CTI Drift Testing Agencies. CTI provides an independent third party drift testing program to service the industry. Interested agencies are required to declare their interest by July 1, 2016, at the CTI address listed.

FUTURE MEETING DATES

Committee Workshop

July 10-16, 2016
Pointe Hilton Tapatio Cliffs
Phoenix, AZ

July 16-19, 2017
Hilton Orlando – Lake Buena Vista
Lake Buena Vista, FL

Annual Conference

February 5-9, 2017
Sheraton New Orleans
New Orleans, LA

February 4-8, 2018
Hilton Houston North
Houston, TX

Step up to the “Vari-Flow” Distribution Valve



Internal Guide & Support System

The “Vari-Flow” Distribution Valve has been designed with a superior internal guide system that supports the stem and disc providing support needed to allow the valve to be used for balancing flow.

Maintenance Free Operation

Manufactured from 304 stainless steel and UHMW plastic, which eliminates corrosion and maintenance concerns. Bushing assembly replaces easily from exterior, eliminating costly downtime.

Positive Shutoff

An improved gasket system allows complete (positive) shut-off of the water stream without the persistent leaking associated with conventional valves.



Industrial Cooling Tower

S E R V I C E S , I N C O R P O R A T E D

(225) 387-5664 • www.ictsinc.com



Swifter CTX Series

The next generation of industrial fans
for cooling towers and
heat exchangers.

swifterfans.com

GLOCON INC • NJ USA • 973-463-7300

Swifter[®]
Efficiency. Performance. Innovation.

View From The Tower

What better way to ring in a new year than with the CTI Annual Conference? This year's conference is being held in Houston, a familiar locale for many members and home of the CTI office itself--an office that has worked hard to prepare yet another great program full of technical presentations, seminar, panels, committee meetings, exhibits, and of course educational and professional development opportunities. Everyone takes something valuable away from the CTI Annual Conference, from owners and operators to manufacturing and supply representatives, and even students and consultants, appearing in the CTI directory for the first time this year. Indeed I am eagerly looking forward to this year's conference, and I want to welcome both new and long standing members to Houston as we prepare for another productive year of growth, expansion, and education.

As you all know by now, each year the nine member CTI board of directors says goodbye to three members and welcomes three new ones. This year, I would like to personally extend my thanks and good tidings to Billy Childers, Aggreko Cooling, Steve Chaloupka, Amarillo Gear and Natasha Jones of Bechtel Power; your service and devotion to CTI's health and operations is greatly appreciated. And I would ask you all to join me in welcoming to Brian Hanel of Hudson Products, Jean Pierre Libert of Evapco, Inc., to their new positions on the board where we look forward to your fresh



Frank Michell

and successful terms. The CTI membership has also elected me to serve on the Board representing the Owner Operator category. CTI has grown tremendously over the past several years, and without the care and attention of our board of directors, it would be a ship likely lost at sea.

It is important, though, that we try and not forget the individual members that have always and continue to make CTI a world class technical organization. The individual contributions of our volunteers is without equal, and the bonds of business, partnership, and even friendship are hard to miss during our conference. With that said, that I would like to extend a heartfelt thanks to Bob Lindley for his years of service and professional involvement in CTI and my most sincere condolences to both his family and

friends Bob was a highly respected member of CTI serving in various capacities since the 1980's, Bob will be missed.

Finally, a thank you to the CTI staff for their work in performing the CTI day-to-day operations and production of this annual conference, and congratulations on the successful launch of its very own standalone conference application.

Sincerely and respectfully,

Frank Michell

CTI President

2014-2015

The best sheaves for the worst environments!

Ideally suited for the most aggressive atmospheres, unusual conditions, such as weight requirements and installation problems, Bailsco lightweight all-aluminum cast V-belt sheaves have been in the field for over 15 years.

Full range of sizes available up to 38" diameter, larger sizes available upon request. Special designs to meet OEM requirements.

Design, molding, casting, machining, heat treating and balancing are all done "in-house".

BAILSCO
POWER TRANSMISSION PRODUCTS

BAILSCO BLADES AND CASTINGS, INC.
Box 6093, Shreveport, LA 71136-6093 U.S.A.
Phone 318.861.2137 FAX 318.861.2953
www.bailsco.com
email: bailsco@bailsco.com



Quality, Innovation, and Superiority since 1939.

ACC Fan Problems?

**Not all FRP is equal.
Tuf-Lite® is the answer.**

Major 45 cell ACC in Colorado suffered numerous fan failures, even with wind screens. Customer replaced all 45 cells with Hudson Tuf-Lite® and experienced the following:

- 13% more airflow at 10% less horsepower.
- Major RELIABILITY improvement
- Safety improvement



Hudson Products Corporation
9660 Grunwald Road
Beasley, TX 77417-8600
281-396-8179

Editor's Corner

Dear Journal Reader,

During the CTI Annual Meeting in February, 2016, the term of Frank Michell of AEP as President of CTI will expire. It seems appropriate to take a moment and reflect on this. I believe that Frank is the first person to have served as CTI President both under the original format and under the new format. Under the original format, the President was elected for a 1 year term from among the 9 board members. Under the new format, the presidential candidates go through a nomination process and are elected as President (and Chairman of the Board) for a 2 year term. The voting membership of the Board is separate, and the President only votes in the event of a tie, which is unlikely with 9 Board members. Frank has been an active Owner/Operator category participant in CTI for as many years as I have, which is a lot. Frank, however, has been a critical and irreplaceable O/O in many of the ongoing activities of CTI for which balance or independence is essential. He has been a steadying influence on a sometimes volatile organization as well as being an effective leader. I thank him for his many years of contribution (ongoing), and encourage as many of you as possible to do the same. I'm sure Frank would join me in advocating that other Owner/Operators get involved in CTI, as their potential value to the organization and industry is very significant.

Some key updates:

DOE Fan Rule: My last Editor's Corner attempted to make CTI Members aware that a Department of Energy rulemaking is in progress with regard to fans, which includes at this point the manufacturers of cooling towers, closed circuit coolers, evaporative condensers, air cooled heat exchangers, air cooled refrigerant and steam condensers, and any hybrid of the above that moves air with a fan or blower. A working group of CTI members under the



Paul Lindahl
Editor-in-Chief

Strategic Issues Task Force developed a position paper which was filed with the DOE, and led to CTI representation (Larry Burdick (SPX, member), and Frank Morrison (BAC, alternate) on a negotiation working group under DOE auspices. The target date for closure on their activity was early August, 2015. CTI has asked for exemption of heat rejection equipment from the rule, and up to this point have been successful in gaining the exemption in the term sheet agreed upon by the working group. The DOE is writing the final rule, so we will need to continue to watch this closely. CTI members who produce fans for any purpose should be aware that they could be affected by this rulemaking, which will set minimum fan efficiencies by equipment types. For more information, contact Larry Burdick, Frank Morrison, or me.

CTI Research Update: A research grant was awarded to CleanAir, from amongst those who responded to the CTI RFP, to complete Pitot tip investigations to find a replacement for the (no longer commercially available) Simplex tip, which has been the CTI water flow measurement standard. CleanAir is currently proceeding with the project. For those who may be unfamiliar with this, it is the first research project developed under the relatively new CTI Research and Development Committee. Projects are proposed via the standing technical committees, and proceed through a process administered by the R&D committee. Funding is raised and administered via the CTI Finance Committee. Other projects are under consideration, and new ones may be proposed within the standing technical committees at any time.

There is much happening with the very active CTI volunteer technical organization; we again encourage you to get involved in the CTI technical committees.

Respectfully,

Paul Lindahl, CTI Journal Editor

In Memorium John Robert Lindley



John Robert Lindley, 71, was born on February 18, 1944 in San Angelo, Texas and passed away on January 11, 2016 in Houston, Texas. He graduated from Permian High School in Odessa, TX in 1962, and attended Texas Tech University. He was Consultant and Design Engineer, and a Member of Cooling Technology & CTI for over 25 years, and a former Committee Member of CTI, along with other professional organizations. Bob was also a Lifetime Member of the Houston Livestock Show & Rodeo. Bob's passions were his family first, He was avid car vintage car collector with emphasis on Chevrolet Corvettes; he enjoyed cooking, Entertaining...

In Memorium Marcel Lefevre



It is with great sadness that we report the death of our colleague and friend Marcel Lefevre. Marcel was known worldwide for his knowledge of water cooling technology and his willingness to share that knowledge. Countless individuals and many companies relied on Marcel for help and guidance in the thermal design and evaluation of cooling towers and other heat transfer equipment.

Marcel is survived by his wife and essential business partner Nicole, his children George, Michel, Veronique and three grandchildren.

The family asks that donations to Hope Hospice of Fort Myers be made in lieu of flowers. Checks can be mailed to: Hope Hospice, 9470 HealthPark Circle, Fort Myers, FL 33908 or donate on the web at www.hopehcs.org/donate/ or call (855) 454-3104



*USA
Facility
Coming Soon!*

Manufacturing Quality FRP for the Americas

FasTec has been producing high quality FRP Products for over 15 years. Quality FRP shapes, decking that meets and exceeds CTI Standards. All of our structural shapes utilize a 12 mil veil - standard. FasTec Produces a Full Line of FRP Grating to include R-8310, I6015, Stair Treads & Stair Tread Covers.

Call Today Toll Free: 1-800-309-7271

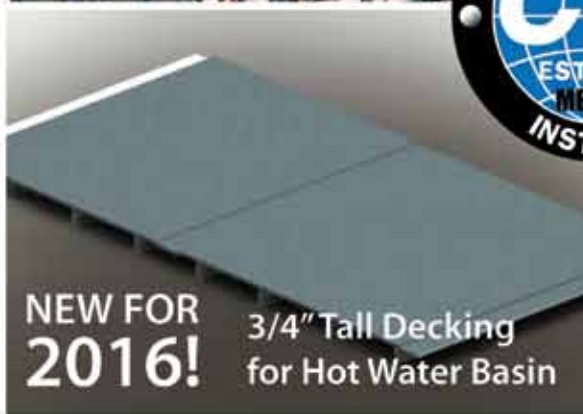

**NEW FOR
2016!** 3/4" Tall Decking
for Hot Water Basin



**HOUSTON, TEXAS USA
832-867-2228**

**ZAPOPAN, JALISCO MEXICO
52-333-560-6031**

WWW.FASTECINTERNATIONAL.COM

Outside/Inside Approach to Evaluating Concrete Elements in Natural & Mechanical Draft Cooling Towers

Thomas Kline
Structural Technologies



Thomas Kline

The condition of an operating Cooling Tower's reinforced concrete structural elements always seem to be a mystery until it's brought down, cleaned and then closely examined by professionals with specific evaluative expertise. Whether Natural or Mechanical Draft in function, Cooling Tower assets are typically the last equipment to be brought down during a short-duration outage and then the first equipment brought up during re-commissioning. To address this "Catch-22" in understanding the condition of these critical assets, an innovative Condition Assessment approach has been developed. The approach employs on-line/off-line tactile evaluative techniques that include Non-Destructive Testing (NDT) and Semi-Destructive Testing (SDT) to better understand the condition of reinforced concrete structural components.

Background & Multi-Phase Process

Maintenance personnel have a particularly difficult job when it comes to preparing Fiscal Budgets for assets that are only partially understood regarding their condition and whether they are "fit-for-service". Recognizing that some exterior surface areas of the reinforced concrete foundation and super-structure, are accessible from the "outside" while the Cooling Tower is on-line, an opportunity exists to initiate an investigation by incorporating NDT evaluative tools such as:



Figure No. 1 Deterioration mapping of observed exterior structural concrete members

- Review of Archival Documents (i.e., original construction drawings, specifications, inspection records, make-up water requirements & analysis, etc.)

- Visual Examination & Mapping as seen in Figure No. 1
- Acoustic Impact (ASTM D4580/D4580M-12) Hammer Sounding¹ as seen in Figure No. 2
- Ground Penetrating Radar (ASTM D6432-11)²
- Rebound Hammer (ASTM C805-13a)³ as seen in Figure No. 3

The advantage of performing the Phase 1 NDT techniques listed above is that no intrusive means & methods are used such as drilling or coring which could possibly breach containment Wall sections and potentially initiate a thru-wall cooling fluid leak. The information gathered by this limited NDT effort can provide insight into as-constructed

compliance with original construction documents. Also, obvious defects can be detected by close visual observation and surface hardness determinations can often detect whether or not consistent concrete mixes were incorporated into original construction which can be an indicator as to whether a high quality effort was in-place at the time of original construction. The development of "trends" from collected data is an important feature of any investigation. However, NDT by its very nature requires validation otherwise "garbage-in generates garbage-out", an axiom that holds when unsubstantiated data is unquestioned and decision-making effectiveness is diminished by poor quality information.



Figure No. 2 Hammer sounding of concrete member repairs.

Information collected during the Phase 1 outside on-line portion of the investigation generally takes the form of deterioration mapping. Significant features such as cracking and its characterization (i.e., width, faulting, leakage, etc.) (Figure No. 4), staining, embedded steel bar orientation & compliance to original detailing, observed



Real experts, real results

Proven Treatment Technologies For:

Cooling Systems
Pretreatment
Boilers
Wastewater
Membranes & RO
Automation & Control

The Best People

Experienced service engineers who live in your community

Results That Last

Extending asset life while minimizing chemical and water usage

Continuous Innovation

Delivering customized products with a full-service analytical lab and R&D group

Environmental Protection & Safety

Protecting your people, your brand, and the environment with our innovative solutions

Phone number: 804-935-2000
Website: www.chemtreat.com



surface erosion (Figure No. 5), leakage adjacent to construction/expansion joints (Figure No. 6), failed previous repairs (Figure No. 7) and the presence of standing water or unusual soil formations (i.e., humps, rills, gullies, etc.) next to exterior Basin Wall regions are recorded on field drawings. Often, this information can be sufficient for Maintenance personnel, allowing them time to acquire and secure funding for a repair program within their outage maintenance budget. Once an opportunity becomes available during a short-duration outage, the Cooling Tower Basin is drained and then water-blasted clean for purposes of examining interior concrete surfaces of the Walls, interior support Columns and Base Slab regions. Additionally, associated construction details such as interior construction/expansion joints are closely examined for integrity. Using similar on-line NDT techniques in Phase 1, as well as sample collection for “truth & verification” and identification of concrete material properties, significant information can be quickly collected and relayed to interested parties during Phase 2 evaluation activities.



Figure No. 3 Rebound Hammer Testing for surface hardness assessment.



Figure No. 4 Crack Comparator measurement of crack widths

Phase 2 SDT Techniques performed off-line can include:

- Concrete Core Sampling (ASTM C42/C42M-10a)⁴ as seen in Figure No. 8
- Inspection Windows for reinforcing and embedment details:
 - o Laboratory Testing of collected core samples:
 - Concrete Compressive Strength (ASTM C39/C39M-10)⁵
 - Depth of Carbonation (Phenolphthalein Indicator Solution)⁶
 - Water-Soluble Chloride Content (ASTM C1218/C1218M-99 Reapproved 2008)⁷
 - Alkali Silica Reactivity Testing (Los Alamos – UAR-Uranyl Acetate Reagent Testing)⁸

It’s at this time when rapid decision-making processes take place to determine whether repair strategies fall within the scheduled outage time frame and budget allowances. Should serious conditions be encountered during an outage inspection, temporary means & methods can sometimes be employed (i.e., shoring/stabilization programs) or more permanent solutions implemented (i.e., reinforced concrete repair and protection) as these critical assets rarely come off-line.



Figure No. 5 View of eroded exterior concrete Basin Wall surfaces adjacent to the Chemical-Charging Station.

As part of the deliverables associated with each Phase of the Outside/Inside Approach to Evaluating Cooling Towers, a written report should be expected with the Phase 1 outside or pre-outage inspection accompanied by an Order-of-Magnitude Repair Cost for Maintenance personnel so they can plan and secure funding for repairs believed to be present and requiring work during the short-duration outage. The Final Inspection Report associated with Phase 2’s inside or outage inspection is initially relayed via an on-site verbal Debriefing with a comprehensive report submitted as an archival “as-built” document subsequent to repairs and re-commissioning of the Cooling Tower. The written report typically includes:

- Background and Project Understanding
- Field Investigation and Testing
- Data Analysis
- Findings and Recommendations
- Order-of-Magnitude Repair Costs



Most cooling tower shapes in stock & ready for immediate shipment, including:

- 3 ½" EXTREN® Channel
- 3 ½" EXTREN® Square Tube
- 3 ½" x 5 ½" EXTREN® Rectangular Tube
- 5 ½" EXTREN® Channel
- 1 ¼" deep SAFDECK®

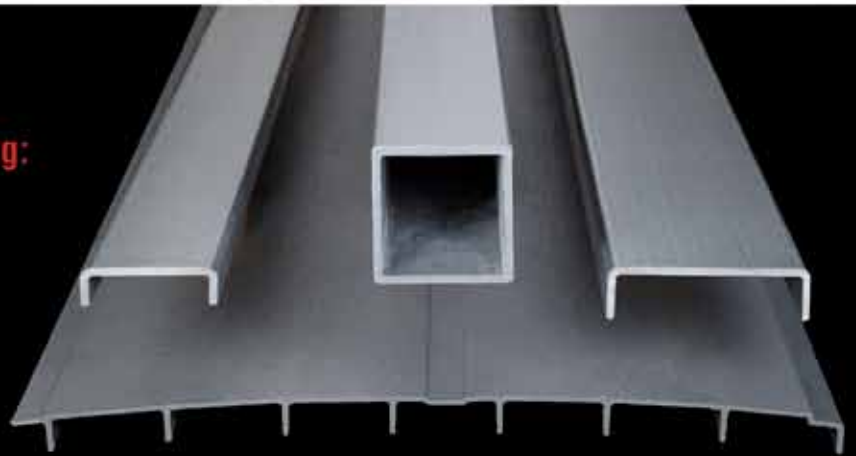

Sign up to access the most
up-to-date design information at:
www.strongwell.com/designmanual

STRONGWELL PRODUCTS ARE PROUDLY
 **MADE IN THE
USA**

**ISO-9001:2008 Quality Certified and ISO-14001:2004
Environmentally Certified Manufacturing Plants**

This multi-phase investigative model has proved to be a highly effective tool for Maintenance personnel unaware and ill-equipped at developing repair budgets for assets that are rarely available for inspection and have the majority of the infrastructure hidden by process media.



Figure No. 6 Failed Expansion Joint.



Figure No. 7 View of failed precast concrete repairs on exterior Canopy Panels.



Figure No. 8 Concrete core sampling of a Natural Draft Hyperbolic Cooling Tower Veil.

Case History

Project: Multiple Mechanical Draft Wood Construction Fill Cooling Tower Basins

Owner: Petroleum Refiner

Location: Southwestern USA

Deterioration: Cracked, leaking and spalled concrete Cooling Tower Basin Walls

Background:

Several Mechanical Draft Cooling Towers were experiencing significant leakage requiring regular “make-up” cooling water additions for losses associated with actively leaking joints and cracks in the Cooling Tower Basin. Attempts at sealing observed leakage conditions while the Cooling Towers were on-line were largely unsuccessful (refer to Figure No. 9). Substantial reinforced concrete Basin Wall section losses were observed concerning Maintenance personnel as well as Refinery Leadership (refer to Figure No. 10). The Owner realized that a more thoughtful restoration program would be needed than unsuccessful “patch” repair attempts employed in the past. Coinciding with a scheduled refinery-wide maintenance outage, a comprehensive evaluation program was developed that began with on-line assessment activities focusing on evaluating outside Basin Wall deterioration of several Cooling Towers.

The Phase 1 pre-outage outside assessment started by assembling accurate as-built drawings required as original construction documents were unavailable. Deterioration manifestations were located on the as-built drawings as well as significant features. Based on collected data, prevailing environmental factors such as Cooling Tower drift and chemical charging locations visually appeared to be contributing factors to the observed distress. These locations were targeted for Phase 2 off-line inside assessment efforts to validate assumptions developed during the Phase 1 evaluation.

Once the scheduled outage began, the Phase 2 inside assessment began in earnest with the Basin water-blasted clean for visual examination, acoustic impact testing as well as concrete core sampling. Internal assessment activities validated Basin Wall full-section deterioration necessitating partial height wall removal and replacement as well as reconstruction of existing waterstops as shown in Figure Nos. 11 through 13. Fortunately, Phase 1 detection of deterioration was able to provide the Owner with adequate budgeting information so that during the short-duration outage, repairs could be initiated and completed to multiple Cooling Tower Basins, simultaneously.



Figure No. 9 View of failed crack sealant repairs on exterior Basin Walls.



Figure No. 10 Extensive Basin Wall section-losses due to freeze-thaw damage and aggressive chemical attack.



Figure No. 13 Finished Basin Wall Repair after bringing the Cooling Tower back on-line subsequent to the short-duration outage.

Additional Investigative Opportunities

It should be noted that sophisticated restoration projects, such as large deteriorated Natural Draft Hyperbolic Cooling Towers, may require more comprehensive evaluation strategies than discussed in this paper. Investigative techniques such as embedded metal corrosion surveys, structural analysis and life cycle cost analysis may be necessary to more accurately understand ongoing deterioration resulting from complex distress manifestations requiring very specific expertise beyond standard maintenance and repair in kind. It's recommended that restoration professionals be retained that have demonstrated specific expertise at developing and implementing full scale evaluative strategies and executing innovative restoration programs for these complex deterioration scenarios.

References

1. ASTM D4580/D4580M-12: Standard Practice for Measuring Delaminations in Concrete Bridge Decks by Sounding, ASTM International, West Conshohocken, PA, 19428-2959, USA
2. ASTM D6432-11: Standard Guide for Using the Surface Ground Penetrating Radar Method for Subsurface Investigation, ASTM International, West Conshohocken, PA, 19428-2959, USA
3. ASTM C805-13a: Standard Test Method for Rebound Number of Hardened Concrete, ASTM International, West Conshohocken, PA, 19428-2959, USA
4. ASTM C42/C42M-10a): Standard Test Method for Obtaining and Testing Drilled Cores and Sawed Beams of Concrete, ASTM International, West Conshohocken, PA, 19428-2959, USA
5. ASTM C39/C39M-10: Standard Test Method for Compressive Strength of Cylindrical Concrete Specimens, ASTM International, West Conshohocken, PA, 19428-2959, USA
6. ASTM C856-11: Standard Practice for Petrographic Examination of Hardened Concrete, ASTM International, West Conshohocken, PA, 19428-2959, USA
7. ASTM C1218/C1218M-09 (Reapproved 2008): Standard Test Method for Water-Soluble Chloride in Mortar and Concrete, ASTM International, West Conshohocken, PA, 19428-2959, USA
8. ASTM C33/33M-11: Standard Specification for Concrete Aggregates, APPENDIX X1.3 Alkali-Silica Reaction, ASTM International, West Conshohocken, PA, 19428-2959, USA



Figure No. 11 Excavation of deteriorated Basin Wall concrete materials.



Figure No. 12 Basin Wall Formwork incorporating corrosion-resistant form-tie hardware.

Managing Machinery Assets Using Predictive Maintenance A Manager's Overview

David A. Corelli, Imi Sensors/Vibration Institute

Abstract

Much of the content, case histories, and figures for this paper were supplied by the author's colleagues at the Vibration Institute and for that I am appreciative. The paper also encompasses the authors 40 years of experience in vibration analysis, condition monitoring, and personal experience in what makes programs successful or fail. This paper is intended as an overview for managers and supervisors that would like to know more about the benefits, cost, and commitments required for starting a predictive maintenance program; how to determine if such a program will benefit their company; and if so, how to get started.

Vibration Institute

The Vibration Institute is a not-for-profit professional organization that is "Dedicated to the dissemination of practical information on evaluating machinery behavior". It provides training and certification in the field of vibration analysis and condition monitoring of rotating machinery and works with both ANSI and ISO committees in the development of pertinent standards in these areas.

Introduction

Today's literature is littered with information on Reliability Methods such as Predictive, Preventive, Proactive Maintenance, Condition Monitoring, Asset Management and Reliability Centered Maintenance and it is often difficult to distinguish where one ends and the other begins as it relates to machinery health and availability. As it turns out, this author believes they have a lot of overlap. In the end, they all imply doing what is necessary to ensure that a machine keeps on working, adequately performing its intended function, and without experiencing unexpected downtime or catastrophic failure.



David A. Corelli

Disaster

On August 1, 2007 disaster struck the 8-lane, I-35W Bridge over the Mississippi River in Minneapolis when it collapsed during the evening rush hour killing 13 people and injuring 145, Figure 1. We all know that disaster can strike at any time, without warning, and have terrible consequences. This purpose of this paper is to show that in many cases, particularly on rotating machinery, monitoring systems can be put in place to avoid unexpected failure and disaster.

Investigation by the NTSB and others determined that the collapse was caused by undersized gusset plates that were inadequate to support the intended

load of the bridge. [1] An obvious question to ask is could this disaster have been avoided if the bridge had been instrumented with a monitoring system? That is a question to be answered by structural and civil engineers, but most likely, no one can say for sure. However, in order to monitor the bridge or any other structure or machine, the appropriate parameter or parameters must be identified and monitored properly if faults are to be detected prior to a failure. The trick is to choose a parameter that provides reliable health information on the machine or structure, to monitor it regularly, and then to act upon a warning. This paper discusses how to do this on rotating machinery.

Monitor The Right Parameter: It was stated above that it is possible that the bridge collapse or many other failures could be detected if the proper parameter can be identified and monitored on a regular basis. That is not necessarily as easy as it sounds. This example illustrates how the parameter selected matters in detecting a fault.

Consider the case of a typical centrifugal pump with a faulted rolling element bearing. Figure 2 shows three overall vibration trend plots of data collected with a wireless vibration system that only collects overall data. It should be noted that all three trend plots were generated from data collected with the same sensor, mounted at the same location, and at the same time on the pump. The data were processed differently to show the different measured parameters.



Figure 1: Photo of Minnesota bridge collapse [2]

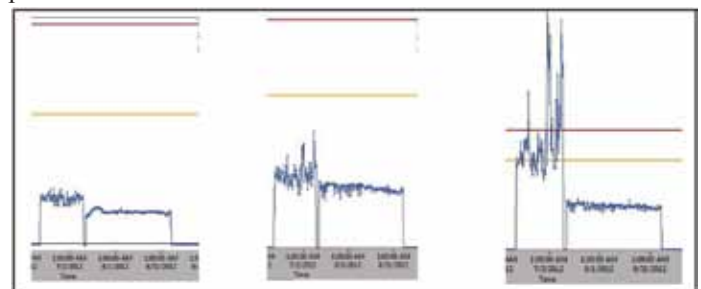

Figure 2: Velocity, acceleration, and true peak acceleration plots of a faulted bearing

DO YOU MEET THE CTI STANDARD?

Our Electronic Vibration Switches Help Cooling Towers Meet the Updated CTI Vibration Limits Standard



Electronic Vibration Switches
Series 685B

USB 
PROGRAMMABLE
SMART Vibration Switch
Series 686C

P.S. No mechanical vibration switch can make that claim

Check it out.

Get a quote.

Buy online.

The overall vibration trend plots in Figure 2 that include warning and critical alarm levels are, in order, rms velocity, rms acceleration, and a high pass filtered true peak acceleration. It is clearly seen that true peak acceleration is the parameter that is most sensitive to the bearing fault. If this measurement had not been monitored, it is not clear that the fault would have been caught in time. Some predictive maintenance programs use velocity trends as their primary indicator of a developing fault. With today's fast and capable systems, there is no reason not to monitor and trends all pertinent parameters.

Monitoring Techniques and Asset Management: While there are many valuable and viable techniques for monitoring the condition of rotating machinery and rolling element bearings, such as Thermography, Oil Analysis, Ultrasonic Analysis, and Acoustic Emission Monitoring, this paper is focused on monitoring Vibration as a measure of machinery condition. Thus, Assets (machinery) will be managed using Predictive Maintenance of which Condition Monitoring is a key factor. This becomes an input that drives Reliability Centered Maintenance since maintenance actions, in part, are dictated by the results of the Predictive Maintenance program results.

There are many aspects to Predictive Maintenance and Asset Management of production equipment. Some are relatively easy to implement and some extremely difficult. Basic Predictive Maintenance programs can be put into place with relatively little experience while robust programs require dedicated and highly trained individuals. While the benefits to any well run program will generally more than offset the cost of such a program, it can be a daunting task for management to approve one considering the startup costs, training requirements, commitment of personnel, non-familiarity with the science, and not knowing where to start.

This paper will attempt to answer the questions: why do it, what does it cost, how much training and commitment is required to achieve success, and how does one get started?

Why Monitor Equipment

Consider a critical overhead crane in a metal processing plant whose operation is required to produce over \$1 MM worth of product a day. Consider also that when the crane is down, much of the lost production cannot be made up. How much is it worth to the company to monitor the crane so it can be taken down for maintenance at a convenient time when both parts and personnel are available for a quick fix, rather than have a catastrophic failure that will probably cause additional damage to the machine resulting in it being down for several days and costing more in repairs, personnel time, and downtime?

Figure 3 is a simple trend plot showing that the overall vibration (rms velocity) increased from around 1 ips (inch per second) to about 3 or 4 ips. When the unit was inspected, the brake/clutch assembly was clearly about to fail and maintenance crews were able to make necessary repairs in just a few hours. In this case, the use of simple overall level monitoring was sufficient to catch this fault, avoid a potentially dangerous catastrophic failure, and save hundreds of thousands of dollars, perhaps millions, in lost production. Are they all this easy to catch? Of course not, but with simple monitoring and trending, you'll catch many faults, which is better than catching none!

Note: The data in the trend plot is somewhat erratic because it was collected with a wireless vibration system that transmits measurements on a pre-programmed time interval. Thus, low levels readings are received when the crane is not operating and higher levels when it is. Even with this limitation, it was clear that the vibration had gotten much worse.

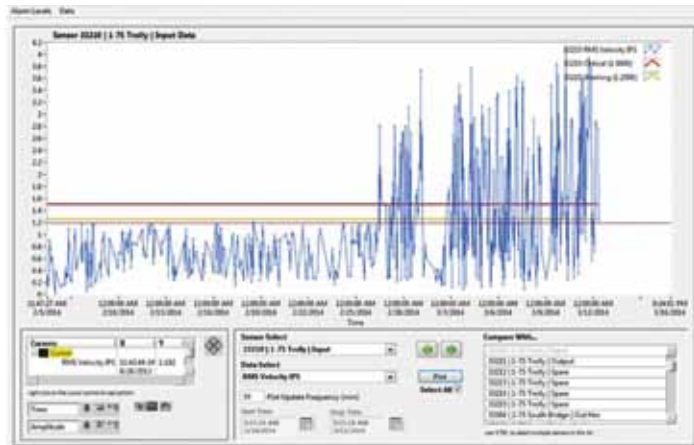

Figure 3: Trend plot of overhead crane overall vibration data

Monitoring to catch these types of potential failures may seem like a “no brainer” but many companies experience these types of failures and losses all the time and do nothing to improve, probably because they don't know where to start. This paper attempts to show how to start, improve, and develop a first class Predictive Maintenance program.

In this author's opinion, it takes 4 key elements, listed below, to start and run an effective predictive maintenance program. In this author's experience, the biggest stumbling block and why many programs fail is lack of ongoing commitment. Once the original purchase is made, ongoing support of the program is critical to its success. That includes support of ongoing training for the people involved and for system updates.

- justification (fiscal and technical)
- dedicated people (it can't be done in your “spare time”)
- investment in tools and training
- ongoing commitment to the program and training

How Bad Can It Get

On August 17, 2009 at the Sayano- Shushenskaya Hydroelectric Power Station in Khakassia, Russia, a turbine broke apart violently killing 75 people, damaging 9 out of 10 turbines and lost the entire plant's output of 6400 MW leading to widespread power failure, see Figures 4A and 4B. The official report on the accident stated “the accident was primarily caused by the turbine vibrations which lead to the fatigue damage of the mountings of the turbine”. It went on to say, “It was also found that at the moment of accident at least six nuts were missing from the bolts securing the turbine cover.” [3] How difficult, how much time, and what would the cost have been to replace the nuts on six bolts? One of the functions a technician is trained to do when running a route (collecting data on a predefined list of machinery) is to inspect the machine for problems such as oil leaks, loose belts, and missing nuts on bolts! These types of problems are recorded and reported with the other data collected.

It appears from this report that a vibration monitoring program would have caught the problem, and perhaps even did. However,

in order for a predictive maintenance program to be effective, when a problem is identified someone needs to act upon the diagnosis, not ignore it, to avoid a catastrophic failure. This obviously did not happen. As is typical in many plants, production rules and companies continue to run equipment they know may fail but hope they don't. Sooner or later something will fail, the only questions are when and how big will the consequences be?



Figure 4A & 4B: Severe damage at the at the Power Station [4, 5]

In this author's experience, when it comes to plant operations it seems there is always time and money available to put out a fire but there is often no time or money available to prevent one. In the end, even seemingly small failures can lead to big consequences. So, it boils down to this question, "How much risk are you willing to take?"

Success planning

Don't wait until disaster strikes before you change. Or, as Jack Welch, former CEO of GE said, "Change before you have to."

Predictive Maintenance: What if there was a relatively simple process that would alert you to a developing problem in a critical production machine? What if this alert gave you enough warning not only to determine what the problem is but also to order the parts and schedule the people necessary to repair it? What if this warning also gave you the luxury to schedule the maintenance during a planned outage rather than at an inopportune time? This is Predictive Maintenance and it has been used successfully in many industries for decades, yet many companies still avoid it.

Condition Monitoring: Condition monitoring is an important component in Predictive Maintenance. It is the process of monitoring and trending one or more parameters, such as vibration, oil particles, and/or temperature that indicate when a fault is developing in a machine. When the parameter indicates a problem is developing, it allows maintenance to be scheduled and thus avoiding machinery failure and lost production. When this is done on a regular basis, it allows trained personnel to make informed decisions on the availability of machinery assets, which is what the production manager and management in general, want. If a program is to be successful, a trained analyst must translate data into useful information.

Diagnosis versus Prognosis: Figure 5 is a spectrum plot of a motor bearing showing both a BPFIF fault (inner race fault frequency) at 4.2 orders (4.2 x running speed) and a BPF0 fault (outer race fault frequency) at 3.2 orders and their harmonics (integer multiples of the fault frequency). There are also FTF (bearing train or cage frequency) sidebands present around the fault frequencies. This may as well be Greek or hieroglyphics to the average person and perhaps the reader.

Fortunately, a trained vibration analyst could easily diagnose this

as a bearing that is in pretty bad shape. The diagnosis in this case, is actually quite easy. The prognosis, on the other hand, is not so easy to determine. How long will it last? Even the best most experienced analysts can't say for sure, however, if you choose to leave it in service, you are waiting for disaster to strike! How much risk are you willing to take?

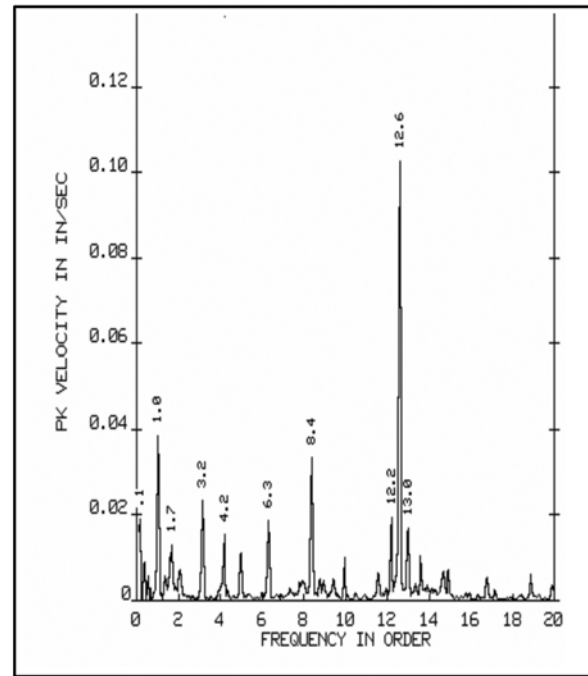

Figure 5: Spectrum plot of a bad motor bearing

Vibration Monitoring Systems

With today's technology, it would be hard to make a bad purchasing decision on a vibration monitoring system. Most major conferences involving condition monitoring equipment will have vendor areas showing a wide selection of vibration monitoring systems ranging from simple walk-around models to the most advanced online continuous monitoring systems. There are generally a lot of vibration consultants around the conferences as well that can provide advice on what you need if you just ask them. Attendance at such a conference, like the Vibration Institute's Annual Training Conference, is a great way to shop, compare, and learn.

There are three main components to a vibration monitoring system.

- Sensors, including cables and junction boxes
- Data collection device
- Monitoring/analysis software



Figure 6: The vb5 and 2140 are typical portable data collectors available in entry level to advanced configurations

The data collector or data collection device will have many options as will the software. The options selected will dramatically affect the cost of the system. Additionally, if you have machinery that requires permanently mounted sensors due to accessibility or safety concerns, then additional cost will be incurred for sensors, cabling, and junction boxes.

Sensors and Data Collectors: Before any assessment of a machine's condition can be made, data must be collected on a regular basis. Today's portable data collectors coupled with modern industrial accelerometers, Figure 6 and 7, make the collection of good vibration data relatively easy. Most predictive maintenance programs start out using a magnetically mounted accelerometer (typically included with systems) coupled with a portable data collector, Figure 8, to run routes and collect data. Most skilled trade personnel can learn to collect good vibration data quickly with a minimum of training. The key is to collect it on a regular basis and to look at it. Too often one hears stories about a failure that would have been caught if someone had just looked at the data they collected!



Figure 7: Typical top exit and side exit industrial accelerometers can be used with magnets for walk-around monitoring or permanently installed.



Figure 8: Data collection using a walk around data collector with a magnetically mounted high frequency accelerometer (photo courtesy of Praxair)

Permanently mounted sensors wired to junction boxes can be used for better data consistency, safer operation, and quicker data collection with walk around data collectors, Figures 9 and 10. They are also used with online, continuous monitoring systems. Dedicated continuous monitoring system, while more expensive, can provide immediate warning of a developing machine fault on highly critical machines and even shut down critical systems based on a pre-established shutdown (critical alarm) limits.



Figure 9: Permanently mounted accelerometer on a motor.



Figure 10: Data collection using a walk around data collector, permanently mounted accelerometers, and a junction box.

Vibration transmitters can be used to continuously monitor machinery using standard plant monitoring systems like a PLC, DCS, or PI system that accept a 4 – 20 mA signal, Figure 11. This may be preferable on a highly critical machine, especially if it has a short failure cycle. However, as stated above, most programs start with a simple walk around system, Figure 8.

Wireless vibration sensors and systems, Figure 12, are a new breed of monitoring systems that are starting to become popular. Unlike online systems that monitor continuously, these systems typically collect data and check it against alarm levels a few times a day. They have the advantage that they don't require any personnel to collect data on healthy machines (however, personnel may need to collect additional data when a fault is suspected) and don't require expensive cable runs. They also have the advantage that they can "look" at a machine daily rather than monthly, which is an advantage over walk around systems, particularly when a machine has a faster failure mode.



Engineering Problems... Into Solutions

FOR OVER 20 YEARS, KIPCON HAS BEEN DESIGNING AND INSPECTING COOLING TOWERS OF ALL TYPES.

YOU NEED IT... WE DESIGN IT

Kipcon Inc. provides structural designs for new cooling towers and retrofits of existing towers, whether it be a cross-flow, counter-flow, wood, concrete, fiberglass, wet and/or dry system. This includes basin design and basin load tables.

YOU HAVE IT... WE INSPECT IT

Kipcon Inc. also provides complete cooling tower inspection services and can develop remedial plans of action for retrofitted towers.

YOU WANT DRAWINGS... WE WILL DRAFT THEM

Kipcon prepares drawing packages, including erection plans, connection and fabrication details.

Kipcon Inc.

www.kipcon.com
marketing@kipcon.com
(800)828-4118



Engineers/Inspectors

Call us today to discuss your cooling tower needs.



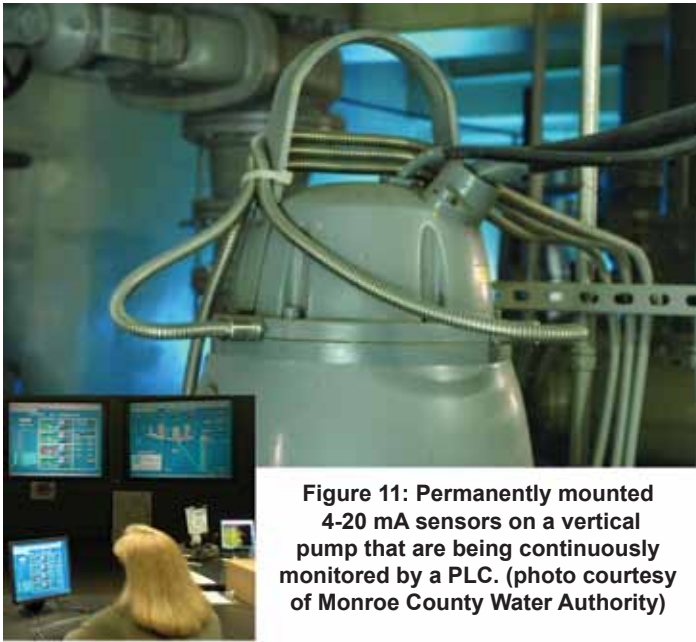

Figure 11: Permanently mounted 4-20 mA sensors on a vertical pump that are being continuously monitored by a PLC. (photo courtesy of Monroe County Water Authority)



Figure 12: Ranger®, 9420, and Echo® are examples of wireless sensors and wireless monitoring systems

Monitoring Software: Monitoring software is the heart of a predictive maintenance system. It contains a database that houses the machinery, alarm, and route information; all data collected; and includes all of the tools needed to enter, analyze, and report data. The software has modules to enter a machine database, create routes, download and unload route data, run reports, and analyze data. It also will have some way of showing the overall status of machines being monitored as in Figure 13, which shows there are only 4 points of all those being monitored that are tripping a critical (red) alarms. Note: This particular database is monitoring about 200 points. The Smart Alarm Panel display brings the problem points to the top of the list. How can anyone argue with the value of such information, the status of the machinery in your plant at-a-glance?

Skill Required for PdM Program

There is no question of the value of a well-run predictive maintenance program and anyone can easily purchase a good quality system capable of achieving one. However, if a system is purchased, what is required of the individuals to start and run a program? And, what sort of results can be expected?

Beginner Skill Required: Routine data collection requires an Introductory Level of skill and can be learned quickly. It is recommended that a person involved in data collection take an introductory level vibration analysis class, like the Vibration Institute's, Introduction to Machinery Vibration (IMV) class. Validation of

understanding can be achieved by taking the Category I Certification Examination and being certified as a Vibration Analyst by a Certifying Body in accordance with ISO/IEC 18436-2:2014, Condition monitoring and diagnostics of machines – Requirements for qualification and assessment of personnel – Part 2: Vibration Condition monitoring and diagnostics. In order to sit for the Category I exam, the Standard requires that the candidate have a minimum of 30 hours of appropriate training and 6 months of experience. Figure 14 shows a typical slide from an introductory course indicating the proper locations to mount accelerometers for data collection.



Figure 13: Alarm panel from the Echo® software showing status of machines

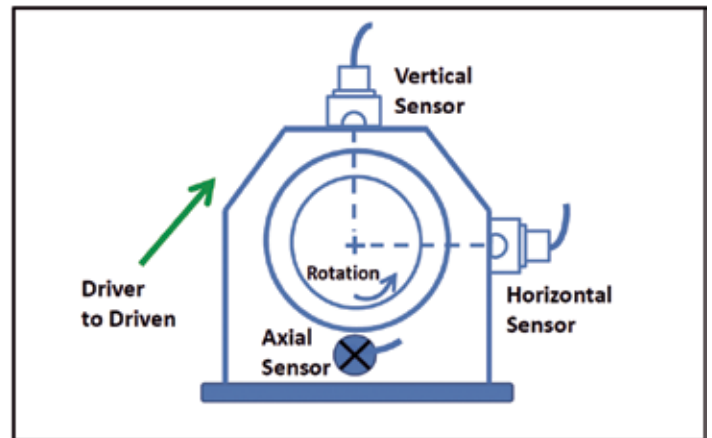
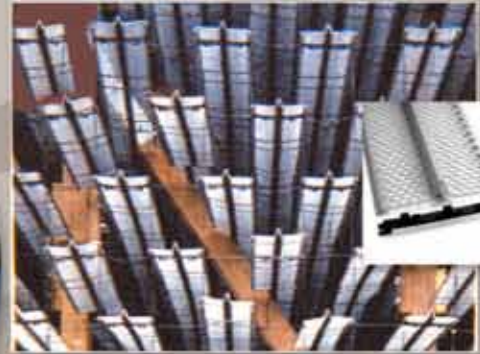

Figure 14: Diagram showing the proper locations to mount sensors for vibration monitoring [6]

An introductory level is simply a stepping stone. You cannot expect to run a successful ongoing program if your analyst only has introductory level training and a Category I certification. They must continue their training to achieve a minimum of a basic level of skill.

Alarms & Trending: Most vibration systems come with trending and fault analysis software that automatically looks at overall data versus alarm levels when unloaded from a data collector. Reasonable alarm levels can be determined with a moderate effort by using recommendations found in many ISO, ANSI, API and other Standards, such as, ISO 10816-1 Mechanical vibration – Evaluation of machine vibration by measurements on non-rotating parts, ISO 7919 Mechanical vibration of non-reciprocating machines – Measurements on rotating shafts and evaluation criteria, and API 670 Machinery Protection Systems, as well as other published

It's what's inside that really matters.



C. E. Shepherd Company, L. P.
www.ceshepherd.com



Better components make better towers.

Since 1957, our primary business has been innovation!
We encourage inquiries for custom product solutions!

- PVC Coated Hanger Grids
- Stainless Steel Hanger Grids
- Gull Wing Splash Fill Slats
- V-Bar Splash Fill Slats
- Film Pack
- Drift Reduction Units
- Nozzles & Accessories

C. E. Shepherd Company, L.P.
2221 Canada Dry Street
Houston, TX 77023
Telephone: 713.924.4300
Fax: 713.928.2324
www.ceshepherd.com
sales@ceshepherd.com

Whether your project requires new construction or retrofit, standard products or custom solutions, Shepherd Tower Components are a perfect fit.

resources such as the Blake Chart, Figure 15, or a simple R/C (p-p displacement / diametrical bearing clearance) for fluid film bearings, Figure 16.

Other good ways of setting reasonable alarm levels are consulting with a Certified Vibration Consultant or getting involved with one or more Professional Organizations such as the Vibration Institute, <http://www.vi-institute.org/>, the Canadian Machinery Vibration Association, <http://cmva.com/>, or a more specialized organization like the Cooling Technology Institute, <http://www.cti.org/>.

Coupling data collection with good alarm levels should provide a warning when a machine is developing a fault. Viewing trend plots will add insight as to how fast the machine is deteriorating and how soon corrective action needs to be taken. All this can be accomplished with a moderate effort and a little determination.

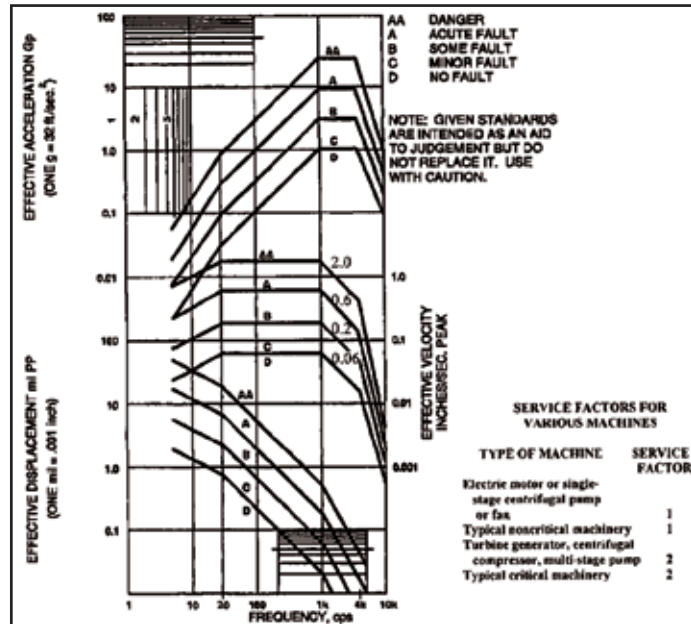

Figure 15: The Blake Chart has been shown to be a good reference for machine condition in the absence of other specific historical data. [6]

Maintenance	Allowable R/C	
	3,600 RPM	10,000 RPM
Normal	0.3	0.2
Surveillance	0.3-0.5	0.2-0.4
Shut down at next convenient time	0.5	0.4
Shut down immediately	0.7	0.6

Figure 16: Allowable R/C for evaluation of fluid film bearings [6]

Basic Skill Required: Determining what points should be monitored, what measurements should be made, what alarm levels to set, and perform basic trending and spectrum analysis requires a Basic Level of skill as a vibration analyst. It is recommended that in addition to an introductory level class, a basic level class like the Vibration Institute's Basic Machinery Vibration (BMV) class be taken. Validation at this level can be achieved by taking the Category II Certification Examination. In order to sit for the Category II exam, the Standard requires that the candidate have a minimum of 38 additional hours of appropriate formal training and a total of at least 18 months of experience. Note: Many, if not most, successful predictive maintenance programs are run by Category II Certified Vibration Analysts.

Fault Analysis: This is where the bar starts to raise. Once an alarm is triggered and it is seen in the trend plot that the condition is getting worse, Figure 17, a skilled vibration analyst must now look at the data, including; time waveform, spectra, High Frequency Energy (HFE), and demodulated data, such as Spike Energy™ or PeakVue™ to determine what the fault is. This action requires a trained vibration analyst to get an accurate diagnosis of the particular fault. In the plot below, the overall peak velocity has triggered a warning (ALERT) alarm so there is still some time to do diagnostic analysis and schedule a repair before the critical (FAULT) alarm is reached.

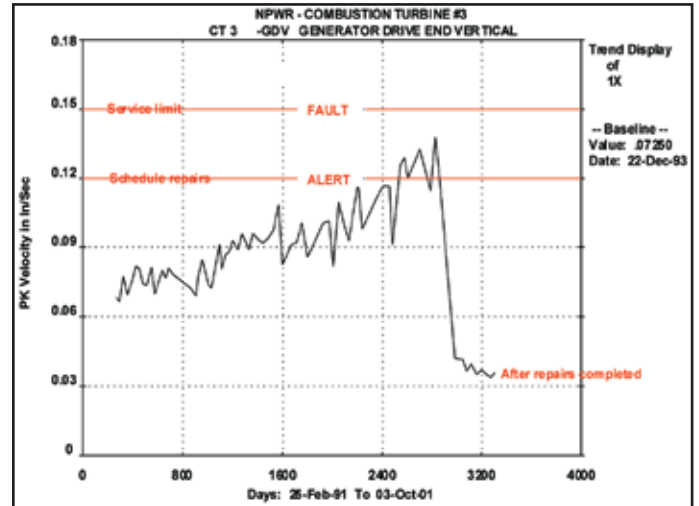

Figure 17: Trend plot on a turbine tripping a warning alarm.

As in most fields of study, the more training and experience a person has, the better they are. As the following equation shows, skill is developed with a combination of training and experience; the more you have of both, the better you get. People make the mistake of thinking that they will become more and more skilled through experience only. While this is partially true, they never will actually get to the next level without more formal training as well.

Vibration Analyst Equation:

$$\text{Training} + \text{Experience} = \text{Skilled Vibration Analyst}$$

To the untrained eye, the time waveform and spectrum plots in Figures 18 and 19 are basically meaningless. However, to a trained certified vibration analysis, they provide data that can be analyzed and the fault determined.

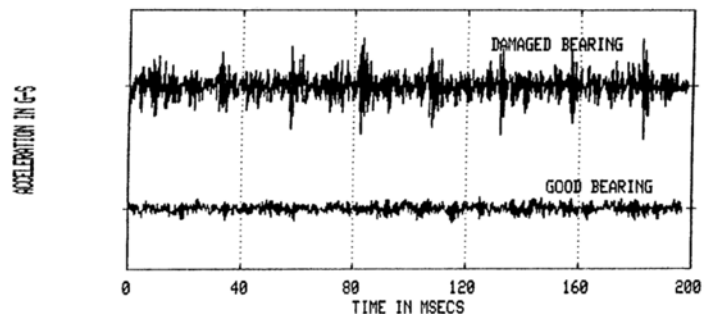

Figure 18: Time waveforms of both good (bottom plot) and bad (top plot) rolling element bearings

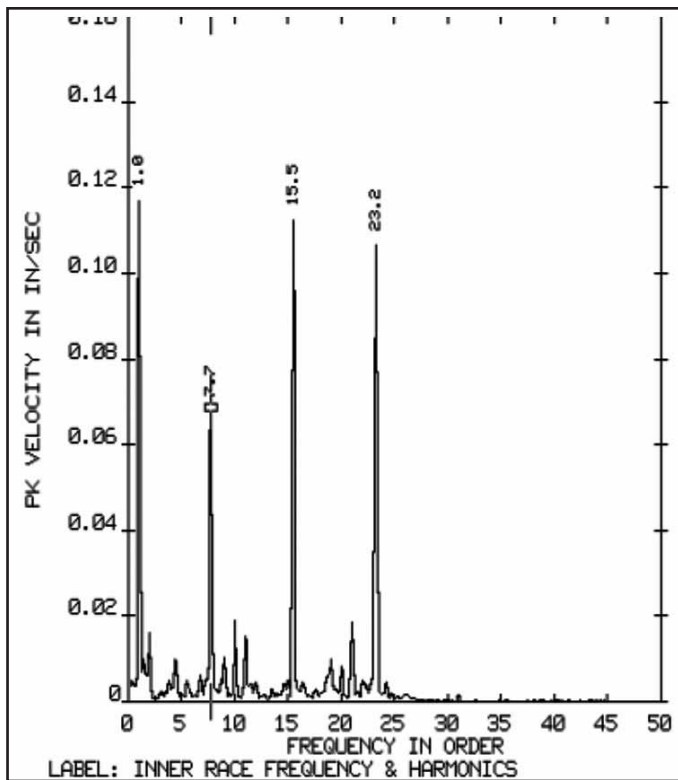

Figure 19: Spectrum plot showing a rolling element bearing with an inner race (BPF) defect

A Category II Vibration Analyst can certainly do basic fault analysis, particularly for common, easier diagnosed faults such as unbalance, looseness, misalignment, and some rolling element bearing faults such as show above. However, as things get more complex, Figures 20 and 21, additional training beyond the basic level classes is recommended. Additionally, an analyst may want to study some corrective technologies such as dynamic balancing and shaft alignment to be able to fix two of the most common problems found in machinery.

The example below is a more complicated diagnostic problem than those above. Early detection of this problem was reported by the use of a High Frequency Detection (HFD) technique, PeakVue™. Since the analyst understood advanced diagnostics, he could recognize there was a developing fault and then analyze it using the velocity trend and spectrum plots, Figure 21. It can be seen that the trend increased quickly in the last couple of months when the gearbox was not being monitored but was caught just in time to save the gearbox from catastrophic failure. This makes a strong case for monitoring equipment on a regular basis and not skipping a scheduled data collection because someone is too busy. This happens all the time

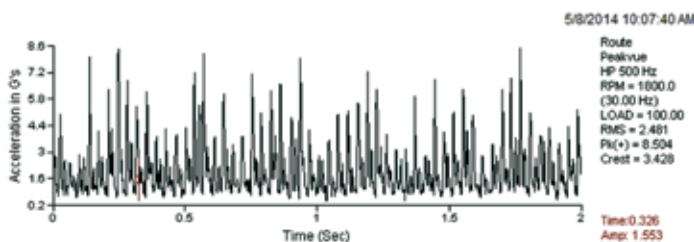

Figure 20: Demodulated time waveform on a gearbox indicates a problem

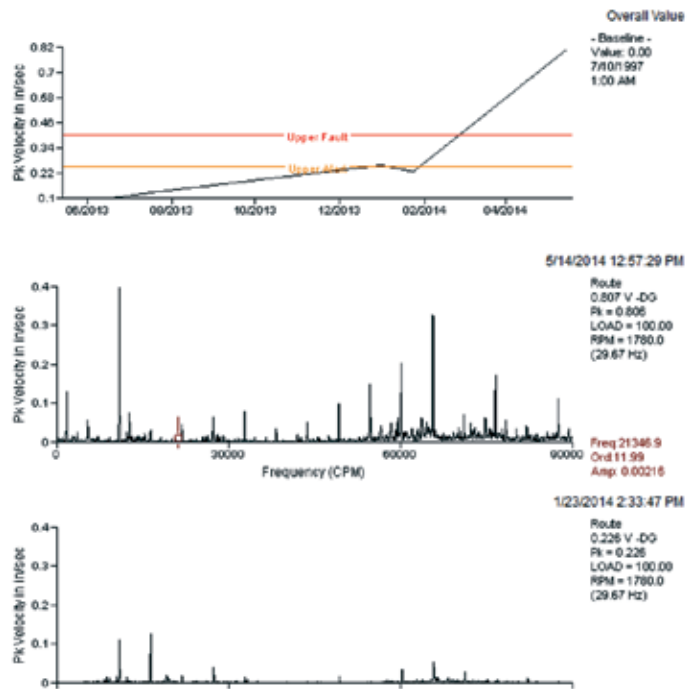

Figure 21: Trend plot and two spectra showing the progression of the fault

Intermediate Skill Required: If a person has responsibility for a Predictive Maintenance program, needs to direct the efforts of others, or simply wants to be better at detection and diagnosis of faults, an Intermediate Level of skill is recommended. Recommended classes include an intermediate level vibration class such as the Vibration Institute’s Machinery Vibration Analysis (MVA) class plus a dynamic balancing class such as the Vibration Institute’s Balancing of Rotating Machinery (BRM) class. An analyst may also want to consider purchasing a shaft alignment system and take a Basic Shaft Alignment class. Validation at this level can be achieved by taking the Category III Certification Examination. In order to sit for the Category III exam, the Standard requires that the candidate have a valid Category II certification, a minimum of 38 additional hours of appropriate training (although more is recommended) and a total of at least 36 months of experience. While a shaft alignment is not required for the vibration certification, it is highly recommended if your plant has a lot of shaft alignment issues, which are very common whether you know it or not. If you have pumps, you can bet you have alignment problems.

Prognostics (Condition/Severity Assessment) or Predicting the Future: Maintenance supervisors and plant manager don’t really care if the problem is a crack in the outer race of a bearing, misaligned shafts, looseness in the foundation or a seal rub. What they want is information. Can I run the machine? How long can I run the machine? When will the machine fail or be unable to perform its intended function? This is prognostics and is difficult at best to do well. The time between the detection of a fault and either failure or significant performance degradation is difficult to predict and requires the knowledge of a Skilled Vibration Analyst.

As shown in the condition monitoring equation below, it takes good data and a skilled vibration analyst to provide useful information. And it turns out, the more training and experience an analyst has, the more skilled they become, particularly at prognostics.

Condition Monitoring Equation:

Good Data + Skilled Vibration Analyst = Useful Information

Another way of looking at it is that instruments can collect data but skilled people analyze, diagnose, and do prognostics of faults. Even the best analysts can't make any guarantees when it comes to prognostics. However, the more training and experience they have, the more likely they will be close.

Useful information is the desired outcome of a Predictive Maintenance Program for the purpose of effective Asset Management. This requires on going professional development for the analyst and the accumulation of diagnostic experience. The more training and experience the analyst has, the better the information that can be provided for critical asset management decisions and optimized production.

The Trap: Beware, there is a trap! What if the information provided by the Skilled Vibration Analyst is not entirely accurate? What if the production manager decides to ignore the recommendation of the analyst and lets the machine continue to run and it doesn't fail or stop performing its intended function? What if the Skilled Vibration Analyst says to continue to run and the machine fails? Is it time to abandon the program, this author says no! No one, no process, and nothing is perfect; we just don't get everything right all the time. Use these seemingly "failure" situations as opportunities to hone your alarms and program effectiveness, not cancel them. If a machine does fail, you have incredibly valuable information in your database; you now know where the machine will most likely fail the next time. Simply reset your alarms and the next time you are likely to be spot-on in your prognosis. Remember the turbine? How much risk are you willing to take?

Advanced Skill Required: Advanced diagnostics and good prognostic analysis require an Advanced Level of skills and experience. It requires training in advanced topics such as rotor dynamics, transient and forced vibration, modal analysis, and advanced signal processing. In order to achieve a Category IV Vibration Analyst certification, the Vibration Institute recommends three classes Advanced Vibration Control (AVC), Rotor Dynamics and Modeling (RDM), and Advanced Vibration Analysis (AVA) a tall order by anyone's standards. Validation at this level can be achieved by taking the Category IV Certification Examination, a very difficult exam. In order to sit for the Category IV exam, the Standard requires that the candidate have a valid Category III certification, a minimum of 64 additional hours of appropriate training and a total of at least 60 months of experience. Frankly, this level of certification is not easy to achieve and is left to the most serious analysts to pursue. The more training and experience the analyst has, the better are their chances of making accurate assessments. Few analysts make it to this level as it requires a huge commitment to professional development and a minimum of 5-years of experience.

Root Cause Analysis and Life Extension – Even if an analyst becomes very good at all of the above functions, including prognostics, it would be better if the root cause of a chronic problem were determined and modifications made to the machine to extend its service life. This is generally only done if there is a chronic problem and a short life cycle for a critical machine. Often, this type of action requires the assistance of an experienced vibration consultant and possibly the manufacturer or aftermarket service

organization. It generally requires an in depth understanding of advanced vibration analysis techniques, machinery, machinery components, and maintenance procedures for this type of analysis and machinery modification.

This may be a job left for the experts or the best in the business. While a good analyst can take a shot at this, it may be a good time to call in a seasoned certified vibration consultant that specializes in the type of machinery with the problem. Certified Vibration Consultants that are certified by the Vibration Institute are listed on the Vibration Institute website at <http://www.vi-institute.org/certifiedconsultants> by Category for easy reference.

Financial Documentation and Records – In order to get management support for funding equipment, training, and other professional development, maintenance must show a reasonable ROI (Return on Investment). Since the people directly involved in these programs are usually technical, they may not know how to determine ROI and generally do not do a good job of documenting costs and savings. So while the actual ROI may be huge, management doesn't know it and thus doesn't provide ongoing funding, especially for training and professional development. This can and often does spell disaster for a predictive maintenance program.

Another way to provide justification to management is to provide them with overall machine status, availability and other statistics. An example of this type of plot is that is possible is shown in the "Machine Status Report" in Figure 22. How many plants can state the current status of all of the current critical machinery as shown in the Machine Status Report below? At a glance, the overall status of the plant is known; how can anyone argue with the value of such information? But, someone needs to be dedicated to the program.

Another way of watching the effectiveness or thoroughness of a Predictive Maintenance Program is to track machine Monitoring Statistics, Figure 23. This report shows that equipment is being monitored and more importantly, that the machines are in good condition and under control, as is evident with the lack of Priority 1 problems. How many plants can report the same?

The Training Paradox - More often than not, the employees involved in driving and working vibration analysis programs are skilled trades and millwrights, not engineers. Because of this, management is often reluctant to send them to off-site training classes or technical conferences. This results in a confusing paradox to this author. Management wants these same skilled trades people to make extremely important decisions on machine availability that affect production and profits, which they do based on their skill set as a vibration analyst. Then, more often than not, management doesn't feel it's in the company's best interest to invest in their professional development. They seem to have less of a problem sending engineers and other professional people to training and conferences but not the trades' people. Without ongoing professional development and formal training, those involved in vibration analysis cannot expect to achieve a high level of performance.

Program Cost and Budgeting – The cost of a good portable vibration monitoring system, including data collector, sensor, and software, can start as low as \$20,000 and go up to \$50,000 or more depending on the features desired. Often, the system vendor will include some basic startup training in the system cost but even if it is not included, it is offered as an option. If you buy a system,



Industrial Fabrication & Supplies

One Call Does It All!

Full Service Fabrication & Supply
Quick Response + On-Time Delivery

"Exceeding our customer's expectations for over 35 years"



FRP Grating & Shapes



Fabrication & Assembly



Fiberglass Casing



Hardware & All Thread



Decking & Platforms



Access Ladders

Our customers benefit with significant labor cost savings and improved safety when fabrication and assembly are done at our shops

2 Locations:

West Coast & Gulf Coast
800-245-8158
www.cooltower.com



Member

WEST COAST
LUMBER
INSPECTION
BUREAU



"Our FRP and forest products are proudly made & fabricated in the USA"

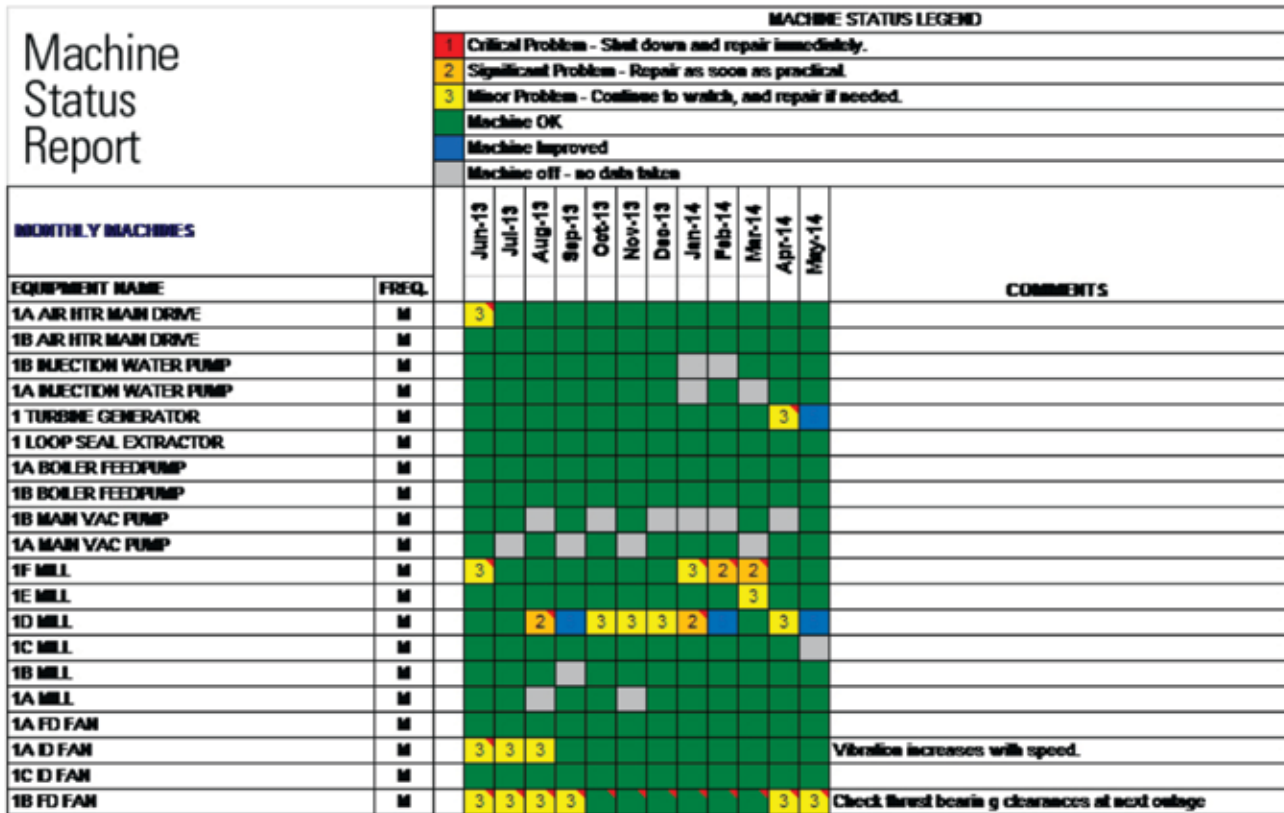

Figure 22: Machine Status Report showing machine fault status.

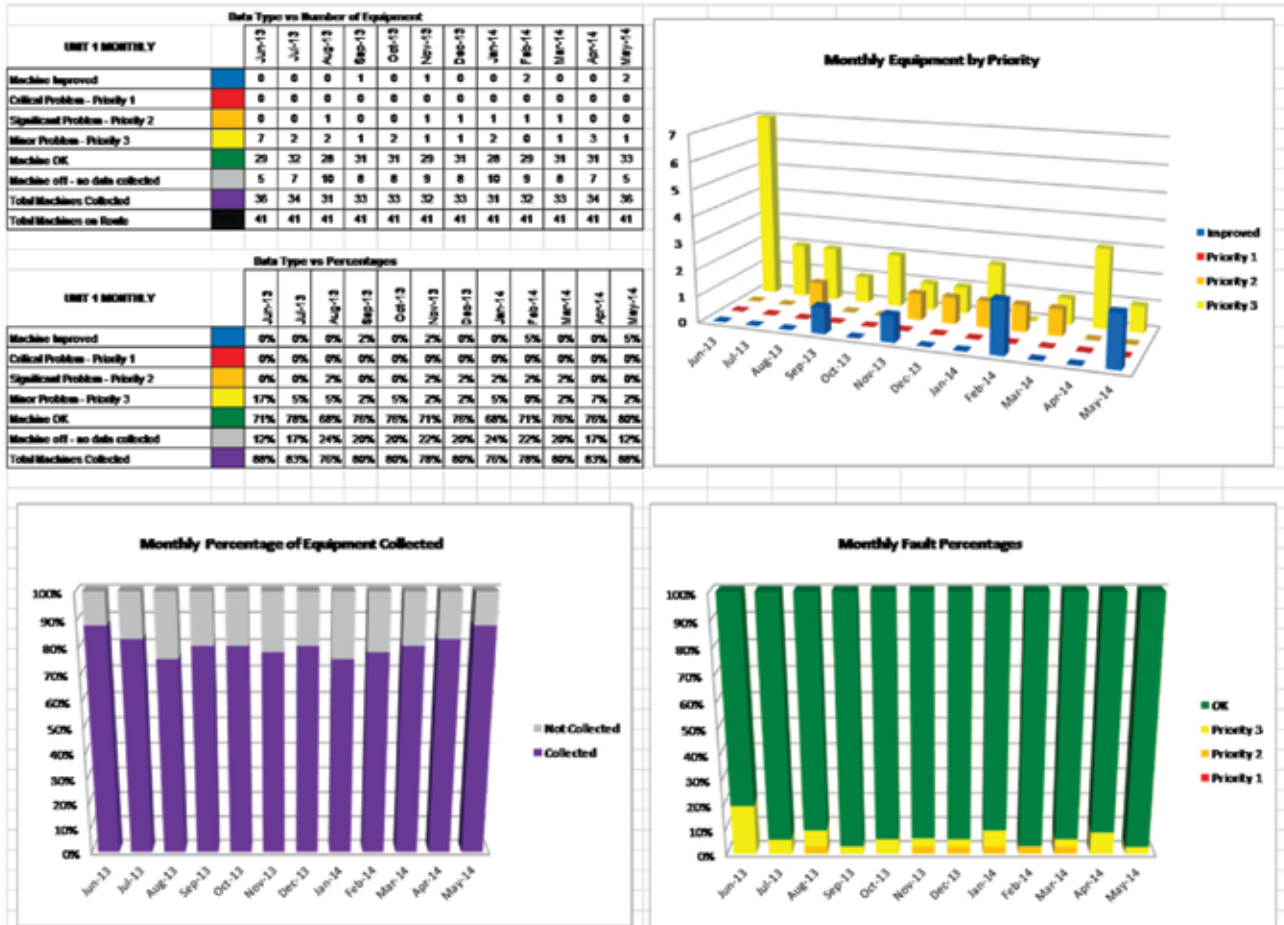

Figure 23: Monitoring Statistics Report

include the startup and system training; it is well worth the investment. How often have you thought, if I could only sit in on a day or two training on some software program you were using, how much more effective I could be. The same is true here. Predictive maintenance software packages have tremendous capabilities, if and only if, you know how to use them.

Don't mistake the vendor's startup training as vibration training. While vendors do offer vibration training, their startup training is generally focused on the setup and use of the system you purchased. Be sure to budget for a vibration analysis class to be taken about 6 months, for a beginner, after setting up your system and having an opportunity to collect some data. Then, budget for ongoing training and/or professional development each year.

Introductory or Basic machinery vibration training, including certification testing costs about \$2000 plus travel and requires a full week commitment by the individual. Don't be part of the Paradox mentioned above; invest the time and funds to get started the right way. Further training is recommended at various intervals; typically at least once per year. Other than a person's time, it is relatively inexpensive to get started when compared to the probable cost savings. I'll say it again, budget for both the startup and ongoing training and professional development, it will pay off in the long run.

Inventory Savings – When a developing fault is identified, there is generally time to order parts for the repair. Thus, in some cases, companies can have less costly inventory in stock that is tying up money and possibly costing more at the end of the year in taxes. This should, however, be considered carefully for highly critical machinery.

Increased Damage Due to Failure - The cost to replace a bearing, time and materials, may be minimal if the right parts and people are available for the repair. However, if the machine fails catastrophically which causes additional damage to the shaft and other machine components, then the parts needed and the time required can increase significantly costing more to repair the machine and losing more production time.

Lost Production – Some processes run 24/7 and companies can sell 100% of the product that they make. In cases like this, when a machine is down, the lost sales cannot be recuperated. This can be and often is the largest part of the financial loss model. When a process is down unexpectedly for several days due to an unexpected failure, production losses can be in the hundreds of thousands to millions of dollars. How does that compare to the cost of a system?

Reduced Insurance Costs – Some insurance companies will charge lower rates on equipment breakdown insurance if a company can show they have a predictive maintenance program that reduces risk and some even offer services to help mitigate the risk. CNA insurance company says in their brochure, "We recognize that the least disruptive loss is one that never occurs". To control risk, they offer services in predictive and preventive maintenance and other risk control services. [7] Zurich says in their online brochure they provide site risk assessment including predictive maintenance. [8] Thus, it is obvious that the insurance companies that provide the coverage believe in predictive and preventive maintenance.

How to get started – Getting started is a bit of a Catch 22 situation. You can't get started because you probably don't have much

knowledge of Predictive Maintenance, even less of vibration analysis, and most likely no experience at all. And, it is recommended that someone have a Category II certification before setting up a machine database and routes. And by the way, it takes a minimum of two classes and 18 months of experience to get the certification. You can't start a vibration program because you don't have the experience and you can't get the experience because you don't have a vibration program, catch 22. So, where do you start?

First, does it make financial sense? Assemble the appropriate people and have the following discussions. Determine what machines are critical to your operation and what machines have chronic problems. Determine also what other machinery, even if reliable, supports a critical operation and could cause a slowdown or stop production if it failed. Determine as accurately as possible what it has cost in the past when these machines went down unexpectedly and what it would cost if they failed now. That should provide a financial baseline for what it is worth to your company to invest in condition monitoring.

Just start! Short of hiring a Certified Vibration Consultant to startup a program, which probably isn't a bad investment, Just Start? Buy a system from one of the many reputable vendors in this business. You can hardly go wrong with any of the systems available today. Vendors are anxious to get new business, so get them to help you install the system and get it up and running.

You need training. If you can't get the vendor to do the installation at no charge, pay to have them help you and take their startup class on system operation. Many programs fail right off the bat because companies don't want to pay for startup help. Don't let this be you. You need it so, as Nike says, Just Do It! If you really want to jump start the program, bring in a consultant for a few days or periodically on a contract basis over the course of 6-months to a year to help you set up some routes, establish alarms, and get started in data collection. If you start on your own, start small. Set up a few machines, collect data on them, and start establishing some trends. Don't try to setup the whole plant up front, it won't work.

Take advantage of similar machines. If you have several of the same machines, collect data on them all and compare the readings. I once did a demonstration in a plant where they had 6 of the exact same compressors. We took data on all six units and one had much higher vibration than the others. The customer called the compressor manufacturer, told them of our results, and was told by the vendor to shut down the machine immediately! Take advantage of having similar machines.

Seek out advice. If you feel like you don't have a clue, go to a local Vibration Institute or CMVA Chapter meeting, conference, seminar, or similar event and talk to the analysts there. You will find that they are happy to help other people. Networking is a great benefit of professional organizations and is sorely overlooked. After you have dabbled in it for 6 months, take an introductory class and if you're bold enough, take the Category I certification exam. Now you can start building your program.

Don't be afraid to make a call. If vibration doubles something is wrong and the machine should be evaluated. Tell someone and if it is a critical piece of equipment, this may be a good time to spend a few extra dollars and bring in a certified vibration consultant. It will serve two purposes. First, you will find out the status of the machine and, second, it will be a great learning experience for you.



Conclusion – Affordable tools are available to conduct effective Predictive Maintenance programs in most plants. A consistently run Predictive Maintenance program can identify faults and save significant amounts of money for companies, but it takes three ingredients to succeed; desire by an individual, support by a company, and commitment to succeed.

Trademarks

Spike Energy is a trademark of Rockwell Automation
PeakVue is a trademark of Emerson Process Management
Ranger is a registered trademark of Bently Nevada, Inc.
Echo is a registered trademark of PCB Group, Inc.

Bibliography

1. I-35W Mississippi River bridge. Wikipedia. http://en.wikipedia.org/wiki/I-35W_Mississippi_River_bridge. 1/13/2015.
2. Minnesota Bridge Collapse 2013. Bing Images. <http://www.bing.com/images/search?q=Minnesota+Bridge+Collapse+2013&FORM=RESTAB#view=detail&id=6432D2CF2D1AF28A9CC22C298DD4A46AF12152C4&selectedIndex=0>. 1/13/2015.
3. 2009 Sayano – Shushenskaya power station accident. Wikipedia. http://en.wikipedia.org/wiki/2009_Sayano-Shushenskaya_power_station_accident. 1/13/2015.
4. Sayano-Shushenskaya Accident. Bing Images. <http://www.bing.com/images/search?q=Sayano-Shushenskaya+Accident&FORM=RESTAB#view=detail&id=055F7E1446D0BF8B00C713B56F385DB7C84E02B3&selectedIndex=0>. 1/13/2015.
5. Sayano-Shushenskaya Accident. Bing Images. <http://www.bing.com/images/search?q=Sayano-Shushenskaya+Accident&FORM=RESTAB#view=detail&id=055F7E1446D0BF8B00C7328E5DA0DA321127A0A7&selectedIndex=11>. 1/13/2015.
6. Eshleman, Ronald L., Ph.D., P.E. Basic Machinery Vibrations. Clarendon Hills, IL. VI Press, 1999.
7. Equipment Breakdown Brochure. CNA. 2009. https://www.cna.com/web/wcm/connect/320b1d19-db-db-4f09-9a01-4d6792564eac/PropKitEquipBrkdn_CNA.pdf?MOD=AJPERES. 1/13/2015.
8. 2012 Risk Engineering products and services overview. Zurich. 2011. http://www.zurichna.com/internet/zna/sitecollectiondocuments/en/products/riskengineering/11-2460_re_products_services_overview.pdf. 1/13/2015.



setting standards -
over 20 years ago

- full range of fills + eliminators in PVC + PP
- worldwide references (natural draft + forced ventilated)
- inhouse production of tools and machines (no glue!)
- online calculation tool of different fills



Trickle Fills
vertical + crossflow design



DE125 (< 0.0005%)



PP + PVC

Your tower represents a **HUGE** investment...

*Isn't it worth investing a small amount to keep it "in the Pink"
by preservative spraying the wood structure?*

PREVENTION IS ALWAYS THE RIGHT SOLUTION!!!



Decay Prevention & Slime Control with PROVEN RESULTS
Nationwide Since 1964



Internal Pocket Rot



Plenum Slime Growth



Also Featuring:

- Fill Cleaning •
- Fan Deck UV Protective Coating •
- Dry Mothballing •
- Wood Analysis •
- Structural Inspections •
- Spray-In Basin Linings •



Spray Technician applying red dye colored preservative.

COOLING TOWER SOLUTIONS
by Spraying Services, Inc.

Phone: 713.941.1944 • Fax: 713.941.2545

www.spraying-services.com



An Alternative Approach To Disinfection Using Chlorine Dioxide

Ingmar Hermans and Vincent van Camp
TwinOxide International B.V.

Abstract

The use of oxidizing biocides is among the most cost effective means of disinfecting water. Chlorine dioxide has various benefits compared to other oxidizing biocides, but its stability, properties and characteristics necessitate “in situ” generation, typically using precursor solutions, in a Chlorine Dioxide Generator is a common practice. Apart from chlorine dioxide gas or vapor, the precursor solutions can pose a potential health and safety hazard and require appropriate safety precautions to be incorporated in the design and operation of generation and dosing equipment. The use of solid precursors can simplify the process of generating of chlorine dioxide, eliminate some of the potential hazards encountered with other generation methods, and produce stable chlorine dioxide solutions which can be used in many types of disinfection applications. Attributes of chlorine dioxide, its generation and applications are discussed in this paper.

Introduction

Chlorine dioxide is not new in the realm of disinfectants. However, there are various methods to bring chlorine dioxide to better fit end-user’s functional requirements, safety of handling and application. Cooling water treatment is one of the fields of application that has very specific end-user requirements as to viability and of disinfecting agents related to safety, practicality, efficacy and economics. The main differences revolve around precursors, which may utilize liquid, gaseous or solid state chemicals, or “stabilized chlorine dioxide solutions”.

Cooling Water Treatment Requirements

Cooling of a process or products of a process using water results in an increase in the temperature of the water used for the cooling process. The increase in temperature would typically increase the corrosion and scaling potential within the cooling water. If the cooling water system utilizes evaporation for dissipation of the heat picked up by the cooling water then in addition to an increase in temperature, a concentration of dissolved solids builds up in the water, these solids entering the system as components or contaminants in the water used to make up or maintain the water volume in the system. The increase in concentration of dissolved solids in the cooling water will further increase the potential for scale formation and corrosion. The evaporation of water within the cooling system would typically be accomplished by exchanging heat with the air. The cooling tower not only functions to cool the water but also acts as an air scrubber. Therefore additional contaminants are introduced into the cooling water from the air. These would typically be particulate matter and microbiological material. Therefore evaporative cooling systems need to be designed, operated and/or treated to control corrosion, scaling, fouling and microbial activity within the cooling system, in order to minimize damage to equipment through corrosion and loss of



Ingmar Hermans

heat transfer or performance due to scaling or fouling. This evolves into the use of treatment chemicals whose functionalities are corrosion inhibition, scale inhibition, dispersion, surfactant and biocide/disinfectant. Although all of the concerns are of vital importance with respect to protection of the plant and performance, the microbiology of the system can cause fouling of heat exchangers and tower packing (Biofilm), and subsequent loss of heat transfer efficiency, corrosion within heat exchangers, pumps and distribution pipework (Microbiologically Induced Corrosion - MIC) may also be a Health and Safety concern (pathogens such as Legionella pneumophila - Legionnaires Disease).

Cooling water or cooling systems offer a somewhat ideal environment for the support and proliferation of microbial populations. Typically nutrients are present in significant concentrations, pH of the water is typically between 7 and 9, and the water is warm but typically below 60oC (140°F) and suitable for microbiological growth. In some cases process leaks or contamination can provide additional organic nutrient material which can dramatically increase the rate of growth of microbial species. Operation of certain systems can lead to stagnant water in the cooling system or create dead-legs which promote localized growth of microbial species and biofilm formation, which can create a rapid contamination of the entire cooling system when this stagnant water or dead-legs are brought back into the system’s cooling water recirculation.

Control Of Microbiology In A Cooling System

Biocides or disinfectants are used to control microbial populations and biofilm formation within a cooling system. The biocide treatment may be based on an oxidizing biocide, a non-oxidizing biocide or a combination of both. Each of these approaches has its own virtues, but in many, if not most, cases an oxidizing biocide based program is the most effective in terms of efficacy, as defined by speed of kill, is broad spectrum, as defined by efficacy against different types of organism, and economics. Intermittent use of non-oxidizing biocide(s) to supplement and enhance a baseline oxidizing biocide program may be regarded as best practice.

Typical oxidizing biocides used to treat cooling water are chlorine, bromine, and chlorine dioxide. Hydrogen peroxide, ozone and peracetic acid are also effective but less commonly used. Again each has its own inherent advantages and disadvantages.

Much of the concerns with regard to oxidizing biocides are related to safely in storage handling and application. Because of the nature of some of the oxidizing biocides or their precursors, a potential fire hazard may be created by spillage and/or decomposition. Some require generators or special dosing equipment. These concerns and issues have to be addressed and facilities specifically designed and constructed to ensure safety. This can add significant cost to what initially appears to be a “cheap approach”. Oxidizing biocides used for microbiological control in evaporative cooling systems are given in Table 1.

Giving you the ACTvantage you deserve!

ACF Series Induced Draft Counter Flow

- 86 single cell models ranging from 97 to 1043 nominal tons
- Over 250 multiple cell configurations
- CTI STD-201 certified
- ASHRAE 90.1 compliant
- Ideal for both new and replacement projects
- Flexible arrangements and configurations
- Wide range of options and accessories
- G-235 Galvanized steel construction
- Stainless steel 304, 316, or 316L options
- 5 Year mechanical / 1 year total product warranty
- Extended parts & labor warranties available



ACX Series Induced Draft Cross Flow

- 69 single cell models ranging from 102 to 1074 nominal tons
- Multiple cell configurations for any project size
- CTI STD-201 certified
- ASHRAE 90.1 compliant
- Integral drift eliminators and inlet louvers
- Wide range of options and accessories
- G-235 Galvanized construction
- Stainless steel 304, 316, 316L options
- 5 Year mechanical / 1 year total product warranty
- Extended parts & labor warranties available



Halogenation

The most commonly used biocides are the halogens chlorine and bromine. Sodium hypochlorite and bromide activated with sodium hypochlorite are probably the most popular approaches for halogenation programs. Sodium hypochlorite is obviously a lot easier and safer to handle than chlorine gas, but it does have the disadvantage that it decomposes with time, losing its active chlorine strength. Therefore fresh supplies are desirable or progressive increased volumes are required to obtain the target free halogen concentration.

The main biocidal compound in these approaches is hypochlorous acid or hypobromous acid,

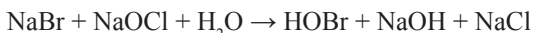
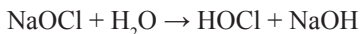

However, in water the hypohalous acid, HOX, undergoes a reversible reaction, being in equilibrium with its corresponding hypohalite anion.

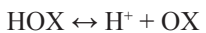

This reaction moves to the right with increasing pH, the pKa values being in the order of 7.5 for chlorine and 8.6 for bromine. Relative proportion of the acid and anion are shown in Figure 1.

By reaction with organic matter or organic compounds present in the water, chlorine and bromine can form Trihalomethanes (THM) which are environmental pollutants and many are suspected to be carcinogenic(1). They can also form Adsorbable Organic Halides (AOX) which is also regarded as environmental pollutants and is some Water Authorities stipulate a maximum AOX concentration in plant effluent consents. In a programs utilizing halogenation, particularly chlorine, other chemical components commonly applied in treatment programs may be susceptible to degradation or decomposition through reaction with the halogen. Alternative halogen resistant treatment chemicals are available but these may be more expensive than the traditional chemicals. These issues tend to make halogenation, particularly chlorination, becoming less favorable in certain countries. Although chlorine dioxide contains a halogen, its properties and mode of action is entirely different to halogenation, basically the chlorine dioxide free radical (Figure 2) as opposed to a hypohalous acid. As an alternative to halogenation chlorine dioxide is a viable approach since it does not produce THMs or AOX and has several other benefits compared to halogenation.

Chlorine Dioxide

Chlorine dioxide is an unstable gas and is typically generated at point of use and applied as an aqueous solution of the gas. It is applicable over a wide range of water pH between 4 and 11(2). Studies have shown that microbial disinfection with chlorine dioxide is as effective or superior to disinfection with free chlorine, particularly in regard to inactivation of viruses(3)(4). Relative efficacy of chlorine dioxide and chlorine(5) is illustrated in Figure 3.

Brief history of chlorine dioxide

The discovery of chlorine dioxide is accredited to the British chemist Sir Humphrey Davy in 1811, using sulfuric acid (H_2SO_4) to synthesize chlorine dioxide from the acidification of potassium chlorate (KClO_3). Over the passage of time, the original sulfuric acid (H_2SO_4) was replaced by hydrochloric acid (HCl), and potassium chlorate (KClO_3) was replaced by sodium chlorate (NaClO_3) for large-scale production(6).



The ability of chlorine dioxide to control phenol related tastes and odor by oxidizing causal compounds led to its first use in treating drinking water in the United States in the 1940s, when it was utilized in treatment plants along the Niagara River in New York State(7). The success of this application quickly led civic leaders and scientists to rely on it for resolving related odor problems in other municipal potable water treatment facilities(8)(9)(10). However, despite its proven value in this area of application, during the 1960s-70s, chlorine dioxide was increasingly abandoned because of a variety of problems related to its implementation. Some of the reasons for this abandonment were equipment and installation design problems, and the increasing cost of chemicals related to its use. Other factors involved the destructive damage to facilities due to the corrosive nature of the precursor, the poor chlorine dioxide yield obtained with the earlier generation methods and inadequate control of dosing(7).

Despite a series of setbacks over two decades, in the 1980s chlorine dioxide again captured the interest in the potential of again using it to treat drinking water. Currently in Northern America, chlorine dioxide is used continuously in as many as 500 water utilities and on an intermittent or seasonal basis in up to 900 plants(11).

Methods of Generating Chlorine Dioxide

There are several basic ways by which chlorine dioxide can be generated. A major difference is the number of chemicals or precursors required to produce chlorine dioxide. Apart from chemicals used the main difference is the efficiency of the reaction or chlorine dioxide yield, and/or weight of chlorine dioxide that the method can practically accomplish. Using photometric or electrolytic methods only one chemical, sodium chlorite (NaClO_2) is required.

Other methods use two precursors, sodium chlorite (NaClO_2) plus chlorine gas (Cl_2)

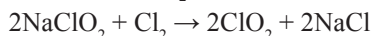

or sodium chlorite (NaClO_2) plus hydrochloric acid (HCl)



The last basic method involves three precursors, sodium chlorite (NaClO_2) plus sodium hypochlorite (NaOCl) plus hydrochloric acid (HCl)



or using sodium chlorate (NaClO_3) plus hydrogen peroxide (H_2O_2) plus sulfuric acid (H_2SO_4)

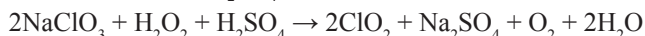

The majority of chlorine dioxide used in industry is for bleaching wood pulp within the Pulp and Paper Industry, where high yields and large production volumes are required. A three chemical method is used reducing sodium chlorate (NaClO_3) with methanol (CH_3OH) or sulfur dioxide (SO_2) and acidifying with sulfuric acid (H_2SO_4). It has been reported that the inclusion of hydrogen peroxide in this methanol based approach increases the rate of chlorine dioxide generation(12), although hydrogen peroxide can be used to “neutralize”, degrade or destroy chlorine dioxide.

Yield of Chlorine Dioxide

There are different definitions given for the “yield” of chlorine dioxide from various generation methods.

One is the “Theoretical Yield” which is the percentage of the chlorine dioxide generated compared to the theoretical chlorine dioxide which could be produced from the reaction of the precursors.

Ideally, generation of chlorine should yield the maximum amount of chlorine dioxide with the minimum amount of other residual

A Complete Power Transmission Package to Keep You Cool.



Addax Composite Couplings

Repair and Asset Management Services

Solutions for the Cooling Tower Industry

Cooling towers are one of the harshest environments for power transmission equipment. Moisture, chemicals, and minerals attack the equipment driving cooling tower fans, making durability, corrosion resistance and superior customer service a priority.

That's why customers choose **Addax® Composite Couplings** and **Falk® Renew® Prager®** repair and asset management services.

- Lower total cost of ownership — properly maintained, the cost-effective Addax Composite Coupling can last the life of the cooling tower, while its lower weight results in less wear on other system components
- Professional on-site inspection, evaluation, service and repair or replacement of gear drives, couplings and bearings
- Same-day, emergency delivery of gear drives and couplings for many applications are available to maximize your uptime

oxidant formation. In this context the yield of chlorine dioxide generation is defined by the following equation(13).

$$\text{Yield} = \frac{[\text{ClO}_2]}{[\text{ClO}_2] + [\text{ClO}_2^-] + \left(\frac{67.45}{83.45}\right) [\text{ClO}_3^-]} \times 100\%$$

Where

$[\text{ClO}_2]$ = ppm Chlorine Dioxide

$[\text{ClO}_2^-]$ = ppm Chlorite

$[\text{ClO}_3^-]$ = ppm Chlorate

$\left(\frac{67.45}{83.45}\right)$ = molecular weight ratio of ClO_2^- to ClO_3^-

Potential Hazards Associated With Chlorine Dioxide Generation

Traditionally chlorine dioxide was made with liquid precursors, which means that the entire process from initial delivery, though generation and local storage, to dispensing or dosing the chlorine dioxide product relies on fluid solutions. There are several safety concerns with respect to the nature and characteristics of the precursor, their mixture and generated chlorine dioxide solution, which many consider to be “dangerous”. The “dangers” are the potential for spillage of precursors which include strongly acidic solutions and acidic fumes, leading to potential corrosion, and, if the spilt precursors mix, premature uncontrolled generation of chlorine dioxide in an open area. There are also potential fire and explosion hazards with some precursors, their mixture and generated chlorine dioxide solution. The gas phase of the generated chlorine dioxide solution is explosive at solution concentrations above 8 grams ClO_2 per liter or 8000 ppm ClO_2 . Chlorine dioxide gas detectors and alarms should be fitted in enclosed spaces containing the generator. Bunds and even storage of precursors in separate rooms minimizes risks of spillage of precursors. Generator design and operation addresses the potential of explosion from concentrated chlorine dioxide solutions. There are two basic approaches commonly used to address this issue, the use of dilute precursor solutions or dilution of concentrated precursors en route to the generator, or, sending the concentrated precursors, unmixed, to a mixing chamber or generator situated underwater, such as submerged in a cooling tower basin, or in a water distribution line. Obviously, the many safe applications of chlorine dioxide practiced today prove that modern day design and operation of chlorine dioxide generators is a safe process.

The one area where there still is, or may be, a potential safety concern is the initial precursor solutions. Particularly in the case of the two precursor approach there is a potential for leakage in the lines carrying the precursor to the generator, but, the greater potential safety hazard is human error where the wrong precursor is fitted to the wrong section of the generation system, or the wrong precursor is dispensed into the wrong tank or container. Unfortunately there have been incidents of this nature resulting in violent and destructive explosions.

Solid Precursors

A potential route to minimize risks associated with precursors and chlorine dioxide generation would be the use of solid precursors, as opposed to a concentrated liquid or gas precursor. If one reviews the methods of generating chlorine dioxide from liquid precursors, one will soon notice that sodium chlorite and sodium chlorate can be in a solid form but many of the precursors required to “activate”

the chlorite or chlorate are only existing as a liquid or gas. In order to consider the sole use of material in a solid form one needs to initially look at the reaction of sodium chlorite with hydrochloric acid more generically.

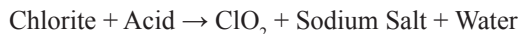

Now there is a choice of using an acid which is available in a stable solid form to “activate sodium chlorite. This could be an organic acid among which be citric acid, ascorbic acid, erythorbic acid, succinic acid, malic acid, oxalic acid or acetylsalicylic acid could be contenders. Alternatively it could be an inorganic salt that produced an acidic solution when dissolved in water, for which sodium hexametaphosphate, sodium dihydrogen phosphate or sodium bisulfate could be considered. Another approach would be to use a strong solid oxidizing agent like a persulfate ($\text{S}_2\text{O}_8^{2-}$) although this route can take a long time, up to 2 days’ to produce the chlorine dioxide. Obviously there are properties such as solubility and deliquescence which have a large or limiting influence on the choice of acid, and then efficacy or chlorine dioxide yield and costs become a consideration.

There are two basic approaches. A stabilized solid “chlorine dioxide release” tablet which is activated by dissolving in water. These are typically used for sterilizing of water for drinking when on outdoor activities such as sailing, hiking or camping where water supply of potable quality cannot be guaranteed. The other approach is the use of two powdered precursors which lends itself to the production of up to 1000 liters (264 gallons) of stable chlorine dioxide solution, which can be used as the basis of a cooling water treatment biocide program. This approach is commercially available using sodium chlorite and sodium bisulfate as separate powdered precursors.



Although the yield using these powdered precursors may be less than that obtained with liquids, smaller volumes of precursor are required since the precursor is not an aqueous solution but a solid active component. Therefore, transportation and storage on an active component basis is less with these powdered precursors than their liquid equivalents. Inherent safety in handling is less and spillage unlikely to yield any chlorine dioxide gas or other toxic material unless water comes in contact with a mixture of the two powdered precursors. Nevertheless the powdered precursors have to be mixed into an aqueous reaction mixture which then becomes a stable solution of chlorine dioxide, and this involves some manual labor and handling. Therefore, appropriate Personal Protective Equipment, such as protective clothing and safety shoes or boots, goggles and gloves or gauntlets, are required. Since the components are powdered, a dust mask is also required. Even though dusting should not present a great potential hazard, appropriate precautions must be taken.

The two powdered precursors are mixed together to produce a 0.3% solution of chlorine dioxide (3000 ppm ClO_2) in water. The precursors have a shelf life of at least 5 years and the 0.3% solution of chlorine dioxide has a kinetic half-life greater than 30 days. A representation of the preparation of a 0.3% chlorine dioxide solution is illustrated in Figure 3. This “manual procedure may be suitable for preparing up to 10 liters, possibly 25 liters, of solution, a more convenient method and the method required to produce large quantities, up to 1000 liter, of the solution is to use a specially designed mixing or dissolution vessel. The chlorine dioxide solution can then be dosed directly from this vessel, using normal metering dosing pumps, directly to the system or area to be disinfected. Figure 4 shows a dosing unit specially designed for the safe preparation and dosing of chlorine dioxide solution

Direct Drive



The Ultimate Cooling Solution

Direct drive cooling tower systems from Baldor eliminate the need for mechanical components such as gearboxes, jack shafts and couplings – greatly reducing cooling tower maintenance and power consumption while increasing system reliability. The field-proven, high torque Baldor AC laminated motor is controlled by a purpose built ABB matched performance adjustable speed drive to provide optimal speed, quieter operation and lower energy use.

For new projects or retrofit applications, you can count on Baldor for the ultimate cooling solution.



baldor.com 479-646-4711

©2015 Baldor Electric Company

BALDOR
A MEMBER OF THE ABB GROUP



Download a QR reader app
and scan this code for
more information.
<http://esp.to/wj0cA6>

prepared from two powdered precursors. If desired the hand mixer can be motorized.

Although the resultant solution of chlorine dioxide is stable some chlorine dioxide can exist in gas or vapor phases above the solution. The dosing unit vents back into the vessel to prevent exposure to chlorine dioxide gas or vapor.

Depending upon proximity of applications and volumes of solution required, each application can be served by its own individual dosing unit, or several applications can be served from a single dosing unit. For intermittent dosing, dosing pumps would typically be fitted with timers.

Limitations

However good or innovative an idea or approach may be, there are always limitations or areas of application that may be more practical than others. The main limitation of the use of solid precursors is the volumes of chlorine dioxide solution that can be practically and conveniently prepared, which in turn limits application in cooling systems to those with comparatively small volumes. The target chlorine dioxide residual, chlorine dioxide demand and frequency of addition also need to be taken into account in deciding on volumes of solution required.

Such constraints in terms of practicality apply to many solid treatment product compositions that can be used for cooling water applications. This was not the case when solid sodium dichromate was the basis of cooling water treatments but these days chromate cannot be used for environmental reasons. The use of solid treatment chemicals and dispensing into cooling systems is not new and post the chromate era there have been units that have been designed to dose treatment chemicals from bottled solid components. These have been available for over a decade. There seems to be a resurgence in the interest of solid treatment chemicals or "controlled release" solid formulations or mixtures(14)(15) for use in cooling water treatment. The volume that can be practically treated is again a limitation. However, where practical the use of solid chemical products for the treatment of cooling water and in other applications undoubtedly can offer benefits in terms of safety, storage and handling.

Another limitation is the strength of chlorine dioxide solution that can be considered stable and "transportable". An ideal situation would be to have a "Stable" chlorine dioxide solution at high concentration available commercially, whereby the supplier does the preparation of the chlorine dioxide solution. Unfortunately here again there is a limitation on the "stability" of such solutions and in practice solutions available as supposedly "stabilized chlorine dioxide" are not chlorine dioxide but are in fact sodium chlorite or sodium hypochlorite solutions.

In practice the above solution stability would limit the use of solid precursors to produce a 0.3% solution of chlorine dioxide, which is stable for about one month. The next limitation involves practicality of safely handling the solid precursors with respect to weight of material to be handles. For manual handling this would be about 20 kg (44 lb). 20 kg of each solid precursor component would make 1000 litres (264 gallons) of 0.3% chlorine dioxide solution, or 3000 grams of chlorine dioxide. If this quantity were used over a one month period, it would equate to using 100 grams of chlorine dioxide per day. At a target applied concentration of 0.1 to 0.3 ppm ClO_2 , this would be capable of providing a daily shot dose to cooling systems with volumes of about 350 to 1000 m³ (92,500 to 264,000 gallons). Obviously less frequent dosing and/or lower target ClO_2 concentration would increase the capability of volume treated proportionally.

With equipment for transportation and lifting of weights greater than about 20 kg (44 lb), weight of the precursors are not the limiting factor since the precursors can be packaged in large polypropylene bags which are capable of holding up to 500 kg (1100 lb). However, the limiting factor now becomes the size of container within which the dissolution of the precursors and production of chlorine dioxide can be safely performed. This would be in the order of 1000 litres (264 gallons), so the ability to package precursors in plastic containers or bags with a net weight significantly greater than 20 kg (44 lb) is of little benefit.

Summary

There are several properties of chlorine dioxide which make it a preferred or alternative choice for certain applications. It does not react with ammonia so in ammonia contaminated waters, such as Fertilizer Plant Cooling Systems or systems reusing waste water, secondary treated sewage or "gray" water, which may create a high chlorine demand, chlorine dioxide can offer an economical alternative to sodium hypochlorite. In many cases chlorine dioxide is at least as effective as chlorine and in many cases has been proven to be more effective for control, disinfection and/or inactivation of viruses, pathogens, bacteria, algae and protozoa, although the mechanism of disinfection is not fully understood and may vary for different types of microorganism. Control of viruses, pathogens and protozoa can be of prime importance in cooling systems reusing Industrial or Municipal Waste Water as Make Up Water.

Unlike halogens such as chlorine and bromine, chlorine dioxide does not form THMs, and in fact may destroy some of the THM precursors. It does not form compounds contributing to the AOX of the treated water and it does not impart AOX to waters through inherent organically bound halogens within the molecule, which is the case for some non-oxidizing biocides such as Isothiazolin, Dibromonitropropanamide and Bromonitropropanediol.

Chlorine dioxide is relatively unaffected by pH within the range of pH 6 to 10, although cooling waters would typically be within a pH range of 7 to 9.

Although chlorine dioxide does not form THMs or AOX, some methods of preparation can result in significant amounts of residual free chlorine in the produced chlorine dioxide solution, in which case THM and AOX formation are likely to occur in this situation.

Chlorine dioxide has to be generated on site or in situ as it cannot be transported. Depending upon the method of generation, a chlorine dioxide generator is required, which adds capital and maintenance costs to the operation. Generators are designed to product solutions of less than 8,000 ppm since above this concentration the chlorine dioxide solution can create an explosive gaseous phase. However, when using liquid precursors, there is a potential danger that neat precursor solutions may be mixed accidentally resulting in a violent reaction and possible explosion. Unfortunately, such accidental mixing of liquid precursors has happened in the past. The use of solid precursors significantly minimizes, if not eliminate, many of the potential hazards associated with generation of chlorine dioxide.

References

1. Alavanja, M., Goldstein, I. and Susser, M., "A case control study of gastrointestinal and urinary tract cancer mortality and drinking water chlorination." In: Jolly, R., Brungs, W.A. and Cumming, R.B., eds, "Water Chlorination. Environmental Impact and Health Effects, Vol. 3, Ann Arbor, Ann Arbor Science Publishers, pp. 395-409, 1980.
2. Lykins, B.W. and Griese, M.H., "Using chlorine dioxide for trihalomethane control" Journal of the American Water



**20" - 22" Plastic Strip
Full Round Head, Screw-Shank Nails**
Type 304 and 316 stainless steel



Truss-Head Screws
Type 305 stainless steel



Self-Drilling Hex-Washer Head Screw
Type 305 and 316 stainless steel
with EPDM sealing washer

Your stainless-steel fastener source.



Common Annular-Ring-Shank Nails
Type 304 and 316 stainless steel



Spiral-Shank Nails
Type 304 and 316 stainless steel
with EPDM sealing washer



Self-Drilling Hex-Washer Head Screws
Type 305 and 316 stainless steel

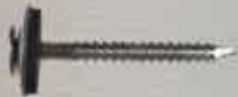

Ring-Shank Nails
Type 304 and 316 stainless steel
with EPDM sealing washer



Common Spiral-Shank Nails
Type 304 stainless steel



Bugle-Head Wood Screws
Type 305 and 316 stainless steel



Hog Rings
Type 304 stainless steel



Fencing Staples
Type 304 stainless steel



EPDM Sealing Washers
Type 304 and 316 stainless steel



Simpson Strong-Tie is your source for fasteners for building and repairing cooling towers. Our wide selection of stainless-steel bulk and collated nails, screw/nail washer assemblies, and self-drilling screws are easy to install and provide superior results in wood, fiberglass and corrosive environments. Fasteners are available in 304, 305 and 316 stainless steel.

To learn more about the entire line of Simpson Strong-Tie® fasteners for cooling tower construction and repair, call (800) 999-5099 or visit strongtie.com/fasten.



Works Association, 78(6), 88, June 1986.

3. Narkis, N. and Kott, Y., "Comparison Between Chlorine Dioxide and Chlorine for Use as a Disinfectant of Wastewater Effluents", *Water Science & Technology* Vol 26 No 7-8 pp 1483-1492, IWA Publishing 1992.
4. Junli, H., Li, W., Nenqi, R., Li, L.X., Fun, S.R. and Guanle, Y., "Disinfection effect of chlorine dioxide on viruses, algae, and animal planktons in water." *Wat. Res*; 31, (3): 455-460, 1997.
5. Roberts, P.V., Aieta, E.M., Berg, J. D., and Chow, B. "Chlorine Dioxide for Wastewater Disinfection: A Feasibility Evaluation," Technical Report No 251, Civil Engineering department, Stanford university, Palo Alto, California, October 1980.
6. White, G.C., "Handbook of chlorination and alternative disinfectants.", fourth Edition, John Wiley & Sons, Inc., New York, New York, 1999.
7. Gates, Don P., "The Handbook Of Chlorination", *Water Disinfection Series*, 1998.
8. McCarthy, J.A., "Chlorine dioxide for the treatment of water supplies." *J.N. Engl. Water Works Assoc.* 59:252-264, 1944.
9. Synan, J.F., MacMahon, J.D. and Vincent, G.P., "Chlorine dioxide in potable water treatment." *Water Eng.* 48:285-286, 1945.

10. Vincent, G.P., MacMahon, J. D. and Synan, John F., "The Use of Chlorine Dioxide in Water Treatment." *American Journal of Public Health and the Nation's Health*; Vol. 36, No. 9, pp. 1035-1037, September 1946.
11. Hoehn, R., "Chlorine dioxide Use in Water Treatment: Key issues" in *Chlorine dioxide: Drinking Water Issues*, Second International Symposium, Denver, Colorado, 1993.
12. Yin, G. and Ni, Y., "Using Hydrogen Peroxide in a Methanol-Based Chlorine Dioxide Generation Process", *Industrial & Engineering Chemistry Research*, Vol. 38, Issue 9, pp. 3319-3323, 1999.
13. Gordon, G., Sloomackers, B., Tachiyashiki, S., Wood III, D.W., *Journal American Water Works Association* 1990, 82(4), 160-165.
14. Emery, K., "Application of Controlled Release Chemistry to Cooling Towers," TP-13-22, *Cooling Technology Institute Annual Conference*, Corpus Christi, Texas, February 2013.
15. Hunter, M., "A Review of Solid-Form Scale and Corrosion Inhibitors," *Waterline*, Journal of the Water management Society, United Kingdom, Summer 2014.

Table 1
Oxidizing Biocides

Chemical	Form	Molecular Formula
Chlorine gas	Gas	Cl ₂
Sodium hypochlorite	Aqueous solution	NaOCl
Calcium hypochlorite	Solid powder	Ca(OCl) ₂
Sodium dichloroisocyanurate	Solid pellets	
Trichloroisocyanurate	Solid pellets	
Sodium Bromide	Aqueous solution	NaBr + HOCl → HOBr + NaCl <i>Activated with Cl₂ gas or NaOCl</i>
Bromochlorodimethylhydantoin	Solid granules or pellets	
Bromine chloride	Stabilized solution	BrCl
Chlorine Dioxide	Aqueous solution of gas	ClO ₂
Hydrogen Peroxide	Aqueous solution	H ₂ O ₂
Peracetic Acid	Aqueous solution	
Ozone	Gas	O ₃

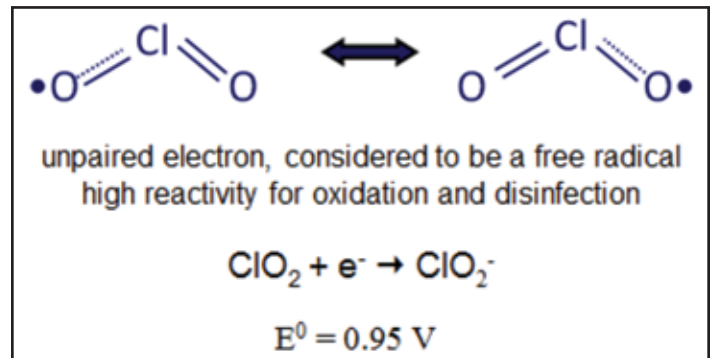

Figure 2. Chlorine Dioxide Free Radical Oxidizing Agent.

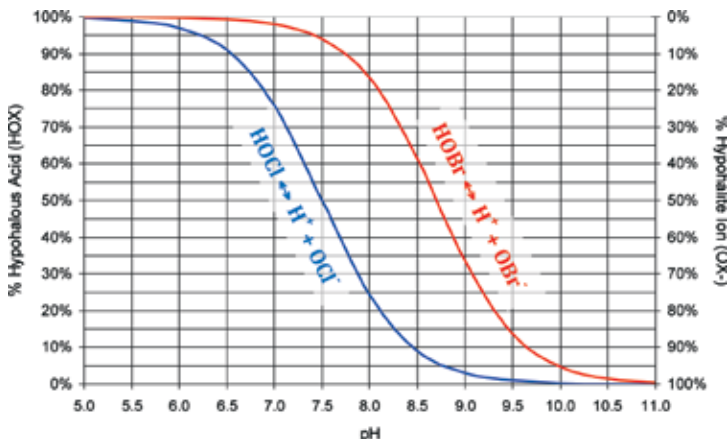

Figure 1. Dissociation Curves for Chlorine and Bromine

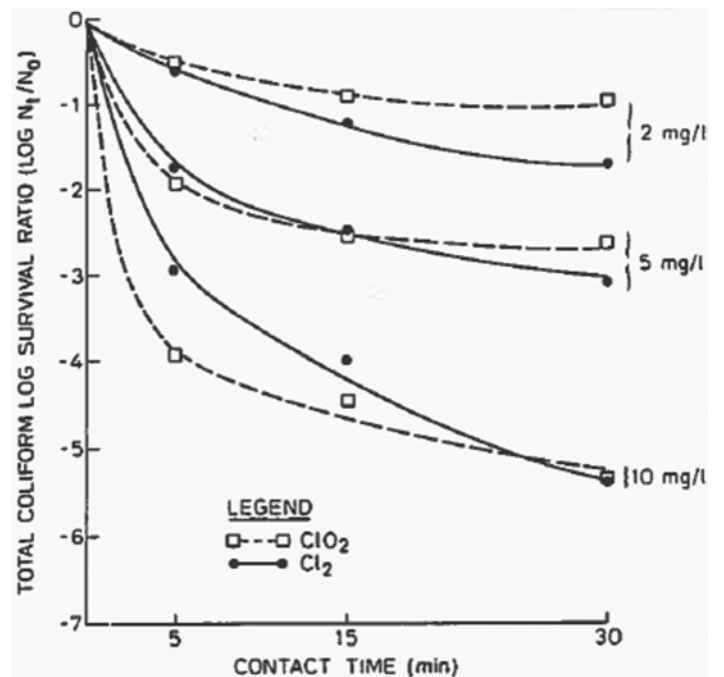

Figure 3. Relative Efficacy of Chlorine Dioxide and Chlorine

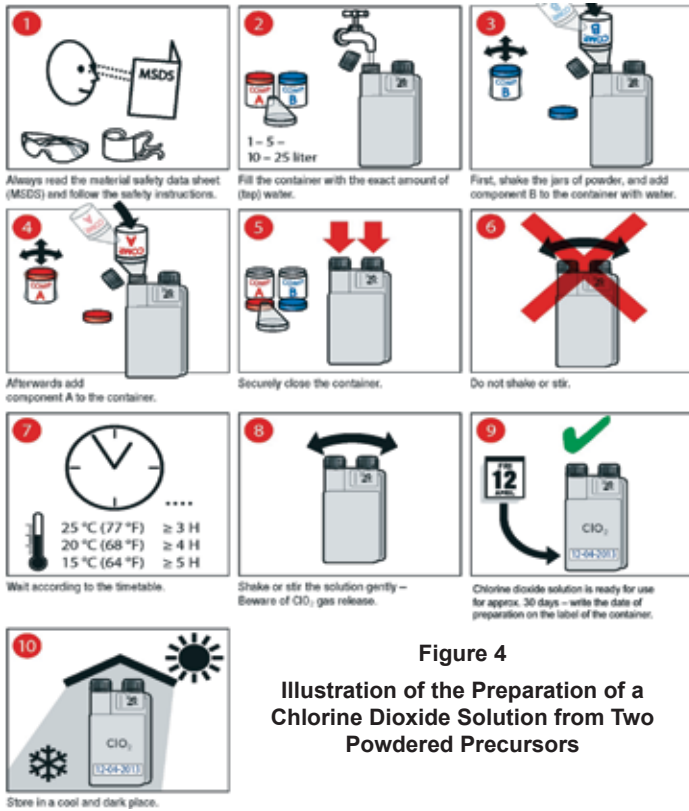

Figure 4
Illustration of the Preparation of a Chlorine Dioxide Solution from Two Powdered Precursors

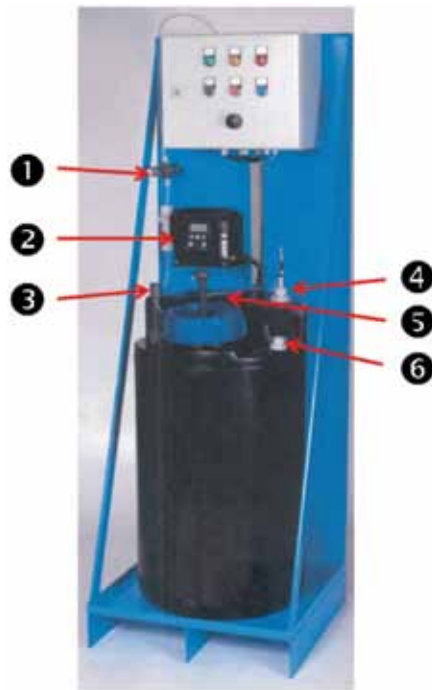

Figure 5.
Basic Dosing Skid Components required for the preparation of Chlorine Dioxide from Powdered Precursors.

- 1 Pressure Sensor and Cut Off Valve
- 2 Dosing Pump
- 3 Lance and Level Switch
- 4 Level Sensor
- 5 Mixer (Hand or Electrical)
- 6 Water Connection



COOLING TOWER SPECIALISTS

Competitive Pricing and Quantity Discounts on all Cooling Tower Components
NOW STOCKING
Amarillo Gear Reducers



TOWER PERFORMANCE, INC.

Serving the Cooling Tower Aftermarket

Field Services Include:
Repair & Overhaul
Scheduled Maintenance
Inspection & Evaluations
Emergency Service



800-314-1695

jfritz@tpitx.com

www.CoolingTowerComponents.com



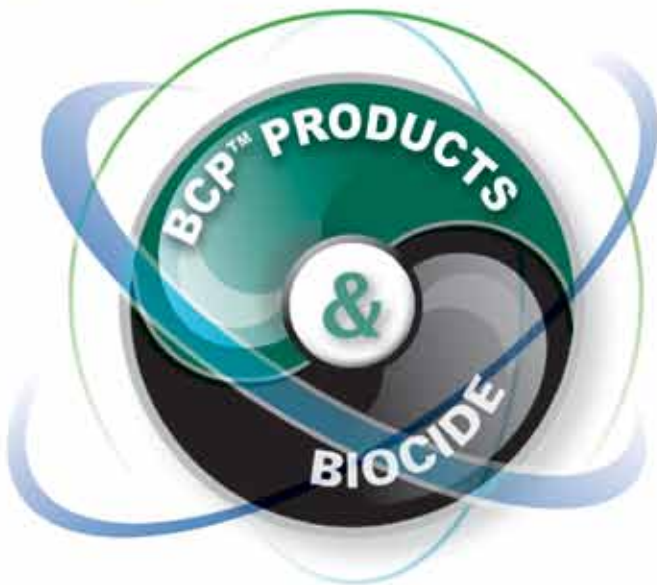

Figure 6. Design and Arrangement of Dosing Equipment for Chlorine Dioxide Prepared From Powdered Precursors for Various capacity Applications.

BCP™
PRODUCTS

Clean it Up and Keep it Clean!™

BCP™ products provide organic deposit cleaning by penetrating and dispersing surface foulants in industrial cooling water systems. Applied with biocides, BCP™ products provide a highly effective Biofilm Control Program (BCP™), yielding improvements in biofilm, corrosion and scale control.



AMSA's BCP™ Product Line

- BCP™ 1000 Classic DTEA II™
- BCP™ 2000 New Biofilm Control Program Products
- BCP™ 3000 New and Classic DTEA II™ Solid Products
- BCP™ 4000 All-in-One Formulations*
- BCP™ 5000 Specialty Products – Geothermal

*Please call us for more details

Before BCP™ Chemistry

After BCP™ Chemistry



Without BCP™ Chemistry

Using BCP™ Chemistry

“
A Biofilm Control Program (BCP™), based on the well-reputed DTEA II™ chemistry, results in a clean industrial water system.”

Call Us Today!
To get the protection
you need!
888 739-0377



AMSA, Inc.™
4714 S. Garfield Rd. • Auburn, Michigan, USA • 48611
Tel: (989) 662-0377 Fax: (989) 662-6461
sales@amsainc.com
www.amsainc.com

From Vision To Practical And Cost Effective Design

Roy A. Holliday, GE Water & Process Technologies, Europe.
Shereif Alsayed, GE Water & Process Technologies, Middle East and Africa.
Amr Eladawy, Abu Qir Fertilizers Co., Alexandria, Egypt.

Abstract

A major Middle East Fertilizer Plant, with a long history of successfully reusing water in open evaporative cooling systems, had a mission to further reduce water consumption, effluent discharge and operating costs. Various approaches were proposed and appraised. This paper discusses options available for applicable approaches to reduce water consumption, effluent and operating cost; with an ultimate aim to achieve the vision of Zero Liquid Discharge.

Introduction

The Abu Qir Fertilizer site, located in Alexandria, Egypt, produces nitrogenous fertilizers and since the first plant, AQ I, was commissioned in 1979 has expanded to three plants with a total production capacity of 8,650 metric tons of nitrogenous fertilizer per day. AQ I produces prilled urea, AQ II, built in 1991, produces ammonium nitrate granules and AQ III, built in 1998, produces urea granules. In addition there is a Nitrogen Phosphorus Potassium Plant (NPK) and a Urea Ammonium Nitrate Plant (UAN) on the Alexandria site. As designed, the total Waste Water produced by the plants is 1,395 m³/h (6,142 gpm), the majority of which (79%) would be blowdown from the cooling systems and 16% waste condensate.

Past Undertakings To Manage Water Usage

Waste Water produced by the plants consists mainly of Blowdown Water from the Cooling Systems. Other significant contributors to the Waste water are Waste Condensate Water and Regeneration Water from the Demineralization Plants.

Initially Waste Water from the AQ I Plant was 505 m³/h (2,220 gpm). With an additional 400 m³/h (1,760 gpm) from AQ II Plant the cumulative Waste Water produced by both plants in 1991 was 905 m³/h (3,985 gpm). The addition of the AQ III Plant added a further 490 m³/h (2,160 gpm). In theory, or by design, Waste Water produced with all plants in operation is in the order of 1,395 m³/h (6,140 gpm).

In the design of some Cooling System the Cycles of Concentration or Concentration Factor at which the Cooling System can operate is limited, such as a limitation of chloride concentration in the Cooling Water in systems containing Austenitic Stainless Steel. This was the case in the AQ II Nitric Acid Plant Cooling System which operated at low Cycles of Concentration making the chemistry of the Cooling Water Blowdown from this cooling system a candidate for cascading to another cooling system. This was practiced and 200 m³/h (880 gpm) of blowdown water from the AQ II Nitric Acid Plant was cascaded to the AQ II Ammonia Plant Cooling System as partial Make Up Water. In addition, 50 m³/h (220 gpm) of process condensate from the ammonia processes of AQ I and AQ II were reused, after pretreatment, as partial Make Up Water.



Roy A. Holliday

When AQ III became operational, a similar scenario of low Cycles of Concentration was imposed on the AQ III Urea Plant Cooling System. AQ I Cooling System had always been operated at low Cycles of Concentration. 150 m³/h (660 gpm) of Blowdown Water from AQ III Urea Plant Cooling System and 300 m³/h (1,320 gpm) of Blowdown Water from AQ I Plant Cooling System were reused as partial Make Up Water in AQ III Ammonia Plant Cooling System. In addition, 120 m³/h (530 gpm) of Urea Plant Waste Condensate from AQ I and AQ III Plants were reused.

By reusing Cooling System Blowdown Water and Waste Condensate Water, theoretical Waste Water and Cooling System Make Up Water volumes were reduced by 850 m³/h (3,740 gpm), a reduction in Waste Water of 39%. This is a significant move in terms of Water and Waste Management but still leaves room for improved recovery of Waste Water in order to reach the goal of Zero Liquid Discharge.

Options For Further Water Management

Successful water reuse projects require the input of several different disciplines, careful and accurate assessment of hydraulics, water chemistry, operations, and an open minded approach and discussions. In order to approach the goal of Zero Liquid Discharge (ZLD) significant capital investment would be required to improve the water quality of Waste Streams which in turn renders them suitable for reuse as Make Up Water to Plant Cooling Systems. Return on investment would be achieved in many areas.

- Reduced use of Treated Water.
- Reduced consumption and costs of chemical for pretreatment of Canal Water.
- Reduced handling and disposal costs of sludge from the cold lime softener treating incoming Canal Water.
- Reduced frequency of backwash and subsequently Backwash Water from the Pretreatment Filters.
- Increased EDR membrane life and reduced maintenance costs.
- Reduced Blowdown from Cooling Systems achieved by operating at higher Cycles of Concentration and change of Cooling Water Treatment Programs.
- Increased run length between regeneration of Demineralization Plants and reduced regenerant and rinse water consumption and discharge.
- Increased ability to remove process contaminants in the Demineralization Plants.
- Production of Ammonium Sulphate as a byproduct which can be retailed.
- Reduced Waste discharge and subsequently reduced consumption of Sodium Chloride for adjustment of Total Dissolved Solids concentration making it suitable for discharge to sea (Local Regulation Compliance), and other chemicals used to treat the Waste Water.

The hydraulics of individual plants and interconnections are very complex, as illustrated in Figure 1. Implementation of the Reclaimed Waste Water Project and reuse of Reclaimed Waste

Carbon Fiber Composite Drive Shafts / Couplings for cooling tower applications



Advantages

- **UV stabilized**
- **Easy installation**
- **Superior fatigue life**
- **High misalignment capability**
- **Smoother operation**
- **High strength to weight ratio**
- **Inherent corrosion resistance**

Already installed in

India | Indonesia | Thailand |
Turkey | Saudi Arabia | Italy

Approved & supplied to
NTPC (India).

ATEX (CE) certified



North Street Cooling Towers Pvt. Ltd.

Email: sales@nsctpl.in

Website: www.nsctpl.com

Fax: +91-120-2788574

Phone: +91-120-2788571 / 72



An ISO 9001:2008(QMS), 14001:2004(EMS) &
OHSAS 18001:2007 Certified Company

Water will enable operation of some systems at higher Cycles of Concentration and in some cases necessitate a change of the cooling water treatment program.

Current Plant Cooling System Hydraulics and Treatment Programs

The AQ I Plant Cooling System, operating at 1.75 Cycles of Concentrations, uses filtered cold lime softened Canal Water or “Treated Water” solely as Make Up Water. The designed chemistry of Canal Water before and after treatment is given in Table I. The current treatment applied in the AQ I Plant Cooling System is a zinc phosphate program, complimented by a phosphonate for inhibition of calcium carbonate scale and a sulphonated terpolymer for inhibition of calcium and zinc phosphate and for general dispersant properties. The blowdown from the AQ I Plant is used as partial Make Up to the AQ III Ammonia Plant Cooling System. A part of the blowdown from the AQ III Urea Plant Cooling System, operating at 2.2 Cycles of Concentration, is used to supply the remaining Make Up water required for the AQ III Ammonia Plant Cooling System, operating at 3.1 Cycles of Concentration. The remainder of the blowdown from the AQ III Urea Plant Cooling System goes to waste. Make Up water for the AQ III Urea Plant Cooling System is a mixture of treated water and condensate from the AQ III process streams. Utilizing the treatment chemicals in the blowdown water cascaded from the AQ I Plant Cooling System and the AQ III Urea Plant Cooling System, the AQ III Ammonia Plant Cooling System also uses a zinc phosphate, phosphonate, sulphonated terpolymer program, at higher chemical concentration and pH than the other two cooling systems.

The AQ II Plant Cooling Systems are not interlinked with the AQ I and AQ II Plant Cooling Systems because of distance between the plants. The AQ III Nitric Acid Plant Cooling System operates at low Cycles of Concentration, 1.4 cycles, and cascade blowdown from this cooling system provides some of the Make Up for the AQ II Ammonia Plant Cooling System. Treated water is used to provide the remainder of the Make Up for the AQ II Ammonia Plant Cooling System.

Chlorine gas is dosed continuously to control microbiological activity in all of the site cooling systems. Chlorination is supplemented with bromination three hours per day by feeding a sodium bromide precursor together with the chlorine gas during periods when ammonia leakage into the cooling water occurs. A mixture of non-oxidizing biocides, quaternary ammonium salt and isothiazalin based, are dosed on a monthly basis and also utilized as an emergency response to ammonia leakage into the cooling water.

Plant Design to enable Reuse of Waste Water Streams

In order to achieve Zero Liquid Discharge the various Waste Water streams require treatment to improve the quality of the water prior to reuse as Make Up to the cooling systems and/or feed water to demineralization plants. This would involve processes to soften and remove phosphate, ammonia and nitrogen compounds from the waters. Ultrafiltration and reverse osmosis will be used to remove microorganisms, suspended and dissolved solids from the water. The Reclaimed Waste Water quality will be low dissolved solids water with a total nitrogen concentration less than 10 ppm N and ammonia concentration less than 3 ppm NH₃. Details and configuration of the Waste Water Recovery Plant are shown in Figure 2. The total flow rate of Waste Waters from the plants is in the order of 650 m³/h (2860 gpm) which when processed and turned into good quality Reclaimed Waste Water will provide 550 m³/h (2420 gpm) of treated water for Make Up to the site cooling systems

and/or feed water to demineralization plants. The remaining 100 m³/h (440 gpm) of Reclaimed Waste Water will be discharged to the sea. Local regulations require that the Total Dissolved Solids (TDS) concentration of waters discharged to the sea is $\pm 5\%$ of the TDS of the sea water to which it is discharged. Sodium chloride is added to the water discharged to the sea in order to equilibrate the TDS to $\pm 5\%$. Obviously the consumption of sodium chloride will reduce significantly since the quantity of water discharged to the sea will be reduced by 85% compared to the current operation. Because of distances and logistics the Reclaimed Waste Water will only be used in the AQ I and AQ III Plants.

Proposed Changes to Operating Cycles and Treatment Programs

There are several options for the reuse of Reclaimed Waste Water as Make Up to the cooling systems and/or feed water to the demineralization plants. Two options are the most attractive. The option that will be implemented is Option 1 (Figure 3), which utilizes 250 m³/h (1100 gpm) of Reclaimed Waste Water as feed water to demineralization plants. Option 2 (Figure 4), which does not use any Reclaimed Waste Water in the demineralization plants, would only be used on an emergency basis.

Upon completion of the project, the treatment program used in the AQ III Urea Plant Cooling System will change to a neutral pH phosphate program due to the high phosphate carryover from the cascaded blowdown waters, mainly from the AQ I Plant Cooling System. The current chemical concentrations and pH used in the AQ III Ammonia Plant Cooling System, 6 to 8 ppm total phosphate, 1 to 2 ppm zinc and pH 8.0 to 8.5, will change to 17 to 23 ppm total phosphate, 2 to 4 ppm zinc with the cooling water pH controlled within the range of pH 7.3 to 7.6 using sulphuric acid.

The treatment program of the AQ I Cooling System will also change from an alkaline program to a neutral pH program upon integrating Reclaimed Waste Water as partial Make Up water. Higher orthophosphate concentrations will be required, compared to the existing concentration, in order to obtain good anodic corrosion inhibition at the lower pH. Increasing orthophosphate to the required concentration will be a challenge as it will impact the calcium and zinc phosphates deposition potential in the AQ III Ammonia Plant Cooling Water because 50 % of its Make Up water is supplied from cascade blowdown from the AQ I Plant Cooling System. In the AQ I Plant Cooling System the treatment program would be designed to operate in the range of 9 to 15 ppm orthophosphate and 1 to 3 ppm zinc. The terpolymer concentration would be increased to inhibit deposition of calcium and zinc phosphates.

Incorporating Reclaimed Waste Water into AQ I Cooling System will reduce Treated Water requirement for the cooling system by 50%. It would also enable the cooling system to operate at 1.8 Cycles of Concentration as opposed to the current 1.75 cycles. Although hydraulically and chemically higher Cycles of Concentration are possible, only slight increase of the Cycles of Concentrations in the AQ I Cooling System will be implemented in order not to significantly reduce the blowdown rate which provides partial Make Up water to the AQ III Ammonia Plant Cooling System. The reduction Blowdown Water cascaded from the AQ I Cooling System to the AQ III Ammonia Plant Cooling System will not impact the Make Up water supplied as per the requirement, because, in theory, Cycles of Concentration in the AQ III Ammonia Plant Cooling System can be increased from the current 3.1 cycles to 3.5 cycles without exceeding chloride concentration guideline limits. The projected increase in cycles would save 504 m³/day (2220 gpm) of Make Up Water. About 88 % of the Make Up Water would be supplied by blowdown from the AQ I Plant Cooling System and

12% by blowdown from the AQ III Urea Plant Cooling System

The AQ III Ammonia Plant Cooling System AQ III Urea Plant Cooling System will not be impacted by the Reclaimed Waste Water Project at this stage. This is due to the limited capacity of the Reclaimed Waste Water Unit to fulfill the water requirement for the AQ I and AQ III Plant Cooling Systems and demineralization plants.

For the cooling systems having a limitation on chloride concentration of 110 ppm Cl, optimization of Cycles of Concentration could tolerate a maximum of 2.4 cycles and the cooling water would still be in compliance with the chloride limit. In addition of the limitation on chloride concentration, optimization has to also consider process condensate used as partial Make Up in AQ III Urea Plant Cooling System and cascaded blowdown rates required to satisfy Make Up water requirements for AQ III Ammonia Plant Cooling System. Treated Canal Water will be used to fulfill any additional water required for Make Up to AQ I Plant Cooling System and AQ III Urea Plant Cooling Systems.

The AQ II Cooling Systems will not receive any Reclaimed Waste Water because of its distant location from the Reclaimed Waste Water Plant, but Waste Water from the AQ II pit will be sent to the Reclaimed Waste Water Plant.

Hydraulic data for the current operation and future options are given in Table IIa and Table IIb. Table III shows how the various water sources and discharge are distributed. Compared to the current operation, Option 1 would reduce Treated Water consumption by 26% and Option 2 by 28%. This reduction would obviously also seen in chemicals used to pretreat the Canal Water and in backwash frequency and backwash water used and discharged from the pretreatment filters. Although Option 1 produces a slightly lower reduction in Treated Water consumption, in this option the use of 250 m³/h of Reclaimed Waste Water r as feed to the Demineralization Plants will increase run length of the ion exchange units and reduce usage and discharge of chemicals and water used for regeneration of resins. A schematic of the designs for options reusing Reclaimed Waste Water are shown in Figures 3 and 4.

Projected Savings

The project has not yet been completed so projected savings cannot be precisely quantified. The major savings are obtained by reduced Treated Water required as Make Up Water for AQI and AQ III Cooling Systems, annual savings are projected to be in the order of 3 million m³/year (793 million gallons per year), depending upon which Option is used. In addition, there are savings obtained through the reduction of Treated Water used as feed for Demineralization Plants. The savings are not just in the cost of the water, but in chemicals used to pretreat the Canal Water.

Use of lower dissolved solids water in the Demineralization Plants would increase un lengths between regeneration and subsequently result in reduced consumption of hydrochloric acid and caustic for regeneration.

Projected savings in Pretreatment Chemicals and Chemicals for Regeneration are shown in Table IV, and amount to about \$340,000 per year on these chemicals alone. In addition there are large savings in reduced disposal costs of sludge from the Pretreatment Plant. In addition there are large savings in reduced sludge disposal volumes and costs from the Pretreatment Plant.

The volume of water discharged to the sea will be reduced but since the Reclaimed Waste Water discharged to sea will have a low TDS and higher concentration of sodium chloride to equilibrate this water to sea water TDS will be reduced but not directly pro

rata to comparative volumes of the waters discharged.

Some of these savings will be slightly off-set by chemicals required in the Waste Water Recovery Plant Process. However, revenue obtained through the retail of Ammonium Sulphate Byproduct produced in the Waste Water Recovery Process will make the overall process and project profitable and economically viable.

Tables

	Raw Water Source (Canal Water)	Lime Softened Canal Water (Treated Water)
pH	9.0	10.0
TDS	380 ppm	220 ppm
Methyl Alkalinity	190 ppm CaCO ₃	38 ppm CaCO ₃
Total Hardness	185 ppm CaCO ₃	112 ppm CaCO ₃
Calcium Hardness	110 ppm CaCO ₃	75 ppm CaCO ₃
Magnesium Hardness	75 pm CaCO ₃	37 ppm CaCO ₃
Chloride	80 ppm Cl	80 ppm Cl
Sulphate	40 ppm SO ₄	40 ppm SO ₄
Silica	3 ppm SiO ₂	3 ppm SiO ₂
Iron	1.8 ppm Fe	0.2 ppm Fe
Turbidity	30 NTU	5 NTU
Permanganate Value	30 ppm O ₂	5 ppm O ₂

Table I
Design Water Chemistry of Canal Water and Treated Water

	Current	Reclaim Option 1	Reclaim Option 2
AQ I	Evaporation 287 m ³ /h	Evaporation 287 m ³ /h	Evaporation 287 m ³ /h
Cycles	1.75 cycles	1.8 cycles	2.3 cycles
Make Up	670 m ³ /h Treated Water	346 m ³ /h Treated Water	325 m ³ /h Treated Water
		300 m ³ /h Reclaimed Waste Water	183 m ³ /h Reclaimed Waste Water
	Total Make Up 670 m ³ /h	Total Make Up 646 m ³ /h	Total Make Up 508 m ³ /h
Blowdown	383 m ³ /h Cascaded as MU to AQ III NH ₃	359 m ³ /h Cascaded as MU to AQ III NH ₃	221 m ³ /h Cascaded as MU to AQ III NH ₃
AQ III Urea	Evaporation 98 m ³ /h	Evaporation 98 m ³ /h	Evaporation 98 m ³ /h
Cycles	2.2 cycles	2.4 cycles	2.4 cycles
Make Up	130 m ³ /h Treated Water	118 m ³ /h Treated Water	118 m ³ /h Treated Water
	50 m ³ /h Process Condensate	50 m ³ /h Process Condensate	50 m ³ /h Process Condensate
	Total Make Up 180 m ³ /h	Total Make Up 168 m ³ /h	Total Make Up 168 m ³ /h
Blowdown	26 m ³ /h Cascaded as MU to AQ III NH ₃	29 m ³ /h Cascaded as MU to AQ III NH ₃	50 m ³ /h Cascaded as MU to AQ III NH ₃
	56 m ³ /h Sent to Waste	41 m ³ /h To Waste Recovery Plant	20 m ³ /h To Waste Recovery Plant
	Total Blowdown 82 m ³ /h	Total Blowdown 70 m ³ /h	Total Blowdown 70 m ³ /h
AQ III NH₃	Evaporation 277 m ³ /h	Evaporation 277 m ³ /h	Evaporation 277 m ³ /h
Cycles	3.1 cycles	3.1 cycles	3.5 cycles
Make Up	383 m ³ /h Cascaded from AQ I	359 m ³ /h Cascaded from AQ I	221 m ³ /h Cascaded from AQ I
	26 m ³ /h Cascaded from AQ III Urea	29 m ³ /h Cascaded from AQ III Urea	50 m ³ /h Cascaded from AQ III Urea
			117 m ³ /h Reclaimed Waste Water
	Total Make Up 409 m ³ /h	Total Make Up 388 m ³ /h	Total Make Up 388 m ³ /h
Blowdown	130 m ³ /h Sent to Waste	111 m ³ /h To Waste Recovery Plant	111 m ³ /h To Waste Recovery Plant

Table IIa
AQ I and AQ III Cooling System Hydraulics

aggreko



Cooling Solutions To Grow Your Business

Aggreko Regional Office

4540 Kendrick Plaza Drive, Suite 100, Houston, TX 77032, United States

T: 888.869.2108

Aggreko operates from over 200 locations throughout the world.
For the location nearest you, please go to: www.aggreko.com/contact



When a cooling tower fails or when a short-term problem overwhelms the capacity of your tower, Aggreko Cooling Tower Services (ACTS) is the solution.

We have over 50 years' global experience, 24/7 service from technical experts and the largest fleet of modular cooling towers in the industry. Aggreko can help you address emergencies, maximize production, and keep your operations running smoothly when the heat is on.



Aggreko, Temperature Control Specialists across North America

www.aggreko.com

Current and Immediate Future <i>Not impacted by the Reclaim Project</i>	
AQ II HNO ₃	Evaporation 146 m ³ /h
Cycles	1.4 cycles
Make Up	311 m ³ /h Treated Water
	Total Make Up 311 m ³ /h
Blowdown	250 m ³ /h Cascaded as MU to AQ II NH ₃
	115 m ³ /h Sent to Waste
	Total Blowdown 365 m ³ /h
AQ II NH ₃	Evaporation 192 m ³ /h
Cycles	3.0 cycles
Make Up	38 m ³ /h Treated Water
	250 m ³ /h Cascaded from AQ II Urea
	Total Make Up 288 m ³ /h
Blowdown	96 m ³ /h Sent to Waste
	Total Blowdown 96 m ³ /h

Table IIb
AQ II Cooling System Hydraulics

	Current	Reclaim Option 1	Reclaim Option 2
Treated Water	1,348 m ³ /h	1,013 m ³ /h	997 m ³ /h
Process Condensate	50 m ³ /h	50 m ³ /h	50 m ³ /h
Reclaimed Waste Water		300 m ³ /h	300 m ³ /h
Discharge to Reclaimed Waste Water Plant	399 m ³ /h	363 m ³ /h	342 m ³ /h

Table III

Usage and Distribution of Waters in the Plant Cooling Systems

Lime	Alum	Polyelectrolyte	HCl	NaOH
\$163,314	\$12,810	\$2,464	\$44,499	\$116,928

Table III

Projected Annual Savings in Pretreatment and Regeneration Chemicals

Figures

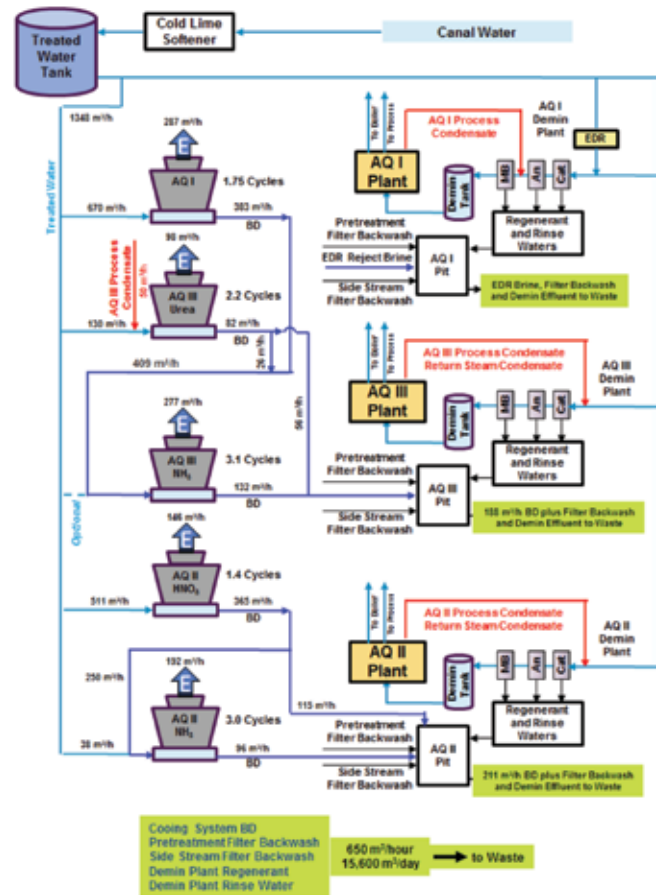

Figure 1

Current Operation of Cooling Systems

FRP Shapes & Decking

Grating - Molded and Pultruded

CCA Treated High Quality Lumber & Plywood

Complete Fabrication Facility
Super Competitive Pricing
Lightening Fast Customer Service

GAIENNIE LUMBER COMPANY
Industrial Products Division

BOX 1240 • OPELOUSAS, LA 70571-1240
800-326-4050 • 337-948-3067
Email: CT@Galennie.com



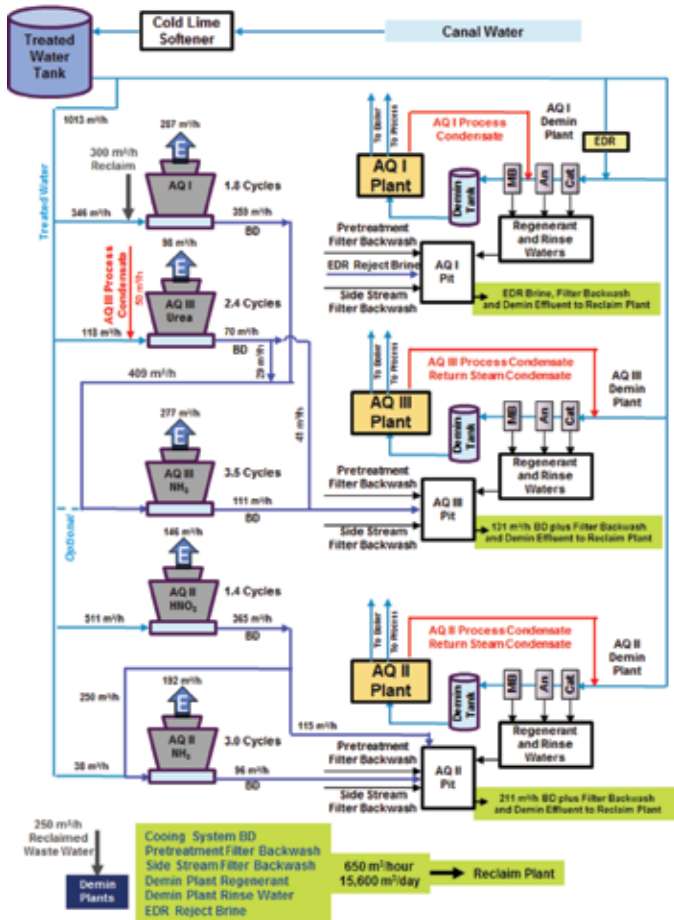

Figure 2

Waste Water Recovery Plant Design and Configuration

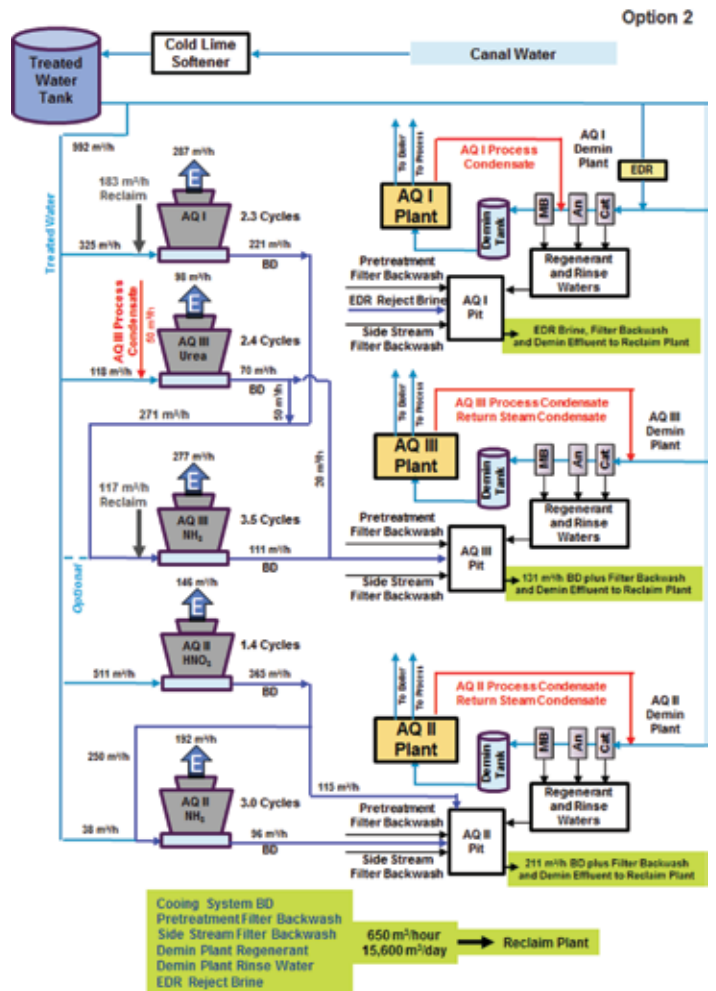

Figure 4

Reclaimed Waste Water Reuse Option 2

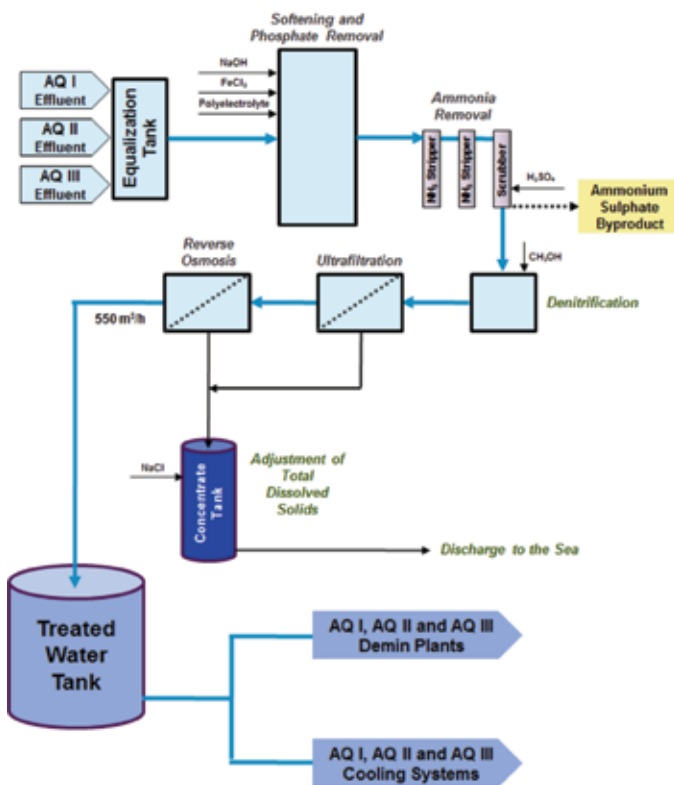

Figure 3

Reclaimed Waste Water Reuse Option 1



Study on the Combustion of Polymers Within Cooling Towers

Chris Bowman, Jia Shen; Brentwood Industries

1.0 Introduction

Risk: The outcome of analyzing the probability of something happening and the associated consequence of that thing, or things, happening. The cooling tower industry has attempted to convey to their customers what the fire risk factors may be for a particular cooling tower by adapting existing test methods designed for other industries and trying to make them fit its industry and products. From tests that were designed to determine the flame spread potential for wall covering materials in buildings to tests conducted by insurance companies designed to show a cooling tower's ability to contain a fire event, the industry seems to not be able to provide a good recommendation or system of methodology to an owner on whether or not the polymers within a cooling tower pose a high or low risk of catching on fire. Not only catching on fire to start with, but also the risk potential for a polymer to sustain a flame and to continue the combustion process. This paper will discuss the science behind the inherent burning characteristics of polymers that are widely used as the heat transfer media, or fill media, within cooling towers, including how they burn and how flame retardants work to minimize the burning characteristics. Additionally, this paper will look at the ignition characteristics with respect to cooling towers in real-world scenarios outside of a laboratory and will also look at the current test methods that the cooling tower industry has borrowed to determine if the testing outcomes provide an accurate portrayal to an end user of the total flammability risk for a particular fill media. Upon review of these items we can then attempt to determine if the current test methods being used are sufficient to allow an owner to be able to evaluate the risk involved with selecting one type of cooling tower fill over another.

What is "fire" and how does it work? Three preliminary components; oxygen, heat, and fuel are necessary to start and sustain a combustion process. All three are needed for combustion, so remove one and the process won't be able to be completed. The burning/combustion of polymer materials is a complex process that consists of a series of coupling reactions both in condensed phase and gas phase and is affected by multiple factors.

Polymer molecular chains don't directly participate in the combustion reactions due to their high molecular weight and entanglements that make it difficult to vaporize and to react with oxygen in the gas phase. For that reason the heat that is applied on the polymer condensed phase surface has to be sufficient to initiate the degradation of the molecular chain. The heat/energy may come from either an ignition event or the feedback heat of the adjacent burning flame that sustains the combustion process. The mechanism of heat transfer, degradation, and mass transfer of combustible fragments in the condensed phase are well investigated and reviewed by Takashi et al.^[1]



Chris Bowman

With sufficient combustible fuel, which was from the degradation of the polymer, and oxygen in the appropriate ratio, the flame can be ignited by either auto ignition or pilot ignition. It is difficult to clearly distinguish the two ignition mechanisms. Generally, pilot ignition is generated by creating a region of extreme high temperature in the gas phase. Meanwhile, auto ignition is caused by thermal radiation, heat flux, and hot surfaces^[2].

The primary reaction in the flame of polymer combustion is free-radical reaction. The radicals in hydrocarbon flames consist of the products that pyrolysis fragment from the degradation of polymer molecular

chains, such as H•, OH•, and O•. The free radical reactions release heat to facilitate the degradation of the polymer's condensed phase to provide more fuel and to sustain the flame.

The understanding of polymer combustion provides a basis to better analyze what conditions need to be present to start a cooling tower fill media fire, sustain that fire, and what conditions are needed for fire propagation. We will need to look at the properties of the two most widely used polymers for cooling tower fill media: Polyvinyl chloride (PVC) and Polypropylene (PP). By looking at the combustion properties of these two materials and then looking at the existing methods for testing cooling tower fill media, we can discuss and evaluate if the existing tests provide for a complete and accurate picture of a cooling tower fill media's potential for fire risk. Since most cooling tower fires are started while the tower is shut down by a heat source being introduced from above the fill media, like sparks and hot metal shavings from metal grinding and welding operations, it is important to be able to provide an accurate picture of the fire potential risk under these types of situations.

2.0 Flammability And Flame Retardant Strategy For PP And PVC

PP and PVC are two types of polymers that are widely used as the base polymer in the construction of heat transfer media within cooling towers. Some of the typical flame properties of PP and PVC are shown in Table 1:

	PP*	PVC*
Limiting Oxygen Index (LOI, %)	17	45
Ignition Temperature (°C)/(°F)	550/1022	450/842
Auto Ignition Temperature (°C)/(°F)	600/1112	N/A
Peak Heat Release Rate (kW/m ²)	1509	175
Total heat release (MJ/m ²)	207	24

* Standard materials as used in cooling tower products without fire retardant modifiers

Table 1

The Limiting Oxygen Index (LOI), which represents the minimum oxygen concentration that is required to sustain a flame on the material, is going to be explained in the following sections, however, a



Prioritizing Performance

Performance testing is at the core of our research and development. We know that rigorous testing yields an optimized product, so our manufacturing process does not begin until the design has been perfected. This allows us to provide products that maximize your tower's performance while extending the lifespan of your installation.

 **BRENTWOOD®**

www.brentwoodindustries.com

+1.610.236.1100

brief overview of this test will be useful here. The LOI test places a material sample into a controlled chamber where the amount of oxygen can be regulated. From earlier, oxygen is one of the three components needed for combustion. The test then places a flame to the test sample, which is located within the oxygen controlled chamber. The concentration percentage of oxygen is raised and lowered within the chamber until the specimen remains lit for a specified time or burn distance. The lowest required oxygen percentage within the chamber for the specimen to maintain combustion is the recorded LOI. A quick look at Table 1 shows a much higher LOI of PVC which implies that PVC is more difficult to sustain a flame under normal atmospheric conditions, which has an oxygen content of 21%. The peak heat release rate and total heat release of PP is about 8-9 times of those of PVC which means that PP is more susceptible to sustaining a fire and that it releases much more heat in the combustion process which is important when you are looking at an enclosed environment like a cooling tower where that heat is contained and may accumulate. All of these characteristics indicate that PP is a much more combustible material than PVC; however, the ignition temperature of PVC is slightly lower than that of PP which is due to the poor thermal stability of PVC. But, when we look at the leading sources of ignition we see that the temperature difference is not a significant difference. Pure PVC will start thermal degradation when the temperature is raised above 150°C and will release hydrogen chloride and partially flammable gases. However, rigid PVC is considered to be a self-extinguishing material due to the substantially lower heat release rate which is insufficient to sustain the combustion reaction. The detailed combustion processes of PP and PVC are illustrated in the following section.

2.1 Combustion Of PP

Pure PP burns fast without any smoke or char residue, like other hydrocarbon which are used as fuel. This is due to the wholly aliphatic carbon-hydrogen structure. The heat of combustion of PP is reported to be around 45.8 kJ/g^[3]. The self-ignition temperature is around 600°C^[4] (1115°F).

As described in the previous section, three components are required to ignite the fire on the polymer: fuel (gas), oxygen, and heat. The dominating mechanism of pyrolysis of PP is initial chain scissions at random locations that generates C₂ to C₉₀ saturated and unsaturated hydrocarbon products, which is similar to other polyolefin products. Researchers have investigated utilizing this pyrolysis behavior to produce clean hydrocarbon fuels^[5] and lubricants^[6] from post-consumer PP products.

The combustion process of low molecular weight hydrocarbon products is a free radical, exothermic chain reaction. The decomposition of PP initiates when the temperature rises to around 320-400°C (610-750°F). At high temperatures with sufficient heat, hydrogen with one electron is extracted from the aliphatic group of hydrocarbon decomposition products of PP and generates a hydrogen free radical (H•) and a carbon free radical in the hydrocarbon gas (R•) as shown in Equation (1):



The hydrogen radicals are reactive and will react with oxygen in

the environment and generate hydroxyl radicals as shown in the followed equation:

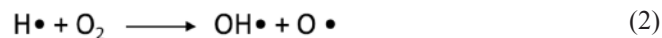

The hydroxyl will react with carbon oxygen and generate hydrogen radicals and heat that can sustain the chain reaction:

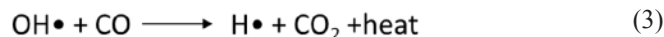

When the amount of the generated heat increases the combustion process will accelerate. On the other hand, the combustion will slow down and end when the heat is decreased^[7].

2.2 Flame retardant additives for PP

The flame resistant properties of PP can be improved by adding different types of flame retardant additives. The first flame retardant recipe for PP was patented by Blatz et al. in 1964^[8]. It was a PP compound with an organic halogen additive (1,2-dibromo-4-(α , β - di) - bromoethylcyclohexane) and antimony oxide. A successful flame retardant recipe package should satisfy the following features:

1. The flame retardant additives should either eliminate or separate one of the three components – fuel, oxygen, or heat – from the combustion reaction.
2. The additives should be stable under the regular processing conditions of PP.
3. The additives should be compatible with PP without any obvious phase separation.
4. The additives should not significantly alter the mechanical performance and other related properties of the product.

2.3 Halogenated flame retardant additives

Most of the halogen flame retardants are chemicals that contain chlorine and bromine. From the view of chemical function, iodine containing chemicals could be used as flame retardant additives as well. However, most iodine chemicals are too expensive, and they are not stable at high temperatures due to the weak chemical bonding between the carbon and iodine atoms. Powdered poly (tetrafluoroethylene) (Teflon) was typically used, in flame retardant formulation, as an additive to prevent dripping of the melted plastic.

The function of halogenated flame retardants is to perform like free radical scavengers. The halogenated chemicals will pyrolyze at high temperature and generate halogen free radicals. The halogen free radical reacts with the hydrogen carbon compounds in the gas phase and generate hydrogen halide and a free radical, which is much less active than the hydrogen radical. Due to the reaction with the hydrogen radical and hydroxyl radical, the combustion process is interfered with by the generated hydrogen halide. The reactions are illustrated by the following equations, where X is the halogen atom:



A History Built on Excellence



At HUDSON, we understand there is more to the design and production of fan blades than patented technology. We understand that there is more than establishing the highest standards in a manufacturing process, and we understand that there is more than providing the highest quality products and services to our clients – we understand that Hudson has a history.

A history developed over many years of producing the finest fan blades in the industry. We once again raise the standard with the introduction of the latest member of our famous Tuf-Lite® lineage.

With a history of fan blade production since 1955, Hudson continues to push the limits of axial flow fan technology.

For more information on this or any other product, please contact:

HUDSON PRODUCTS CORPORATION

9660 Grunwald Road, Beasley, Texas 77417-8600

Phone: (281) 396-8300

Fax: (281) 396-8388

1-800-634-9160 (24 Hours)

E-Mail: HUDSONPRODUCTS@HUDSONPRODUCTS.COM

Tuf-Lite III™

- HUDSON's Highest efficiency blade to date
- Developed from the most severe strength testing program to date
- One piece FRP construction
- Leading and trailing edge protection
- Superior "UV" protection
- Individually balanced, interchangeable blades
- Installs in current Hudson hub design
- Size ranges from 11 ft. to 33 ft. in diameter



HUDSON

Products Corporation

A Subsidiary of Hudson Products Holdings, Inc.

www.hudsonproducts.com



The halogen radical reacts with the hydrocarbon in gas phase to repeat the cycle [9]. This chain reaction eliminates the active hydrogen and hydroxyl radical from the system and impedes their heat release combustion reaction with oxygen and carbon oxygen.

Commonly used halogenated flame retardants for PP includes Bredecobromodiphenyl oxide (decobromo), decebromodiphenyl ethane (EBPB), Tetrabromobiphenyl A (TBBA), terabromobisphenol A bis (2,3-dibromopropyl ether), hexabromocyclododecane, ethylenebis (tetrabromophthalimide), tetradecabromodephenoxybenzene, pentabromobenzyl acrylate monomer, and poly (pentabromobenzyl) acrylate. The halogen content of these additives varies from 50% to 83% in weight. This high content of halogen effectively eliminates the active radical in the reaction, thus reducing the heat release.

Antimony trioxide (Sb_2O_3) is a widely used synergist of halogenated flame retardant additives for polyolefins. The typical loading of antimony trioxide is around 3%-6% of plastic weight. It must be noted that antimony trioxide does not have any flame retardant effect alone. When added with halogenated flame retardant additives, antimony trioxide reacts with hydrogen halides (HX) and generates antimony oxyhalide and antimony trihalide. Both of these products function as radical scavengers with HX to eliminate the hydrogen radical and hydroxyl radicals from the combustion process [10] as shown in the following equations:

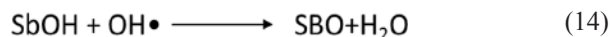
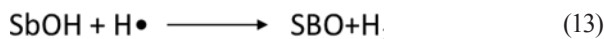
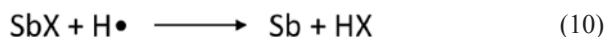
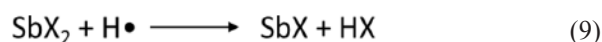
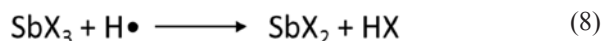

2.4 Flame Retardant Additives

Aluminum trihydroxide (ATH) is a white powder with density of 2.42 g/cm³. When heated up to 350°C ATH starts to thermally decompose into aluminum oxide and water as shown in the following equation:

The water vapor dilutes the active hydrogen and hydroxyl radicals in the combustion front and consumes the heat during the endothermic reaction [11].

The typical loading of ATH to achieve acceptable flame retardant properties is around 50-70% of the weight of the plastic. That level of loading will affect the processability of PP and has a significant negative effect on the impact property [12]. A surface treatment of stearic acid or aminosilane to ATH would improve the miscibility between ATH and polymers.

Magnesium dihydroxide (MDH) performs in a similar mechanism to ATH. However MDH starts to decompose when the temperature rises to 250°C, which is within the standard processing temperature range of PP. For that reason MDH is much less used in flame retardant additives for PP than ATH.

2.5 Phosphorus Additives

Phosphorus compounds are more widely used as flame retardant additives for oxygen-containing plastics due to their char forming properties. Phosphorus compound additives thermally decompose into phosphoric acids and form carbonaceous chars in the combustion process. This reaction is accelerated by the water which is generated during the combustion of oxygen-containing polymers, such as polyester, polyamides, and polyurethane. Since there is little char formed during the combustion of PP, when being used as a flame additive alone, the phosphorus compounds do not perform as effectively as they perform in oxygen-containing polymers.

Ethylenediamine phosphate (EDAP) is a phosphate salt that is commonly used as a flame retardant additive for PP. Unlike many other phosphorus flame retardant additives, it is a self-intumescent and does not require any other synergist to help form char [13]. The typical loading is around 30-40% of the plastic weight to achieve a UL94 V-0 classification.

2.6 Combustion of PVC

Referring to Table 1, the LOI of PVC is around 45, whereas the LOI of PP is only 17 [14], which means that PP material will burn under conditions with much less oxygen and will ignite with 1/3 less oxygen than PVC. It is believed that the lower flammability is due to multiple mechanisms. First, the pyrolysis of pure PVC generates hydrogen chloride as one of the main products. Hydrogen chloride performs as a radical scavenger as described in equation (6) and (7). Second, the mechanism of pyrolysis is believed to be a “chain unzipping” process, which is different from the chain scission process of PP. It is believed that PVC with its regular perfect structure is more stable than many other commercial polymer materials, like PP. Meanwhile, Starnes et al. [15, 16] published extensive research literature reviews and believe that the thermal decomposition of PVC is due to irregularities in PVC, such as the tertiary chlorides at the end of the branches and internal allylic chlorides. The polyenes that are generated in the “chain unzipping” process will crosslink in a secondary Diels-Alder reaction as shown in the following equation [17]:

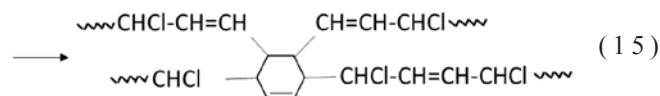

The crosslinking structures provide a negative influence in feeding of the fuel, which consists of hydrogen carbon fragments, to sustain the flame. It is reported [18] that after 90% of the dihydrochlorination, the char mainly consists of disubstituted phenyls on average. Thermalgravimetric analysis (TGA) suggests that non-plasticized PVC generates up to 17% of carbonaceous char during decomposition in air.

Benzene is also a major product of polyenes' secondary degradation as shown in the following equation. The generation of benzene is accelerated in an environment with hydrogen chloride as a catalyst. Benzene and other derived aromatic compounds are still flammable during the combustion process. The benzene and aromatic compounds are a significant source of smoke due to their tendency to condense in the gas phase [16].

Moore Sets The Standard In Axial Flow Fans.

Since 1940, Moore Fans has provided customers with high-efficiency, high-quality Axial Flow Fans for industrial applications worldwide. Operating in air-cooled heat exchangers, cooling towers, and radiators, Moore fans keep liquids cool in refineries, power plants, process plants, gas compressors and limitless other industrial settings.

Class 10000 Defines Efficiency.

Special Design Features Of The Class 10000 Fan

- Resilient Blade Mounting – For more than half a century, all Moore fan blades have been designed with a resilient blade mount, virtually eliminating all moment forces on the hub and shaft; improves durability; ideal under extreme operating conditions.
- Chord Width – Improve performance with fewer number blades for the same performance requirements, resulting in a lower overall cost.
- Blade Angle Adjustment – Blades are factory preset for specified performance conditions eliminating the need to set during field installation.
- Ring Depth – Designed to operate in a reduced fan ring depth.
- Adjustable Diameter – Designed to permit fan diameter adjustment by as much as +/-1.5 inches (3.81 cm), greatly easing installation.
- Ideal For Variable Speed – With Moore's resilient mount system, there are virtually no critical speeds to be avoided.
- Available Blades – Available in both odd and even number of blades, up to 16.
- Low Noise – Where noise levels are critical, combine Vortex tips, wider chord width and increased number of blades for maximum noise reduction.
- Strengthened Design – For engine drive and larger fan diameter applications from four to 24 feet.

Today, Moore Fans has some 175,000 fans in operation around the world. And with sales offices in North America and in Europe, Moore factory engineers and customer service representatives stand ready to help you analyze your air moving requirements, choose the right product, and provide reliable service and support, before and after the sale.

For more information on the Class 10000 Fans or any of the family of quality products from Moore Fans call **660-376-3575** or visit us online at **moorefans.com**.



Latest Resilient Mount design developed through 50 years of operating experience.



Moore
FANS

MOORE FANS LLC, MAIN SALES OFFICE & FACTORY
800 South Missouri Avenue, Marceline, MO 64658 USA
Phone: 660-376-3575 • Fax: 660-376-2909
E-mail: info@moorefans.com

MOORE FANS LTD, EUROPEAN SALES OFFICE
44 Cooden Sea Road • Bexhill-on-Sea
East Sussex • TN39 4SL • UK
Tel: +44 1424 845725 • Fax: +44 1424 848780
E-mail: mail@moorefans.eu.com

INDUSTRIAL AIR MOVING EQUIPMENT

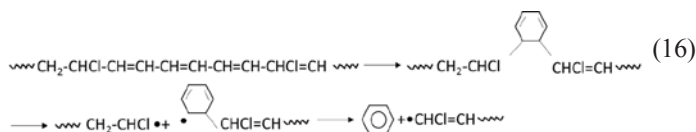

2.7 Flame retardant additives for PVC

There has been a long history of antimony trioxide being used as flame retardant additive for PVC. Similar to PP, and as an additive for PVC, antimony trioxide performs as more of a synergist rather than as a flame retardant itself. It has been shown that the LOI of PVC increased linearly with an increased loading of antimony trioxide [19]. However the char formation was not significantly affected by the loading of antimony trioxide.

The LOI of PVC is around 45 which is much higher than most polymer materials. However, the flammability of PVC products is affected by the loading of plasticizers, which are an excellent fuel for the combustion process. Chlorinated paraffin has been widely used as a secondary plasticizer for PVC. Chlorinated paraffin does not offer further flame retardant properties to PVC matrix. However, given the fact that most of the primary plasticizers are flammable, chloroparaffin helps to reduce their flammability and increases the concentration of halogen in the material. Due to some drawbacks of chloroparaffins, such as lower thermal stability, low viscosity, and toxicity concerns, the applications of chloroparaffins are limited.

Phosphate esters are often used as plasticizers of PVC to sustain the flame retardant properties. A rule of thumb is that along with non-flame retardant plasticizer, around 20% of phosphate esters plasticizers are required to have the PVC material sustain the self-extinguishing properties [20]. Besides flammability, phosphate additives also affect other properties such as heat stability, flexibility in low temperature, and aging. Triaryl phosphate presents good thermal stabilities but decreases the flexibility in low temperatures due to its rigid aromatic group. Trialkyl phosphates can provide much better flexibility in low temperature, however it should be noted that compared to neat solid PVC, phosphate plasticizers still provide a negative effect on the LOI level due to its richer fuel content.

Mineral fillers, including ATH and MDH, are also widely used to improve the flame retardant properties of PVC product. Similarly to their use in PP both ATH and MDH perform as effective flame retardant additives by diluting the combustible pyrolysis products, releasing water, and providing solid inorganic residues (char) in the condensed phase. ATH is often used with zinc borate (ZB), which acts as a synergist partially substituted for antimony trioxide, to improve the flame retardancy of PVC. It has been reported that a relatively lower loading of ATH/ZB mixture compounding in PVC would effectively promote char forming and eliminate the release of combustible aromatics, such as benzene and toluene [21].

3.0 Characterization Approaches For Flammability Of Polymer Materials

Now that we have an understanding of how polymers burn and how some additives may affect the combustibility of those polymers, we can look at the different tests available to analyze the flammability of polymer materials and see if these tests are a good indicator of the potential fire risk of a fill in a cooling tower.

The flammability of materials can be characterized from different aspects, including ignitability, extinguishment, rate of flame spread, rate of heat release, fire distinguishable features, and smoke. The choice of testing approaches should depend on the application of

the product. The sample size of different flammability test methods varies from very small size (inches/centimeters) to full size (feet/meters). However all of the test methods that we will be looking at limit the characterization of flammability of a material only in a certain scenario and are not able to be utilized to predict the behavior in a real fire situation as it would occur in the real world. However, a combination of tests might provide a better picture than what the industry uses today.

3.1 Limiting Oxygen Index (LOI)

Limiting oxygen index is a small scale test approach that is widely used in both industry and research and development to characterize the flammability of polymer material. It uses the minimum concentration of oxygen that is required to support the combustion process under a certain environment, which is defined in the test, to indicate the relative flammability of the polymer material. In the LOI test the specimen is placed in a chamber and ignited from the top. If the specimen cannot be ignited or it extinguishes in 30 seconds, then the test increases the concentration of the oxygen. When the flame on the specimen lasts more than 3 minutes or more than 5cm of specimen was burned after the ignition source was removed, then the test decreases the concentration of oxygen. The limiting oxygen index value is determined as the highest concentration level of oxygen where the fire extinguished in less than 3 minutes and 5cm of specimen was burned [22]. As described here, LOI doesn't characterize any real fire scenario, however, the LOI result is quite repeatable and able to differentiate the flammability of material in a numerical manner. The plastics industry agrees that a polymer with an LOI of 27 or more is considered to be a flame retardant material, the higher above 27 the more flame retardant the material is. Why is this? Atmospheric air contains 21% oxygen and the 6 point difference leaves enough percentage between standard air and the polymers LOI that the polymer would be considered more difficult to ignite under standard atmospheric conditions. This approach is included in national and international standards such as ASTM D2863-97, BS ISO 4589-2, and NES 714. Besides the limiting oxygen index, the device can be used to characterize the char forming rate as well [23]. For a cooling tower application this will provide an indicator of how easily the cooling tower fill material will remain on fire at the beginning stages of a fire event or if it will ignite at all. This test is a good indicator of a fill materials risk of starting, and sustaining, a fire within a cooling tower. However, this test is for the material only and does not take into account fill geometries and a fill product's fire potential, which can become much more complicated. However, a fill material's LOI number can provide an owner a numerical number to analyze in order to assess risk potential. The higher above 27 the less risk for a fire to start and be sustained while a fill with an LOI closer to 27, and even below, poses a much higher risk and ease of ignition.

3.2 Cone Calorimeter

A cone calorimeter can measure the heat and smoke release rate of the material under a wide range of radiant heat exposure. In a cone calorimeter test the sample plaque is placed on top of a load cell with a heat flux from a cone radiant heater. The heat flux can be adjusted to perform different levels of fire. The specimen is ignited by an electric spark source. According to Huggett's principle [24], the heat release rate can be calculated from the amount of oxygen that is consumed by the combustion process. The combustion parameters that can be provided by the cone calorimeter test include: time to ignition, heat release rate (HRR), peak heat release rate (PHRR), total heat release (THR), mass loss rate (MLR), and specific extinction area (SEA). The horizontal burning in the cone calorimeter test may not be an appropriate approach to character-



KIMCO, The Altimate in environmental-friendly Cooling Tower!

KIMCO serves all kinds of cooling towers with numerous new options. Enjoy the benefits!



- PLUME ABATEMENT DESIGN
- SUPER LOW NOISE DESIGN
- ANTI-BACTERIA, LEGIO-FREE TOWER
- HIGH EFFICIENCY, ENERGY SAVING DESIGN
- NON-CORROSION FRP STRUCTURE CONSTRUCTION
- CTI CERTIFIED MODELS ARE AVAILABLE :
DYNA-COOL / CKL / ENDURA-COOL



MODULAR TYPE, FRP TOWER



COUNTER FLOW
FRP TOWER



FIELD ERECTED, COUNTER
FLOW, PLUME ABATEMENT,
CONCRETE TOWER



FIELD ERECTED, COUNTER
FLOW, STEEL TOWER

COOLING TOWER
KIMCO
www.kimcoct.com

FOR MORE INFORMATION, CONTACT
E-mail : kimco@kimcoct.com



ISO 9001
ISO 14001



MEMBER



93-18-01
05-18-02
09-18-03

ize the vertical bottom-up burning behavior of cooling tower fill media as it is installed in a cooling tower. The cone calorimeter test is included in the national and international standards of ASTM E1354, ISO 5660-1, and ASTM D6113. For a cooling tower application this test can provide some very insightful information. The HRR, PHRR and THR should be considered when looking at the potential fire risk of a fill media because, if the media begins to burn, the heat generated may play a significant part in the overall damage to other components in the tower and adjacent structures or machinery as well as the material's ability to support the combustion cycle within itself. Higher heat can lead to increased risk of other cooling tower components, including structures, lubricants and piping to more readily catch fire. The risk of high heat release should be considered as it pertains to not just the cooling tower but also the potential for ignition or destruction of surrounding buildings and objects. Therefore a lower HRR, PHRR and THR equates to a lower overall risk potential for the fill media for the cooling tower owner. Note that, this analysis is based upon the fill media igniting in the first place, which supports that the LOI of a fill media should be weighed more heavily when considering the overall fire risk potential.

3.3 UL94 Flammability Test

The UL94 test is designed to characterize the response of polymer materials to an existing fire source. In the UL94 test, a Bunsen burner flame with a height of 19mm (fed with methane) is applied twice to the specimen, 10 seconds each time. A wad of surgical cotton is placed 300mm below the specimen to detect the flammability of the dripping. Five specimens are tested in both horizontal and vertical tests. Different rating categories are applied according to the burning behavior of the sample which is also performed and rated according to the material thickness:

- HB: All five specimens self-extinguish before the 25mm mark or burn in a rate less than 75mm/min with a sample thickness less than 3mm (or <40 mm/min with a thickness between 3-13mm)
- V0: All five specimens extinguish in less than 10 seconds after the flame is removed, and the cotton is not ignited by the dripping.
- V1: All five specimens extinguish in less than 30 seconds after the flame is removed, and the cotton is not ignited by the dripping.
- V2: All five specimens extinguish in less than 30 seconds after the flame is removed, and the cotton is ignited by the dripping.
- 5VA: The flame is applied to the bar specimen five times for a duration of five seconds each. All five bar specimens extinguish in less than 60 seconds. The cotton was not ignited by the dripping. The plaque specimens are burned through.
- 5VB: All five bar specimens extinguish in less than 60 seconds. The cotton is not ignited by the dripping. The specimens are not burned through.

The UL94 test is a widely accepted test approach to evaluate a polymer material's flammability. The national and international standards of UL94 test include: ASTM D3801, IEC 60695-11-10, IEC60707, and ISO 1210.

When considering polymers used in cooling tower fill media and how they rate in a UL94 test, we would expect to see all products fall into a V0 or better rating. A V0 rating would tend to indicate that the polymer fill material poses less risk to sustain a fire event and drip, which could increase the risk of spreading the fire. Again,

this test is for a material only and not necessarily a reflection of a product.

While discussing material testing we should mention that along with UL94, the ASTM D635 is a very similar test in that it applies a flame from a Bunsen Burner for a specified time to a sample and measures the time or distance that the flame propagates, however, it differs in that it orients the test sample horizontally rather than vertically within the test chamber. This test report's provides a numerical rate of linear burning number for a specimen.

3.4 Steiner Tunnel Test (ASTM E-84)

The Steiner Tunnel Test, more familiarly known as an ASTM E84 Test, is a large scale flame test that is mainly used for building construction materials in the United States, particularly for wall and ceiling coverings and treatments, but the cooling tower industry has borrowed this test for its products. The size of the tunnel is 7.62 x 0.46 x 0.30m (25 x 1.5 x 1ft). There are windows on the tunnel walls to observe the propagation of the flame. The sample product with dimensions of 7.32m long and 0.51m (24ft x 1.67ft) wide is mounted on the ceiling of the tunnel, without regard to how the product is placed in a real application such as a cooling tower. The testing standard does not determine the size, thickness or orientation of the test material to reflect how the material will be applied in the marketplace so this leaves much variability and possibility for unrealistic or subjective results. The test also does not address what rating to give for materials that may drip, melt or delaminate during the test. Materials such as Polypropylene or Polyethylene have shown that during this test they melt and drip to the floor of the testing tunnel rather than remain in position. It should be noted that this test may not be applicable to these types of product materials because of the inability for the test specimen to remain in place for the full testing period. A gas burner is applied to the product at the end of the tunnel for 10 minutes. A forced draft is applied through the tunnel from the end of the burner with an air velocity of 1.22m/s (240ft/min). The maximum extent of the flame spread is observed through the windows on the tunnel. The flame spread index is calculated with respect to two base values: fiber cement board is assigned a 0 and red oak flooring is assigned a 100. The smoke developed index is calculated in a similar approach. The Steiner Tunnel Test is included in ASTM E84. It is important to note how the results of the ASTM E84 test are presented and what they do and do not mean. The cooling tower industry, through CTI, has determined correctly that there is no distinguishable difference between materials that test below an FSI of 25. Due to the variability in the testing and its subjective nature, the lowest FSI rating given is 25 or less, so any material listed with a 25 or less number has the same E84 classification and should be considered having the same level of flame spread. Due to the subjective nature and variability, there are numerous tests where the same sample can give results from an FSI of 5 to an FSI of 20, or even greater variability as much depends upon how the test samples are selected and arranged within the test chamber.

The cooling tower industry has ceded that the standard E84 test needs further clarifications to its testing protocol in order to test cooling tower products. Due to the lack of definition on sample preparation CTI has developed guideline recommendations as to how a cooling tower product sample should be oriented, configured and placed within the testing tunnel for an E84 test, see Cooling Technology Institute (CTI) Standard 136 (2010). Engineering specifications for cooling towers do not always call out that the E84 test should be performed in accordance to the recommendations in CTI STD-136 (2010) which leaves great variation in possible testing outcomes and the potential for the use of old ratings that

COOLING TOWER



PROTECTION



No Special Training Needed



Easy To Apply By Hand



Non-Toxic & No VOC's

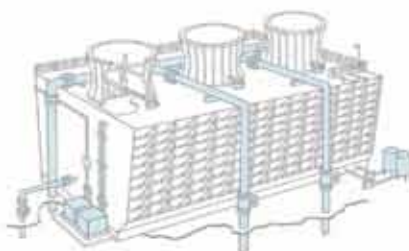

Wet/dry cycles and constant temperature changes can create expensive corrosion damage to cooling towers. Denso's Petrolatum Tape Systems provides protection for piping, conduit, electrical boxes, hangers, valves, flanges and sprinkler systems with minimum surface preparation required.



For More Information

Call: 281-821-3355

Fax: 281-821-0304

E-mail: info@densona.com

www.densona.com

were performed prior to the 2010 recommendations by CTI, which may not be acceptable according to current recommendations and standards.

This type of test provides good information to an owner as to how fast a fire will spread within a product, but not necessarily how it will act inside of an actual cooling tower, as the test samples are not tested as they would be fully installed within a cooling tower. The benefit of adopting this type of test for the cooling tower industry is that, if products are tested according to CTI STD-136, then a result of 25 or less reduces the chances of a cooling tower fill to be grossly flammable and will provide more validity to the testing outcomes because the fill samples will all be set up and tested in the same configuration. It would be recommended to have an independent agency that is familiar with cooling tower products, such as CTI, oversee the set-up and sample configuration for the ASTM E84 testing for uniformity in sample preparation, and therefore, testing results within the industry.

3.5 Factory Mutual Test 4930 (FM4930)

The FM4930 test for cooling towers involves wind, seismic and fire parameters. This paper will address the fire section solely. FM Global is a mutual insurance agency specializing in loss prevention and is regarded as the company that sets the standard for product testing and gauging operational risk potential for equipment within facilities. FM4930 is a full scale test for a cooling tower that is designed to determine if a certain method of construction and materials can contain a fire event, or limit a fire event, so that the owner may be able to retain 75% of their design capability after such a fire event. Each participating cooling tower manufacturer or designer is required to build a full scale product as it would be for an installed application, then a pan containing a measured amount of heptane fuel is placed on the underside of the cooling tower fill media and ignited. This provides a constant, timed, fuel source to purposefully ignite the cooling tower fill media in order to determine if the cooling tower design can contain, or mitigate, the fire to the above-mentioned standard.

The benefit of this test is that an owner can have confidence that should a fire start in one of their cooling tower cells, the FM approved tower design should still allow the owner to have 75% of the capability remaining after that fire event. However, is this test a good indicator of a real world risk? As of the writing of this paper there can be no instances found where a sustained fire source was accidentally created from below the cooling tower fill media as the cause of a cooling tower fire event. The outcome of this test requires that a sustained fire source be present and applied to the underside of the fill media in order to purposefully ignite the cooling tower. The FM4930 test does not provide an owner a good indicator of risk for a cooling tower fill media's potential for ignition or sustaining a fire based on how the vast majority of cooling tower fires are started, which would be from above the fill pack. This test provides owners a good idea of how a cooling tower may contain a fire event after combustion is initiated, sustained and propagated but does not provide any indication as to the tower's risk potential of a fire event to actually begin and be sustained without a sustained source of heat. Where this test provides owners with a high level of certainty that their cooling tower will be able to contain a fire, it does not address the question of what the tower's risk potential is for a fire to start in the first place.

4.0 Conclusion

It should be noted that all of the listed test approaches have successfully proven the characterization of flammability of polymer materials or products. However, there is no clear relationship

reported between the test results of any of these test approaches. The LOI test uses the concentration of oxygen to characterize the flammability of the material. The cone calorimeter test focuses on the heat release during the combustion process. UL94 and the Steiner Tunnel Test simply represent the response of a material/product in a laboratory fire situation.

Weil et al. found rather disappointing correlations between test results from cone calorimeter and LOI tests [25]. Morgan, A. et al. investigated 18 thermoplastic materials with UL94 ratings from HB to V0 [26], and they found a very rough correlation between peak heat release rate (PHRR) and heat release rate (HRR) at 60 seconds, however, no correlation with time to ignition or total release rate.

Now that we know what polymer combustion is, what factors can affect it and what tests are currently available or being used in the cooling tower industry, can the cooling tower industry provide an owner or end user a test that will help them be able to gauge whether a potential cooling tower purchase has a high or low potential to have a fire event? Based on the above information, the answer would need to be "no". However, is there a group of current tests that could be used in conjunction with one another to get a very good indication, and improve upon the methods used today, of a cooling tower fill media's fire potential risk? The answer to that question looks to be "yes". Based upon the above information, the use of an LOI test in conjunction with the E84 test, which must be tested in accordance with CTI Standard 136 (2010), would provide for a more clear risk picture than what the industry is currently utilizing, especially overstating E84 without mention of CTI recommendations. Based upon this research and material testing, the recommendation for an owner wanting a lower risk fill media in their tower would be to have a material with an LOI of 40 or above in order to reduce the probability of the media to catch fire and to sustain that fire, as well as a product Flame Spread Rating of 25 or less, so that if there is an external fire source, the fire will spread as slowly as possible. The numerical results for both the E84 test and LOI can be easily provided for a product by the manufacturer and the LOI can readily be determined by the owner to confirm conformity to desired LOI, just like any other material conformity test. These two tests can provide a numerical comparison for a fill material and product and if an owner wishes to look a little deeper into risk factors the UL94, or ASTM D635, test and the cone calorimeter tests, specifically peak heat release rate (PHRR) and total heat release (THR), can provide further insight as part of the combustion process of fuel, heat and oxygen. In that case, a chart like the one listed below in Table 2, may be utilized as a reference to gauge a cooling tower fill media's fire risk potential. Note that the below chart does not take into consideration a fill media's sheet thickness or overall geometry which will play some role in the fill media's fire risk potential, but has not been included in the scope of this paper.

Test	Potential Fire Risk	
	Higher risk	Lower Risk
ASTM E84 (CTI STD-136(2010))	≤ 25 FSI	≥ 25 FSI
LOI / ASTM D2863	≥ 40	≤ 27
UL94/ASTM D635 (1/16" sample)	V0	V1, V2
Peak Heat Release Rate (kW/m ²)	≤ 500	≥ 800
Total Heat Release (MJ/m ²)	≤ 75	≥ 125

Table 2

1. Takashi Kashiwagi, "Polymer Combustion and Flammability – Role of the Condensed Phase", 25th symposium on Combustion/ The combustion Institute 1994, 1423-1437.
2. D. A. Dalzell, R. J. Nulph, Proc. Soc. Plast. Eng., 28th, ANTEC 1970, 215.
3. Weil, Edward D.; Levchik, Sergei V. "Flame Retardants for Plastics and Textiles - Practical Applications", Hanser Publishers, 2009.
4. Practical Guide to PP.
5. Ballice L, Reimerta R. "Classification of volatile products from the temperature-programmed pyrolysis of PP (PP), atactic-PP (APP_ and thermogravimetrically derived kinetics of pyrolysis", Chem Engng Process 2002; 41; 289-296.
6. Ding W, ling J, Anderson LL. "Thermal and catalytic degradation of high-density polyethylene and commingled post-consumer plastic waste" Fuel Process Technol 1997 ; 41 47.
7. Christy, M. R., "Standards, Bans, and Flame Retardants", Plastics Compounding, trade journal – Advanstar Communications, Inc., 1993.
8. Blatz PS. French Patent 1964; 1, 355,064. Cited in: Lyons JW. The chemistry and uses of fire retardants, Wiley-Interscience, New York, London, Sysdney, Toronto; 1970.
9. Troitzh, H. J., "Flame Retardants" Plastics Additives, reference book (ISBN 3-446-17571-7), Carl Hanser Verlag, 1996.
10. I. Touval, Antimony and other inorganic flame retardants, Kirk-Othmer Encyclopedia of Chemical Technology, fourth ed., vol. 10, John Wiley & Sons, NY, pp.936 e954.
11. D. Price, F. Gao, G. J. Milnes, E. B., C. I. Lindsay, and P. T. McGrail, Laser pyrolysis/time-of-flight mass spectrometry studies pertinent to the behaviour of fame-retarded polymers in real fire situations. Polymer Degradation and Stability, 64 (1999),403–10.
12. U. Hippi, J. Mattila, M. Korhonen, and J. Seppala, Compatibilization of polyethylene/aluminum hydroxide (PE/ATH) and polyethylene/magnesium hydrox-ide (PE/MH) composites with functionalized polyethylenes. Polymer, 74 (2003),1193–1201..
13. Goin, C.L., Huggard, M.T., Paper presented at 2rd Annual BCC Conference on Recent Advances in Flame Retardancy of Polymeric Materials, Stamford, CT,May (1991).
14. Nicholson, John W. "Chemistry of polymers (3rd edition)" Royal Society of Chemistry, 2006.
15. Starnes W.H. Jr, Girois S. polymer yearbook, 1995; 12:105.
16. Starnes W.H. Jr, "Structural and mechanistic aspects of the thermal degradation of poly(vinyl chloride)" Progress in polymer science 27 (2002) 2133-2170.
17. Sergel V. Levchik, Edward D. Wel " Overview of the recent literature on flame retardancy and smoke suppression in PVC" Polymers for Advanced Technologies 2005, 16, 707-716.
18. Dick CM, Snape CE, Liggard JJ. Polym. Mater., sci. eng. 2000, 84, 185.
19. Wang, H; Wang, H; Guo, Z.; Qi, S.; Tian, C.; J. Fire Science 24, 3, 195-210, 2006.
20. O'Mara M.M, Ward W, Knechtges DP, Meyer RJ. In Flame Retardant Polymeric Materials, Vol 1, Kuryla WC, Papa AJ. Marcel Dekker: New York, 1973 193-273.
21. Ning Y, Guo S. J. Appl. Polym. Sci. 2000,77 3119.
22. ASTM D2653
23. Zhu,W,Weil,E.D., J. Appl. Polym. Sci. (1998) 67, pp. 1405–1414.
24. Huggett, C., Fire and Materials. 4(2), 61-65, (1980) [2] "Ten Years of Heat Release Research with the Cone Calorimeter." Ten Years of Heat Release Research with the Cone Calorimeter. N.p., n.d. Web. 03 Mar. 2013. [3] Newth, Alex, and Angela B. Wise Geek. Conjecture, 2nd. Web. 03 Mar. 2013.
25. Weil ED, Hirschler MM, Patel NG, Said MM, Shakir S. Oxygen index: correlations to other fire tests. Fire and Materials 1992; 16:159–167.
26. Morgan, A., Paper presented at 17th Annual BCC Conference on Recent Advances in Flame Retardancy of Polymeric Materials, Stamford, CT, May (2006).PAPER NO: TP15-13

Looking To Strike Out On Your Own?



QualiChem can help you make the leap to owning your own water treatment business.

We understand your needs and will provide expert support every step of the way:

- **World-class manufacturing and custom formulations**
- **Private labeling**
- **Unparalleled technical support**
- **Business planning and sales development strategies**

Contact us to learn more on how we can help your business grow.

540.444.5819

watertreatment@qualichem.com



www.qualichem.com

QUALICHEM
Water Treatment

An ISO 9001: 2008 Company

Alternative to Bromine Improves Cooling Water Microbial Control and Overall Treatment

Andrew Boal, PhD, MIOX Corporation

Abstract

Ammonia in the cooling loop poses an additional challenge for hypochlorite or oxidizing biocides in controlling the microbiological activity since chloramines are typically seen as less effective biocides as compared to free chlorine. Often, cooling tower biocidal treatment is accomplished with bromine based non-oxidizing biocides coupled with the occasional application of isothiazolin or gluteraldehyde. This paper demonstrated that Mixed Oxidant Solution (MOS), a biocide produced through the electrolysis of sodium chloride brines, is a highly effective biocide. Without overcoming ammonia, and in high pH environments, MOS was able to successfully control the microbial populations in the cooling tower waters of a major semiconductor facility in the US, where ammonia contaminated wastewater is used as part of the makeup water for cooling towers.

Introduction

Awareness of the broad issues surrounding the increasing scarcity of freshwater supplies, especially in the western and southwestern US, is driving many companies to find ways to increase the use lifetime of waters used in various industrial processes. This is especially true in the semiconductor manufacturing industry, where industry leaders are engaged in a number of programs aimed at minimizing freshwater consumption and increasing the amount of water reuse within manufacturing facilities. Internal reuse of process wastewaters for cooling systems is often an easy approach which can lead to the increased use of water in an industrial setting, however, proper treatment of these waters is required to ensure the reuse water does not interfere with cooling processes.

Oxidizing halogen biocides, typically aqueous chlorine or bromine, are often used as the primary biocide in cooling tower disinfection applications. Both aqueous chlorine and bromine are highly effective at inactivating bacteria responsible for forming biofilms, such as *Pseudomonas aeruginosa*, as well as bacteria responsible for causing human illness, such as *Legionella pneumophila*. Often, when the pH of the water in a cooling tower is greater than 8, bromine has traditionally considered to be the oxidizing biocide of choice. However, emerging experience indicates that Mixed Oxidant Solution (MOS), produced using on-site generation (OSG) systems (Figure 1), can be more effective than bromine as a disinfectant for cooling system waters.

Depending on the compositional makeup of the wastewater, internal wastewater reuse for cooling applications can present a number of treatment challenges to facility operators. One common wastewater stream repurposed for cooling applications in semiconductor manufacturing facilities are ammonia-laden wastewaters derived initially from ultrapure water (UPW) sources. UPW waters are beneficial for cooling system operations from the standpoint that



Andrew Boal

they will not contribute calcium or magnesium hardness to the water within the cooling system, thereby helping to minimize the formation of scale within the cooling system. However, the presence of ammonia in the water can potentially interfere with oxidizing biocides which are typically part of the overall cooling water treatment regimen.

Aqueous chlorine reacts with ammonia to produce monochloramine (NH_2Cl), dichloramine (NHCl_2), trichloramine (NCl_3), and ultimately nitrogen gas through a series of chemical reactions. Cooling tower waters typically have a pH in the range of 8–9, and in this range, the predominant chlorine species is the hypochlorite ion (ClO^-) and the predominant ammonia species is the ammonium ion (NH_4^+). Reactions

between these two components result in the production of various chloramine species:

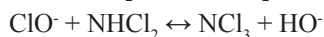
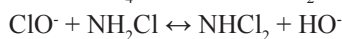
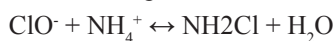

Similar reactions occur between aqueous bromine and ammonia, resulting in the production of bromamine species. Due to the complex chemistry and microbial inactivation efficacy of chloramine and bromamine produced in situ during cooling tower disinfection, the formation of these chemicals often presents a unique challenge to a cooling system operator.

Overall, use of ammonia-laden wastewaters as a source of cooling tower makeup water can provide a substantial benefit to the facility operator in terms of decreasing wastewater production as well as fresh water consumption, but also presents a substantial challenge in tailoring an appropriate biocidal treatment regimen. Biocidal treatment of these waters must account for the expected decreased biocidal treatment efficacy as well as to navigate the complex chemistries which occur in these treatment scenarios due to the presence of ammonia to both effectively removal microbial contaminants from the water and preserve worker and reputational safety.

Mixed Oxidant Solution (MOS) has been previously shown to be a highly effective biocidal treatment for cooling towers, even under the typically high pH environment often found in cooling waters. MOS has demonstrated enhanced microbial inactivation efficacy over bromine under these treatment conditions, as well as effectively treat challenging waters such as those where high levels of ammonia are present. MOS is a chlorine-based oxidant solution produced through the electrolysis of sodium chloride brines through two, distinct, electrochemical mechanisms. At the anode, chloride ions are oxidized to produce chlorine, which eventually results in the production of sodium hypochlorite with and overall chemical transformation of:

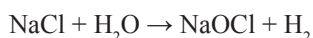



FIND IT HERE **NOW.**

GET IT THERE **FAST.**



Bedford has thousands of corrosion-resistant FRP profiles in stock, available immediately. You could place an order today, have it fabricated to your specs, and get it shipped faster than ever before. We've built up our inventory to deliver the industry's shortest lead times — so you can deliver faster for your customers.



Call 800-377-3280 or visit bedfordreinforced.com/inventory.

Simultaneously, oxygen can be reduced at the cathode to produce hydrogen peroxide according to the electrochemical transformation of:

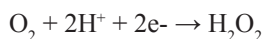

Combined, the hypochlorite and hydrogen peroxide result in a highly potent biocide with superior microbial inactivation efficacy as compared to standard hypochlorite.¹

In this paper, data from a field installation conducted at a site where ammonia containing wastewater is used as part of the make-up water for a large cooling tower system is also presented. Here, historic treatment outcome data from a bromine-based biocide treatment regimen is compared with results where MOS produced from an OSG system is used to displace the bromine and other biocidal agents. Results here will show that MOS, even when applied at a substantially lower effective dosage, was able to effectively control the microbial population in these waters.

Osg System Installation And Comparative Study Design

Working with the facility operator, an OSG system capable of producing MOS was installed at the cooling tower site in early 2014. Validation of the efficacy of MOS for the treatment of this water was accomplished by conducting an extensive study of the outcomes of the biocidal treatment during the initial weeks of the use of the OSG system at this site. This study was conducted from January to July of 2014, with the first 11 weeks of the study using the previously existing biocidal treatment regimen and the following 18 weeks utilizing only MOS as the biocide. During this time, water quality parameters (including pH, conductivity, alkalinity, corrosion, ammonia concentration, and chlorine residuals), microbial populations, and overall chemical consumption were monitored. This data then enabled an accurate comparison of MOS with the previously utilized bromine-based biocide treatment regimen in terms of both ability to control microbial populations as well as in regards to the relative operational expenses.

Biocide Treatment Programs

Prior to the installation of the MOS OSG system at the location, the microbial treatment of the cooling water focused on the use of a 4:1 chlorine/bromine oxidizing biocide, which was provided as a concentrate to the facility and slug fed into the water twice per day with a goal of having an Oxidation Reduction Potential (ORP) of ~400 mV in the cooling water. In addition to oxidizing biocide, isothiazolin, gluteraldehyde, and an algaecide were periodically slug fed into the water as needed. Biocidal treatment using MOS was accomplished by a continuous feed operation where MOS was fed into the cooling water to maintain a target maximum ORP of 275 mV in the water. No other biocides were used once the use of MOS as the oxidizing biocide was initiated. Corrosion inhibition and anti-scalant treatment chemicals and their dosage amounts were unchanged as a result of the transition to the use of MOS as the biocide.

Treatment Comparison

During this study, a number of water quality parameters, as well as the relative amount of oxidizing biocide present in the water, were observed to change as a result of the transition from a chlorine/bromine biocide to MOS (Table 1). Core water properties such as pH (Figure 2) and conductivity (Figure 3) were both observed to decrease once the use of MOS was initiated. During this study period, the average pH of the water before and after the use of MOS was found to be 8.63 and 8.57, respectively, while the average

conductivity of water before and after the transition to MOS was found to be 993 mS and 667 mS, respectively, and was likely due to the decreased oxidant dosage added to the water. Other water quality parameters, such as alkalinity and hardness, were found to be essentially unchanged during the study period.

Residual biocide concentrations were also seen to decrease after the transition to the use of MOS (Figure 4). Residual biocides were measured both as the Free Chlorine residual and Total Chlorine residual. Here, the Chlorine residuals measured the presence of both chlorine and bromine during the chlorine/bromine phase of treatment since the measurement test used does not discriminate between the two chemicals. Free Chlorine refers to either bromine or chlorine that has not reacted with ammonia to make chloramine or bromamine, while the total chlorine measurement is both the free chlorine or bromine as well as the chloramine and bromamine. As can be seen, the free chlorine residual decreased from an average of 0.27 mg/L to an average of 0.09 mg/L and the total chlorine residual decreased from an average 0.38 mg/L to an average of 0.16 mg/L after the transition to MOS. Effectively, once the MOS was used as the biocide, the water was being treated with 60% less biocide as compared to the chlorine/bromine treatment regimen. Moreover, this data also demonstrates that, under both biocidal regimens, the oxidizing biocide is mostly in the form of chloramine or bromamine.

Microbial populations within the water were found to be typically 1,000 CFU/mL both before and after the transition to the use of MOS (Figure 5). Importantly, this data validates that MOS is a highly effective biocide for the challenging water in this tower. Even under the high pH environment and in the presence of ammonia, MOS was shown to be as effective as the prior chlorine/bromine-based biocide regimen even though no additional biocides were used and the MOS was used as an effective dose rate about 60% smaller than the chlorine/bromine biocide.

Other treatment benefits were also realized as a result of the decreased biocide dose used in this tower. Corrosion analysis found that there was reduced corrosion after the transition to MOS occurred (Figure 6). Average corrosion rates for mild steel decreased from 0.5 mpy to 0.1 mpy after the transition while the average corrosion rates for copper were observed to decrease from 0.02 mpy to 0.015 mpy after the transition to MOS.

Cost Comparison

During the study timeframe, close monitoring of the chemical consumption both before and after the transition to MOS occurred allowed the site operator to assess the impact of using OSG equipment to provide the biocide component of the cooling water treatment program. With an estimated operational expense of less than \$1,000 per year, including the cost of both salt and electricity required to produce the full amount of biocide needed at this tower, the tower operator was able to realize a cost savings of \$240,000-\$280,000 per year. This cost savings translates into a highly attractive Return on Investment of less than one year for the OSG system installed at this location. Given the reduced corrosion rates observed, it is likely that the consumption of corrosion prevention chemicals could also be decreased, thus allowing for additional cost savings.

Conclusions

Results from this study clearly demonstrated that MOS is a highly effective biocide for cooling tower disinfection, even in high pH environments and in the presence of ammonia in the water. Here, it was found that an effective MOS dose that was 60% less than the chlorine/bromine disinfectant used before the implementation



Walchem Controllers give you complete control of chemical metering pumps and valves in a broad range of water treatment applications.

With easy, icon-based programming on the large touchscreen display, the W600 can be configured to control up to six complex functions. The universal sensor input permits exceptional flexibility to utilize almost any type of sensor including pH/ORP, conductivity, disinfection, fluorescence and flow meter input.

VTouch® provides quick, centralized 24/7 awareness of account status with the ability to LIVE Connect to any of your controllers in the field with one simple mouse-click. Internet connectivity enables you maintain control via remote access.

- ✓ **Powerful Programming**
- ✓ **Complete Control**
- ✓ **Online Access**
- ✓ **Easy Setup**
- ✓ **Outstanding Value**

Take control today and connect with the best!

W A L C H E M

IWAKI America Inc.

For more information: 508-429-1110 | www.walchem.com

5 Boynton Road | Hopping Brook Park | Holliston, MA 01746

of MOS was able to maintain a similar control over the microbial population in the cooling tower water. Using less biocide had the added benefit of a significant reduction in the observed corrosion rates, potentially allowing for a reduction in the use of corrosion prevention chemicals. Financially, this site is expected to achieve a cost savings of at least \$240,000-\$280,000 per year as a result of replacing the chlorine/bromine biocide with MOS, resulting in a highly attractive Return on Investment for the OSG system in place.

Acknowledgements

The Author would like to thank Drs. Susan B. Rivera and Bobban Subhadra, who designed and conducted that laboratory inactivation experiments presented in this work, as well as Mr. Steve Garcia, who managed the field installation.

Appendix: Laboratory Comparison Of Mos And Bromine

Laboratory testing was conducted to further differentiate the microbial inactivation efficacy of MOS and bromine. Studies utilized simulated cooling tower waters spiked with *P. aeruginosa* and *L. pneumophila*. Test waters were prepared to have an alkalinity of 200 mg/L as sodium bicarbonate, hardness of 400 mg/L as calcium carbonate, and pH adjusted to 8.5. After sterilization, these waters were inoculated with *P. aeruginosa* and *L. pneumophila* to at least 10,000 cfu/mL. MOS or bromine was then dosed into the waters to a Free Available Chlorine concentration (as measured using standard DPD methodology) of 0.25 to 0.5 mg/L, and the oxidant dosed samples allowed to sit at room temperature for 5 or 10 minutes. After the desired exposure time had elapsed, a portion of the sample was filtered through a sterile membrane filter to capture the bacteria cells, with the filter then washed with sterile phosphate buffer to remove remaining biocide. Filter membranes were then transferred to a petri dish containing solidified, sterile media using sterile forceps. After incubation at 35-37°C for 48 hours, the active bacteria were quantitated in cfu/mL, and these results used to calculate the log reduction compared to control samples.

Results from laboratory studies clearly show that MOS is the superior biocide as compared to bromine for the inactivation of *P. aeruginosa* (Figure 7) and *L. pneumophila* (Figure 8). Tests conducted with *P. aeruginosa* used an oxidant dose of 0.25 mg/L. At a contact time of 5 minutes, MOS achieved a 3.3 log inactivation, which was comparable to the 3 log inactivation achieved by bromine. After a 10 minute contact time, however, MOS achieved a log inactivation of 5.7 which the bromine sample showed a log inactivation of only 3.1. MOS was found to be similarly more effective than bromine for *L. pneumophila* inactivation as well, achieving a 5.8 with a 5 minute contact time while bromine was able to produce a log inactivation of only 2.9. As before, increased exposure time did not result in an increased inactivation for the bromine sample, and no effect was seen for MOS in this case since the maximum detection limit for this test was a log inactivation of ~5.7-5.8.

Laboratory data further validates earlier observations that MOS is a highly effective biocide when applied in a high pH environments simulating typical cooling tower waters. Further, this data also provides the first side-by-side comparison of MOS with aqueous bromine, which is often thought to be the best biocidal choice for high pH disinfection. It is very likely that the combined impact of hypochlorite and hydrogen peroxide thought to be present in MOS results in the observed superior disinfection seen in these tests.

References

1) (a) Bajszár, G. and Dekonenko, A. 2010 “Stress-induced Hsp70 Gene Expression and Inactivation of *Cryptosporidium parvum*

oocysts by Chlorine-Based Oxidants” Applied and Environmental Microbiology 76, 6: 1732-1739. (b) Groupé, V., Engle, C.G., Gaffney, P.E. and Manker, R.A. 1955, “Virucidal Activity of Representative Antiinfective Agents Against Influenza A and Vaccinia Viruses,” Applied and Environmental Microbiology; 1955 3: 333-336. (c) Venczel, L.V., Likirdopulos, C.A, Robinson, C.E., and Sobsey, M.D., 2004, “Inactivation of Enteric Microbes in Water by Electro-chemical Oxidant from Brine (NaCl) and Free Chlorine,” Water Science and Technology; 50, 1; 141-146. (d) Venczel, L.V., Arrowood, M., Hurd, M., and Sobsey, M.D., 1997 “Inactivation of *Cryptosporidium parvum* Oocysts and *Clostridium perfringens* Spores by a Mixed-Oxidant Disinfectant and by Free Chlorine,” Applied and Environmental Microbiology; 63, 4; 1598-1601.



Figure 1- Photograph showing an example of an OSG system.

Parameter	Pre-MOS Disinfection	MOS Disinfection
Free Chlorine Residual (mg/L)	0.27	0.09
Total Chlorine Residual (mg/L)	0.38	0.16
Ammonia (mg/L)	Not Measured	0.84
pH	8.63	8.57
Conductivity (mS)	993	667
Total Hardness (mg/L)	70	73
Alkalinity (mg/L)	149	153
ORP Set Point (mV)	400	275
Average Mild Steel Corrosion Rate (mpy)	0.5	0.1
Average Copper Corrosion Rate (mpy)	0.02	0.015
Typical Microbial Load (CFU/mL)	1,000	1,000

Table 1- General water quality parameters measured during the comparison period.

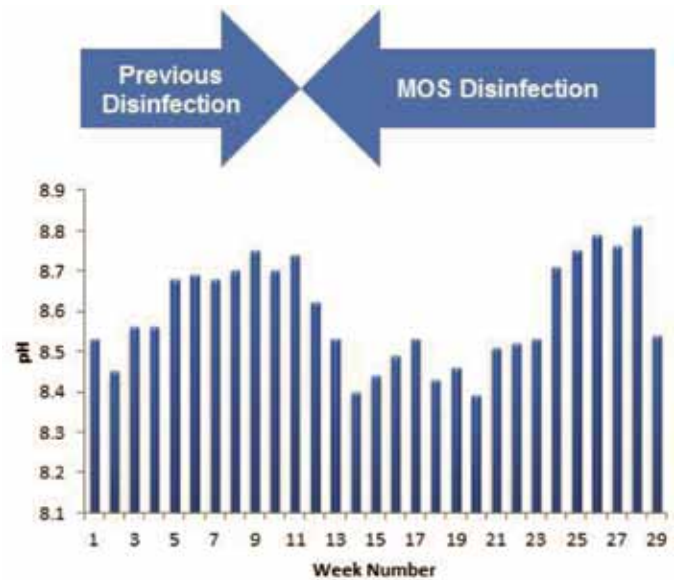

Figure 2- Graph showing the pH of the cooling water both before and after the transition to the use of MOS.



Leading the way in quality, service, and value.

Midwest Cooling Towers leads the way for you with a full range of cooling tower products and services for your project. We are a complete cooling tower supply company. Our skilled and experienced team can support you in every step — design, fabrication, installation.

Contact us today and see how much value we can bring to your cooling tower project.

- Crossflow & counterflow cooling towers with wood or FRP structures
- Custom lumber fabrication and treating
- Fiberglass fan stacks and water distribution systems
- Non-skid fiberglass fan deck and hot water basins
- Corrugated FRP casing and louvers
- Fans, gears, drive shafts, motors, supports
- Flow control valves, nozzles, grommets
- Fill and drift eliminators
- Hardware, brace connectors, base anchors
- Replacement parts for all models and manufacturers
- Budget optimization and thermal upgrade studies
- Complete engineering services
- Reconstruction and thermal performance upgrades
- Maintenance and service contracts
- Emergency response and repair



WWW.MWCOOLING.COM

Midwest Cooling Towers • 1156 E. Highway 19 • Chickasha, OK 73018 • Tel 405 224 4622 • Fax 405 224 4625

Representative Offices throughout the country



**WE
ACCEPT**



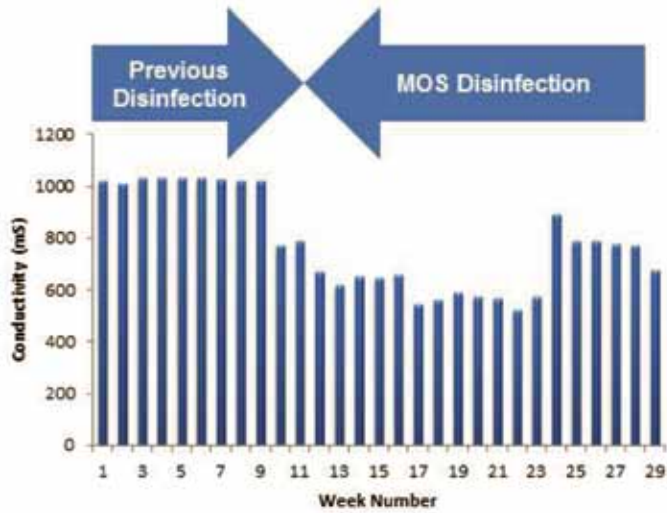

Figure 3- Graph showing the conductivity of the cooling water both before and after the transition to the use of MOS.

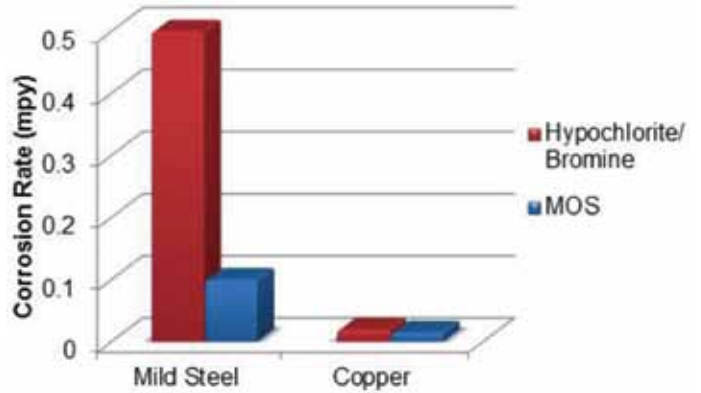

Figure 6- Graph showing cooling mild steel and copper corrosion rates using hypochlorite/bromide and MOS disinfection chemistries.

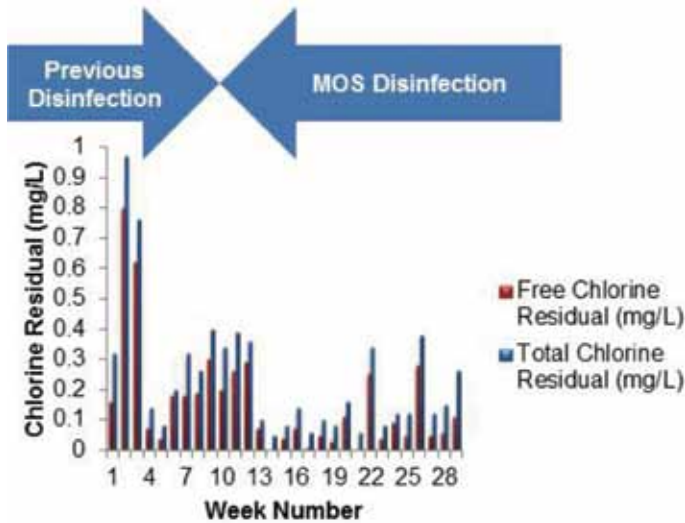

Figure 4- Graphs showing the Free Available Chlorine and Total Chlorine residuals present in the cooling water measured both before and after the transition to the use of MOS.

Comparative Inactivation of *P. aeruginosa*

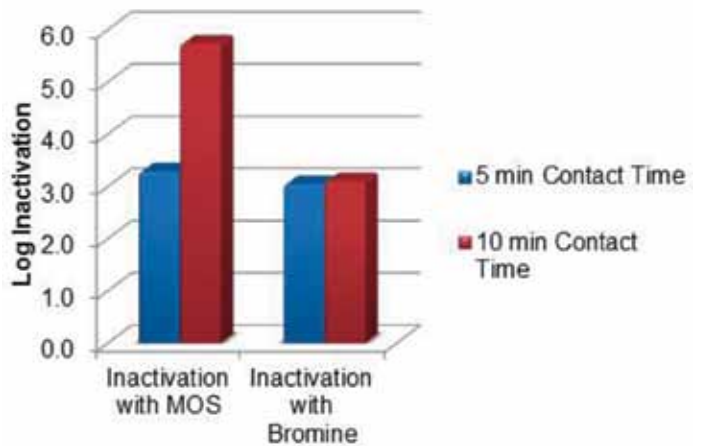

Figure 7- Graph showing the comparative inactivation of *P. aeruginosa* by both MOS and bromine with a 0.25 mg/L dose for both 5 and 10 minute contact times.

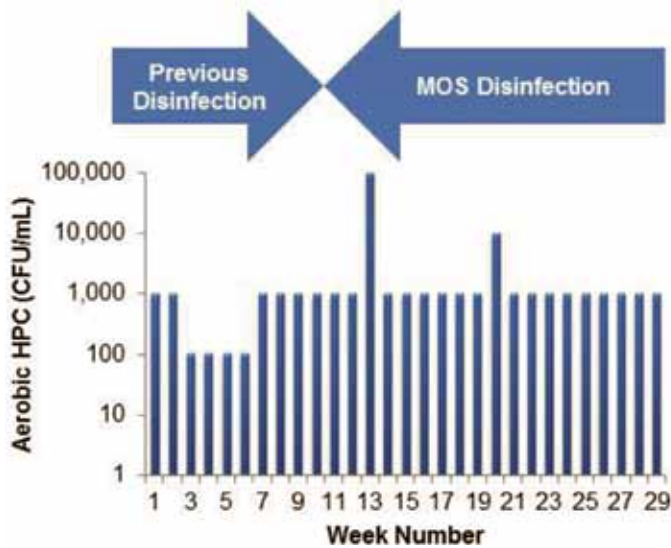

Figure 5- Graph showing the weekly enumeration of the microbial population in the cooling tower water both before and after the transition to the use of MOS.

Comparative Inactivation of *L. pneumophila*

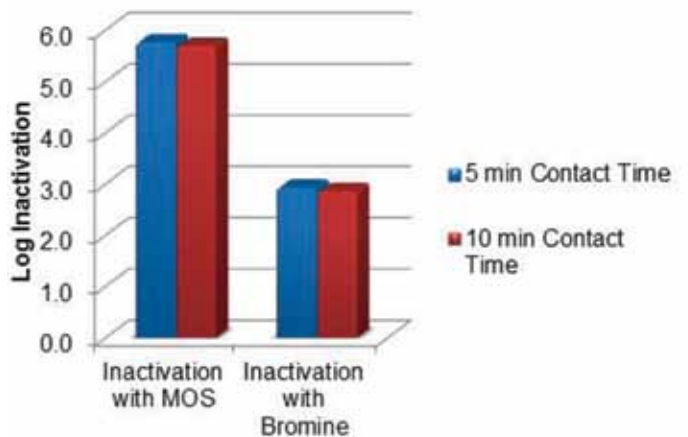

Figure 8- Graph showing the comparative inactivation of *L. pneumophila* by both MOS and bromine with a 0.5 mg/L dose for both 5 and 10 minute contact times.

SPX® 



FIND THE KEYS

To Unlock Top Performance – Marley NC®

Marley offers the most keys to cooling tower top performance: • Highest cooling capacity* • Certified sound • Lowest drift rates*. Unlock your results with the new, enhanced Marley NC. Let's open the conversation together:

913.664.7554 | spxcooling@spx.com



spxcooling.com/keys

*As compared with other leading manufacturers

MARLEY® 

The Impact of Ionic Strength Upon Inhibitor Speciation and Efficacy

Robert J Ferguson, French Creek Software, Inc.

ABSTRACT

Previous papers reported observations on the impact of pH, and inhibitor protonation state, on inhibitor efficacy (Ferguson, 2013, Griffiths, 1979, Ramsey, 1985, Tomson, 2002, Hunter, 1993). The data generated in these works is applicable in the low to moderate ionic strength covered. The conditions for the studies did not extend to the high total dissolved solids (TDS) and ionic strength regions encountered in critical current applications for scale inhibition. Water reuse by cooling water systems pushes the operating ion ionic strength well beyond traditional limits, as do other water reuse applications involving reverse osmosis. High TDS studies were conducted in the range of interest to provide insight into scale inhibitor speciation at high ionic strength. pKa's were measured in solutions "spiked" with NaCl (0 to 200,000 mg/L) to provide data for evaluating scale inhibitor species in high T.D.S. systems. pKa profiles were developed for commonly applied polymers and phosphonate inhibitors.

Background

The impact of pH and protonation state on treatment efficacy is observed in many areas of water treatment. Chlorination provides an example with the protonated form of hypochlorous acid being observed to have much more biocidal activity than the dissociated hypochlorite form. Adsorption studies of inhibitors used as squeeze treatments in oil field applications provide another example of the efficacy of dissociated versus protonated inhibitor forms (Breen 1990). In some cases, such as bromination, the impact of dissociation state on efficacy is arguably negligible.

Similar observations have been made concerning the impact of pH and protonation state on efficacy in the case of scale inhibition by phosphonates and polymers, (Ferguson, 2014, Griffiths, 1979, Ramsey, 1985, Tomson, 2002, Hunter, 1993).

Polymers and scale inhibitors are typically weak acids and scale inhibitors dissociate like other acids as per Equation 1:



with a dissociation constant that might be generalized as:



and a pKa defined as:

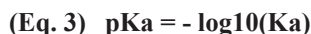

By definition, pKa is the pH where 50% of the acid for a given dissociation step will be in the protonated form, and 50% in the dissociated form. Knowing the pKa for the final dissociation step of an inhibitor can be critical when the dissociated and protonated forms have significantly different efficacy as inhibitors. A



Robert J Ferguson

conservative method for employing the dissociation state is to assume that the dissociated inhibitor concentration for the final step is the active species.

The Henderson-Hasselbach equation is derived by taking the log10 of both sides of equations 2, and rearranging :

$$\text{(Eq. 4) } \text{pH} = \text{pKa} + \log_{10} \left[\frac{\{\text{H}^+\} \{\text{Inhibitor}^-\}}{\{\text{H-Inhibitor}\}} \right]$$

Understanding the impact of pH upon the relative efficacy of an inhibitor can be key to providing the optimum inhibitor dosage and in

assuring that the minimum effective active inhibitor is present. In the simplest case, a simple inhibitor may have almost 100% efficacy in a pH range where it is almost completely dissociated,

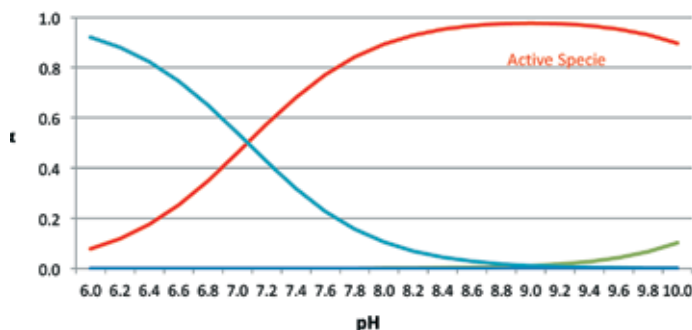

Figure 1: HEDP Distribution of Species

and close to 0% efficacy in a pH range where the inhibitor is almost completely protonated. This scenario has been reported for simple phosphonates such as HEDP (1-hydroxyl ethylidene-1,1-diphosphonic acid). Profiles comparing the protonation state and inhibitor efficacy for the simple phosphonates indicate that the final dissociation constant (pKa) is controlling with minor, if any, contribution from lower dissociation states. The dissociation profile for HEDP at low TDS is outlined in Figure 1.

Ferguson demonstrated that scale inhibitor dosage optimization model correlation accuracy increased dramatically when the minimum effective dosage used was the dissociated inhibitor concentration [Inhibitor⁻] rather than total inhibitor concentration [Inhibitor⁻] + [H-Inhibitor]. Models were developed based upon induction time extension (Ferguson 2004, Tomson et al 1992).

$$\text{(Eq. 5) } \text{Induction Time} = \frac{[\text{inhibitor}]^M}{k [\text{Saturation Ratio} - 1]^{P-1}}$$

Where: Induction Time is the time before crystal formation and growth occurs;

Inhibitor is the concentration of either the total inhibitor or dissociated inhibitor only



45TH TURBOMACHINERY & 32ND PUMP SYMPOSIA

HOUSTON, TEXAS | SEPTEMBER 12 - 15 2016 | GEORGE R. BROWN CONVENTION CENTER

REGISTER

45TH TURBOMACHINERY & 32ND PUMP SYMPOSIA

The premier conference for Turbomachinery and pump professionals.

DEVELOPED FOR THE INDUSTRY, BY THE INDUSTRY.

ONLINE REGISTRATION OPEN NOW

TPS.TAMU.EDU



FOR MORE INFORMATION

EMAIL: info@turbo-lab.tamu.edu

OR VISIT: TPS.TAMU.EDU

k is a temperature dependent constant;
 Saturation Ratio is the degree of super-saturation;
 P is the critical number of molecules in a cluster prior to phase change

Figures 2 and 3 profile the correlations obtained for a copolymer dosage optimization model for calcium phosphate. Figure 2 shows

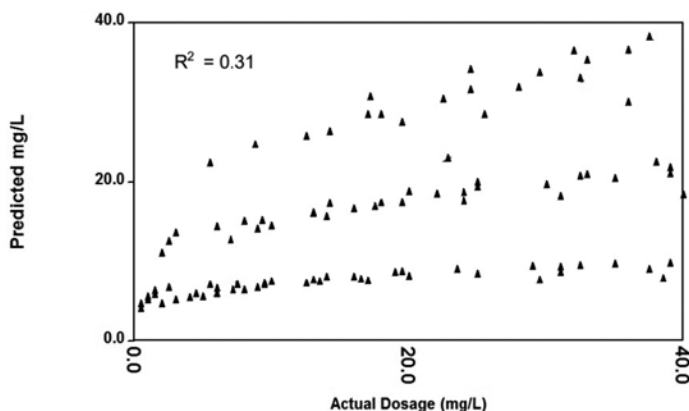

Figure 2 Predicted Versus Observed Dosages For Correlation to Total Inhibitor

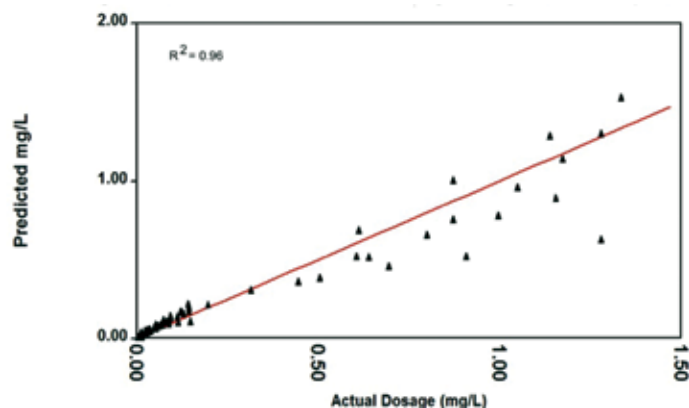

Figure 3 Predicted Versus Observed Dosages Using Dissociated Specie.

the model to the total inhibitor dosage while Figure 3 depicts the predicted versus observed values when correlated to the dissociated specie only. It can be seen that, in this case, correlation to the total inhibitor concentration provided a poor model ($r^2 = 0.31$) while the correlation to the dissociated form is much higher ($r^2 = 0.96$).

The use of dissociated species for optimizing dosage is particularly important when the pH of the water being treated is less than the pKa for the final dissociation step. Commonly used phosphonates, for example, are typically over 80% or more in the dissociated form at pH above 7.5. The dissociated form of polymers, on the other hand, may be present at less than 10% in the neutral pH range. Even lower concentrations will be present at an acid pH.

How TDS Affects pKa

Ka values, and their base ten logarithm pKa, are typically measured at a fixed ionic strength, and then extrapolated to infinite dilution. A conditional pKa' is the value measured at specific conditions of state (Temperature, Pressure, Ionic Strength), or corrected to those conditions from the value at infinite dilution. As ionic strength varies, the activity coefficients outlined in Equation 6 vary, and change the value of the dissociation constant, Ka.

$$\text{(Eq 6)} \quad K_a = \alpha_H [H] \frac{\alpha_{\text{Inhibitor}} [\text{Inhibitor-}]}{(\alpha_H \text{-Inhibitor} [\text{H-Inhibitor}])}$$

Where: Ka is the dissociation constant for Eq. 1;

α_H is the activity coefficient for the hydronium ion

$\alpha_{\text{Inhibitor}}$ the activity coefficient for the dissociated form of the inhibitor;

$\alpha_H \text{-Inhibitor}$ is the activity coefficient for the protonated inhibitor form;

[H] the hydronium ion concentration;

[Inhibitor-] the dissociated inhibitor concentration; and

[H-Inhibitor] the protonated inhibitor concentration.

Taking the logarithm of both sides of Equation 6 and substituting pH for hydronium ion activity, and then rearranging produces Equation 7, which is the Henderson-Hasselbach equation.

$$\text{(Eq. 7)} \quad \text{pH} = \text{pK}_a + \log_{10} \frac{\alpha_{\text{Inhibitor}} [\text{Inhibitor}]}{\alpha_H \text{-Inhibitor} [\text{H-Inhibitor}]}$$

Please note that the Inhibitor will be 50% dissociated when the pH is equal to the pKa at infinite dilution. If a conditional pKa' (Equation 8) is used rather than the pKa at infinite dilution, half of the inhibitor will be in the active, dissociated form, when the pH is equal to the pKa'.

$$\text{(Eq. 8)} \quad \text{pK}_a' = \text{pK}_a + \log_{10} (\alpha_{\text{Inhibitor}}) - \log_{10} (\alpha_H \text{-Inhibitor})$$

Measured pKa' values change as ionic strength increases or decreases with all other parameters being constant.

Ions in water have a decrease in their energy as ionic strength increases. In very dilute solutions, the predominant effect causing a decrease in activity is the long range repulsion between same charge molecules and the attraction between oppositely charged molecules. As ionic strength increases, the molecules become closer, and their hydration layers begin to interact, adding a short range factor for repulsion and attraction. At extreme concentrations, only a few water of hydration molecules might separate ions, and the short range effects become extremely significant. At the extreme ionic strength (above about 6 molal), the activity of water also decreases significantly as water molecules increasingly become tied up in hydration layers around molecules. So there are several levels of ion interactions that can decrease the available energy for reaction. This decrease in energy is modeled using an activity coefficient. Two basic approaches are used to model activity coefficients and are discussed in this section of the paper: those derived from the Debye - Hückel equations, and those that are extended to refine the short term interactions using virial expansions, in the form of the Pitzer or equivalent equations.

The basic correlations used for activity in pKa correlations versus ionic strength are to the square root of ionic strength, or a function including the square root of ionic strength. Most models for variation of pKa with TDS or ionic strength tend to ignore the short term interactions and reflect only long range interactions between ions.

Debye - Hückel Activity Coefficients

Activity corrections based upon the Debye - Hückel limiting law (Equation 9), are widely used in water treatment for scale prediction and modelling, even though such models are applicable to only

the most dilute solutions. This is the activity model that was used in the original Langelier Saturation Index.

$$\text{(Eq. 9) } \log \gamma_i = -A z_i^2 \sqrt{I}$$

where A is a temperature dependent constant (0.5092 at 25oC)
z is the ions electrical charge (e.g. +1 for Na)
I is the solution ionic strength $I = \frac{1}{2} \sum m_i z_i^2$
m_i is the molality

Robinson and Stokes worked with the Debye-Hückel method for activity coefficients and published the most common method for estimating the long range effect of charge interactions, the Debye-Hückel equation:

$$\text{(Eq. 10) } \log \gamma_i = - \frac{A z_i^2 \sqrt{I}}{1 + \hat{a}_i B \sqrt{I}}$$

where A is a temperature dependent constant (0.5092 at 25oC)
B is a temperature dependent constant (0.3283 at 25oC)
z is the ions electrical charge (e.g. +1 for Na)
I is the solution ionic strength
 \hat{a} is an empirical ion size
m_i is the molality

Davies (Bethke, 2008) published a useful variant in 1962 that includes an adjustment factor to compensate for the short range interactions:

$$\text{(Eq. 11) } \log \gamma_i = -A z_i^2 \left[\frac{\sqrt{I}}{1 + \sqrt{I}} \right] - 0.3 I$$

Helgeson (1969) introduced a most useful derivation of the Debye-Hückel and Davies equations that incorporates an ion specific adjustment for the impact of higher ionic strength and long range interactions:

$$\text{(Eq. 12) } \log \gamma_i = - \frac{A z_i^2 \sqrt{I}}{1 + \hat{a}_i B \sqrt{I}} + \hat{B} \sqrt{I}$$

where \hat{B} is a temperature dependent adjustment parameter.

The Helgeson extension is used in geochemical models and is commonly called the B-dot equation. It is reportedly useful to 3 molal ionic strength in NaCl based systems and up to 1 molal in other solutions. \hat{B} values have been published in the temperature range of 0 °C to 300 °C.

The combination of the B-dot equation format and a full speciation using an ion association model is perhaps the most commonly used method for scale prediction and refined index calculation in low to the lower high end of ionic strength brines. The combination has been used successfully in the 3 to 6 molal range for NaCl based brines. Further refinements are desirable in even higher TDS brines.

Virial Expansion Activity Models

Coefficients for the Debye-Hückel derived activity coefficient models have primarily been derived in NaCl based systems. When dealing with other brines, such as NaBr based completion fluids, other methods are more appropriate. These methods start with a Debye-Hückel based factor for long term interactions and expand it to model the short term interactions of ions. The virial methods typically lump the ion association effects into the overall model

and are most useful in extreme TDS brines, and high to extreme non-NaCl based brines.

The derivation of the virial expansion method is beyond the scope of this paper. Key points for the use of scale prediction software based upon virial methods include the two types of Virial models in general use (Pitzer and the Havey-Moller-Weare approach), limitations of data for the models, and a caution on the use of virial methods beyond the range of their data (Zemaitis, 1986).

Measurement of pKa'

Commercial scale inhibitors are technical grade chemicals and subject to variation. Specifically, polymers used in water treatment are a mixture of molecular weight fractions. Ideally tests would be conducted on purified inhibitors. Technical grade scale inhibitors, on an "As Is" basis were used for these studies.

The pKa' determinations were quite simple. Dilute samples were prepared for each inhibitor and back titrated to pH 2 using 0.1 molar hydrochloric acid. Samples with a broad range of ionic strength were prepared using sodium chloride. The samples were then titrated to pH 12 using 0.1 molar sodium hydroxide. pKa's were then calculated from the pH – titrant volume data. The end point for the pKa's was calculated using Excel® spreadsheets including CurTiPot™ (Gutz, 2014) for evaluating titration data. End points were selected at the point of maximum slope where the first derivative reaches a maximum value and the second derivative passes through zero. A CurTiPot™ Screenshot is included in the Appendix.

Solutions were observed for turbidity and any "salting out" effects. Salting out can occur when polymers are unable to maintain hydration at high ionic strength. No such effects were observed during this studied.

Correlating pKa versus Ionic Strength

The pKa at infinite dilution is the starting point for applying the laboratory data to practical water treatment inhibitor dosage optimization. Multiple regression was used to correlate the measured pKa' values to ionic strength using Equation 7 and a form of Equation 9 for activity corrections.

$$\text{(Eq. 13) } pK_a' = pK_a - A z_i^2 \left[\frac{\sqrt{I}}{1 + \sqrt{I}} \right] - \hat{B} I$$

Variables used for the regression analyses were:

pKa' the pKa measured by titration at a given TDS/Ionic Strength

pKa the intercept or pKa at infinite dilution

A is a temperature dependent constant (0.5092 at 25oC)

z is the ions electrical charge (e.g. +1 for Na)

I is the solution ionic strength $I = \frac{1}{2} \sum m_i z_i^2$

\hat{B} is a temperature dependent adjustment parameter.

Example pKa profiles from this study versus TDS are depicted in Figures 4 through 6.

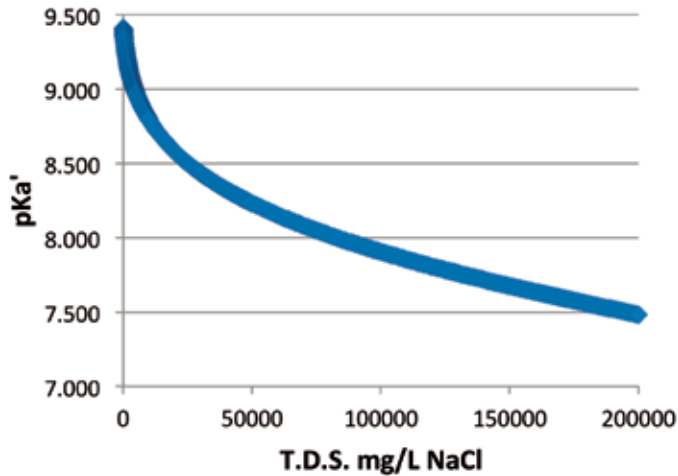

Figure 4: HEDP pKa' versus T.D.S.

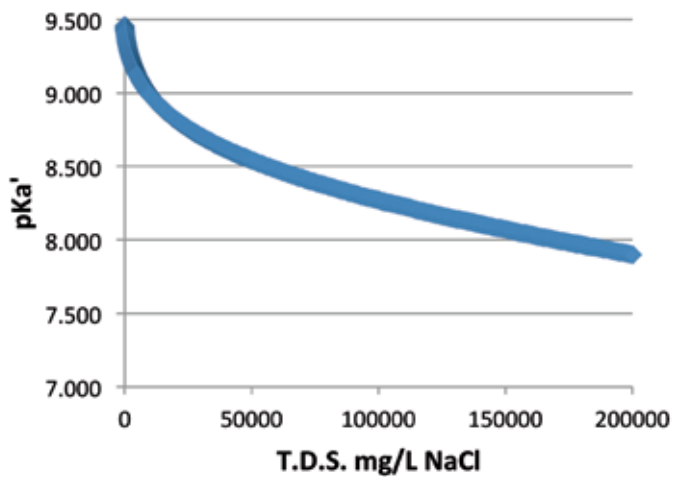

Figure 5: AA-AMPS pKa' versus T.D.S.

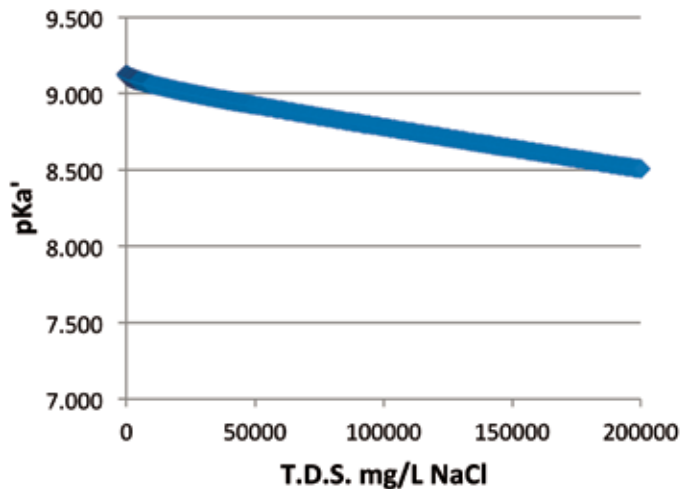

Figure 6: PMA pKa' versus T.D.S.

Results

Three inhibitors were evaluated for this initial study: HEDP (1,1-hydroxyethylidene diphosphonic acid), AA-AMPS (a copolymer of acrylic acid and 2-acrylamido-2-methylpropanesulfonic acid), and an enhanced polymaleic acid polymer.

Data from the HEDP titrations was consistent and resulted in a strong correlation (95% confidence level for correlation, $p < 0.001$ for individual parameters). Predicted versus observed values are plotted in figures 7, 8, and 9. The data was also in reasonable agreement with other published values from pKa determinations conducted at a single ionic strength (Ferguson, 2014, Griffiths, 1979, Ramsey, 1985, Hunter, 1993).

Results are summarized in Figure 4, Figure 7, and Figure 10. First and second dissociation steps were extrapolated to infinite dilution and found to be 5.05 and 9.58 respectively. Titrations of the polymers demonstrated a similar trend of decreasing pKa with increases in TDS (ionic strength).

Example Profiles for Phosphonate and Polymeric Inhibitors

Profiles of pKa as a function of TDS, goodness of fit for the pKa correlations, and a distribution of species as a function of pH and TDS were prepared to demonstrate the trends for each inhibitor evaluated. Figures 10, 11, and 12 profile the fraction (α) of the total inhibitor concentration in the dissociated, active, form as a function of TDS and pH. The profiles demonstrate that the total inhibitor dosage required for a given set of conditions decreases dramatically with increases in TDS and pH.

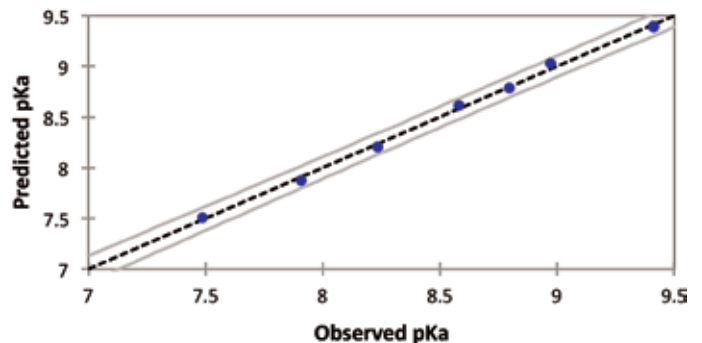

Figure 7: Predicted versus Observed pKa for HEDP

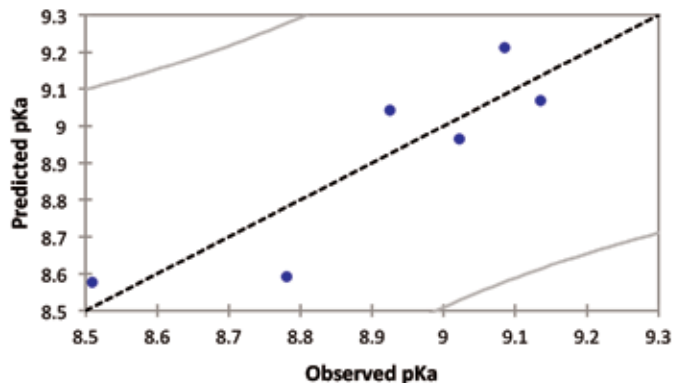

Figure 8: Predicted versus Observed pKa for AA-AMPS



AHREXPO[®]

Las Vegas

CONVENTION CENTER

JAN 30 - FEB 1 2017

CO-SPONSORS



THE WORLD'S LARGEST HVACR MARKETPLACE | AHREXPO.COM



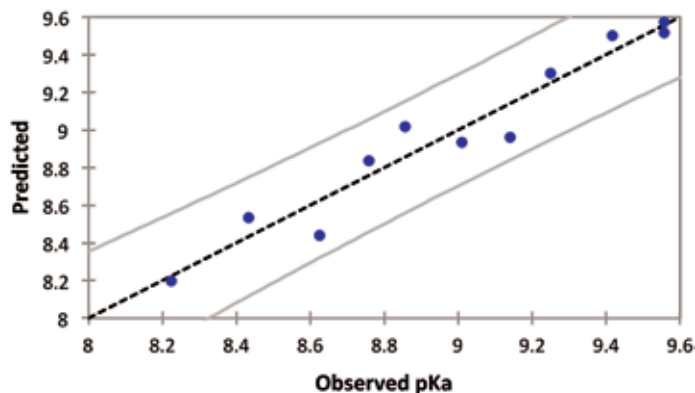

Figure 9: Predicted versus Observed pKa for PMA

Impact of High TDS upon Speciation and Inhibitor Activity

Previous papers documented the efficacy of the dissociated inhibitor form, with respect to the protonated forms which demonstrated little, if any, activity (Ferguson, 2014, Griffiths, 1979, Ramsey, 1985, Tomson, 2002, Hunter, 1993). The dissociated form was found to be the active component. The decrease in pKa with increasing TDS elicits over a ten fold increase in the concentration of the active, dissociated form, as TDS increase from low TDS (500 mg/L as NaCl) to extreme TDS in the 30,000 (seawater) to 100,000 mg/L (flow back) range. This implies that scale inhibitors can be expected to perform at significantly lower total inhibitor dosages at high TDS than at low TDS, all other parameters being constant.

A common standard method for static inhibitor performance tests is conducted in the presence of seawater levels of NaCl. This results in a dramatic shift in the distribution of inhibitor species towards the active dissociated form. Scale evaluations run at high TDS can not necessarily be expected to provide even “ball park” dosage recommendations for lower TDS systems. Anecdotally, it has been reported that almost any inhibitor can perform well in high TDS tests, but might not perform as well in comparable lower TDS waters.

Future Work

This paper reports on progress towards developing a more thorough understanding of the role of speciation in inhibitor performance modelling and dosage optimization. Further work is in progress to evaluate most of the commonly used scale inhibitor physical properties such as pKa.

Additional pKa evaluations will be performed on the PMA inhibitor due to the flatness of its low to moderate TDS response.

The next phase of evaluations will add the impact of temperature on pKa and distribution of species, as well as static inhibitor performance testing. Data derived from these studies will be published and incorporated into dosage optimization models for water treatment scale control applications including oil and gas brines, mining process waters, reverse osmosis, and cooling water.

References

- Bethke, C.M. (2008), *Geochemical and Biogeochemical Reaction Modeling*, Cambridge Press, pp 118-119.
- Breen, P.J., Diel, B.N., and H.H. Downs, (1990), “Correlation of Scale Inhibitor Structure With Adsorption Thermodynamics and Performance in Inhibition of Barium Sulfate in Low-pH Environments,” Society of Petroleum Engineers, Annual Technical Conference.
- Ferguson, R.J., (1993), “Developing Scale Inhibitor Dosage Models”, NACE EUROPE '93, Sandefjord, Norway.
- Ferguson, R.J., (2011), “Mineral Scale Prediction and Control at Extreme TDS”, International Water Conference.
- Ferguson, R. (2011), “Thermodynamics and Kinetics of Cooling Water Treatment”, Association of Water Technologies.
- Ferguson, R.J., (2014), “The Impact of pH & Protonation State on Scale Inhibitor Activity”, International Water Conference.
- Griffiths, D.W., Roberts, S.D., and Y.T. Liu, (1979), “Inhibition of

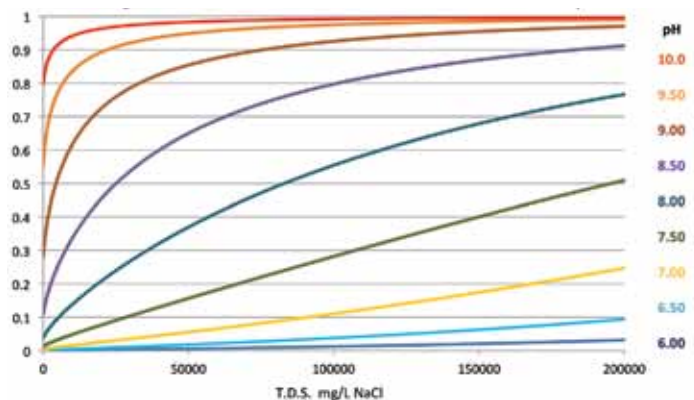

Figure 10: HEDP Dissociation Fraction versus T.D.S. at various pH

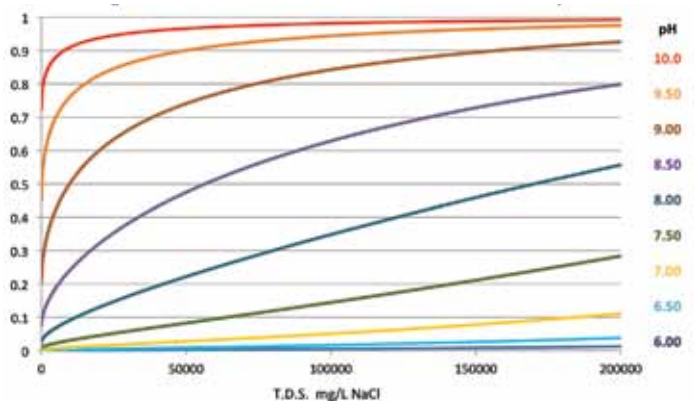

Figure 11: AA-AMPS Dissociation Fraction versus T.D.S. at various pH

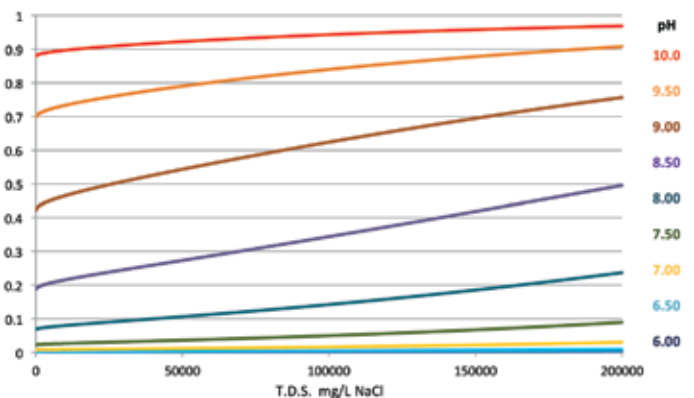

Figure 12: PMA Dissociation Fraction versus T.D.S. at various pH

Calcium Sulfate Dihydrate Crystal Growth by Phosphonic Acids – Influence of Inhibitor Structure and Solution pH,” Society of Petroleum Engineers, International Symposium on Oil Field and Geothermal Chemistry.

Gutz, I. G. R., (2014), CurTiPot – pH and Acid–Base Titration Curves: Analysis and Simulation freeware, version 4.0 http://www2.iq.usp.br/docente/gutz/Curtipot_.html

Helgeson, H.C. (1969), Thermodynamics of Hydrothermal Systems at Elevated Temperatures and Pressures, American Journal of Sciences, 267, 729 – 804.

Hunter, M.A., (1993), Alkalinity and Phosphonate Studies for the Scale Prediction and Prevention, Rice University.

Ramsey, J.E., and L.M. Cenegy, (1985), “A Laboratory Evaluation

of Barium Sulfate Scale Inhibitors at Low pH for Use in Carbon Dioxide EOR Floods,” Society of Petroleum Engineers, Annual Technical Conference.

Robinson, R.A., Stokes, R.H. (2002) Electrolyte Solutions, Dover Publications, pp 229-233.

Tomson, M.B., Fu, G., Watson, M.A. and A.T. Kan, (2002), "Mechanisms of Mineral Scale Inhibition," Society of Petroleum Engineers, Oilfield Scale Symposium, Aberdeen, UK, 2002.

Zemaitis J.F., Clark, D.M., Rafal, M., Scrivner, N.C. (1986), Handbook of Aqueous Electrolyte Thermodynamics, AIChE, pp 47-66.

Acknowledgements

This paper benefited from laboratory assistance from Mike and Leslie Standish while our laboratory was in final phases of construction.

Appendix

CurTiPot™ Screen Shot

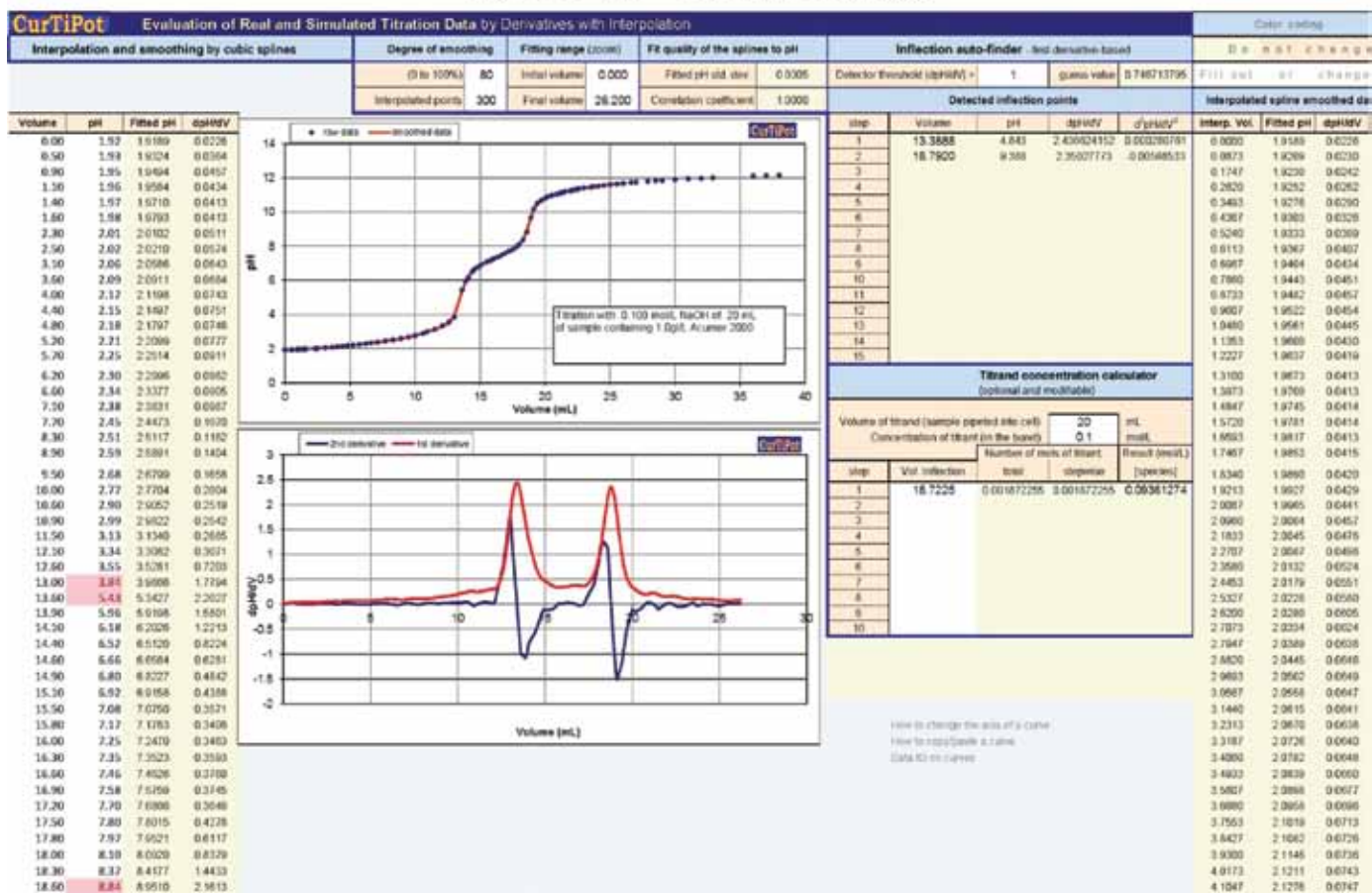

Improve System Performance and Reduce System Corrosivity Using a Novel Biocide for Cooling Towers

Chris Baron, Stephanie Hammond, PhD;
Solenis

Abstract

Traditional treatment programs for recirculating systems using strong oxidizing biocides often result in elevated general corrosion rates. A novel, mild oxidizing biocide system that provides superior microbial control of cooling systems at considerably lower corrosivity has been introduced. The novel biocide is produced on site using dedicated feed equipment to convert a strong oxidizer, sodium hypochlorite, into a mild oxidizer that selectively targets mesophilic bacteria and algae without detrimental corrosive side-reactions. Typical performance improvements of cooling systems using this program include a substantial reduction in azole corrosion inhibitor feeds, an increase in cycles of concentration, and a decreased cleaning frequency for condensers.

Keywords

Algae, Biocide, Bacteria, Biofilm, Bromide-Activated Chloramine (BAC), Cooling Water Treatment, Corrosion, Industrial Water Treatment, Microbial Control, Microbial Growth, Microbiological Fouling, Oxidation-Reduction Potential (ORP), Oxidizer.

Introduction

Cooling of mechanical processes is essential to the operation of most manufacturing sites, including power plants, refineries, steel mills, and chemical plants. Without adequate cooling, many of these sites are forced either to curtail production or to face the prospect of unscheduled shutdowns due to premature equipment failures. One of the primary causes of inadequate cooling is microbial contamination of the recirculating cooling system. Microbes inhibit heat transfer directly by forming highly-insulating biofilms on the surfaces of heat exchangers. These biofilms are also commonly found in the film fill of a cooling tower, where they can inhibit water flow, increase the physical stress on the tower support structure, and decrease cooling capacity as measured by the Approach to Wet Bulb temperature.

The growth of microbes in recirculating cooling systems is controlled primarily through the addition of microbiocides, but these compounds can often cause problems.^{1,2} Strong oxidizers, by far the largest category of microbiocides used in cooling systems, elevate the system Oxidation-Reduction Potential (ORP) over 450 mV, which leads to elevated general corrosion rates. These conditions also call for increased feeds of ancillary chemicals (i.e., polymers, corrosion inhibitors, etc.) because the strong oxidants react directly with these compounds. Traditional alternatives to strong oxidizers, which include stabilized halogens and non-oxidizing biocides, are typically much more expensive to use than strong oxidizers.

Recent developments in microbiocide technology for recirculating cooling systems have included advances in mild oxidizer



Chris Baron

technology. The initial success of bromide-activated chloramine (BAC), a mild oxidizer produced from the stoichiometric combination of ammonium bromide and sodium hypochlorite, were detailed in a previous paper in this journal.³ This paper details additional performance improvements that were achieved using this novel, patented technology for microbial control.

Bromide-Activated Chloramine

Bromide-activated chloramine (BAC) is produced from the stoichiometric combination of sodium hypochlorite (12.5%) and ammonium bromide (35%) as part of our patented microbiocide system.⁴ The novel oxidant is

produced on site using patented dosing and control equipment that adjusts the ratio of the two reactants in real time to compensate for degradation of the sodium hypochlorite. Without this feedback mechanism, the mole ratio of the two reactants would change as the sodium hypochlorite degrades, resulting in excess ammonia being fed into the cooling tower. This is undesirable because free ammonia is both a tremendous food source for microbes and a corrosive agent toward copper-based alloys. Additional negative consequences associated with using different reaction schemes and ratios for haloamines have been described previously.³

The patented, proprietary equipment and software of the biocide feed system (see Figure 1) allow for quantitative conversion of the ammonium bromide and sodium hypochlorite to the active BAC. Biocide performance can be monitored using a multitude of traditional techniques including Petri films, dip slides, Adenosine triphosphate (ATP), metal coupons, fouling factor 5-9, and visual inspections. Residual BAC levels are monitored directly using the N,N-diethyl-p-phenylene-diamine (DPD)-based total oxidizing chlorine test and, indirectly, by measuring ORP.

Stripping Of Biofilm

Biofilms are adherent communities of microorganisms (including multiple bacterial species, fungi, algae, yeast, and protozoa) that are encased in a self-produced extracellular matrix. Microorganisms within the biofilm can be up to 1,000 times more resistant to the effects of antimicrobial agents. The extracellular matrix is highly hydrated and composed of polysaccharides, proteins, and nucleic acids that hold the biofilm together in addition to protecting the biofilm from the external environment. This sticky surface can also capture suspended solids such as dirt or scale deposits in recirculating water systems. In many cases, the extracellular matrix can account for more than 90% of the biofilm mass, whereas the microorganisms account for less than 10%.

Additionally, biofilms are very insulating. Studies have shown that biofilms as small as 0.05 mm can reduce heat transfer by as much as 25%. To put this size in perspective, a typical piece of adhesive tape is 0.05 mm thick. Obviously, a reduction in heat transfer of this magnitude is very important when heat transfer directly relates to plant output (i.e., megawatt output in a power plant).

The extracellular matrix functions as an initial barrier that can delay biocide penetration into the biofilm by reacting with or consuming antimicrobial agents. An effective biocide must therefore penetrate the extracellular matrix to reach the microorganisms residing within the biofilm. Strong oxidizing biocides, such as hypochlorite, react with the organic surface layer of the biofilm and are consumed before reaching the biofilm interior.¹⁰ Chloramine biocides, stabilized with agents such as ammonia, amine, or hydantoin, react with components of the biofilm surface at a slower rate, thereby allowing the biocide to penetrate more deeply into the biofilm. Chloramine concentrations around 2 ppm are effective at disinfecting and removing biofilms in cooling towers.¹¹

Bac Is Not Aggressive Toward Copper-Based Alloys

Copper-based alloys (i.e., admiralty brass, 70/30 Cu-Ni, etc.) are often used in heat exchangers due to their general resistance to corrosion in aqueous environments and excellent heat exchanging ability. In summer months, when cooling systems are often stressed and microbiological fouling is typically the worst, high levels of biocide are often needed to maintain cooling system performance. However, high levels of strong oxidants are known to have a negative effect on the corrosion rates of copper-based alloys. Since a typical application of BAC often employs total oxidizing chlorine levels between 2 and 5 parts per million (ppm) throughout the course of the year, concern is often expressed regarding this biocide's influence on these materials.

Previous reports have shown that switching to BAC from strong oxidants resulted in a decrease in the corrosion rates of copper-based alloys, and that BAC was less aggressive toward azole-based corrosion inhibitors.^{3,12} The two investigations reported below confirm and further clarify the reduced corrosivity of BAC toward all metals and toward copper-based alloys in particular.

Investigation #1: Microbial control on a cooling tower system was maintained using chlorine dioxide. The admiralty brass corrosion rate was maintained below 0.2 milli-inches per year (mpy) via the addition of an azole corrosion inhibitor. However, in the summer months the chlorine dioxide was often unable to control algal growth without leading to either elevated corrosion rates or elevated corrosion inhibitor feed rates. BAC was proposed as the solution for this problem.

Results: Switching to BAC resulted in the removal of all algal growth in the cooling tower without any observed increase in admiralty brass corrosion rates or corrosion inhibitor feed rates. To confirm the observed corrosion rates (determined using an on-line Corrat®), a study was initiated on site to monitor the dissolved copper levels in the two towers. While no firm number has been established as the upper limit for copper in a cooling system, most water treatment professionals agree that copper should not exceed 100 parts per billion (ppb) and, if possible, should be maintained below 50 ppb. This study of dissolved copper levels at this site showed that over several months, these values, as shown in Figure 2, never exceeded 17 ppb. Additionally, no significant increase in dissolved copper was noted during the dose of BAC.

Investigation #2: A second site featured a large tower that utilized ClO₂ as the microbial control agent with a 550 mV ORP set point to control microbial growth. While microbial control was generally acceptable with this program, algae would often appear in the tower during the hot summer months. Other strong oxidants had been used in the past but were unable to maintain tower cleanliness without increasing the corrosion rate of copper to levels deemed unacceptable by the tower owner. BAC was proposed as a year-

round replacement for the existing treatment program.

Results: Switching to BAC reduced the system ORP to less than 400 mV. The new, lower system ORP made the tower owner comfortable enough to remove the azole-based corrosion inhibitor from the water treatment package. Subsequent corrosion coupon data from this site, shown in Table 1, revealed dramatically reduced corrosion rates for low carbon steel and equivalent corrosion rates for copper, even in the absence of any azole. Additionally, tower cleanliness improved and algae was eliminated over the BAC treatment period, which continues to this day.

Conclusions: Relative to strong oxidizers, BAC allows a cooling system to be operated at lower ORP. This minimizes the corrosivity of the water toward copper-based alloys without leading to increased microbial growth.

Case Studies

To date, BAC has been used to successfully control microbial growth in more than 50 cooling systems in North America. The following case studies highlight some of the typical improvements achieved commonly in these cooling systems.

Case Study 1: Recirculating Evaporative Cooling System in a Chemical Processing Plant

Background: The water quality at this site required that acid be added to the cooling tower a) to prevent scale formation and b) to allow for the use of sodium hypochlorite as the primary microbiological (MB) control agent. A mechanical failure of the acid tank meant that the tower operator was faced with an expensive, unplanned capital project to replace the tank. Solenis proposed a less-expensive alternative that eliminated the need for a capital project.

Solution: Solenis initiated a trial of BAC coupled with a switch to a Millenium™ corrosion inhibitor. Biocide was added twice daily and the corrosion inhibitor was base-fed using our OnGuard™ 2Plus to control the feed. Additionally, the number of tower cycles was increased from 4 to 5 since the pH no longer needed to be maintained below 8 to prevent scaling and microbial growth.

Results: The previous MB and tower treatment strategies had been effective, but the failure of the acid feed system required a change. Using BAC maintained the cleanliness of the system to previous standards (< 103 cfu/mL) as measured using dip slides; additionally, the tower was observed to be clean by visual inspection of the fill and basin. While corrosion rates and dissolved metal levels had also been acceptable prior to the change, values achieved using the BAC biocide program were slightly better. See Table 2 for a summary of the tower operating and performance conditions under the two microbial control programs.

Summary: The change from a strong oxidizer (sodium hypochlorite) to a mild oxidizer (BAC) allowed for the cooling system to be operated at a higher pH and gained an additional cycle of concentration on the cooling tower. An overall savings in treatment costs equivalent to 25% of the original treatment spend rate were realized by converting to the new tower operating conditions.

Case Study 2: Recirculating Evaporative Cooling Water System in a Power Plant

Background: This renewable fuel power plant had a cooling tower that was using surface water for make-up and was operating under zero liquid discharge conditions. The high level of total solids in the make-up water resulted in significant condenser fouling that required the plant to go off line several times per year for cleaning. While previous efforts at water treatment had focused primarily

on the inorganic scale deposition, BAC was proposed as a method for eliminating the organic components of the fouling film. See Table 3 for a summary of the tower operating and performance conditions for the two microbial control programs.

Solution: After an extensive review of system performance using an online fouling monitor, a trial using BAC was initiated.

Results: Fouling rates for the condenser were cut in half after switching from a hypobromite-based microbiological control program to one based on BAC. The reduction in system ORP also allowed for a reduction in system pH, which further reduced system scaling. See Table 3 for a summary of the tower operating and performance conditions for the two microbial control programs.

Summary: Implementation of the BAC program resulted in a dramatic decrease in condenser fouling and an elimination of unplanned outages. The next effect was an increase of 5% in the megawatt output of the site.

Conclusion

Efficient cooling in a recirculating cooling system is best accomplished when the heat exchanging surfaces are clean. Bromide-Activated Chloramine (BAC), the novel biocide described in this paper, reduces the fouling associated with microorganisms and also reduces the overall corrosivity in cooling water. These features allow for cost-effective microbial and corrosion control of a cooling system.

Acknowledgements

The authors wish to acknowledge Brian Martin of Solenis for his contributions.

References

- [1] "Maximizing MW Output Through the Latest in Biofilm Control in Cooling Systems" Power Magazine webinar, June 2014, <https://www.youtube.com/watch?v=0raRsenRWHM&feature=youtu.be>
- [2] Paulus, W. Microbiocides for the Protection of Materials: A Handbook Chapman and Hall: London, 1993
- [3] "Novel, Mild Oxidant Improved Cooling Water Treatment Performance Relative to Traditional Oxidizers" Presented by C. Baron at the Cooling Technology Institute Winter 2012 meeting, Houston TX
- [4] U.S. Patent numbers: Barak, A. Process for the Disinfection of Waters. US Patent 6478973B1, Nov. 12, 2002; Barak, A. Process and Compositions for the Disinfection of Waters: US 7067063B2, Jun. 27, 2006; Barak, A. Method and Apparatus for Treating Liquids to Inhibit Growth of Living Organisms: US 5976386, Nov. 2, 1999; Barak, A. Method of Treating Liquids to Inhibit Growth of Living Organisms: US 6132628, Oct. 7, 2000; Barak, A. Control of Development of Biofilms in Industrial Process Water: US 7189329, Mar, 13, 2007.
- [5] "Treatment and Performance Management for Cooling Waters" NACE International 2011 Expo, Houston, Texas, Paper 11388, Beardwood, E.S.
- [6] Hays, G.F., and Haaland, J.M., Performance-Based Control System, U.S. Patent #5,855,791, June 1999.
- [7] Beardwood, E.S., Hays, G.F., and Knudson, J.G., Performance-Based Control System, U.S. Patent #6,068,012, May 30, 2000.
- [8] Beardwood, E.S., Hays, G.F., and Knudsen, J.G., Performance-Based Control System, U.S. Patent #6,510,368 B1, June 31, 2003.

- [9] "Standard Recommended Practice for On line Monitoring of Cooling Waters" NACE RP-0189-2002, Item No 21041, NACE International, P.O. Box 218340, Houston, Texas 77218-8340, NACE International.
- [10] LeChevallier, M. W.; Cawthon, C. D.; Lee, R. G. Appl. Environ. Microbiol. 1998, 54, 2492-2499
- [11] Türetgen, I. Biofouling 2004, 20, 81-85.
- [12] "Novel Biocide Program Maintains Condenser Cleanliness For Power Plant" Presented by C. Baron at the Electric Utility Chemistry Workshop, June 2013



Figure 1. The biocide feed system.

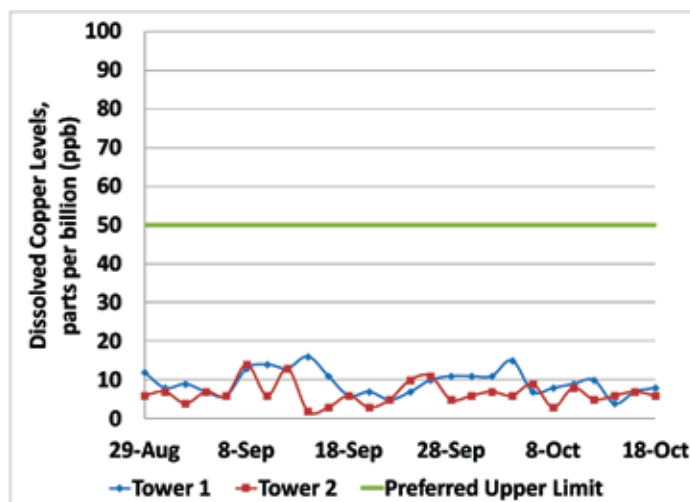

Figure 2. Dissolved copper levels on the two cooling towers.

	Corrosion Rate, mpy	
	Carbon Steel	Copper
ClO₂/Azole	2.3	0.2
BAC/No Azole	0.4	0.2

Table 1. Corrosion rates in milli-inches per year (mpy) from coupons placed in a cooling tower. Changing from chlorine dioxide to BAC decreased the corrosivity of the cooling water significantly.

Tower Parameter	Sodium Hypochlorite	BAC
	pH	7.6 ± 0.1
ORP, mV	550 ± 10	180 ± 70
Conductivity, µS	1900 ± 90	2300 ± 300
Unfiltered PO₄, ppm	13 ± 1	4 ± 1
Ca Hardness, ppm	400 ± 20	430 ± 60
TTA, ppm	2.7 ± 0.4	2.2 ± 0.9
Fe, ppm	0.2 ± 0.1	0.10 ± 0.04
Cu, ppm	0.09 ± 0.02	0.07 ± 0.02
MS Corr. Rate, mpy	0.4 ± 0.1	0.2 ± 0.1
Cu Corr. Rate, mpy	0.08 ± 0.02	0.00 ± 0.01
Bug Levels, cfu/mL	< 10 ³	< 10 ³

Table 2. Tower operating conditions and key performance indicators using two different treatment strategies at a chemical processing plant.

Parameter	Pre-XD3899	Post-XD3899
	Assessment Time	Jan - May
Fouling Factor	60 ± 40	30 ± 20
MS Corrosion, mpy	3 ± 2	3 ± 2
90:10 Cu:Ni Corrosion, mpy	0.2 ± 0.1	0.1 ± 0.1
System ORP, mV	380 ± 20	320 ± 30
System pH	8.1 ± 0.4	7.3 ± 0.1

Table 3. Tower operating conditions and key performance indicators using two different treatment strategies for a power plant cooling tower.



Research Cottrell Cooling, Inc.

For All Your Cooling Needs

58 East Main Street
Somerville, NJ 08876
www.rc-cooling.com

Research Cottrell Wet Cooling

Keith Silverman
908-333-2049
Keith.Silverman@rc-cooling.com

Jennifer Kellogg [spare parts](#)
908-333-2004
Jennifer.Kellogg@rc-cooling.com

Research Cottrell Dry Cooling

Neil Dahlberg
908-333-2022
Neil.Dahlberg@rc-cooling.com

With more than 100 years of experience in cooling tower technology, we specialize in custom solutions for the full spectrum of cooling tower applications in many industries, including power generation, petrochemical and chemical.



Our capabilities cover:

- New, design and supply of Air-Cooled Steam Condensers (ACC)
- New, turnkey design and construction of Mechanical and Natural Draft Cooling Towers
- Repairs, repacks, and upgrades to existing Mechanical and Natural Draft Cooling Towers
- Spare parts – including fan stacks, drift eliminators, fill media, distribution systems, and mechanical equipment

A subsidiary of Hamon Corporation



Attention Owner/Operators of Heat Transfer Systems*!

*(*Water Cooling Towers, Air Cooled Condensers, Evaporative Condensers and Fluid Air/Evaporative Coolers)*

Benefits of CTI Membership:

- Networking with industry peers/experts in all aspects of heat rejection equipment, including water treatment, mechanical equipment, structural design and testing/certification procedures.
- Exclusive access to the Owner/Operator Council which provides a forum to meet with other Owner/Operator's to discuss problems and issues related to your specific operation.
- The knowledge gained can help set priorities for solving specific problems. Industry standards and guidelines optimize the operation, maintenance of the equipment; maximizing value for the Owner/Operator.
- Two CTI meetings a year, an Annual Conference and Summer Committee Workshop. The Annual Conference includes the presentation of Technical Papers, Owner/Operator Seminar, Education Seminar, Committee Meetings and a Technical Exchange Exhibition.
- CTI Annual Conference provides a platform to publish and present technical papers.
- CTI offers an opportunity to all members to participate in developing standards and guidelines for their industry.

***Become a Member of the Cooling Technology Institute (CTI)
Visit www.CTI.org to Sign UP***



***At the Owner/Operator Council meeting an attendee told us:
"it helped solve a recurring problem which saved the company over \$100,000."***

Cooling Technology Institute Licensed Testing Agencies

For nearly thirty years, the Cooling Technology Institute has provided a truly independent, third party, thermal performance testing service to the cooling tower industry. In 1995, the CTI also began providing an independent, third party, drift performance testing service as well. Both these services are administered through the CTI Multi-Agency Tower Performance Test Program and provide comparisons of the actual operating performance of a specific tower installation to the design performance. By providing such information on a specific tower installation, the CTI Multi-Agency Testing Program stands in contrast to the CTI Cooling Tower Certification Program which certifies all models of a specific manufacturer's line of cooling towers perform in accordance with their published thermal ratings.



To be licensed as a CTI Cooling Tower Performance Test Agency, the agency must pass a rigorous screening process and demonstrate a high level of technical expertise. Additionally, it must have a sufficient number of test instruments, all meeting rigid requirements for accuracy and calibration.

Once licensed, the Test Agencies for both thermal and drift testing must operate in full compliance with the provisions of the CTI License Agreements and Testing Manuals which were developed by a panel of testing experts specifically for this program. Included in these requirements are strict guidelines regarding conflict of interest to insure CTI Tests are

conducted in a fair, unbiased manner.

Cooling tower owners and manufacturers are strongly encouraged to utilize the services of the licensed CTI Cooling Tower Performance Test Agencies. The currently licensed agencies are listed below.

Licensed CTI Thermal Testing Agencies

License Type*	Agency Name Address	Contact Person Website / Email	Telephone Fax
A,B	Clean Air Engineering 7936 Conner Rd Powell, TN 37849	Kenneth Hennon www.cleanair.com khennon@cleanair.com	800.208.6162 or 865.938.7555 (F) 865.938.7569
A, B	Cooling Tower Technologies Pty Ltd PO Box N157 Bexley North, NSW 2207 AUSTRALIA	Ronald Rayner coolingtwrtech@bigpond.com	61.2.9789.5900 (F) 61.2.9789.5922
A,B	Cooling Tower Test Associates, Inc. 15325 Melrose Dr. Stanley, KS 66221-9720	Thomas E. Weast www.cttai.com cttake@aol.com	913.681.0027 (F) 913.681.0039
A, B	McHale & Associates, Inc 4700 Coster Road Knoxville, TN 37912	Bernie Pastorik www.mchale.org bernie.pastorik@mchale.org	865.588.2654 (F) 865.934.4779

* Type A license is for the use of mercury in glass thermometers typically used for smaller towers.

Type B license is for the use of remote data acquisition devices which can accommodate multiple measurement locations required by larger towers.

Licensed CTI Drift Testing Agencies

Agency Name Address	Contact Person Website / Email	Telephone Fax
Clean Air Engineering 7936 Conner Rd Powell, TN 37849	Kenneth Hennon www.cleanair.com khennon@cleanair.com	800.208.6162 or 865.938.7569 (F) 865.938.7569
McHale & Associates, Inc. 4700 Coster Road Knoxville, TN 37912	Bernie Pastorik www.mchale.org bernie.pastorik@mchale.org	865.588.2654 (F) 865.934.4779



Cooling Towers Certified by CTI Under STD-201

As stated in its opening paragraph, CTI Standard STD-201 "...sets forth a program whereby the Cooling Technology Institute will certify that all models of a line of evaporative heat rejection equipment offered for sale by a specific Manufacturer will perform thermally in accordance with the Manufacturer's published ratings..."

By the purchase of a **CTI Certified** model, the Owner/Operator has assurance that the tower will perform as specified*.

*Performance as specified when the circulating water temperature is within acceptable limits and the air supply is ample and unobstructed. CTI Certification under STD-201 is limited to thermal operating conditions with entering wet bulb temperatures between 10°C and 32.2°C (50°F to 90°F), a maximum process fluid temperature of 51.7°C (125°F), a cooling range of 2.2°C (4°F) or greater, and a cooling approach of 2.8°C (5°F) or greater. The manufacturer may set more restrictive limits if desired or publish less restrictive limits if the CTI limits are clearly defined and noted in the publication.



For each certified line, all models have undergone a technical review for design consistency and rated performance. One or more representative models of each certified line have been thoroughly tested by a CTI Licensed testing agency for certification and found to perform as claimed by the Manufacturer.

The CTI STD-201 Thermal Performance Certification Program has grown rapidly since its' inception in 1983 (see graphs that follow). A total of 48 cooling tower manufacturers are currently active in the program. In addition, 8 of the manufacturers also market products as private brands through other companies.

While in competition with each other, these manufacturers benefit from knowing that they each achieve their published performance capability and distinguish themselves by providing the Owner/Operator's required thermal performance. The participating manufacturers currently have 119 certified product lines plus 14 product lines marketed as private brands which result in more than 26,600 CTI Certified cooling tower models to select from.

For a complete listing of certified product lines, and listings of all CTI Certified models, please see:

<http://www.cti.org/certification.shtml>

Those Manufacturers who have not yet chosen to certify their product lines are invited to do so at the earliest opportunity. Contact the CTI Administrator at vmanser@cti.org for more details.

Thermal Performance Certification Program Participation through December 31, 2015

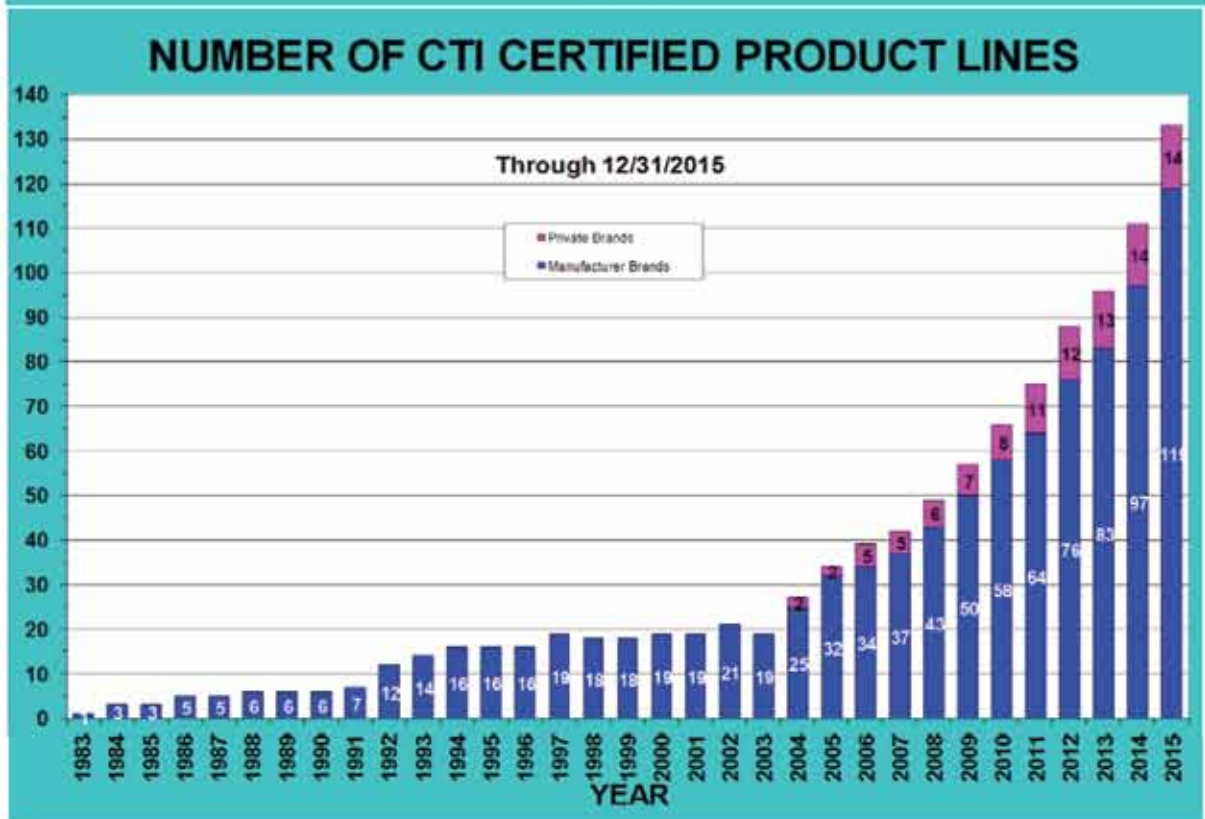
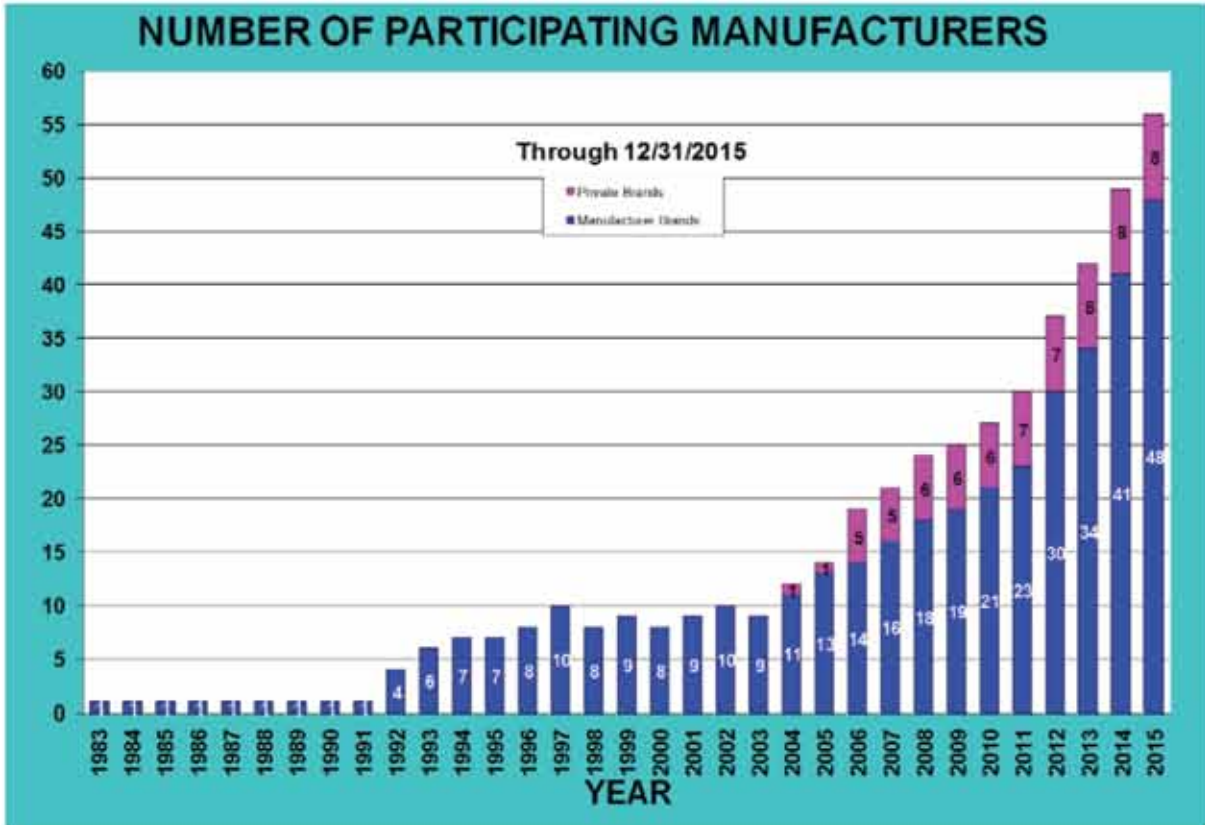

Current Program Participants

Program Participants and their certified product lines are listed below. Only the product lines listed here have achieved CTI STD-201 certification. For the most up-to-date information and a complete listing of all CTI Certified models please visit:

<http://www.cti.org/certification.shtml>

Current Certified Model Lists are available by clicking on the individual line names beneath the Participating Manufacturer name.

Catalog information and product selection data are also available by clicking on the links beneath each listed line.

A

Advance GRP Cooling Towers, Pvt.,Ltd.

Advance 2020 Series A Validation No. 07-31-01

Aggreko Cooling Tower Services

AG Line Validation No. C34A-08R02

Amcot Cooling Tower Corp.

Series R-LC Validation No. C11E-11R02

American Cooling Tower, Inc.

ACF Series Validation No. 10-38-01

ACX Series Validation No. 13-38-02

AONE E&C Corporation, Ltd.

ACT-C Line Validation No. C28B-09R01

ACT-R/ACT-RU Line Validation No. C28A-05R03

Axima (China) Energy Technology Co., Ltd.

EWX Line Validation No. C72A-15R00

ACC Line Validation No. C72B-15R00

B

Baltimore Aircoil Company, Inc.

ACT Line Validation No. 08-11-12

FXT Line Validation No. 92-11-01

FXV Line Validation No. C11J-98R10

PCT Line Validation No. C11N-10R01

PF Series Validation No. C11P-12R02

PT2 Series Validation No. C11L-07R03

Series V Closed VF1 & VFL Validation No. 00-11-10

Series V Open VT0,VT1,VTL & VTL-E

Validation No. C11B-92R06

Series 1500 Validation No. C11H-94R09

Series 3000 A,C,D,E & Compass

Validation No. C11F-92R17

Bell Cooling Tower Pvt, Ltd.

BCTI Line Validation No. C43A-12R02

C

Cool Water Technologies

RTAi Line Validation No. C52A-13R02

RTi Line Validation No. C52B-13R01

D

Delta Cooling Tower, Inc.

TM Series Validation No. 02-24-01

Decsa

RCC Series Validation No. C42C-14R00

DongGuan Shenling Cooling Equipment Co.,

Ltd

RT-L Series Validation No. C71A-15R00

RTM-L Series Validation No. C71B-15R00

E

Elendoo Technology (Beijing) Co., Ltd.

EL Line Validation No. C50C-15R00

ELH Line Validation No. C50A-13-R01

ELOP Line Validation No. C50B-14R01

E CONT

Evapco, Inc.

AT Series *Validation No. C13A-99R17*
ATWB Series *Validation No. 09-13-06*
ESWA & ESWB Series *Validation No. 05-13-05*
L Series Closed *Validation No. 09-13-07*
L Series Open *Validation No. 05-13-03*
PMTQ Line *Validation No. 10-13-09*
PMWQ Line *Validation No. 10-13-08*
AXS Line *Validation No. C13K-15R00*

G

GOHL (E.W.Gohl, GmbH)

DTC-ecoTec Line *Validation No. C92A-14R01*

Guangzhou Laxun Technology Exploit Company, Ltd.

HMK Line *Validation No. C45A-12R03*
LMB Line *Validation No. 12-45-02*
HMC Line *Validation No. C45C-15R00*
HMCC Line *Validation No. C45D-15R00*

H

Hon Ming (Guang Dong) Air Conditioning Equipment Company, Ltd.

MK Series *Validation No. C66A-15R00*

Hunan Yuanheng Technology Development Company, Ltd.

YHA Line *Validation No. C40A-11R03*
YHD Line *Validation No. C40B-15R00*

HVAC/R International, Inc.

Therflow Series TFC *Validation No. C28B-09R01*
Therflow Series TFW *Validation No. C28A-05R03*

I

Industrial Mexicana

Series 1000 *Validation No. C60A-15R00*
Series 6000 *Validation No. C60B-15R00*

J

Jacir

KS Line *Validation No. 12-46-01*
KSF Line *Validation No. C46B-15R00*

Jiangsu Dayang Cooling Tower Co., Ltd.

HLT Line *Validation No. C94A-14R00*

Ji'nan Chin-Tech Thermal Technology Co., Ltd.

CTN Line *Validation No. C91A-14R00*
CTH Line *Validation No. C91B-14R00*

K

Kelvion B.V. (formerly GEA Polacel)

Polacel CF Series *Validation No. 04-25-01*
Polacel XF Series *Validation No. 13-25-02*

KIMCO (Kyung In Machinery Company, Ltd.)

CKL Line *Validation No. C18B-05R03*
Eco-Dyna Cool Line *Validation No. C18C-09R01*
Endura Cool Line *Validation No. C18A-93R07*

King Sun Industry Company, Ltd.

HKB Line *Validation No. C35A-09R03*
HKD Line *Validation No. C35B-09R03*
KC Line *Validation No. C35-11R01*

L

Liang Chi Industry Company, Ltd.

Series C-LC *Validation No. C20B-09R02*
Series D-LC *Validation No. C20F-14R01*
Series R-LC *Validation No. C11E-11R02*
Series U-LC *Validation No. C20D-10R04*
Series V-LC *Validation No. C20C-10R01*

M

Marley (SPX Cooling Technologies)

Aquatower Series *Validation No. 01-14-05*
AV Series *Validation No. 98-14-04*
MCW Series *Validation No. 06-14-08*
MD Series *Validation No. 08-14-11*
MHF Series *Validation No. C14G-04R07*
NC Series *Validation No. C14A-92R18*
Quadraflow Line *Validation No. 92-14-02*
NX Series *Validation No. C14M-15R00*

Mesan Cooling Tower, Ltd.

MCC Series *Validation No. C26G-12R03*
MXC Series *Validation No. 12-26-08*
MXL Series *Validation No. C26F-12R02*
MXR-KM Series *Validation No. C26C-08R05*

Munters Corporation

Oasis PFC Line *Validation No. 12-48-01*

N

NIBA Su Sogutma Kulerleri San, ve Tic, A.S.

HMP-NB Line *Validation No. C55A-14R00*

Nihon Spindle Manufacturing Company, Ltd.

KG Line *Validation No. C33B-12R03*

O

OTT Company, Ltd.

OTTC Line *Validation No. 12-44-01*

OTTX Line *Validation No. 12-44-02*

OTTC-C Line *Validation No. C44C-14R00*

OTTX-C Line *Validation No. C44D-14R00*

P

Paharpur Cooling Tower, Ltd.

CF3 Line *Validation No. C51A-13R01*

OXF-30K Line *Validation No. C51B-14R00*

Proficool Fans Sp z.o.o.

BORA Line *Validation No. C90A-15R00*

Protec Cooling Towers, Inc.

FRS Series *Validation No. 05-27-03*

FWS Series *Validation No. 04-27-01*

R

Reymisa Cooling Towers, Inc. (Fabrica Mexicana de Torres, SA de CV)

HFC Line *Validation No. 10-22-06*

HRFG Line *Validation No. 04-22-03*

LSFG Line *Validation No. 09-22-04*

RT & RTM Series *Validation No. C22G-13R03*

SLSFG Line *Validation No. 09-22-05*

RSD Cooling Towers

RSS Series *Validation No. 08-32-01*

Ryowo (Holding) Company, Ltd.

FCS Series *Validation No. 10-27-04*

FDC Series *Validation No. 11-27-05*

FRS Series *Validation No. 05-27-03*

FVS Series *Validation No. 12-27-06*

FWS Series *Validation No. 04-27-01*

FXS Series *Validation No. 05-27-02*

S

Shanghai Baofeng Machinery Manufacturing Co., Ltd.

BTC Line *Validation No. 12-49-01*

Shanghai Liang Chi Cooling Equipment Co., Ltd.

LCM Line *Validation No. C62A-14R00*

Shanghai Tyacht Cooling System Co., Ltd.

TCT Line *Validation No. C93A-15R00*

TCC Line *Validation No. C93B-14R00*

Shanghai Wanxiang Cooling Equipment Company, Ltd.

FBH Line *Validation No. 13-54-01*

FKH/FKHL Series *Validation No. C94A-14R00*

Shangyu Dongjie Cooling Tower Co., Ltd.

DMNC Line *Validation No. C63A-15R00*

DHC Line *Validation No. C63B-15R00*

Sinro Air-Conditioning (Fogang) Company, Ltd.

CEF-A Line *Validation No. C37B-11R02*

SC-B Series *Validation No. C37C-11R02*

SC-H Series *Validation No. C37A-10R02*

T

Ta Shin F.R.P. Company, Ltd.

TSS Series *Validation No. 08-32-01*

The Cooling Tower Company, L.C

Series TCIA *Validation No. C29B-15R00*

Thermal-Cell sdn bhd

TYH Line *Validation No. C40A-11R03*

Tower Tech, Inc.

TTXL Line *Validation No. C17F-08R04*

TTXR Line *Validation No. C17F-15R00*

Truwater Cooling Towers, Inc.

EC-S Series *Validation No. 12-41-01*

EX-S Series *Validation No. 12-41-02*

VXS Series *Validation No. 13-41-03*

W

Wuxi Fangzhou Water Cooling Equipment Co., Ltd.

FKH Line *Validation C64A-14R00*

FNB Line *Validation C64B-15R00*

Y

Yantai Ebara Air Conditioning Equipment Company, Ltd.

CDW Line *Validation No. C53A-13R02*

CXW Line *Validation No. C53A-14R01*

York (By Johnson Controls)

AT Series *Validation No. C13A-99R17*

ESWA & ESWB Series *Validation No. 05-13-05*

LSTE Line *Validation No. 05-13-03*

Z

Zhejiang Jinling Refrigeration Engineering Company, Ltd.

JNC Series *Validation No. C28B-09R01*

JNT Series *Validation No. C28A-05R03*

Zhejiang Shangfeng Cooling Tower Co., Ltd.

SFB Line *Validation No. C73A-15R00*

Zhejiang Wanxiang Science and Technology Company, Ltd.

FBH Line *Validation No. 13-54-01*

For a complete listing of certified product lines, and listing of all CTI Certified models, please see:

<http://www.cti.org/certification.shtml>

**Always look for the CTI Certified Label
with Validation Number on Your Equipment**





CTI Toolkit Version 3.1

...now Windows 7 compatible

A great opportunity to upgrade your CTI Blue Book Version 1.0 and CTI Toolkit Version 2.0 Software

Key Features of CTI Toolkit Version 3.1:

- **Air Properties Calculator**; fully ASHRAE Compliant psychrometrics. Interactive.
- **Thermal Design Worksheet** in the "Demand Curve" Tab which can be saved to file and retrieved for later review. Now with printable and exportable graphs.
- **Performance Evaluator** in the "Performance Curve" Tab to evaluate induced draft or forced draft, crossflow or counterflow cooling tower performance. Now calculates percent performance or leaving water temperature deviation. Data can be entered manually or with an input file. Automatic Cross-Plotting. Now with printable and exportable graphs.
- **New and Improved Help Files** guide you through the software, explain performance evaluation techniques and offer tips for use.

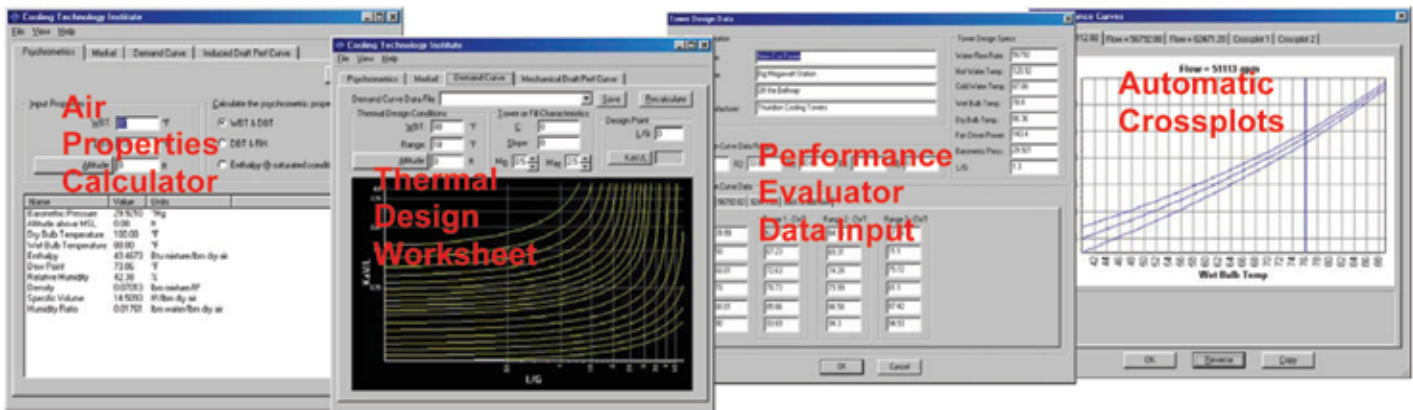

Now works with Microsoft Windows 7 and all earlier Windows Operating Systems back to Windows 95
16 MB ram recommended, and 3 MB free disk space required.

Upgrade Now! Only \$25/per upgrade from 3.0 for CTI Members (\$40 for Non-Members)

To Order, Call (281) 583-4087 or visit CTI's Website www.cti.org

8/8/08



Order Today
Call 281-583-4087

"The Performance Curve method is widely recognized as a more accurate method of determining tower capability from measured test data. The new CTI ToolKit Tab Application provides a quick and easy method for anyone to evaluate a performance test using this more accurate method."

- Rich Harrison, Jr. ATC-105 Task Group Chairman

Bill to: _____

Phone: _____ **Fax:** _____

Email Address: _____

Ship to: _____

Phone: _____ **Fax:** _____

Email Address: _____

Charges can be made to Visa, MasterCard or American Express

Card No.: _____ **Expiration Date:** _____

Signature: _____ **CVV; CVC; CID Code:** _____

Product	Unit Price	Quantity	Total
CTI ToolKit Version 3.1 (single user license)			
CTI Member	\$395		
Non-member	\$450		
CTI ToolKit Version 3.1 (Upgrade from V1.0 and V2.0)			
CTI Member	\$ 95		
Non-member	\$120		
CTI ToolKit Version 3.1 (Upgrade from V3.0)			
CTI Member	\$ 25		
Non-member	\$ 40		
PerfCurv 3.1 (Stand alone Performance Curve application)			
CTI Member	\$195		
Non-member	\$240		
Shipping for CD-Rom (from Texas): <small>Priority mail \$6; 2nd Day Air \$18; Overnight Domestic \$28; / International (DHL) TBA</small>			

System Requirements:
 Microsoft Windows®
 95/98, 2000, XP, and
 Windows 7



Phone: 281.583.4087
 Fax: 281.537.1721
 Web: <http://www.cti.org>

Multi-user site licenses and educational institution pricing available on request



Index of Advertisers

Aggreko Cooling Tower Services	46-47
AHR Expo	75
Amarillo Gear Company	IBC
American Cooling Tower, Inc.	31
AMSA, Inc.	41
Bailsco Blades & Castings, Inc.	4
Baldor	35
Baltimore Aircoil Company	OBC
Bedford Reinforced Plastics	63
Brentwood Industries	51
ChemTreat, Inc.	9
CTI Certified Towers	84-89
CTI License Testing Agencies	83
CTI Owner/Operators	82
CTI ToolKit	90-91
Cooling Tower Resources	25
Denso	59
Gaiennie Lumber Company	48
Glocon	3
Hewitech	28
Hudson Products Corporation	5, 53
IMI Sensors	15
Industrial Cooling Towers	IFC, 2
Kipcon	19
KIMCO	57
Midwest Cooling Towers	67
Moore Fans	55
North Street Cooling Towers	43
Qualichem	61
Research Cottrell Cooling	81
Rexnord Industries	33
C.E. Shepherd Company, LP	21
Simpson Strong-Tie	37
Spraying Services, Inc.	29
SPX Cooling Technologies	69
Strongwell	11
Tower Performance of Texas	39
Tower Performance, Inc.	92
Turbo Machinery	71
Walchem (Iwaki America)	65

TPI Tower Performance, Inc. Cooling Tower Specialists

Since 1964, Tower Performance, Inc., has been providing full service to the utility, cogeneration, chemical, petrochemical, and related industries by constructing new cooling towers and upgrading and repairing all makes and models of existing cooling towers.



New Cooling Towers:

- Counterflow • Crossflow
- Wood • FRP

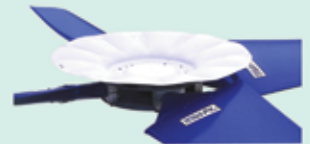

Professional Services Include:

- Cooling Tower Evaluations
- Bid Preparations • Wood Analysis
- Thermal Engineering

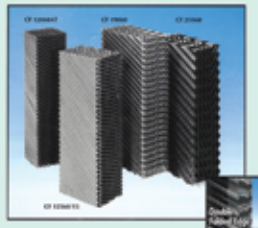

Field Services Include:

- Repair & Overhaul
- Scheduled Maintenance
- Inspection & Evaluations
- Emergency Service



Nationwide Service

New Jersey Office:

Toll Free: (800) 631-1196
 NJ: (973) 966-1116
 NY: (212) 355-0746
 Fax: (973) 966-5122

E-Mail: stefanguetzov@towerperformance.com

Arkansas Office:

Ph: (504) 236-3629
 Fax: (870) 862-2810
 E-Mail: ctowers@tpila.com

Pennsylvania Office:

Ph: (215) 778-6027
 Fax: (215) 938-8900
 E-Mail: smorris@towerperformance.com

Parts Sales:

Toll Free: (800) 314-1695
 Ph: (970) 593-8637
 Fax: (970) 472-1304

E-Mail: jfritz@towerperformance.com



Texas Office:

Toll Free: (800) 324-0691
 Ph: (713) 643-0691
 Fax: (713) 643-0310

E-Mail: ctowers@tpitx.com



OVER 95 YEARS QUALITY BUILT HERE

AMARILLO[®]

Gear Company has built a worldwide reputation for building quality gear drives and composite drive shaft assemblies during its 95 year history. While others farm-out and piecemeal, Amarillo still designs and manufactures its gears and builds them in Amarillo, Texas.

Amarillo is ISO 9001:2008 quality certified and stands behind their extensive line of right angle spiral bevel cooling tower fan drives, including single and double reduction models.

They also 100% manufacture the high quality A Series drives for drop-in replacement of other manufacturer's models, complete with the backing of Amarillo's warranty.



Tested. Proven. Amarillo.[®]

Want to know more? Please contact our staff of sales representatives or gear engineers for a quick response to your fan drive needs.

www.amarillogear.com (806) 622-1273
info@amarillogear.com

**Amarillo[™]
Gear
Company LLC**



A Marmon Water/Berkshire Hathaway Company



Leading INNOVATION Forward

AWARD-WINNING SOLUTIONS



Series 3000 COOLING TOWER

WITH
**ENDURA
DRIVE™**
Fan System

Pfi CLOSED CIRCUIT COOLING TOWER

WITH
**Opti
Coil™**
SYSTEM

*The Only Variable Speed Direct Drive
Solution for Modular Cooling Towers*

10% energy savings

90% reduction in maintenance costs

Highest reliability
on the transmission system



*Combines Indirect and Direct Heat
Transfer for Maximum Performance*

30%+ increase in capacity*

Lowest total cost of ownership*

Flexibility for dry operation applications

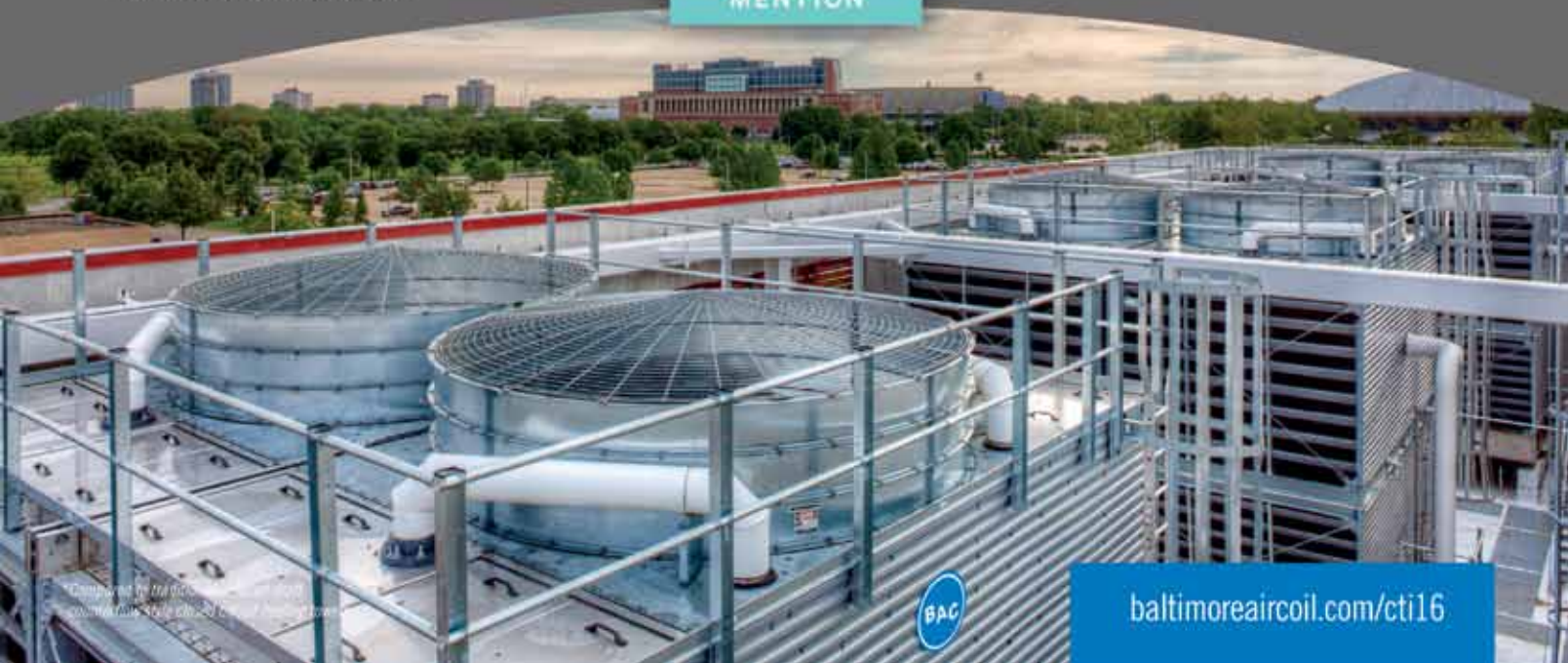

baltimoreaircoil.com/cti16